



**THE DATASHEET OF  
TAS2555YZT**



## TAS2555 5.7-W Class-D mono audio amplifier with class-H boost and speaker sense

### 1 Features

- Ultra low-noise mono boosted class-D amplifier
  - 5.7 W at 1% THD+N and 6.9 W at 10% THD+N into 4-Ω load from 4.2-V supply
  - 3.8 W at 1% THD+N and 4.5 W at 10% THD+N into 8-Ω load from 4.2-V supply
- Output noise for DAC + class-D (ICN) is 15.9 μV
- DAC + class-D SNR 111 dB at 1%THD+N/8 Ω
- THD+N – dB at 1 W / 8 Ω with flat frequency response
- PSRR dB for 200 mV<sub>pp</sub> ripple at 217 Hz
- Input sample rates from 8 kHz to 96 kHz
- Built-in speaker sense
  - Measures speaker current and voltage
  - Measures V<sub>BAT</sub> voltage, chip temperature
- Dedicated real-time DSP for speaker protection
  - Thermal and excursion protection
  - Detects speaker leaks and damage
- High efficiency class-H boost converter with multi-level tracking
  - 86% at 500 mW in 8 Ω with 3.6 V V<sub>BAT</sub>
  - 87% at 700 mW in 8 Ω with 4.2 V V<sub>BAT</sub>
- Configurable automatic gain control (AGC)
  - Limits battery current consumption
- Adjustable class-D switching edge-rate control
- Thermal, short-circuit, and under-voltage protection
- I<sup>2</sup>S, Left-justified, right-justified, DSP, and TDM input and output interface,
- I<sup>2</sup>C or SPI interface for register control
- Stereo configuration using two TAS2555 devices
- Power supplies
  - Boost input: 2.9 V to 5.5 V
  - Analog/digital: 1.65 V to 1.95 V
  - Digital I/O: 1.62 V to 3.6 V
- 42-ball, 0.5-mm pitch, DSBGA package

### 2 Applications

- Mobile phones and tablets
- Video doorbells and voice enabled thermostats
- Personal computers
- Bluetooth speakers and accessories

### 3 Description

The TAS2555 device is a state-of-the-art Class-D audio amplifier which is a full system on a Chip (SoC). The device features a ultra low-noise audio DAC and Class-D power amplifier which incorporates speaker voltage and current sensing feedback. An on-chip, low-latency DSP supports Texas Instruments SmartAmp speaker protection algorithms to maximizes loudness while maintaining safe speaker conditions.

The device can be used easily with any processor with an I2S output and stereo implementations are possible when using two TAS2555 devices. Separate tuning for different speakers is supported allowing customers to add value while maintaining form factor designs. Additionally, the TAS2555 supports separate voice and audio tuning dynamically with ultra-low 15.9 μV ICN regardless of mode of operation making receiver/speaker implementations possible.

A Class-H boost converter generates the Class-D amplifier supply rail. When the audio signal only requires a lower Class-D output power, the boost improves system efficiency by deactivating and connecting V<sub>BAT</sub> directly to the Class-D amplifier supply. When higher audio output power is required, the multi-level boost quickly activates tracking the signal to provide the additional voltage to the load.

#### Device Information<sup>(1)</sup>

PART NUMBER	PACKAGE	BODY SIZE (NOM)
TAS2555	DSBGA (42)	3.47 mm × 3.23 mm

(1) For all available packages, see the orderable addendum at the end of the data sheet.

#### Simplified Schematic

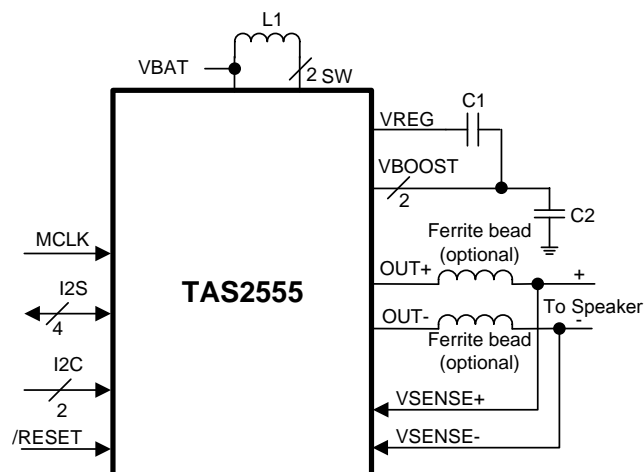

## Table of Contents

<b>1 Features</b> .....	<b>1</b>	9.5 Programming.....	<b>30</b>
<b>2 Applications</b> .....	<b>1</b>	<b>10 Application and Implementation</b> .....	<b>33</b>
<b>3 Description</b> .....	<b>1</b>	10.1 Application Information.....	<b>33</b>
<b>4 Revision History</b> .....	<b>2</b>	10.2 Typical Applications .....	<b>33</b>
<b>5 Device Comparison Table</b> .....	<b>3</b>	10.3 Initialization Set Up .....	<b>35</b>
<b>6 Pin Configuration and Functions</b> .....	<b>4</b>	<b>11 Power Supply Recommendations</b> .....	<b>36</b>
<b>7 Specifications</b> .....	<b>6</b>	11.1 Power Supplies .....	<b>36</b>
7.1 Absolute Maximum Ratings .....	<b>6</b>	11.2 Power Supply Sequencing.....	<b>36</b>
7.2 ESD Ratings.....	<b>6</b>	<b>12 Layout</b> .....	<b>37</b>
7.3 Recommended Operating Conditions.....	<b>6</b>	12.1 Layout Guidelines .....	<b>37</b>
7.4 Thermal Information .....	<b>6</b>	12.2 Layout Example .....	<b>38</b>
7.5 Electrical Characteristics.....	<b>7</b>	<b>13 Register Map</b> .....	<b>39</b>
7.6 I <sup>2</sup> C Timing Requirements .....	<b>9</b>	13.1 Register Map Summary .....	<b>39</b>
7.7 SPI Timing Requirements .....	<b>9</b>	13.2 Book 0 Page 0 .....	<b>42</b>
7.8 I <sup>2</sup> S/LJF/RJF Timing in Master Mode .....	<b>10</b>	13.3 Book 0 Page 1 .....	<b>48</b>
7.9 I <sup>2</sup> S/LJF/RJF Timing in Slave Mode .....	<b>10</b>	13.4 Book 0 Page 2 .....	<b>74</b>
7.10 DSP Timing in Master Mode .....	<b>10</b>	13.5 Book 100 Page 0 .....	<b>76</b>
7.11 DSP Timing in Slave Mode .....	<b>11</b>	<b>14 Device and Documentation Support</b> .....	<b>84</b>
7.12 Typical Characteristics .....	<b>14</b>	14.1 Documentation Support .....	<b>84</b>
<b>8 Parameter Measurement Information</b> .....	<b>16</b>	14.2 Community Resources.....	<b>84</b>
<b>9 Detailed Description</b> .....	<b>17</b>	14.3 Trademarks .....	<b>84</b>
9.1 Overview .....	<b>17</b>	14.4 Electrostatic Discharge Caution.....	<b>84</b>
9.2 Functional Block Diagram .....	<b>18</b>	14.5 Glossary .....	<b>84</b>
9.3 Feature Description.....	<b>18</b>	<b>15 Mechanical, Packaging, and Orderable Information</b> .....	<b>84</b>
9.4 Device Functional Modes.....	<b>24</b>	15.1 Package Dimensions .....	<b>84</b>

## 4 Revision History

NOTE: Page numbers for previous revisions may differ from page numbers in the current version.

<b>Changes from Revision A (November 2016) to Revision B</b>	<b>Page</b>
• Added Boost, Switching, Regulator voltage and Note 2 to the <i>Absolute Maximum Ratings</i> table .....	<b>6</b>
• Changed C2 Capacitance at 8.5 V derating MIN value From: 7 $\mu$ F To: 3.3 $\mu$ F in <a href="#">Table 4</a> .....	<b>34</b>

<b>Changes from Original (August 2015) to Revision A</b>	<b>Page</b>
• Changed device from Custom to Catalog .....	<b>1</b>

## 5 Device Comparison Table

PART NUMBER	CONTROL METHOD	Boost Voltage	SNR <sup>(1)</sup>	ICN	THD+N	Boost Control	SmartAmp Digital Engine
TAS2552	I <sup>2</sup> C	8.5 V	94 dB	130 $\mu$ V	-64 dB	Class-G	NO (External Processing Required)
TAS2553	I <sup>2</sup> C	7.5 V	94 dB	130 $\mu$ V	-64 dB	Class-G	NO (External Processing Required)
TAS2555	I <sup>2</sup> C or SPI	8.5 V	111 dB	15.9 $\mu$ V	-90 dB	Class-H	YES (Processing on Chip)
TAS2557	I <sup>2</sup> C or SPI	8.5 V	111 dB	15.9 $\mu$ V	-90 dB	Class-H	YES (Processing on Chip)
TAS2560	I <sup>2</sup> C	8.5 V	111 dB	16.2 $\mu$ V	-88 dB	Class-H	NO (External Processing Required)
TAS2559	I <sup>2</sup> C or SPI	8.5 V	111 dB	15.9 $\mu$ V	-90 dB	Class-H	YES (Processing on Chip)

(1) A weighted data.

## 6 Pin Configuration and Functions

**42-Ball DSBGA  
YF Package  
(Top View)**

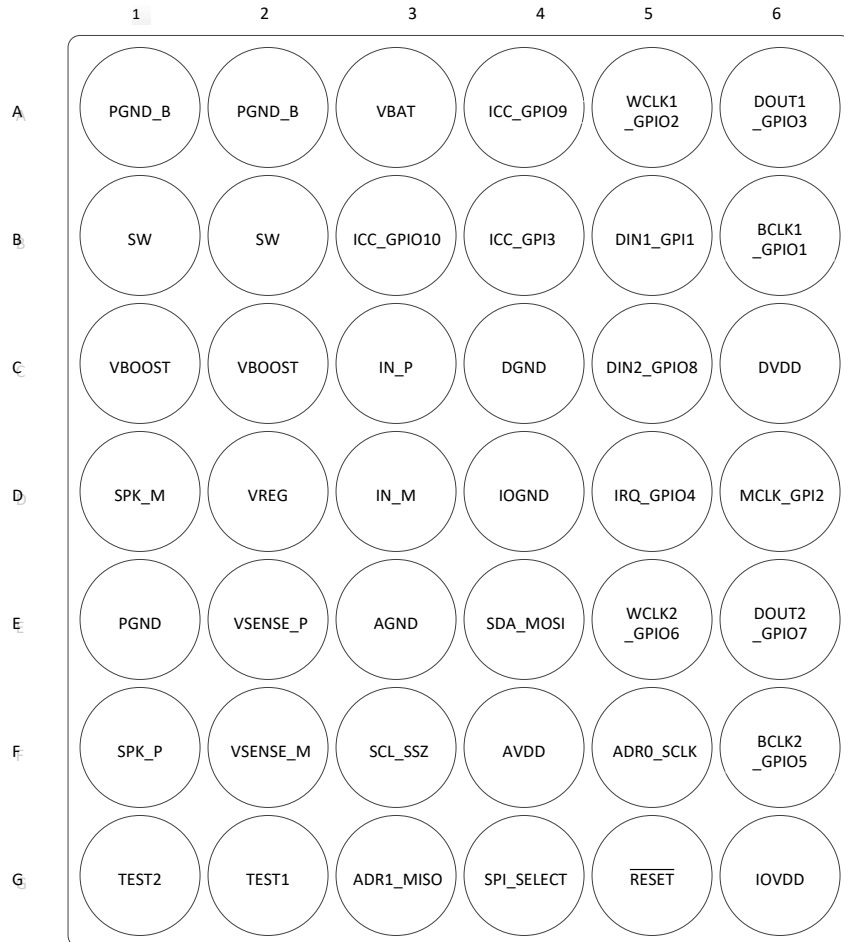

Not to scale

### Pin Functions

PIN		I/O/POWER	DESCRIPTION
NO.	NAME		
A1,A2	PGND_B	P	Power ground. Connect to high current ground plane.
A3	VBAT	P	Battery power supply. Connect to 2.9 V to 5.5 V battery supply.
A4	ICC_GPIO9	I/O	Stereo serial Port Interface Clock or GPIO pin.
A5	WCLK1_GPIO2	I/O	Word Clock on ASI#1 or GPIO pin.
A6	DOUT1_GPIO3	I/O	Data Output on ASI#1 or GPIO pin.
B1,B2	SW	P	Boost Converter Switch Input
B3	ICC_GPIO10	I/O	Stereo serial Port Interface Data Output or GPIO pin.
B4	ICC_GPI3	I	Stereo serial Port Interface Data Input or GPI pin
B5	DIN1_GPI1	I	Audio Data Input to ASI #1 or GPI pin.
B6	BCLK1_GPIO1	I/O	Serial Bit Clock on ASI#1 or GPIO pin.
C1,C2	VBOOST	P	Boost Converter Output
C3	IN_P	I	Non-inverting analog input. Ground pin if not used.
C4	DGND	P	Digital Ground Pin.
C5	DIN2_GPIO8	I/O	Audio Data Input to ASI #2 or GPIO pin.
C6	DVDD	P	1.8V Digital Power Supply for digital core logic.

**Pin Functions (continued)**

PIN		I/O/POWER	DESCRIPTION
NO.	NAME		
D1	SPK_M	O	Inverting Class D Output
D2	VREG	P	Regulator Output
D3	IN_M	I	Inverting analog input. Ground pin if not used
D4	IOGND	P	Digital Interface Ground Pin.
D5	IRQ_GPIO4	I/O	Active-High interrupt pin or GPIO pin
D6	MCLK_GPIO2	I	Master Clock Input or GPI pin.
E1	PGND	P	Power ground. Connect to high current ground plane.
E2	VSENSE_P	I	Non-inverting voltage sense Input
E3	AGND	P	Analog ground. Connect to low noise ground plane.
E4	SDA_MOSI	I/O	Multi Function Digital Pin For (SPI_SELECT= 0) : Data Pin for I <sup>2</sup> C Control bus For (SPI_SELECT= 1): SPI Data Input
E5	WCLK2_GPIO6	I/O	Word Clock on ASI#2 or GPIO pin.
E6	DOUT2_GPIO7	I/O	Data Output on ASI#2 or GPIO pin.
F1	SPK_P	O	Non-inverting Class D Output
F2	VSENSE_M	I	Inverting voltage sense Input
F3	SCL_SSZ	I	Multi Function Digital Input For (SPI_SELECT= 0) : Clock Pin for I <sup>2</sup> C Control bus For (SPI_SELECT= 1): SPI chip selection pin
F4	AVDD	P	1.8V Analog Power Supply
F5	ADR0_SCLK	I	Multi Function Digital Pin For (SPI_SELECT= 0) : Device I <sup>2</sup> C Programming Address LSB. For (SPI_SELECT= 1): SPI Serial Bit Clock
F6	BCLK2_GPIO5	I/O	Serial Bit Clock on ASI#2 or GPIO pin.
G1	TEST2	-	Float Connection - Do not route any signal or supply to or through this pin.
G2	TEST1	-	Float Connection - Do not route any signal or supply to or through this pin.
G3	ADR1_MISO	I/O	Multi Function Digital Input / Output For (SPI_SELECT= 0) : Device I <sup>2</sup> C Programming Address MSB For (SPI_SELECT= 1): SPI Data Output
G4	SPI_SELECT	I	Control Interface Select 0: I <sup>2</sup> C Selected 1: SPI Selected
G5	RESET	I	Active Low Reset.
G6	IOVDD	P	1.8V or 3.3V Digital interface Power Supply for digital input and output levels.

## 7 Specifications

### 7.1 Absolute Maximum Ratings

over operating free-air temperature range,  $T_A = 25^\circ\text{C}$  (unless otherwise noted)<sup>(1)</sup>

		MIN	MAX	UNIT
Battery voltage	VBAT	-0.3	6	V
Analog supply voltage	AVDD	-0.3	2	V
Digital supply voltage	DVDD	-0.3	2	V
I/O Supply voltage	IOVDD	-0.3	3.9	V
Analog input voltage	IN_M, IN_P	-0.3	AVDD	V
Boost	VBST	-0.3	9.2	V
Switching	SW	-0.7	VBST + 1.5 <sup>(2)</sup>	V
Regulator voltage	VREG	-0.3	VBST + 5	V
Digital input voltage		-0.3	IOVDD + 0.3	V
Output continuous total power dissipation		See <a href="#">Thermal Information</a>		NA
Storage temperature, $T_{\text{stg}}$		-65	150	$^\circ\text{C}$

- (1) Stresses beyond those listed under “Absolute Maximum Ratings” may cause permanent damage to the device. These are stress ratings only, and functional operation of the device at these or any other conditions beyond those indicated under [Recommended Operating Procedures](#) is not implied. Exposure to absolute–maximum–rated conditions for extended periods may affect device reliability.
- (2) Cannot exceed 11 V for greater than 10 nS or 10 V continuously.

### 7.2 ESD Ratings

		VALUE	UNIT
$V_{\text{(ESD)}}$ Electrostatic discharge	Human-body model (HBM), per ANSI/ESDA/JEDEC JS-001 <sup>(1)</sup>	$\pm 2500$	V
	Charged-device model (CDM), per JEDEC specification JESD22-C101 <sup>(2)</sup>	$\pm 1500$	

- (1) JEDEC document JEP155 states that 500-V HBM allows safe manufacturing with a standard ESD control process.
- (2) JEDEC document JEP157 states that 250-V CDM allows safe manufacturing with a standard ESD control process.

### 7.3 Recommended Operating Conditions

over operating free-air temperature range (unless otherwise noted)

		MIN	NOM	MAX	UNIT
Battery voltage	VBAT	2.9 <sup>(1)</sup>	3.6	5.5	V
Analog supply voltage	AVDD	1.65	1.8	1.95	V
Digital supply voltage	DVDD	1.65	1.8	1.95	V
I/O supply voltage 1.8 V	IOVDD	1.62	1.8	1.98	V
I/O supply voltage 3.3 V	IOVDD	3.0	3.3	3.6	V
$T_A$ Operating free-air temperature		-40		85	$^\circ\text{C}$
$T_J$ Operating junction temperature		-40		150	$^\circ\text{C}$

- (1) Device is functional down to 2.7V. See [Battery Tracking AGC](#)

### 7.4 Thermal Information

THERMAL METRIC <sup>(1)</sup>		TAS2555	UNIT
		42 PINS	
$R_{\text{thJA}}$	Junction-to-ambient thermal resistance	49.8	$^\circ\text{C/W}$
$R_{\text{thJC(top)}}$	Junction-to-case (top) thermal resistance	0.2	
$R_{\text{thJB}}$	Junction-to-board thermal resistance	7.1	
$\psi_{\text{JT}}$	Junction-to-top characterization parameter	0.8	
$\psi_{\text{JB}}$	Junction-to-board characterization parameter	7.1	
$R_{\text{thJC(bot)}}$	Junction-to-case (bottom) thermal resistance	n/a	

- (1) For more information about traditional and new thermal metrics, see the [Semiconductor and IC Package Thermal Metrics](#) application report.

## 7.5 Electrical Characteristics

$V_{BAT} = 3.6V$ ,  $AVDD = DVDD = IOVDD = 1.8V$ ,  $\overline{RESET} = IOVDD$ , Gain = 16.4 dB, ERC = 14ns, Boost Inductor = 2.2  $\mu H$ ,  $R_L = 8\ \Omega + 33\ \mu H$ , 1-kHz input frequency, 48- kHz sample rate for digital input, Class-H Boost Enabled,  $T_A = 25^\circ C$ , ILIM = 3 A (unless otherwise noted)

PARAMETER	TEST CONDITIONS	MIN	TYP	MAX	UNIT
<b>BOOST CONVERTER</b>					
Boost Output Voltage	Average voltage (w/o including ripple).		8.5		V
Boost Converter Switching Frequency			1.77		MHz
Boost Converter Current Limit			3		A
Boost Converter Max In-Rush Current	High Efficiency Mode: Max inductor inrush and startup current after enable		4		A
	Normal Efficiency Mode: Max inductor inrush and startup current after enable		1.5		
<b>CLASS-D CHANNEL</b>					
Output Voltage for Full-Scale Digital Input			6.6		$V_{RMS}$
Load Resistance (Load Spec Resistance)		3.6	8		$\Omega$
Class-D Frequency	Avg Frequency in Spread-Spectrum Mode		384		kHz
	Fixed Frequency	44.1 $\times$ 8	48 $\times$ 8		
Class-D + Boost Efficiency	$P_{OUT} = 3.5\ W$ (sinewave) ROM Mode 1		80		%
	$P_{OUT} = 0.5\ W$ (sinewave) ROM Mode 1		87		
Class-D Output Current Limit (Short Circuit Protection)	VBOOST = 8.5 V, OUT– shorted to VBAT, VBOOST, GND		6		A
Class-D Output Offset Voltage in Digital Input Mode		-2.5		2.5	mV
Programmable Channel Gain Accuracy			$\pm 0.5$		dB
Mute Attenuation	Device in shutdown or device in normal operation and MUTED		150		dB
VBAT Power Supply Rejection Ratio (PSRR)	Ripple of 200 mVpp at 217 Hz		110		dB
AVDD Power Supply Rejection Ratio (PSRR)	Ripple of 200 mVpp at 217 Hz		99		dB
THD+N	1 kHz, $P_{OUT} = 0.1\ W$		0.0041		%
	1 kHz, $P_o = 0.5\ W$		0.0036		
	1 kHz, $P_o = 1\ W$		0.0035		
	1 kHz, $P_o = 3\ W$		0.02		
Output Integrated Noise (20 Hz-20 kHz) - 8 $\Omega$	A-wt Filter, DAC modulator switching		15.9		$\mu V$
Signal-to-noise ratio	Referenced to 1% THD+N at output, a-weighted		110.6		dB
Max Output Power, 3-A Current Limit	THD+N=1%, 8- $\Omega$ Load		3.7		W
	THD+N=1%, 6- $\Omega$ Load		4.5		
	THD+N=1%, 4- $\Omega$ Load		5		
Startup Pop	Digital Input, A-weighted output		10		mV
Output Impedance in Shutdown	/RESET = 0 V		10		k $\Omega$
Startup Time	Time taken from end of configuring device in ROM mode1/2 to Speaker output signal in SPI mode running at 25 MHz with 48 ksp/s input		8		mS
Shutdown Time	Measured from time when device is programmed in software shutdown mode		100		$\mu S$

**Electrical Characteristics (continued)**

$V_{BAT} = 3.6V$ ,  $AVDD = DVDD = IOVDD = 1.8V$ ,  $\overline{RESET} = IOVDD$ , Gain = 16.4 dB, ERC = 14ns, Boost Inductor = 2.2  $\mu H$ ,  $R_L = 8\ \Omega + 33\ \mu H$ , 1-kHz input frequency, 48- kHz sample rate for digital input, Class-H Boost Enabled,  $T_A = 25^\circ C$ , ILIM = 3 A (unless otherwise noted)

PARAMETER		TEST CONDITIONS	MIN	TYP	MAX	UNIT
<b>CURRENT SENSE</b>						
Current Sense Full Scale	Peak current which will give full scale digital output 8- $\Omega$ load		1.25		$A_{PEAK}$	
	Peak current which will give full scale digital output 6- $\Omega$ load		1.48			
	Peak current which will give full scale digital output 4- $\Omega$ load		1.76			
Current Sense Accuracy	$I_{OUT} = 354\ mA_{RMS}$ (1 W)		1			%
<b>VOLTAGE SENSE</b>						
Voltage Sense Full Scale	Peak voltage which will give full scale digital output		8.5			$V_{PEAK}$
Voltage Sense Accuracy	$V_{OUT} = 2.83\ V_{rms}$ (1 W)		1			%
<b>INTERFACE</b>						
Voltage and Current Sense Data Rate	TDM/I2S		48			kHz
Voltage and Current Sense ADC OSR	TDM/I2S		64			OSR
$F_{MCLK}$	MCLK frequency		0.512		49.15	MHz
<b>POWER CONSUMPTION</b>						
Power Consumption with Digital Input and Speaker Protection Disabled (ROM MODE 1)	From VBAT, PLL off, no signal		3			mA
	From AVDD, PLL off, no signal		1.7			mA
	From DVDD, PLL off, no signal		3.9			mA
Power Consumption with Digital Input and Speaker Protection Enabled	From VBAT, PLL on, no signal		3			mA
	From AVDD, PLL on, no signal		3.4			mA
	From DVDD, PLL on, no signal		20			mA
Power Consumption in Hardware Shutdown	From VBAT, /RESET = 0		0.1			$\mu A$
	From AVDD, /RESET = 0		0.2			$\mu A$
	From DVDD, /RESET = 0		1			$\mu A$
Power Consumption in Software Shutdown See <a href="#">Low Power Sleep Mode</a>	From VBAT		0.1			$\mu A$
	From AVDD		0.1			$\mu A$
	From DVDD		9.7			$\mu A$
<b>DIGITAL INPUT / OUTPUT</b>						
$V_{IH}$	High-level digital input voltage	All digital pins except SDA and SCL, IOVDD = 1.8-V operation	0.65 $\times$ IOVDD			V
$V_{IL}$	Low-level digital input voltage		0.35 $\times$ IOVDD			V
$V_{IH}$	High-level digital input voltage	All digital pins except SDA and SCL, IOVDD = 3.3-V operation	2			V
$V_{IL}$	Low-level digital input voltage		0.45			V
$V_{OH}$	High-level digital output voltage	All digital pins except SDA and SCL, IOVDD = 1.8-V operation For $I_{OL} = 2\ mA$ and $I_{OH} = -2\ mA$	IOVDD – 0.45			V
$V_{OL}$	Low-level digital output voltage		0.45			V
$V_{OH}$	High-level digital output voltage	All digital pins except SDA and SCL, IOVDD = 3.3-V operation For $I_{OL} = 2\ mA$ and $I_{OH} = -2\ mA$	2.4			V
$V_{OL}$	Low-level digital output voltage		0.4			V
$I_{IH}$	High-level digital input leakage current	Input = IOVDD	-5	0.1	5	$\mu A$
$I_{IL}$	Low-level digital input leakage current	Input = Ground	-5	0.1	5	$\mu A$
<b>MISCELLANEOUS</b>						
$T_{TRIP}$	Thermal Trip Point		140			$^\circ C$

## 7.6 I<sup>2</sup>C Timing Requirements

For I<sup>2</sup>C interface signals over recommended operating conditions (unless otherwise noted). **Note:** All timing specifications are specified by design but not tested at final test. See [Figure 1](#)

PARAMETER	TEST CONDITION	Standard-Mode			Fast-Mode			UNITS
		MIN	TYP	MAX	MIN	TYP	MAX	
f <sub>SCL</sub>	SCL clock frequency	0		100	0		400	kHz
t <sub>HD,STA</sub>	Hold time (repeated) START condition. After this period, the first clock pulse is generated.	4			0.6			μs
t <sub>LOW</sub>	LOW period of the SCL clock	4.7			1.3			μs
t <sub>HIGH</sub>	HIGH period of the SCL clock	4			0.6			μs
t <sub>SU,STA</sub>	Setup time for a repeated START condition	4.7			0.6			μs
t <sub>HD,DAT</sub>	Data hold time: For I <sup>2</sup> C bus devices	0		3.45	0		0.9	μs
t <sub>SU,DAT</sub>	Data set-up time	250			100			ns
t <sub>r</sub>	SDA and SCL Rise Time			1000	20 + 0.1 × C <sub>b</sub>		300	ns
t <sub>f</sub>	SDA and SCL Fall Time			300	20 + 0.1 × C <sub>b</sub>		300	ns
t <sub>SU,STO</sub>	Set-up time for STOP condition	4			0.6			μs
t <sub>BUF</sub>	Bus free time between a STOP and START condition	4.7			1.3			μs
C <sub>b</sub>	Capacitive load for each bus line			400			400	pF

## 7.7 SPI Timing Requirements

For SPI interface signals over recommended operating conditions (unless otherwise noted). **Note:** All timing specifications are specified by design but not tested at final test. See [Figure 2](#)

PARAMETER	TEST CONDITION	IOVDD = 1.8 V			IOVDD = 3.3 V			UNITS
		MIN	TYP	MAX	MIN	TYP	MAX	
t <sub>sck</sub>	SCLK Period	40			30			ns
t <sub>sckh</sub>	SCLK Pulse width High	40			30			ns
t <sub>sckl</sub>	SCLK Pulse width Low	40			30			ns
t <sub>lead</sub>	Enable Lead Time	40			30			ns
t <sub>trail</sub>	Enable Trail Time	40			30			ns
t <sub>d,seqxfr</sub>	Sequential Transfer Delay	40			30			ns
t <sub>a</sub>	Slave DOUT access time			35			25	ns
t <sub>dis</sub>	Slave DOUT disable time			35			25	ns
t <sub>su</sub>	DIN data setup time	8			8			ns
t <sub>h,DIN</sub>	DIN data hold time	8			8			ns
t <sub>v,DOUT</sub>	DOUT data valid time			35			25	ns
t <sub>r</sub>	SCLK Rise Time			4			4	ns
t <sub>f</sub>	SCLK Fall Time			4			4	ns

## 7.8 I<sup>2</sup>S/LJF/RJF Timing in Master Mode

All specifications at  $T_A = -40^\circ\text{C}$  to  $85^\circ\text{C}$ , IOVDD data sheet limits,  $V_{IL}$  and  $V_{IH}$  applied,  $V_{OL}$  and  $V_{OH}$  measured at datasheet limits, lumped capacitive load of 20 pF on output pins unless otherwise noted. See [Figure 3](#)<sup>(1)</sup>

SYMBOL	PARAMETER	CONDITIONS	IOVDD = 1.8 V		IOVDD = 3.3 V		UNIT
			MIN	MAX	MIN	MAX	
$t_d(\text{WS})$	BCLK to WCLK delay	50% of BCLK to 50% of WCLK		35		25	ns
$t_d(\text{DO-WS})$	WCLK to DOUT delay (For LJF Mode only)	50% of WCLK to 50% of DOUT		35		25	ns
$t_d(\text{DO-BCLK})$	BCLK to DOUT delay	50% of BCLK to 50% of DOUT		35		25	ns
$t_s(\text{DI})$	DIN setup		8		8		ns
$t_h(\text{DI})$	DIN hold		8		8		ns
$t_r$	Rise time	10%-90% Rise Time		8		4	ns
$t_f$	Fall time	90%-10% Fall Time		8		4	ns

(1) All timing specifications are measured at characterization but not tested at final test.

## 7.9 I<sup>2</sup>S/LJF/RJF Timing in Slave Mode

All specifications at  $T_A = -40^\circ\text{C}$  to  $85^\circ\text{C}$ , IOVDD data sheet limits,  $V_{IL}$  and  $V_{IH}$  applied,  $V_{OL}$  and  $V_{OH}$  measured at datasheet limits, lumped capacitive load of 20 pF on output pins unless otherwise noted. See [Figure 4](#)<sup>(1)</sup>

SYMBOL	PARAMETER	CONDITIONS	IOVDD = 1.8 V		IOVDD = 3.3 V		UNIT
			MIN	MAX	MIN	MAX	
$t_H(\text{BCLK})$	BCLK high period		40		30		ns
$t_L(\text{BCLK})$	BCLK low period		40		30		ns
$t_s(\text{WS})$	(WS)		8		8		ns
$t_h(\text{WS})$	WCLK hold		8		8		ns
$t_d(\text{DO-WS})$	WCLK to DOUT delay (For LJF Mode only)	50% of WCLK to 50% of DOUT		35		25	ns
$t_d(\text{DO-BCLK})$	BCLK to DOUT delay	50% of BCLK to 50% of DOUT		35		25	ns
$t_s(\text{DI})$	DIN setup		8		8		ns
$t_h(\text{DI})$	DIN hold		8		8		ns
$t_r$	Rise time	10%-90% Rise Time		8		4	ns
$t_f$	Fall time	90%-10% Fall Time		8		4	ns

(1) All timing specifications are measured at characterization but not tested at final test.

## 7.10 DSP Timing in Master Mode

All specifications at  $T_A = -40^\circ\text{C}$  to  $85^\circ\text{C}$ , IOVDD data sheet limits,  $V_{IL}$  and  $V_{IH}$  applied,  $V_{OL}$  and  $V_{OH}$  measured at datasheet limits, lumped capacitive load of 20 pF on output pins unless otherwise noted. See [Figure 5](#)

SYMBOL	PARAMETER	CONDITIONS	IOVDD = 1.8 V		IOVDD = 3.3 V		UNIT
			MIN	MAX	MIN	MAX	
$t_d(\text{WS})$	BCLK to WCLK delay	50% of BCLK to 50% of WCLK		35		25	ns
$t_d(\text{DO-BCLK})$	BCLK to DOUT delay	50% of BCLK to 50% of DOUT		35		25	ns
$t_s(\text{DI})$	DIN setup		8		8		ns
$t_h(\text{DI})$	DIN hold		8		8		ns
$t_r$	Rise time	10%-90% Rise Time		8		4	ns
$t_f$	Fall time	90%-10% Fall Time		8		4	ns

### 7.11 DSP Timing in Slave Mode

All specifications at 25°C, IOVDD = 1.8 V Ssee Figure 6<sup>(1)</sup>

SYMBOL	PARAMETER	CONDITIONS	IOVDD=1.8V		IOVDD=3.3V		UNIT
			MIN	MAX	MIN	MAX	
$t_{H(BCLK)}$	BCLK high period		40		30		ns
$t_{L(BCLK)}$	BCLK low period		40		30		ns
$t_s(WS)$	WCLK seutp		8		8		ns
$t_h(WS)$	WCLK hold		8		8		ns
$t_d(DO-BCLK)$	BCLK to DOUT delay (For LJF Mode only)	50% BCLK to 50% DOUT		35		25	ns
$t_s(DI)$	DIN setup		8		8		ns
$t_h(DI)$	DIN hold		8		8		ns
$t_r$	Rise time	10%-90% Rise Time		8		4	ns
$t_f$	Fall time	90%-10% Fall Time		8		4	ns

(1) All timing specifications are measured at characterization but not tested at final test.

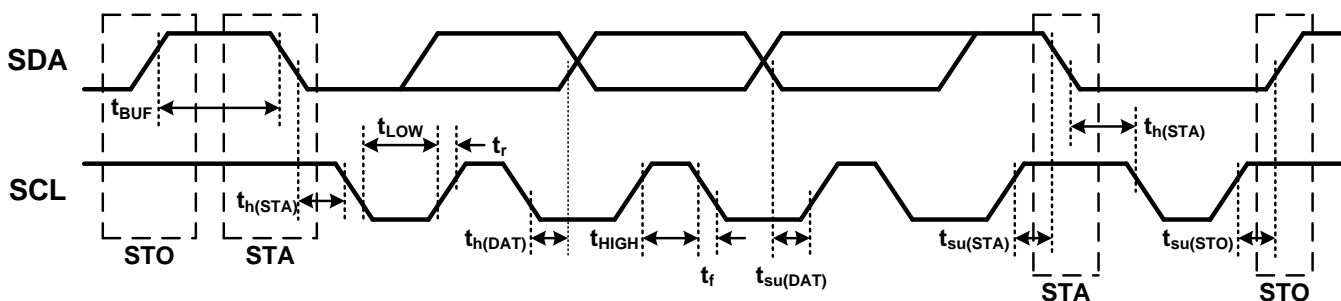

Figure 1. I<sup>2</sup>C Timing

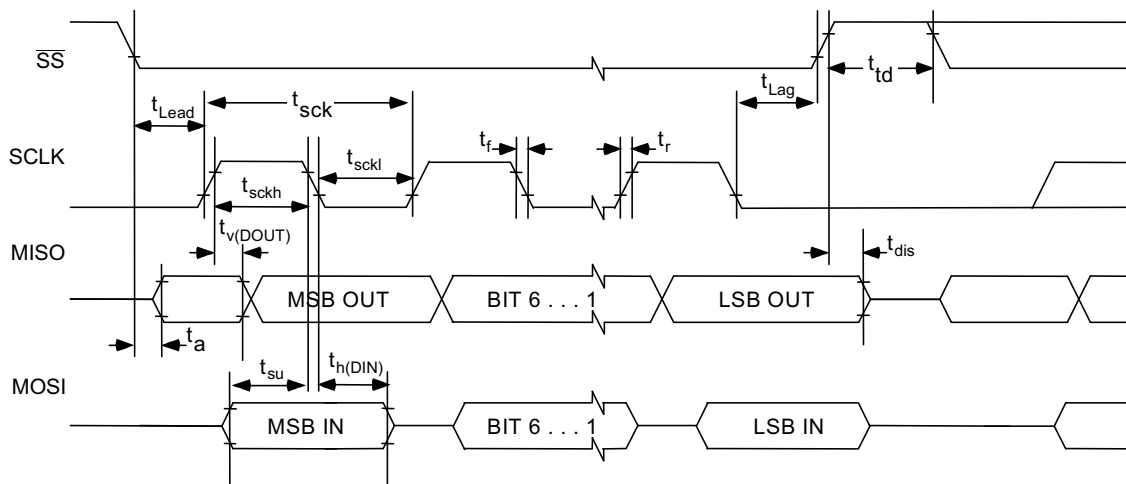
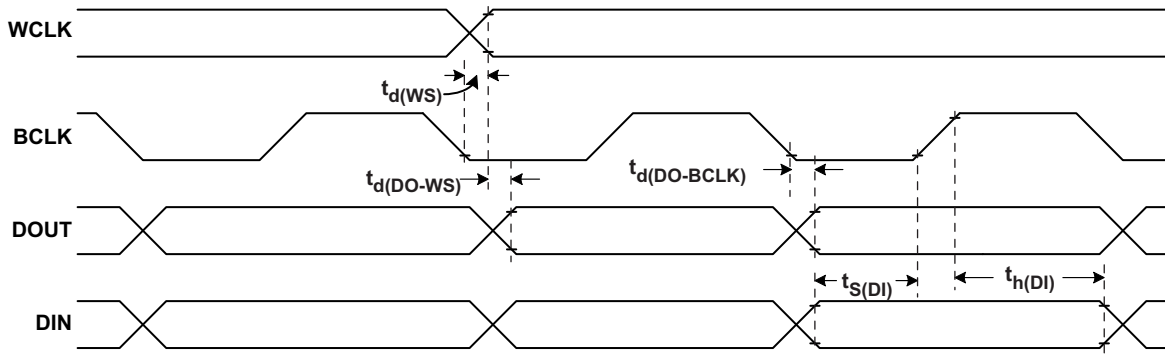
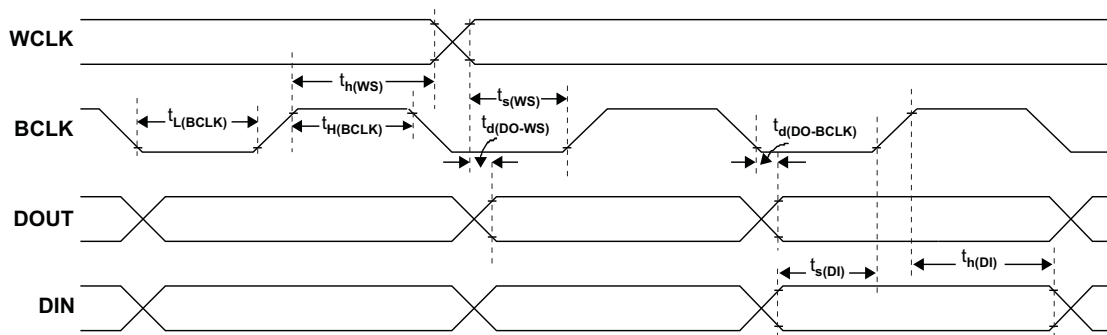
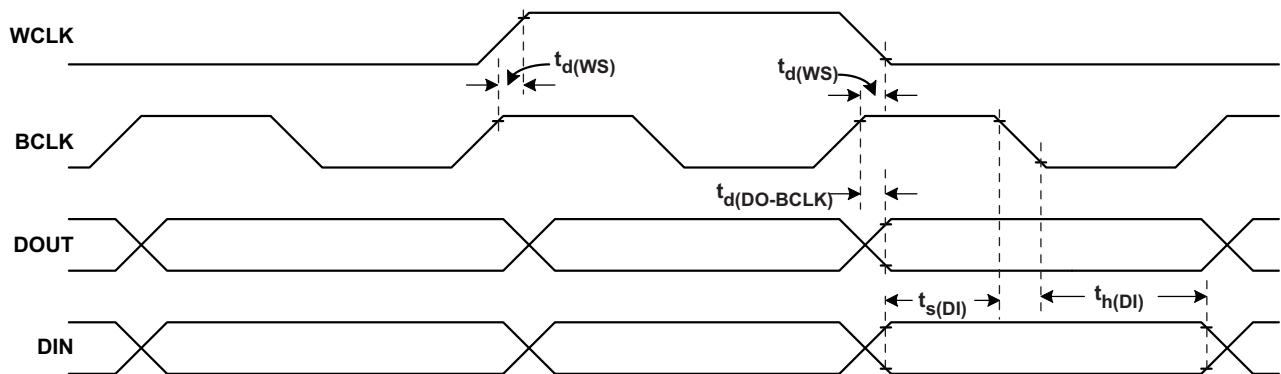
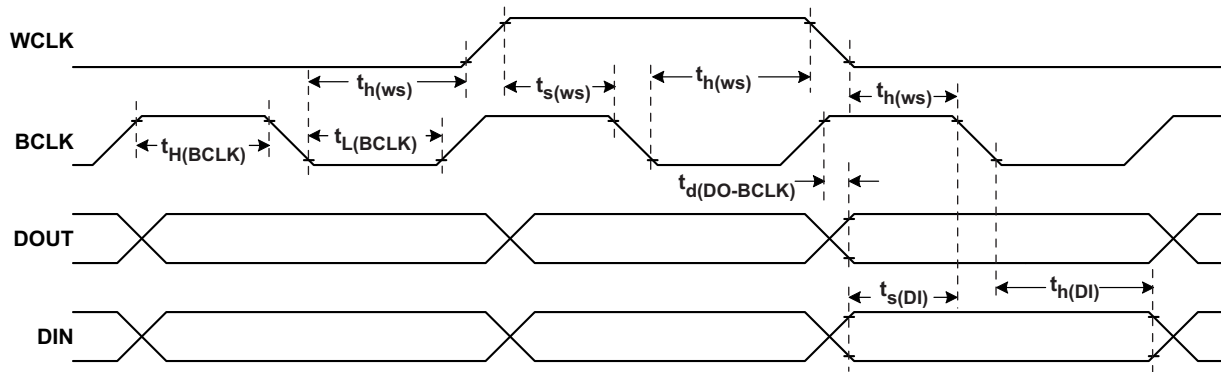

Figure 2. SPI Interface Timing Diagram

**Figure 3. I<sup>2</sup>S/LJF/RJF Timing in Master Mode**

**Figure 4. I<sup>2</sup>S/LJF/RJF Timing in Slave Mode**

**Figure 5. DSP Timing in Master Mode**



**Figure 6. DSP Timing in Slave Mode**

### 7.12 Typical Characteristics

VBAT = 3.6 V, AVDD = IOVDD = 1.8 V,  $\overline{\text{RESET}}$  = IOVDD,  $R_L = 8 \Omega + 33 \mu\text{H}$ , I<sup>2</sup>S digital input, ROM mode 1 (unless otherwise noted).

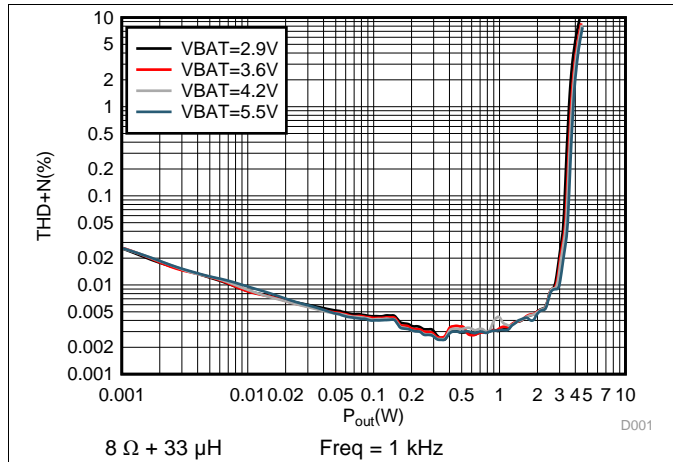

Figure 7. THD+N vs Output Power

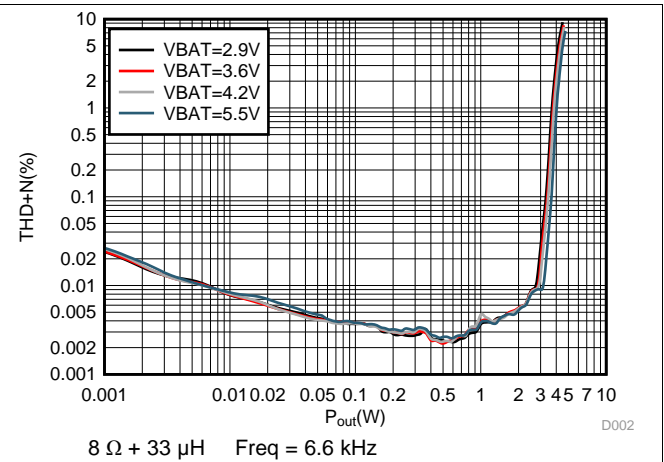

Figure 8. THD+N vs Output Power

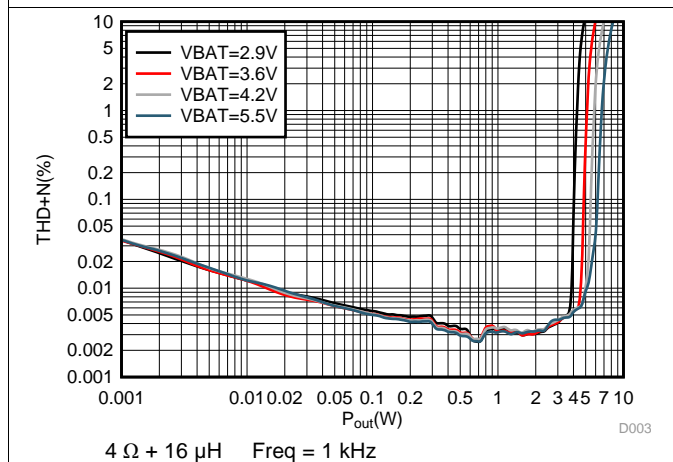

Figure 9. THD+N vs Output Power

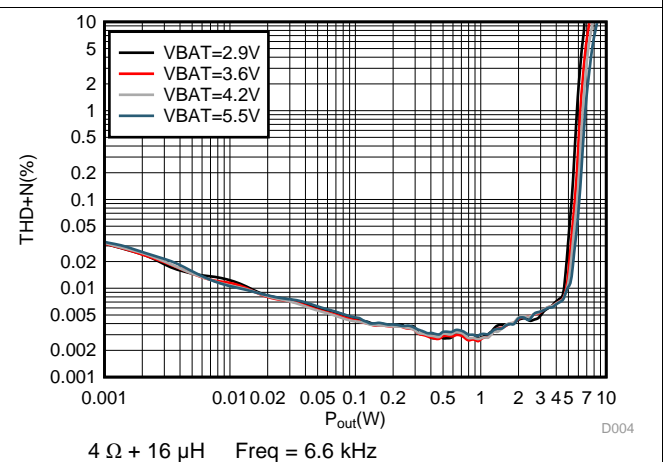

Figure 10. THD+N vs Output Power

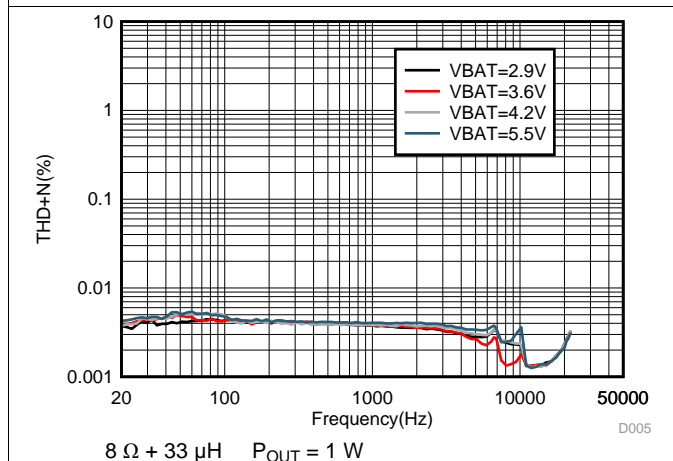

Figure 11. THD+N vs Frequency

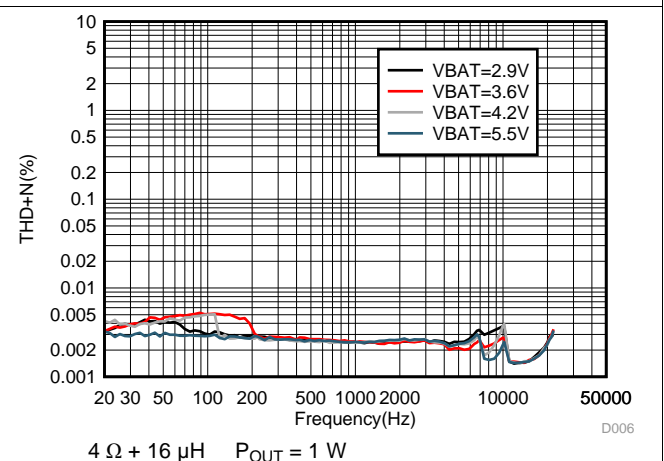

Figure 12. THD+N vs Frequency

Typical Characteristics (continued)

VBAT = 3.6 V, AVDD = IOVDD = 1.8 V,  $\overline{\text{RESET}}$  = IOVDD,  $R_L = 8 \Omega + 33 \mu\text{H}$ , I<sup>2</sup>S digital input, ROM mode 1 (unless otherwise noted).

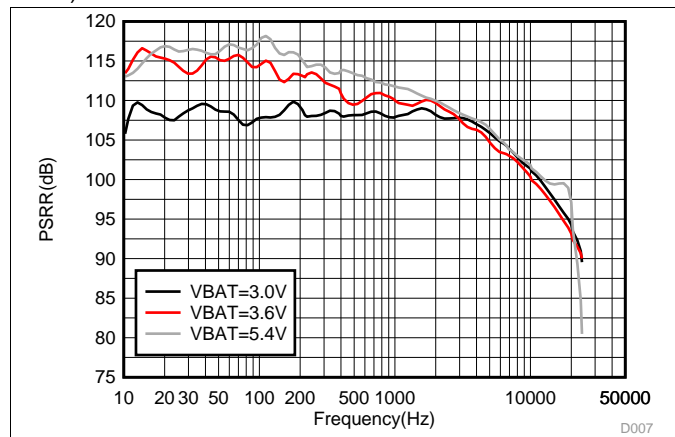

Figure 13. VBAT Supply Ripple Rejection vs Frequency

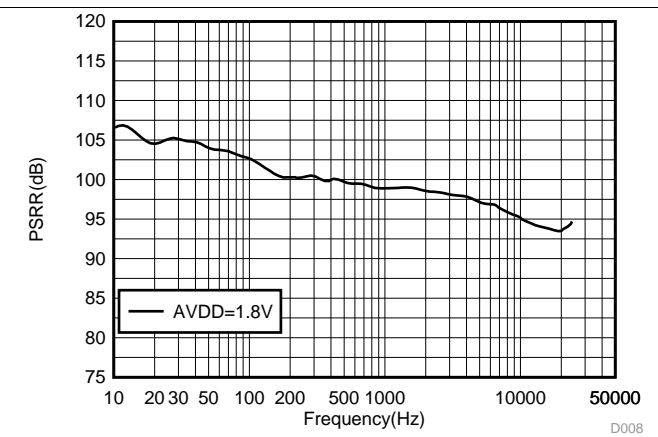

Figure 14. AVDD Supply Ripple Rejection vs Frequency

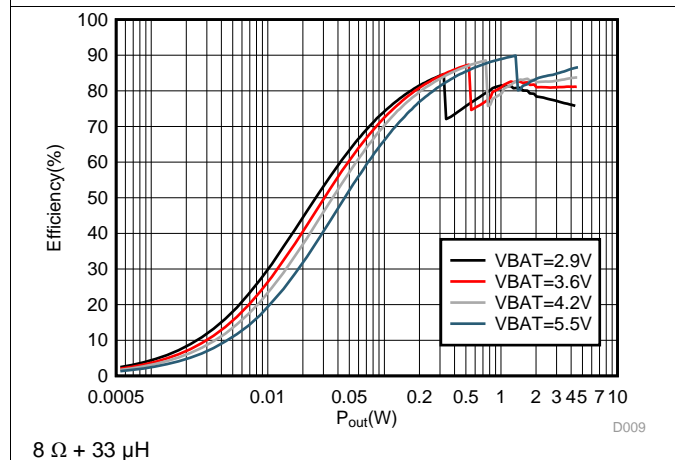

Figure 15. Efficiency vs Output Power

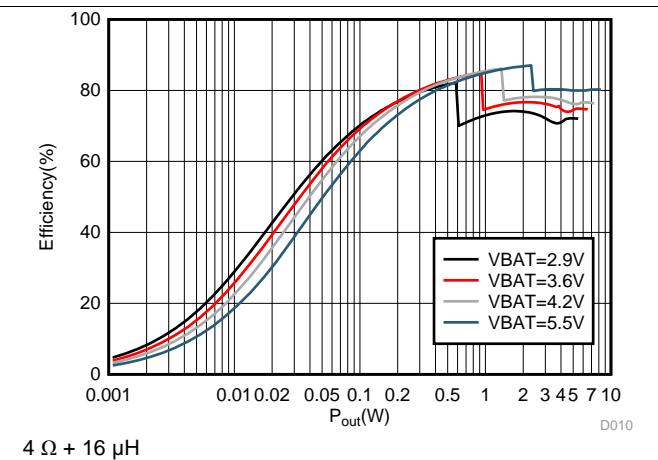

Figure 16. Efficiency vs Output Power

## 8 Parameter Measurement Information

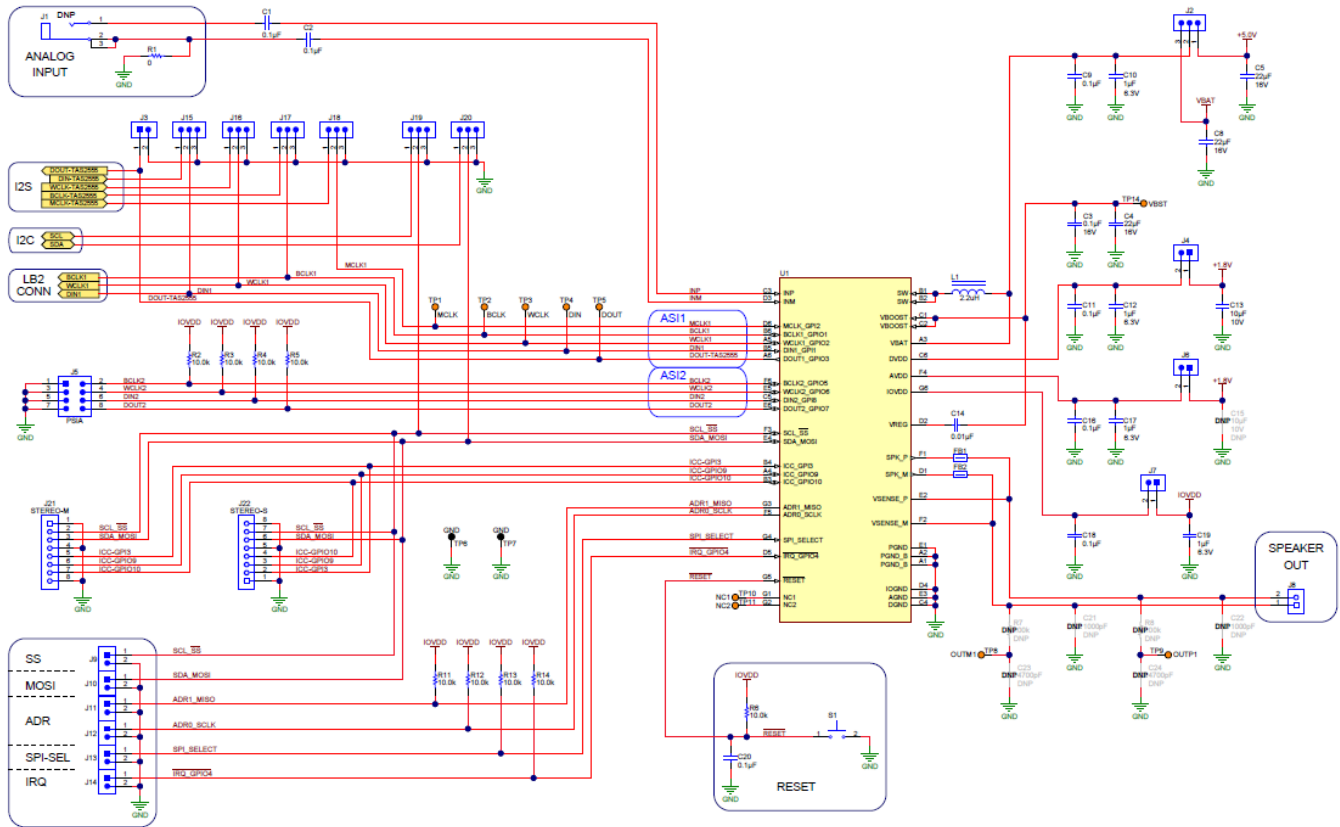

Figure 17. TAS2555 Test Circuit

All typical characteristics for the devices are measured using the Bench EVM and an Audio Precision SYS-2722 Audio Analyzer. A PSIA interface is used to allow the I<sup>2</sup>S interface to be driven directly into the SYS-2722. Speaker output terminals are connected to the Audio-Precision analyzer analog inputs through a differential-to-single ended(D2S) filter as shown below. The D2S filter contains a 1st order Passive pole at 120 kHz. The D2S filter ensures the TAS2555 high performance class-D amplifier sees a fully differential matched loading at its outputs. This prevents measurement errors due to loading effects of AUX-0025 filter on the class-D outputs.

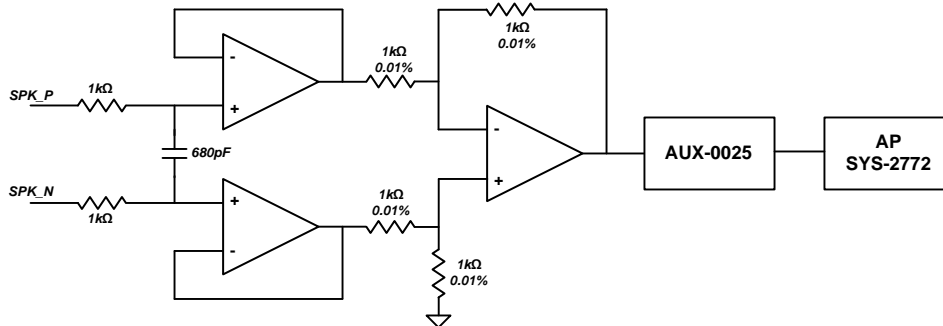

Figure 18. Differential To Single Ended (D2S) Filter

## 9 Detailed Description

### 9.1 Overview

The TAS2555 device is a state-of-the-art Class-D audio amplifier which is a full system on a Chip (SoC). The device features a ultra low-noise audio DAC and Class-D power amplifier which incorporates speaker voltage and current sensing feedback. An on-chip, low-latency DSP supports Texas Instruments SmartAmp speaker protection algorithms to maximizes loudness while maintaining safe speaker conditions. A smart integrated multi-level Class-H boost converter maximizes system efficiency at all times by tracking the required output voltage. The TAS2555 drives up to 3.8 W from a 4.2-V supply into an 8- $\Omega$  speaker with 1% THD, or up to up 5.7 W into a 4- $\Omega$  speaker with 1% THD.

The TAS2555 device, with final processed digital output, can also be used to increase loudness and clarity in both Noise Canceling / Echo Cancelling speaker phone applications as well as for music or other sound applications. The TAS2555 device supports analog inputs for applications such as FM chips with analog output only, but with reduction in performance and speaker protection. The TAS2555 device accepts input audio data rates from 8 kHz to 96 kHz using ROM modes to fully support both speaker-phone and music applications. When speaker protection system is running the maximum sampling rate is limited to 48 kHz.

The multi-level Class-H boost converter generates the Class-D amplifier supply rail. When the audio signal requires a output power below VBAT, the boost improves system efficiency by deactivating and connecting VBAT directly to the Class-D amplifier supply. When higher audio output power is required, the boost quickly activates and provides a much louder and much clearer signal than can be achieved in any standard amplifier speaker system design approach. A boost inductor of 1 $\mu$ H can be used with a slight increase in boost ripple.

On-chip brown out detection system shutdown down audio at the user configurable threshold to avoid undesired system reset. In addition, an AGC can be selected to minimize clipping events when a lower power supply voltage is provided to the Class-D speaker driver. When this supply voltage drops below the proper level then under-voltage protection will be tripped. All protection statuses are available via register reads.

The Class-D output switching frequency is synchronous with the digital input audio sample rate to avoid left and right PWM frequency differences from beating in stereo applications. PWM Edge rate control and Spread Spectrum features are available if further EMI reduction is desired in the user's system.

The interrupt request pin, IRQ, indicates a device error condition. The interrupt flag condition or conditions are selectable via I<sup>2</sup>C and include: thermal overload, Class-D over-current, VBAT level low, VBOOST level Low, and PLL out-of-lock conditions. The IRQ signal is active-high for an interrupt request and active-high during normal operation. This behavior can be changed by a register setting to tri-state the pin during normal operation to allow the IRQ pin to be tied in parallel with other active-low interrupt request pins on other devices in the system.

Stereo configuration can be achieved with two TAS2555 devices by using the ADR0\_SCLK and ADR1\_MISO pins to set different I<sup>2</sup>C addresses in I<sup>2</sup>C mode or the SCL\_SSZ chip enable pin in SPI mode. Refer to the [General I<sup>2</sup>C Operation](#) or [General SPI Operation](#) sections for more details.

## 9.2 Functional Block Diagram

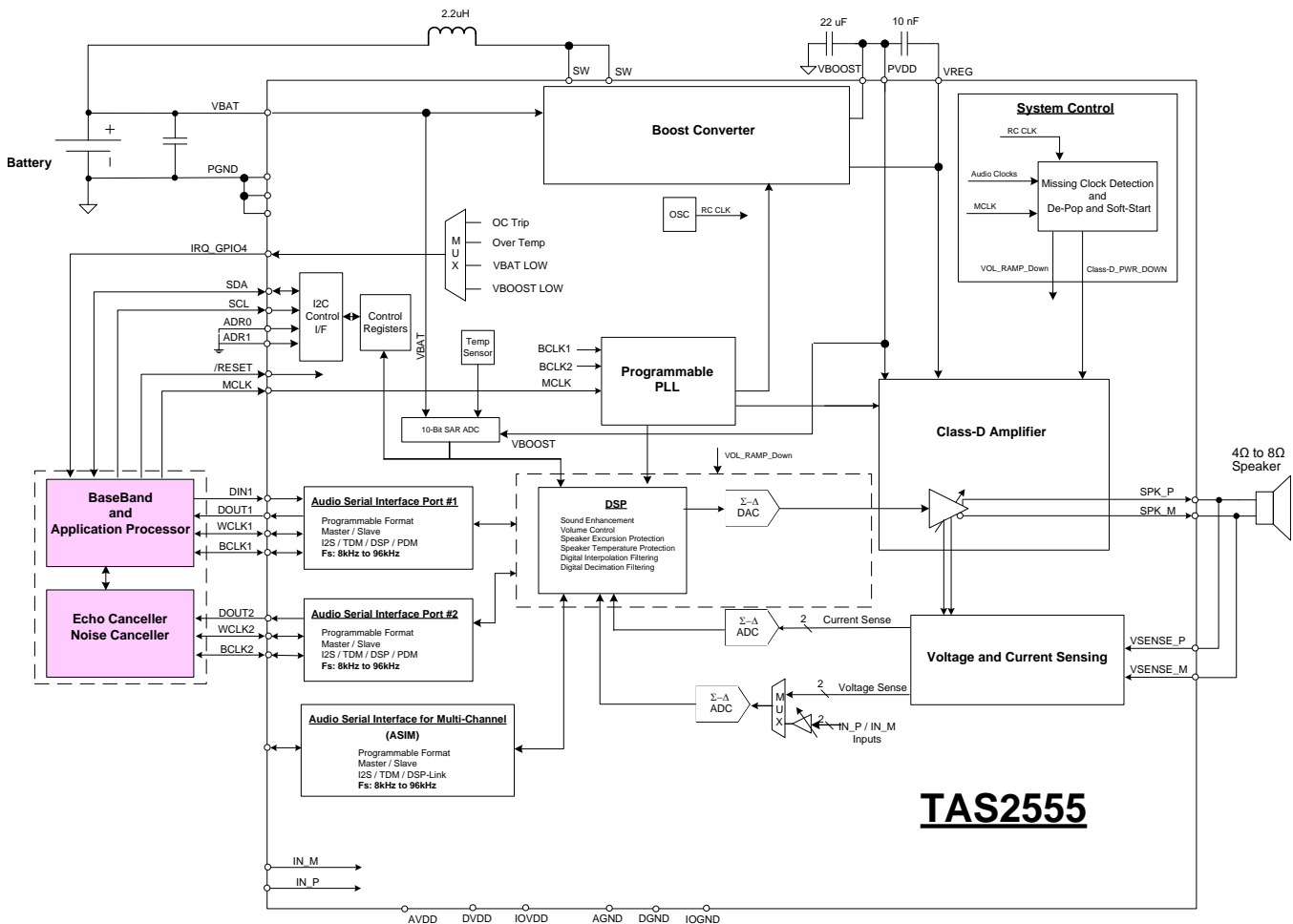

## 9.3 Feature Description

### 9.3.1 General I<sup>2</sup>C Operation

The TAS2555 device operates as an I<sup>2</sup>C slave over the IOVDD voltage range. It is adjustable to one of four I<sup>2</sup>C addresses. This allows multiple TAS2555 devices in a system to connect to the same I<sup>2</sup>C bus. The I<sup>2</sup>C pins are fail-safe. If the part has not power or is in shutdown the I<sup>2</sup>C pins will not have impact the I<sup>2</sup>C bus allowing it to remain useable.

To configure the TAS2555 for I<sup>2</sup>C operation set the SPI\_SELECT pin to ground. The I<sup>2</sup>C address can then be set using pins ADR0\_SCLK and ADR1\_MSIO. The pins configure the two LSB bits of the following 7-bit binary address A6-A0 of 10011xx. This permits the I<sup>2</sup>C address of TAS2555 to be 0x4C(7bit) through 0x4F(7-bit). For example, if both ADR0\_SCLK and ADR1\_MSIO are connected to ground the I<sup>2</sup>C address for the TAS2555 would be 0x4C(7bit). This is equivalent to 0x98 (8-bit) for writing and 0x99 (8-bit) for reading.

The I<sup>2</sup>C bus employs two signals, SDA (data) and SCL (clock), to communicate between integrated circuits in a system. The corresponding pins on the TAS2555 for the two signals are SDA\_MOSI and SCL\_SSZ. The bus transfers data serially, one bit at a time. The address and data 8-bit bytes are transferred most-significant bit (MSB) first. In addition, each byte transferred on the bus is acknowledged by the receiving device with an acknowledge bit. Each transfer operation begins with the master device driving a start condition on the bus and ends with the master device driving a stop condition on the bus. The bus uses transitions on the data terminal (SDA) while the clock is at logic high to indicate start and stop conditions. A high-to-low transition on SDA indicates a start, and a low-to-high transition indicates a stop. Normal data-bit transitions must occur within the low time of the clock period. [Figure 19](#) shows a typical sequence.

## Feature Description (continued)

The master generates the 7-bit slave address and the read/write (R/W) bit to open communication with another device and then waits for an acknowledge condition. The device holds SDA low during the acknowledge clock period to indicate acknowledgment. When this occurs, the master transmits the next byte of the sequence. Each device is addressed by a unique 7-bit slave address plus R/W bit (1 byte). All compatible devices share the same signals via a bi-directional bus using a wired-AND connection.

Use external pull-up resistors for the SDA and SCL signals to set the logic-high level for the bus. Use pull-up resistors between 660 Ω and 4.7 kΩ. Do not allow the SDA and SCL voltages to exceed the device supply voltage, IOVDD.

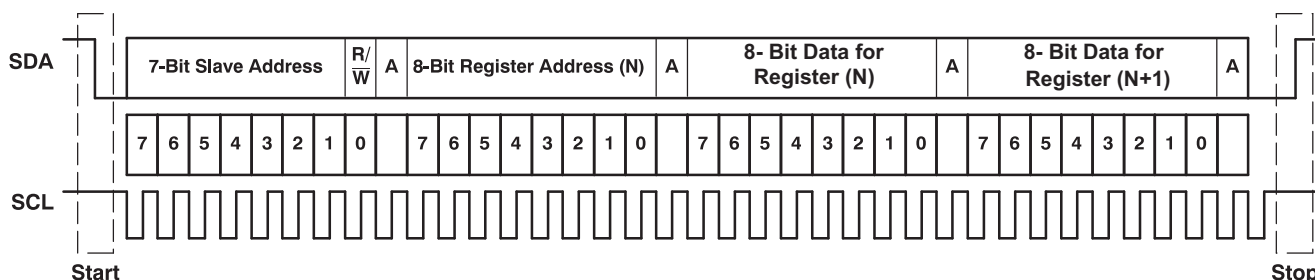

Figure 19. Typical I<sup>2</sup>C Sequence

There is no limit on the number of bytes that can be transmitted between start and stop conditions. When the last word transfers, the master generates a stop condition to release the bus. Figure 19 shows a generic data transfer sequence.

### 9.3.2 Single-Byte and Multiple-Byte Transfers

The serial control interface supports both single-byte and multiple-byte read/write operations for all registers. During multiple-byte read operations, the TAS2555 responds with data, a byte at a time, starting at the register assigned, as long as the master device continues to respond with acknowledges.

The TAS2555 supports sequential I<sup>2</sup>C addressing. For write transactions, if a register is issued followed by data for that register and all the remaining registers that follow, a sequential I<sup>2</sup>C write transaction has taken place. For I<sup>2</sup>C sequential write transactions, the register issued then serves as the starting point, and the amount of data subsequently transmitted, before a stop or start is transmitted, determines to how many registers are written.

### 9.3.3 Single-Byte Write

As shown in Figure 20, a single-byte data-write transfer begins with the master device transmitting a start condition followed by the I<sup>2</sup>C device address and the read/write bit. The read/write bit determines the direction of the data transfer. For a write-data transfer, the read/write bit must be set to 0. After receiving the correct I<sup>2</sup>C device address and the read/write bit, the TAS2555 responds with an acknowledge bit. Next, the master transmits the register byte corresponding to the device internal memory address being accessed. After receiving the register byte, the device again responds with an acknowledge bit. Finally, the master device transmits a stop condition to complete the single-byte data-write transfer.

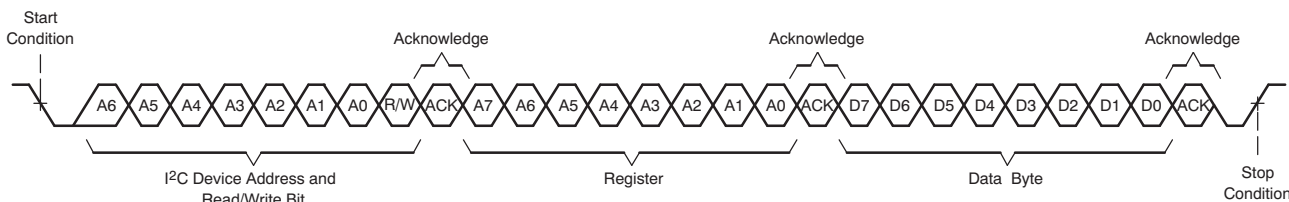

Figure 20. Single-Byte Write Transfer

## Feature Description (continued)

### 9.3.4 Multiple-Byte Write and Incremental Multiple-Byte Write

A multiple-byte data write transfer is identical to a single-byte data write transfer except that multiple data bytes are transmitted by the master device to the TAS2555 as shown in Figure 21. After receiving each data byte, the device responds with an acknowledge bit.

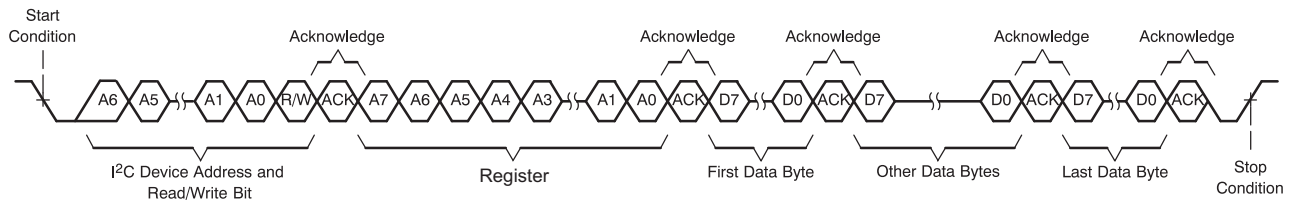

Figure 21. Multiple-Byte Write Transfer

### 9.3.5 Single-Byte Read

As shown in Figure 22, a single-byte data-read transfer begins with the master device transmitting a start condition followed by the I<sup>2</sup>C device address and the read/write bit. For the data-read transfer, both a write followed by a read are actually done. Initially, a write is done to transfer the address byte of the internal memory address to be read. As a result, the read/write bit is set to a 0.

After receiving the TAS2555 address and the read/write bit, the device responds with an acknowledge bit. The master then sends the internal memory address byte, after which the device issues an acknowledge bit. The master device transmits another start condition followed by the TAS2555 address and the read/write bit again. This time, the read/write bit is set to 1, indicating a read transfer. Next, the TAS2555 transmits the data byte from the memory address being read. After receiving the data byte, the master device transmits a not-acknowledge followed by a stop condition to complete the single-byte data read transfer.

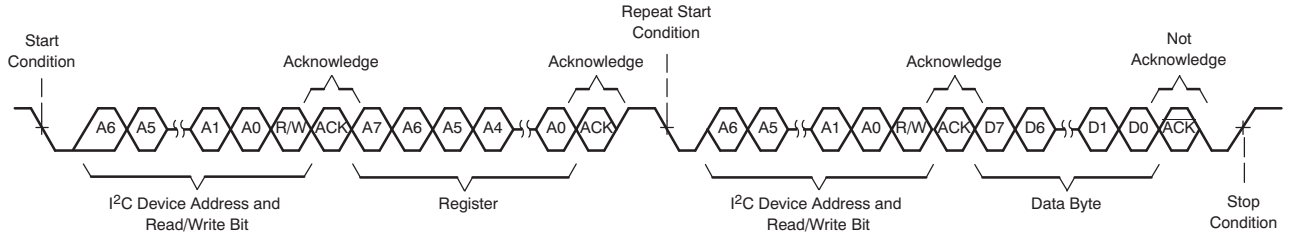

Figure 22. Single-Byte Read Transfer

### 9.3.6 Multiple-Byte Read

A multiple-byte data-read transfer is identical to a single-byte data-read transfer except that multiple data bytes are transmitted by the TAS2555 to the master device as shown in Figure 23. With the exception of the last data byte, the master device responds with an acknowledge bit after receiving each data byte.

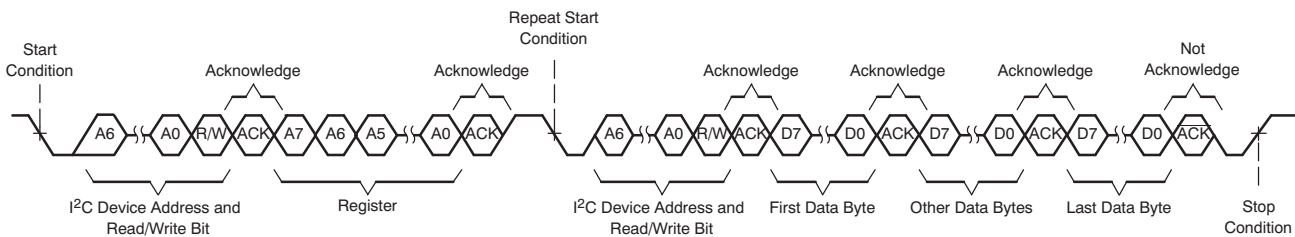

Figure 23. Multiple-Byte Read Transfer

## Feature Description (continued)

### 9.3.7 General SPI Operation

The TAS2555 operates as an SPI slave over the IOVDD voltage range.

### 9.3.8 Class-D Edge Rate Control

The edge rate of the Class-D output is controllable via I<sup>2</sup>C register B0\_P0\_R6[2:0]. This allows users the ability to adjust the switching edge rate of the Class-D amplifier, trading off some efficiency for lower EMI. Table 1 lists the typical edge rates. The default edge rate of 14ns passes EMI testing. The default value is recommended but may be changed if required.

**Table 1. Class-D Edge Rate Control**

DAC_EDGE BYTE: DAC_EDGE[2:0]	t <sub>R</sub> AND t <sub>F</sub> (TYPICAL)
010	29 ns
011	25 ns
100	14 ns (default)
101	13 ns
110	12 ns
111	11 ns

### 9.3.9 Battery Tracking AGC

The TAS2555 device monitors battery voltage and the audio signal to automatically decrease gain when the battery voltage is low and audio output power is high. This provides louder audio while preventing early shutdown at end-of-charge battery voltage levels. The battery tracking AGC starts to attenuate the signal once the voltage at the Class-D output exceeds V<sub>LIM</sub> for a given battery voltage (VBAT). If the Class-D output voltage is below the V<sub>LIM</sub> value, no attenuation occurs. If the Class-D output exceeds the V<sub>LIM</sub> value the AGC starts to attack the signal and reduce the gain until the output is reduced to V<sub>LIM</sub>. Once the signal returns below V<sub>LIM</sub> plus some hysteresis the gain reduction decays. The V<sub>LIM</sub> is constant above the user configurable inflection point. Below the inflection point the V<sub>LIM</sub> is reduced by a user configurable slope in relation to the battery voltage. The attack time, decay time, inflection point and V<sub>LIM</sub>/VBAT slope below the inflection point are user configurable. The parameters for the Battery Tracking AGC are part of the DSP core and can be set using the [PurePath™ Console 3 Software TAS2555 Application](#) software for the TAS2555 device part under the Device Control Tab. Below a VBAT level of 2.9 V, the boost will turn on to ensure correct operation but results in increased current consumption. The device is functional until the set brownout level is reached and the device shuts down. The minimum brownout voltage is 2.7 V.

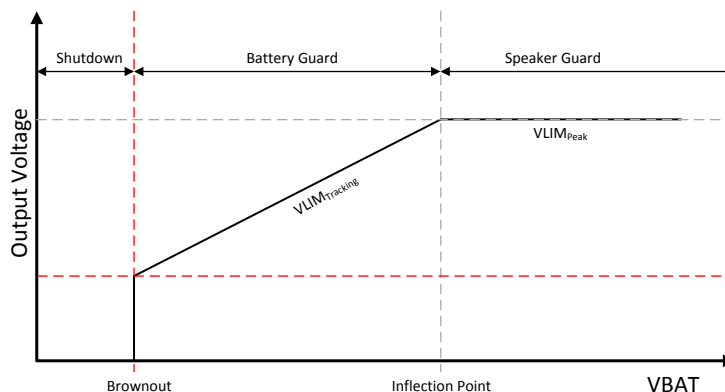

**Figure 24. V<sub>LIM</sub> versus Supply Voltage (VBAT)**

### 9.3.10 Configurable Boost Current Limit (ILIM)

The TAS2555 device has a configurable boost current limit (ILIM). The default current limit is 3 A but this limit may be set lower based on selection of passive components connected to the boost. The TAS2555 device supports 4 different boost limits.

**Table 2. Current Limit Settings**

CURRENT LIMIT REGISTER B0_P0_R43_D[1:0]	BOOST CURRENT LIMIT (ILIM) (A)
00	1.5
01	2.0
10	2.5
11	3.0 (default)

### 9.3.10.1 Fault Protection

The TAS2555 device has several protection blocks to prevent damage. Those blocks including how to resume from a fault are presented in this section.

#### 9.3.10.1.1 OverCurrent

The TAS2555 device has an integrated overcurrent protection that is enabled once the Class-D is powered up. A fault on the Class-D output causing a large current in the range of 3 A to 5 A triggers the overcurrent fault. Once the fault is detected the TAS2555 device disables the audio channel and power down the Class-D amplifier. When an over-current event occurs, a status flag at B0\_P0\_R104[7] is set. This register is sticky and the bit remains high for as long as it is not read, or the device is not reset. The overcurrent event can also be used to generate an interrupt if required. Refer to "IRQ and flags" section for more details. To re-enable the audio channel after a fault the Class-D the device must be hardware or software reset and the TAS2555 configuration must be re-loaded.

#### 9.3.10.1.2 Analog Undervoltage

The TAS2555 device has an integrated undervoltage protection on the analog power supply lines AVDD and VBAT. The undervoltage limit fault is triggered when AVDD is less than 1.5 V or when VBAT is less than 2.4 V. Once the fault is detected the TAS2555 device will disable the audio channel and power down the Class-D amplifier. When an under-voltage event occurs, a status flag at B0\_P0\_R104[6] is set. This register is sticky and the bit will remain high for as long as it is not read, or the device is not reset. The undervoltage event can also be used to generate an interrupt if required. Refer to [IRQs and Flags](#) section for more details. To re-enable the audio channel after a fault the Class-D must be re-enabled by setting B0\_P0\_R5[7]=1. All other configurations are preserved and the audio channel will power up with the last configured settings.

#### 9.3.10.1.3 Overtemperature

The TAS2555 device has an integrated overtemperature protection that is enabled once the Class-D is powered up. If the device internal junction temperature exceeds the safe operating region it will trigger the overtemperature fault. Once the fault is detected the TAS2555 device disables the audio channel and power down the Class-D amplifier. The device waits until the user reads the overtemperature flag in B0\_P0\_R104[4] to re-enable the Class-D amplifier if the junction temperature returns into a safe operating region. When an over-temperature event occurs, a status flag at B0\_P0\_R104[4] is set. This register is sticky and the bit will remain high for as long as it is not read, or the device is not reset. The overtemperature event can also be used to generate an interrupt if required. Refer to [IRQs and Flags](#) section for more details. The overtemperature automatic re-enable can be disabled by setting B0\_P2\_R9[2]=1. If the automatic re-enable is disabled, to re-enable the audio channel after the overtemperature fault the Class-D must be re-enabled by setting B0\_P0\_R5[7]=1. All other configurations are preserved and the audio channel will power up with the last configured settings.

#### 9.3.10.1.4 Clocking Faults

The TAS2555 device has two clock error detection blocks. The first is on the Audio Serial Interfaces (ASI). If a clock error is detected on the ASI interfaces audio artifacts can occur at the Class-D output. When enabled the ASI clock error detection can mute the device and shutdown the Class-D and DSP core. The clock error detection block is enabled by setting register bit B0\_P0\_R44[1]=1. The ASI1 or ASI2 clocks can be routed to the block for detection using register B0\_P0\_R44[4]. Additionally, the clock error can be routed to an interrupt pin and the sticky bit at register B0\_P0\_R104[5] indicates the clock error occurred. The second clock error detection block can monitor the DAC, ADC, and PLL clocks. When a clock error is detected the output is soft-muted and the Class-D powered down. This clock error detection is enabled using register bit B0\_P0\_R44[0], can be routed to interrupt pin and is indicated in the sticky bit B0\_P0\_R104[2].

When a clocking error occurs the following sequence should be performed to restart the device.

- Clear the clock error interrupts by reading the sticky flags at registers B0\_P0\_R104 and B0\_P0\_R108
- Disable the clock error detection blocks by writing B0\_P0\_R44[7:0]=0x00 as the internal dividers will be stopped on error detection.
- Shutdown by writing B0\_P0\_R4=0x00 and B0\_P0\_R5=0x00
- Re-power appropriate devices in the same registers
- Re-enable the clock error detection blocks in register B0\_P0\_R44

### 9.3.10.2 Brownout

The TAS2555 device has an integrated brownout system to shutdown the device when the battery voltage drops to an insufficient level. This user configurable level can be set under Device Control in the [PurePath™ Console 3 Software TAS2555 Application](#). When brownout event occurs a status flag B0\_P0\_R104[3] is set. This register is sticky and the bit remains high for as long as it is not read, or the device is not reset. The brownout event can also be used to generate an interrupt if required. Refer to [IRQs and Flags](#) section for more details. Once the battery voltage drops below the defined threshold the following actions occur.

- The audio playback is muted in a graceful soft-stepping manner
- DSP, clock dividers, and analog blocks are powered down. B0\_P0\_R4[7:3]=00000 and B0\_P0\_R5[7:0]=0x00
- Sticky bit B0\_P0\_R104[3] is set

Once the host is aware of the brownout it should write B0\_P0\_R4[0] =0 to put the TAS2555 device in software shutdown and enter low power mode. Once the battery supply is stable above the defined brownout threshold the host can re-enable the device using the Power Control Registers B0\_P0\_R4 and B0\_P0\_R5.

### 9.3.10.3 Spread Spectrum vs Synchronized

The Class-D switching frequency can be selected to work in two different modes of operations. This configuration must be done before powering up the audio channel. The first is a synchronized mode where the Class-D frequency is synchronized frequency to audio input sample rate. This is the default mode of operation and should be used in stereo applications to avoid inter-modulation beating of the Class-D frequency from multiple chips. The Class-D switching frequency in this mode can be configured as 384 kHz for 352.8 kHz. The 384 kHz frequency is the default mode of operation, and can be used for input signals running on clock rates of 48 kHz or its sub-multiples. For input signals running on clock rate of 44.1 kHz and its sub-multiples, the switching frequency can be selected as 352.8 kHz by setting B0\_P2\_R6[4]=1.

The second mode is spread-spectrum mode used to reduce wideband spectral content, improving EMI emissions radiated by the speaker. In this mode, the Class-D switching frequency varies +-5% about a 384 kHz center frequency. This mode can be configured by setting B0\_P0\_R40[0]=1 and B100\_P0\_R40[7]=0. Both these registers should be written before powering up the audio channel.

### 9.3.10.4 IRQs and Flags

Internal device flags such as overcurrent, under-voltage, etc can be routed as interrupts. The device has 4 interrupts that can be routed to any of the 10 GPIO pins. If more than one flag is assigned to the same interrupt the interrupt output is the logical OR-ing of all flags. If multiple flags are assigned to the same interrupt the host should then query the flags sticky register to determine which event triggered the interrupt. The 10 GPIO pins can be configured for any interrupt and can be configured using B0\_P1\_R61 thru B0\_P1\_R70.

**Table 3. Interrupt Registers**

Flag Name	Flag Description	Sticky Register Bit	Register to Route Flag to Interrupt
Flag 1	Over Current	B0_P0_R104[7]	B0_P1_R108[6:4]
Flag 2	Under Voltage	B0_P0_R104[6]	B0_P1_R108[2:0]
Flag 3	Clock Error Detection 1	B0_P0_R104[5]	B0_P1_R109[6:4]
Flag 4	Over Temperature	B0_P0_R104[4]	B0_P1_R109[2:0]
Flag 5	Brownout	B0_P0_R104[3]	B0_P1_R110[6:4]
Flag 6	Clock Error Detection 2	B0_P0_R104[2]	B0_P1_R110[2:0]
Flag 7	SAR Complete	B0_P0_R104[1]	B0_P1_R111[6:4]

For example, to route the Brownout and Under Voltage flags to GPIO5 (Pin IRQ\_GPIO5) the following register settings would be used. The flag Brownout would be routed to Interrupt 1 by setting B0\_P1\_R110[6:4]=001 and flag Under Voltage would be also routed to interrupt 1 by setting B0\_P1\_R108[2:0]=001. The pin IRQ\_GPIO5 would be set to use interrupt 1 by setting B0\_P1\_R64[4:0]=0x07

### 9.3.10.5 Software Reset

The TAS2555 device internal logic must be initialized to a known condition for proper device function by doing a software reset. Performing software reset after a hardware reset is mandatory for reliable device boot up. To perform software reset write '1' to B0\_P0\_R1\_D0. After reset, all registers are initialized with default values as listed in the Register Map. After software reset is performed, no register read/write should be performed within 100us.

### 9.3.10.6 PurePath™ Console 3 Software TAS2555 Application

The TAS2555 device contains an integrated DSP processing engine for advance speaker protection. The advanced features and a significant portion of the device configuration is performed using this tool. The base software is called Pure Path Console 3 (PPC3). Once the software is downloaded and installed from the TI website, the TAS2555 application can be download from with-in the software. The datasheet refers to options that can be configured using the PPC3 software tool.

## 9.4 Device Functional Modes

### 9.4.1 Audio Digital I/O Interface

Audio data is transferred between the host processor and the TAS2555 device via the digital audio data serial interface, or audio bus. The audio bus on this device is flexible, including left or right-justified data options, support for I<sup>2</sup>S or PCM protocols, programmable data length options, a TDM mode for multichannel operation, very flexible master/slave configurability for each bus clock line, and the ability to communicate with multiple devices within a system directly.

The audio bus of the TAS2555 device can be configured for left or right-justified, I<sup>2</sup>S, DSP, or TDM modes of operation, where communication with standard telephony PCM interfaces is supported within the TDM mode. These modes are all MSB-first, with data width programmable as 16, 20, 24, or 32 bits by configuring Registers B0\_P1\_R1\_D[4:3] and B0\_P1\_R2\_D[4:3] for ASI1 and Registers B0\_P1\_R21\_D[4:3] and B0\_P1\_R22\_d[4:3] . In addition, the word clock and bit clock can be independently configured in either Master or Slave mode, for flexible connectivity to a wide variety of processors. The word clock is used to define the beginning of a frame, and may be programmed as either a pulse or a square-wave signal. The frequency of this clock corresponds to the maximum of the selected ADC and DAC sampling frequencies.

The bit clock is used to clock in and clock out the digital audio data across the serial bus. This signal can be programmed to generate variable clock pulses by controlling the bit-clock multiply-divide factor in Registers 0x08 through 0x10. The number of bit-clock pulses in a frame may require adjustment to accommodate various word-lengths as well as to support the case when multiple TAS2555 devices may share the same audio bus.

The TAS2555 device also includes a feature to offset the position of start of data transfer with respect to the word-clock. This offset is in number of bit-clocks and is programmed in Register 0x06.

To place the DOUT line into a Hi-Z (3-state) condition during all bit clocks when valid data is not being sent, set Register B0\_P1\_R1\_D[0] = 1 for ASI1 and Register B0\_P1\_R21[0] = 1. By combining this capability with the ability to program what bit clock in a frame the audio data begins, time-division multiplexing (TDM) can be accomplished. This enables the use of multiple devices on a single audio serial data bus. When the audio serial data bus is powered down while configured in master mode, the terminals associated with the interface are put into a Hi-Z output state.

#### 9.4.1.1 Right-Justified Mode (RJF)

Audio Serial Interface 1 can be put into Right Justified Mode by programming B0\_P1\_R1\_D[7:5] = 010 and B0\_P1\_R2\_D[7:5] = 010 . Audio Serial Interface 2 can be put into Right Justified Mode by programming B0\_P1\_R21\_D[7:5] = 010 and B0\_P1\_R22\_D[7:5] = 010. In right-justified mode, the LSB of the left channel is valid on the rising edge of the bit clock preceding the falling edge of the word clock. Similarly, the LSB of the right channel is valid on the rising edge of the bit clock preceding the rising edge of the word clock.

**Device Functional Modes (continued)**

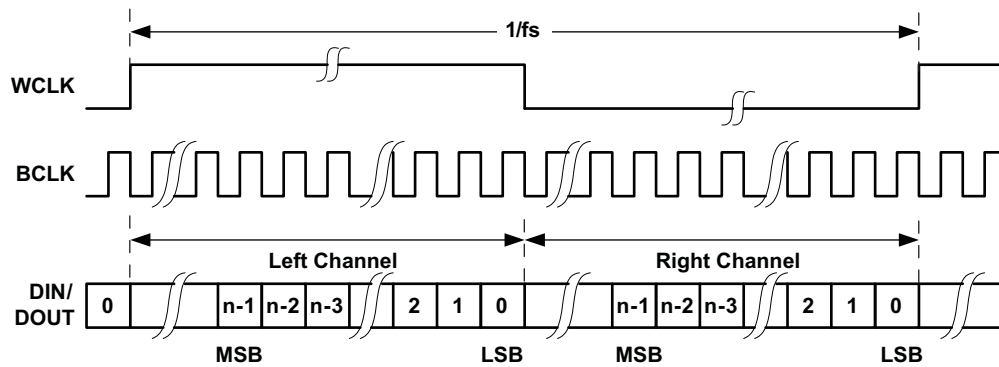

**Figure 25. Timing Diagram for Right-Justified Mode**

For right-justified mode, the number of bit-clocks per frame should be greater than twice the programmed word-length of the data.

## Device Functional Modes (continued)

### 9.4.1.2 Left-Justified Mode (LJF)

Audio Serial Interface 1 can be put into left-justified mode by programming  $B0\_P1\_R1\_D[7:5] = 011$  and  $B0\_P1\_R2\_D[7:5] = 011$ . Audio Serial Interface 2 can be put into left-justified mode by programming  $B0\_P1\_R21\_D[7:5] = 011$  and  $B0\_P1\_R22\_D[7:5] = 011$ . In left-justified mode, the MSB of the right channel is valid on the rising edge of the bit clock following the falling edge of the word clock. Similarly the MSB of the left channel is valid on the rising edge of the bit clock following the rising edge of the word clock.

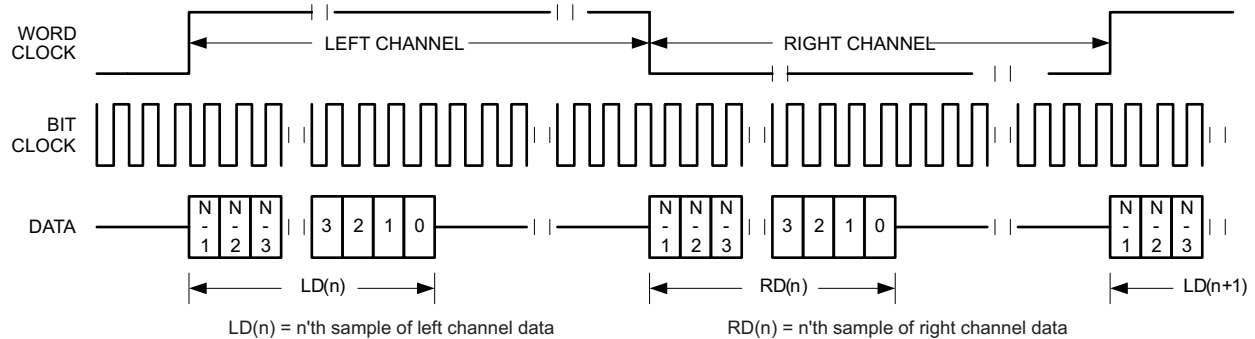

**Figure 26. Timing Diagram for Left-Justified Mode**

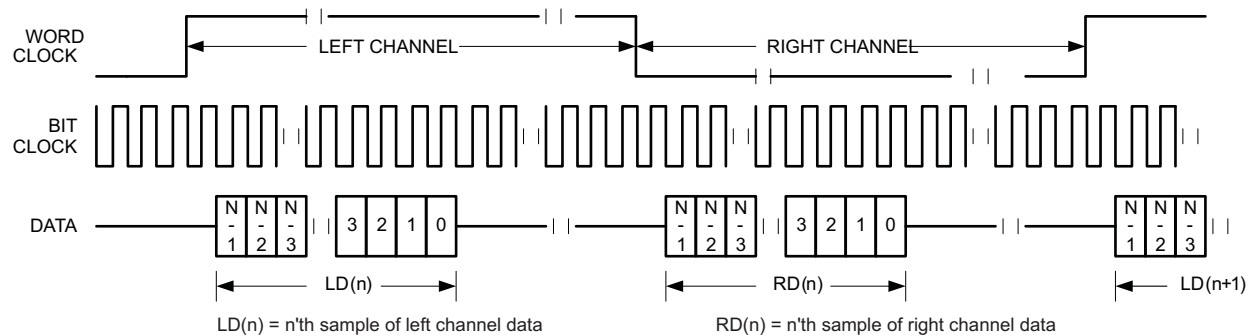

**Figure 27. Timing Diagram for Light-Left Mode with Offset = 1**

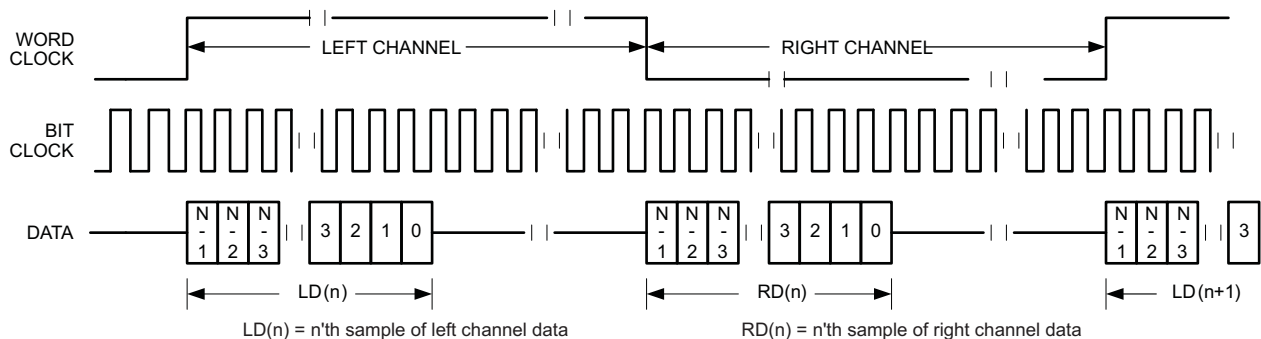

**Figure 28. Timing Diagram for Left-Justified Mode with Offset = 0 and Inverted Bit Clock**

For left-justified mode, the number of bit-clcks per frame should be greater than twice the programmed word-length of the data. Also, the programmed offset value should be less than the number of bit-clcks per frame by at least the programmed word-length of the data.

## Device Functional Modes (continued)

### 9.4.1.3 I<sup>2</sup>S Mode

Audio Serial Interface 1 can be put into I<sup>2</sup>S Mode by programming B0\_P1\_R1\_D[7:5] = 000 and B0\_P1\_R2\_D[7:5] = 000. Audio Serial Interface 2 can be put into I<sup>2</sup>S Mode by programming B0\_P1\_R21\_D[7:5] = 000 and B0\_P1\_R22\_D[7:5] = 000. In I<sup>2</sup>S mode, the MSB of the left channel is valid on the second rising edge of the bit clock after the falling edge of the word clock. Similarly the MSB of the right channel is valid on the second rising edge of the bit clock after the rising edge of the word clock.

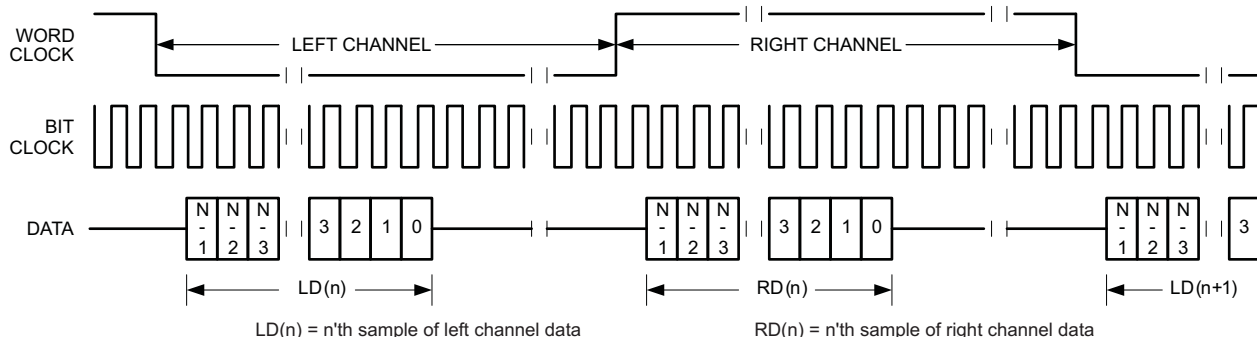

Figure 29. Timing Diagram for I<sup>2</sup>S Mode

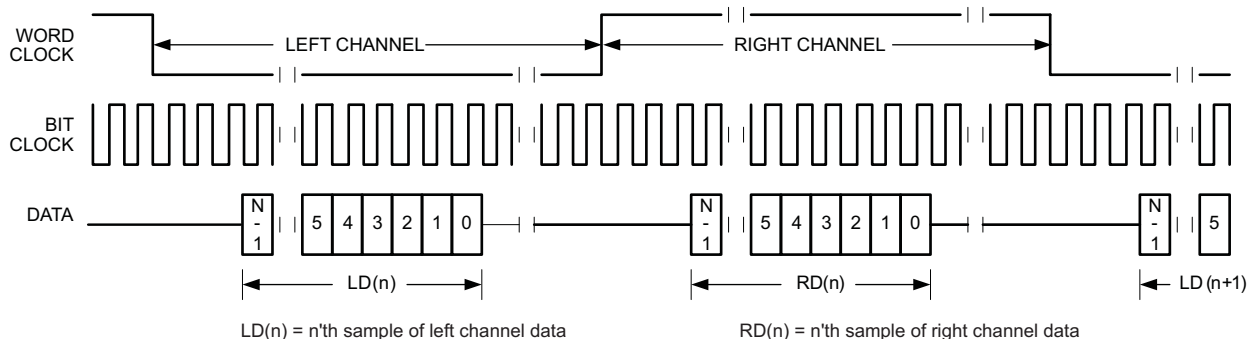

Figure 30. Timing Diagram for I<sup>2</sup>S Mode with Offset = 2

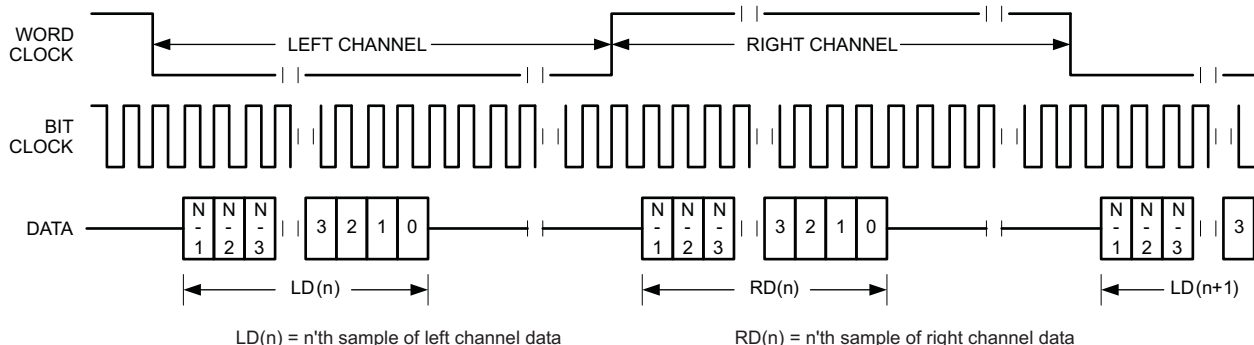

Figure 31. Timing Diagram for I<sup>2</sup>S Mode with Offset = 0 and Inverted Bit Clock

For I<sup>2</sup>S mode, the number of bit-clcks per channel should be greater than or equal to the programmed word-length of the data. Also the programmed offset value should be less than the number of bit-clcks per frame by at least the programmed word-length of the data.

## Device Functional Modes (continued)

### 9.4.1.4 DSP Mode

Audio Serial Interface 1 can be put into DSP Mode by programming  $B0\_P1\_R1\_D[7:5] = 001$  and  $B0\_P1\_R2\_D[7:5] = 001$ . Audio Serial Interface 2 can be put into DSP Mode by programming  $B0\_P1\_R21\_D[7:5] = 001$  and  $B0\_P1\_R22\_D[7:5] = 001$ . In DSP mode, the rising edge of the word clock starts the data transfer with the left channel data first and immediately followed by the right channel data. Each data bit is valid on the falling edge of the bit clock.

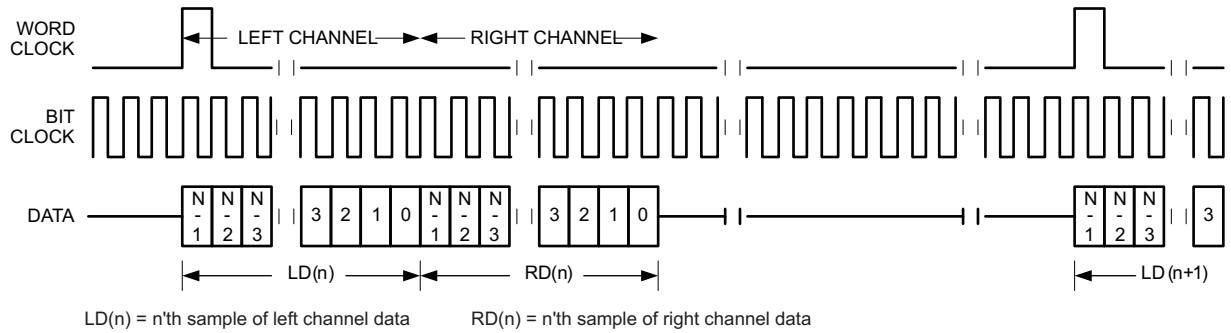

Figure 32. Timing Diagram for DSP Mode

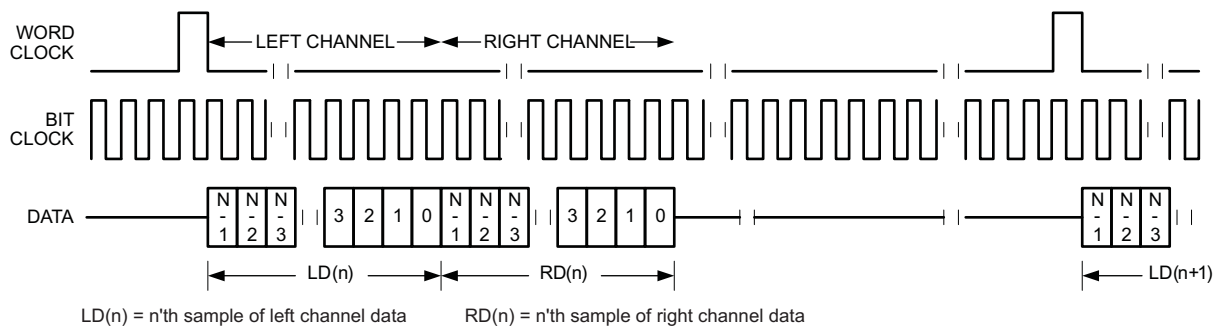

Figure 33. Timing Diagram for DSP Mode with Offset=1

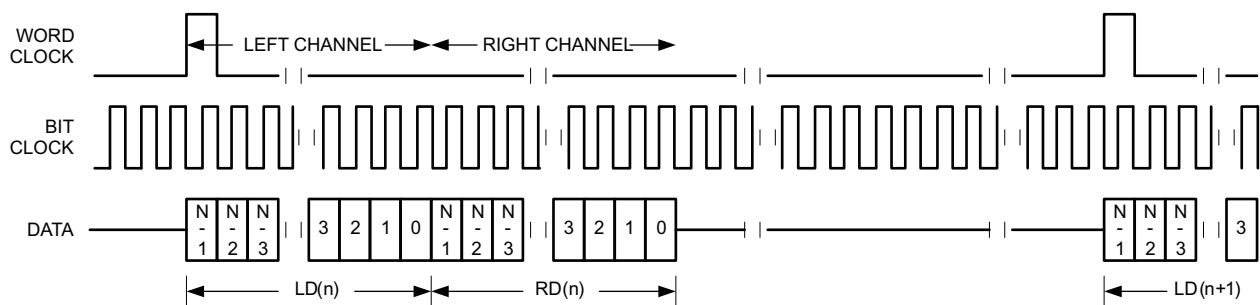

Figure 34. Timing Diagram for DSP Mode with Offset=0 and Inverted Bit Clock

For DSP mode, the number of bit-clcks per frame should be greater than twice the programmed word-length of the data. Also the programmed offset value should be less than the number of bit-clcks per frame by at least the programmed word-length of the data.

## Device Functional Modes (continued)

### 9.4.2 TDM Mode

Time-division multiplexing (TDM) allows two or more devices to share a common DIN connection and a common DOUT connection. Using TDM mode, all devices transmit their DOUT data in user-specified sub-frames within one WCLK period. When one device transmits its DOUT information, the other devices place their DOUT terminals in a high impedance tri-state mode.

TDM mode is useable with I<sup>2</sup>S, LJF, RJF, and DSP interface modes. Refer to the respective sections for a description of how to set the TAS2555 device into those modes.

Use Register B0\_P1\_R3 for ASI1 and B0\_P1\_R23 for ASI2 to set the clock cycle offset from WCLK to the MSB. Each data bit is valid on the falling edge of the bit clock. Set Register B0\_P1\_R1\_D[0] = 1 for ASI1 and B0\_P1\_R21\_D[0] = 1 to force DOUT into tri-state when it is not transmitting data. This allows DOUT terminals from multiple TAS2555 devices to share a common wire to the host.

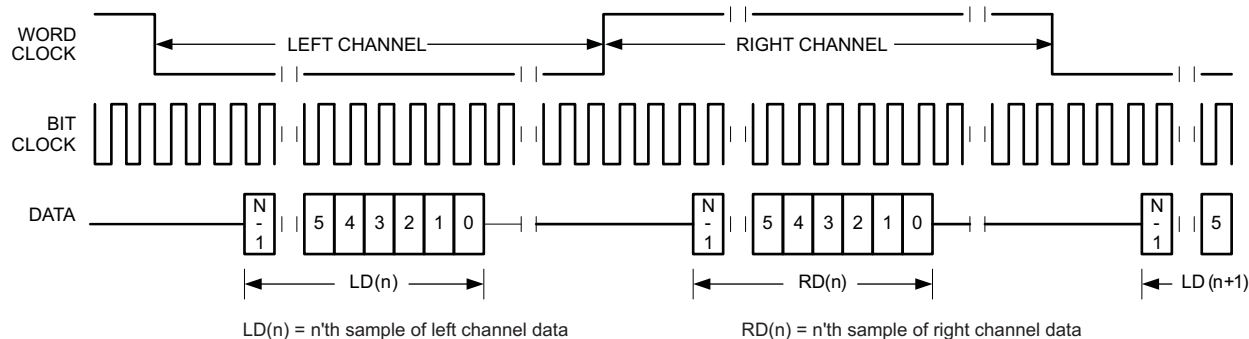

Figure 35. Timing Diagram for I<sup>2</sup>S in TDM Mode with Offset=2

For TDM mode, the number of bit-clocks per frame should be less than the programmed word-length of the data. Also the programmed offset value should be less than the number of bit-clocks per frame by at least the programmed word-length of the data.

### 9.4.3 Device Digital Processing Modes

The TAS2555 DSP can be initialized into one of three modes.

#### 9.4.3.1 ROM Mode 1

ROM mode 1 provides the quickest initialization from the TAS2555 initial power up and is the lowest power mode. This mode can be used to play a known power up audio sequence before the rest of the audio system software is loaded. The mode provides fault protection, brownout protection volume control, and class-H controller. With minimal additional configuration the EQ and Battery Guard can be enabled. The speaker protection algorithm is not running in this mode and the I/V sense ADC are powered down to minimize power consumption. The PLL can be disabled for even lower power consumption if the MCLK supplied is at least 12.288MHz for any fs which is multiple or sub-multiple of 48kHz, or 11.2896MHz for fs of 44.1kHz. This mode is set by writing B)\_P0\_R34[7:0]=0x21 before powering up the DSP B0\_P0\_R4[7]. This mode should be used to characterize the electrical performance on the TAS2555 device without any influence from the protection algorithm present in other modes.

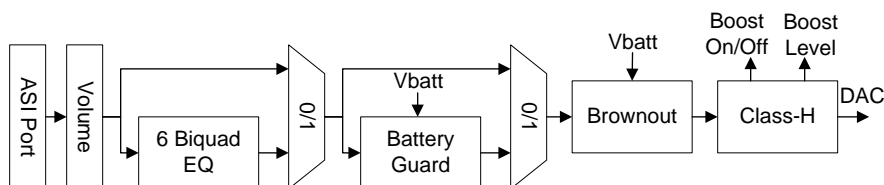
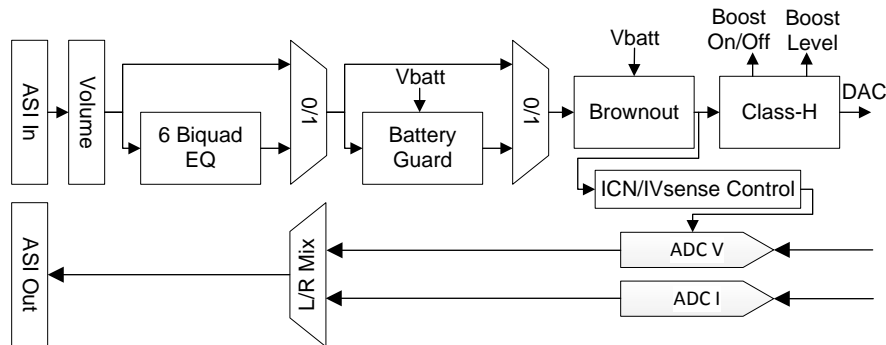

Figure 36. ROM Mode 1 Processing Block Diagram

## Device Functional Modes (continued)

### 9.4.3.2 ROM Mode 2

ROM mode 2 is similar to ROM mode 1 except the I/V sense ADCs are powered up and the data is routed back on the L/R return channels of the ASI port. This mode can be used to return the I/V data to the host and perform alternate computations on the speaker I/V measurements. This mode is set by writing `B0_P0_R34[7:0]=0x22` before powering up the DSP `B0_P0_R4[7]`.



**Figure 37. ROM Mode 1 Processing Block Diagram**

### 9.4.3.3 SmartAmp Mode

SmartAmp Mode is used to run the TI SmartAmp algorithm on the built in DSP. This mode involves loading larger output files generated from the [PurePath™ Console 3 Software TAS2555 Application](#). The generated files contain the speaker models, equalization, and additional configuration parameters in a format to load over the I<sup>2</sup>C or SPI interface. TI's SmartAmp provides Thermal and Excursion protection using initial speaker models and the current and voltage feedback to determine exact coil temperature and update the initial model due to variations in speaker and ambient conditions. More information about this mode can be found in the [PurePath™ Console 3 Software TAS2555 Application](#).

### 9.4.4 Low Power Sleep Mode

The device has a low power sleep mode option to reduce the power consumption on analog supplies (AVDD and VBAT). There are two lower power modes and the choice depends on AVDD supply. First, if the AVDD supply does not drop below the minimum specified voltage, the lowest power mode can be activated by performing a software reset `B0_P0_R1[0]=1`, waiting 100us and then writing shutdown POR blocks `B0_P0_R121[7]=1`. To exit the low power sleep mode write `B0_P0_R121[7]=0` to power up the Avdd and Vbat POR. The part ideally can be placed in low power mode by only shutting down the POR blocks. However, due to non-default configurations TI recommends the software reset.

If the AVDD POR must remain enabled an alternate low power mode should be used. To enable the second low power mode write `B0_P0_R4[7:0]=0` and `B0_P0_R5[7:0]=0`.

## 9.5 Programming

### 9.5.1 Code Loading and CRC check

The TI SmartAmp software is loaded into program ram (PRAM) through writes to mapped memory registers. The encrypted binary software is downloaded and decoded on chip. Therefore read-back of the PRAM is disabled. However a 8 bit CRC checksum is provided to the customer to verify the code was correctly written to PRAM error-free. Once the software download is complete the calculated 8-bit CRC checksum can be read from `B0_P0_R32`. If this value matches the checksum supplied with the program the load to PRAM was successful. If new PRAM code is loaded the TAS2555 device should first be software or hardware reset to reset the CRC checksum register to obtain a proper checksum from the new code to be loaded.

## Programming (continued)

The following is an example script used to load the DSP software and verify the CRC checksum.

```
#####
#This script is a demo for downloading the PRAM code and checking CRC checksum
i i2cstd
#mclk expected is 24.576 MHz
#configuring device registers for 8 ohm speaker load
##### DEVICE INIT SEQ START#####
w 98 00 00 #Page-0
w 98 7f 00 #Book-0
w 98 01 01 #Software reset
d 1 # wait 100us time for OTP-One Time Programmable memory values to be transferred to device

##### INIT SECTION START
w 98 7f 64 # book 100
w 98 46 01 # IRAM boot
w 98 7f 00 # book 0
##### INIT SECTION END

##### DSP PROG SETTING START
w 98 7f 64
w 98 00 01
#add writes for download to PRAM here
w 98 00 00
w 98 7f 00
##### DSP PROG SETTING END

##### DEVICE INIT SEQ END #####

r 98 20 1 # reading the CRC checksum for the PRAM download , if read = CRC checksum provided to
customer => PRAM download success

##### CHANNEL POWER UP #####
w 98 05 A3 # Power up Analog Blocks
w 98 04 B8 # Power up DSP and clock dividers
w 98 07 00 # Unmute Analog Blocks
w 98 7f 64 # switch to book100
w 98 07 00 # Soft stepped unmute of audio playback
#####

##### DSP coeff update START
# d 1
# DSP filter coefficient update if required
##### DSP coeff update END

#####device powered up and running#####

##### CHANNEL POWER DOWN #####
w 98 07 01 # Soft stepped mute of audio playback
d 10 # wait for DSP to mute classD after soft step down of audio
# instead of delay alternatively status flag B120_P15_R120_R121_R122_R123 polling can be done and wait
till R122_D0 = '1'.
w 98 7f 00 # switch to book0
w 98 07 03 # Mute Analog Blocks
w 98 04 20 # Power down DSP and clock dividers (except Ndivider)
w 98 05 00 # Power down Analog Blocks
w 98 00 00 # NOP
w 98 04 00 # Power down Ndivider
#####
#optional(ending the script in B0_P0)
w 98 00 00 # page 0
w 98 7f 00 # book 0
#####
```

## Programming (continued)

### 9.5.2 Device Power Up, Power Down, Mute and Un-mute Sequence

The following code example provide the correct sequence to power up the device, unmute and mute, and provide a clean power-down. The [PurePath™ Console 3 Software TAS2555 Application](#) software will create output files with these commands. The following is a example of powering up the part in DSP Mode 2 with proper sequencing.

```

Example script (ROM Mode 2):
#####
i i2cstd
#mclk expected is 24.576 MHz
#configuring device registers for 8 ohm speaker load
#####
w 98 00 00 #Page-0
w 98 7f 00 #Book-0
w 98 01 01 #Software reset
d 1      # wait 100us time for OTP-One Time Programmable memory values to be transferred to device

##### DSP PROG SETTING START
w 98 22 22 # use default coefficients and operate DSP in rom mode 2
##### DSP PROG SETTING END

#####      DEVICE INIT SEQ END #####

#####      CHANNEL POWER UP      #####
w 98 05 A3 # Power up Analog Blocks
w 98 04 B8 # Power up DSP and clock dividers
w 98 07 00 # Unmute Analog Blocks
w 98 7f 64 # switch to book100
w 98 07 00 # Soft stepped unmute of audio playback
#####

##### DSP coeff update START
# d 1
# DSP filter coefficient update if required
##### DSP coeff update END

b #####device powered up and running#####

#####      CHANNEL POWER DOWN #####
w 98 07 01 # Soft stepped mute of audio playback
d 10      # wait for DSP to mute classD after soft step down of audio
# instead of delay alternatively status flag B120_P15_R120_R121_R122_R123 polling can be done and wait
till R122_D0 = '1'.
w 98 7f 00 # switch to book0
w 98 07 03 # Mute Analog Blocks
w 98 04 20 # Power down DSP and clock dividers (except Ndivider)
w 98 05 00 # Power down Analog Blocks
w 98 00 00 # NOP
w 98 04 00 # Power down Ndivider
#####
#optional(ending the script in B0_P0)
w 98 00 00 # page 0
w 98 7f 00 # book 0
#####

```

## 10 Application and Implementation

### NOTE

Information in the following applications sections is not part of the TI component specification, and TI does not warrant its accuracy or completeness. TI's customers are responsible for determining suitability of components for their purposes. Customers should validate and test their design implementation to confirm system functionality.

### 10.1 Application Information

The TAS2555 device is a digital or analog input high efficiency Class-D audio power amplifier with advanced battery current management and an integrated Class-H boost converter. In auto passthrough mode, the Class-H boost converter generates the Class-D amplifier supply rail. During low Class-D output power, the boost improves efficiency by deactivating and connecting VBAT directly to the Class-D amplifier supply. When high power audio is required, the boost quickly activates to provide louder audio than a stand-alone amplifier connected directly to the battery. To enable load monitoring, the TAS2555 device constantly measures the current and voltage across the load and provides a digital stream of this information back to a processor.

### 10.2 Typical Applications

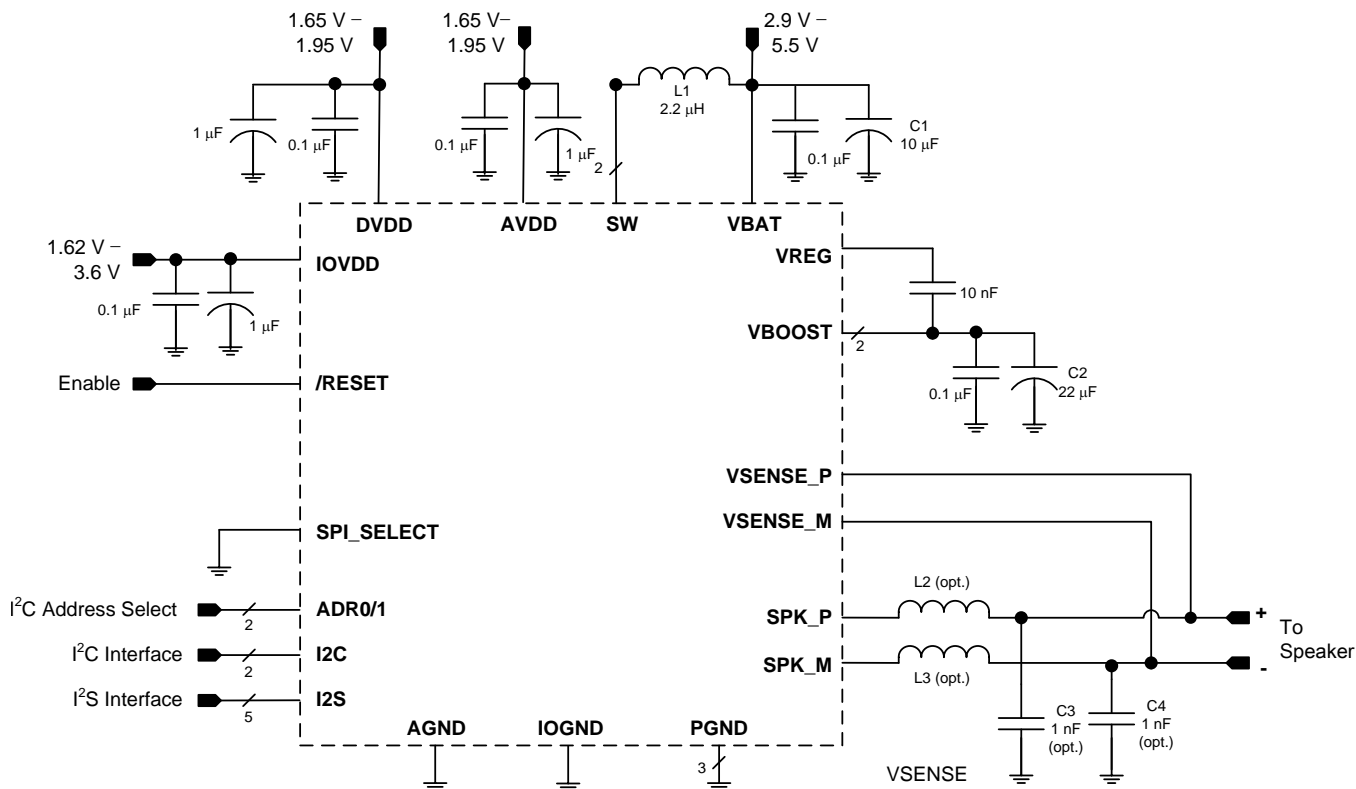

Figure 38. Typical Application - Digital Audio Input

## Typical Applications (continued)

**Table 4. Recommended External Components**

COMPONENT	DESCRIPTION	SPECIFICATION	MIN	TYP	MAX	UNIT
L1	Boost Converter Inductor	Inductance, 20% Tolerance	1	2.2		μH
		Saturation Current		3.1		A
L2, L3	EMI Filter Inductors (optional). These are not recommended as it degrades THD+N performance. The TAS2555 device is a filter-less Class-D and does not require these bead inductors.	Impedance at 100MHz		120		Ω
		DC Resistance			0.095	Ω
		DC Current			2	A
		Size		0402		EIA
C1	Boost Converter Input Capacitor	Capacitance, 20% Tolerance	10			μF
C2	Boost Converter Output Capacitor	Type	X5R			
		Capacitance, 20% Tolerance	22		47	μF
		Rated Voltage	16			V
		Capacitance at 8.5 V derating	3.3			μF
C3, C4	EMI Filter Capacitors (optional, must use L2, L3 if C3, C4 used)	Capacitance		1		nF

### 10.2.1 Design Requirements

For this design example, use the parameters shown in [Table 5](#).

**Table 5. Design Parameters**

DESIGN PARAMETER	EXAMPLE VALUE
Audio Input	Digital Audio, I <sup>2</sup> S
Current and Voltage Data Stream	Digital Audio, I <sup>2</sup> S
Mono or Stereo Configuration	Mono
Max Output Power at 1% THD+N	3.8 W

#### 10.2.1.1 Detailed Design Procedure

##### 10.2.1.1.1 Mono/Stereo Configuration

In this application, the device is assumed to be operating in mono mode. See [General I<sup>2</sup>C Operation](#) for information on changing the I<sup>2</sup>C address of the TAS2555 device to support stereo operation. Mono or stereo configuration does not impact the device performance.

##### 10.2.1.1.2 Boost Converter Passive Devices

The boost converter requires three passive devices that are labeled L1, C1 and C2 in [Figure 38](#) and whose specifications are provided in [Table 4](#). These specifications are based on the design of the TAS2555 and are necessary to meet the performance targets of the device. In particular, L1 should not be allowed to enter in the current saturation region. The saturation current for L1 should be > ILIM to deliver Class-D peak power.

Additionally, the ratio of L1/C2 (the derated value of C2 at 8.5 V should be used in this ratio) has to be lesser than 1/3 for boost stability. This 1/3 ratio should be maintained including the worst case variation of L1 and C2. To satisfy sufficient energy transfer, L1 must be ≥ 1μH at the boost switching frequency (~1.7 MHz). Using a 1μH will have more boost ripple than a 2.2μH but the PSRR should minimize the effect from the additional ripple. Finally, the minimum C2 (derated value at 8.5 V) should be > 3.3μF for Class-D power delivery specification.

##### 10.2.1.1.3 EMI Passive Devices

The TAS2555 device supports edge-rate control to minimize EMI, but the system designer may want to include passive devices on the Class-D output devices. These passive devices that are labeled L2, L3, C3 and C4 in [Figure 38](#) and their recommended specifications are provided in [Table 4](#). If C3 and C4 are used, they must be placed after L2 and L3 respectively to maintain the stability of the output stage.

#### 10.2.1.1.4 Miscellaneous Passive Devices

- VREG Capacitor: Must be 10 nF to meet boost and Class-D power delivery and efficiency specs.

#### 10.2.2 Application Performance Plots

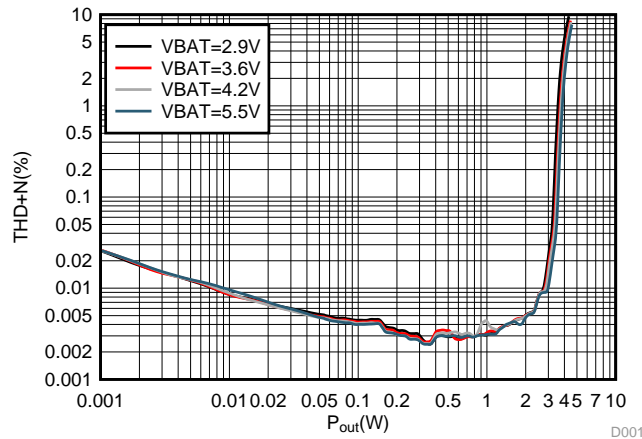

Freq = 1kHz VBAT = 3.6 V, AVDD = IOVDD = 1.8 V,  $\overline{\text{RESET}} = \text{IOVDD}$ ,  $R_L = 8 \Omega + 33 \mu\text{H}$ , I<sup>2</sup>S digital input, ROM mode 1

Figure 39. THD+N vs Output Power (8 Ω) for Digital Input

### 10.3 Initialization Set Up

To configure the TAS2555 device, follow these steps.

1. Bring-up the power supplies as in [Power Supply Sequencing](#).
2. Set the /RESET terminal to HIGH.
3. Follow the software sequence in section [Device Power Up, Power Down, Mute and Un-mute Sequence](#)

## 11 Power Supply Recommendations

### 11.1 Power Supplies

The TAS2555 device requires four power supplies:

- Boost Input (terminal: VBAT)
  - Voltage: 2.9 V to 5.5 V
  - Max Current: 5 A for ILIM = 3.0 A (default)
- Analog Supply (terminal: AVDD)
  - Voltage: 1.65 V to 1.95 V
  - Max Current: 30 mA
- Digital Supply (terminal: DVDD)
  - Voltage: 1.65 V to 1.95 V
  - Max Current: 40 mA
- Digital I/O Supply (terminal: IOVDD)
  - Voltage: 1.62 V to 3.6 V
  - Max Current: 5 mA

The decoupling capacitors for the power supplies should be placed close to the device terminals. For VBAT, IOVDD, DVDD and AVDD, a small decoupling capacitor of 0.1  $\mu$ F should be placed close to the device terminals. Refer to for the schematic.

### 11.2 Power Supply Sequencing

The following power sequence should be followed for power up and power down. If the recommended sequence is not followed there can be large current in device due to faults in level shifters and diodes becoming forward biased. The  $T_{\text{delay}}$  between power supplies should be large enough for the power rails to settle.

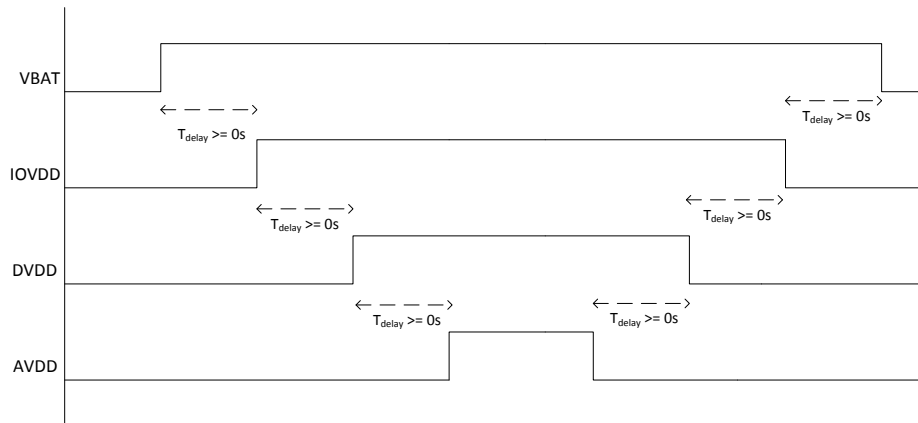

**Figure 40. Power Supply Sequence for Power-Up and Power-Down**

When the supplies have settled, the /RESET terminal can be set HIGH to operate the device. Additionally the /RESET pin can be tied to IOVDD and the internal DVDD POR will perform a reset of the device. After a hardware or software reset additional commands to the device should be delayed for 100 $\mu$ s to allow the OTP to load. The above sequence should be completed before any I<sup>2</sup>C operation.

## 12 Layout

### 12.1 Layout Guidelines

- Place the boost inductor between VBAT and SW close to device terminals with no VIAS between the device terminals and the inductor.
- Place the capacitor between VREG and VBOOST close to device terminals with no VIAS between the device terminals and capacitor.
- Place the capacitor between VBOOST/VBAT and GND close to device terminals with no VIAS between the device terminals and capacitor.
- Do not use VIAS for traces that carry high current. These include the traces for VBOOST, SW, VBAT, PGND and the speaker SPK\_P, SPK\_M.
- Use epoxy filled vias for the interior pads.
- Connect VSENSE+, VSENSE- as close as possible to the speaker.
  - VSENSE+, VSENSE- should be connected between the EMI ferrite and the speaker if EMI ferrites are used on SPK\_P, SPK\_M.
- If the analog inputs, IN\_M and IN\_P, are:
  - used, analog input traces should be routed symmetrically for true differential performance.
  - used, do not run analog input traces parallel to digital lines.
  - used, they should be ac coupled.
  - not used, they should be grounded.
- Use a ground plane with multiple vias for each terminal to create a low-impedance connection to GND for minimum ground noise.
- Use supply decoupling capacitors as shown in [Figure 38](#) and described in [Power Supply Recommendations](#).
- Place EMI ferrites, if used, close to the device.

## 12.2 Layout Example

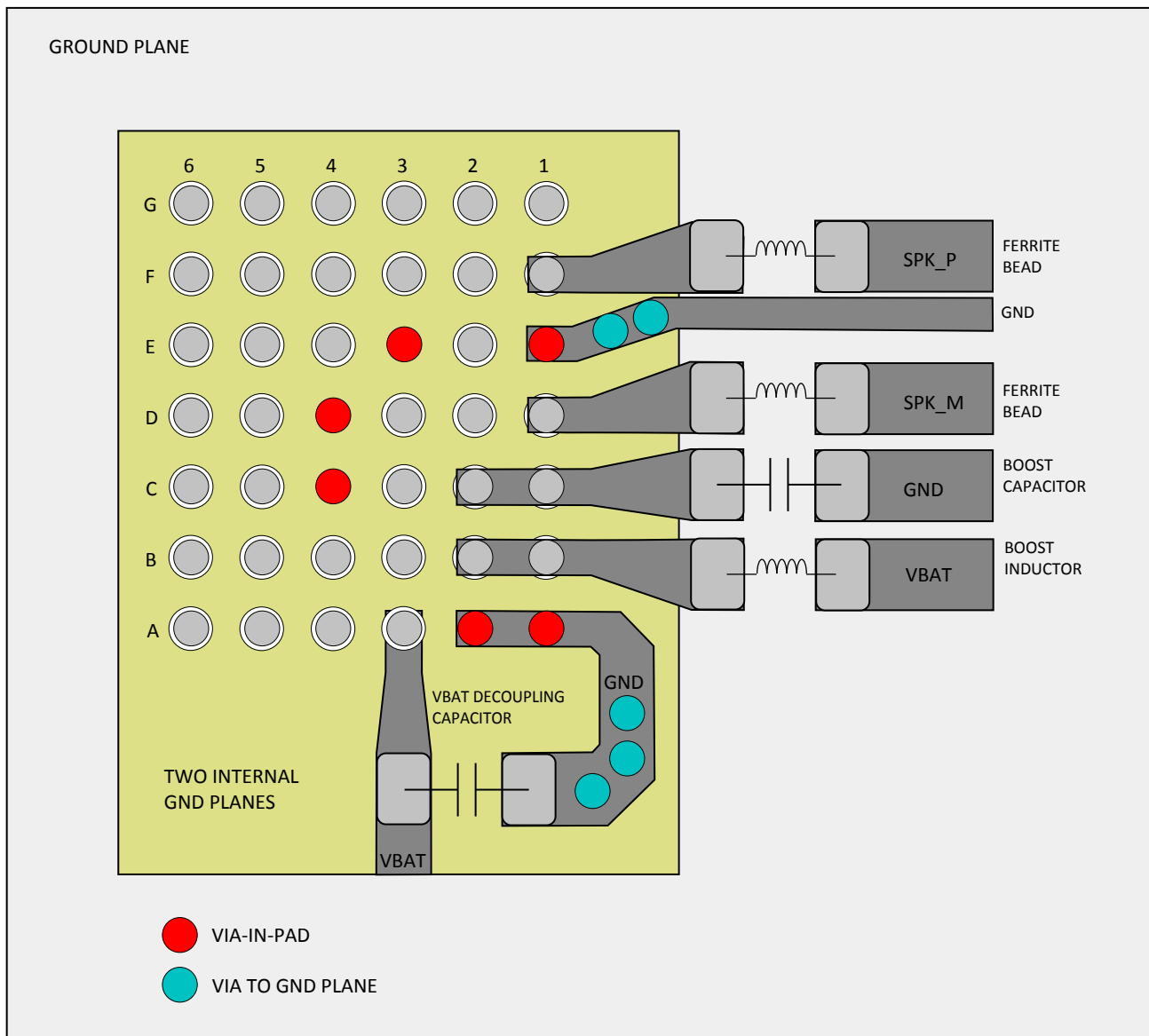

Figure 41. TAS2555 Board Layout

## 13 Register Map

See the General I<sup>2</sup>C Operation section for more details on addressing. Register settings should be set based on the files generated from the PPC3 GUI. Because the TAS2555 device is a complex system including the internal software, changes made in the TAS2555 registers not known in the PPC3 generated configurations can result in the speaker protection not operating correctly. Changes should be made from within [PurePath™ Console 3 Software TAS2555 Application](#) instead of manually changing registers when possible. New configuration files can be generated from PPC3 to prevent invalid configurations.

### 13.1 Register Map Summary

**Table 6. Summary of Register Map**

Decimal			Hex			DESCRIPTION
BOOK NO.	PAGE NO.	REG. NO.	BOOK NO.	PAGE NO.	REG. NO.	
0	0	0	0x00	0x00	0x00	Page Select
0	0	1	0x00	0x00	0x01	Software Reset
0	0	2-3	0x00	0x00	0x02-0x03	Reserved
0	0	4	0x00	0x00	0x04	Power Control
0	0	5	0x00	0x00	0x05	Power Control 2
0	0	6	0x00	0x00	0x06	Speaker Control
0	0	7	0x00	0x00	0x07	Mute
0	0	8	0x00	0x00	0x08	Channel Control
0	0	9-31	0x00	0x00	0x09-0x1F	Reserved
0	0	32	0x00	0x00	0x20	CRC Checksum
0	0	33	0x00	0x00	0x21	Checksum Reset
0	0	34	0x00	0x00	0x22	Device DSP Mode
0	0	35-39	0x00	0x00	0x23-0x27	Reserved
0	0	40	0x00	0x00	0x28	Class-D SSM Mode
0	0	41	0x00	0x00	0x29	Reserved
0	0	42	0x00	0x00	0x2A	Digital Playback Control
0	0	43	0x00	0x00	0x2B	Current Limit
0	0	44	0x00	0x00	0x2C	Clock Error Control 1
0	0	45	0x00	0x00	0x2D	Clock Error Control 2
0	0	46	0x00	0x00	0x2E	Clock Error Control 3
0	0	47-99	0x00	0x00	0x2F-0x63	Reserved
0	0	100	0x00	0x00	0x64	Power Up Flag
0	0	101-103	0x00	0x00	0x65-0x67	Reserved
0	0	104	0x00	0x00	0x68	Interrupt Flags DAC & OCP/OTP Sticky
0	0	105-107	0x00	0x00	0x69-0x6B	Reserved
0	0	108	0x00	0x00	0x6C	DSP Interrupt Output Sticky
0	0	109-120	0x00	0x00	0x6D-0x78	Reserved
0	0	121	0x00	0x00	0x79	Power Modes
0	0	122-126	0x00	0x00	0x7A-0x7E	Reserved
0	0	127	0x00	0x00	0x7F	Book Selection
0	1	0	0x00	0x01	0x00	Page Select

**Register Map Summary (continued)**
**Table 6. Summary of Register Map (continued)**

Decimal			Hex			DESCRIPTION
BOOK NO.	PAGE NO.	REG. NO.	BOOK NO.	PAGE NO.	REG. NO.	
0	1	1	0x00	0x01	0x01	ASI1 DAC Format
0	1	2	0x00	0x01	0x02	ASI1 ADC Format
0	1	3	0x00	0x01	0x03	ASI1 Offset
0	1	4-6	0x00	0x01	0x04-0x06	Reserved
0	1	7	0x00	0x01	0x07	ASI1 ADC Path
0	1	8	0x00	0x01	0x08	ASI1 DAC BCLK
0	1	9	0x00	0x01	0x09	ASI1 DAC WCLK
0	1	10	0x00	0x01	0x0A	ASI1 ADC BCLK
0	1	11	0x00	0x01	0x0B	ASI1 ADC WCLK
0	1	12	0x00	0x01	0x0C	ASI1 DIN/DOOUT MUX
0	1	13	0x00	0x01	0x0D	ASI1 BDIV Clock Select
0	1	14	0x00	0x01	0x0E	ASI1 BDIV Clock Ratio
0	1	15	0x00	0x01	0x0F	ASI1 WDIV Clock Ratio
0	1	16	0x00	0x01	0x10	ASI1 DAC Clock Output
0	1	17	0x00	0x01	0x11	ASI1 ADC Clock Output
0	1	18-20	0x00	0x01	0x12-0x14	Reserved
0	1	21	0x00	0x01	0x15	ASI2 DAC Format
0	1	22	0x00	0x01	0x16	ASI2 ADC Format
0	1	23	0x00	0x01	0x17	ASI2 Offset
0	1	24-26	0x00	0x01	0x18-0x1A	Reserved
0	1	27	0x00	0x01	0x1B	ASI2 ADC Path
0	1	28	0x00	0x01	0x1C	ASI2 DAC BCLK
0	1	29	0x00	0x01	0x1D	ASI2 DAC WCLK
0	1	30	0x00	0x01	0x1E	ASI2 ADC BCLK
0	1	31	0x00	0x01	0x1F	ASI2 ADC WCLK
0	1	32	0x00	0x01	0x20	ASI2 DIN/DOOUT MUX
0	1	33	0x00	0x01	0x21	ASI2 BDIV Clock Select
0	1	34	0x00	0x01	0x22	ASI2 BDIV Clock Ratio
0	1	35	0x00	0x01	0x23	ASI2 WDIV Clock Ratio
0	1	36	0x00	0x01	0x24	ASI2 DAC Clock Output
0	1	37	0x00	0x01	0x25	ASI2 ADC Clock Output
0	1	38-60	0x00	0x01	0x26-0x3C	Reserved
0	1	61	0x00	0x01	0x3D	BCLK1_GPIO1 Pin
0	1	62	0x00	0x01	0x3E	WCLK1_GPIO2 Pin
0	1	63	0x00	0x01	0x3F	DOOUT1_GPIO3 Pin
0	1	64	0x00	0x01	0x40	IRQ_GPIO4 Pin
0	1	65	0x00	0x01	0x41	BCLK2_GPIO5 Pin
0	1	66	0x00	0x01	0x42	WCLK2_GPIO6 Pinb
0	1	67	0x00	0x01	0x43	DOOUT2_GPIO7 Pin
0	1	68	0x00	0x01	0x44	DIN2_GPIO8 Pin
0	1	69	0x00	0x01	0x45	ICC_CLK_GPIO9 Pin

**Register Map Summary (continued)**
**Table 6. Summary of Register Map (continued)**

Decimal			Hex			DESCRIPTION
BOOK NO.	PAGE NO.	REG. NO.	BOOK NO.	PAGE NO.	REG. NO.	
0	1	70	0x00	0x01	0x46	ICC_GPIO10 Pin
0	1	71-76	0x00	0x01	0x47-0x4C	Reserved
0	1	77	0x00	0x01	0x4D	GPI Pin
0	1	78	0x00	0x01	0x4E	Reserved
0	1	79	0x00	0x01	0x4F	GPIO HIZ CTRL1
0	1	80	0x00	0x01	0x50	GPIO HIZ CTRL2
0	1	81	0x00	0x01	0x51	GPIO HIZ CTRL3
0	1	82	0x00	0x01	0x52	GPIO HIZ CTRL4
0	1	83	0x00	0x01	0x53	GPIO HIZ CTRL3
0	1	84-86	0x00	0x01	0x54-0x56	Reserved
0	1	87	0x00	0x01	0x57	GPIO Pin 1
0	1	88	0x00	0x01	0x58	GPIO Pin 2
0	1	89	0x00	0x01	0x59	GPIO Pin 3
0	1	90-107	0x00	0x01	0x5A-0x6B	Reserved
0	1	108	0x00	0x01	0x6C	Interrupt Control 1
0	1	109	0x00	0x01	0x6D	Interrupt Control 2
0	1	110	0x00	0x01	0x6E	Interrupt Control 3
0	1	111	0x00	0x01	0x6F	Interrupt Control 4
0	1	112	0x00	0x01	0x70	Interrupt Control 5
0	1	113	0x00	0x01	0x71	Interrupt Control 6
0	1	114-127	0x00	0x01	0x72-0xFF	Reserved Registers
0	2	0	0x00	0x01	0x00	Page Select Register
0	2	1-5	0x00	0x01	0x01-0x05	Reserved Registers
0	2	6	0x00	0x01	0x06	Ramp Generator Frequency
0	2	7-23	0x00	0x01	0x07x17	Reserved Registers
0	2	24	0x00	0x01	0x18	Inrush Optimization 1
0	2	25	0x00	0x01	0x19	Inrush Optimization 2
0	2	26	0x00	0x01	0x1A	Inrush Optimization 3
0	2	27	0x00	0x01	0x1B	Inrush Optimization 4
0	2	28-127	0x00	0x01	0x1C-0x7F	Reserved Registers
100	0	0	0x64	0x00	0x00	Page Select Register
100	0	1	0x64	0x00	0x01	DAC Interpolation
100	0	2	0x64	0x00	0x02	ADC interpolation Register
100	0	3-6	0x64	0x00	0x03-0x06	Reserved Registers
100	0	7	0x64	0x00	0x07	DSP Mute Register
100	0	8-15	0x64	0x00	0x0F	Reserved Registers
100	0	16	0x64	0x00	0x10	Interrupt 1 DSP
100	0	17	0x64	0x00	0x11	Interrupt 2 DSP
100	0	18	0x64	0x00	0x12	Condition 1 DSP

**Register Map Summary (continued)**
**Table 6. Summary of Register Map (continued)**

Decimal			Hex			DESCRIPTION
BOOK NO.	PAGE NO.	REG. NO.	BOOK NO.	PAGE NO.	REG. NO.	
100	0	19	0x64	0x00	0x13	Condition 2 DSP
100	0	20	0x64	0x00	0x14	ISR and COND Control
100	0	21	0x64	0x00	0x15	DSP Control Register
100	0	22-26	0x64	0x00	0x16-0x1A	Reserved Register
100	0	27	0x64	0x00	0x1B	PLL CLKIN Divider
100	0	28	0x64	0x00	0x1C	PLL J-VAL Divider
100	0	29	0x64	0x00	0x1D	PLL D-VAL Divider 2
100	0	30	0x64	0x00	0x1E	D-VAL Divider 1
100	0	31	0x64	0x00	0x1F	DSP Clock
100	0	32	0x64	0x00	0x20	N-VAL Divider
100	0	33	0x64	0x00	0x21	MDAC-VAL Divider
100	0	34	0x64	0x00	0x22	MADC-VAL Divider
100	0	35-37	0x64	0x00	0x23-0x25	Reserved Register
100	0	38	0x64	0x00	0x26	Charge-pump Clock
100	0	39	0x64	0x00	0x27	Boost Clock
100	0	40	0x64	0x00	0x28	Ramp Clock 1
100	0	41-42	0x64	0x00	0x29-0x2A	Reserved Register
100	0	43	0x64	0x00	0x2B	Ramp Clock 2
100	0	44	0x64	0x00	0x2C	Ramp Clock 3
100	0	45-126	0x64	0x00	0x2D-0x7E	Reserved Register
100	0	127	0x64	0x00	0x7F	Book Selection

**13.2 Book 0 Page 0**
**Book 0 / Page 0 / Register 0: Page Select Register - 0x00 / 0x00 / 0x00 (B0\_P0\_R0)**

BIT	FIELD	READ/ WRITE	RESET VALUE	DESCRIPTION
D7-D0	PAGE	R/W	0000 0000	Page Select Register 0-255: Selects the Register Page for next read or write command. Refer Table for details.

**Book 0 / Page 0 / Register 1: Software Reset Register - 0x00 / 0x00 / 0x01 (B0\_P0\_R1)**

BIT	FIELD	READ/ WRITE	RESET VALUE	DESCRIPTION
D7-D1	RESERVED	R/W	0000 000	Reserved. Write only reset values.
D0	RESET	R/W	0	Self-clearing software reset bit. Set to value of 1 to reset. 0: Don't care 1: Self clearing software reset

**Book 0 / Page 0 / Register 2-3: Reserved Registers - 0x00 / 0x00 / 0x02-0x03 (B0\_P0\_R2-3)**

BIT	FIELD	READ/ WRITE	RESET VALUE	DESCRIPTION
D7-D0	RESERVED	R	xxxx xxxx	Reserved.

**Book 0 / Page 0 / Register 4: Power Control Register - 0x00 / 0x00 / 0x04 (B0\_P0\_R4)**

BIT	FIELD	READ/ WRITE	RESET VALUE	DESCRIPTION
D7	PCR_DSP	R/W	0	DSP is 0: powered-down 1: powered-up
D6	PCR_PLL	R/W	0	0: PLL is 0: powered-down 1: powered-up
D5	PCR_N	R/W	0	0: N divider is 0: powered-down 1: powered-up
D4	PCR_MDAC	R/W	0	0: MDAC divider is 0: powered-down 1: powered-up
D3	PCR_MADC	R/W	0	0: MADC divider is 0: powered-down 1: powered-up
D2-D1	RESERVED	R/W	0	Reserved. Write only reset values.
D0	PCR_SD	R/W	0	0: Device software shutdown is 0: powered-down 1: powered-up (all blocks shut-down and goes into low power mode)

**Book 0 / Page 0 / Register 5: Power Control Register 2 - 0x00 / 0x00 / 0x05 (B0\_P0\_R5)**

BIT	FIELD	READ/ WRITE	RESET VALUE	DESCRIPTION
D7	PCR_CLASSD	R/W	0	Class-D outputs are 0: Disabled 1: Enabled
D6	RESERVED	R/W	0	Reserved. Write only reset values.
D5	PCR_BOOST	R/W	0	0: Boost is 0: Disabled 1: Enabled
D4-D2	RESERVED	R/W	000	Reserved. Write only reset values.
D1	PCR_ISNS	R/W	0	0: I-sense ADC is 0: Disabled 1: Enabled
D0	PCR_VSNS	R/W	0	0: V-sense ADC is 0: Disabled 1: Enabled

**Book 0 / Page 0 / Register 6: Speaker Control Register - 0x00 / 0x00 / 0x06 (B0\_P0\_R6)**

BIT	FIELD	READ/ WRITE	RESET VALUE	DESCRIPTION
D7	RESERVED	R/W	0	Reserved. Write only reset values.
D6-D3	DAC_GAIN	R/W	1111	DAC Playback channel gain (outside DSP) is 0000: 0dB 0001: 1dB 0010: 2dB ... 1110: 14dB 1111: 15dB
D2-D0	DAC_EDGE	R/W	100	Class-D output edge rate control is 000: Reserved 001: Reserved 010: 29ns 011: 25ns 100: 14ns 101: 13ns 110: 12ns 111: 11ns

**Book 0 / Page 0 / Register 7: Mute Register - 0x00 / 0x00 / 0x07 (B0\_P0\_R7)**

BIT	FIELD	READ/ WRITE	RESET VALUE	DESCRIPTION
D7-D5	RESERVED	R/W	000	Reserved. Write only reset values.
D4-D2	RESERVED	R/W	000	Reserved. Write only reset values.
D1	MUTE_ISNS	R/W	1	0: Un-mute I-sense 1: Mute I-sense
D0	MUTE_SPK	R/W	1	0: Un-mute Class-D 1: Mute Class-D

**Book 0 / Page 0 / Register 8: Channel Control Register - 0x00 / 0x00 / 0x08 (B0\_P0\_R8)**

BIT	FIELD	READ/ WRITE	RESET VALUE	DESCRIPTION
D7-D3	RESERVED	R/W	00000	Reserved. Write only reset values.
D2-D1	SENSE_GAIN	R/W	00	IVsense gain setting is 00: Isense channel full-scale output corresponds to 1.25A and Vsense channel full-scale output corresponds to 8.5V (recommended to use for 8-ohm ) 01: Isense channel full-scale output corresponds to 1.48A and Vsense channel full-scale output corresponds to 8.5V (recommended to use for 6-ohm load case) 10: Isense channel full-scale output corresponds to 1.76A and Vsense channel full-scale output corresponds to 8.5V (recommended to use for 4-ohm load case) 11: Reserved
D0	VSENSE_ADCM	R/W	0	Vsense ADC is used for 0: sensing Class-D output voltage 1: analog input

**Book 0 / Page 0 / Register 9-31: Reserved Registers - 0x00 / 0x00 / 0x09-0x1F (B0\_P0\_R9-31)**

BIT	FIELD	READ/ WRITE	RESET VALUE	DESCRIPTION
D7-D0	RESERVED	R	xxxx xxxx	Reserved

**Book 0 / Page 0 / Register 32: CRC Checksum Register - 0x00 / 0x00 / 0x20 (B0\_P0\_R32)**

BIT	FIELD	READ/ WRITE	RESET VALUE	DESCRIPTION
D7-D0	CRC_CHECKSUM	R	xxxx xxxx	CRC checksum of all encrypted PRAM content downloaded to device since checksum reset

**Book 0 / Page 0 / Register 33: Checksum Reset Register - 0x00 / 0x00 / 0x21 (B0\_P0\_R33)**

BIT	FIELD	READ/ WRITE	RESET VALUE	DESCRIPTION
D7-D1	RESERVED	R/W	000 0000	Reserved. Write only reset values.
D0	CRC_RESET	R/W	0	PRAM Checksum 0: PRAM download check-sum is not reset. 1: PRAM download check-sum is reset. (This is recommended to be done before PRAM code download so that after download the above checksum value can be read to confirm download process has any error )

**Book 0 / Page 0 / Register 34: Device DSP Mode Register - 0x00 / 0x00 / 0x22 (B0\_P0\_R34)**

BIT	FIELD	READ/ WRITE	RESET VALUE	DESCRIPTION
D7-D6	RESERVED	R/W	00	Reserved. Write only reset values.
D5	MODE_COEFF	R/W	1	Default coefficients are 0: from host. Host needs to download coefficients into device. 1: from internal ROM. Default coefficients for ROM modes.
D4-D2	RESERVED	R/W	000	Reserved. Write only reset values.

**Book 0 / Page 0 / Register 34: Device DSP Mode Register - 0x00 / 0x00 / 0x22 (B0\_P0\_R34) (continued)**

BIT	FIELD	READ/ WRITE	RESET VALUE	DESCRIPTION
D1-D0	MODE_DSP	R/W	01	DSP Mode is 00: SmartAmp Mode 01: ROM Mode 1: Digital input playback only 10: ROM Mode 2: Digital input with I/V-sense 11: Reserved

**Book 0 / Page 0 / Register 35-39: Reserved Registers - 0x00 / 0x00 / 0x23-0x27 (B0\_P0\_R35-R39)**

BIT	FIELD	READ/ WRITE	RESET VALUE	DESCRIPTION
D7-D0	RESERVED	R	xxxx xxxx	Reserved

**Book 0 / Page 0 / Register 40: Class-D SSM Mode Register - 0x00 / 0x00 / 0x28 (B0\_P0\_R40)**

BIT	FIELD	READ/ WRITE	RESET VALUE	DESCRIPTION
D7-D1	RESERVED	R/W	000 0000	Reserved. Write only default values.
D0	RAMP_SSM_MODE	R/W	0	Ramp generator Spread Spectrum Mode (SSM) mode of operation is 0: Disabled. 1: Enabled. This is supported only when Class-D RAMP_CLK is generated using on-chip RAMP_CLK generator, which can be configured using B100_P0_R40.

**Book 0 / Page 0 / Register 41: Reserved Registers - 0x00 / 0x00 / 0x29 (B0\_P0\_R41)**

BIT	FIELD	READ/ WRITE	RESET VALUE	DESCRIPTION
D7-D0	RESERVED	R	xxxx xxxx	Reserved

**Book 0 / Page 0 / Register 42: Digital Playback Control Register - 0x00 / 0x00 / 0x2A (B0\_P0\_R42)**

BIT	FIELD	READ/ WRITE	RESET VALUE	DESCRIPTION
D7-D5	RESERVED	R/W	000	Reserved. Write only reset values.
D4-D3	ASI2_CHANNEL	R/W	0	ASI2 Playback Input 00: ASI2 Left channel is used 01: ASI2 Right channel is used 10: ASI2 (Left+Right)/2 is used 11: ASI2 monoPCM input expected
D2-D1	ASI1_CHANNEL	R/W	0	ASI1 Playback Input 00: ASI1 Left channel is used 01: ASI1 Right channel is used 10: ASI1 (Left+Right)/2 is used 11: ASI1 monoPCM input expected
D0	SOFT_MUTE	R/W	0	Soft Stepping of Mute/Un-Mute is 0: Enabled 1: Disabled

**Book 0 / Page 0 / Register 43: Current Limit Register - 0x00 / 0x00 / 0x2B (B0\_P0\_R43)**

BIT	FIELD	READ/ WRITE	RESET VALUE	DESCRIPTION
D7-D2	RESERVED	R/W	0000 00	Reserved. Write only reset values.
D1-D0	BOOST_ILIMIT	R/W	11	Boost current limit is 00: 1.5A 01: 2.0A 10: 2.5A 11: 3.0A

**Book 0 / Page 0 / Register 44: Clock Error Control 1 Register - 0x00 / 0x00 / 0x2C (B0\_P0\_R44)**

BIT	FIELD	READ/ WRITE	RESET VALUE	DESCRIPTION
D7-D5	RESERVED	R	000	Reserved. Write only reset values.
D4	CLK_ERR1_INPUT	R/W	0	Clock error detection 1 input clock is 0: ASI1 1: ASI2
D3-D2	CLK_ERR2_INPUT	R/W	00	Clock error detection 2 input clock is 00: DAC modulator clock 01: ADC modulator clock 10: PLL clock 11: Reserved
D1	CLK_ERR1_EN	R/W	0	Clock error detection 1 is 0: Disable 1: Enable
D0	CLK_ERR2_EN	R/W	0	Clock error detection 2 is 0: Disable 1: Enable

**Book 0 / Page 0 / Register 45: Clock Error Control 2 Register - 0x00 / 0x00 / 0x2D (B0\_P0\_R45)**

BIT	FIELD	READ/ WRITE	RESET VALUE	DESCRIPTION
D7-D3	RESERVED	R	0001 0	Reserved. Write only reset values.
D2-D0	CLK_ERR1_TO	R/W	111	Clock error detection 1 shutdown timeout. B0_P0_R4[0] will be 1 after shutdown. Program that bit to 0 before powering up the device again. Chip will shutdown if a valid clock is not applied to error detection1 block for 000: 11ms 001: 22ms 010: 44ms 011: 87ms 100: 174ms 101: 350ms 110: 700ms 111: 1.4s

**Book 0 / Page 0 / Register 46: Clock Error Control 3 Register - 0x00 / 0x00 / 0x2E (B0\_P0\_R46)**

BIT	FIELD	READ/ WRITE	RESET VALUE	DESCRIPTION
D7-D3	RESERVED	R	0001 0	Reserved. Write only reset values.
D2-D0	CLK_ERR2_TO	R/W	111	Clock error detection 2 shutdown timeout. B0_P0_R4[0] will be 1 after shutdown. Program that bit to 0 before powering up the device again. Chip will shutdown if a valid clock is not applied to error detection2 block for 000: 11ms 001: 22ms 010: 44ms 011: 87ms 100: 174ms 101: 350ms 110: 700ms 111: 1.4s

**Book 0 / Page 0 / Register 47-99: Reserved Registers - 0x00 / 0x00 / 0x2F-0x63 (B0\_P0\_R47-R99)**

BIT	FIELD	READ/ WRITE	RESET VALUE	DESCRIPTION
D7-D0	RESERVED	R	xxxx xxxx	Reserved

**Book 0 / Page 0 / Register 100: Power Up Flag Register - 0x00 / 0x00 / 0x64 (B0\_P0\_R100)**

BIT	FIELD	READ/ WRITE	RESET VALUE	DESCRIPTION
D7	PWR_DAC	R	0	DAC Power is 0: DAC Powered Down 1: DAC Powered Up
D6	PWR_SPK	R	0	Class D Power is 0: Class D Powered Down 1: Class D Powered Up
D5	PWR_BOOST	R	0	Boost Power is 0: Boost Powered Down 1: Boost Powered Up
D4	BOOST_PT_EN	R	0	Boost Pass-through is 0: Boost Pass-through disable 1: Boost Pass-through enable
D3	PWR_ISENSE	R	0	ISense ADC Power is 0: ISense ADC Powered Down 1: ISense ADC Powered Up
D2	PWR_VSENSE	R	0	VSense ADC Power is 0: VSense ADC Powered Down 1: VSense ADC Powered Up
D1-D0	RESERVED	R	00	Reserved

**Book 0 / Page 0 / Register 101-103: Reserved Registers - 0x00 / 0x00 / 0x65-0x67 (B0\_P0\_R101-R103)**

BIT	FIELD	READ/ WRITE	RESET VALUE	DESCRIPTION
D7-D0	RESERVED	R	xxxx xxxx	Reserved

**Book 0 / Page 0 / Register 104: Interrupt Flags DAC & OCP/OTP Sticky Register - 0x00 / 0x00 / 0x68 (B0\_P0\_R104)**

BIT	FIELD	READ/ WRITE	RESET VALUE	DESCRIPTION
D7	OVER_CURRENT	R	0	SPK Over-current STICKY - Cleared once read is 0: SPK Over-current is not detected 1: SPK Over-current is detected
D6	UNDER_VOLTAGE	R	0	SPK Over-voltage STICKY - Cleared once read is 0: Analog supplies under voltage is not detected 1: Analog supplies under voltage is detected
D5	RESERVED	R	0	Reserved
D4	OVER_TEMP	R	0	Over-temperature STICKY - Cleared once read is 0: Over-temperature is not detected 1: Over-temperature is detected
D3	BROWNOUT	R	0	Brownout STICKY - Cleared once read is 0: Normal supply is present 1: Brownout condition is detected
D2	CLK_PRESENT	R	0	Clock Present STICKY - Cleared once read is 0: Clock is present 1: Clock is lost
D1	SAR_COMPLETE	R	0	SAR complete STICKY - Cleared once read is 0: SAR has not completed 1: SAR complete
D0	RESERVED	R	0	Reserved

**Book 0 / Page 0 / Register 105-107: Reserved Registers - 0x00 / 0x00 / 0x69-0x6B (B0\_P0\_R105-R107)**

BIT	FIELD	READ/ WRITE	RESET VALUE	DESCRIPTION
D7-D0	RESERVED	R	xxxx xxxx	Reserved

**Book 0 / Page 0 / Register 108: DSP Interrupt Output Sticky Register - 0x00 / 0x00 / 0x6C (B0\_P0\_R108)**

BIT	FIELD	READ/ WRITE	RESET VALUE	DESCRIPTION
D7	INT1	R	0	DSP output Interrupt1 Port Output STICKY - Cleared once read
D6	INT2	R	0	DSP output Interrupt2 Port Output STICKY - Cleared once read
D5	INT3	R	0	DSP output Interrupt3 Port Output STICKY - Cleared once read
D4	INT4	R	0	DSP output Interrupt4 Port Output STICKY - Cleared once read
D3-D0	RESERVED	R	0000	Reserved

**Book 0 / Page 0 / Register 109-120: Reserved Registers - 0x00 / 0x00 / 0x6D-0x78 (B0\_P0\_R109-R120)**

BIT	FIELD	READ/ WRITE	RESET VALUE	DESCRIPTION
D7-D0	RESERVED	R	xxxx xxxx	Reserved

**Book 0 / Page 0 / Register 121: Power Modes Register - 0x00 / 0x00 / 0x79 (B0\_P0\_R121)**

BIT	FIELD	READ/ WRITE	RESET VALUE	DESCRIPTION
D7	LOW_POWER_EN	R/W	0	Low-power sleep mode is 0: Disabled 1: Enabled - Set high only when AVDD and VBAT supplies are available in the system.
D6-D0	RESERVED	R/W	000 0000	Reserved. Write only reset values.

**Book 0 / Page 0 / Register 122-126: Reserved Registers - 0x00 / 0x00 / 0x7A-0x7E (B0\_P0\_R122-R126)**

BIT	FIELD	READ/ WRITE	RESET VALUE	DESCRIPTION
D7-D0	RESERVED	R	xxxx xxxx	Reserved

**Book 0 / Page 0 / Register 127: Book Selection Register - 0x00 / 0x00 / 0x7F (B0\_P0\_R127)**

BIT	FIELD	READ/ WRITE	RESET VALUE	DESCRIPTION
D7-D0	BOOK	R/W	0000 0000	0-255: Selects the Register Book for next read or write command.

### 13.3 Book 0 Page 1

**Book 0 / Page 1 / Register 0: Page Select Register - 0x00 / 0x01 / 0x00 (B0\_P1\_R0)**

BIT	FIELD	READ/ WRITE	RESET VALUE	DESCRIPTION
D7-D0	PAGE	R/W	0000 0001	Page Select Register is 0-255: Selects the Register Page for next read or write command. Refer Table for details.

**Book 0 / Page 1 / Register 1: ASI1 DAC Format Register - 0x00 / 0x01 / 0x01 (B0\_P1\_R1)**

BIT	FIELD	READ/ WRITE	RESET VALUE	DESCRIPTION
D7-D5	ASI1D_INTERFACE	R/W	000	ASI1 DAC interface is 000: I2S 001: DSP 010: Right-Justified (RJF). Non-zero values of ASI1_OFFSET1 not supported. 011: Left-Justified (LJF) 100: MonoPCM 101-111: Reserved

**Book 0 / Page 1 / Register 1: ASI1 DAC Format Register - 0x00 / 0x01 / 0x01 (B0\_P1\_R1) (continued)**

BIT	FIELD	READ/ WRITE	RESET VALUE	DESCRIPTION
D4-D3	ASI1D_WORD_LEN	R/W	10	ASI1 DAC word length is 00: 16 bits 01: 20 bits 10: 24 bits 11: 32 bits
D2-D1	RESERVED	R/W	00	Reserved. Write only reset values.
D0	ASI1_TRISTATE	R/W	0	Tri-stating of DOUT1 for the extra ASI1_BCLK cycles after Data Transfer is over for a frame is 0: Disabled 1: Enabled

**Book 0 / Page 1 / Register 2: ASI1 ADC Format Register - 0x00 / 0x01 / 0x02 (B0\_P1\_R2)**

BIT	FIELD	READ/ WRITE	RESET VALUE	DESCRIPTION
D7-D5	ASI1A_INTERFACE	R/W	000	ASI1 ADC Interface (This register control is valid only if D0 = 1) 000: I2S 001: DSP 010: RJF. non-zero values of ASI1_OFFSET1 not supported. 011: LJF 100: MonoPCM 101-111: Reserved
D4-D3	ASI1A_WORD_LEN	R/W	00	ASI1 ADC word length (This register control is valid only if D0 = 1) 00: 16 bits 01: 20 bits 10: 24 bits 11: 32 bits
D2-D1	RESERVED	R/W	00	Reserved. Write only reset values.
D0	ASI1A_USE_DAC	R/W	0	ASI1 ADC uses 0: the same Interface type and word length as DAC side as in B0_P1_R1 1: the Interface type and word length from B0_P1_R2[7:3]

**Book 0 / Page 1 / Register 3: ASI1 Offset Register - 0x00 / 0x00 / 0x03 (B0\_P1\_R3)**

BIT	FIELD	READ/ WRITE	RESET VALUE	DESCRIPTION
D7-D0	ASI1_OFFSET	R/W	0000 0000	ASI1_OFFSET = x ASI1_BCLK's. Offset is measured with respect to WCLK-rising edge in DSP Mode. Offset is not supported for RJF mode 0000 0000: 0 ASI1_BCLK's 0000 0001: 1 ASI1_BCLK's ... 1111 1110: 254 ASI1_BCLK's 1111 1111: 255 ASI1_BCLK's

**Book 0 / Page 1 / Register 4-6: Reserved Registers - 0x00 / 0x01 / 0x04-0x06 (B0\_P1\_R4-6)**

BIT	FIELD	READ/ WRITE	RESET VALUE	DESCRIPTION
D7-D0	RESERVED	R	xxxx xxxx	Reserved.

**Book 0 / Page 1 / Register 7: ASI1 ADC Path Register - 0x00 / 0x01 / 0x07 (B0\_P1\_R7)**

BIT	FIELD	READ/ WRITE	RESET VALUE	DESCRIPTION
D7-D3	RESERVED	R/W	0000 0	Reserved. Write only reset values.

**Book 0 / Page 1 / Register 7: ASI1 ADC Path Register - 0x00 / 0x01 / 0x07 (B0\_P1\_R7) (continued)**

BIT	FIELD	READ/ WRITE	RESET VALUE	DESCRIPTION
D2-D0	ASI1A_PATH	R/W	001	ASI1 ADC path is 000: ASI1_ADC_DATA is disabled. No serial data output from ASI1 001: ASI1_ADC_DATA <Left,Right> = DSP_OUT<Left,Right> 010: Reserved 011: Reserved 100: Reserved 101: ASI1_ADC_DATA<Left,Right> = ASI1_CHANNEL<Left,Right> 110: ASI1_ADC_DATA<L1,R1> = ASI2_CHANNEL<Left,Right> 111: Reserved

**Book 0 / Page 1 / Register 8: ASI1 DAC BCLK Register - 0x00 / 0x01 / 0x08 (B0\_P1\_R8)**

BIT	FIELD	READ/ WRITE	RESET VALUE	DESCRIPTION
D7	RESERVED	R/W	0	Reserved. Write only reset values.
D6-D3	ASI1D_BCLK_PATH	R/W	0000	ASI1_DAC_BCLK input from 0000: GPIO1 (Preferred pin usage) 0001: GPIO2 0010: GPIO3 0011: GPIO4 0100: GPIO5 0101: GPIO6 0110: GPIO7 0111: GPIO8 1000: GPIO9 1001: GPIO10 1010: Reserved 1011: Reserved 1100: GPI1 1101: GPI2 1110: GPI3 1111: Reserved
D2	RESERVED	R/W	0	Reserved. Write only reset values.
D1	ASI1D_BCLK_EDGE	R/W	0	ASI1_DAC_BCLK timing per protocol is 0: normal 1: inverted
D0	AS1_BWCLK_MODE	R/W	0	ASI1 BCLK /WCLK output mode 0: ASI1_DAC_BCLK and ASI1_DAC_WCLK are active in output modes only when ASI1 is active and/or codec is powered up 1: ASI1_DAC_BCLK and ASI1_DAC_WCLK are free running.

**Book 0 / Page 1 / Register 9: ASI1 DAC WCLK Register - 0x00 / 0x01 / 0x09 (B0\_P1\_R9)**

BIT	FIELD	READ/ WRITE	RESET VALUE	DESCRIPTION
D7	RESERVED	R/W	0	Reserved. Write only reset values.
D6-D3	ASI1D_WCLK_PATH	R/W	0001	ASI1_DAC_WCLK input from 0000: GPIO1 0001: GPIO2 (Preferred pin usage) 0010: GPIO3 0011: GPIO4 0100: GPIO5 0101: GPIO6 0110: GPIO7 0111: GPIO8 1000: GPIO9 1001: GPIO10 1010: Reserved 1011: Reserved 1100: GPI1 1101: GPI2 1110: GPI3 1111: Reserved

**Book 0 / Page 1 / Register 9: ASI1 DAC WCLK Register - 0x00 / 0x01 / 0x09 (B0\_P1\_R9) (continued)**

BIT	FIELD	READ/ WRITE	RESET VALUE	DESCRIPTION
D2	RESERVED	R/W	0	Reserved. Write only reset values.
D1	ASI1D_WCLK_EDGE	R/W	0	ASI1_DAC_WCLK timing per protocol 0: normal 1: inverted
D0	RESERVED	R/W	0	Reserved. Write only reset values.

**Book 0 / Page 1 / Register 10: ASI1 ADC BCLK Register - 0x00 / 0x01 / 0x0A (B0\_P1\_R10)**

BIT	FIELD	READ/ WRITE	RESET VALUE	DESCRIPTION
D7	RESERVED	R/W	0	Reserved. Write only reset values.
D6-D3	ASI1A_BCLK_PATH	R/W	1111	ASI1_ADC_BCLK input from 0000: GPIO1 0001: GPIO2 0010: GPIO3 0011: GPIO4 0100: GPIO5 0101: GPIO6 0110: GPIO7 0111: GPIO8 1000: GPIO9 1001: GPIO10 1010: Reserved 1011: Reserved 1100: GPI1 1101: GPI2 1110: GPI3 1111: ASI1_DAC_BCLK_PATH B0_P1_R8[6:3] (Preferred usage)
D2	RESERVED	R/W	0	Reserved. Write only reset values.
D1	ASI1A_BCLK_EDGE	R/W	0	ASI1_ADC_BCLK timing per protocol is 0: normal 1: inverted
D0	RESERVED	R/W	0	Reserved. Write only reset values.

**Book 0 / Page 1 / Register 11: ASI1 ADC WCLK Register - 0x00 / 0x01 / 0x0B (B0\_P1\_R11)**

BIT	FIELD	READ/ WRITE	RESET VALUE	DESCRIPTION
D7	RESERVED	R/W	0	Reserved. Write only reset values.
D6-D3	ASI1A_WCLK_PATH	R/W	1111	ASI1_ADC_WCLK input from 0000: GPIO1 0001: GPIO2 0010: GPIO3 0011: GPIO4 0100: GPIO5 0101: GPIO6 0110: GPIO7 0111: GPIO8 1000: GPIO9 1001: GPIO10 1010: Reserved 1011: Reserved 1100: GPI1 1101: GPI2 1110: GPI3 1111: ASI1_ADC_WCLK_PATH B0_P1_R9[6:3] (Preferred usage)
D2	RESERVED	R/W	0	Reserved. Write only reset values.
D1	ASI1A_WCLK_EDGE	R/W	0	ASI1_ADC_WCLK timing per protocol is 0: normal 1: inverted
D0	RESERVED	R/W	0	Reserved. Write only reset values.

**Book 0 / Page 1 / Register 12: ASI1 DIN/DOUT MUX Register - 0x00 / 0x01 / 0x0C (B0\_P1\_R12)**

BIT	FIELD	READ/ WRITE	RESET VALUE	DESCRIPTION
D7	RESERVED	R/W	0	Reserved. Write only reset values.
D6-D3	ASI1_DIN_PATH	R/W	1100	ASI1_DIN input from 0000: GPIO1 0001: GPIO2 0010: GPIO3 0011: GPIO4 0100: GPIO5 0101: GPIO6 0110: GPIO7 0111: GPIO8 1000: GPIO9 1001: GPIO10 1010: Reserved 1011: Reserved 1100: GPI1 (Preferred pin usage) 1101: GPI2 1110: GPI3 1111: Reserved
D2	RESERVED	R/W	0	Reserved. Write only reset values.
D1-D0	ASI1_DOUT_PATH	R/W	00	ASI1_DOUT output from 00: Direct DOUT path (pin to pin loopback disabled) 01: ASI1_DIN ( Pin to Pin Loopback ) 10: ASI2_DIN ( Pin to Pin Loopback ) 11: Reserved

**Book 0 / Page 1 / Register 13: ASI1 BDIV Clock Select Register - 0x00 / 0x01 / 0x0D (B0\_P1\_R13)**

BIT	FIELD	READ/ WRITE	RESET VALUE	DESCRIPTION
D7-D3	RESERVED	R/W	0000 0	Reserved. Write only reset values.
D2-D0	ASI1_BDIV_CLKIN	R/W	001	ASI1_BDIV_CLKIN is 000: NDIV_CLK (Generated On-Chip) 001: DAC_MOD_CLK (Generated On-Chip) 010: Reserved 011: ADC_MOD_CLK (Generated On-Chip) 100: ASI1_DAC_BCLK (at pin) 101: ASI1_ADC_BCLK (at pin) 110: ASI2_DAC_BCLK (at pin) 111: ASI2_ADC_BCLK (at pin)

**Book 0 / Page 1 / Register 14: ASI1 BDIV Clock Ratio Register - 0x00 / 0x01 / 0x0E (B0\_P1\_R14)**

BIT	FIELD	READ/ WRITE	RESET VALUE	DESCRIPTION
D7	ASI1_BDIV_PWR	R/W	0	ASI1_BDIV divider is 0: powered down 1: powered up
D6-D0	ASI1_BDIV_RATIO	R/W	000 0010	ASI1_BDIV 000 0000: 128 000 0001: 1 000 0010: 2 ... 111 1110: 126 111 1111: 127

**Book 0 / Page 1 / Register 15: ASI1 WDIV Clock Ratio Register - 0x00 / 0x01 / 0x0F (B0\_P1\_R15)**

BIT	FIELD	READ/ WRITE	RESET VALUE	DESCRIPTION
D7	ASI1_WDIV_PWR	R/W	0	ASI1_WDIV divider is 0: powered down 1: powered up

**Book 0 / Page 1 / Register 15: ASI1 WDIV Clock Ratio Register - 0x00 / 0x01 / 0x0F  
(B0\_P1\_R15) (continued)**

BIT	FIELD	READ/ WRITE	RESET VALUE	DESCRIPTION
D6-D0	ASI1_WDIV_RATIO	R/W	010 0000	ASI1_WDIV 000 0000: 128 000 0001: 1 ... 010 0000 :32 ... 111 1110: 126 111 1111: 127

**Book 0 / Page 1 / Register 16: ASI1 DAC Clock Output Register - 0x00 / 0x01 / 0x10 (B0\_P1\_R16)**

BIT	FIELD	READ/ WRITE	RESET VALUE	DESCRIPTION
D7	RESERVED	R/W	0	Reserved. Write only reset values.
D6-D4	ASI1D_BCLK_OUT	R/W	000	ASI1_DAC_BCLK_OUT 000: ASI1_BDIV_OUT 001: ASI1_DAC_BCLK 010: ASI1_ADC_BCLK 011: ASI2_BDIV_OUT 100: ASI2_DAC_BCLK 101: ASI2_ADC_BCLK 110: Reserved 111: Reserved
D3	RESERVED	R/W	0	Reserved. Write only reset values.
D2-D0	ASI1D_WCLK_OUT	R/W	001	ASI1_DAC_WCLK_OUT 000: ASI1_WDIV_OUT 001: ASI1_DAC_WCLK 010: ASI1_ADC_WCLK 011: ASI2_WDIV_OUT 100: ASI2_DAC_WCLK 101: ASI2_ADC_WCLK 110: Reserved 111: Reserved

**Book 0 / Page 1 / Register 17: ASI1 ADC Clock Output Register - 0x00 / 0x01 / 0x11 (B0\_P1\_R17)**

BIT	FIELD	READ/ WRITE	RESET VALUE	DESCRIPTION
D7	RESERVED	R/W	0	Reserved. Write only reset values.
D6-D4	ASI1A_BCLK_OUT	R/W	000	ASI1_ADC_BCLK_OUT 000: ASI1_BDIV_OUT 001: ASI1_DAC_BCLK 010: ASI1_ADC_BCLK 011: ASI2_BDIV_OUT 100: ASI2_DAC_BCLK 101: ASI2_ADC_BCLK 110: Reserved 111: Reserved
D3	RESERVED	R/W	0	Reserved. Write only reset values.
D2-D0	ASI1A_WCLK_OUT	R/W	001	ASI1_ADC_WCLK_OUT 000: ASI1_WDIV_OUT 001: ASI1_DAC_WCLK 010: ASI1_ADC_WCLK 011: ASI2_WDIV_OUT 100: ASI2_DAC_WCLK 101: ASI2_ADC_WCLK 110: Reserved 111: Reserved

**Book 0 / Page 1 / Register 18-20: Reserved Registers - 0x00 / 0x01 / 0x12-0x14 (B0\_P1\_R18-20)**

BIT	FIELD	READ/ WRITE	RESET VALUE	DESCRIPTION
D7-D0	RESERVED	R	xxxx xxxx	Reserved.

**Book 0 / Page 1 / Register 21: ASI2 DAC Format Register - 0x00 / 0x01 / 0x15 (B0\_P1\_R21)**

BIT	FIELD	READ/ WRITE	RESET VALUE	DESCRIPTION
D7-D5	ASI2D_INTERFACE	R/W	000	ASI2 DAC interface is 000: I2S 001: DSP 010: Right Justified (RJF). Non-zero values of ASI2_OFFSET not supported. 011: Left Justified (LJF) 100: MonoPCM 101-111: Reserved
D4-D3	ASI2D_WORD_LEN	R/W	10	ASI2 DAC word length is 00: 16 bits 01: 20 bits 10: 24 bits 11: 32 bits
D2-D1	RESERVED	R/W	00	Reserved. Write only reset values.
D0	ASI2_TRISTATE	R/W	0	Tristating of DOUT1 for the extra ASI2_BCLK cycles after Data Transfer is over for a frame 0: Disabled 1: Enabled

**Book 0 / Page 1 / Register 22: ASI2 ADC Format Register - 0x00 / 0x01 / 0x16 (B0\_P1\_R22)**

BIT	FIELD	READ/ WRITE	RESET VALUE	DESCRIPTION
D7-D5	ASI2A_INTERFACE	R/W	000	ASI2 ADC interface is (This register control is valid only if D0 = 1) 000: I2S 001: DSP 010: Right Justified (RJF). Non-zero values of ASI2_OFFSET not supported. 011: Left Justified (LJF) 100: MonoPCM 101-111: Reserved
D4-D3	ASI2A_WORD_LEN	R/W	00	ASI2 ADC word length is (This register control is valid only if D0 = 1) 00: 16 bits 01: 20 bits 10: 24 bits 11: 32 bits
D2-D1	RESERVED	R/W	00	Reserved. Write only reset values.
D0	ASI2A_USE_DAC	R/W	0	ASI2 ADC uses 0: the same Interface type and word length as DAC side as in B0_P1_R1 1: the Interface type and word length from B0_P1_R2[7:3]

**Book 0 / Page 1 / Register 23: ASI2 Offset Register - 0x00 / 0x01 / 0x17 (B0\_P1\_R23)**

BIT	FIELD	READ/ WRITE	RESET VALUE	DESCRIPTION
D7-D0	ASI2_OFFSET	R/W	0000 0000	ASI2_OFFSET = x ASI2_BCLK's. Offset is measured with respect to WCLK-rising edge in DSP Mode. Offset is not supported for RJF mode 0000 0000: 0 ASI2_BCLK's 0000 0001: 1 ASI2_BCLK's ... 1111 1110: 254 ASI2_BCLK's 1111 1111: 255 ASI2_BCLK's

**Book 0 / Page 1 / Register 24-26: Reserved Registers - 0x00 / 0x01 / 0x18-0x1A (B0\_P1\_R24-26)**

BIT	FIELD	READ/ WRITE	RESET VALUE	DESCRIPTION
D7-D0	RESERVED	R	xxxx xxxx	Reserved.

**Book 0 / Page 1 / Register 27: ASI2 ADC Path Register - 0x00 / 0x01 / 0x1B (B0\_P1\_R27)**

BIT	FIELD	READ/ WRITE	RESET VALUE	DESCRIPTION
D7-D3	RESERVED	R	0000 0	Reserved. Write only reset values.
D2-D0	ASI2A_PATH	R/W	010	ASI2 ADC Path is 000: ASI2_ADC_DATA is disabled. No serial data output from ASI2 001: Reserved 010: ASI2_ADC_DATA <Left,Right> = DSP_OUT<Left,Right> 011: Reserved 100: Reserved 101: ASI1_ADC_DATA<Left,Right> = ASI1_CHANNEL<Left,Right> 110: ASI1_ADC_DATA<Left,Right> = ASI2_CHANNEL<Left,Right> 111: Reserved

**Book 0 / Page 1 / Register 28: ASI2 DAC BCLK Register - 0x00 / 0x01 / 0x1C (B0\_P1\_R28)**

BIT	FIELD	READ/ WRITE	RESET VALUE	DESCRIPTION
D7	RESERVED	R/W	0	Reserved. Write only reset values.
D6-D3	ASI2D_BCLK_PATH	R/W	0100	ASI1_DAC_BCLK input from 0000: GPIO1 0001: GPIO2 0010: GPIO3 0011: GPIO4 0100: GPIO5 (Preferred pin usage) 0101: GPIO6 0110: GPIO7 0111: GPIO8 1000: GPIO9 1001: GPIO10 1010: Reserved 1011: Reserved 1100: GPI1 1101: GPI2 1110: GPI3 1111: Reserved
D2	RESERVED	R/W	0	Reserved. Write only reset values.
D1	ASI2D_BCLK_EDGE	R/W	0	ASI2_DAC_BCLK timing per protocol is 0: normal 1: inverted
D0	ASI2_BWCLK_MODE	R/W	0	ASI2 BCLK /WCLK output mode is 0: ASI2_DAC_BCLK and ASI2_DAC_WCLK are active in output modes only when ASI2 is active and/or codec is powered up 1: ASI2_DAC_BCLK and ASI2_DAC_WCLK are free running.

**Book 0 / Page 1 / Register 29: ASI2 DAC WCLK Register - 0x00 / 0x01 / 0x1D (B0\_P1\_R29)**

BIT	FIELD	READ/ WRITE	RESET VALUE	DESCRIPTION
D7	RESERVED	R/W	0	Reserved. Write only reset values.

**Book 0 / Page 1 / Register 29: ASI2 DAC WCLK Register - 0x00 / 0x01 / 0x1D (B0\_P1\_R29) (continued)**

BIT	FIELD	READ/ WRITE	RESET VALUE	DESCRIPTION
D6-D3	ASI2_WCLK_PATH	R/W	0101	ASI2_DAC_WCLK input from 0000: GPIO1 0001: GPIO2 0010: GPIO3 0011: GPIO4 0100: GPIO5 0101: GPIO6 (Preferred pin usage) 0110: GPIO7 0111: GPIO8 1000: GPIO9 1001: GPIO10 1010: Reserved 1011: Reserved 1100: GPI1 1101: GPI2 1110: GPI3 1111: Reserved
D2	RESERVED	R/W	0	Reserved. Write only reset values.
D1	ASI2D_WCLK_EDGE	R/W	0	ASI2_DAC_WCLK timing per protocol is 0: normal 1: inverted
D0	RESERVED	R/W	0	Reserved. Write only reset values.

**Book 0 / Page 1 / Register 30: ASI2 ADC BCLK Register - 0x00 / 0x01 / 0x1E (B0\_P1\_R30)**

BIT	FIELD	READ/ WRITE	RESET VALUE	DESCRIPTION
D7	RESERVED	R/W	0	Reserved. Write only reset values.
D6-D3	ASI2A_BCLK_PATH	R/W	1111	ASI2_ADC_BCLK input from 0000: GPIO1 0001: GPIO2 0010: GPIO3 0011: GPIO4 0100: GPIO5 0101: GPIO6 0110: GPIO7 0111: GPIO8 1000: GPIO9 1001: GPIO10 1010: Reserved 1011: Reserved 1100: GPI1 1101: GPI2 1110: GPI3 1111: ASI2_DAC_BCLK_PATH B0_P1_R28[6:3] (Preferred usage)
D2	RESERVED	R/W	0	Reserved. Write only reset values.
D1	ASI2A_BCLK_EDGE	R/W	0	ASI2_ADC_BCLK timing per protocol is 0: normal 1: inverted
D0	RESERVED	R/W	0	Reserved. Write only reset values.

**Book 0 / Page 1 / Register 31: ASI2 ADC WCLK Register - 0x00 / 0x01 / 0x1F (B0\_P1\_R31)**

BIT	FIELD	READ/ WRITE	RESET VALUE	DESCRIPTION
D7	RESERVED	R/W	0	Reserved. Write only reset values.

**Book 0 / Page 1 / Register 31: ASI2 ADC WCLK Register - 0x00 / 0x01 / 0x1F (B0\_P1\_R31) (continued)**

BIT	FIELD	READ/ WRITE	RESET VALUE	DESCRIPTION
D6-D3	ASI1A_WCLK_PATH	R/W	1111	ASI1_ADC_WCLK input from 0000: GPIO1 0001: GPIO2 0010: GPIO3 0011: GPIO4 0100: GPIO5 0101: GPIO6 0110: GPIO7 0111: GPIO8 1000: GPIO9 1001: GPIO10 1010: Reserved 1011: Reserved 1100: GPI1 1101: GPI2 1110: GPI3 1111: ASI2_DAC_WCLK_PATH B0_P1_R29[6:3] (Preferred usage)
D2	RESERVED	R/W	0	Reserved. Write only reset values.
D1	ASI1A_WCLK_EDGE	R/W	0	ASI2_ADC_WCLK timing per protocol is 0: normal 1: inverted
D0	RESERVED	R/W	0	Reserved. Write only reset values.

**Book 0 / Page 1 / Register 32: ASI2 DIN/DOU MUX - 0x00 / 0x01 / 0x20 (B0\_P1\_R32)**

BIT	FIELD	READ/ WRITE	RESET VALUE	DESCRIPTION
D7	RESERVED	R/W	0	Reserved. Write only reset values.
D6-D3	ASI2_IPATH	R/W	0111	ASI2_DIN input from 0000: GPIO1 0001: GPIO2 0010: GPIO3 0011: GPIO4 0100: GPIO5 0101: GPIO6 0110: GPIO7 0111: GPIO8 (Preferred pin usage) 1000: GPIO9 1001: GPIO10 1010: Reserved 1011: Reserved 1100: GPI1 1101: GPI2 1110: GPI3 1111: Reserved
D2	RESERVED	R/W	0	Reserved. Write only reset values.
D1-D0	ASI2_OPATH	R/W	00	ASI2_DOU output from 00: Direct DOU path (pin to pin loopback disabled) 01: ASI1_DIN ( Pin to Pin Loopback ) 10: ASI2_DIN ( Pin to Pin Loopback ) 11: Reserved

**Book 0 / Page 1 / Register 33: ASI2 BDIV Clock Select Register - 0x00 / 0x01 / 0x21 (B0\_P1\_R33)**

BIT	FIELD	READ/ WRITE	RESET VALUE	DESCRIPTION
D7-D3	RESERVED	R/W	0000 0	Reserved. Write only reset values.

**Book 0 / Page 1 / Register 33: ASI2 BDIV Clock Select Register - 0x00 / 0x01 / 0x21  
(B0\_P1\_R33) (continued)**

BIT	FIELD	READ/ WRITE	RESET VALUE	DESCRIPTION
D2-D0	ASI1_BDIV_CLKIN	R/W	001	ASI2_BDIV_CLKIN 000: NDIV_CLK (Generated On-Chip) 001: DAC_MOD_CLK (Generated On-Chip) 010: Reserved 011: ADC_MOD_CLK (Generated On-Chip) 100: ASI1_DAC_BCLK (at pin) 101: ASI1_ADC_BCLK (at pin) 110: ASI2_DAC_BCLK (at pin) 111: ASI2_ADC_BCLK (at pin)

**Book 0 / Page 1 / Register 34: ASI2 BDIV Clock Ratio Register - 0x00 / 0x01 / 0x22 (B0\_P1\_R34)**

BIT	FIELD	READ/ WRITE	RESET VALUE	DESCRIPTION
D7	ASI2_BDIV_PWR	R/W	0	ASI2_BDIV divider is 0: powered down 1: powered up
D6-D0	ASI2_BDIV_RTO	R/W	000 0010	ASI2_BDIV 000 0000: 128 000 0001: 1 000 0010: 2 ... 111 1110: 126 111 1111: 127

**Book 0 / Page 1 / Register 35: ASI2 WDIV Clock Ratio Register - 0x00 / 0x01 / 0x23 (B0\_P1\_R35)**

BIT	FIELD	READ/ WRITE	RESET VALUE	DESCRIPTION
D7	ASI2_WDIV_PWR	R/W	0	ASI2_WDIV divider is 0: powered down 1: powered up
D6-D0	ASI2_WDIV_RTO	R/W	010 0000	ASI2_BDIV Ratio 000 0000: 128 000 0001: 1 ... 010 0000 :32 ... 111 1110: 126 111 1111: 127

**Book 0 / Page 1 / Register 36: ASI2 DAC Clock Output Register - 0x00 / 0x01 / 0x24 (B0\_P1\_R36)**

BIT	FIELD	READ/ WRITE	RESET VALUE	DESCRIPTION
D7	RESERVED	R/W	0	Reserved. Write only reset values.
D6-D4	ASI2D_BCLKO	R/W	011	ASI2_DAC_BCLK_OUT 000: ASI1_BDIV_OUT 001: ASI1_DAC_BCLK 010: ASI1_ADC_BCLK 011: ASI2_BDIV_OUT 100: ASI2_DAC_BCLK 101: ASI2_ADC_BCLK 110: Reserved 111: Reserved
D3	RESERVED	R/W	0	Reserved. Write only reset values.

**Book 0 / Page 1 / Register 36: ASI2 DAC Clock Output Register - 0x00 / 0x01 / 0x24  
(B0\_P1\_R36) (continued)**

BIT	FIELD	READ/ WRITE	RESET VALUE	DESCRIPTION
D2-D0	ASI2D_WCLKO	R/W	011	ASI2_DAC_WCLK_OUT 000: ASI1_WDIV_OUT 001: ASI1_DAC_WCLK 010: ASI1_ADC_WCLK 011: ASI2_WDIV_OUT 100: ASI2_DAC_WCLK 101: ASI2_ADC_WCLK 110: Reserved 111: Reserved

**Book 0 / Page 1 / Register 37: ASI2 ADC Clock Output Register - 0x00 / 0x01 / 0x25 (B0\_P1\_R37)**

BIT	FIELD	READ/ WRITE	RESET VALUE	DESCRIPTION
D7	RESERVED	R/W	0	Reserved. Write only reset values.
D6-D4	ASI2A_BCLKO	R/W	011	ASI2_ADC_BCLK_OUT 000: ASI1_BDIV_OUT 001: ASI1_DAC_BCLK 010: ASI1_ADC_BCLK 011: ASI2_BDIV_OUT 100: ASI2_DAC_BCLK 101: ASI2_ADC_BCLK 110: Reserved 111: Reserved
D3	RESERVED	R/W	0	Reserved. Write only reset values.
D2-D0	ASI2A_WCLKO	R/W	011	ASI2_ADC_WCLK_OUT 000: ASI1_WDIV_OUT 001: ASI1_DAC_WCLK 010: ASI1_ADC_WCLK 011: ASI2_WDIV_OUT 100: ASI2_DAC_WCLK 101: ASI2_ADC_WCLK 110: Reserved 111: Reserved

**Book 0 / Page 1 / Register 38-60: Reserved Registers - 0x00 / 0x01 / 0x26-0x3C (B0\_P1\_R38-60)**

BIT	FIELD	READ/ WRITE	RESET VALUE	DESCRIPTION
D7-D0	RESERVED	R	xxxx xxxx	Reserved.

**Book 0 / Page 1 / Register 61: BCLK1\_GPIO1 Pin Register - 0x00 / 0x01 / 0x3D (B0\_P1\_R61)**

BIT	FIELD	READ/ WRITE	RESET VALUE	DESCRIPTION
D7	RESERVED	R/W	0	Reserved. Write only reset values.
D6	GPIO1_OVAL	R/W	0	GPIO1 general purpose output value is 0: Low(0) 1: High(1)
D5	RESERVED	R/W	0	Reserved. Write only reset values.

**Book 0 / Page 1 / Register 61: BCLK1\_GPIO1 Pin Register - 0x00 / 0x01 / 0x3D (B0\_P1\_R61) (continued)**

BIT	FIELD	READ/ WRITE	RESET VALUE	DESCRIPTION
D4-D0	GPIO1_FUNCT	R/W	0 0001	Pin BCLK1_GPIO1 function is 0 0000: Disabled (Input and Output buffers powered down) 0 0001: Input mode 0 0010: Reserved 0 0011: Output = General Purpose Output level set by bit D6 0 0100: Output = General Purpose Output level set by B0_P1_R88 & B0_P1_R87 0 0101: Output = Reserved 0 0110: Output = CLKOUT Output 0 0111: Output = INT1 Interrupt Output 0 1000: Output = INT2 Interrupt Output 0 1001: Output = INT3 Interrupt Output 0 1010: Output = INT4 Interrupt Output 0 1011: Reserved 0 1100: Output = ASI1 word clock output 0 1101: Output = ASI1 bit clock output 0 1110: Output = ASI1_WCLK_ADC_OUT 0 1111: Output = ASI1_BCLK_ADC_OUT 1 0000: Output = ASI1_DOUT 1 0001: Output = ASI2_WCLK_OUT 1 0010: Output = ASI2_BCLK_OUT 1 0011: Output = ASI2_WCLK_ADC_OUT 1 0100: Output = ASI2_BCLK_ADC_OUT 1 0101: Output = ASI2_DOUT 1 0110: Output = ASIM_WCLK_OUT 1 0111: Output = ASIM_BCLK_OUT 1 1000: Output = ASIM_DOUT 1 1001: Reserved ... 1 1111: Reserved

**Book 0 / Page 1 / Register 62: WCLK1\_GPIO2 Pin Register - 0x00 / 0x01 / 0x3E (B0\_P1\_R62)**

BIT	FIELD	READ/ WRITE	RESET VALUE	DESCRIPTION
D7	RESERVED	R/W	0	Reserved. Write only reset values.
D6	GPIO2_OVAL	R/W	0	GPIO2 general purpose output value is 0: Low(0) 1: High(1)
D5	RESERVED	R/W	0	Reserved. Write only reset values.

**Book 0 / Page 1 / Register 62: WCLK1\_GPIO2 Pin Register - 0x00 / 0x01 / 0x3E (B0\_P1\_R62) (continued)**

BIT	FIELD	READ/ WRITE	RESET VALUE	DESCRIPTION
D4-D0	GPIO2_FUNC	R/W	0 0001	Pin WCLK1_GPIO2 function is 0 0000: Disabled (Input and Output buffers powered down) 0 0001: Input mode 0 0010: Reserved 0 0011: Output = General Purpose Output level set by bit D6 0 0100: Output = General Purpose Output level set by B0_P1_R88 & B0_P1_R87 0 0101: Output = Reserved 0 0110: Output = CLKOUT Output 0 0111: Output = INT1 Interrupt Output 0 1000: Output = INT2 Interrupt Output 0 1001: Output = INT3 Interrupt Output 0 1010: Output = INT4 Interrupt Output 0 1011: Reserved 0 1100: Output = ASI1_WCLK_OUT 0 1101: Output = ASI1_BCLK_OUT 0 1110: Output = ASI1_WCLK_ADC_OUT 0 1111: Output = ASI1_BCLK_ADC_OUT 1 0000: Output = ASI1_DOUT 1 0001: Output = ASI2_WCLK_OUT 1 0010: Output = ASI2_BCLK_OUT 1 0011: Output = ASI2_WCLK_ADC_OUT 1 0100: Output = ASI2_BCLK_ADC_OUT 1 0101: Output = ASI2_DOUT 1 0110: Output = ASIM_WCLK_OUT 1 0111: Output = ASIM_BCLK_OUT 1 1000: Output = ASIM_DOUT 1 1001: Reserved ... 1 1111: Reserved

**Book 0 / Page 1 / Register 63: DOUT1\_GPIO3 Pin Register - 0x00 / 0x01 / 0x3F (B0\_P1\_R63)**

BIT	FIELD	READ/ WRITE	RESET VALUE	DESCRIPTION
D7	RESERVED	R/W	0	Reserved. Write only reset values.
D6	GPIO3_OVAL	R/W	0	GPIO3 general purpose output value is 0: Low(0) 1: High(1)
D5	RESERVED	R/W	0	Reserved. Write only reset values.

**Book 0 / Page 1 / Register 63: DOUT1\_GPIO3 Pin Register - 0x00 / 0x01 / 0x3F (B0\_P1\_R63) (continued)**

BIT	FIELD	READ/ WRITE	RESET VALUE	DESCRIPTION
D4-D0	GPIO3_FUNC	R/W	1 0000	Pin DOUT1_GPIO3 function is 0 0000: Disabled (Input and Output buffers powered down) 0 0001: Input mode 0 0010: Reserved 0 0011: Output = General Purpose Output level set by bit D6 0 0100: Output = General Purpose Output level set by B0_P1_R88 & B0_P1_R87 0 0101: Output = Reserved 0 0110: Output = CLKOUT Output 0 0111: Output = INT1 Interrupt Output 0 1000: Output = INT2 Interrupt Output 0 1001: Output = INT3 Interrupt Output 0 1010: Output = INT4 Interrupt Output 0 1011: Reserved 0 1100: Output = ASI1_WCLK_OUT 0 1101: Output = ASI1_BCLK_OUT 0 1110: Output = ASI1_WCLK_ADC_OUT 0 1111: Output = ASI1_BCLK_ADC_OUT 1 0000: Output = ASI1_DOUT 1 0001: Output = ASI2_WCLK_OUT 1 0010: Output = ASI2_BCLK_OUT 1 0011: Output = ASI2_WCLK_ADC_OUT 1 0100: Output = ASI2_BCLK_ADC_OUT 1 0101: Output = ASI2_DOUT 1 0110: Output = ASIM_WCLK_OUT 1 0111: Output = ASIM_BCLK_OUT 1 1000: Output = ASIM_DOUT 1 1001: Reserved ... 1 1111: Reserved

**Book 0 / Page 1 / Register 64: IRQ\_GPIO4 Pin Register - 0x00 / 0x01 / 0x40 (B0\_P1\_R64)**

BIT	FIELD	READ/ WRITE	RESET VALUE	DESCRIPTION
D7	RESERVED	R/W	0	Reserved. Write only reset values.
D6	GPIO4_OVAL	R/W	0	GPIO4 general purpose output value is 0: Low(0) 1: High(1)
D5	RESERVED	R/W	0	Reserved. Write only reset values.

**Book 0 / Page 1 / Register 64: IRQ\_GPIO4 Pin Register - 0x00 / 0x01 / 0x40 (B0\_P1\_R64) (continued)**

BIT	FIELD	READ/ WRITE	RESET VALUE	DESCRIPTION
D4-D0	GPIO4_FUNC	R/W	0 0111	Pin IRQ_GPIO4 function is 0 0000: Disabled (Input and Output buffers powered down) 0 0001: Input mode 0 0010: Reserved 0 0011: Output = General Purpose Output level set by bit D6 0 0100: Output = General Purpose Output level set by B0_P1_R88 & B0_P1_R87 0 0101: Output = Reserved 0 0110: Output = CLKOUT Output 0 0111: Output = INT1 Interrupt Output 0 1000: Output = INT2 Interrupt Output 0 1001: Output = INT3 Interrupt Output 0 1010: Output = INT4 Interrupt Output 0 1011: Reserved 0 1100: Output = ASI1_WCLK_OUT 0 1101: Output = ASI1_BCLK_OUT 0 1110: Output = ASI1_WCLK_ADC_OUT 0 1111: Output = ASI1_BCLK_ADC_OUT 1 0000: Output = ASI1_DOUT 1 0001: Output = ASI2_WCLK_OUT 1 0010: Output = ASI2_BCLK_OUT 1 0011: Output = ASI2_WCLK_ADC_OUT 1 0100: Output = ASI2_BCLK_ADC_OUT 1 0101: Output = ASI2_DOUT 1 0110: Output = ASIM_WCLK_OUT 1 0111: Output = ASIM_BCLK_OUT 1 1000: Output = ASIM_DOUT 1 1001: Reserved ... 1 1111: Reserved

**Book 0 / Page 1 / Register 65: BCLK2\_GPIO5 Pin Register - 0x00 / 0x01 / 0x41 (B0\_P1\_R65)**

BIT	FIELD	READ/ WRITE	RESET VALUE	DESCRIPTION
D7	RESERVED	R/W	0	Reserved. Write only reset values.
D6	GPIO5_OVAL	R/W	0	GPIO5 general purpose output value is 0: Low(0) 1: High(1)
D5	RESERVED	R/W	0	Reserved. Write only reset values.

**Book 0 / Page 1 / Register 65: BCLK2\_GPIO5 Pin Register - 0x00 / 0x01 / 0x41 (B0\_P1\_R65) (continued)**

BIT	FIELD	READ/ WRITE	RESET VALUE	DESCRIPTION
D4-D0	GPIO5_FUNC	R/W	0 0000	Pin BCLK2_GPIO5 function is 0 0000: Disabled (Input and Output buffers powered down) 0 0001: Input mode 0 0010: Reserved 0 0011: Output = General Purpose Output level set by bit D6 0 0100: Output = General Purpose Output level set by B0_P1_R88 & B0_P1_R87 0 0101: Output = Reserved 0 0110: Output = CLKOUT Output 0 0111: Output = INT1 Interrupt Output 0 1000: Output = INT2 Interrupt Output 0 1001: Output = INT3 Interrupt Output 0 1010: Output = INT4 Interrupt Output 0 1011: Reserved 0 1100: Output = ASI1_WCLK_OUT 0 1101: Output = ASI1_BCLK_OUT 0 1110: Output = ASI1_WCLK_ADC_OUT 0 1111: Output = ASI1_BCLK_ADC_OUT 1 0000: Output = ASI1_DOUT 1 0001: Output = ASI2_WCLK_OUT 1 0010: Output = ASI2_BCLK_OUT 1 0011: Output = ASI2_WCLK_ADC_OUT 1 0100: Output = ASI2_BCLK_ADC_OUT 1 0101: Output = ASI2_DOUT 1 0110: Output = ASIM_WCLK_OUT 1 0111: Output = ASIM_BCLK_OUT 1 1000: Output = ASIM_DOUT 1 1001: Reserved ... 1 1111: Reserved

**Book 0 / Page 1 / Register 66: WCLK2\_GPIO6 Pin Register - 0x00 / 0x01 / 0x42 (B0\_P1\_R66)**

BIT	FIELD	READ/ WRITE	RESET VALUE	DESCRIPTION
D7	RESERVED	R/W	0	Reserved. Write only reset values.
D6	GPIO6_OVAL	R/W	0	GPIO6 general purpose output value is 0: Low(0) 1: High(1)
D5	RESERVED	R/W	0	Reserved. Write only reset values.

**Book 0 / Page 1 / Register 66: WCLK2\_GPIO6 Pin Register - 0x00 / 0x01 / 0x42 (B0\_P1\_R66) (continued)**

BIT	FIELD	READ/ WRITE	RESET VALUE	DESCRIPTION
D4-D0	GPIO6_FUNC	R/W	0 0000	Pin WCLK2_GPIO6 function is 0 0000: Disabled (Input and Output buffers powered down) 0 0001: Input mode 0 0010: Reserved 0 0011: Output = General Purpose Output level set by bit D6 0 0100: Output = General Purpose Output level set by B0_P1_R88 & B0_P1_R87 0 0101: Output = Reserved 0 0110: Output = CLKOUT Output 0 0111: Output = INT1 Interrupt Output 0 1000: Output = INT2 Interrupt Output 0 1001: Output = INT3 Interrupt Output 0 1010: Output = INT4 Interrupt Output 0 1011: Reserved 0 1100: Output = ASI1_WCLK_OUT 0 1101: Output = ASI1_BCLK_OUT 0 1110: Output = ASI1_WCLK_ADC_OUT 0 1111: Output = ASI1_BCLK_ADC_OUT 1 0000: Output = ASI1_DOUT 1 0001: Output = ASI2_WCLK_OUT 1 0010: Output = ASI2_BCLK_OUT 1 0011: Output = ASI2_WCLK_ADC_OUT 1 0100: Output = ASI2_BCLK_ADC_OUT 1 0101: Output = ASI2_DOUT 1 0110: Output = ASIM_WCLK_OUT 1 0111: Output = ASIM_BCLK_OUT 1 1000: Output = ASIM_DOUT 1 1001: Reserved ... 1 1111: Reserved

**Book 0 / Page 1 / Register 67: DOUT2\_GPIO7 Pin Register - 0x00 / 0x01 / 0x43 (B0\_P1\_R67)**

BIT	FIELD	READ/ WRITE	RESET VALUE	DESCRIPTION
D7	RESERVED	R/W	0	Reserved. Write only reset values.
D6	GPIO7_OVAL	R/W	0	GPIO7 general purpose output value is 0: Low(0) 1: High(1)
D5	RESERVED	R/W	0	Reserved. Write only reset values.

**Book 0 / Page 1 / Register 67: DOUT2\_GPIO7 Pin Register - 0x00 / 0x01 / 0x43 (B0\_P1\_R67) (continued)**

BIT	FIELD	READ/ WRITE	RESET VALUE	DESCRIPTION
D4-D0	GPIO7_FUNC	R/W	0 0000	Pin DOUT2_GPIO7 function is 0 0000: Disabled (Input and Output buffers powered down) 0 0001: Input mode 0 0010: Reserved 0 0011: Output = General Purpose Output level set by bit D6 0 0100: Output = General Purpose Output level set by B0_P1_R88 & B0_P1_R87 0 0101: Output = Reserved 0 0110: Output = CLKOUT Output 0 0111: Output = INT1 Interrupt Output 0 1000: Output = INT2 Interrupt Output 0 1001: Output = INT3 Interrupt Output 0 1010: Output = INT4 Interrupt Output 0 1011: Reserved 0 1100: Output = ASI1_WCLK_OUT 0 1101: Output = ASI1_BCLK_OUT 0 1110: Output = ASI1_WCLK_ADC_OUT 0 1111: Output = ASI1_BCLK_ADC_OUT 1 0000: Output = ASI1_DOUT 1 0001: Output = ASI2_WCLK_OUT 1 0010: Output = ASI2_BCLK_OUT 1 0011: Output = ASI2_WCLK_ADC_OUT 1 0100: Output = ASI2_BCLK_ADC_OUT 1 0101: Output = ASI2_DOUT 1 0110: Output = ASIM_WCLK_OUT 1 0111: Output = ASIM_BCLK_OUT 1 1000: Output = ASIM_DOUT 1 1001: Reserved ... 1 1111: Reserved

**Book 0 / Page 1 / Register 68: DIN2\_GPIO8 Pin Register - 0x00 / 0x01 / 0x44 (B0\_P1\_R68)**

BIT	FIELD	READ/ WRITE	RESET VALUE	DESCRIPTION
D7	RESERVED	R/W	0	Reserved. Write only reset values.
D6	GPIO8_OVAL	R/W	0	GPIO8 general purpose output value is 0: Low(0) 1: High(1)
D5	RESERVED	R/W	0	Reserved. Write only reset values.

**Book 0 / Page 1 / Register 68: DIN2\_GPIO8 Pin Register - 0x00 / 0x01 / 0x44 (B0\_P1\_R68) (continued)**

BIT	FIELD	READ/ WRITE	RESET VALUE	DESCRIPTION
D4-D0	GPIO8_FUNC	R/W	0 0000	Pin DIN2_GPIO8 function is 0 0000: Disabled (Input and Output buffers powered down) 0 0001: Input mode 0 0010: Reserved 0 0011: Output = General Purpose Output level set by bit D6 0 0100: Output = General Purpose Output level set by B0_P1_R88 & B0_P1_R87 0 0101: Output = Reserved 0 0110: Output = CLKOUT Output 0 0111: Output = INT1 Interrupt Output 0 1000: Output = INT2 Interrupt Output 0 1001: Output = INT3 Interrupt Output 0 1010: Output = INT4 Interrupt Output 0 1011: Reserved 0 1100: Output = ASI1_WCLK_OUT 0 1101: Output = ASI1_BCLK_OUT 0 1110: Output = ASI1_WCLK_ADC_OUT 0 1111: Output = ASI1_BCLK_ADC_OUT 1 0000: Output = ASI1_DOUT 1 0001: Output = ASI2_WCLK_OUT 1 0010: Output = ASI2_BCLK_OUT 1 0011: Output = ASI2_WCLK_ADC_OUT 1 0100: Output = ASI2_BCLK_ADC_OUT 1 0101: Output = ASI2_DOUT 1 0110: Output = ASIM_WCLK_OUT 1 0111: Output = ASIM_BCLK_OUT 1 1000: Output = ASIM_DOUT 1 1001: Reserved ... 1 1111: Reserved

**Book 0 / Page 1 / Register 69: ICC\_GPIO9 Pin(ICC\_CLK) Register - 0x00 / 0x01 / 0x45 (B0\_P1\_R69)**

BIT	FIELD	READ/ WRITE	RESET VALUE	DESCRIPTION
D7	RESERVED	R/W	0	Reserved. Write only reset values.
D6	GPIO9_OVAL	R/W	0	GPIO9 general purpose output value is 0: Low(0) 1: High(1)
D5	RESERVED	R/W	0	Reserved. Write only reset values.

**Book 0 / Page 1 / Register 69: ICC\_GPIO9 Pin(ICC\_CLK) Register - 0x00 / 0x01 / 0x45  
(B0\_P1\_R69) (continued)**

BIT	FIELD	READ/ WRITE	RESET VALUE	DESCRIPTION
D4-D0	GPIO9_FUNC	R/W	0 0000	Pin ICC_GPIO9 function is 0 0000: Disabled (Input and Output buffers powered down) 0 0001: Input mode 0 0010: Reserved 0 0011: Output = General Purpose Output level set by bit D6 0 0100: Output = General Purpose Output level set by B0_P1_R88 & B0_P1_R87 0 0101: Output = Reserved 0 0110: Output = CLKOUT Output 0 0111: Output = INT1 Interrupt Output 0 1000: Output = INT2 Interrupt Output 0 1001: Output = INT3 Interrupt Output 0 1010: Output = INT4 Interrupt Output 0 1011: Reserved 0 1100: Output = ASI1_WCLK_OUT 0 1101: Output = ASI1_BCLK_OUT 0 1110: Output = ASI1_WCLK_ADC_OUT 0 1111: Output = ASI1_BCLK_ADC_OUT 1 0000: Output = ASI1_DOUT 1 0001: Output = ASI2_WCLK_OUT 1 0010: Output = ASI2_BCLK_OUT 1 0011: Output = ASI2_WCLK_ADC_OUT 1 0100: Output = ASI2_BCLK_ADC_OUT 1 0101: Output = ASI2_DOUT 1 0110: Output = ASIM_WCLK_OUT 1 0111: Output = ASIM_BCLK_OUT 1 1000: Output = ASIM_DOUT 1 1001: Reserved ... 1 1111: Reserved

**Book 0 / Page 1 / Register 70: ICC\_GPIO10 Pin Register - 0x00 / 0x01 / 0x46 (B0\_P1\_R70)**

BIT	FIELD	READ/ WRITE	RESET VALUE	DESCRIPTION
D7	RESERVED	R/W	0	Reserved. Write only reset values.
D6	GPIO10_OUT_VAL	R/W	0	GPIO10 General Purpose Output Value 0: Low(0) 1: High(1)
D5	RESERVED	R/W	0	Reserved. Write only reset values.

**Book 0 / Page 1 / Register 70: ICC\_GPIO10 Pin Register - 0x00 / 0x01 / 0x46 (B0\_P1\_R70) (continued)**

BIT	FIELD	READ/ WRITE	RESET VALUE	DESCRIPTION
D4-D0	GPIO10_FUNC	R/W	0 0000	GPIO10 Function 0 0000: Disabled (Input and Output buffers powered down) 0 0001: Input mode 0 0010: Reserved 0 0011: Output = General Purpose Output level set by bit D6 0 0100: Output = General Purpose Output level set by B0_P1_R88 & B0_P1_R87 0 0101: Output = Reserved 0 0110: Output = CLKOUT Output 0 0111: Output = INT1 Interrupt Output 0 1000: Output = INT2 Interrupt Output 0 1001: Output = INT3 Interrupt Output 0 1010: Output = INT4 Interrupt Output 0 1011: Reserved 0 1100: Output = ASI1_WCLK_OUT 0 1101: Output = ASI1_BCLK_OUT 0 1110: Output = ASI1_WCLK_ADC_OUT 0 1111: Output = ASI1_BCLK_ADC_OUT 1 0000: Output = ASI1_DOUT 1 0001: Output = ASI2_WCLK_OUT 1 0010: Output = ASI2_BCLK_OUT 1 0011: Output = ASI2_WCLK_ADC_OUT 1 0100: Output = ASI2_BCLK_ADC_OUT 1 0101: Output = ASI2_DOUT 1 0110: Output = ASIM_WCLK_OUT 1 0111: Output = ASIM_BCLK_OUT 1 1000: Output = ASIM_DOUT 1 1001: Reserved ... 1 1111: Reserved

**Book 0 / Page 1 / Register 71-76: Reserved Registers - 0x00 / 0x01 / 0x47-0x4C (B0\_P1\_R71-76)**

BIT	FIELD	READ/ WRITE	RESET VALUE	DESCRIPTION
D7-D0	RESERVED	R	xxxx xxxx	Reserved

**Book 0 / Page 1 / Register 77: GPI Pins Register - 0x00 / 0x01 / 0x4D (B0\_P1\_R77)**

BIT	FIELD	READ/ WRITE	RESET VALUE	DESCRIPTION
D7-D6	RESERVED	R/W	00	Reserved. Write only reset values.
D5-D4	GPI3_FUNC	R/W	00	Pin ICC_GPI3 is 00: Disabled (Input powered down) 01: In Input mode 10: Reserved 11: Reserved
D3-D2	GPI2_FUNC	R/W	01	Pin MCLK_GPI2 is 00: Disabled (Input powered down) 01: Input mode 10: Reserved 11: Reserved
D1-D0	GPI1_FUNC	R/W	01	Pin BCLK1_GPI1 00: Disabled (Input powered down) 01: Input mode 10: Reserved 11: Reserved

**Book 0 / Page 1 / Register 78: Reserved Register - 0x00 / 0x01 / 0x4E (B0\_P1\_R78)**

BIT	FIELD	READ/ WRITE	RESET VALUE	DESCRIPTION
D7-D0	RESERVED	R	xxxx xxxx	Reserved

**Book 0 / Page 1 / Register 79: GPIO HIZ CTRL1 Register - 0x00 / 0x01 / 0x4F (B0\_P1\_R79)**

BIT	FIELD	READ/ WRITE	RESET VALUE	DESCRIPTION
D7-D5	RESERVED	R/W	000	Reserved. Write only reset values.
D4	GPIO2_HIZ	R/W	0	GPIO2 output 000: Drives both LO/HI 001: Drives both LO/HI with buskeeper(weak pull-up/down). For use with outputs that my be tri-stated such as TDM
D3-D1	RESERVED	R/W	000	Reserved. Write only reset values.
D0	GPIO1_HIZ	R/W	0	GPIO1 output 000: Drives both LO/HI 001: Drives both LO/HI with buskeeper(weak pull-up/down). For use with outputs that my be tri-stated such as TDM

**Book 0 / Page 1 / Register 80: GPIO HIZ CTRL2 Register - 0x00 / 0x01 / 0x50 (B0\_P1\_R80)**

BIT	FIELD	READ/ WRITE	RESET VALUE	DESCRIPTION
D7-D5	RESERVED	R/W	000	Reserved. Write only reset values.
D4	GPIO4_HIZ	R/W	0	GPIO4 output 000: Drives both LO/HI. 001: Drives both LO/HI with buskeeper(weak pull-up/down). For use with outputs that my be tri-stated such as TDM
D3-D1	RESERVED	R/W	000	Reserved. Write only reset values.
D0	GPIO3_HIZ	R/W	0	GPIO3 utput 000: Drives both LO/HI 001: Drives both LO/HI with buskeeper(weak pull-up/down). For use with outputs that my be tri-stated such as TDM

**Book 0 / Page 1 / Register 81: GPIO HIZ CTRL3 Register - 0x00 / 0x01 / 0x51 (B0\_P1\_R81)**

BIT	FIELD	READ/ WRITE	RESET VALUE	DESCRIPTION
D7-D5	RESERVED	R/W	000	Reserved. Write only reset values.
D4	GPIO6_HIZ	R/W	0	GPIO6 output 000: Drives both LO/HI 001: Drives both LO/HI with buskeeper(weak pull-up/down). For use with outputs that my be tri-stated such as TDM
D3-D1	RESERVED	R/W	000	Reserved. Write only reset values.
D0	GPIO5_HIZ	R/W	0	GPIO5 output 000: Drives both LO/HI 001: Drives both LO/HI with buskeeper(weak pull-up/down). For use with outputs that my be tri-stated such as TDM

**Book 0 / Page 1 / Register 82: GPIO HIZ CTRL4 Register - 0x00 / 0x01 / 0x52 (B0\_P1\_R82)**

BIT	FIELD	READ/ WRITE	RESET VALUE	DESCRIPTION
D7-D5	RESERVED	R/W	000	Reserved. Write only reset values.
D4	GPIO8_HIZ	R/W	0	GPIO8 output 000: Drives both LO/HI 001: Drives both LO/HI with buskeeper(weak pull-up/down). For use with outputs that my be tri-stated such as TDM
D3-D1	RESERVED	R/W	000	Reserved. Write only reset values.
D0	GPIO7_HIZ	R/W	0	GPIO7 output 000: Drives both LO/HI 001: Drives both LO/HI with buskeeper(weak pull-up/down). For use with outputs that my be tri-stated such as TDM

**Book 0 / Page 1 / Register 83: GPIO HIZ CTRL3 Register - 0x00 / 0x01 / 0x53 (B0\_P1\_R83)**

BIT		READ/ WRITE	RESET VALUE	DESCRIPTION
D7-D5	RESERVED	R/W	000	Reserved. Write only reset values.
D4	GPIO10_HIZ	R/W	0	GPIO10 output 000: Drives both LO/Hi 001: Drives both LO/Hi with buskeeper(weak pull-up/down). For use with outputs that my be tri-stated such as TDM
D3-D1	RESERVED	R/W	000	Reserved. Write only reset values.
D0	GPIO9_HIZ	R/W	0	GPIO9 output 000: Drives both LO/Hi 001: Drives both LO/Hi with buskeeper(weak pull-up/down). For use with outputs that my be tri-stated such as TDM

**Book 0 / Page 1 / Register 84-86: Reserved Registers - 0x00 / 0x01 / 0x54-0x56 (B0\_P1\_R84-86)**

BIT	FIELD	READ/ WRITE	RESET VALUE	DESCRIPTION
D7-D0	RESERVED	R	xxxx xxxx	Reserved.

**Book 0 / Page 1 / Register 87: GPIO Pin 1 Register - 0x00 / 0x01 / 0x57 (B0\_P1\_R87)**

BIT	FIELD	READ/ WRITE	RESET VALUE	DESCRIPTION
D7-D1	RESERVED	R/W	0000 000	Reserved. Write only reset values.
D0	GPO_BO_MODE	R/W	0	0: Use R88,R89 to directly drive output on respective pins 1: Use DSP port to drive outputs on respective pins

**Book 0 / Page 1 / Register 88: GPIO Pin 2 Register - 0x00 / 0x01 / 0x58 (B0\_P1\_R88)**

BIT	FIELD	READ/ WRITE	RESET VALUE	DESCRIPTION
D7	GPIO8_BOV	R/W	0	GPIO8 general purpose output value is 0: Low(0) 1: High(1)
D6	GPIO7_BOV	R/W	0	GPIO7 general purpose output value is 0: Low(0) 1: High(1)
D5	GPIO6_BOV	R/W	0	GPIO6 general purpose output value is 0: Low(0) 1: High(1)
D4	GPIO5_BOV	R/W	0	GPIO5 general purpose output value is 0: Low(0) 1: High(1)
D3	GPIO4_BOV	R/W	0	GPIO4 general purpose output value is 0: Low(0) 1: High(1)
D2	GPIO3_BOV	R/W	0	GPIO3 General Purpose Output Value 0: Low(0) 1: High(1)
D1	GPIO2_BOV	R/W	0	GPIO2 General Purpose Output Valuet 0: Low(0) 1: High(1)
D0	GPIO1_BOV	R/W	0	GPIO1 General Purpose Output Value 0: Low(0) 1: High(1)

**Book 0 / Page 1 / Register 89: GPIO Pin 3 Register - 0x00 / 0x01 / 0x59 (B0\_P1\_R89)**

BIT	FIELD	READ/ WRITE	RESET VALUE	DESCRIPTION
D7-D2	RESERVED	R/W	0000 00	Reserved. Write only reset values.
D1	GPIO10_BOV	R/W	0	GPIO10 general purpose output value is 0: Low(0) 1: High(1)
D0	GPIO9_BOV	R/W	0	GPIO9 general purpose output value is 0: Low(0) 1: High(1)

**Book 0 / Page 1 / Register 90-107: Reserved Registers - 0x00 / 0x01 / 0x5A-0x6B (B0\_P1\_R84-86)**

BIT	FIELD	READ/ WRITE	RESET VALUE	DESCRIPTION
D7-D0	RESERVED	R	xxxx xxxx	Reserved. Write only reset values.

**Book 0 / Page 1 / Register 108: Interrupt Control 1 Register - 0x00 / 0x01 / 0x6C (B0\_P1\_R108)**

BIT	FIELD	READ/ WRITE	RESET VALUE	DESCRIPTION
D7	RESERVED	R/W	0	Reserved. Write only reset values.
D6-D4	INT_OVER_I	R/W	000	Speaker over-current flag is 000: not used in the generation of pin interrupt 001: used in the generation of INT1 interrupt 010: used in the generation of INT2 interrupt 011: used in the generation of INT3 interrupt 100: used in the generation of INT4 interrupt 101-111: Reserved
D3	RESERVED	R/W	0	Reserved. Write only reset values.
D2-D0	INT_OVER_V	R/W	000	Speaker over-voltage flag is 000: not used in the generation of pin interrupt 001: used in the generation of INT1 interrupt 010: used in the generation of INT2 interrupt 011: used in the generation of INT3 interrupt 100: used in the generation of INT4 interrupt 101-111: Reserved

**Book 0 / Page 1 / Register 109: Interrupt Control 2 Register - 0x00 / 0x01 / 0x6D (B0\_P1\_R109)**

BIT	FIELD	READ/ WRITE	RESET VALUE	DESCRIPTION
D7	RESERVED	R/W	0	Reserved. Write only reset values.
D6-D4	INT_CLK_ERR1	R/W	000	Clock error detect 1 flag is 000: not used in the generation of pin Interrupt 001: used in the generation of INT1 Interrupt 010: used in the generation of INT2 Interrupt 011: used in the generation of INT3 Interrupt 100: used in the generation of INT4 Interrupt 101-111: Reserved
D3	RESERVED	R/W	0	Reserved. Write only reset values.
D2-D0	INT_OVER_TEMP	R/W	0	Over-temperature flag is 000: not used in the generation of pin Interrupt 001: used in the generation of INT1 interrupt 010: used in the generation of INT2 interrupt 011: used in the generation of INT3 interrupt 100: used in the generation of INT4 interrupt 101-111: Reserved

**Book 0 / Page 1 / Register 110: Interrupt Control 3 Register - 0x00 / 0x01 / 0x6E (B0\_P1\_R110)**

BIT	FIELD	READ/ WRITE	RESET VALUE	DESCRIPTION
D7	RESERVED	R/W	0	Reserved. Write only reset values.
D6-D4	INT_BROWNOUT	R/W	000	Brownout flag is 000: not used in the generation of pin Interrupt 001: used in the generation of INT1 Interrupt 010: used in the generation of INT2 Interrupt 011: used in the generation of INT3 Interrupt 100: used in the generation of INT4 Interrupt 101-111: Reserved
D3	RESERVED	R/W	0	Reserved. Write only reset values.
D2-D0	INT_CLK_ERR2	R/W	000	Clock error detect 2 flag is 000: not used in the generation of pin Interrupt 001: used in the generation of INT1 Interrupt 010: used in the generation of INT2 Interrupt 011: used in the generation of INT3 Interrupt 100: is used in the generation of INT4 Interrupt 101-111: Reserved

**Book 0 / Page 1 / Register 111: Interrupt Control 4 Register - 0x00 / 0x01 / 0x6F (B0\_P1\_R111)**

BIT	FIELD	READ/ WRITE	RESET VALUE	DESCRIPTION
D7	RESERVED	R/W	0	Reserved. Write only reset values.
D6-D4	INT_SAR_DONE	R/W	000	SAR complete flag is 000: not used in the generation of pin Interrupt 001: used in the generation of INT1 Interrupt 010: used in the generation of INT2 Interrupt 011: used in the generation of INT3 Interrupt 100: used in the generation of INT4 Interrupt 101-111: Reserved
D3-D0		R	xxx	Reserved. Write only reset values.

**Book 0 / Page 1 / Register 112: Interrupt Control 5 Register - 0x00 / 0x01 / 0x70 (B0\_P1\_R112)**

BIT	FIELD	READ/ WRITE	RESET VALUE	DESCRIPTION
D7	RESERVED	R/W	0	Reserved. Write only reset values.
D6-D4	INT_DSP1	R/W	000	DSP output interrupt 1 flag is 000: not used in the generation of pin Interrupt 001: used in the generation of INT1 Interrupt 010: used in the generation of INT2 Interrupt 011: used in the generation of INT3 Interrupt 100: used in the generation of INT4 Interrupt 101-111: Reserved
D3	RESERVED	R/W	0	Reserved. Write only reset values.
D2-D0	INT_DSP2	R/W	000	DSP output interrupt 2 flag is 000: not used in the generation of pin Interrupt 001: used in the generation of INT1 Interrupt 010: used in the generation of INT2 Interrupt 011: used in the generation of INT3 Interrupt 100: used in the generation of INT4 Interrupt 101-111: Reserved

**Book 0 / Page 1 / Register 113: Interrupt Control 6 Register - 0x00 / 0x01 / 0x71 (B0\_P1\_R113)**

BIT	FIELD	READ/ WRITE	RESET VALUE	DESCRIPTION
D7	RESERVED	R/W	0	Reserved. Write only reset values.

**Book 0 / Page 1 / Register 113: Interrupt Control 6 Register - 0x00 / 0x01 / 0x71 (B0\_P1\_R113) (continued)**

BIT	FIELD	READ/ WRITE	RESET VALUE	DESCRIPTION
D6-D4	INT_DSP3	R/W	000	DSP output interrupt 3 flag is 000: not used in the generation of pin Interrupt 001: used in the generation of INT1 Interrupt 010: used in the generation of INT2 Interrupt 011: used in the generation of INT3 Interrupt 100: used in the generation of INT4 Interrupt 101-111: Reserved
D3	RESERVED	R/W	0	Reserved. Write only reset values.
D2-D0	INT_DSP4	R/W	000	DSP output interrupt 4 flag is 000: not used in the generation of pin Interrupt 001: used in the generation of INT1 Interrupt 010: used in the generation of INT2 Interrupt 011: used in the generation of INT3 Interrupt 100: used in the generation of INT4 Interrupt 101-111: Reserved

**Book 0 / Page 1 / Register 114-127: Reserved Register - 0x00 / 0x01 / 0x72-0x7F (B0\_P1\_R127)**

BIT	FIELD	READ/ WRITE	RESET VALUE	DESCRIPTION
D7-D0	RESERVED	R	xxxx xxxx	Reserved

**13.4 Book 0 Page 2**
**Book 0 / Page 2 / Register 0: Page Select Register - 0x00 / 0x02 / 0x00 (B0\_P0\_R0)**

BIT	FIELD	READ/ WRITE	RESET VALUE	DESCRIPTION
D7-D0	PAGE	R/W	0000 0000	Page Select Register 0-255: Selects the Register Page for next read or write command. Refer Table for details.

**Book 0 / Page 2 / Register 1-5: Reserved Register - 0x00 / 0x02 / 0x01-0x05 (B0\_P1\_R1-5)**

BIT	FIELD	READ/ WRITE	RESET VALUE	DESCRIPTION
D7-D0	RESERVED	R	xxxx xxxx	Reserved

**Book 0 / Page 2 / Register 6: Ramp Generator Frequency Register - 0x00 / 0x02 / 0x06 (B0\_P2\_R6)**

BIT	FIELD	READ/ WRITE	RESET VALUE	DESCRIPTION
D7-D5	RESERVED	R/W	000	Reserved. Write only reset values.
D4	RAMP_FREQ	R/W	0	Ramp Generator Frequency 00: 384kHz ramp_sel_res_freq = 0), Use this for Fs of 48ksps and its multiples 01: 352.8kHz, Use this for Fs of 44.1ksps and its multiples
D3-D0	RESERVED	R/W	0000	Reserved. Write only reset values.

**Book 0 / Page 2 / Register 7-23: Reserved Register - 0x00 / 0x02 / 0x07-0x17 (B0\_P1\_R7-23)**

BIT	FIELD	READ/ WRITE	RESET VALUE	DESCRIPTION
D7-D0	RESERVED	R	xxxx xxxx	Reserved

**Book 0 / Page 2 / Register 24: Inrush Optimization 1 Register - 0x00 / 0x02 / 0x18 (B0\_P2\_R24)**

BIT	FIELD	READ/ WRITE	RESET VALUE	DESCRIPTION
D7-D6	RESERVED	R/W	00	Reserved. Write only reset values.
D5-D3	INRUSH1	R/W	101	Inrush Current Optimization 1 000: Class-H operation inrush current optimization for boost 101 Not Recommended Other: Reserved
D2-D0	INRUSH2	R/W	101	Inrush Current Optimization 2 000: Class-H operation inrush current optimization for boost 101 Not Recommended Other: Reserved

**Book 0 / Page 2 / Register 25: Inrush Optimization 2 Register - 0x00 / 0x02 / 0x19 (B0\_P2\_R25)**

BIT	FIELD	READ/ WRITE	RESET VALUE	DESCRIPTION
D7-D6	RESERVED	R/W	00	Reserved. Write only reset values.
D5-D3	INRUSH3	R/W	101	Inrush Current Optimization 3 000: Class-H operation inrush current optimization for boost 101 Not Recommended Other: Reserved
D2-D0	INRUSH4	R/W	101	Inrush Current Optimization 4 000: Class-H operation inrush current optimization for boost 101 Not Recommended Other: Reserved

**Book 0 / Page 2 / Register 26: Inrush Optimization 3 Register - 0x00 / 0x02 / 0x1A (B0\_P2\_R25)**

BIT	FIELD	READ/ WRITE	RESET VALUE	DESCRIPTION
D7-D6	RESERVED	R/W	00	Reserved. Write only reset values.
D5-D3	INRUSH5	R/W	101	Inrush Current Optimization 5 000: Class-H operation inrush current optimization for boost 101 Not Recommended Other: Reserved
D2-D0	INRUSH6	R/W	101	Inrush Current Optimization 6 000: Class-H operation inrush current optimization for boost 101 Not Recommended Other: Reserved

**Book 0 / Page 2 / Register 27: Inrush Optimization 4 Register - 0x00 / 0x02 / 0x1B (B0\_P2\_R25)**

BIT	FIELD	READ/ WRITE	RESET VALUE	DESCRIPTION
D7-D6	RESERVED	R/W	00	Reserved. Write only reset values.
D5-D3	INRUSH7	R/W	101	Inrush Current Optimization 7 000: Class-H operation inrush current optimization for boost 101 Not Recommended Other: Reserved
D2-D0	INRUSH8	R/W	101	Inrush Current Optimization 8 000: Class-H operation inrush current optimization for boost 101 Not Recommended Other: Reserved

**Book 0 / Page 2 / Register 28-127: Reserved Register - 0x00 / 0x02 / 0x1C-0x7F (B0\_P1\_R28-127)**

BIT	FIELD	READ/ WRITE	RESET VALUE	DESCRIPTION
D7-D0	RESERVED	R	xxxx xxxx	Reserved

**13.5 Book 100 Page 0**
**Book 100 / Page 0 / Register 0: Page Select Register - 0x64 / 0x00 / 0x00 (B100\_P0\_R0)**

BIT	FIELD	READ/ WRITE	RESET VALUE	DESCRIPTION
D7-D0	PAGE	R/W	0000 0000	Page Select Register 0-255: Selects the Register Page for next read or write command. Refer Table for details.

**Book 100 / Page 0 / Register 1: DAC Interpolation Register - 0x64 / 0x00 / 0x01 (B100\_P0\_R1)**

BIT	FIELD	READ/ WRITE	RESET VALUE	DESCRIPTION
D7-D0	DAC_RATIO	R/W	0000 1000	DAC Interpolation ratio outside DSP is 0000 0000: 256 0000 0001: 1 0000 0001: 2 ... 1111 1110: 254 1111 1111: 255

**Book 100 / Page 0 / Register 2: ADC interpolation Register - 0x64 / 0x00 / 0x01 (B100\_P0\_R1)**

BIT	FIELD	READ/ WRITE	RESET VALUE	DESCRIPTION
D7-D6	RESERVED	R/W	00	Reserved. Write only reset values.
D5-D0	ADC_RATIO	R/W	00 0000	ADC interpolation ratio outside DSP is 00 0000: 64 00 0001: 1 00 0001: 2 ... 10 0101: 37 10 0110: 38 (maximum ratio supported for Isense/Vsense) 10 0111: 39 (supported only for PDM audio input) 10 1000: 40 (supported only for PDM audio input) 10 1001: 41 (supported only for PDM audio input) 10 1010: 42 (supported only for PDM audio input) 10 1011: 43 (supported only for PDM audio input) 10 1100: 44 (supported only for PDM audio input) 10 1101: 45 (supported only for PDM audio input)

**Book 100 / Page 0 / Register 3-6: Reserved Register - 0x64 / 0x00 / 0x03-0x06 (B100\_P0\_R3-6)**

BIT	FIELD	READ/ WRITE	RESET VALUE	DESCRIPTION
D7-D0	RESERVED	R	xxxx xxxx	Reserved.

**Book 100 / Page 0 / Register 7: DSP Mute Register - 0x64 / 0x00 / 0x07 (B100\_P0\_R7)**

BIT	FIELD	READ/ WRITE	RESET VALUE	DESCRIPTION
D7-D4	RESERVED	R/W	0000	Reserved. Write only reset values.
D3	PDM_MUTE	R/W	1	PDM soft mute is 0: un-mute 1: mute
D2	VSNS_MUTE	R/W	1	Vsense soft mute is 0: un-mute 1: mute
D1	ISNS_MUTE	R/W	1	Isense soft mute is 0: un-mute 1: mute

**Book 100 / Page 0 / Register 7: DSP Mute Register - 0x64 / 0x00 / 0x07 (B100\_P0\_R7) (continued)**

BIT	FIELD	READ/ WRITE	RESET VALUE	DESCRIPTION
D0	SPK_MUTE	R/W	1	Class-D soft mute is 0: un-mute 1: mute

**Book 100 / Page 0 / Register 8-15: Reserved Register - 0x64 / 0x00 / 0x08-0x0F (B100\_P0\_R8-15)**

BIT	FIELD	READ/ WRITE	RESET VALUE	DESCRIPTION
D7-D0	RESERVED	R	xxxx xxxx	Reserved

**Book 100 / Page 0 / Register 16: Interrupt 1 DSP Register - 0x64 / 0x00 / 0x10 (B100\_P0\_R16)**

BIT	FIELD	READ/ WRITE	RESET VALUE	DESCRIPTION
D7	INT1_POL	R/W	0	ISR1 interrupt polarity is 0: Active High 1: Active Low
D6	INT1_TRG	R/W	0	ISR1 interrupt is 0: Level sensitive 1: Edge sensitive
D4-D0	INT1_PATH	R/W	00000	ISR1 interrupt input to DSP is 0 0000: disabled 0 0001: GPIO1 0 0010: GPIO2 0 0011: GPIO3 0 0100: GPIO4 0 0101: GPIO5 0 0110: GPIO6 0 0111: GPIO7 0 1000: GPIO8 0 1001: GPIO9 0 1010: GPIO10 0 1011: Reserved 0 1100: Reserved 0 1101: GPI1 0 1110: GPI2 0 1111: GPI3 others: Reserved

**Book 100 / Page 0 / Register 17: Interrupt 2 DSP Register - 0x64 / 0x00 / 0x11 (B100\_P0\_R17)**

BIT	FIELD	READ/ WRITE	RESET VALUE	DESCRIPTION
D7	INT2_POL	R/W	0	ISR2 interrupt polarity is 0: Active high 1: Active low
D6	INT2_TRG	R/W	0	ISR2 interrupt is 0: Level sensitive 1: Edge sensitive

**Book 100 / Page 0 / Register 17: Interrupt 2 DSP Register - 0x64 / 0x00 / 0x11 (B100\_P0\_R17) (continued)**

BIT	FIELD	READ/ WRITE	RESET VALUE	DESCRIPTION
D4-D0	INT2_PATH	R/W	00000	ISR2 interrupt input to DSP is 0 0000: disabled 0 0001: GPIO1 0 0010: GPIO2 0 0011: GPIO3 0 0100: GPIO4 0 0101: GPIO5 0 0110: GPIO6 0 0111: GPIO7 0 1000: GPIO8 0 1001: GPIO9 0 1010: GPIO10 0 1011: Reserved 0 1100: Reserved 0 1101: GPI1 0 1110: GPI2 0 1111: GPI3 others: Reserved

**Book 100 / Page 0 / Register 18: Condition 1 DSP Register - 0x64 / 0x00 / 0x12 (B100\_P0\_R18)**

BIT	FIELD	READ/ WRITE	RESET VALUE	DESCRIPTION
D7	COND1_POL	R/W	0	COND1 interrupt polarity is 0: Active high 1: Active low
D6	COND1_TRG	R/W	0	COND1 interrupt is 0: Level sensitive 1: Edge sensitive
D4-D0	COND1_PATH	R/W	00000	COND1 interrupt input to DSP is 0 0000: disabled 0 0001: GPIO1 0 0010: GPIO2 0 0011: GPIO3 0 0100: GPIO4 0 0101: GPIO5 0 0110: GPIO6 0 0111: GPIO7 0 1000: GPIO8 0 1001: GPIO9 0 1010: GPIO10 0 1011: Reserved 0 1100: Reserved 0 1101: GPI1 0 1110: GPI2 0 1111: GPI3 others: Reserved

**Book 100/ Page 0 / Register 19: Condition 2 DSP Register - 0x64 / 0x00 / 0x13 (B100\_P0\_R19)**

BIT	FIELD	READ/ WRITE	RESET VALUE	DESCRIPTION
D7	COND2_POL	R/W	0	COND2 interrupt polarity is 0: Active High 1: Active Low
D6	COND2_TRG	R/W	0	COND2 interrupt is 0: Level Sensitive 1: Edge Sensitive

**Book 100/ Page 0 / Register 19: Condition 2 DSP Register - 0x64 / 0x00 / 0x13 (B100\_P0\_R19) (continued)**

BIT	FIELD	READ/ WRITE	RESET VALUE	DESCRIPTION
D4-D0	COND2_PATH	R/W	00000	COND2 Interrupt Input to DSP 0 0000: disabled 0 0001: GPIO1 0 0010: GPIO2 0 0011: GPIO3 0 0100: GPIO4 0 0101: GPIO5 0 0110: GPIO6 0 0111: GPIO7 0 1000: GPIO8 0 1001: GPIO9 0 1010: GPIO10 0 1011: Reserved 0 1100: Reserved 0 1101: GPI1 0 1110: GPI2 0 1111: GPI3 others: Reserved

**Book 100 / Page 0 / Register 20: ISR and COND Control Register - 0x64 / 0x00 / 0x14 (B100\_P0\_R20)**

BIT	FIELD	READ/ WRITE	RESET VALUE	DESCRIPTION
D7	DSP_ISR3	R/W	0	ISR3 interrupt input to DSP is 0: Low 1: High
D6	DSP_ISR4	R/W	0	ISR4 interrupt input to DSP is 0: Low 1: High
D5-D4	RESERVED	R/W	00	Reserved. Write only reset values.
D3	DSP_COND3	R/W	0	COND3 interrupt input to DSP is 0: Low 1: High
D2	DSP_COND4			COND4 interrupt input to DSP is 0: Low 1: High
D1-D0	RESERVED	R/W	00	Reserved. Write only reset values.

**Book 100 / Page 0/ Register 21: DSP Control Register - 0x64 / 0x00 / 0x15 (B100\_P0\_R21)**

BIT	FIELD	READ/ WRITE	RESET VALUE	DESCRIPTION
D7	RESERVED	R/W	0	Reserved. Write only reset values.
D6	DSP_SPI_DLY	R/W	0	0: SPI read will have one frame (8-bit) delay while reading RAMs. 1: SPI read will always have one frame (8-bit) delay
D5	DSP_APAGE	R/W	0	Auto increment page for non-zero book is 0: Enable 1: Disable
D4-D0	RESERVED	R/W	0 0000	Reserved. Write only reset values.

**Book 100 / Page 0 / Register 22-26: Reserved Register - 0x64 / 0x00 / 0x16-0x1A (B100\_P0\_R22-26)**

BIT	FIELD	READ/ WRITE	RESET VALUE	DESCRIPTION
D7-D0	RESERVED	R	xxxx xxxx	Reserved

**Book 100 / Page 0 / Register 27:PLL CLKIN Divider Register - 0x64 / 0x00 / 0x1B (B100\_P0\_R27)**

BIT	FIELD	READ/ WRITE	RESET VALUE	DESCRIPTION
D7-D6	RESERVED	R/W	00	Reserved. Write only reset values.
D5-D0	PLL_PDIV	R/W	00 0001	PLL_CLKIN divider (generates input clock for PLL P-divider) is 00 0000: 64 00 0001: 1 00 0001: 2 ... 11 1110: 62 11 1111: 63

**Book 100 / Page 0 / Register 28:PLL J-VAL Divider Register - 0x64 / 0x00 / 0x1C (B100\_P0\_R28)**

BIT	FIELD	READ/ WRITE	RESET VALUE	DESCRIPTION
D7	PLL_LOW	R/W	0	PLL low input frequency is 0: should be set when PLL CLKIN divider output is greater than 1MHz 1: should be set when PLL CLKIN divider output is less than 1MHz
D6-D0	PLL_JDIV	R/W	00 0100	PLL J multiplier is 00 0000: Reserved 00 0001: 1 00 0010: 2 ... 11 1110: 62 11 1111: 63

**Book 100 / Page 0 / Register 29:PLL D-VAL Divider 2 Register - 0x64 / 0x00 / 0x1D (B100\_P0\_R29)**

BIT	FIELD	READ/ WRITE	RESET VALUE	DESCRIPTION
D7	RESERVED	R/W	0	Reserved. Write only reset values.
D6-D0	PLL_DVAL2	R/W	000 0000	PLL D Fractional Multiplier D(13:8)

**Book 100 / Page 0 / Register 30:PLL D-VAL Divider 1 Register - 0x64 / 0x00 / 0x1E (B100\_P0\_R30)**

BIT	FIELD	READ/ WRITE	RESET VALUE	DESCRIPTION
D7-D0	PLL_DVAL1	R/W	0000 0000	PLL D Fractional Multiplier D(7:0)

**Book 100 / Page 0 / Register 31:DSP Clock Register - 0x64 / 0x00 / 0x1F (B100\_P0\_R31)**

BIT	FIELD	READ/ WRITE	RESET VALUE	DESCRIPTION
D7-D6	RESERVED	R/W	00	Reserved. Write only reset values.
D5	DSP_CLK	R/W	0	DSP clock is generated from 0: output of N_VAL divider in B100_P0_R32 1: directly from PLL Clock
D4-D3	MDAC_CLK	R/W	00	MDAC and MADC is clock divider input is 00: NDIV_CLK (N-divider output) 01: MCLK_GPI2. This can be used only if MCLK is multiple of 8*64*Fs or 4*64*Fs(with 48-52% duty-cycle) 10: ICC_GPIO9. This can be used only if MCLK is multiple of 8*64*Fs or 4*64*Fs(with 48-52% duty-cycle) 11: Reserved
D2-D1	BOOST_CLK	R/W	00	Boost and Charge-pump divider input is 00: NDIV_CLK (N-divider output) 01: MCLK_GPI2. 10: ICC_GPIO9. 11: Reserved
D0	RESERVED	R/W	0	Reserved. Write only reset values.

**Book 100 / Page 0 / Register 32: N-VAL Divider Register - 0x64 / 0x00 / 0x20 (B100\_P0\_R32)**

BIT	FIELD	READ/ WRITE	RESET VALUE	DESCRIPTION
D7-D0	N_DIV	R/W	0000 0001	N divider is 0000 0000: 128 0000 0001: 1 0000 0010: 2 ... 1111 1110: 126 1111 1111: 127

**Book 100 / Page 0 / Register 33: MDAC-VAL Divider Register - 0x64 / 0x00 / 0x21 (B100\_P0\_R33)**

BIT	FIELD	READ/ WRITE	RESET VALUE	DESCRIPTION
D7-D0	MDAC_DIV	R/W	0000 0100	DAC divider is 0000 0000: 128 0000 0001: 1 0000 0010: 2 ... 1111 1110: 126 1111 1111: 127

**Book 100 / Page 0 / Register 34: MADC-VAL Divider Register - 0x64 / 0x00 / 0x22 (B100\_P0\_R34)**

BIT	FIELD	READ/ WRITE	RESET VALUE	DESCRIPTION
D7	RESERVED	R/W	00	Reserved. Write only reset values.
D6-D3	MADC_DIV_PRE	R/W	0001	ADC Divider pre is 0000: 16 0001: 1 0010: 2 ... 1110: 14 1111: 15
D2-D0	MADC_DIV_FIN	R/W	000	ADC divider final (this divider configuration is used only if B100_P0_R42[7:6]=11) is 000: 8 001: 1 010: 2 ... 110: 6 111: 7

**Book 100 / Page 0 / Register 35-37: Reserved Register - 0x64 / 0x00 / 0x23-0x25 (B100\_P0\_R35-37)**

BIT	FIELD	READ/ WRITE	RESET VALUE	DESCRIPTION
D7-D0	RESERVED	R	xxxx xxxx	Reserved

**Book 100 / Page 0 / Register 38: Charge-pump Clock Register - 0x64 / 0x00 / 0x26 (B100\_P0\_R38)**

BIT	FIELD	READ/ WRITE	RESET VALUE	DESCRIPTION
D7	CP_CLK_GEN	R/W	0	Charge pump clock generation is 0: Use internally generated oscillator clock 1: Use NDIV_CLK/MCLK_GPIO2/ICC_GPIO9
D6-D5	RESERVED	R/W	00	Reserved. Write only reset values.

**Book 100 / Page 0 / Register 38: Charge-pump Clock Register - 0x64 / 0x00 / 0x26  
(B100\_P0\_R38) (continued)**

BIT	FIELD	READ/ WRITE	RESET VALUE	DESCRIPTION
D4-D0	CP_CLK_DIV	R/W	0010	Charge pump clock divider factor is 0 0000: 32 0 0001: 1 0 0010: 2 ... 1 1110: 30 1 1111: 31

**Book 100 / Page 0 / Register 39: Boost Clock Register - 0x64 / 0x00 / 0x27 (B100\_P0\_R39)**

BIT	FIELD	READ/ WRITE	RESET VALUE	DESCRIPTION
D7	RMP_CLK_GEN	R/W	0	Boost clock generation uses 0: internally generated oscillator clock 1: NDIV_CLK/MCLK_GPI2/ICC_GPIO9
D6-D3	BST_DIV_PRE	R/W	0010	Boost clock pre divider factor is 0000: 16 0001: 1 0010: 2 ... 1110: 14 1111: 15
D2-D0	BST_DIV_FIN	R/W	011	ADC divider final (this divider configuration is used only if B100_P0_R42[7:6]=11) is 000: 8 001: 1 010: 2 ... 110: 6 111: 7

**Book 100 / Page 0 / Register 40: Ramp Clock 1 Register - 0x64 / 0x00 / 0x28 (B100\_P0\_R40)**

BIT	FIELD	READ/ WRITE	RESET VALUE	DESCRIPTION
D7	RMP_CLK_GEN	R/W	0	Ramp clock generation is 0: internally generated 1: from DAC modulator clock (Refer to divider settings in B100_P0_R43-44)
D6-D0	RESERVED	R/W	000 0000	Reserved. Write only reset values.

**Book 100 / Page 0 / Register 41-42: Reserved Register - 0x64 / 0x00 / 0x29-0x2A (B100\_P0\_R41-42)**

BIT	FIELD	READ/ WRITE	RESET VALUE	DESCRIPTION
D7-D0	RESERVED	R	xxxx xxxx	Reserved.

**Book 100 / Page 0 / Register 43: Ramp Clock 2 Register - 0x64 / 0x00 / 0x2B (B100\_P0\_R43)**

BIT	FIELD	READ/ WRITE	RESET VALUE	DESCRIPTION
D7-D3	RESERVED	R/W	0000 0	Reserved. Write only reset values.
D2-D0	RMP_CLK_MSB	R/W	000	Ramp Clock Divider [10:8]

**Book 100 / Page 0 / Register 44: Ramp Clock 3 Register - 0x64 / 0x00 / 0x2C (B100\_P0\_R44)**

BIT	FIELD	READ/ WRITE	RESET VALUE	DESCRIPTION
D7-D0	RMP_CLK_LSB	R/W	000	Ramp Clock Divider [7:0]

**Book 100 / Page 0 / Register 45-126: Reserved Register - 0x64 / 0x01 / 0x2D-0x7E (B100\_P0\_R45-126)**

BIT	FIELD	READ/ WRITE	RESET VALUE	DESCRIPTION
D7-D0	RESERVED	R	xxxx xxxx	Reserved.

**Book 100 / Page 0 / Register 127: Book Selection Register - 0x64 / 0x00 / 0x7F (B100\_P0\_R127)**

BIT	FIELD	READ/ WRITE	RESET VALUE	DESCRIPTION
D7-D0	BOOK	R/W	0110 0100	0-255: Selects the Register Book for next read or write command.

## 14 Device and Documentation Support

### 14.1 Documentation Support

### 14.2 Community Resources

The following links connect to TI community resources. Linked contents are provided "AS IS" by the respective contributors. They do not constitute TI specifications and do not necessarily reflect TI's views; see TI's [Terms of Use](#).

**TI E2E™ Online Community** *TI's Engineer-to-Engineer (E2E) Community*. Created to foster collaboration among engineers. At [e2e.ti.com](http://e2e.ti.com), you can ask questions, share knowledge, explore ideas and help solve problems with fellow engineers.

**Design Support** *TI's Design Support* Quickly find helpful E2E forums along with design support tools and contact information for technical support.

### 14.3 Trademarks

PurePath, E2E are trademarks of Texas Instruments.  
All other trademarks are the property of their respective owners.

### 14.4 Electrostatic Discharge Caution



These devices have limited built-in ESD protection. The leads should be shorted together or the device placed in conductive foam during storage or handling to prevent electrostatic damage to the MOS gates.

### 14.5 Glossary

[SLYZ022](#) — *TI Glossary*.

This glossary lists and explains terms, acronyms, and definitions.

## 15 Mechanical, Packaging, and Orderable Information

The following pages include mechanical, packaging, and orderable information. This information is the most current data available for the designated devices. This data is subject to change without notice and revision of this document. For browser-based versions of this data sheet, refer to the left-hand navigation.

### 15.1 Package Dimensions

The TAS2555 uses a 42-ball, 0.5-mm pitch DSBGA package.



**Package Dimensions (continued)**

TAS255xYZ, SN\_\_\_\_255xYZ  
**YZ0042-C01**

**EXAMPLE BOARD LAYOUT**

**DSBGA - 0.625 mm max height**

DIE SIZE BALL GRID ARRAY

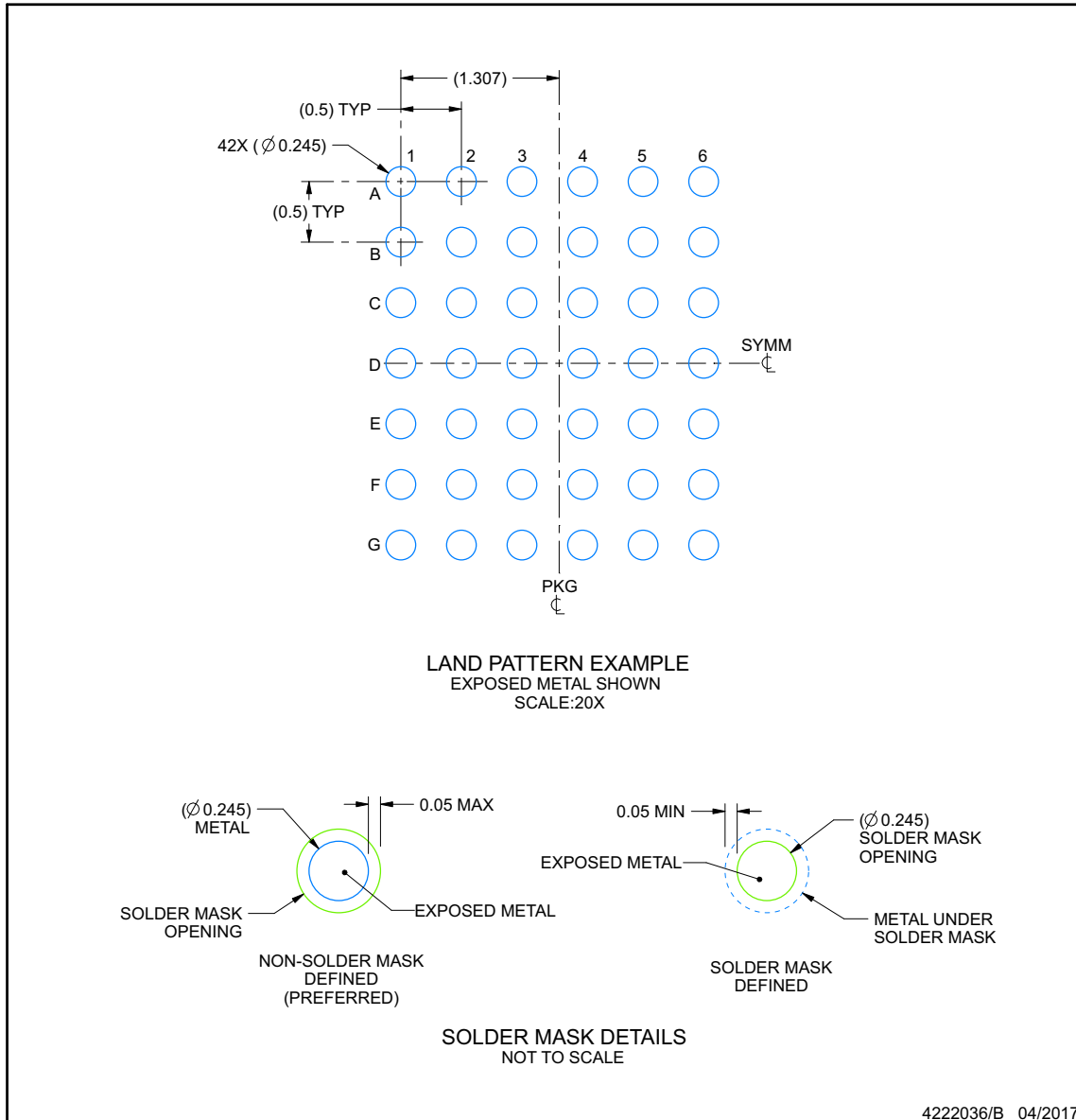

NOTES: (continued)

- Final dimensions may vary due to manufacturing tolerance considerations and also routing constraints. For more information, see Texas Instruments literature number SNVA009 ([www.ti.com/lit/snva009](http://www.ti.com/lit/snva009)).

**Package Dimensions (continued)**

TAS255xYZ, SN\_\_\_\_255xYZ

**EXAMPLE STENCIL DESIGN**

**YZ0042-C01**

**DSBGA - 0.625 mm max height**

DIE SIZE BALL GRID ARRAY

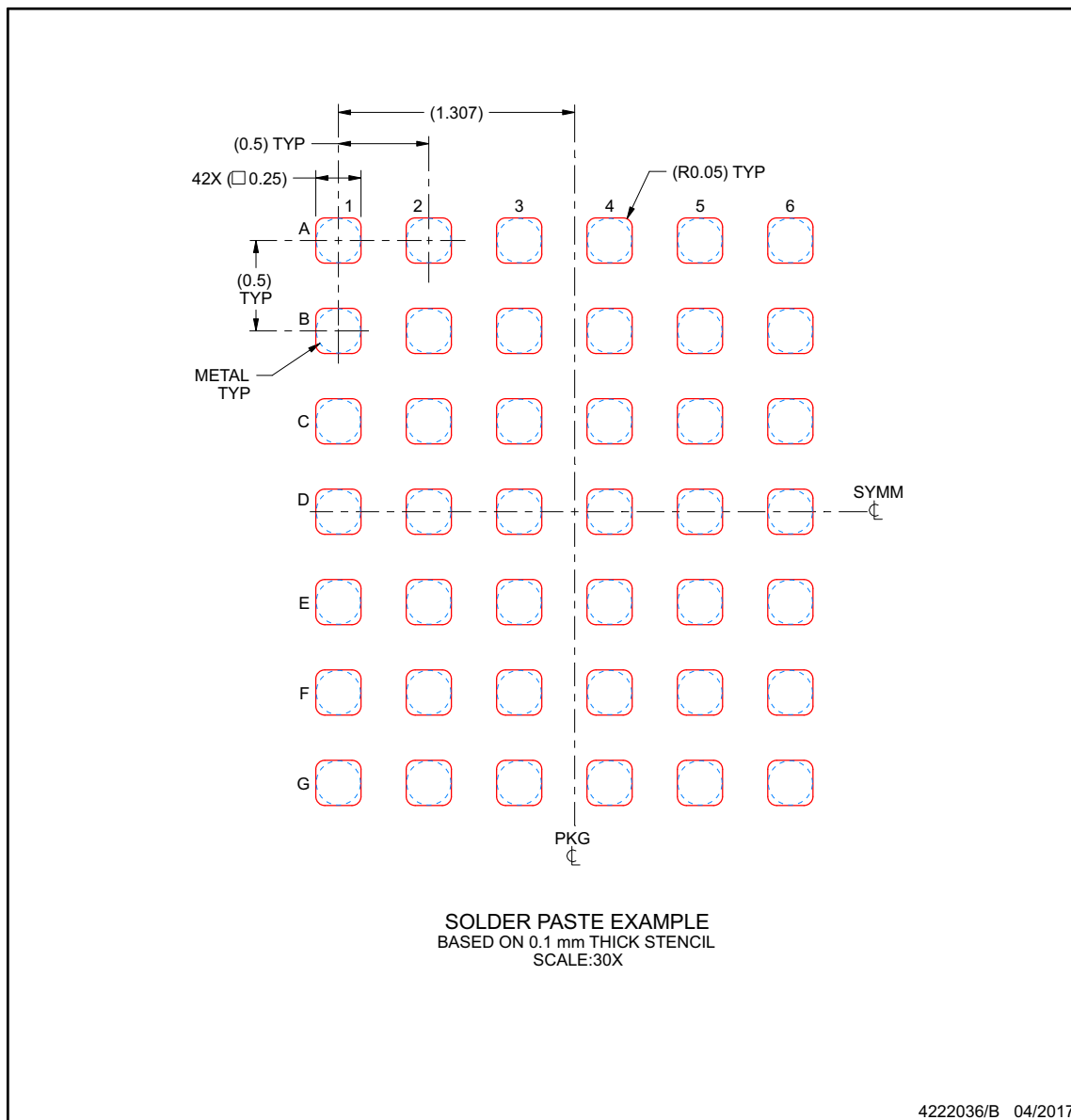

NOTES: (continued)

- 4. Laser cutting apertures with trapezoidal walls and rounded corners may offer better paste release.

**PACKAGING INFORMATION**

Orderable Device	Status (1)	Package Type	Package Drawing	Pins	Package Qty	Eco Plan (2)	Lead/Ball Finish (6)	MSL Peak Temp (3)	Op Temp (°C)	Device Marking (4/5)	Samples
TAS2555YZR	ACTIVE	DSBGA	YZ	42	3000	Green (RoHS & no Sb/Br)	SNAGCU	Level-1-260C-UNLIM	-40 to 85	2555	<a href="#">Samples</a>
TAS2555YZT	ACTIVE	DSBGA	YZ	42	250	Green (RoHS & no Sb/Br)	SNAGCU	Level-1-260C-UNLIM	-40 to 85	2555	<a href="#">Samples</a>

(1) The marketing status values are defined as follows:

**ACTIVE:** Product device recommended for new designs.

**LIFEBUY:** TI has announced that the device will be discontinued, and a lifetime-buy period is in effect.

**NRND:** Not recommended for new designs. Device is in production to support existing customers, but TI does not recommend using this part in a new design.

**PREVIEW:** Device has been announced but is not in production. Samples may or may not be available.

**OBsolete:** TI has discontinued the production of the device.

(2) **RoHS:** TI defines "RoHS" to mean semiconductor products that are compliant with the current EU RoHS requirements for all 10 RoHS substances, including the requirement that RoHS substance do not exceed 0.1% by weight in homogeneous materials. Where designed to be soldered at high temperatures, "RoHS" products are suitable for use in specified lead-free processes. TI may reference these types of products as "Pb-Free".

**RoHS Exempt:** TI defines "RoHS Exempt" to mean products that contain lead but are compliant with EU RoHS pursuant to a specific EU RoHS exemption.

**Green:** TI defines "Green" to mean the content of Chlorine (Cl) and Bromine (Br) based flame retardants meet JS709B low halogen requirements of <=1000ppm threshold. Antimony trioxide based flame retardants must also meet the <=1000ppm threshold requirement.

(3) MSL, Peak Temp. - The Moisture Sensitivity Level rating according to the JEDEC industry standard classifications, and peak solder temperature.

(4) There may be additional marking, which relates to the logo, the lot trace code information, or the environmental category on the device.

(5) Multiple Device Markings will be inside parentheses. Only one Device Marking contained in parentheses and separated by a "~" will appear on a device. If a line is indented then it is a continuation of the previous line and the two combined represent the entire Device Marking for that device.

(6) Lead/Ball Finish - Orderable Devices may have multiple material finish options. Finish options are separated by a vertical ruled line. Lead/Ball Finish values may wrap to two lines if the finish value exceeds the maximum column width.

**Important Information and Disclaimer:**The information provided on this page represents TI's knowledge and belief as of the date that it is provided. TI bases its knowledge and belief on information provided by third parties, and makes no representation or warranty as to the accuracy of such information. Efforts are underway to better integrate information from third parties. TI has taken and continues to take reasonable steps to provide representative and accurate information but may not have conducted destructive testing or chemical analysis on incoming materials and chemicals. TI and TI suppliers consider certain information to be proprietary, and thus CAS numbers and other limited information may not be available for release.

In no event shall TI's liability arising out of such information exceed the total purchase price of the TI part(s) at issue in this document sold by TI to Customer on an annual basis.

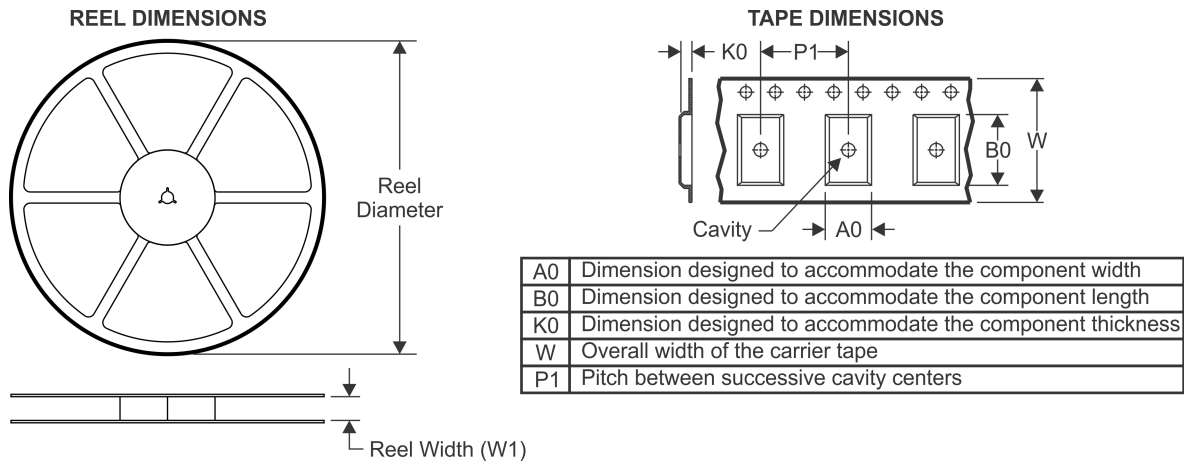
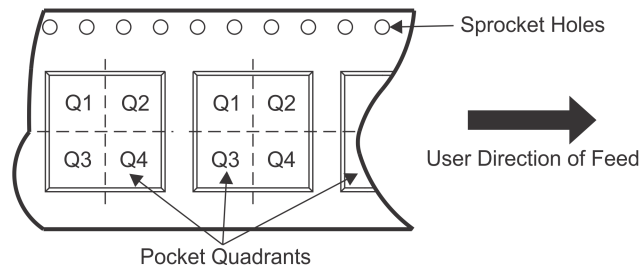

**TAPE AND REEL INFORMATION**

**QUADRANT ASSIGNMENTS FOR PIN 1 ORIENTATION IN TAPE**

\*All dimensions are nominal

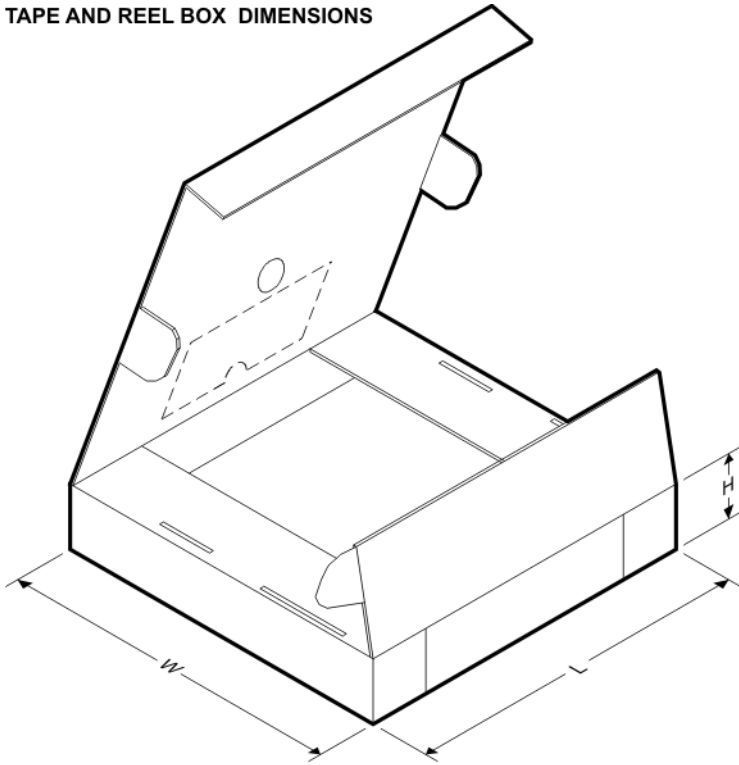
Device	Package Type	Package Drawing	Pins	SPQ	Reel Diameter (mm)	Reel Width W1 (mm)	A0 (mm)	B0 (mm)	K0 (mm)	P1 (mm)	W (mm)	Pin1 Quadrant
TAS2555YZR	DSBGA	YZ	42	3000	330.0	12.4	3.4	3.75	0.82	8.0	12.0	Q1
TAS2555YZT	DSBGA	YZ	42	250	330.0	12.4	3.4	3.75	0.82	8.0	12.0	Q1

**TAPE AND REEL BOX DIMENSIONS**

\*All dimensions are nominal

Device	Package Type	Package Drawing	Pins	SPQ	Length (mm)	Width (mm)	Height (mm)
TAS2555YZR	DSBGA	YZ	42	3000	367.0	367.0	35.0
TAS2555YZT	DSBGA	YZ	42	250	367.0	367.0	35.0

## IMPORTANT NOTICE AND DISCLAIMER

TI PROVIDES TECHNICAL AND RELIABILITY DATA (INCLUDING DATASHEETS), DESIGN RESOURCES (INCLUDING REFERENCE DESIGNS), APPLICATION OR OTHER DESIGN ADVICE, WEB TOOLS, SAFETY INFORMATION, AND OTHER RESOURCES "AS IS" AND WITH ALL FAULTS, AND DISCLAIMS ALL WARRANTIES, EXPRESS AND IMPLIED, INCLUDING WITHOUT LIMITATION ANY IMPLIED WARRANTIES OF MERCHANTABILITY, FITNESS FOR A PARTICULAR PURPOSE OR NON-INFRINGEMENT OF THIRD PARTY INTELLECTUAL PROPERTY RIGHTS.

These resources are intended for skilled developers designing with TI products. You are solely responsible for (1) selecting the appropriate TI products for your application, (2) designing, validating and testing your application, and (3) ensuring your application meets applicable standards, and any other safety, security, or other requirements. These resources are subject to change without notice. TI grants you permission to use these resources only for development of an application that uses the TI products described in the resource. Other reproduction and display of these resources is prohibited. No license is granted to any other TI intellectual property right or to any third party intellectual property right. TI disclaims responsibility for, and you will fully indemnify TI and its representatives against, any claims, damages, costs, losses, and liabilities arising out of your use of these resources.

TI's products are provided subject to TI's Terms of Sale ([www.ti.com/legal/termsofsale.html](http://www.ti.com/legal/termsofsale.html)) or other applicable terms available either on [ti.com](http://ti.com) or provided in conjunction with such TI products. TI's provision of these resources does not expand or otherwise alter TI's applicable warranties or warranty disclaimers for TI products.

Mailing Address: Texas Instruments, Post Office Box 655303, Dallas, Texas 75265  
Copyright © 2019, Texas Instruments Incorporated

## Looking for pricing, stock, or lifecycle information?

Click below to explore more details on WIN SOURCE:

 [View TAS2555YZT on WIN SOURCE](#)

 [Texas Instruments](#) Information

## Optimize Your Supply Chain with WIN SOURCE Solutions

-  Global Sourcing Solution
-  Obsolete Management
-  Cost Control Management
-  Shortage Management
-  Alternative Solution
-  Excess Inventory Management