



**THE DATASHEET OF
SN74ALS299DWR**



SN54ALS299, SN74ALS299 8-BIT UNIVERSAL SHIFT/STORAGE REGISTERS WITH 3-STATE OUTPUTS

SDAS220B – DECEMBER 1982 – REVISED DECEMBER 1994

- **Multiplexed I/O Ports Provide Improved Bit Density**
- **Four Modes of Operation:**
 - Hold (Store)
 - Shift Right
 - Shift Left
 - Load Data
- **Operate With Outputs Enabled or at High Impedance**
- **3-State Outputs Drive Bus Lines Directly**
- **Can Be Cascaded for n-Bit Word Lengths**
- **Direct Overriding Clear**
- **Applications:**
 - Stacked or Push-Down Registers
 - Buffer Storage
 - Accumulator Registers
- **Package Options Include Plastic Small-Outline (DW) Packages, Ceramic Chip Carriers (FK), and Standard Plastic (N) and Ceramic (J) 300-mil DIPs**

description

These 8-bit universal shift/storage registers feature multiplexed I/O ports to achieve full 8-bit data handling in a single 20-pin package. Two function-select (S_0 , S_1) inputs and two output-enable ($\overline{OE1}$, $\overline{OE2}$) inputs can be used to choose the modes of operation listed in the function table.

Synchronous parallel loading is accomplished by taking both S_0 and S_1 high. This places the 3-state outputs in the high-impedance state and permits data applied on the I/O ports to be clocked into the register. Reading out of the register can be accomplished while the outputs are enabled in any mode. Clearing occurs asynchronously when the clear (\overline{CLR}) input is low. Taking either $\overline{OE1}$ or $\overline{OE2}$ high disables the outputs, but has no effect on clearing, shifting, or storing data.

The SN54ALS299 is characterized for operation over the full military temperature range of -55°C to 125°C . The SN74ALS299 is characterized for operation from 0°C to 70°C .

SN54ALS299 . . . J PACKAGE
SN74ALS299 . . . DW OR N PACKAGE
(TOP VIEW)

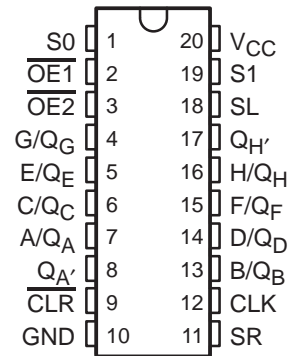

SN54ALS299 . . . FK PACKAGE
(TOP VIEW)

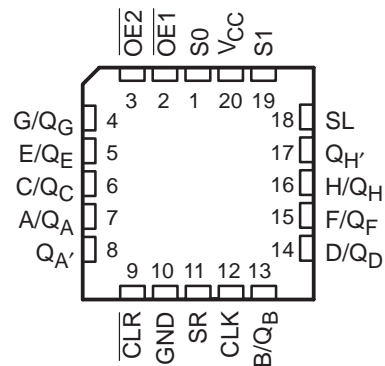

SN54ALS299, SN74ALS299 8-BIT UNIVERSAL SHIFT/STORAGE REGISTERS WITH 3-STATE OUTPUTS

SDAS220B – DECEMBER 1982 – REVISED DECEMBER 1994

FUNCTION TABLE

MODE	INPUTS								I/O PORTS								OUTPUTS	
	CLR	S1	S0	$\overline{OE1}^\dagger$	$\overline{OE2}^\dagger$	CLK	SL	SR	A/Q _A	B/Q _B	C/Q _C	D/Q _D	E/Q _E	F/Q _F	G/Q _G	H/Q _H	Q _A '	Q _H '
Clear	L	X	L	L	L	X	X	X	L	L	L	L	L	L	L	L	L	L
	L	L	X	L	L	X	X	X	L	L	L	L	L	L	L	L	L	L
	L	H	H	X	X	X	X	X	X	X	X	X	X	X	X	X	L	L
Hold	H	L	L	L	L	X	X	X	Q _{A0}	Q _{B0}	Q _{C0}	Q _{D0}	Q _{E0}	Q _{F0}	Q _{G0}	Q _{H0}	Q _{A0}	Q _{H0}
	H	X	X	L	L	L	X	X	Q _{A0}	Q _{B0}	Q _{C0}	Q _{D0}	Q _{E0}	Q _{F0}	Q _{G0}	Q _{H0}	Q _{A0}	Q _{H0}
Shift Right	H	L	H	L	L	↑	X	H	H	Q _{An}	Q _{Bn}	Q _{Cn}	Q _{Dn}	Q _{En}	Q _{Fn}	Q _{Gn}	H	Q _{Gn}
	H	L	H	L	L	↑	X	L	L	Q _{An}	Q _{Bn}	Q _{Cn}	Q _{Dn}	Q _{En}	Q _{Fn}	Q _{Gn}	L	Q _{Gn}
Shift Left	H	H	L	L	L	↑	H	X	Q _{Bn}	Q _{Cn}	Q _{Dn}	Q _{En}	Q _{Fn}	Q _{Gn}	Q _{Hn}	H	Q _{Bn}	H
	H	H	L	L	L	↑	L	X	Q _{Bn}	Q _{Cn}	Q _{Dn}	Q _{En}	Q _{Fn}	Q _{Gn}	Q _{Hn}	L	Q _{Bn}	L
Load	H	H	H	X	X	↑	X	X	a	b	c	d	e	f	g	h	a	h

NOTE: a . . . h = the level of the steady-state input at inputs A through H, respectively. This data is loaded into the flip-flops while the flip-flop outputs are isolated from the I/O terminals.

† When one or both output-enable inputs are high, the eight I/O terminals are disabled to the high-impedance state; however, sequential operation or clearing of the register is not affected.

logic symbol†

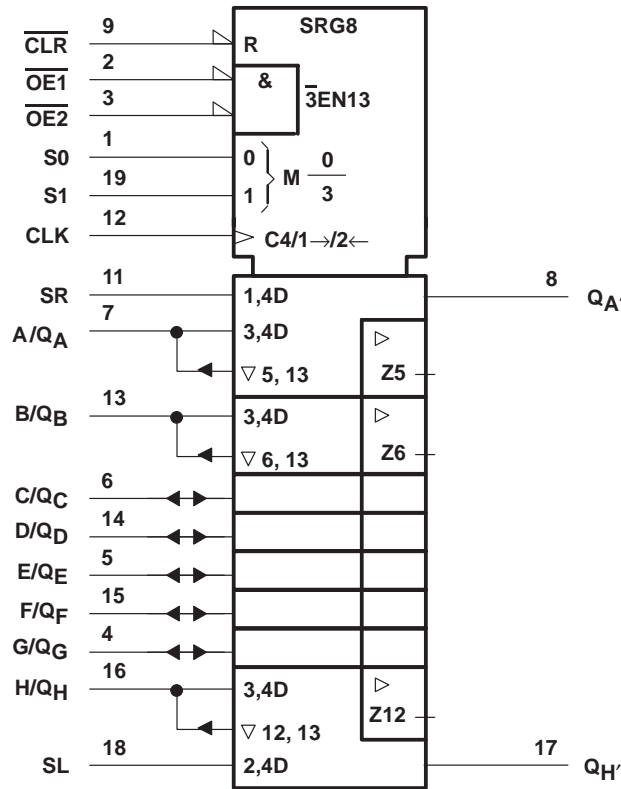

† This symbol is in accordance with ANSI/IEEE Std 91-1984 and IEC Publication 617-12.

SN54ALS299, SN74ALS299 8-BIT UNIVERSAL SHIFT/STORAGE REGISTERS WITH 3-STATE OUTPUTS

SDAS220B – DECEMBER 1982 – REVISED DECEMBER 1994

logic diagram (positive logic)

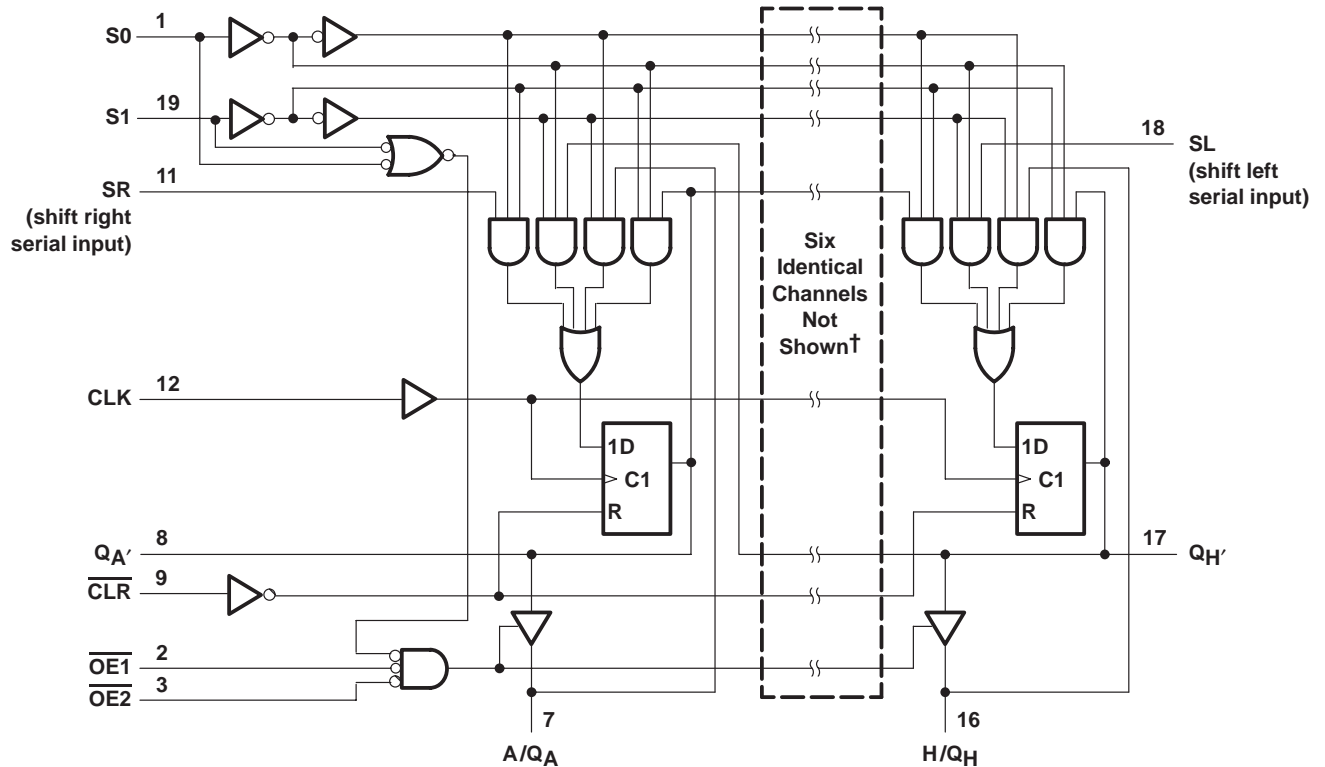

† I/O ports not shown: B/Q_B (13), C/Q_C (6), D/Q_D (14), E/Q_E (5), F/Q_F (15), and G/Q_G (4).

absolute maximum ratings over operating free-air temperature range (unless otherwise noted)‡

Supply voltage, V_{CC}	7 V
Input voltage, V_I : All inputs	7 V
I/O ports	5.5 V
Operating free-air temperature range, T_A : SN54ALS299	-55°C to 125°C
SN74ALS299	0°C to 70°C
Storage temperature range	-65°C to 150°C

‡ Stresses beyond those listed under "absolute maximum ratings" may cause permanent damage to the device. These are stress ratings only, and functional operation of the device at these or any other conditions beyond those indicated under "recommended operating conditions" is not implied. Exposure to absolute-maximum-rated conditions for extended periods may affect device reliability.

SN54ALS299, SN74ALS299

8-BIT UNIVERSAL SHIFT/STORAGE REGISTERS

WITH 3-STATE OUTPUTS

SDAS220B – DECEMBER 1982 – REVISED DECEMBER 1994

recommended operating conditions

		SN54ALS299			SN74ALS299			UNIT		
		MIN	NOM	MAX	MIN	NOM	MAX			
V_{CC}	Supply voltage	4.5	5	5.5	4.5	5	5.5	V		
V_{IH}	High-level input voltage	2			2			V		
V_{IL}	Low-level input voltage			0.7			0.8	V		
I_{OH}	High-level output current	Q_A' or Q_H'		-0.4			-0.4	mA		
		$Q_A - Q_H$			-1				-2.6	
I_{OL}	Low-level output current	Q_A' or Q_H'		4		8		mA		
		$Q_A - Q_H$		12		24				
T_A	Operating free-air temperature	-55			125			0	70	°C

electrical characteristics over recommended operating free-air temperature range (unless otherwise noted)

PARAMETER		TEST CONDITIONS		SN54ALS299			SN74ALS299			UNIT
				MIN	TYP†	MAX	MIN	TYP†	MAX	
V_{IK}		$V_{CC} = 4.5\text{ V}$, $I_I = -18\text{ mA}$		-1.5			-1.5			V
V_{OH}	All outputs	$V_{CC} = 4.5\text{ V to } 5.5\text{ V}$, $I_{OH} = -0.4\text{ mA}$		$V_{CC} - 2$			$V_{CC} - 2$			V
	$Q_A - Q_H$	$V_{CC} = 4.5\text{ V}$		2.4 3.3			2.4 3.2			
V_{OL}	Q_A' or Q_H'	$V_{CC} = 4.5\text{ V}$		0.25 0.4			0.25 0.4			V
				I _{OL} = 4 mA			I _{OL} = 8 mA			
	$Q_A - Q_H$	$V_{CC} = 4.5\text{ V}$		0.25 0.4			0.25 0.4			
				I _{OL} = 12 mA			I _{OL} = 24 mA			
I_I	A - H	$V_{CC} = 5.5\text{ V}$		0.1			0.1			mA
	Any others			0.1			0.1			
$I_{IH}‡$		$V_{CC} = 5.5\text{ V}$, $V_I = 2.7\text{ V}$		20			20			μA
$I_{IL}‡$	S0, S1, SR, SL	$V_{CC} = 5.5\text{ V}$, $V_I = 0.4\text{ V}$		-0.2			-0.2			mA
	Any others			-0.1			-0.1			
$I_{OS}§$	Q_A' or Q_H'	$V_{CC} = 5.5\text{ V}$, $V_O = 2.25\text{ V}$		-15 -70			-15 -70			mA
	$Q_A - Q_H$			-20 -112			-30 -112			
I_{CC}		$V_{CC} = 5.5\text{ V}$		15 28			15 28			mA
				Outputs high			Outputs low			
				22 38			22 38			
				23 40			23 40			

† All typical values are at $V_{CC} = 5\text{ V}$, $T_A = 25^\circ\text{C}$.

‡ For I/O ports ($Q_A - Q_H$), the parameters I_{IH} and I_{IL} include the off-state output current.

§ The output conditions have been chosen to produce a current that closely approximates one half of the true short-circuit output current, I_{OS} .

SN54ALS299, SN74ALS299 8-BIT UNIVERSAL SHIFT/STORAGE REGISTERS WITH 3-STATE OUTPUTS

SDAS220B – DECEMBER 1982 – REVISED DECEMBER 1994

timing requirements over recommended ranges of supply voltage and operating free-air temperature (unless otherwise noted)

		SN54ALS299		SN74ALS299		UNIT	
		MIN	MAX	MIN	MAX		
f_{clock}	Clock frequency (at 50% duty cycle)	0	17	0	30	MHz	
t_w	Pulse duration	CLK high or low		16.5		ns	
		CLR low		10			
t_{su}	Setup time before CLK \uparrow	S0 or S1		20		ns	
		Serial or parallel data	High		16		
			Low		6		
	Inactive-state setup time before CLK \uparrow \dagger	CLR		15			
t_h	Hold time after CLK \uparrow	S0 or S1		0		ns	
		Serial or parallel data		0			

\dagger Inactive-state setup time is also referred to as recovery time.

switching characteristics (see Figure 1)

PARAMETER	FROM (INPUT)	TO (OUTPUT)	$V_{\text{CC}} = 4.5 \text{ V to } 5.5 \text{ V},$ $C_L = 50 \text{ pF},$ $R_1 = 500 \Omega,$ $R_2 = 500 \Omega,$ $T_A = \text{MIN to MAX}\ddagger$				UNIT
			SN54ALS299		SN74ALS299		
			MIN	MAX	MIN	MAX	
f_{max}			17		30	MHz	
t_{PLH}	CLK	$Q_A - Q_H$	2	19	4	13	ns
t_{PHL}			4	25	7	19	
t_{PLH}	CLK	$Q_{A'} \text{ or } Q_{H'}$	2	21	5	15	ns
t_{PHL}			4	25	8	18	
t_{PHL}	CLR	$Q_A - Q_H$	6	29	6	22	ns
		$Q_{A'} \text{ or } Q_{H'}$	6	29	6	22	
t_{PZH}	$\overline{OE1}, \overline{OE2}$	$Q_A - Q_H$	5	22	6	16	ns
t_{PZL}			6	27	8	22	
t_{PZH}	S0, S1	$Q_A - Q_H$	5	27	7	17	ns
t_{PZL}			6	26	8	22	
t_{PHZ}	$\overline{OE1}, \overline{OE2}$	$Q_A - Q_H$	1	15	1	8	ns
t_{PLZ}			4	38	5	15	
t_{PHZ}	S0, S1	$Q_A - Q_H$	1	16	1	12	ns
t_{PLZ}			4	34	8	25	

\ddagger For conditions shown as MIN or MAX, use the appropriate value specified under recommended operating conditions.

SN54ALS299, SN74ALS299 8-BIT UNIVERSAL SHIFT/STORAGE REGISTERS WITH 3-STATE OUTPUTS

SDAS220B – DECEMBER 1982 – REVISED DECEMBER 1994









PARAMETER MEASUREMENT INFORMATION SERIES 54ALS/74ALS AND 54AS/74AS DEVICES

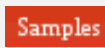

- NOTES: A. C_L includes probe and jig capacitance.
 B. Waveform 1 is for an output with internal conditions such that the output is low except when disabled by the output control. Waveform 2 is for an output with internal conditions such that the output is high except when disabled by the output control.
 C. When measuring propagation delay items of 3-state outputs, switch S1 is open.
 D. All input pulses have the following characteristics: $PRR \leq 1$ MHz, $t_r = t_f = 2$ ns, duty cycle = 50%.
 E. The outputs are measured one at a time with one transition per measurement.

Figure 1. Load Circuits and Voltage Waveforms

PACKAGING INFORMATION

Orderable Device	Status (1)	Package Type	Package Drawing	Pins	Package Qty	Eco Plan (2)	Lead/Ball Finish (6)	MSL Peak Temp (3)	Op Temp (°C)	Device Marking (4/5)	Samples
83021012A	ACTIVE	LCCC	FK	20	1	TBD	POST-PLATE	N / A for Pkg Type	-55 to 125	83021012A SNJ54ALS 299FK	
8302101RA	ACTIVE	CDIP	J	20	1	TBD	A42	N / A for Pkg Type	-55 to 125	8302101RA SNJ54ALS299J	
8302101SA	ACTIVE	CFP	W	20	1	TBD	A42	N / A for Pkg Type	-55 to 125	8302101SA SNJ54ALS299W	
SN74ALS299DW	ACTIVE	SOIC	DW	20	25	Green (RoHS & no Sb/Br)	CU NIPDAU	Level-1-260C-UNLIM	0 to 70	ALS299	
SN74ALS299N	ACTIVE	PDIP	N	20	20	Pb-Free (RoHS)	CU NIPDAU	N / A for Pkg Type	0 to 70	SN74ALS299N	
SNJ54ALS299FK	ACTIVE	LCCC	FK	20	1	TBD	POST-PLATE	N / A for Pkg Type	-55 to 125	83021012A SNJ54ALS 299FK	
SNJ54ALS299J	ACTIVE	CDIP	J	20	1	TBD	A42	N / A for Pkg Type	-55 to 125	8302101RA SNJ54ALS299J	
SNJ54ALS299W	ACTIVE	CFP	W	20	1	TBD	A42	N / A for Pkg Type	-55 to 125	8302101SA SNJ54ALS299W	

(1) The marketing status values are defined as follows:

ACTIVE: Product device recommended for new designs.

LIFEBUY: TI has announced that the device will be discontinued, and a lifetime-buy period is in effect.

NRND: Not recommended for new designs. Device is in production to support existing customers, but TI does not recommend using this part in a new design.

PREVIEW: Device has been announced but is not in production. Samples may or may not be available.

OBSOLETE: TI has discontinued the production of the device.

(2) Eco Plan - The planned eco-friendly classification: Pb-Free (RoHS), Pb-Free (RoHS Exempt), or Green (RoHS & no Sb/Br) - please check <http://www.ti.com/productcontent> for the latest availability information and additional product content details.

TBD: The Pb-Free/Green conversion plan has not been defined.

Pb-Free (RoHS): TI's terms "Lead-Free" or "Pb-Free" mean semiconductor products that are compatible with the current RoHS requirements for all 6 substances, including the requirement that lead not exceed 0.1% by weight in homogeneous materials. Where designed to be soldered at high temperatures, TI Pb-Free products are suitable for use in specified lead-free processes.

Pb-Free (RoHS Exempt): This component has a RoHS exemption for either 1) lead-based flip-chip solder bumps used between the die and package, or 2) lead-based die adhesive used between the die and leadframe. The component is otherwise considered Pb-Free (RoHS compatible) as defined above.

Green (RoHS & no Sb/Br): TI defines "Green" to mean Pb-Free (RoHS compatible), and free of Bromine (Br) and Antimony (Sb) based flame retardants (Br or Sb do not exceed 0.1% by weight in homogeneous material)

(3) MSL, Peak Temp. - The Moisture Sensitivity Level rating according to the JEDEC industry standard classifications, and peak solder temperature.

(4) There may be additional marking, which relates to the logo, the lot trace code information, or the environmental category on the device.

(5) Multiple Device Markings will be inside parentheses. Only one Device Marking contained in parentheses and separated by a "~" will appear on a device. If a line is indented then it is a continuation of the previous line and the two combined represent the entire Device Marking for that device.

(6) Lead/Ball Finish - Orderable Devices may have multiple material finish options. Finish options are separated by a vertical ruled line. Lead/Ball Finish values may wrap to two lines if the finish value exceeds the maximum column width.

Important Information and Disclaimer:The information provided on this page represents TI's knowledge and belief as of the date that it is provided. TI bases its knowledge and belief on information provided by third parties, and makes no representation or warranty as to the accuracy of such information. Efforts are underway to better integrate information from third parties. TI has taken and continues to take reasonable steps to provide representative and accurate information but may not have conducted destructive testing or chemical analysis on incoming materials and chemicals. TI and TI suppliers consider certain information to be proprietary, and thus CAS numbers and other limited information may not be available for release.

In no event shall TI's liability arising out of such information exceed the total purchase price of the TI part(s) at issue in this document sold by TI to Customer on an annual basis.

OTHER QUALIFIED VERSIONS OF SN54ALS299, SN74ALS299 :

- Catalog: [SN74ALS299](#)
- Military: [SN54ALS299](#)

NOTE: Qualified Version Definitions:

- Catalog - TI's standard catalog product
- Military - QML certified for Military and Defense Applications

J (R-GDIP-T**)

14 LEADS SHOWN

CERAMIC DUAL IN-LINE PACKAGE



DIM \ PINS **	14	16	18	20
A	0.300 (7,62) BSC	0.300 (7,62) BSC	0.300 (7,62) BSC	0.300 (7,62) BSC
B MAX	0.785 (19,94)	.840 (21,34)	0.960 (24,38)	1.060 (26,92)
B MIN	—	—	—	—
C MAX	0.300 (7,62)	0.300 (7,62)	0.310 (7,87)	0.300 (7,62)
C MIN	0.245 (6,22)	0.245 (6,22)	0.220 (5,59)	0.245 (6,22)



4040083/F 03/03

- NOTES:
- All linear dimensions are in inches (millimeters).
 - This drawing is subject to change without notice.
 - This package is hermetically sealed with a ceramic lid using glass frit.
 - Index point is provided on cap for terminal identification only on press ceramic glass frit seal only.
 - Falls within MIL STD 1835 GDIP1-T14, GDIP1-T16, GDIP1-T18 and GDIP1-T20.

DW0020A



PACKAGE OUTLINE

SOIC - 2.65 mm max height

SOIC

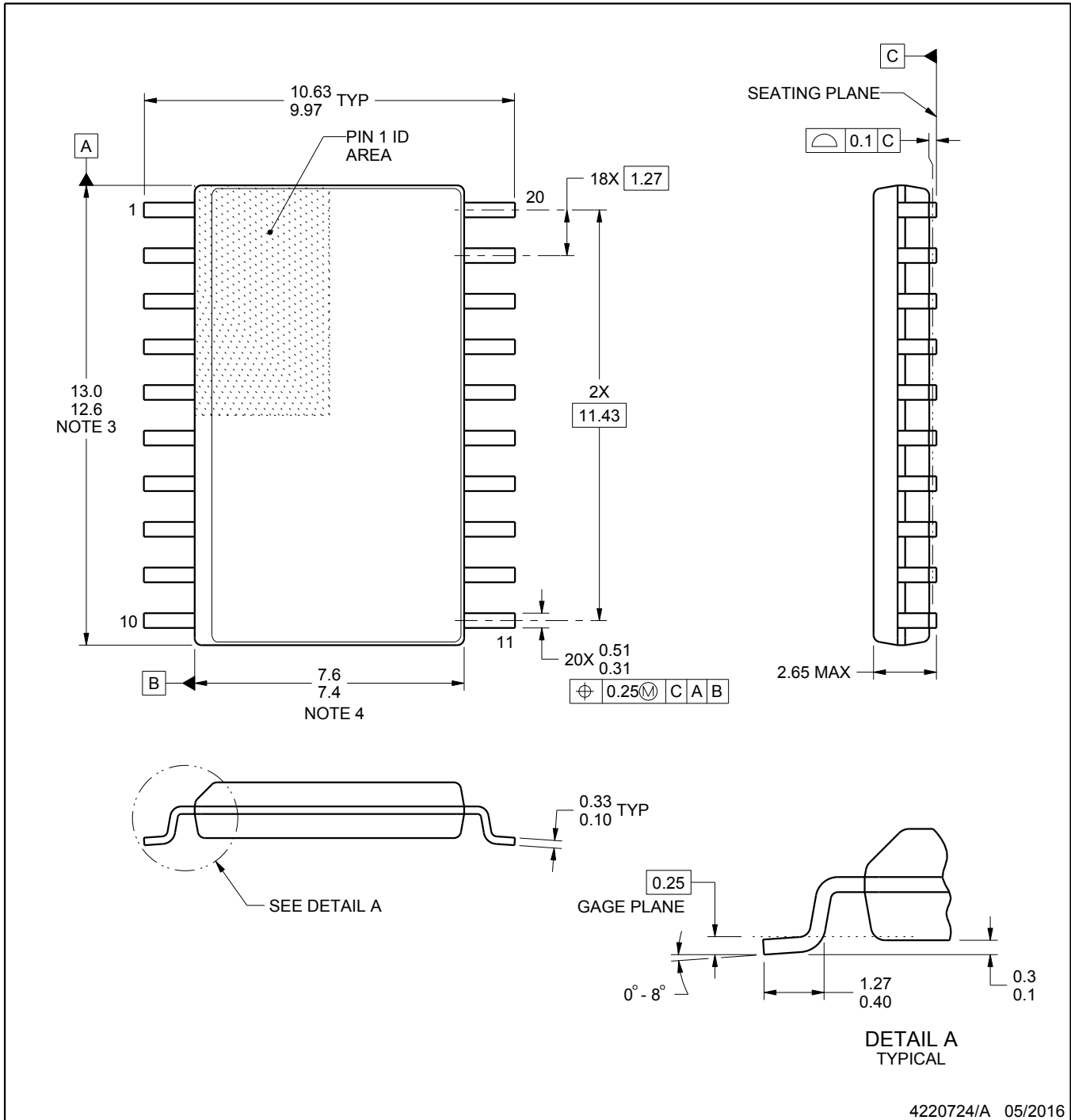

4220724/A 05/2016

NOTES:

1. All linear dimensions are in millimeters. Dimensions in parenthesis are for reference only. Dimensioning and tolerancing per ASME Y14.5M.
2. This drawing is subject to change without notice.
3. This dimension does not include mold flash, protrusions, or gate burrs. Mold flash, protrusions, or gate burrs shall not exceed 0.15 mm per side.
4. This dimension does not include interlead flash. Interlead flash shall not exceed 0.43 mm per side.
5. Reference JEDEC registration MS-013.

EXAMPLE BOARD LAYOUT

DW0020A

SOIC - 2.65 mm max height

SOIC



LAND PATTERN EXAMPLE
SCALE:6X



SOLDER MASK DETAILS

4220724/A 05/2016

NOTES: (continued)

- 6. Publication IPC-7351 may have alternate designs.
- 7. Solder mask tolerances between and around signal pads can vary based on board fabrication site.

EXAMPLE STENCIL DESIGN

DW0020A

SOIC - 2.65 mm max height

SOIC

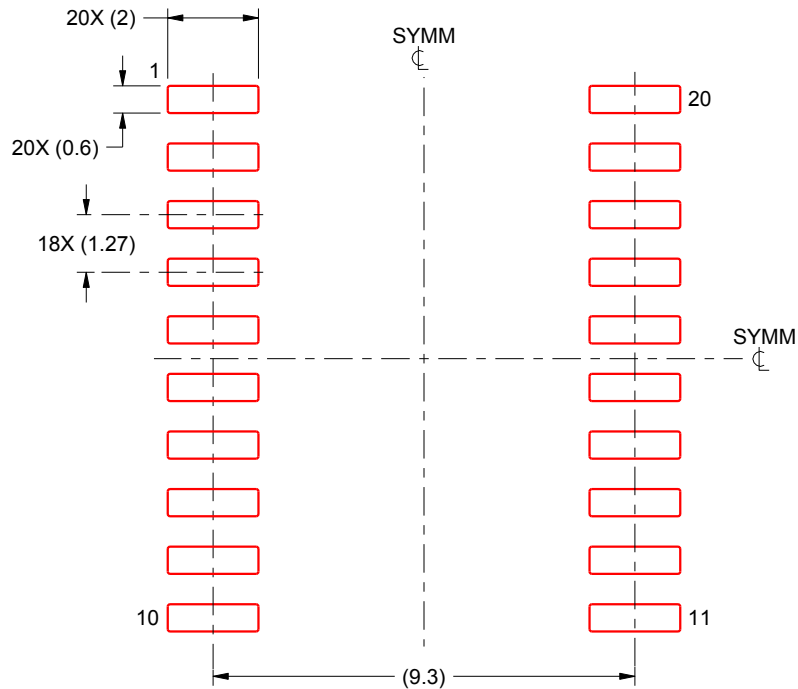

SOLDER PASTE EXAMPLE
BASED ON 0.125 mm THICK STENCIL
SCALE:6X

4220724/A 05/2016

NOTES: (continued)

8. Laser cutting apertures with trapezoidal walls and rounded corners may offer better paste release. IPC-7525 may have alternate design recommendations.
9. Board assembly site may have different recommendations for stencil design.

FK (S-CQCC-N**)

LEADLESS CERAMIC CHIP CARRIER

28 TERMINAL SHOWN



NO. OF TERMINALS **	A		B	
	MIN	MAX	MIN	MAX
20	0.342 (8,69)	0.358 (9,09)	0.307 (7,80)	0.358 (9,09)
28	0.442 (11,23)	0.458 (11,63)	0.406 (10,31)	0.458 (11,63)
44	0.640 (16,26)	0.660 (16,76)	0.495 (12,58)	0.560 (14,22)
52	0.740 (18,78)	0.761 (19,32)	0.495 (12,58)	0.560 (14,22)
68	0.938 (23,83)	0.962 (24,43)	0.850 (21,6)	0.858 (21,8)
84	1.141 (28,99)	1.165 (29,59)	1.047 (26,6)	1.063 (27,0)



4040140/D 01/11

- NOTES:
- All linear dimensions are in inches (millimeters).
 - This drawing is subject to change without notice.
 - This package can be hermetically sealed with a metal lid.
 - Falls within JEDEC MS-004

W (R-GDFP-F20)

CERAMIC DUAL FLATPACK



- NOTES:
- A. All linear dimensions are in inches (millimeters).
 - B. This drawing is subject to change without notice.
 - C. This package can be hermetically sealed with a ceramic lid using glass frit.
 - D. Index point is provided on cap for terminal identification only.
 - E. Falls within Mil-Std 1835 GDFP2-F20

IMPORTANT NOTICE AND DISCLAIMER

TI PROVIDES TECHNICAL AND RELIABILITY DATA (INCLUDING DATASHEETS), DESIGN RESOURCES (INCLUDING REFERENCE DESIGNS), APPLICATION OR OTHER DESIGN ADVICE, WEB TOOLS, SAFETY INFORMATION, AND OTHER RESOURCES "AS IS" AND WITH ALL FAULTS, AND DISCLAIMS ALL WARRANTIES, EXPRESS AND IMPLIED, INCLUDING WITHOUT LIMITATION ANY IMPLIED WARRANTIES OF MERCHANTABILITY, FITNESS FOR A PARTICULAR PURPOSE OR NON-INFRINGEMENT OF THIRD PARTY INTELLECTUAL PROPERTY RIGHTS.

These resources are intended for skilled developers designing with TI products. You are solely responsible for (1) selecting the appropriate TI products for your application, (2) designing, validating and testing your application, and (3) ensuring your application meets applicable standards, and any other safety, security, or other requirements. These resources are subject to change without notice. TI grants you permission to use these resources only for development of an application that uses the TI products described in the resource. Other reproduction and display of these resources is prohibited. No license is granted to any other TI intellectual property right or to any third party intellectual property right. TI disclaims responsibility for, and you will fully indemnify TI and its representatives against, any claims, damages, costs, losses, and liabilities arising out of your use of these resources.

TI's products are provided subject to TI's Terms of Sale (www.ti.com/legal/termsofsale.html) or other applicable terms available either on ti.com or provided in conjunction with such TI products. TI's provision of these resources does not expand or otherwise alter TI's applicable warranties or warranty disclaimers for TI products.

Mailing Address: Texas Instruments, Post Office Box 655303, Dallas, Texas 75265
Copyright © 2019, Texas Instruments Incorporated

Looking for pricing, stock, or lifecycle information?

Click below to explore more details on WIN SOURCE:

 [View SN74ALS299DWR on WIN SOURCE](#)

 [Texas Instruments](#) Information

Optimize Your Supply Chain with WIN SOURCE Solutions

-  Global Sourcing Solution
-  Obsolete Management
-  Cost Control Management
-  Shortage Management
-  Alternative Solution
-  Excess Inventory Management