



**THE DATASHEET OF  
PCM1850APJTR**





## 24-BIT, 96-kHz STEREO A/D CONVERTER WITH 6 × 2-CHANNEL MUX AND PGAE

### FEATURES

- Multiplexer and Programmable-Gain Amplifier (PGA)
  - 6×2-Channel Single-Ended Inputs
  - Multiplexed Output
  - Maximum Input Level: 2.4 V rms
  - Input Resistance: 50 k $\Omega$ , Minimum
  - PGA Gain: 11-dB to –11-dB Range, 0.5 dB/Step
- 24-Bit Delta-Sigma Stereo A/D Converter
- Antialiasing Filter Included
- Oversampling Decimation Filter
  - Oversampling Frequency:  $\times 64$
  - Pass-Band Ripple:  $\pm 0.05$  dB
  - Stop-Band Attenuation: –65 dB
  - On-Chip High-Pass Filter: 0.91 Hz (48 kHz)
- High Performance
  - THD+N: 0.0023% (Typically)
  - SNR: 101 dB (Typically)
  - Dynamic Range: 102 dB (Typically)
- PCM Audio Interface
  - Master/Slave Mode Selectable
  - Data Formats: 24-Bit Left-Justified, 24-Bit I<sup>2</sup>S, 16-, 24-Bit Right-Justified
- Mode Control by Serial Interface:
  - With SPI Control (PCM1850A)
  - With I<sup>2</sup>C Control (PCM1851A)
- Sampling Rate: 16–96 kHz
- System Clock: 256 f<sub>s</sub>, 384 f<sub>s</sub>, 512 f<sub>s</sub>, 768 f<sub>s</sub>
- Dual Power Supplies: 5 V for Analog, 3.3 V for Digital
- Package: 32-Pin TQFP

### APPLICATIONS

- DVD/HDD/DVD+HDD Recorder
- AV Amplifier Receiver
- CD Recorder
- MD Recorder
- Multitrack Recorder
- Electric Musical Instrument

### DESCRIPTION

The PCM1850A/1851A is a high-performance, low-cost, single-chip stereo analog-to-digital converter with a single-ended analog front end that consists of a 6-stereo-input multiplexer and wide-range PGA. The PCM1850A/1851A includes a delta-sigma modulator with 64-times oversampling, a digital decimation filter and a low-cut filter that removes the dc component of the input signal. For various applications, the PCM1850A/1851A supports two modes (master and slave) and four data formats through a serial control interface, SPI for the PCM1850A and I<sup>2</sup>C for the PCM1851A. The PCM1850A/1851A is suitable for a wide variety of cost-sensitive DVD/CD/MD recorder and receiver applications where good performance and operation from a 5-V analog supply and 3.3-V digital supply is required. The PCM1850A/1851A is fabricated using a highly advanced CMOS process and is available in a small 32-pin TQFP package.



Please be aware that an important notice concerning availability, standard warranty, and use in critical applications of Texas Instruments semiconductor products and disclaimers thereto appears at the end of this data sheet.

System Two, Audio Precision are trademarks of Audio Precision, Inc.  
All other trademarks are the property of their respective owners.



This integrated circuit can be damaged by ESD. Texas Instruments recommends that all integrated circuits be handled with appropriate precautions. Failure to observe proper handling and installation procedures can cause damage.

ESD damage can range from subtle performance degradation to complete device failure. Precision integrated circuits may be more susceptible to damage because very small parametric changes could cause the device not to meet its published specifications.

## BLOCK DIAGRAM

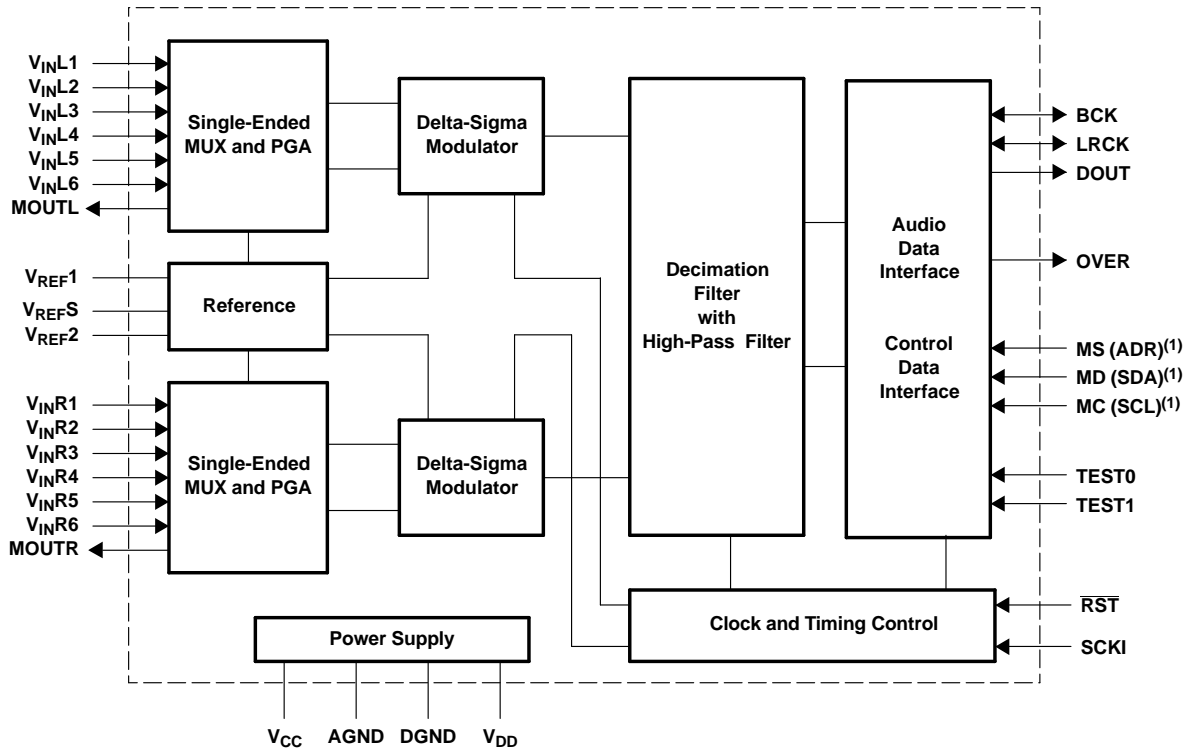

(1) PCM1850A (PCM1851A)

B0004-09

## PIN ASSIGNMENTS

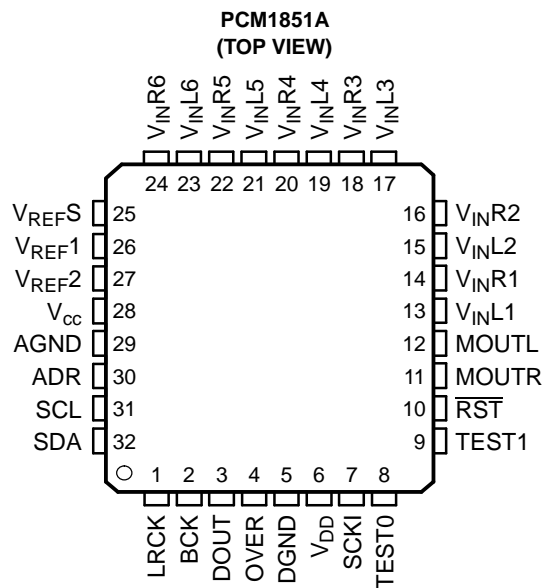
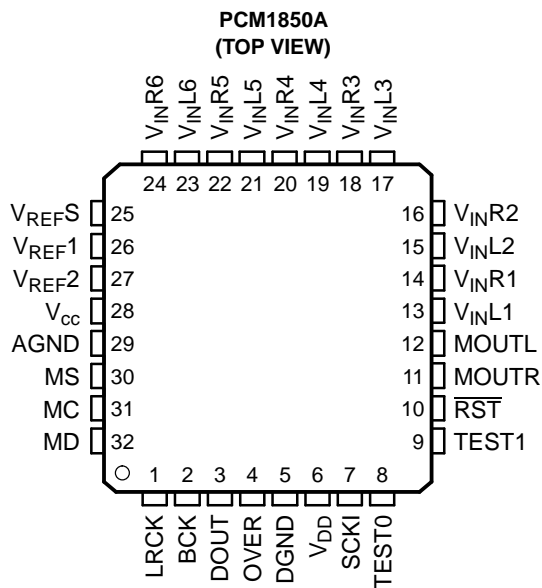

P0040-01

**TERMINAL FUNCTIONS**
**PCM1850A**

TERMINAL		I/O	DESCRIPTION
NAME	NO.		
AGND	29	—	Analog GND
BCK	2	I/O	Bit clock input/output <sup>(1)</sup>
DGND	5	—	Digital GND
DOUT	3	O	Audio data output
LRCK	1	I/O	Sampling clock input/output <sup>(1)</sup>
MC	31	I	Mode-control clock input <sup>(2)</sup>
MD	32	I	Mode-control data input <sup>(2)</sup>
MOU <sub>T</sub> L	12	O	Multiplexer output, L-channel
MOU <sub>T</sub> R	11	O	Multiplexer output, R-channel
MS	30	I	Mode-control select input <sup>(3)</sup>
OVER	4	O	Overflow flag
RST	10	I	Reset, active-LOW <sup>(3)</sup>
SCKI	7	I	System clock input; 256 f <sub>S</sub> , 384 f <sub>S</sub> , 512 f <sub>S</sub> , or 768 f <sub>S</sub> <sup>(2)</sup>
TEST0	8	I	Test 0, must be connected to GND <sup>(3)</sup>
TEST1	9	I	Test 1, must be connected to GND <sup>(3)</sup>
V <sub>CC</sub>	28	—	Analog power supply, 5-V
V <sub>DD</sub>	6	—	Digital power supply, 3.3-V
V <sub>IN</sub> L1	13	I	Analog input 1, L-channel
V <sub>IN</sub> L2	15	I	Analog input 2, L-channel
V <sub>IN</sub> L3	17	I	Analog input 3, L-channel
V <sub>IN</sub> L4	19	I	Analog input 4, L-channel
V <sub>IN</sub> L5	21	I	Analog input 5, L-channel
V <sub>IN</sub> L6	23	I	Analog input 6, L-channel
V <sub>IN</sub> R1	14	I	Analog input 1, R-channel
V <sub>IN</sub> R2	16	I	Analog input 2, R-channel
V <sub>IN</sub> R3	18	I	Analog input 3, R-channel
V <sub>IN</sub> R4	20	I	Analog input 4, R-channel
V <sub>IN</sub> R5	22	I	Analog input 5, R-channel
V <sub>IN</sub> R6	24	I	Analog input 6, R-channel
V <sub>REF</sub> S	25	—	Reference S decoupling capacitor (= 0.5 V <sub>CC</sub> )
V <sub>REF</sub> 1	26	—	Reference 1 decoupling capacitor (= 0.5 V <sub>CC</sub> )
V <sub>REF</sub> 2	27	—	Reference 2 decoupling capacitor (= V <sub>CC</sub> )

(1) Schmitt-trigger input with internal pulldown resistor (50 kΩ, typically)

(2) Schmitt-trigger input, 5-V tolerant

(3) Schmitt-trigger input with internal pulldown resistor (50 kΩ, typically), 5-V tolerant

PCM1851A

TERMINAL		I/O	DESCRIPTION
NAME	NO.		
ADR	30	I	Mode control address select input <sup>(1)</sup>
AGND	29	—	Analog GND
BCK	2	I/O	Bit clock input/output <sup>(2)</sup>
DGND	5	—	Digital GND
DOUT	3	O	Audio data output
LRCK	1	I/O	Sampling clock input/output <sup>(2)</sup>
MOU <sub>TL</sub>	12	O	Multiplexer output, L-channel
MOU <sub>TR</sub>	11	O	Multiplexer output, R-channel
OVER	4	O	Overflow flag
$\overline{\text{RST}}$	10	I	Reset, active-LOW <sup>(1)</sup>
SCKI	7	I	System clock input; 256 f <sub>S</sub> , 384 f <sub>S</sub> , 512 f <sub>S</sub> , or 768 f <sub>S</sub> <sup>(3)</sup>
SCL	31	I	Mode-control clock input <sup>(3)</sup>
SDA	32	I/O	Mode-control data input/output <sup>(4)</sup>
TEST0	8	I	Test 0, must be connected to GND <sup>(1)</sup>
TEST1	9	I	Test 1, must be connected to GND <sup>(1)</sup>
V <sub>CC</sub>	28	—	Analog power supply, 5-V
V <sub>DD</sub>	6	—	Digital power supply, 3.3-V
V <sub>INL1</sub>	13	I	Analog input 1, L-channel
V <sub>INL2</sub>	15	I	Analog input 2, L-channel
V <sub>INL3</sub>	17	I	Analog input 3, L-channel
V <sub>INL4</sub>	19	I	Analog input 4, L-channel
V <sub>INL5</sub>	21	I	Analog input 5, L-channel
V <sub>INL6</sub>	23	I	Analog input 6, L-channel
V <sub>INR1</sub>	14	I	Analog input 1, R-channel
V <sub>INR2</sub>	16	I	Analog input 2, R-channel
V <sub>INR3</sub>	18	I	Analog input 3, R-channel
V <sub>INR4</sub>	20	I	Analog input 4, R-channel
V <sub>INR5</sub>	22	I	Analog input 5, R-channel
V <sub>INR6</sub>	24	I	Analog input 6, R-channel
V <sub>REFS</sub>	25	—	Reference S decoupling capacitor (= 0.5 V <sub>CC</sub> )
V <sub>REF1</sub>	26	—	Reference 1 decoupling capacitor (= 0.5 V <sub>CC</sub> )
V <sub>REF2</sub>	27	—	Reference 2 decoupling capacitor (= V <sub>CC</sub> )

- (1) Schmitt-trigger input with internal pulldown resistor (50 k $\Omega$ , typically), 5-V tolerant
- (2) Schmitt-trigger input with internal pulldown resistor (50 k $\Omega$ , typically)
- (3) Schmitt-trigger input, 5-V tolerant
- (4) Schmitt-trigger input/open-drain LOW output, 5-V tolerant

## ABSOLUTE MAXIMUM RATINGS<sup>(1)</sup>

over operating free-air temperature range (unless otherwise noted)

		VALUE	UNIT
$V_{CC}$	Supply voltage	-0.3 to 6.5	V
$V_{DD}$		-0.3 to 4	V
Ground voltage differences: AGND, DGND		±0.1	V
Digital input voltage: LRCK, BCK, DOUT, OVER		-0.3 to ( $V_{DD} + 0.3$ ) < 4	V
Digital input voltage: $\overline{RST}$ , SCKI, MS (ADR) <sup>(2)</sup> , MC (SCL) <sup>(2)</sup> , MD (SDA) <sup>(2)</sup> , TEST0, TEST1		-0.3 to 6.5	V
Analog input voltage: $V_{INL1-6}$ , $V_{INR1-6}$		-3 to ( $V_{CC} + 3$ ) < 9	V
Analog input voltage: MOUTL, MOUTR, $V_{REF1}$ , $V_{REF2}$ , $V_{REFS}$		-0.3 to ( $V_{CC} + 0.3$ ) < 6.5	V
Input current (any pins except supplies)		±10	mA
Ambient temperature under bias		-40 to 125	°C
Storage temperature		-55 to 150	°C
Junction temperature		150	°C
Lead temperature (soldering)		260°C, 5 s	
Package temperature (IR reflow, peak)		260	°C

- (1) Stresses beyond those listed under *absolute maximum ratings* may cause permanent damage to the device. These are stress ratings only, and functional operation of the device at these or any other conditions beyond those indicated under *recommended operating conditions* is not implied. Exposure to absolute-maximum-rated conditions for extended periods may affect device reliability.
- (2) PCM1850A (PCM1851A)

## RECOMMENDED OPERATING CONDITIONS

over operating free-air temperature range (unless otherwise noted)

		MIN	NOM	MAX	UNIT	
$V_{CC}$	Analog supply voltage	4.5	5	5.5	V	
$V_{DD}$	Digital supply voltage	2.7	3.3	3.6	V	
	Analog input voltage, full scale (0 dB)	$V_{CC} = 5\text{ V}$ , PGA gain = 5.5 dB			Vrms	
	Digital input logic family	TTL				
	Digital input clock frequency	System clock		4.096	49.152	MHz
		Sampling clock		16	96	kHz
	Digital output load capacitance				20	pF
$T_A$	Operating free-air temperature	40			85	°C

## ELECTRICAL CHARACTERISTICS

All specifications at  $T_A = 25^\circ\text{C}$ ,  $V_{CC} = 5\text{ V}$ ,  $V_{DD} = 3.3\text{ V}$ , master mode,  $f_S = 48\text{ kHz}$ , system clock =  $256 f_S$ , 24-bit data (unless otherwise noted)

PARAMETER	TEST CONDITIONS	PCM1850APJT, PCM1851APJT			UNIT	
		MIN	TYP	MAX		
<b>DIGITAL INPUT/OUTPUT — DATA FORMAT</b>						
Audio data interface format		Left-justified, I <sup>2</sup> S, right-justified				
Audio data bit length		16, 24			bits	
Audio data format		MSB-first, 2s complement				
$f_S$	Sampling frequency	16	48	96	kHz	
	System clock frequency	256 $f_S$	4.096	12.288	24.576	MHz
		384 $f_S$	6.144	18.432	36.864	
		512 $f_S$	8.192	24.576	49.152	
		768 $f_S$	12.288	36.864	—	

## ELECTRICAL CHARACTERISTICS (continued)

All specifications at  $T_A = 25^\circ\text{C}$ ,  $V_{CC} = 5\text{ V}$ ,  $V_{DD} = 3.3\text{ V}$ , master mode,  $f_s = 48\text{ kHz}$ , system clock =  $256 f_s$ , 24-bit data (unless otherwise noted)

PARAMETER	TEST CONDITIONS	PCM1850APJT, PCM1851APJT			UNIT
		MIN	TYP	MAX	
<b>INPUT LOGIC</b>					
$V_{IH}^{(1)}$	Input logic level		2	$V_{DD}$	VDC
$V_{IL}^{(1)}$			0	0.8	
$V_{IH}^{(2)(3)}$			2	5.5	
$V_{IL}^{(2)(3)}$			0	0.8	
$I_{IH}^{(2)}$	Input logic current	$V_{IN} = V_{DD}$		$\pm 10$	$\mu\text{A}$
$I_{IL}^{(2)}$		$V_{IN} = 0$		$\pm 10$	
$I_{IH}^{(1)(3)}$		$V_{IN} = V_{DD}$	65	100	
$I_{IL}^{(1)(3)}$		$V_{IN} = 0$		$\pm 10$	
<b>OUTPUT LOGIC</b>					
$V_{OH}^{(4)}$	Output logic level	$I_{OUT} = -4\text{ mA}$	2.8		VDC
$V_{OL}^{(4)(5)}$		$I_{OUT} = 4\text{ mA}$		0.5	
<b>AFE MULTIPLEXER</b>					
Input channels			6		
Input level for full scale			2	2.4	Vrms
Center voltage ( $V_{REF1}$ )	Selected channel		$0.5 V_{CC}$		V
Center voltage ( $V_{REFS}$ )	Unselected channel		$0.5 V_{CC}$		V
Input impedance	Selected channel		50	169	k $\Omega$
	Unselected channel		50	57	
<b>AFE PGA</b>					
Gain range		-11	0	11	dB
Gain step			0.5		dB
Monotonicity			Specified		
Antialiasing filter frequency response	-3 dB, PGA gain = -5.5 dB		300		kHz
<b>MONITOR OUTPUT</b>					
Output level for full scale	AC-coupled, >10 k $\Omega$		$0.6 V_{CC}$		Vp-p
Output load	AC-coupled		10		k $\Omega$
THD+N <sup>(6)(7)</sup>	AC-coupled, 10 k $\Omega$ , 3 Vp-p output		0.0016%		
S/N	Signal-to-noise ratio <sup>(6)(7)</sup>	AC-coupled, 10 k $\Omega$		104	dB
Gain error <sup>(6)(7)</sup>		AC-coupled, 10 k $\Omega$		-3	% of FSR
Center voltage			$0.5 V_{CC}$		V
<b>ADC</b>					
Resolution			24		bits
Full-scale input voltage			$0.6 V_{CC}$		Vp-p

(1) Pins 1, 2: LRCK, BCK (In slave mode, Schmitt-trigger input, with 50-k $\Omega$  typical pulldown resistor)

(2) Pins 7, 31, 32: SCKI, MC/SCL (PCM1850A/1851A), MD/SDA (PCM1850A/1851A) (Schmitt-trigger input, 5-V tolerant)

(3) Pins 8–10, 30: TEST0, TEST1, RST, MS/ADR (PCM1850A/1851A) (Schmitt-trigger input, with 50-k $\Omega$  typical pulldown resistor, 5-V tolerant)

(4) Pins 1–4: LRCK, BCK (in master mode), DOUT, OVER

(5) Pin 32: SDA (PCM1851A) (open-drain LOW output)

(6) Analog performance specifications are tested with the System Two™ audio measurement system by Audio Precision™, using a 400-Hz HPF and 20-kHz LPF in the RMS mode at  $f_{IN} = 1\text{ kHz}$ .

(7) Reference level (0 dB) is specified as 2-V rms input on  $V_{INL}[1:6]$  and  $V_{INR}[1:6]$  pins with PGA gain of -5.5 dB.

## ELECTRICAL CHARACTERISTICS (continued)

All specifications at  $T_A = 25^\circ\text{C}$ ,  $V_{CC} = 5\text{ V}$ ,  $V_{DD} = 3.3\text{ V}$ , master mode,  $f_S = 48\text{ kHz}$ , system clock =  $256 f_S$ , 24-bit data (unless otherwise noted)

PARAMETER	TEST CONDITIONS	PCM1850APJT, PCM1851APJT			UNIT
		MIN	TYP	MAX	
<b>ACCURACY</b>					
Gain mismatch, channel-to-channel			$\pm 1$	$\pm 3$	% of FSR
Gain error			$\pm 2$	$\pm 5$	% of FSR
Bipolar zero error	High-pass filter bypass		$\pm 2$		% of FSR
<b>DYNAMIC PERFORMANCE</b> <sup>(1)</sup> <sup>(2)</sup>					
THD+N Total harmonic distortion + noise <sup>(3)</sup>	$f_S = 48\text{ kHz}$ , $V_{IN} = -0.5\text{ dB}$ (1.89 Vrms)		0.0023%	0.004%	
	$f_S = 96\text{ kHz}$ <sup>(4)</sup> , $V_{IN} = -0.5\text{ dB}$ (1.89 Vrms)		0.0027%		
	$f_S = 48\text{ kHz}$ , $V_{IN} = -60\text{ dB}$ (2 mVrms)		1%		
	$f_S = 96\text{ kHz}$ <sup>(4)</sup> , $V_{IN} = -60\text{ dB}$ (2 mVrms)		1%		
Dynamic range <sup>(3)</sup>	$f_S = 48\text{ kHz}$ , A-weighted		96	102	dB
	$f_S = 96\text{ kHz}$ <sup>(4)</sup> , A-weighted			102	
S/N Signal-to-noise ratio <sup>(3)</sup>	$f_S = 48\text{ kHz}$ , A-weighted		96	101	dB
	$f_S = 96\text{ kHz}$ <sup>(4)</sup> , A-weighted			102	
Channel separation (between L-ch and R-ch) <sup>(3)</sup>	$f_S = 48\text{ kHz}$		92	98	dB
	$f_S = 96\text{ kHz}$ <sup>(4)</sup>			100	
Channel separation (among channels) <sup>(5)</sup>	$f_S = 48\text{ kHz}$		90	96	dB
	$f_S = 96\text{ kHz}$ <sup>(4)</sup>			96	
<b>DIGITAL FILTER PERFORMANCE</b>					
Pass band				$0.454 f_S$	Hz
Stop band			$0.583 f_S$		Hz
Pass-band ripple				$\pm 0.05$	dB
Stop-band attenuation			-65		dB
Delay time				$17.4/f_S$	s
HPF frequency response	-3 dB			$0.019 f_S$	mHz

- (1) Analog performance specifications are tested with the System Two™ audio measurement system by Audio Precision™, using a 400-Hz HPF and 20-kHz LPF in the RMS mode at  $f_{IN} = 1\text{ kHz}$ .
- (2) Reference level (0 dB) is specified as 2-V rms input on  $V_{INL}[1:6]$  and  $V_{INR}[1:6]$  pins with PGA gain of -5.5 dB.
- (3) Unselected channel inputs are terminated to AGND with 0.33  $\mu\text{F}$ .
- (4)  $f_S = 96\text{ kHz}$ , system clock =  $256 f_S$ .
- (5) 2-V rms input is applied to all unselected channels, and input of selected channel is terminated to AGND with 0.33  $\mu\text{F}$ .

## ELECTRICAL CHARACTERISTICS (continued)

All specifications at  $T_A = 25^\circ\text{C}$ ,  $V_{CC} = 5\text{ V}$ ,  $V_{DD} = 3.3\text{ V}$ , master mode,  $f_S = 48\text{ kHz}$ , system clock =  $256 f_S$ , 24-bit data (unless otherwise noted)

PARAMETER		TEST CONDITIONS	PCM1850APJT, PCM1851APJT			UNIT
			MIN	TYP	MAX	
<b>POWER-SUPPLY REQUIREMENTS</b>						
$V_{CC}$	Voltage range		4.5	5	5.5	VDC
$V_{DD}$			2.7	3.3	3.6	
$I_{CC}$	Supply current <sup>(1)</sup>	Operational		28	35	mA
		Powered down <sup>(2)</sup>		190		$\mu\text{A}$
$I_{DD}$	Supply current <sup>(1)</sup>	$f_S = 48\text{ kHz}$		6	10	mA
		$f_S = 96\text{ kHz}$ <sup>(3)</sup>		12		
		Powered down <sup>(2)</sup> , PCM1850A		80		$\mu\text{A}$
		Powered down <sup>(2)</sup> , PCM1851A		280		
Power dissipation	Power dissipation	Operating, $f_S = 48\text{ kHz}$		160	208	mW
		Operating, $f_S = 96\text{ kHz}$ <sup>(3)</sup>		180		
		Powered down <sup>(2)</sup> , PCM1850A		1.2		
		Powered down <sup>(2)</sup> , PCM1851A		1.9		
<b>TEMPERATURE RANGE</b>						
Operation temperature			-40		85	$^\circ\text{C}$
Thermal resistance ( $\theta_{JA}$ )				80		$^\circ\text{C/W}$

- (1) Minimum load on DOUT (pin 3), BCK (pin 2), LRCK (pin 1)  
(2) Halt SCKI, BCK, LRCK.  
(3)  $f_S = 96\text{ kHz}$ , system clock =  $256 f_S$ .

**TYPICAL PERFORMANCE CURVES OF INTERNAL FILTER**

All specifications at  $T_A = 25^\circ\text{C}$ ,  $V_{CC} = 5\text{ V}$ ,  $V_{DD} = 3.3\text{ V}$ , master mode,  $f_S = 48\text{ kHz}$ , system clock =  $256 f_S$ , 24-bit data (unless otherwise noted).

**DIGITAL FILTER**

**Decimation Filter Frequency Response**

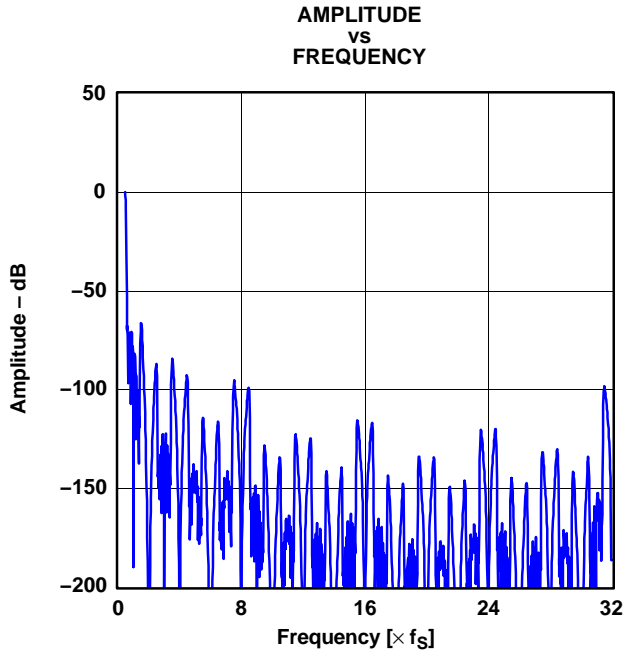

Figure 1. Overall Characteristics

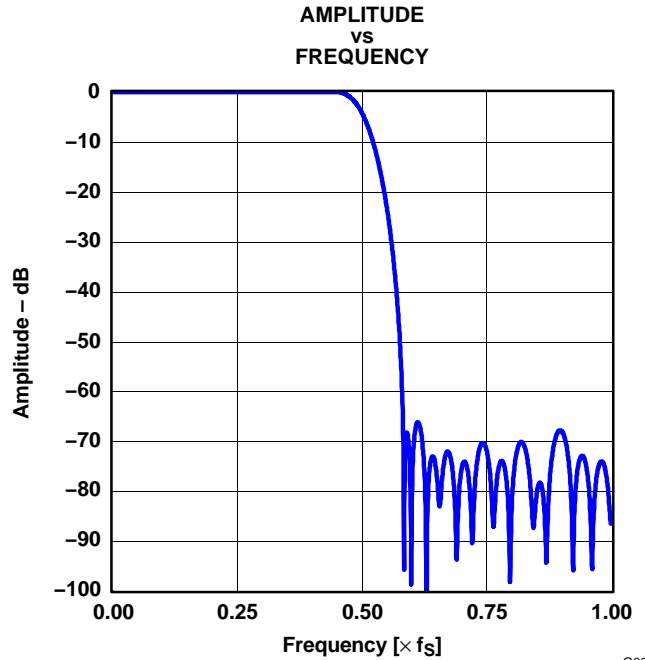

Figure 2. Stop-Band Attenuation Characteristics

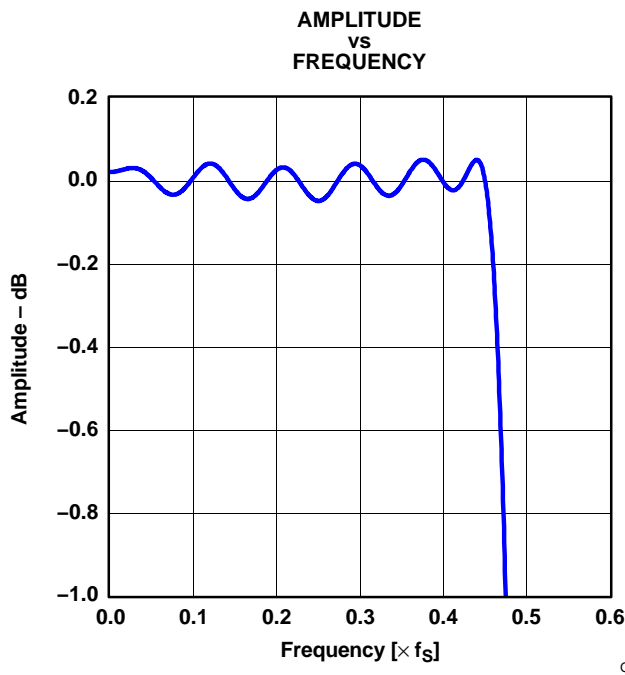

Figure 3. Pass-Band Ripple Characteristics

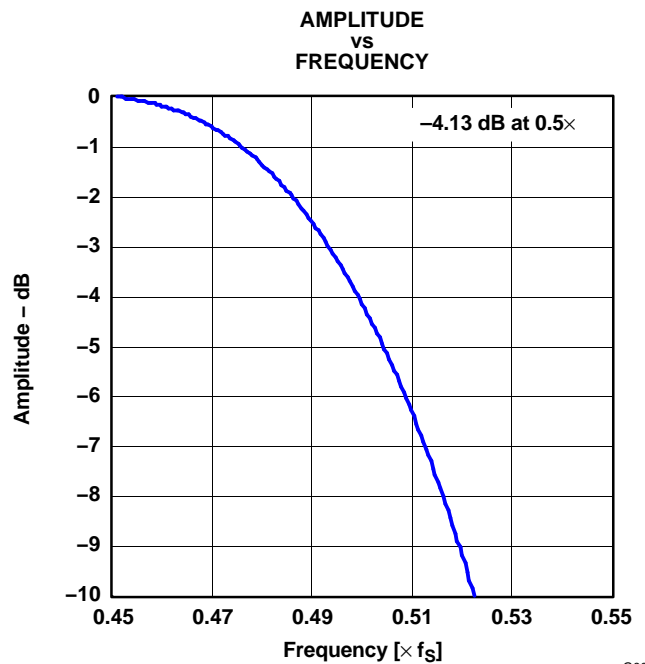

Figure 4. Transition-Band Characteristics

**TYPICAL PERFORMANCE CURVES OF INTERNAL FILTER (continued)**

All specifications at  $T_A = 25^\circ\text{C}$ ,  $V_{CC} = 5\text{ V}$ ,  $V_{DD} = 3.3\text{ V}$ , master mode,  $f_S = 48\text{ kHz}$ , system clock =  $256 f_S$ , 24-bit data (unless otherwise noted).

**High-Pass Filter Frequency Response**

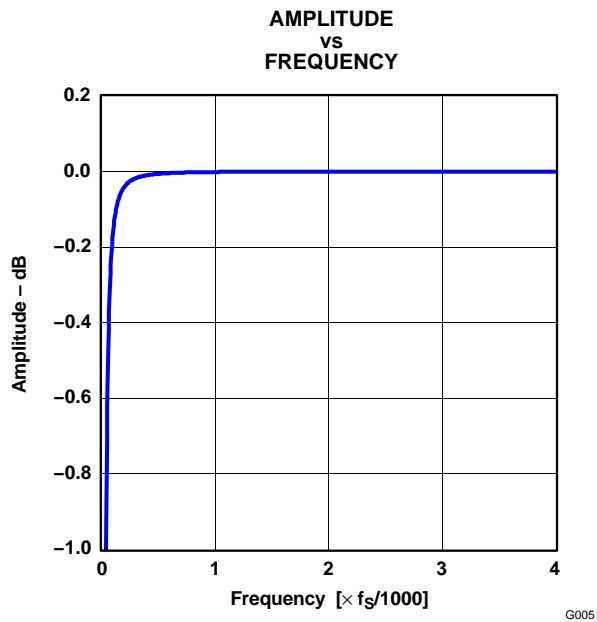

Figure 5. HPF Pass-Band Characteristics

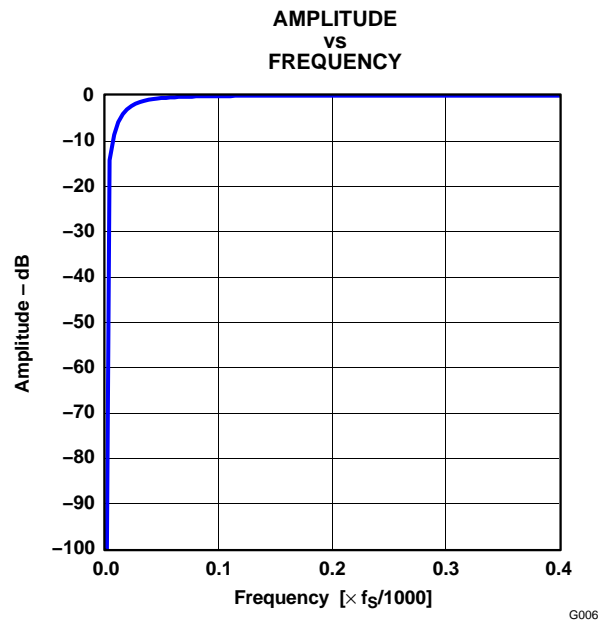

Figure 6. HPF Stop-Band Characteristics

**ANALOG FILTER**

**Antialiasing Filter Frequency Response (at PGA Gain = -5.5 dB)**

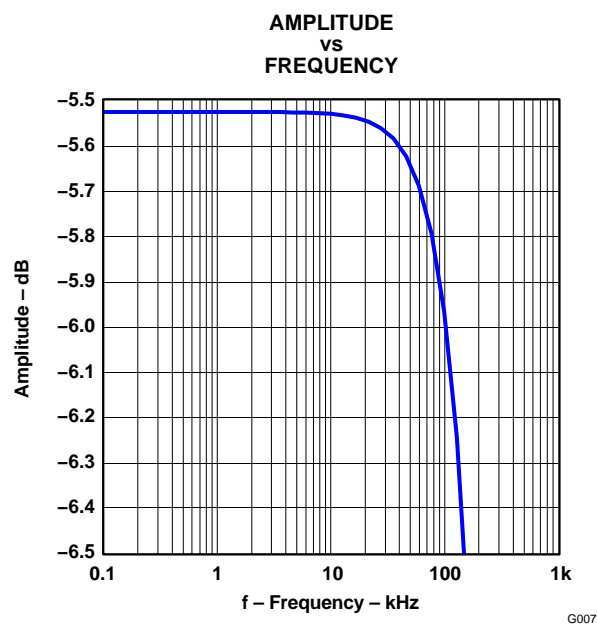

Figure 7. Antialiasing Filter Pass-Band Characteristics

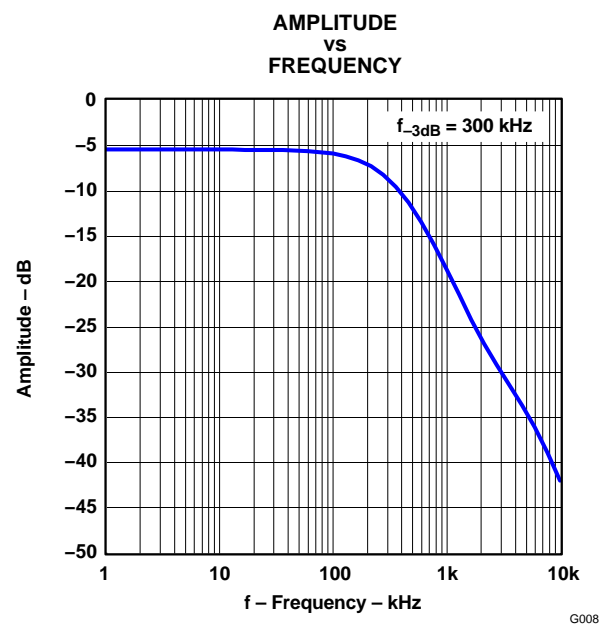

Figure 8. Antialiasing Filter Stop-Band Characteristics

**TYPICAL PERFORMANCE CURVES AT PGA GAIN = -5.5 dB**

All specifications at  $T_A = 25^\circ\text{C}$ ,  $V_{CC} = 5\text{ V}$ ,  $V_{DD} = 3.3\text{ V}$ , master mode,  $f_S = 48\text{ kHz}$ , system clock =  $256 f_S$ , 24-bit data (unless otherwise noted).

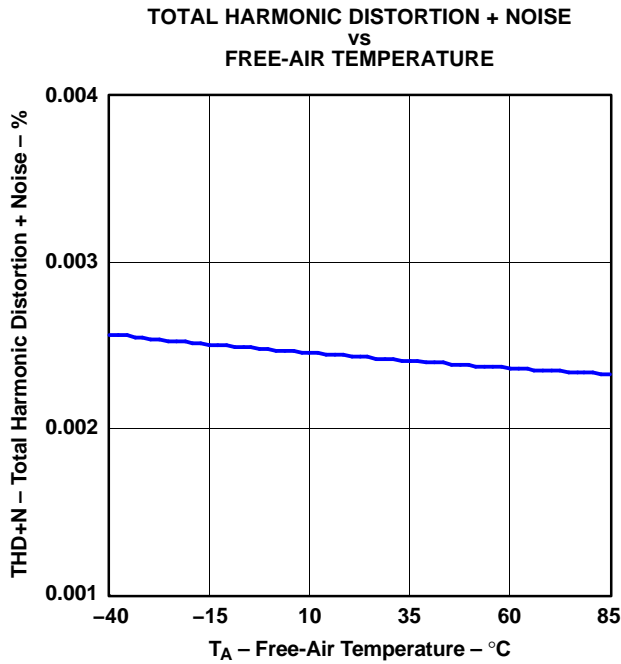

Figure 9.

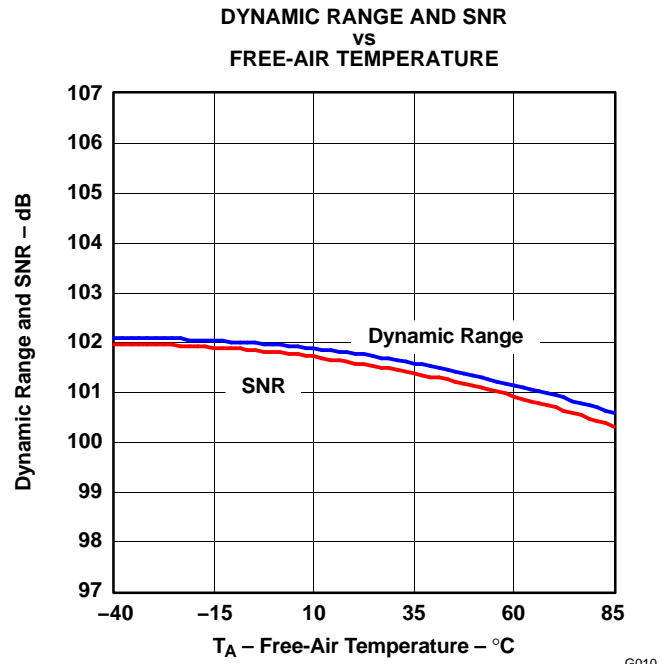

Figure 10.

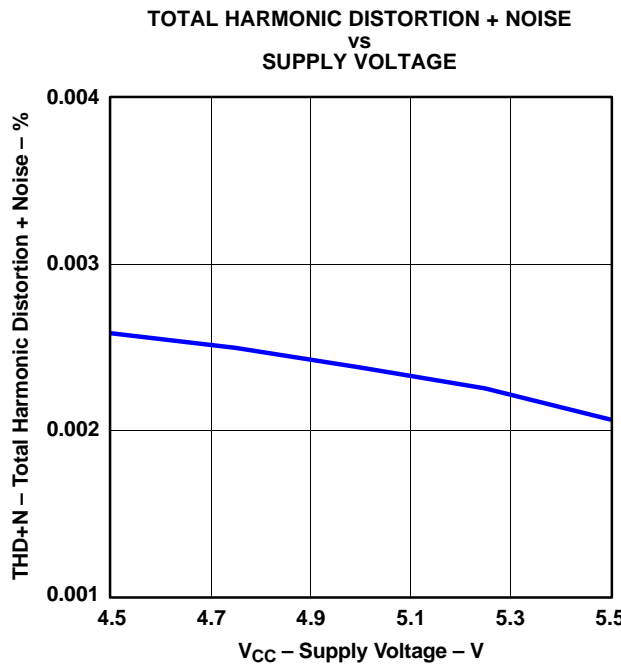

Figure 11.

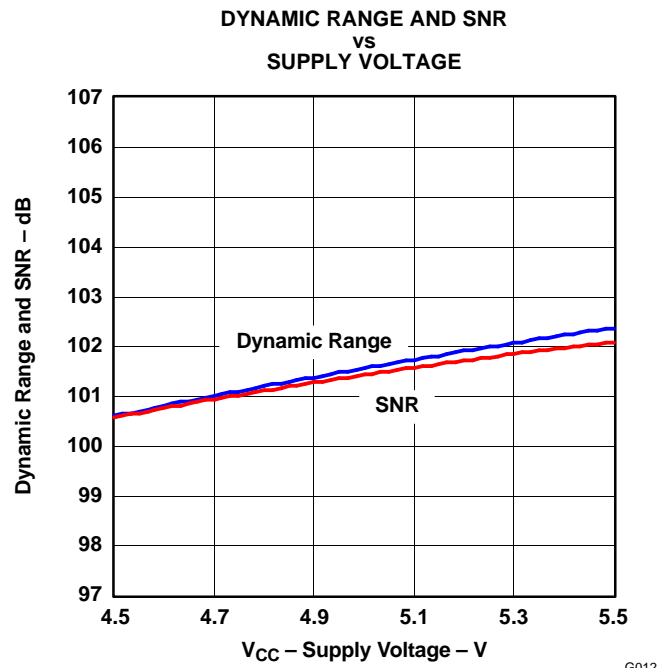

Figure 12.

TYPICAL PERFORMANCE CURVES AT PGA GAIN = -5.5 dB (continued)

All specifications at  $T_A = 25^\circ\text{C}$ ,  $V_{CC} = 5\text{ V}$ ,  $V_{DD} = 3.3\text{ V}$ , master mode,  $f_S = 48\text{ kHz}$ , system clock =  $256 f_S$ , 24-bit data (unless otherwise noted).

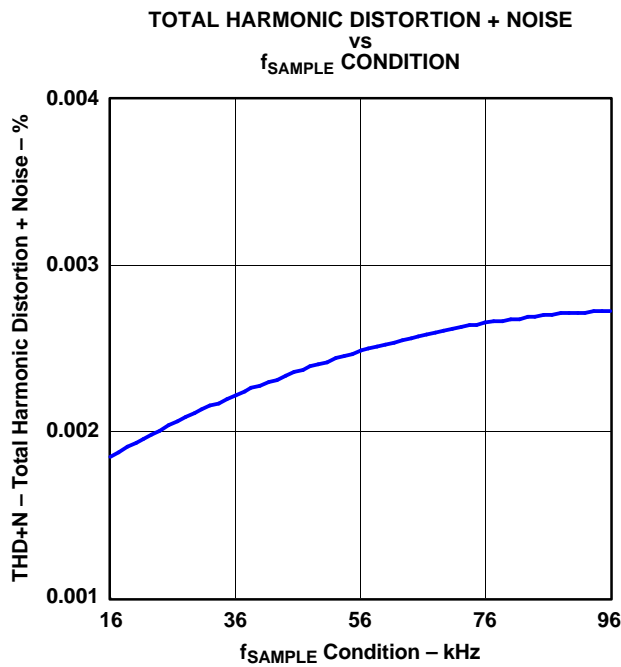

Figure 13.

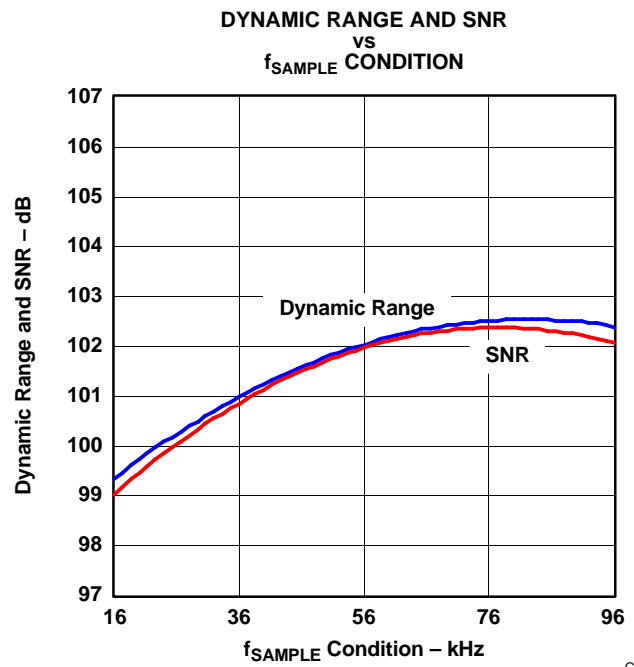

Figure 14.

OUTPUT SPECTRUM

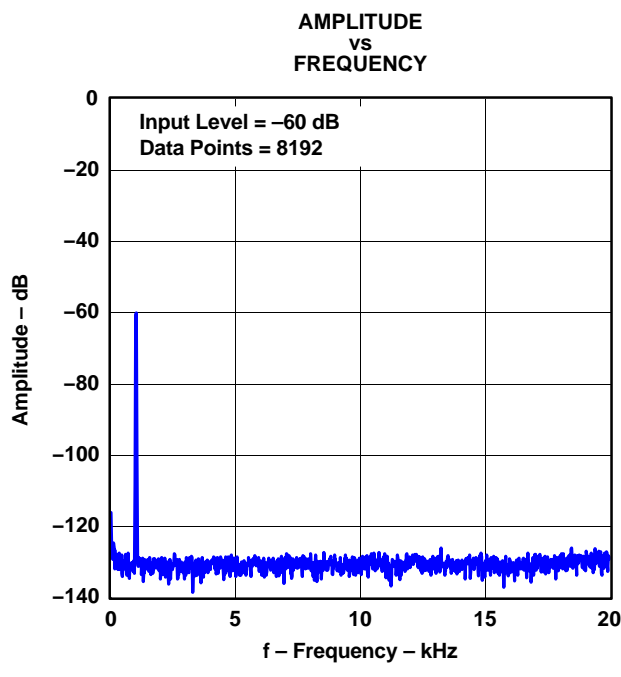

Figure 15.

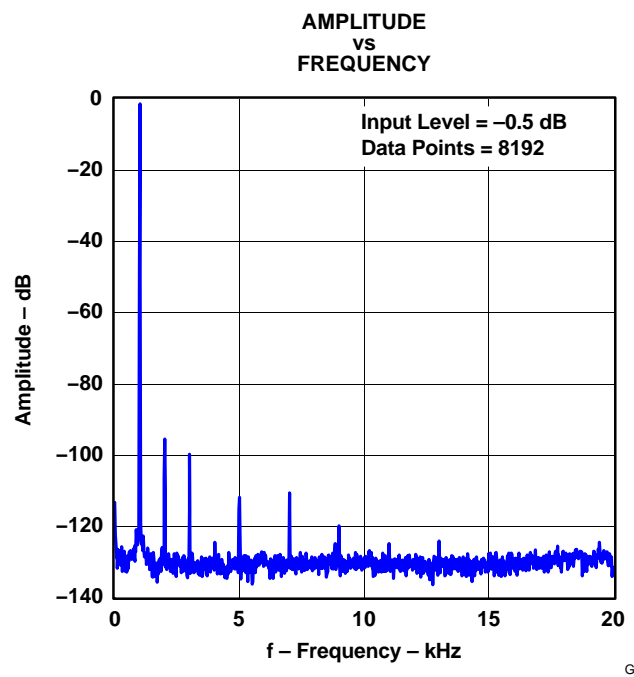

Figure 16.

**TYPICAL PERFORMANCE CURVES AT PGA GAIN = -5.5 dB (continued)**

All specifications at  $T_A = 25^\circ\text{C}$ ,  $V_{CC} = 5\text{ V}$ ,  $V_{DD} = 3.3\text{ V}$ , master mode,  $f_S = 48\text{ kHz}$ , system clock =  $256 f_S$ , 24-bit data (unless otherwise noted).

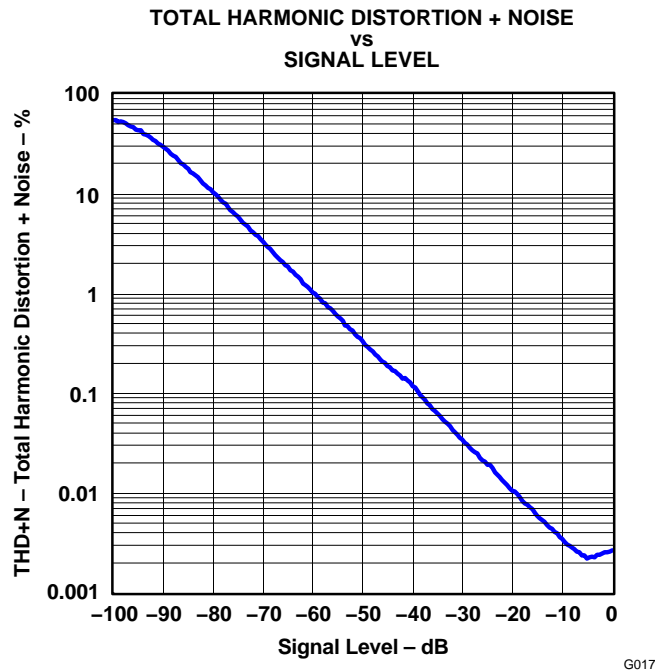

Figure 17.

**SUPPLY CURRENT**

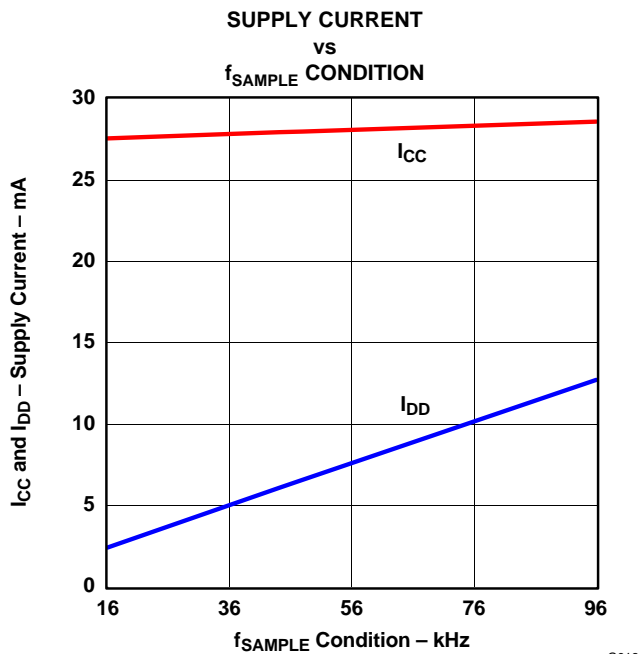

Figure 18.

**PGA GAIN LINEARITY**

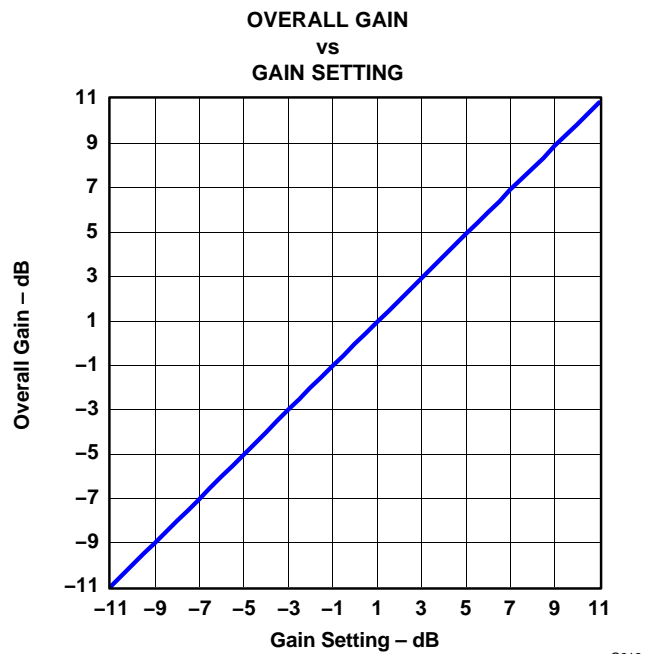

Figure 19.

## DETAILED DESCRIPTION

### SYSTEM CLOCK

The PCM1850A/1851A supports  $256 f_S$ ,  $384 f_S$ ,  $512 f_S$ , and  $768 f_S$  as the system clock, where  $f_S$  is the audio sampling frequency. The system clock must be supplied on SCKI (pin 7).

The PCM1850A/1851A has a system clock detection circuit which automatically senses if the system clock is operating at  $256 f_S$ ,  $384 f_S$ ,  $512 f_S$ , or  $768 f_S$  in slave mode. In master mode, the system clock frequency must be selected by mode control via the serial port. The  $768\text{-}f_S$  system clock is not available in master mode or for  $f_S = 88.2\text{ kHz}$  and  $96\text{ kHz}$  in the slave mode. The system clock is divided into  $128 f_S$  and  $64 f_S$  automatically, and these frequencies are used to operate the digital filter and the delta-sigma modulator, respectively.

Table 1 shows the relationship of typical sampling frequency to system clock frequency, and Figure 20 shows system clock timing.

**Table 1. Sampling Frequency and System Clock Frequency**

SAMPLING RATE FREQUENCY (kHz)	SYSTEM CLOCK FREQUENCY (MHz)			
	$256 f_S$	$384 f_S$	$512 f_S$	$768 f_S^{(1)}$
32	8.192	12.288	16.384	24.576
44.1	11.2896	16.9344	22.5792	33.8688
48	12.288	18.432	24.576	36.864
64	16.384	24.576	32.768	49.152
88.2	22.5792	33.8688	45.1584	—
96	24.576	36.864	49.152	—

(1) Slave mode only

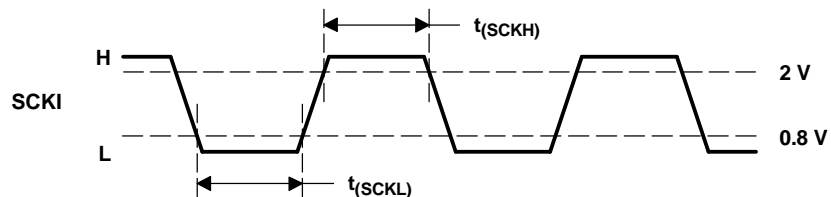

T0005-11

SYMBOL	PARAMETER	MIN	MAX	UNIT
$t_{(SCKH)}$	System clock pulse duration, HIGH	8		ns
$t_{(SCKL)}$	System clock pulse duration, LOW	8		ns

**Figure 20. System Clock Timing**

## POWER-ON-RESET SEQUENCE

The PCM1850A/1851A has an internal power-on-reset circuit, and initialization (reset) is performed automatically at the time that the power supply ( $V_{DD}$ ) exceeds 2.2 V (typical). While  $V_{DD} < 2.2$  V (typical) and for 1024 system clocks after  $V_{DD} > 2.2$  V (typical), the PCM1850A/1851A stays in the reset state and the digital output is forced to zero. The digital output is valid after the reset state is released and the time of  $4500/f_s$  has passed. At the moment of the power-on-reset release, the PCM1850A/1851A does not need a system clock. [Figure 21](#) illustrates the internal power-on-reset timing and the digital output for power-on reset.

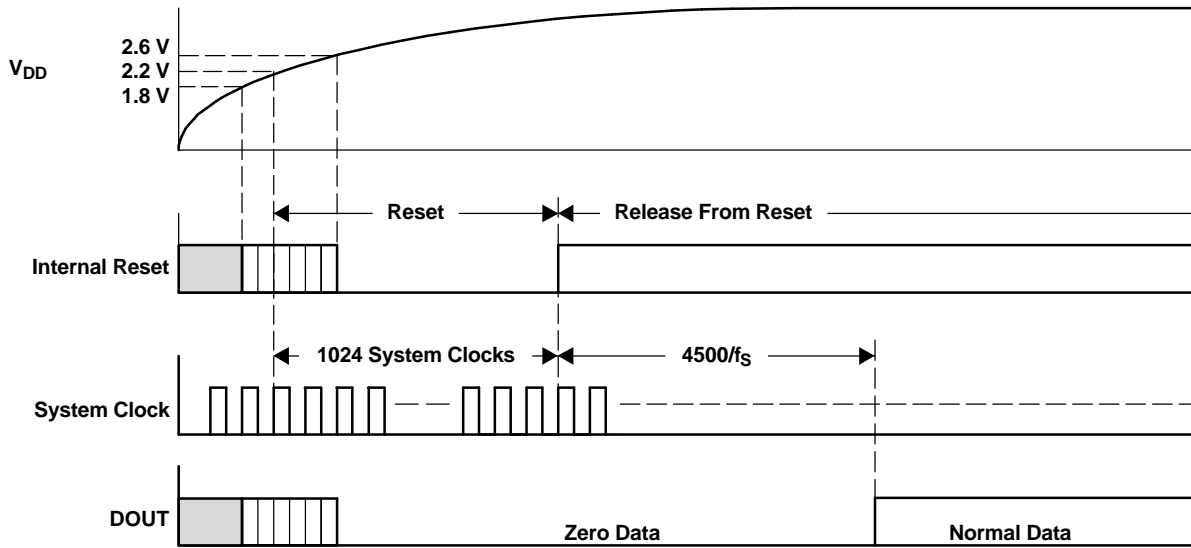

T0014-10

**Figure 21. Internal Power-On-Reset Timing**

## ANALOG FRONT END

The PCM1850A/1851A has a built-in analog front-end circuit, which is shown in the block diagram of Figure 22. Selection of the multiplexer input and PGA gain is controlled by mode control via the serial port as shown in Table 2 and Table 3. The change of the input selection and the gain selection is performed immediately after the serial control packet for the change is sent. A popping noise or other unexpected transient response could be generated in the audio signal during channel and gain change. Because the PCM1850A/1851A has no zero-cross detection and no other buffering capability for channel and gain change, appropriate data handling in the digital domain is recommended to control transients.

The PCM1850A/1851A analog front end permits only ac input via an input capacitor; dc input is prohibited. A signal source resistance of less than 1 k $\Omega$  is recommended for the V<sub>INxx</sub> pins.

All unselected channel inputs are terminated V<sub>REFS</sub> (= 0.5 V<sub>CC</sub>) using a resistor, typically 57 k $\Omega$ .

The PCM1850A/1851A employs MOUTL/R pins (pins 12 and 11) to monitor the multiplexer output. The load on these pins must be ac-coupled and not less than 10 k $\Omega$ . The full-scale output level is typically 0.6 V<sub>CC</sub>.

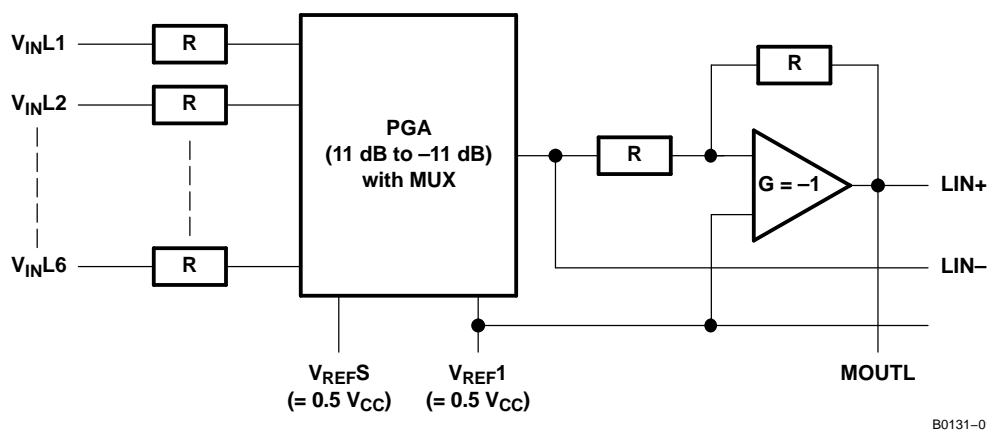

Figure 22. Analog Front-End Block Diagram (L-Channel)

Table 2. Multiplexer Input Selection

CH2	CH1	CH0	CHANNEL
0	0	0	Mute
0	0	1	Channel 1 (default)
0	1	0	Channel 2
0	1	1	Channel 3
1	0	0	Channel 4
1	0	1	Channel 5
1	1	0	Channel 6
1	1	1	Mute

**Table 3. PGA Gain Selection**

PG5	PG4	PG3	PG2	PG1	PG0	PGA GAIN [dB]	R <sub>IN</sub> [kΩ, Typical] <sup>(1)</sup>
0	0	1	0	1	0	-11 (default)	201
0	0	1	0	1	1	-10.5	199
0	0	1	1	0	0	-10	196
0	0	1	1	0	1	-9.5	193
0	0	1	1	1	0	-9	190
0	0	1	1	1	1	-8.5	188
0	1	0	0	0	0	-8	185
0	1	0	0	0	1	-7.5	181
0	1	0	0	1	0	-7	178
0	1	0	0	1	1	-6.5	175
0	1	0	1	0	0	-6	172
0	1	0	1	0	1	-5.5	169
0	1	0	1	1	0	-5	165
0	1	0	1	1	1	-4.5	162
0	1	1	0	0	0	-4	158
0	1	1	0	0	1	-3.5	155
0	1	1	0	1	0	-3	151
0	1	1	0	1	1	-2.5	147
0	1	1	1	0	0	-2	144
0	1	1	1	0	1	-1.5	140
0	1	1	1	1	0	-1	136
0	1	1	1	1	1	-0.5	133
1	0	0	0	0	0	0	129
1	0	0	0	0	1	0.5	125
1	0	0	0	1	0	1	122
1	0	0	0	1	1	1.5	118
1	0	0	1	0	0	2	114
1	0	0	1	0	1	2.5	111
1	0	0	1	1	0	3	107
1	0	0	1	1	1	3.5	103
1	0	1	0	0	0	4	100
1	0	1	0	0	1	4.5	96
1	0	1	0	1	0	5	93
1	0	1	0	1	1	5.5	89
1	0	1	1	0	0	6	86
1	0	1	1	0	1	6.5	83
1	0	1	1	1	0	7	80
1	0	1	1	1	1	7.5	77
1	1	0	0	0	0	8	73
1	1	0	0	0	1	8.5	70
1	1	0	0	1	0	9	68
1	1	0	0	1	1	9.5	65
1	1	0	1	0	0	10	62
1	1	0	1	0	1	10.5	59
1	1	0	1	1	0	11	57

(1)  $R_{IN}(k\Omega, \text{typical}) = 258 / (1 + 10^{\text{GAIN}/20})$   
 The PCM1850A/1851A becomes mute for PG[5:0] values other than those listed.

## SERIAL AUDIO DATA INTERFACE

The PCM1850A/1851A interfaces with the audio system through BCK (pin 2), LRCK (pin 1), and DOUT (pin 3).

### Interface Mode

The PCM1850A/1851A supports both master and slave modes as interface modes, and they are selected by mode control via the serial port as shown in [Table 4](#).

In master mode, the PCM1850A/1851A provides the timing for serial audio data communications between the PCM1850A/1851A and the digital audio processor or external circuit. While in slave mode, the PCM1850A/1851A receives the timing for data transfer from an external controller.

**Table 4. Interface Mode**

MD1	MD0	INTERFACE MODE
0	0	Slave mode (256 f <sub>S</sub> , 384 f <sub>S</sub> , 512 f <sub>S</sub> , 768 f <sub>S</sub> ) (default)
0	1	Master mode (256 f <sub>S</sub> )
1	0	Master mode (384 f <sub>S</sub> )
1	1	Master mode (512 f <sub>S</sub> )

### Master Mode

In master mode, BCK and LRCK work as output pins, and these pins are controlled by timing which is generated in the clock and timing control circuit of the PCM1850A/1851A. The frequency of BCK is fixed at 64 × LRCK. A 768-f<sub>S</sub> system clock is not available in master mode.

### Slave Mode

In slave mode, BCK and LRCK work as input pins. The PCM1850A/1851A accepts the 64 BCK/LRCK or 48 BCK/LRCK (only for 384 f<sub>S</sub> SCKI) format. A 768-f<sub>S</sub> system clock is not available for f<sub>S</sub> = 88.2 kHz and 96 kHz in slave mode.

### Data Format

The PCM1850A/1851A supports four audio data formats in both master and slave modes, and they are selected by mode control via the serial port as shown in [Table 5](#). [Figure 23](#) illustrates the data formats in both slave and master modes.

**Table 5. Data Format**

FORMAT NO.	FMT2	FMT1	FMT0	FORMAT
0	1	0	1	Left-justified, 24-bit
1	1	0	0	I <sup>2</sup> S, 24-bit, (default)
2	0	0	0	Right-justified, 24-bit
3	0	1	1	Right-justified, 16-bit

**FORMAT 0: FMT[2:0] = 101b**

24-Bit, MSB-First, Left-Justified

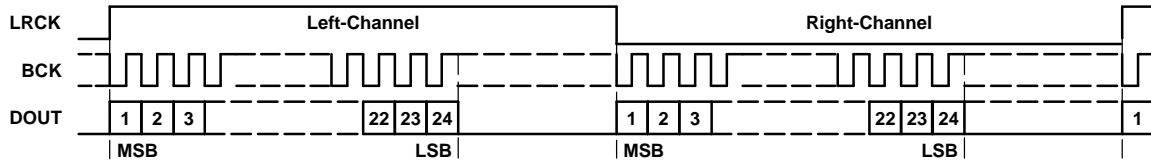

**FORMAT 1: FMT[2:0] = 100b**

24-Bit, MSB-First, I<sup>2</sup>S

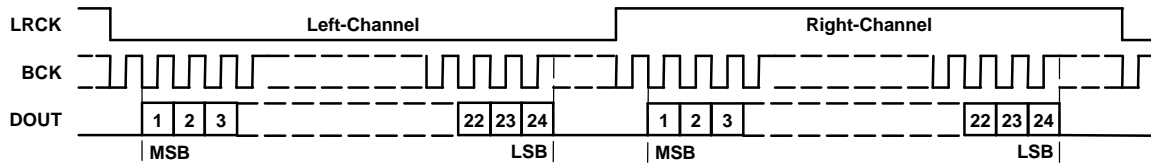

**FORMAT 2: FMT[2:0] = 000b**

24-Bit, MSB-First, Right-Justified

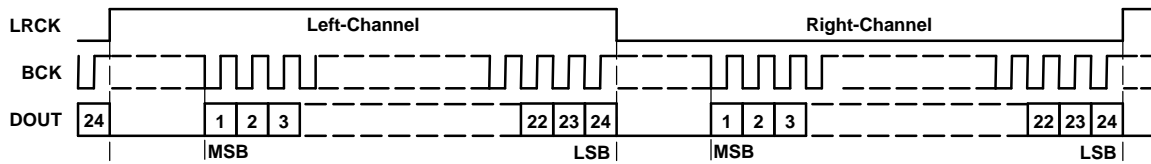

**FORMAT 3: FMT[2:0] = 011b**

16-Bit, MSB-First, Right-Justified

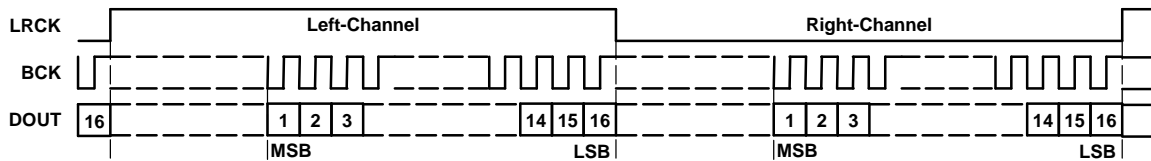

T0016-16

**Figure 23. Audio Data Format (LRCK, BCK Work as Inputs in Slave Mode and Outputs in Master Mode)**

## Interface Timing

Figure 24 and Figure 25 illustrate the interface timing in slave and master modes, respectively.

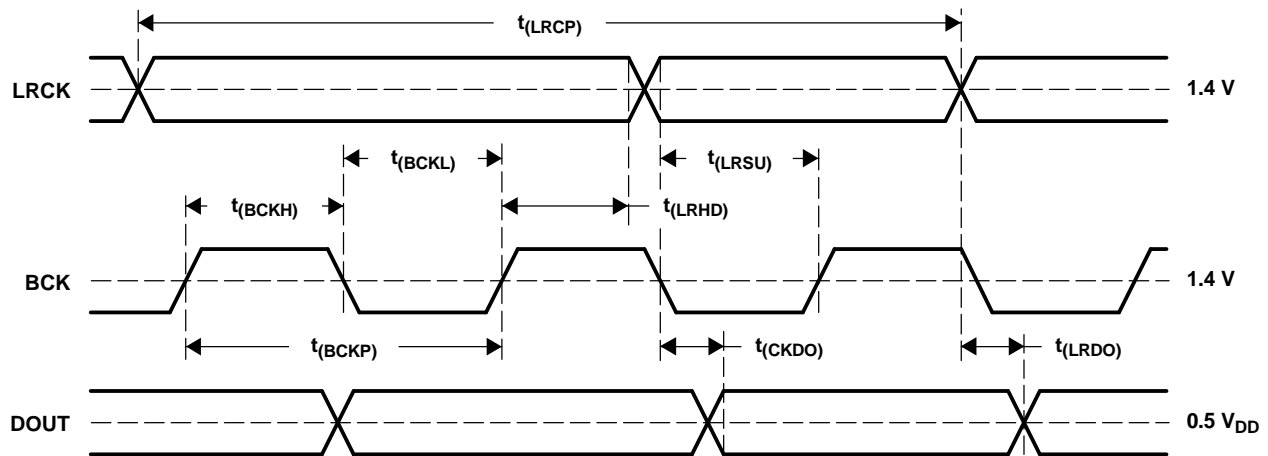

T0017-02

SYMBOL	PARAMETER	MIN	TYP	MAX	UNIT
$t_{(BCKP)}$	BCK period	150			ns
$t_{(BCKH)}$	BCK pulse duration, HIGH	60			ns
$t_{(BCKL)}$	BCK pulse duration, LOW	60			ns
$t_{(LRSU)}$	LRCK setup time to BCK rising edge	20			ns
$t_{(LRHD)}$	LRCK hold time to BCK rising edge	20			ns
$t_{(LRCP)}$	LRCK period	10			$\mu$ s
$t_{(CKDO)}$	Delay time, BCK falling edge to DOUT valid	-10		20	ns
$t_{(LRDO)}$	Delay time, LRCK edge to DOUT valid	-10		20	ns
$t_r$	Rise time of all signals			10	ns
$t_f$	Fall time of all signals			10	ns

NOTE: Timing measurement reference level is 1.4 V for input and 0.5  $V_{DD}$  for output. Rise and fall times are measured from 10% to 90% of IN/OUT signal swing. Load capacitance of DOUT is 20 pF.

**Figure 24. Audio Data Interface Timing (Slave Mode: LRCK, BCK Work as Inputs)**

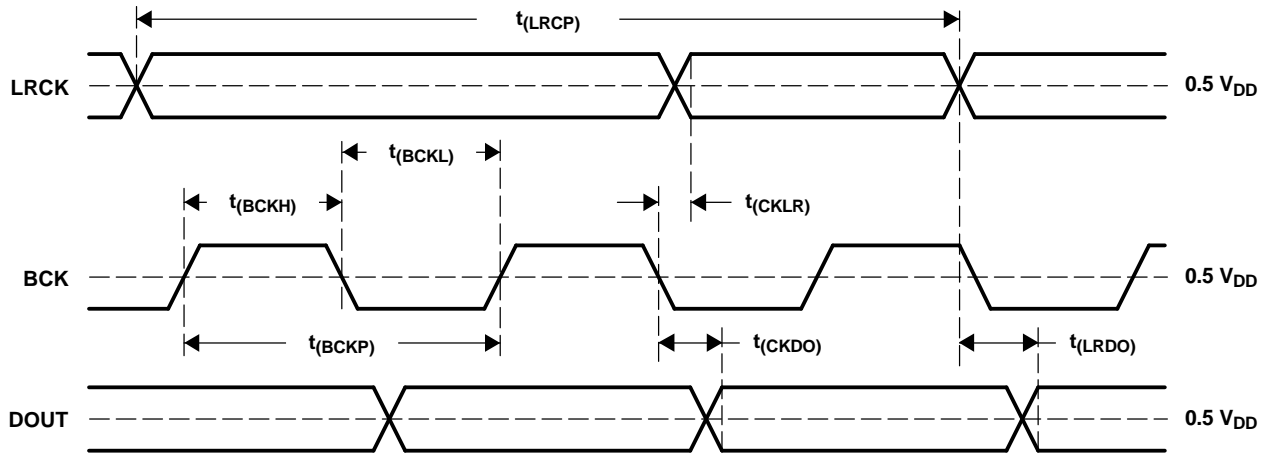

T0018-02

SYMBOL	PARAMETER	MIN	TYP	MAX	UNIT
$t_{(BCKP)}$	BCK period	150	$1/(64 f_S)$	1000	ns
$t_{(BCKH)}$	BCK pulse duration, HIGH	60	$0.5 t_{(BCKP)}$	400	ns
$t_{(BCKL)}$	BCK pulse duration, LOW	60	$0.5 t_{(BCKP)}$	400	ns
$t_{(CKLR)}$	Delay time, BCK falling edge to LRCK valid	-10		20	ns
$t_{(LRCP)}$	LRCK period	10	$1/f_S$	60	$\mu s$
$t_{(CKDO)}$	Delay time, BCK falling edge to DOUT valid	-10		20	ns
$t_{(LRDO)}$	Delay time, LRCK edge to DOUT valid	-10		20	ns
$t_r$	Rise time of all signals			10	ns
$t_f$	Fall time of all signals			10	ns

NOTE: Timing measurement reference level is  $0.5 V_{DD}$ . Rise and fall times are measured from 10% to 90% of IN/OUT signal swing. Load capacitance of all signals is 20 pF.

**Figure 25. Audio Data Interface Timing (Master Mode: LRCK, BCK Work as Outputs)**

## SYNCHRONIZATION WITH DIGITAL AUDIO SYSTEM

In slave mode, the PCM1850A/1851A operates under LRCK, synchronized with system clock SCKI. The PCM1850A/1851A does not need a specific phase relationship between LRCK and SCKI, but does require the synchronization of LRCK and SCKI.

If the relationship between LRCK and SCKI changes more than  $\pm 6$  BCKs for 64 BCKs/frame ( $\pm 5$  BCKs for 48 BCKs/frame) during one sample period due to LRCK or SCKI jitter, internal operation of the ADC halts within  $1/f_s$  and digital output is forced into the BPZ code until resynchronization between LRCK and SCKI is completed.

In the case of changes less than  $\pm 5$  BCKs for 64 BCKs/frame ( $\pm 4$  BCKs for 48 BCKs/frame), resynchronization with simultaneous discontinuity in the digital output does not occur.

Figure 26 illustrates the digital output response for loss of synchronization and resynchronization. During undefined data, the PCM1850A/1851A might generate some noise in the audio signal. Also, the transition of normal to undefined data and undefined or zero data to normal creates a discontinuity of data in the digital output, which could generate some noise in the audio signal.

It is recommended to set  $\overline{\text{RST}}$  (pin 10) to LOW to get stable analog performance when the sampling rate, interface mode, or data format is changed.

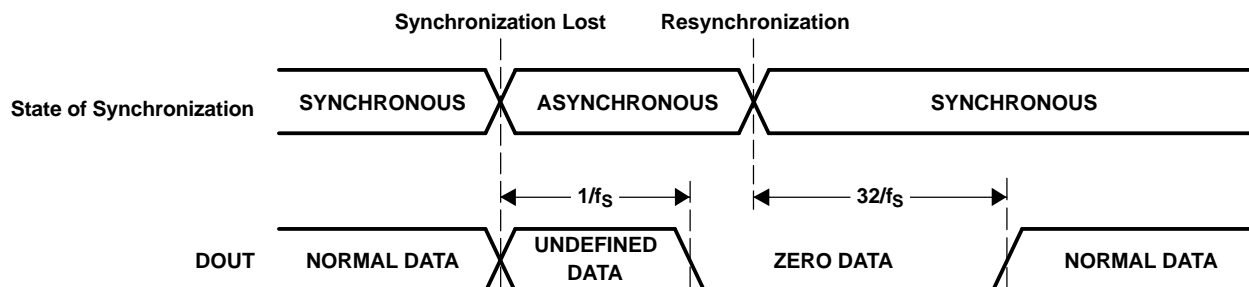

T0020-05

Figure 26. ADC Digital Output for Loss of Synchronization and Resynchronization

### Power-Down Control

$\overline{\text{RST}}$  (pin 10) controls the entire ADC operation. During reset mode, the supply current of the analog section is shut off and the digital section is initialized. DOUT (pin 3) is also disabled. Halting SCKI, BCK, and LRCK is recommended to minimize power dissipation.

$\overline{\text{RST}}$	POWER-DOWN MODE
LOW	Reset and power-down modes
HIGH	Normal operation mode

### Overflow Flag Output

The PCM1850A/1851A has an output flag (pin 4) that indicates when overflow occurs in the L-channel or R-channel, and this flag remains HIGH at least during the  $8192/f_s$  time for a momentary overflow occurrence.

### HPF Bypass Control

The built-in HPF function for dc component rejection can be bypassed via the serial port. In bypass mode, the dc component of the analog input signal, the internal dc offset, etc., are converted and included in the digital output data.

BYP	HPF (HIGH-PASS FILTER) MODE
0	Normal (no dc component on DOUT) mode (default)
1	Bypass (dc component on DOUT) mode

## System Reset Control

The system reset control is used to resynchronize the system via the serial port when the system clock frequency, interface mode, and data format are changed. Change them while SRST = LOW. If they are changed during normal operation, analog performance can be degraded.

SRST	SYSTEM RESET
0	Resynchronization
1	Normal operation (default)

## Mode Register Reset Control

The MRST bit is used to reset the mode control register to its default settings via the serial port.

MRST	MODE REGISTER RESET
0	Set default value
1	Normal operation (default)

## SPI SERIAL CONTROL PORT FOR MODE CONTROL (PCM1850A)

The user-programmable built-in functions of the PCM1850A can be controlled through a serial control port with the SPI format. All operations for the serial control port use 16-bit data words. Figure 27 shows the control data word format. The most-significant bit must be set to 0. Seven bits, labeled IDX[6:0], set the register index (or address) for write operations. The least-significant eight bits, D[7:0], contain the data to be written to the register specified by IDX[6:0].

Figure 28 shows the functional timing diagram for writing to the serial control port. MS (pin 30) is held at a logic-1 state until a register needs to be written. To start the register write cycle, MS is set to logic-0. Sixteen clocks are then provided on MC (pin 31), corresponding to the 16 bits of the control data word on MD (pin 32). After the sixteenth clock cycle has completed, the data is latched into the indexed mode control register in the write operation. To write the next data word, MS must be set to 1 once.

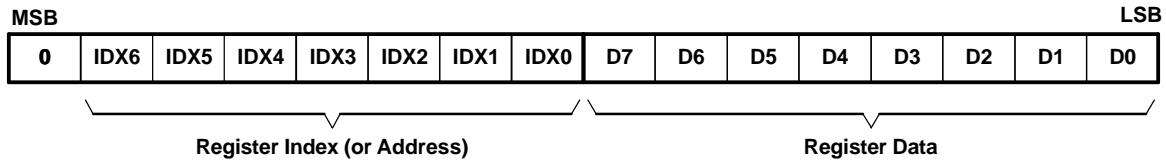

Figure 27. Control Data Word Format for MD

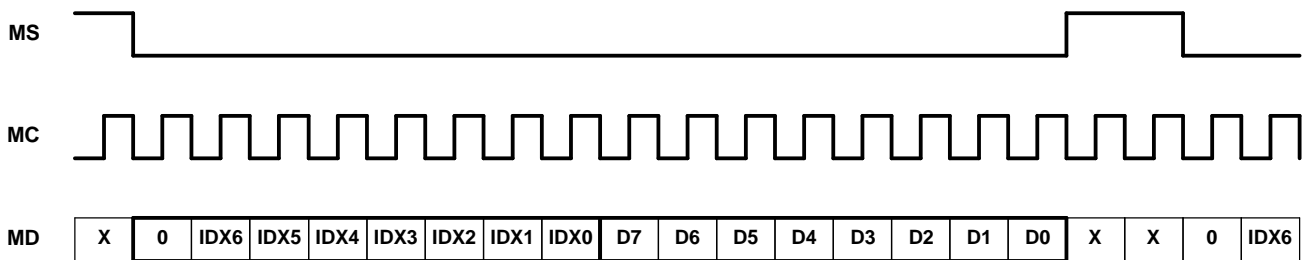
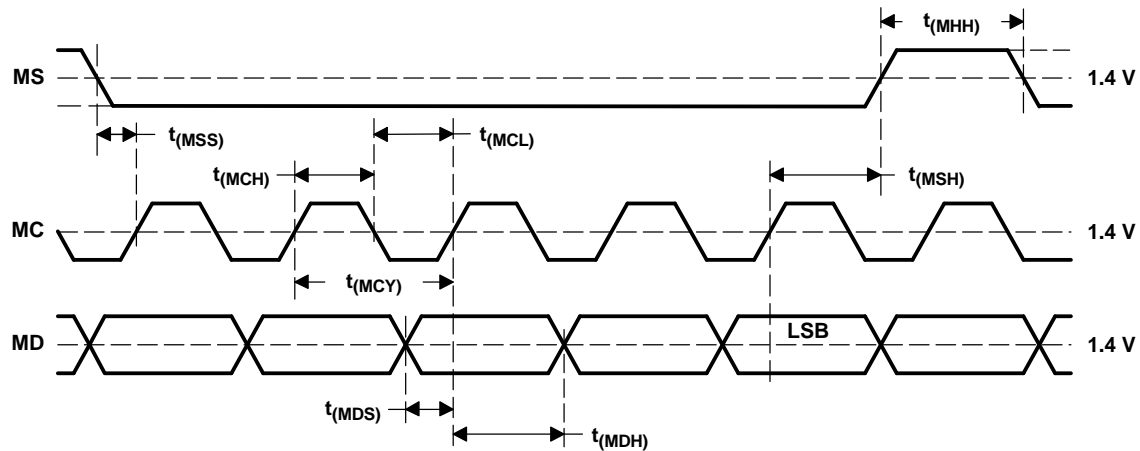

Figure 28. Serial Control Format

## CONTROL INTERFACE TIMING REQUIREMENTS (PCM1850A)

Figure 29 shows a detailed timing diagram for the serial control interface of the PCM1850A. These timing parameters are critical for proper control port operation.



T0013-06

SYMBOL	PARAMETER	MIN	MAX	UNIT
$t_{(MCY)}$	MC pulse cycle time	100		ns
$t_{(MCL)}$	MC LOW-level time	40		ns
$t_{(MCH)}$	MC HIGH-level time	40		ns
$t_{(MHH)}$	MS HIGH-level time	80		ns
$t_{(MSS)}$	MS falling edge to MC rising edge	15		ns
$t_{(MSH)}$	MS hold time <sup>(1)</sup>	15		ns
$t_{(MDH)}$	MD hold time	15		ns
$t_{(MDS)}$	MD setup time	15		ns

(1) MC rising edge for LSB to MS rising edge

Figure 29. PCM1850A Control Interface Timing

## I<sup>2</sup>C SERIAL CONTROL PORT FOR MODE CONTROL (PCM1851A)

The user-programmable built-in function of the PCM1851A can be controlled through the I<sup>2</sup>C-format serial control port, SDA (pin 32) and SCL (pin 31). The PCM1851A supports the I<sup>2</sup>C serial bus and the data transmission protocol for standard mode as a slave device. This protocol is explained in I<sup>2</sup>C specification 2.0.

### Slave Address

MSB						LSB	
1	0	0	1	0	1	ADR	R/nW

The PCM1851A has 7 bits for its own slave address. The first six bits (MSBs) of the slave address are factory preset to 100101. The last bit of the address byte is the device select bit, which can be user-defined by the ADR pin (pin 30). A maximum of two PCM1851As can be connected on the same bus at one time. Each PCM1851A responds when it receives its own slave address.

### Packet Protocol

A master device must control packet protocol, which consists of start condition, slave address with read/write bit, data if write or acknowledgement if read, and stop condition. The PCM1851A supports only slave receivers, so the R/ $\overline{W}$  bit must be set to 0.



**TIMING DIAGRAM**

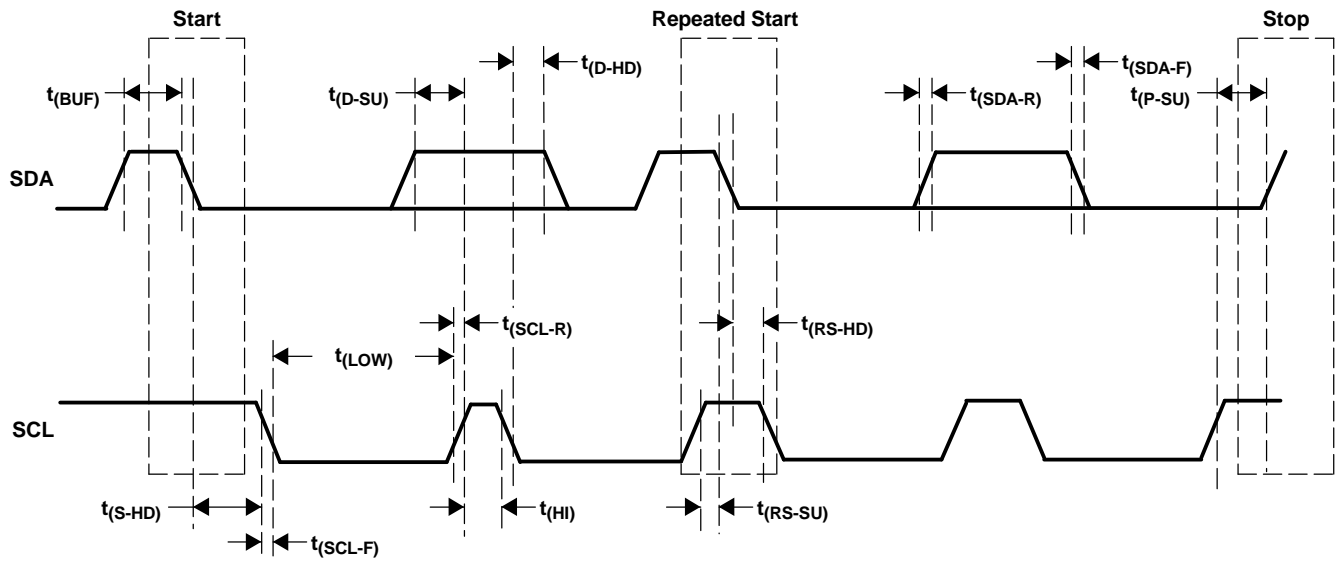

T0050-01

SYMBOL	PARAMETER	MIN	MAX	UNIT
$f_{(SCL)}$	SCL clock frequency		100	kHz
$t_{(BUF)}$	Bus free time between STOP and START conditions	4.7		$\mu$ s
$t_{(LOW)}$	Low period of the SCL clock	4.7		$\mu$ s
$t_{(HI)}$	High period of the SCL clock	4		$\mu$ s
$t_{(RS-SU)}$	Setup time for START/repeated START condition	4.7		$\mu$ s
$t_{(S-HD)}, t_{(RS-HD)}$	Hold time for START/repeated START condition	4		$\mu$ s
$t_{(D-SU)}$	Data setup time	250		ns
$t_{(D-HD)}$	Data hold time	0	900	ns
$t_{(SCL-R)}$	Rise time of SCL signal	$20 + 0.1 C_B$	1000	ns
$t_{(SCL-F)}$	Fall time of SCL signal	$20 + 0.1 C_B$	1000	ns
$t_{(SDA-R)}$	Rise time of SDA signal	$20 + 0.1 C_B$	1000	ns
$t_{(SDA-F)}$	Fall time of SDA signal	$20 + 0.1 C_B$	1000	ns
$t_{(P-SU)}$	Setup time for STOP condition	4		$\mu$ s
$C_B$	Capacitive load for SDA and SCL lines		400	pF
$V_{NH}$	Noise margin at HIGH level for each connected device (including hysteresis)	$0.2 V_{DD}$		V

**Figure 32. PCM1851A Control Interface Timing Requirements**

## MODE CONTROL REGISTERS

### User-Programmable Mode Control Functions

The PCM1850A/1851A has several user-programmable functions which are accessed via control registers. The registers are programmed using the serial control port which is discussed in the *SPI Serial Control Port for Mode Control (PCM1850A)* and *I<sup>2</sup>C Serial Control Port for Mode Control (PCM1851A)* sections of this data sheet. [Table 6](#) lists the available mode control functions, along with their reset default conditions and associated register index.

### Register Map

The mode control register map is shown in [Table 7](#). Each register includes an index (or address) indicated by the  $IDX[6:0]$  bits  $B[14:8]$ .

**Table 6. User-Programmable Mode Control Functions**

FUNCTION	RESET DEFAULT	REGISTER	BIT(S)
Mode register reset	Normal operation	31	MRST
PGA gain control	–11 dB	31	PG[5:0]
Multiplexer input channel control	Channel 1	32	CH[2:0]
HPF bypass control	HPF enable	33	BYP
System reset	Normal operation	33	SRST
Audio interface mode control	Slave	33	MD[1:0]
Audio interface format control	I <sup>2</sup> S	33	FMT[2:0]

**Table 7. Mode Control Register Map**

HEX	B15	B14	B13	B12	B11	B10	B9	B8	B7	B6	B5	B4	B3	B2	B1	B0
Register 31	0	0	1	1	0	0	0	1	RSV <sup>(1)</sup>	MRST	PG5	PG4	PG3	PG2	PG1	PG0
Register 32	0	0	1	1	0	0	1	0	RSV <sup>(1)</sup>	RSV <sup>(1)</sup>	RSV <sup>(1)</sup>	RSV <sup>(1)</sup>	RSV <sup>(1)</sup>	CH2	CH1	CH0
Register 33	0	0	1	1	0	0	1	1	BYP	SRST	RSV <sup>(1)</sup>	MD1	MD0	FMT2	FMT1	FMT0

(1) RSV bits must be always written as 0. No values can be written in address 30h.

## APPLICATION INFORMATION

### TYPICAL CIRCUIT CONNECTION DIAGRAM

The following figure illustrates a typical circuit connection diagram for six stereo inputs and an analog monitor.

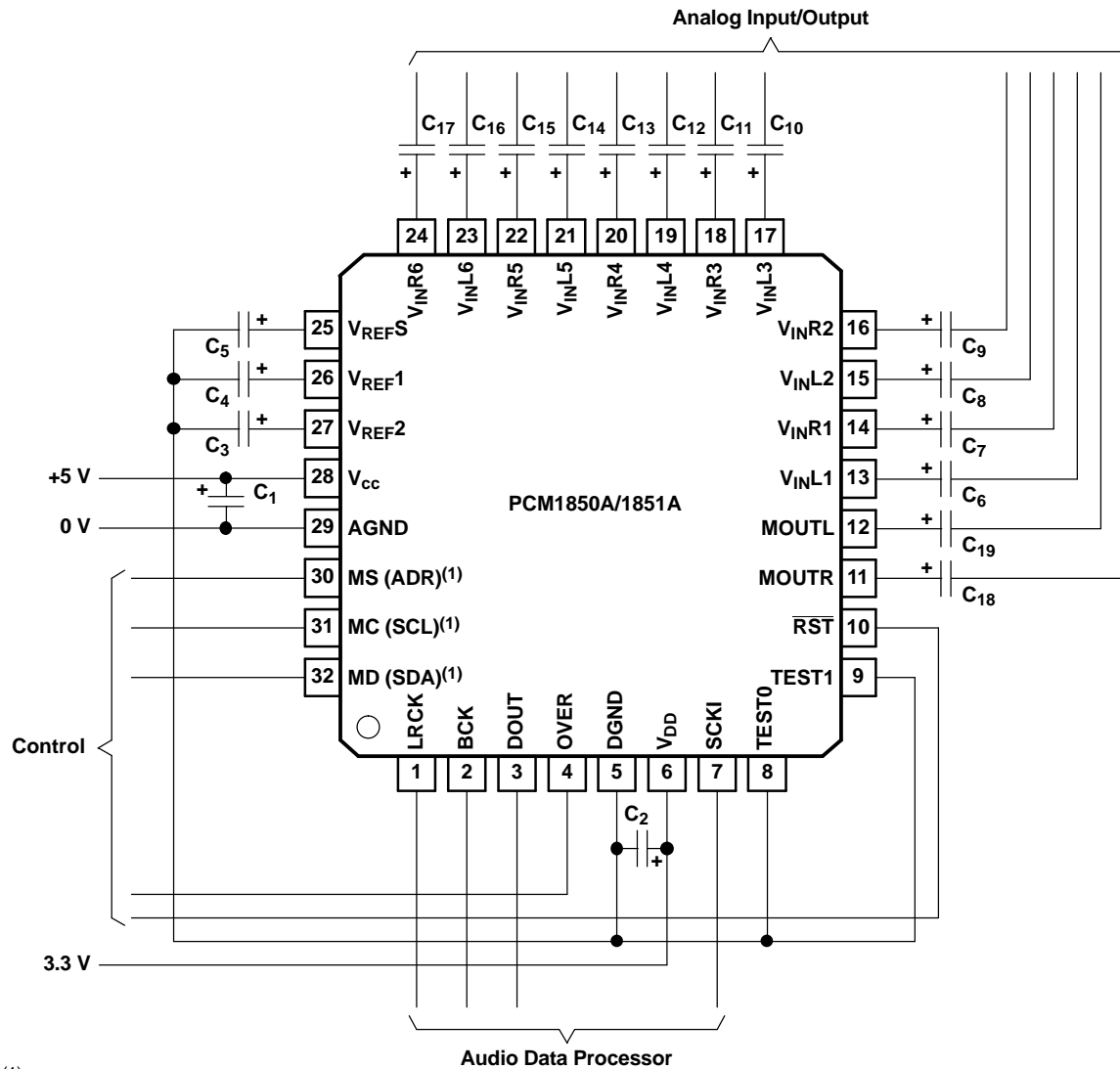

(1) PCM1850A (PCM1851A)

S0181-01

NOTE:  $C_1, C_2$ : 0.1- $\mu\text{F}$  ceramic and 10- $\mu\text{F}$  electrolytic capacitors are recommended, depending on layout and power supply.  
 $C_3, C_4, C_5$ : 0.1- $\mu\text{F}$  ceramic and 10- $\mu\text{F}$  electrolytic capacitors are recommended.  
 $C_6$ – $C_{17}$ : A 0.33- $\mu\text{F}$  capacitor gives a 2.9-Hz ( $\tau = 0.33 \mu\text{F} \times 169 \text{ k}\Omega$ ) typical cutoff frequency at the HPF input in normal operation, and it requires power-on settling time with a 56-ms time constant in the power-on initialization period. Cutoff frequency and time constant depend on PGA gain. Cutoff frequency varies from 2.4 Hz to 8.5 Hz for 0.33  $\mu\text{F}$ . DC-coupled input is inhibited for the analog input,  $V_{\text{INL}}[1:6]$  and  $V_{\text{INR}}[1:6]$ .  
 $C_{18}$ – $C_{19}$ : A 2.2- $\mu\text{F}$  capacitor with a 10-k $\Omega$  load gives a 7.2-Hz cutoff frequency.

---

**APPLICATION INFORMATION (continued)****BOARD DESIGN AND LAYOUT CONSIDERATIONS** **$V_{CC}$ ,  $V_{DD}$  Pins**

The digital and analog power supply lines to the PCM1850A/1851A must be bypassed to the corresponding ground pins with 0.1- $\mu$ F ceramic and 10- $\mu$ F electrolytic capacitors as close to the pins as possible to maximize the dynamic performance of the ADC.

**AGND, DGND Pins**

To maximize the dynamic performance of the PCM1850A/1851A, the analog and digital grounds are not connected internally. These grounds must have low impedance to avoid digital noise feeding back into the analog ground. Therefore, they should be connected directly to each other under the parts to reduce the potential of a noise problem.

 **$V_{INL}[1:6]$ ,  $V_{INR}[1:6]$  Pins**

A 0.33- $\mu$ F capacitor is recommended as the ac-coupling capacitor, which gives a 2.4- to 8.5-Hz cutoff frequency. If higher full-scale input voltage is required, it can be adjusted by adding only one series resistor to each  $V_{INxx}$  pin, but a signal source resistance less than 1 k $\Omega$  is recommended for these pins in order to keep accuracy of the gain control command and to maintain crosstalk performance.

**MOU<sub>T</sub>L, MOU<sub>T</sub>R Pins**

An ac-coupled light load is recommended; a 2.2- $\mu$ F capacitor with a 10-k $\Omega$  load gives a 7.2-Hz cutoff frequency.

 **$V_{REF1}$ ,  $V_{REF2}$ ,  $V_{REFS}$  Pins**

Between  $V_{REF1}$  and AGND,  $V_{REF2}$  and AGND, and  $V_{REFS}$  and AGND, 0.1- $\mu$ F ceramic and 10- $\mu$ F electrolytic capacitors are recommended to ensure low source impedance of the ADC references. These capacitors should be located as close as possible to the  $V_{REF1}$ ,  $V_{REF2}$ , and  $V_{REFS}$  pins to reduce dynamic errors on the ADC references. The differential voltage between  $V_{REF2}$  and AGND sets the analog input full-scale range.

**BCK and LRCK Pins (in Master Mode), DOUT Pin**

These pins have enough load-driving capability. However, if the output line is long, locating a buffer near the PCM1850A/1851A and minimizing load capacitance is recommended in order to minimize the digital-analog crosstalk and maximize the dynamic performance of the ADC.

**System Clock**

Because the PCM1850A/1851A operates based on a system clock, the quality of the system clock can influence dynamic performance. Therefore, it is recommended to consider the system clock duty, jitter, and the time difference between the system clock transition and the BCK or LRCK transition in slave mode.

**PACKAGING INFORMATION**

Orderable Device	Status <sup>(1)</sup>	Package Type	Package Drawing	Pins	Package Qty	Eco Plan <sup>(2)</sup>	Lead/Ball Finish	MSL Peak Temp <sup>(3)</sup>
PCM1850APJT	ACTIVE	TQFP	PJT	32	250	Green (RoHS & no Sb/Br)	CU NIPDAU	Level-1-260C-UNLIM
PCM1850APJTG4	ACTIVE	TQFP	PJT	32	250	Green (RoHS & no Sb/Br)	CU NIPDAU	Level-1-260C-UNLIM
PCM1850APJTR	ACTIVE	TQFP	PJT	32	1000	Green (RoHS & no Sb/Br)	CU NIPDAU	Level-1-260C-UNLIM
PCM1850APJTRG4	ACTIVE	TQFP	PJT	32	1000	Green (RoHS & no Sb/Br)	CU NIPDAU	Level-1-260C-UNLIM
PCM1851APJT	ACTIVE	TQFP	PJT	32	250	Green (RoHS & no Sb/Br)	CU NIPDAU	Level-1-260C-UNLIM
PCM1851APJTG4	ACTIVE	TQFP	PJT	32	250	Green (RoHS & no Sb/Br)	CU NIPDAU	Level-1-260C-UNLIM
PCM1851APJTR	ACTIVE	TQFP	PJT	32	1000	Green (RoHS & no Sb/Br)	CU NIPDAU	Level-1-260C-UNLIM
PCM1851APJTRG4	ACTIVE	TQFP	PJT	32	1000	Green (RoHS & no Sb/Br)	CU NIPDAU	Level-1-260C-UNLIM

<sup>(1)</sup> The marketing status values are defined as follows:

**ACTIVE:** Product device recommended for new designs.

**LIFEBUY:** TI has announced that the device will be discontinued, and a lifetime-buy period is in effect.

**NRND:** Not recommended for new designs. Device is in production to support existing customers, but TI does not recommend using this part in a new design.

**PREVIEW:** Device has been announced but is not in production. Samples may or may not be available.

**OBSELETE:** TI has discontinued the production of the device.

<sup>(2)</sup> Eco Plan - The planned eco-friendly classification: Pb-Free (RoHS), Pb-Free (RoHS Exempt), or Green (RoHS & no Sb/Br) - please check <http://www.ti.com/productcontent> for the latest availability information and additional product content details.

**TBD:** The Pb-Free/Green conversion plan has not been defined.

**Pb-Free (RoHS):** TI's terms "Lead-Free" or "Pb-Free" mean semiconductor products that are compatible with the current RoHS requirements for all 6 substances, including the requirement that lead not exceed 0.1% by weight in homogeneous materials. Where designed to be soldered at high temperatures, TI Pb-Free products are suitable for use in specified lead-free processes.

**Pb-Free (RoHS Exempt):** This component has a RoHS exemption for either 1) lead-based flip-chip solder bumps used between the die and package, or 2) lead-based die adhesive used between the die and leadframe. The component is otherwise considered Pb-Free (RoHS compatible) as defined above.

**Green (RoHS & no Sb/Br):** TI defines "Green" to mean Pb-Free (RoHS compatible), and free of Bromine (Br) and Antimony (Sb) based flame retardants (Br or Sb do not exceed 0.1% by weight in homogeneous material)

<sup>(3)</sup> MSL, Peak Temp. -- The Moisture Sensitivity Level rating according to the JEDEC industry standard classifications, and peak solder temperature.

**Important Information and Disclaimer:**The information provided on this page represents TI's knowledge and belief as of the date that it is provided. TI bases its knowledge and belief on information provided by third parties, and makes no representation or warranty as to the accuracy of such information. Efforts are underway to better integrate information from third parties. TI has taken and continues to take reasonable steps to provide representative and accurate information but may not have conducted destructive testing or chemical analysis on incoming materials and chemicals. TI and TI suppliers consider certain information to be proprietary, and thus CAS numbers and other limited information may not be available for release.

In no event shall TI's liability arising out of such information exceed the total purchase price of the TI part(s) at issue in this document sold by TI to Customer on an annual basis.

**TAPE AND REEL INFORMATION**

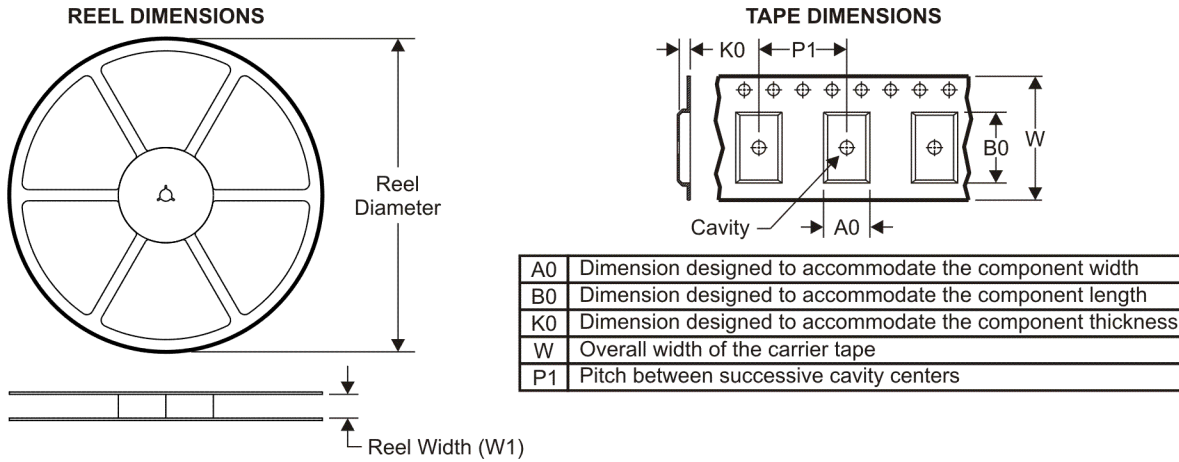

**QUADRANT ASSIGNMENTS FOR PIN 1 ORIENTATION IN TAPE**

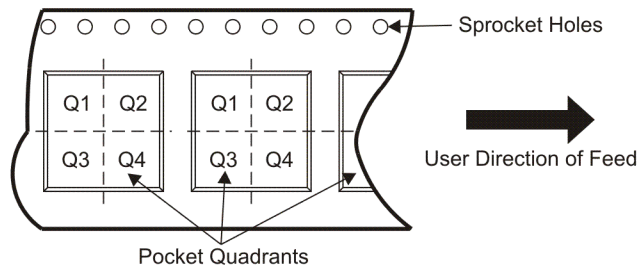

\*All dimensions are nominal

Device	Package Type	Package Drawing	Pins	SPQ	Reel Diameter (mm)	Reel Width W1 (mm)	A0 (mm)	B0 (mm)	K0 (mm)	P1 (mm)	W (mm)	Pin1 Quadrant
PCM1851APJTR	TQFP	PJT	32	1000	330.0	16.8	9.6	9.6	1.5	12.0	16.0	Q2

**TAPE AND REEL BOX DIMENSIONS**

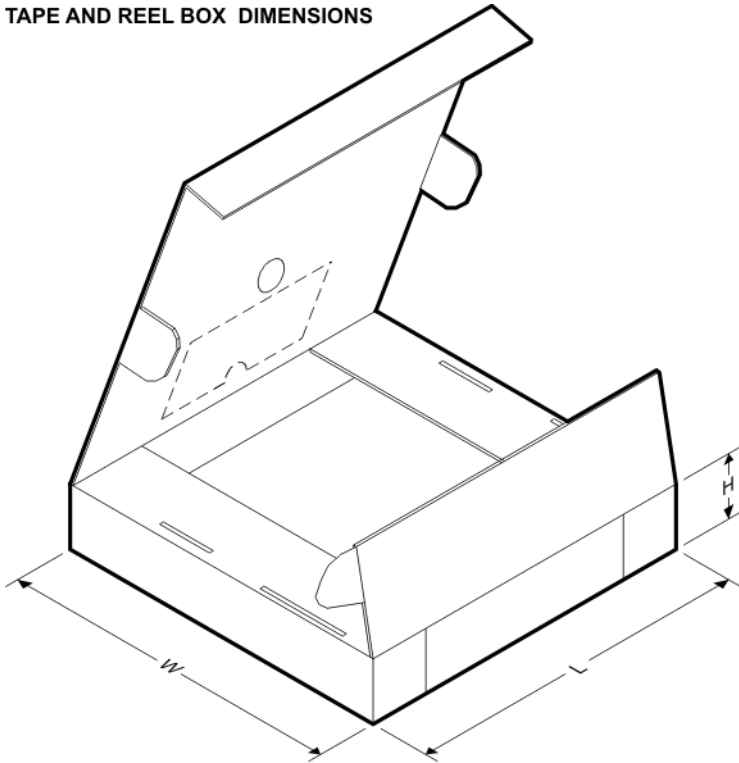

\*All dimensions are nominal

Device	Package Type	Package Drawing	Pins	SPQ	Length (mm)	Width (mm)	Height (mm)
PCM1851APJTR	TQFP	PJT	32	1000	346.0	346.0	33.0

PJT (S-PQFP-N32)

PLASTIC QUAD FLATPACK

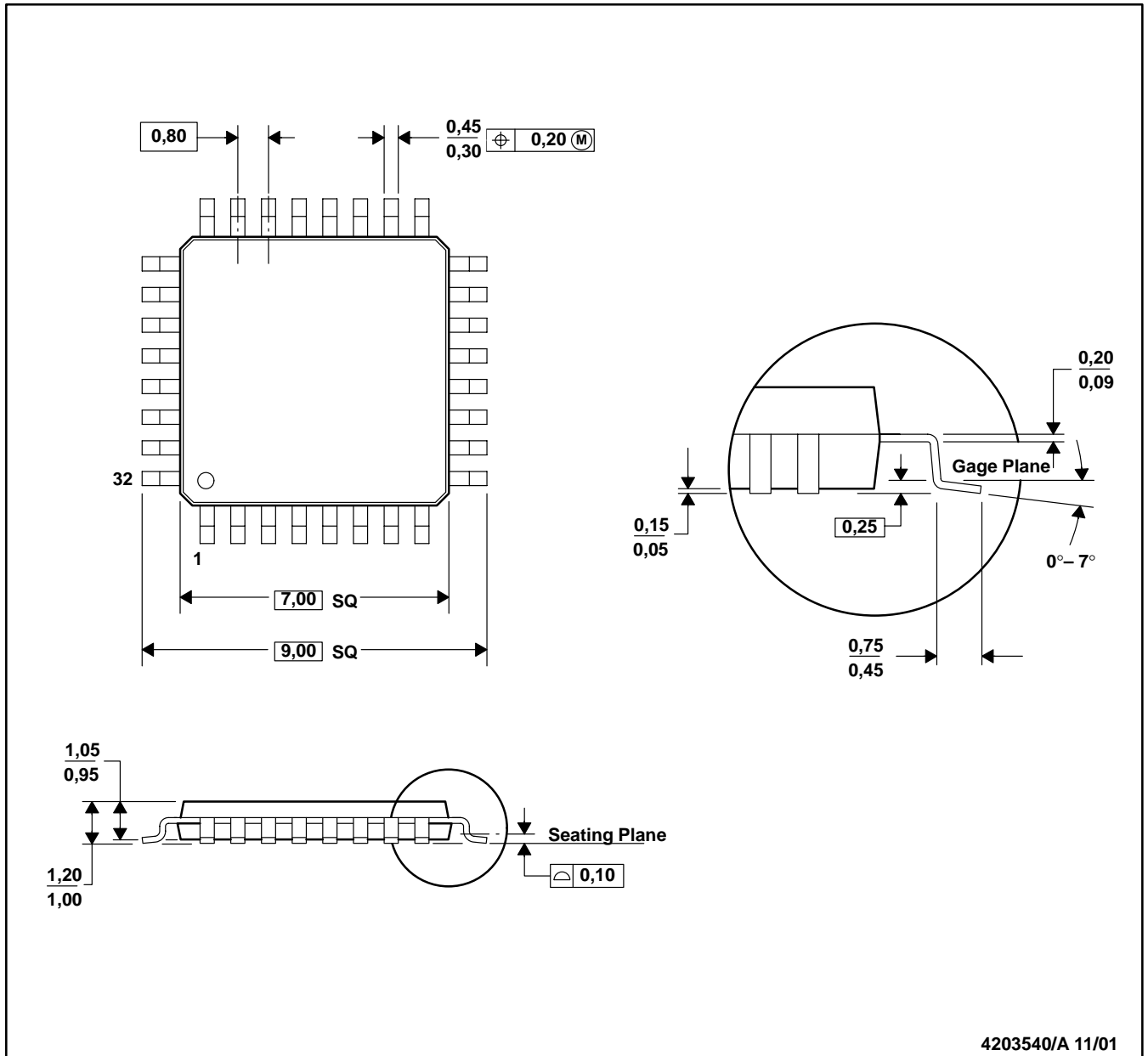

- NOTES: A. All linear dimensions are in millimeters.  
 B. This drawing is subject to change without notice.  
 C. Falls within JEDEC MS-026

## IMPORTANT NOTICE

Texas Instruments Incorporated and its subsidiaries (TI) reserve the right to make corrections, modifications, enhancements, improvements, and other changes to its products and services at any time and to discontinue any product or service without notice. Customers should obtain the latest relevant information before placing orders and should verify that such information is current and complete. All products are sold subject to TI's terms and conditions of sale supplied at the time of order acknowledgment.

TI warrants performance of its hardware products to the specifications applicable at the time of sale in accordance with TI's standard warranty. Testing and other quality control techniques are used to the extent TI deems necessary to support this warranty. Except where mandated by government requirements, testing of all parameters of each product is not necessarily performed.

TI assumes no liability for applications assistance or customer product design. Customers are responsible for their products and applications using TI components. To minimize the risks associated with customer products and applications, customers should provide adequate design and operating safeguards.

TI does not warrant or represent that any license, either express or implied, is granted under any TI patent right, copyright, mask work right, or other TI intellectual property right relating to any combination, machine, or process in which TI products or services are used. Information published by TI regarding third-party products or services does not constitute a license from TI to use such products or services or a warranty or endorsement thereof. Use of such information may require a license from a third party under the patents or other intellectual property of the third party, or a license from TI under the patents or other intellectual property of TI.

Reproduction of TI information in TI data books or data sheets is permissible only if reproduction is without alteration and is accompanied by all associated warranties, conditions, limitations, and notices. Reproduction of this information with alteration is an unfair and deceptive business practice. TI is not responsible or liable for such altered documentation. Information of third parties may be subject to additional restrictions.

Resale of TI products or services with statements different from or beyond the parameters stated by TI for that product or service voids all express and any implied warranties for the associated TI product or service and is an unfair and deceptive business practice. TI is not responsible or liable for any such statements.

TI products are not authorized for use in safety-critical applications (such as life support) where a failure of the TI product would reasonably be expected to cause severe personal injury or death, unless officers of the parties have executed an agreement specifically governing such use. Buyers represent that they have all necessary expertise in the safety and regulatory ramifications of their applications, and acknowledge and agree that they are solely responsible for all legal, regulatory and safety-related requirements concerning their products and any use of TI products in such safety-critical applications, notwithstanding any applications-related information or support that may be provided by TI. Further, Buyers must fully indemnify TI and its representatives against any damages arising out of the use of TI products in such safety-critical applications.

TI products are neither designed nor intended for use in military/aerospace applications or environments unless the TI products are specifically designated by TI as military-grade or "enhanced plastic." Only products designated by TI as military-grade meet military specifications. Buyers acknowledge and agree that any such use of TI products which TI has not designated as military-grade is solely at the Buyer's risk, and that they are solely responsible for compliance with all legal and regulatory requirements in connection with such use.

TI products are neither designed nor intended for use in automotive applications or environments unless the specific TI products are designated by TI as compliant with ISO/TS 16949 requirements. Buyers acknowledge and agree that, if they use any non-designated products in automotive applications, TI will not be responsible for any failure to meet such requirements.

Following are URLs where you can obtain information on other Texas Instruments products and application solutions:

### Products

Amplifiers	<a href="http://amplifier.ti.com">amplifier.ti.com</a>
Data Converters	<a href="http://dataconverter.ti.com">dataconverter.ti.com</a>
DSP	<a href="http://dsp.ti.com">dsp.ti.com</a>
Clocks and Timers	<a href="http://www.ti.com/clocks">www.ti.com/clocks</a>
Interface	<a href="http://interface.ti.com">interface.ti.com</a>
Logic	<a href="http://logic.ti.com">logic.ti.com</a>
Power Mgmt	<a href="http://power.ti.com">power.ti.com</a>
Microcontrollers	<a href="http://microcontroller.ti.com">microcontroller.ti.com</a>
RFID	<a href="http://www.ti-rfid.com">www.ti-rfid.com</a>
RF/IF and ZigBee® Solutions	<a href="http://www.ti.com/lprf">www.ti.com/lprf</a>

### Applications

Audio	<a href="http://www.ti.com/audio">www.ti.com/audio</a>
Automotive	<a href="http://www.ti.com/automotive">www.ti.com/automotive</a>
Broadband	<a href="http://www.ti.com/broadband">www.ti.com/broadband</a>
Digital Control	<a href="http://www.ti.com/digitalcontrol">www.ti.com/digitalcontrol</a>
Medical	<a href="http://www.ti.com/medical">www.ti.com/medical</a>
Military	<a href="http://www.ti.com/military">www.ti.com/military</a>
Optical Networking	<a href="http://www.ti.com/opticalnetwork">www.ti.com/opticalnetwork</a>
Security	<a href="http://www.ti.com/security">www.ti.com/security</a>
Telephony	<a href="http://www.ti.com/telephony">www.ti.com/telephony</a>
Video & Imaging	<a href="http://www.ti.com/video">www.ti.com/video</a>
Wireless	<a href="http://www.ti.com/wireless">www.ti.com/wireless</a>

Mailing Address: Texas Instruments, Post Office Box 655303, Dallas, Texas 75265  
Copyright © 2008, Texas Instruments Incorporated

## Looking for pricing, stock, or lifecycle information?

Click below to explore more details on WIN SOURCE:

 [View PCM1850APJTR](#) on WIN SOURCE

 [Texas Instruments](#) Information

## Optimize Your Supply Chain with WIN SOURCE Solutions

-  Global Sourcing Solution
-  Obsolete Management
-  Cost Control Management
-  Shortage Management
-  Alternative Solution
-  Excess Inventory Management