



THE DATASHEET OF
LM185H-2.5/883



Micropower Voltage Reference Diode

Check for Samples: [LM185-2.5QML](#)

FEATURES

- **Operating Current of 20 μ A to 20 mA**
- **0.6 Ω Dynamic Impedance (A grade)**
- **Low Temperature Coefficient**
- **Low Voltage Reference—2.5V**

DESCRIPTION

The LM185-2.5 are micropower 2-terminal band-gap voltage regulator diodes. Operating over a 20 μ A to 20 mA current range, they feature exceptionally low dynamic impedance and good temperature stability. On-chip trimming is used to provide tight voltage tolerance. Since the LM185-2.5 band-gap reference uses only transistors and resistors, low noise and good long term stability result.

Careful design of the LM185-2.5 has made the device exceptionally tolerant of capacitive loading, making it easy to use in almost any reference application. The wide dynamic operating range allows its use with widely varying supplies with excellent regulation.

The extremely low power drain of the LM185-2.5 makes it useful for micropower circuitry. This voltage reference can be used to make portable meters, regulators or general purpose analog circuitry with battery life approaching shelf life. Further, the wide operating current allows it to replace older references with a tighter tolerance part. For applications requiring 1.2V see LM185-1.2.

Connection Diagram

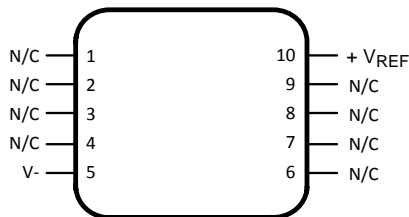

Figure 1. CLGA Package-Top View
See Package Number NAC

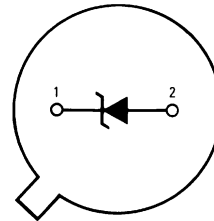

Figure 2. PFM Metal Can Package- Bottom View
See Package Number NDU



Please be aware that an important notice concerning availability, standard warranty, and use in critical applications of Texas Instruments semiconductor products and disclaimers thereto appears at the end of this data sheet.

All trademarks are the property of their respective owners.

Schematic Diagram

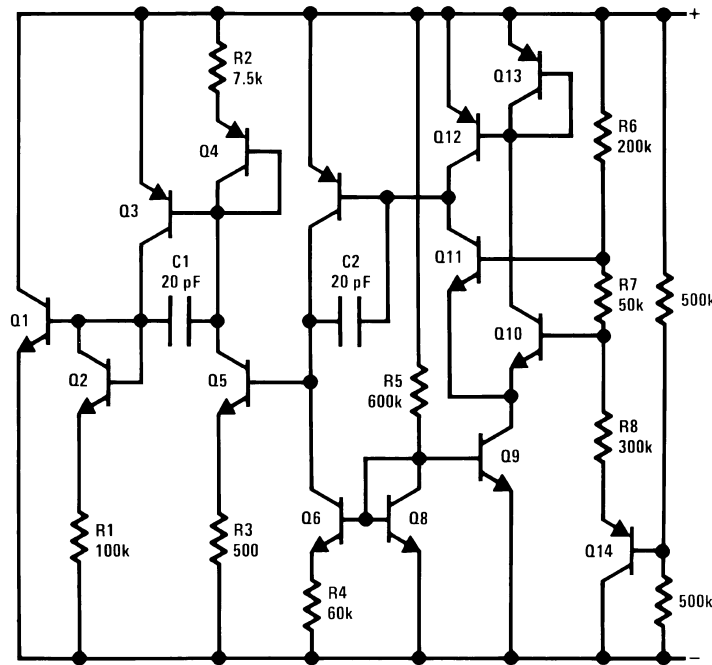

These devices have limited built-in ESD protection. The leads should be shorted together or the device placed in conductive foam during storage or handling to prevent electrostatic damage to the MOS gates.

Absolute Maximum Ratings⁽¹⁾

Reverse Current		30 mA	
Forward Current		10 mA	
Operating Temperature Range		-55°C ≤ T _A ≤ +125°C	
Storage Temperature		-55°C ≤ T _A ≤ +150°C	
Maximum Junction Temperature (T _{Jmax}) ⁽²⁾		150°C	
Lead Temperature (Soldering, 10 sec)	PFM Metal Can	300°C	
	Ceramic CLGA	260°C	
Thermal Resistance	θ _{JA}	PFM Metal Can (Still Air)	300°C/W
		PFM Metal Can (500LF / Min Air Flow)	139°C/W
		Ceramic CLGA (Still Air)	194°C/W
		Ceramic CLGA (500LF / Min Air Flow)	128°C/W
	θ _{JC}	PFM Metal Can	57°C/W
		Ceramic CLGA	23°C/W
Package Weight (Typical)	PFM Metal Can	TBD	
	Ceramic CLGA	210 mg	
ESD Tolerance ⁽³⁾		4000V	

- (1) Absolute Maximum Ratings indicate limits beyond which damage to the device may occur. Operating Ratings indicate conditions for which the device is functional, but do not ensure specific performance limits. For ensured specifications and test conditions, see the Electrical Characteristics. The ensured specifications apply only for the test conditions listed. Some performance characteristics may degrade when the device is not operated under the listed test conditions.
- (2) The maximum power dissipation must be derated at elevated temperatures and is dictated by T_{Jmax} (maximum junction temperature), θ_{JA} (package junction to ambient thermal resistance), and T_A (ambient temperature). The maximum allowable power dissipation at any temperature is P_{Dmax} = (T_{Jmax} - T_A)/θ_{JA} or the number given in the Absolute Maximum Ratings, whichever is lower.
- (3) Human body model, 1.5 kΩ in series with 100 pF

Table 1. Quality Conformance Inspection⁽¹⁾

Subgroup	Description	Temp °C
1	Static tests at	25
2	Static tests at	125
3	Static tests at	-55
4	Dynamic tests at	25
5	Dynamic tests at	125
6	Dynamic tests at	-55
7	Functional tests at	25
8A	Functional tests at	125
8B	Functional tests at	-55
9	Switching tests at	25
10	Switching tests at	125
11	Switching tests at	-55
12	Settling time at	25
13	Settling time at	125
14	Settling time at	-55

(1) Mil-Std-883, Method 5005 - Group A

LM185–2.5 Electrical Characteristics DC Parameters

Symbol	Parameter	Conditions	Notes	Min	Max	Units	Sub-groups
V_{Ref}	Reverse Breakdown Voltage	$I_R = 20\mu A$		2.462	2.538	V	1
		$I_R = 30\mu A$		2.425	2.575	V	2, 3
		$I_R = 1mA$		2.462	2.538	V	1
				2.425	2.575	V	2, 3
		$I_R = 20mA$		2.462	2.538	V	1
	2.425		2.575	V	2, 3		
$\Delta V_{Ref} / \Delta I_R$	Reverse Breakdown Voltage Change with Current	$20\mu A \leq I_R \leq 1mA$		-1.0	1.0	mV	1
		$30\mu A \leq I_R \leq 1mA$		-1.5	1.5	mV	2, 3
		$1mA \leq I_R \leq 20mA$		-10.0	10.0	mV	1
				-20.0	20.0	mV	2, 3
V_F	Forward Bias Voltage	$I_F = 2mA$		-1.0	-0.4	V	1

LM185–2.5 Electrical Characteristics DC Drift Parameters

Delta calculations performed on QMLV devices at group B , subgroup 5, unless otherwise specified on IPI.

Symbol	Parameter	Conditions	Notes	Min	Max	Units	Sub-groups
V_{Ref}	Reverse Breakdown Voltage	$I_R = 20\mu A$		-10	10	mV	1
		$I_R = 20mA$		-10	10	mV	1

LM185BY–2.5 Electrical Characteristics DC Parameters

Symbol	Parameter	Conditions	Notes	Min	Max	Units	Sub-groups
V_{Ref}	Reverse Breakdown Voltage	$I_R = 20\mu A$		2.462	2.538	V	1
		$I_R = 30\mu A$		2.425	2.575	V	2, 3
		$I_R = 1mA$		2.462	2.538	V	1
				2.425	2.575	V	2, 3
		$I_R = 20mA$		2.462	2.538	V	1
				2.425	2.575	V	2, 3
$\Delta V_{Ref} / \Delta I_R$	Reverse Breakdown Voltage Change with Current	$20\mu A \leq I_R \leq 1mA$		-1.0	1.0	mV	1
		$30\mu A \leq I_R \leq 1mA$		-1.5	1.5	mV	2, 3
		$1mA \leq I_R \leq 20mA$		-10.0	10.0	mV	1
				-20.0	20.0	mV	2, 3
V_F	Forward Bias Voltage	$I_F = 2mA$		-1.0	-0.4	V	1
T_C	Temperature Coefficient		(1)		50	PPM/°C	2, 3

(1) The average temperature coefficient is defined as the maximum deviation of reference voltage, at all measured temperatures between the operating T_{Min} & T_{Max} , divided by $(T_{Max} - T_{Min})$. The measured temperatures ($T_{Measured}$) are $-55^\circ C$, $25^\circ C$, & $125^\circ C$ or $\Delta V_{Ref} / (T_{Max} - T_{Min})$

LM185BY–2.5 Electrical Characteristics DC Drift Parameters

Delta calculations performed on QMLV devices at group B , subgroup 5, unless otherwise specified on IPI.

Symbol	Parameter	Conditions	Notes	Min	Max	Units	Sub-groups
$V_{Ref 1}$	Reverse Breakdown Voltage	$I_R = 20\mu A$		-10	10	mV	1
$V_{Ref 2}$	Reverse Breakdown Voltage	$I_R = 20mA$		-10	10	mV	1

Typical Performance Characteristics

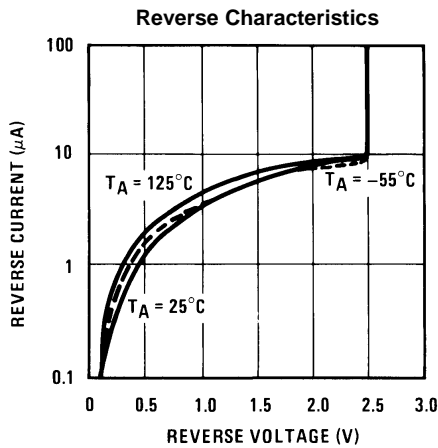

Figure 3.

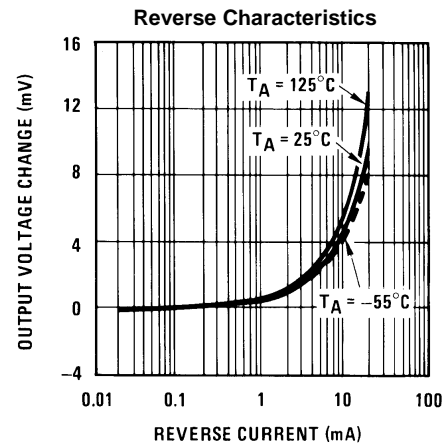

Figure 4.

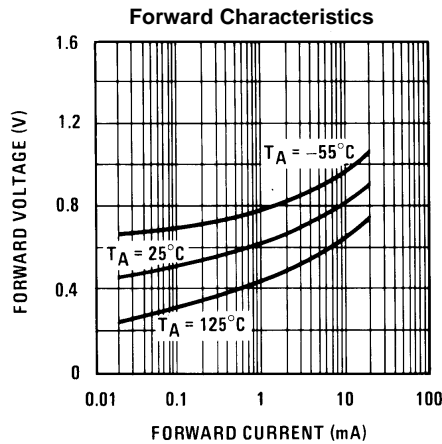

Figure 5.

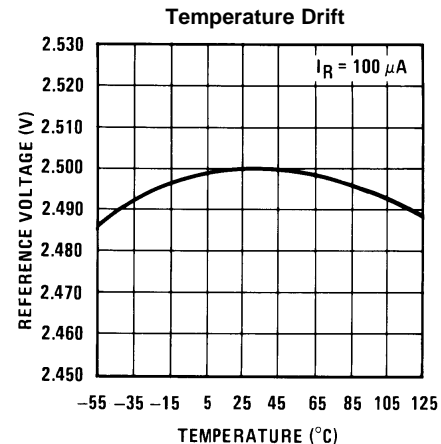

Figure 6.

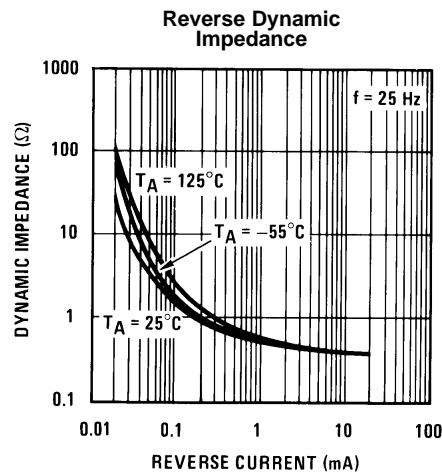

Figure 7.

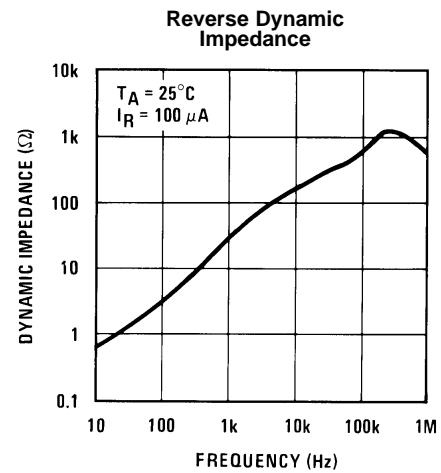

Figure 8.

Typical Performance Characteristics (continued)

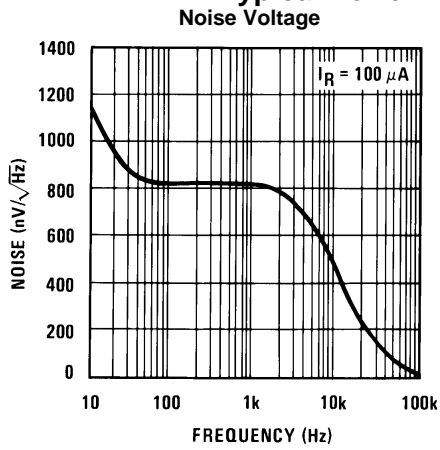

Figure 9.

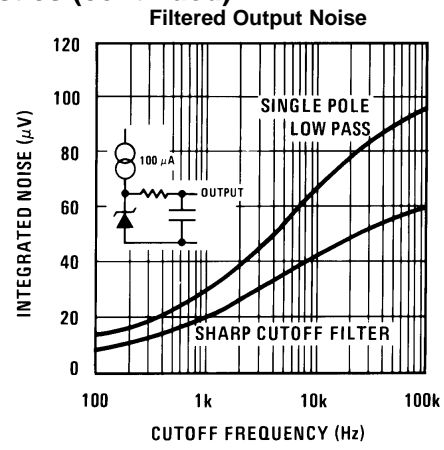

Figure 10.

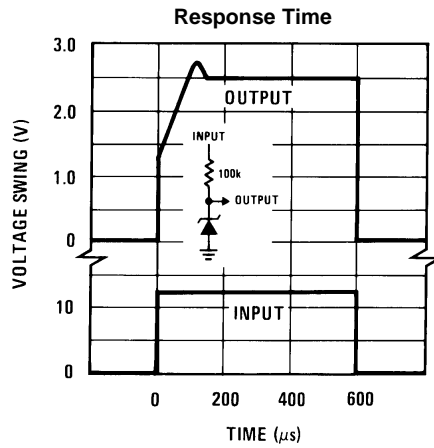

Figure 11.

APPLICATIONS

Figure 12. Wide Input Range Reference

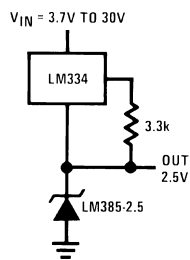

Figure 13. Micropower Reference from 9V Battery

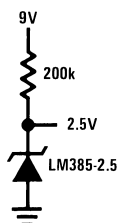
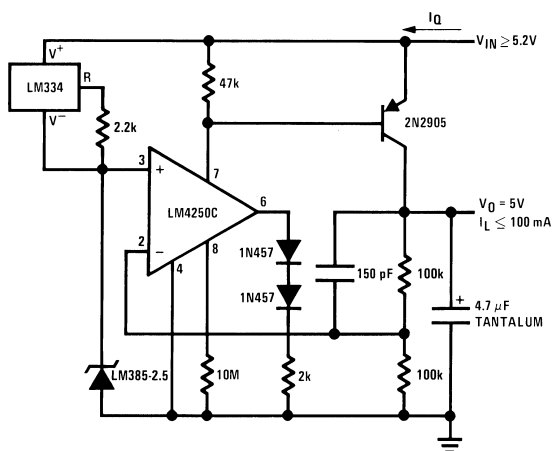
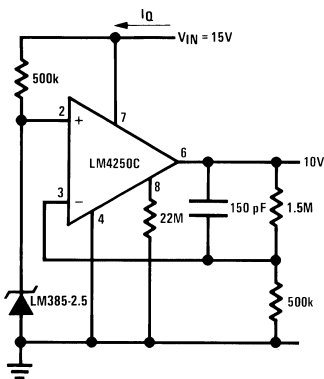

Figure 14. Micropower 5V Reference



$I_Q \approx 40 \mu A$

Figure 15. Micropower 10V Reference



$I_Q \approx 30 \mu A$ standby current

Precision 1 μA to 1 mA Current Sources

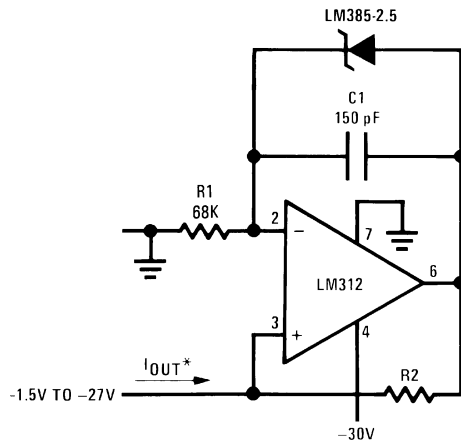

$$I_{OUT} = \frac{2.5V}{R_2}$$

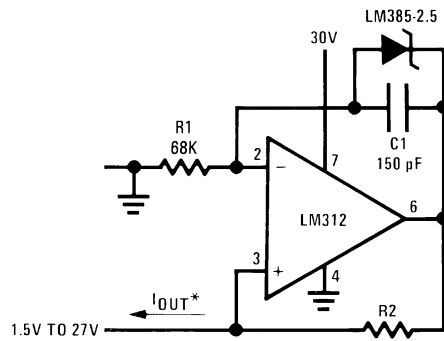

METER THERMOMETERS

Figure 16. 0°C–100°C Thermometer

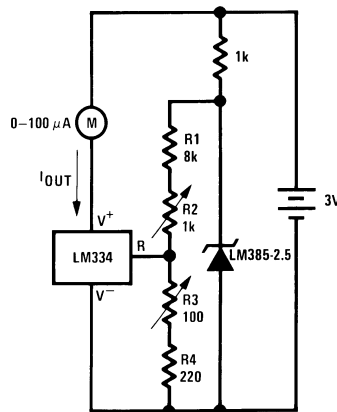

Calibration

1. Short LM385-2.5, adjust R3 for I_{OUT}= temp at 1μA/°K
2. Remove short, adjust R2 for correct reading in centigrade

Figure 17. 0°F–50°F Thermometer

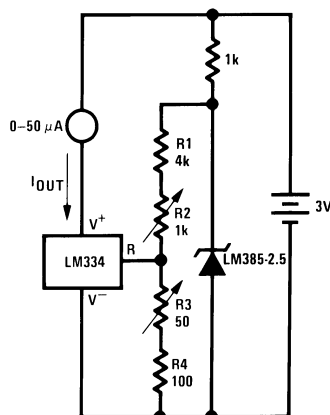

Calibration

1. Short LM385-2.5, adjust R3 for $I_{OUT} = \text{temp}$ at $1.8 \mu\text{A}/^\circ\text{K}$
2. Remove short, adjust R2 for correct reading in $^\circ\text{F}$

Figure 18. Improving Regulation of Adjustable Regulators

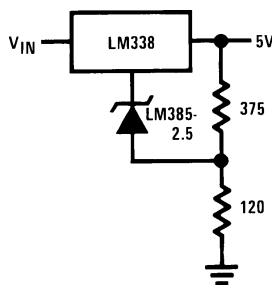
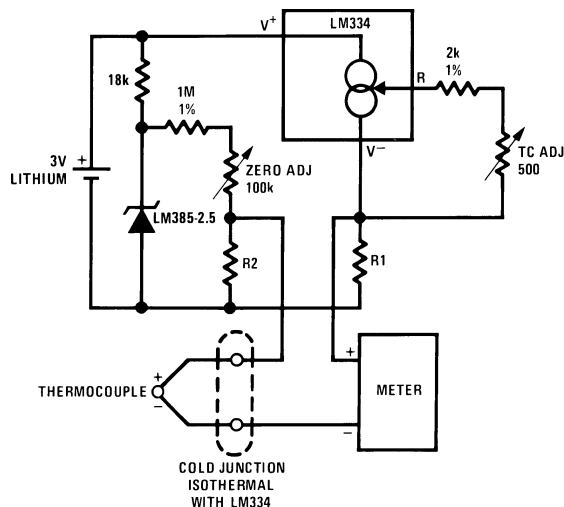

Figure 19. Micropower Thermocouple Cold Junction Compensator



Adjustment Procedure

1. Adjust TC ADJ pot until voltage across R1 equals Kelvin temperature multiplied by the thermocouple Seebeck coefficient.
2. Adjust zero ADJ pot until voltage across R2 equals the thermocouple Seebeck coefficient multiplied by 273.2.

Thermocouple Type	Seebeck Co-efficient ($\mu\text{V}/^\circ\text{C}$)	R1 (Ω)	R2 (Ω)	Voltage Across R1 @ 25°C (mV)	Voltage Across R2 (mV)
J	52.3	523	1.24k	15.60	14.32
T	42.8	432	1k	12.77	11.78
K	40.8	412	953 Ω	12.17	11.17
S	6.4	63.4	150 Ω	1.908	1.766

REVISION HISTORY SECTION

Released	Revision	Section	Originator	Changes
11/08/05	A	New Release, Corporate format	L. Lytle	2 MDS data sheets converted into one Corp. data sheet format. MNLM185-2.5-X Rev 2A2 and MNLM185-2.5BY-X Rev 1B1 will be archived.
03/20/13	A	All		Changed layout of National Data Sheet to TI format.

PACKAGING INFORMATION

Orderable Device	Status (1)	Package Type	Package Drawing	Pins	Package Qty	Eco Plan (2)	Lead finish/ Ball material (6)	MSL Peak Temp (3)	Op Temp (°C)	Device Marking (4/5)	Samples
5962-8759402XA	ACTIVE	TO	NDU	2	20	Non-RoHS & Non-Green	Call TI	Call TI	-55 to 125	8759402XA Q	Samples
5962-8759402YA	ACTIVE	CFP	NAC	10	54	Non-RoHS & Green	Call TI	Level-1-NA-UNLIM	-55 to 125	LM185WG-2.5/883 Q 5962-87594 02YA ACO 02YA >T	Samples
5962-8759406VXA	ACTIVE	TO	NDU	2	20	Non-RoHS & Non-Green	Call TI	Call TI	-55 to 125	8759406VXA Q	Samples
LM185-2.5 MD8	ACTIVE	DIESALE	Y	0	100	RoHS & Green	Call TI	Level-1-NA-UNLIM	-55 to 125		Samples
LM185BYH2.5-QV	ACTIVE	TO	NDU	2	20	Non-RoHS & Green	Call TI	Level-1-NA-UNLIM	-55 to 125	8759406VXA Q	Samples
LM185BYH2.5/883	ACTIVE	TO	NDU	2	20	Non-RoHS & Non-Green	Call TI	Call TI	-55 to 125	LM185BY2.5 Q	Samples
LM185H-2.5-SMD	ACTIVE	TO	NDU	2	20	Non-RoHS & Non-Green	Call TI	Call TI	-55 to 125	8759402XA Q	Samples
LM185H-2.5/883	ACTIVE	TO	NDU	2	20	Non-RoHS & Non-Green	Call TI	Call TI	-55 to 125	LM185-2.5 Q	Samples
LM185WG-2.5/883	ACTIVE	CFP	NAC	10	54	Non-RoHS & Green	Call TI	Level-1-NA-UNLIM	-55 to 125	LM185WG-2.5/883 Q 5962-87594 02YA ACO 02YA >T	Samples

(1) The marketing status values are defined as follows:

ACTIVE: Product device recommended for new designs.

LIFEBUY: TI has announced that the device will be discontinued, and a lifetime-buy period is in effect.

NRND: Not recommended for new designs. Device is in production to support existing customers, but TI does not recommend using this part in a new design.

PREVIEW: Device has been announced but is not in production. Samples may or may not be available.

OBSELETE: TI has discontinued the production of the device.

(2) **RoHS:** TI defines "RoHS" to mean semiconductor products that are compliant with the current EU RoHS requirements for all 10 RoHS substances, including the requirement that RoHS substance do not exceed 0.1% by weight in homogeneous materials. Where designed to be soldered at high temperatures, "RoHS" products are suitable for use in specified lead-free processes. TI may reference these types of products as "Pb-Free".

RoHS Exempt: TI defines "RoHS Exempt" to mean products that contain lead but are compliant with EU RoHS pursuant to a specific EU RoHS exemption.

Green: TI defines "Green" to mean the content of Chlorine (Cl) and Bromine (Br) based flame retardants meet JS709B low halogen requirements of ≤ 1000 ppm threshold. Antimony trioxide based flame retardants must also meet the ≤ 1000 ppm threshold requirement.

(3) MSL, Peak Temp. - The Moisture Sensitivity Level rating according to the JEDEC industry standard classifications, and peak solder temperature.

(4) There may be additional marking, which relates to the logo, the lot trace code information, or the environmental category on the device.

(5) Multiple Device Markings will be inside parentheses. Only one Device Marking contained in parentheses and separated by a "~" will appear on a device. If a line is indented then it is a continuation of the previous line and the two combined represent the entire Device Marking for that device.

(6) Lead finish/Ball material - Orderable Devices may have multiple material finish options. Finish options are separated by a vertical ruled line. Lead finish/Ball material values may wrap to two lines if the finish value exceeds the maximum column width.

Important Information and Disclaimer: The information provided on this page represents TI's knowledge and belief as of the date that it is provided. TI bases its knowledge and belief on information provided by third parties, and makes no representation or warranty as to the accuracy of such information. Efforts are underway to better integrate information from third parties. TI has taken and continues to take reasonable steps to provide representative and accurate information but may not have conducted destructive testing or chemical analysis on incoming materials and chemicals. TI and TI suppliers consider certain information to be proprietary, and thus CAS numbers and other limited information may not be available for release.

In no event shall TI's liability arising out of such information exceed the total purchase price of the TI part(s) at issue in this document sold by TI to Customer on an annual basis.

OTHER QUALIFIED VERSIONS OF LM185-2.5QML, LM185-2.5QML-SP :

- Military : [LM185-2.5QML](#)
- Space : [LM185-2.5QML-SP](#)

NOTE: Qualified Version Definitions:

- Military - QML certified for Military and Defense Applications
- Space - Radiation tolerant, ceramic packaging and qualified for use in Space-based application

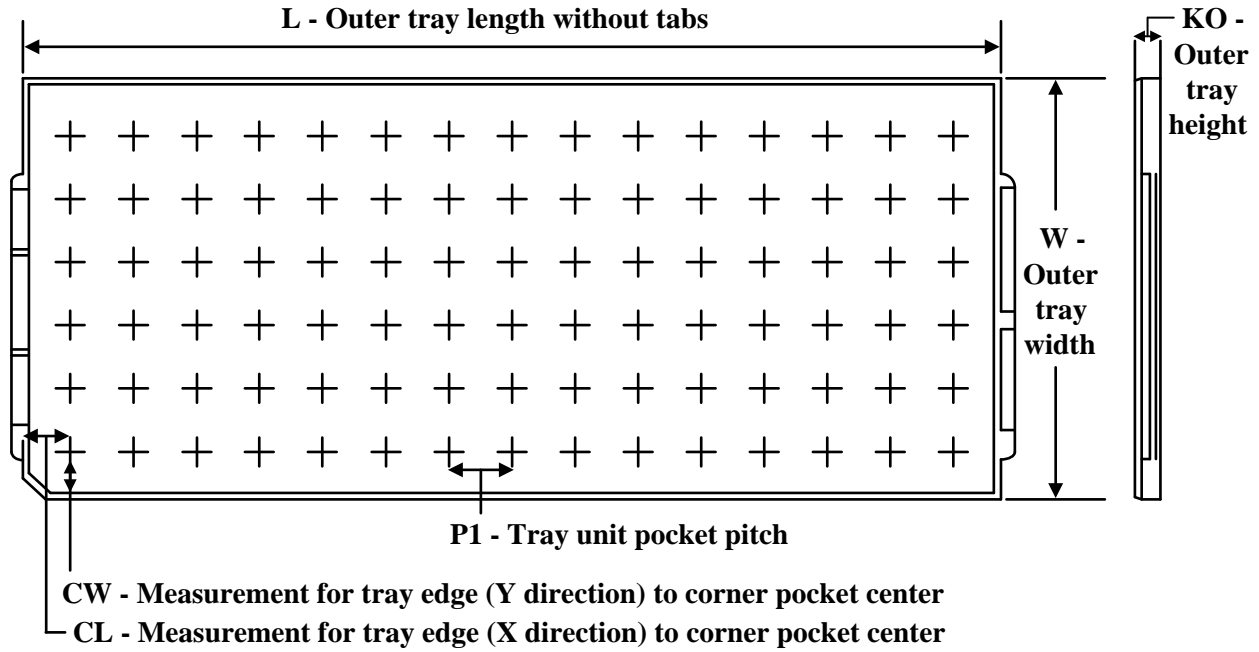
TRAY

Chamfer on Tray corner indicates Pin 1 orientation of packed units.

*All dimensions are nominal

Device	Package Name	Package Type	Pins	SPQ	Unit array matrix	Max temperature (°C)	L (mm)	W (mm)	K0 (µm)	P1 (mm)	CL (mm)	CW (mm)
5962-8759402XA	NDU	TO-CAN	2	20	2 X 10	150	126.49	61.98	10922	11.43	11.81	19.2
5962-8759402YA	NAC	CFP	10	54	6 X 9	100	101.6	101.6	8001	2.78	16.08	16.08
5962-8759406VXA	NDU	TO-CAN	2	20	2 X 10	150	126.49	61.98	10922	11.43	11.81	19.2
LM185BYH2.5-QV	NDU	TO-CAN	2	20	2 X 10	150	126.49	61.98	10922	11.43	11.81	19.2
LM185BYH2.5/883	NDU	TO-CAN	2	20	2 X 10	150	126.49	61.98	10922	11.43	11.81	19.2
LM185H-2.5-SMD	NDU	TO-CAN	2	20	2 X 10	150	126.49	61.98	10922	11.43	11.81	19.2
LM185H-2.5/883	NDU	TO-CAN	2	20	2 X 10	150	126.49	61.98	10922	11.43	11.81	19.2
LM185WG-2.5/883	NAC	CFP	10	54	6 X 9	100	101.6	101.6	8001	2.78	16.08	16.08

NDU0002A

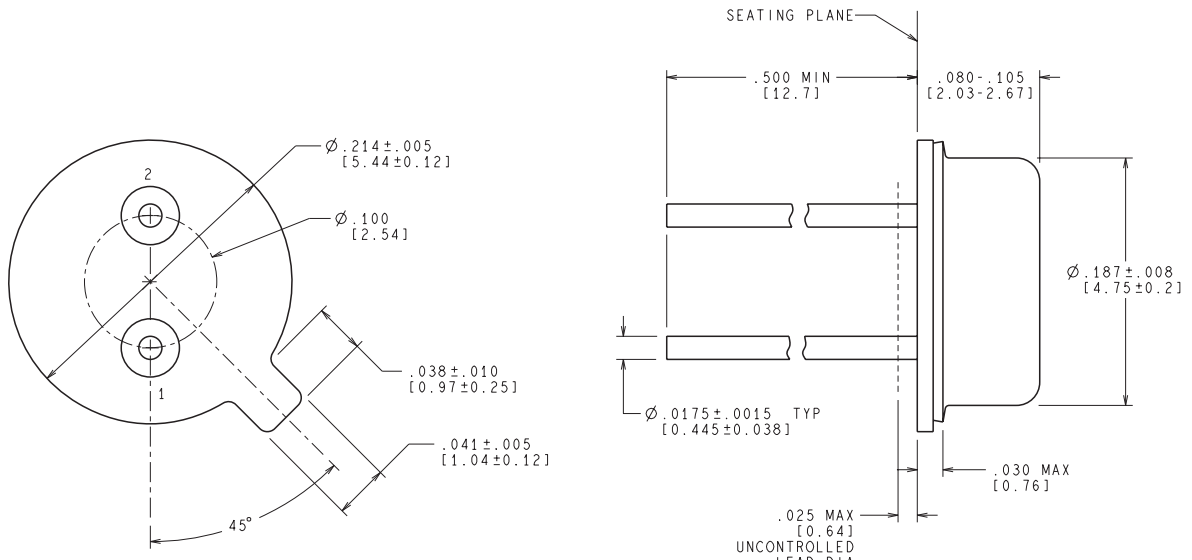

CONTROLLING DIMENSION IS INCH
VALUES IN [] ARE MILLIMETERS

H02A (Rev F)



PACKAGE OUTLINE

NAC0010A

CFP - 2.33mm max height

CERAMIC FLATPACK

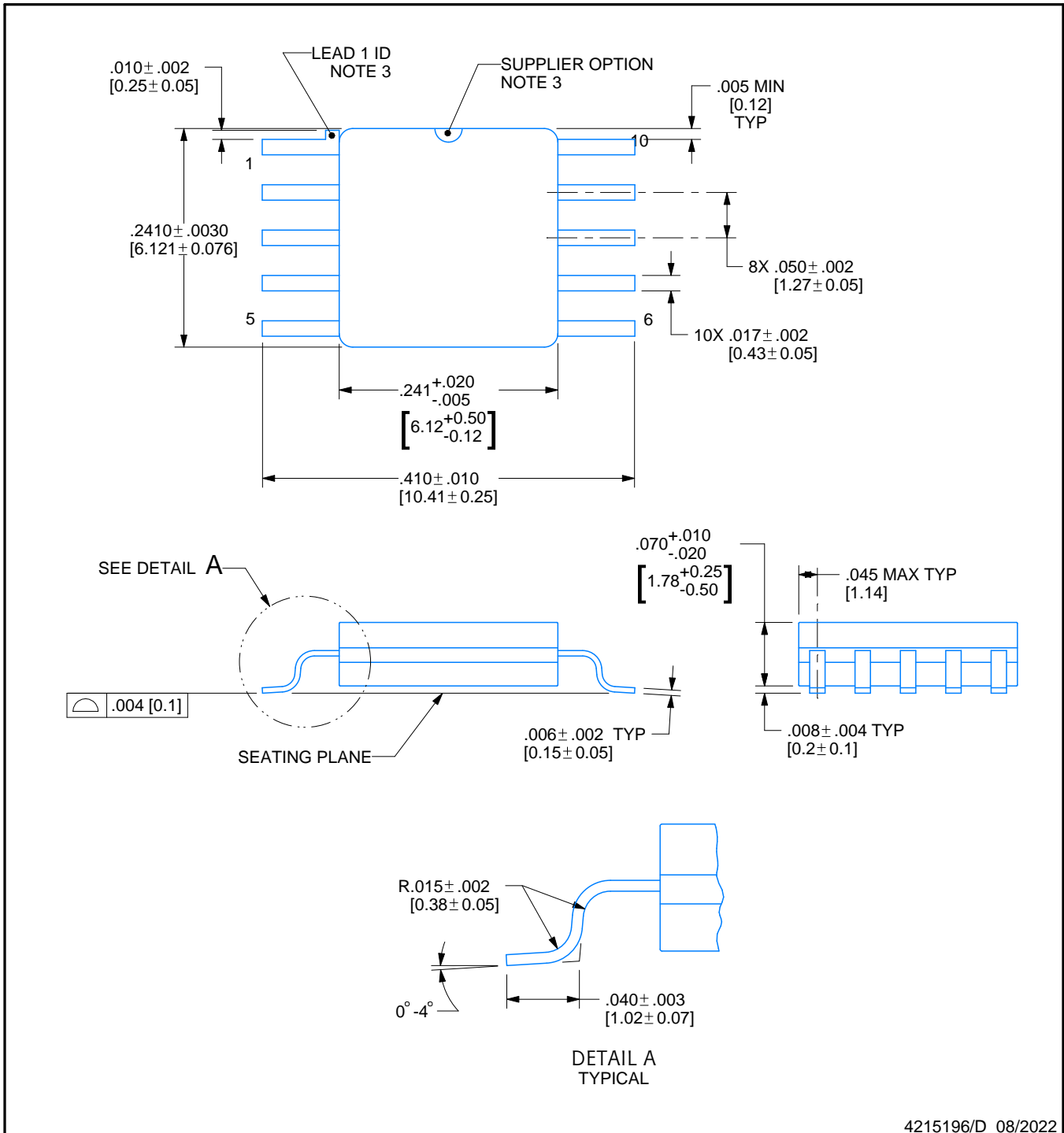

4215196/D 08/2022

NOTES:

1. All controlling linear dimensions are in inches. Dimensions in brackets are in millimeters. Any dimension in brackets or parenthesis are for reference only. Dimensioning and tolerancing per ASME Y14.5M.
2. For solder thickness and composition, see the "Lead Finish Composition/Thickness" link in the packaging section of the Texas Instruments website
3. Lead 1 identification shall be:
 - a) A notch or other mark within this area
 - b) A tab on lead 1, either side
4. No JEDEC registration as of December 2021

EXAMPLE BOARD LAYOUT

NAC0010A

CFP - 2.33mm max height

CERAMIC FLATPACK

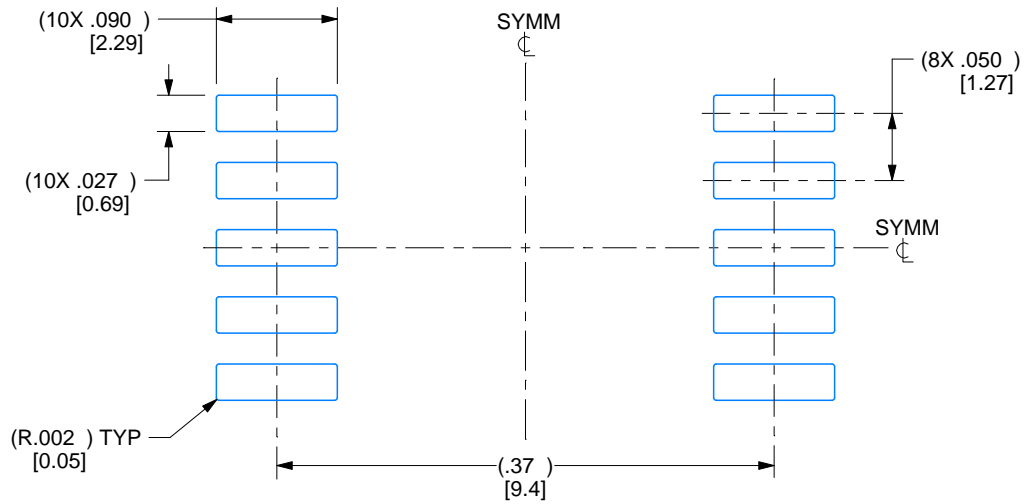

LAND PATTERN EXAMPLE
EXPOSED METAL SHOWN
SCALE: 7X

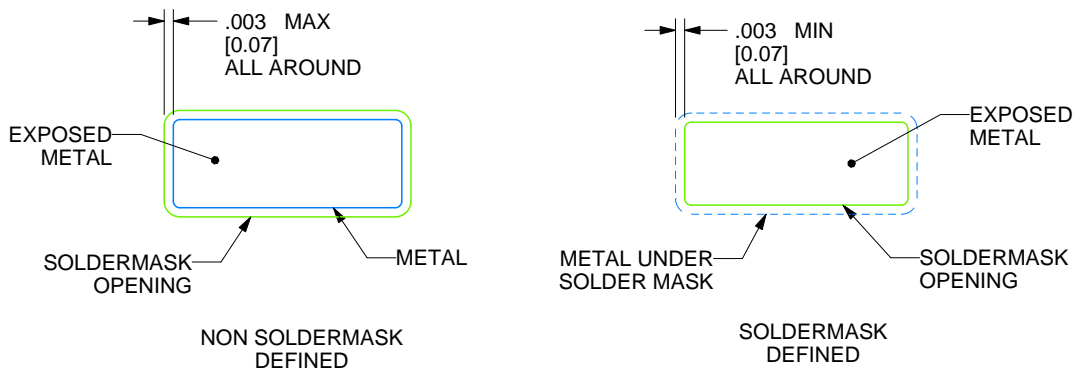

4215196/D 08/2022

REVISIONS

REV	DESCRIPTION	E.C.N.	DATE	BY/APP'D
A	RELEASE TO DOCUMENT CONTROL	2197877	12/30/2021	DAVID CHIN / ANIS FAUZI
B	NO CHANGE TO DRAWING; REVISION FOR YODA RELEASE;	2198820	02/14/2022	K. SINCERBOX
C	CHANGE PIN 1 ID LOCATION ON PIN	2198845	02/18/2022	D. CHIN / K. SINCERBOX
D	.2410± .0030 WAS .2700 +.0012/- .0002;	2200915	08/08/2022	D. CHIN / K. SINCERBOX

IMPORTANT NOTICE AND DISCLAIMER

TI PROVIDES TECHNICAL AND RELIABILITY DATA (INCLUDING DATA SHEETS), DESIGN RESOURCES (INCLUDING REFERENCE DESIGNS), APPLICATION OR OTHER DESIGN ADVICE, WEB TOOLS, SAFETY INFORMATION, AND OTHER RESOURCES "AS IS" AND WITH ALL FAULTS, AND DISCLAIMS ALL WARRANTIES, EXPRESS AND IMPLIED, INCLUDING WITHOUT LIMITATION ANY IMPLIED WARRANTIES OF MERCHANTABILITY, FITNESS FOR A PARTICULAR PURPOSE OR NON-INFRINGEMENT OF THIRD PARTY INTELLECTUAL PROPERTY RIGHTS.

These resources are intended for skilled developers designing with TI products. You are solely responsible for (1) selecting the appropriate TI products for your application, (2) designing, validating and testing your application, and (3) ensuring your application meets applicable standards, and any other safety, security, regulatory or other requirements.

These resources are subject to change without notice. TI grants you permission to use these resources only for development of an application that uses the TI products described in the resource. Other reproduction and display of these resources is prohibited. No license is granted to any other TI intellectual property right or to any third party intellectual property right. TI disclaims responsibility for, and you will fully indemnify TI and its representatives against, any claims, damages, costs, losses, and liabilities arising out of your use of these resources.

TI's products are provided subject to [TI's Terms of Sale](#) or other applicable terms available either on [ti.com](https://www.ti.com) or provided in conjunction with such TI products. TI's provision of these resources does not expand or otherwise alter TI's applicable warranties or warranty disclaimers for TI products.

TI objects to and rejects any additional or different terms you may have proposed.

Mailing Address: Texas Instruments, Post Office Box 655303, Dallas, Texas 75265
Copyright © 2024, Texas Instruments Incorporated

Looking for pricing, stock, or lifecycle information?

Click below to explore more details on WIN SOURCE:

 [View LM185H-2.5/883 on WIN SOURCE](#)

 [Texas Instruments](#) Information

Optimize Your Supply Chain with WIN SOURCE Solutions

-  Global Sourcing Solution
-  Obsolete Management
-  Cost Control Management
-  Shortage Management
-  Alternative Solution
-  Excess Inventory Management