

High-Performance 8-bit CMOS EPROM Microcontrollers with 10-bit A/D

Microcontroller Core Features:

- Only 58 single word instructions to learn
- All single cycle instructions (121 ns), except for program branches and table reads/writes which are two-cycle
- Operating speed:
 - DC - 33 MHz clock input
 - DC - 121 ns instruction cycle
- 8 x 8 Single-Cycle Hardware Multiplier
- Interrupt capability
- 16 level deep hardware stack
- Direct, indirect, and relative addressing modes
- Internal/external program memory execution, capable of addressing 64 K x 16 program memory space

Device	Memory	
	Program (x16)	Data (x8)
PIC17C752	8 K	678
PIC17C756A	16 K	902
PIC17C762	8 K	678
PIC17C766	16 K	902

Peripheral Features:

- Up to 66 I/O pins with individual direction control
- 10-bit, multi-channel Analog-to-Digital converter
- High current sink/source for direct LED drive
- Four capture input pins
 - Captures are 16-bit, max resolution 121 ns
- Three PWM outputs (resolution is 1 to 10-bits)
- TMR0: 16-bit timer/counter with 8-bit programmable prescaler
- TMR1: 8-bit timer/counter
- TMR2: 8-bit timer/counter
- TMR3: 16-bit timer/counter
- Two Universal Synchronous Asynchronous Receiver Transmitters (USART/SCI) with independent baud rate generators
- Synchronous Serial Port (SSP) with SPI™ and I²C™ modes (including I²C Master mode)

Pin Diagrams

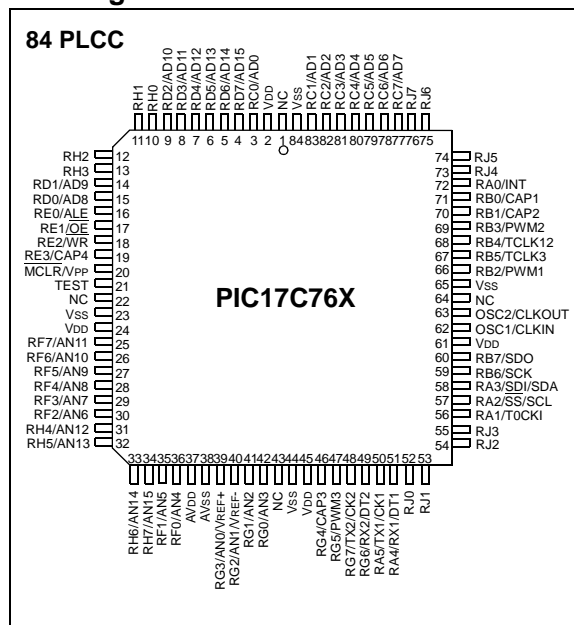

Special Microcontroller Features:

- Power-on Reset (POR), Power-up Timer (PWRT) and Oscillator Start-up Timer (OST)
- Watchdog Timer (WDT) with its own on-chip RC oscillator for reliable operation
- Brown-out Reset
- Code protection
- Power saving SLEEP mode
- Selectable oscillator options

CMOS Technology:

- Low power, high speed CMOS EPROM technology
- Fully static design
- Wide operating voltage range (3.0V to 5.5V)
- Commercial and Industrial temperature ranges
- Low power consumption
 - < 5 mA @ 5V, 4 MHz
 - 100 µA typical @ 4.5V, 32 kHz
 - < 1 µA typical standby current @ 5V

PIC17C7XX

Pin Diagrams cont.'d

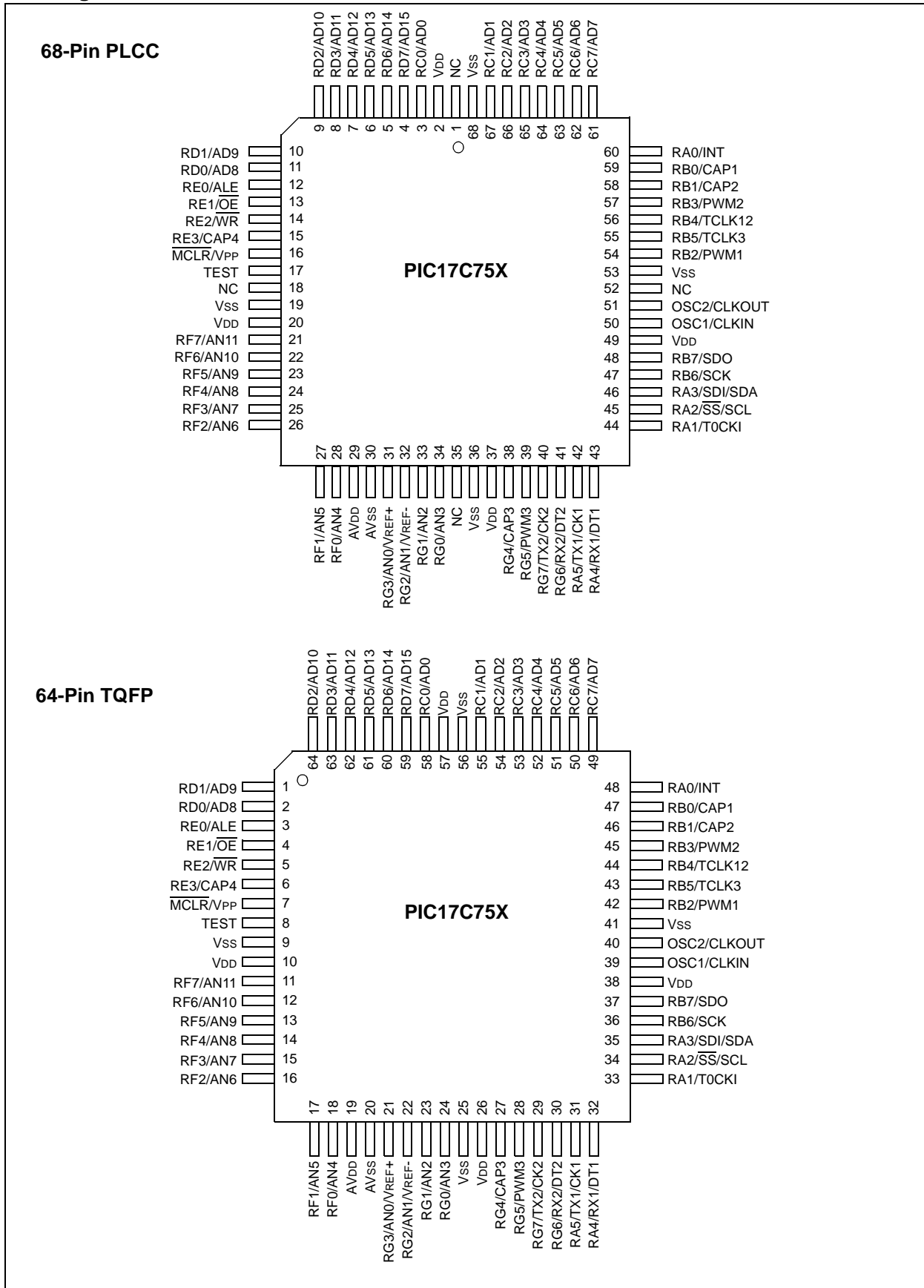

Pin Diagrams cont.'d

84-pin PLCC

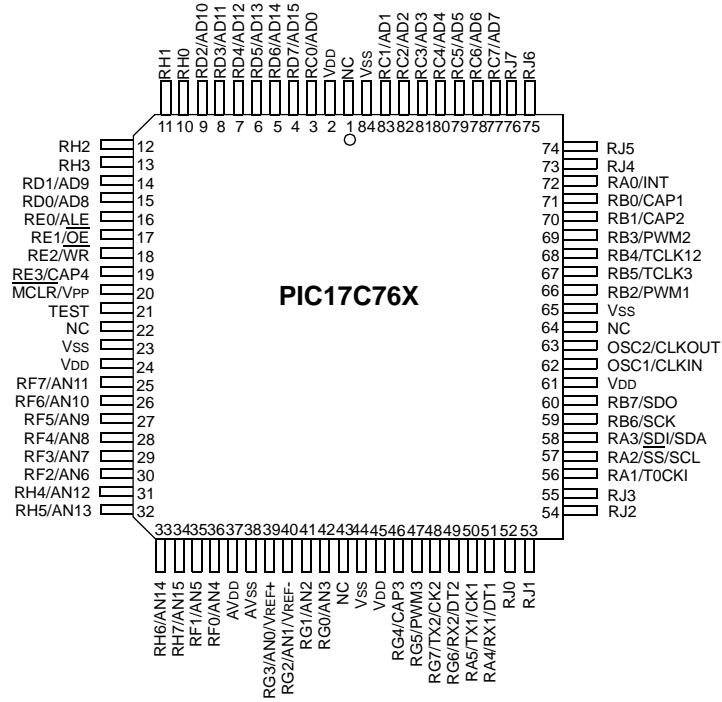

80-Pin TQFP

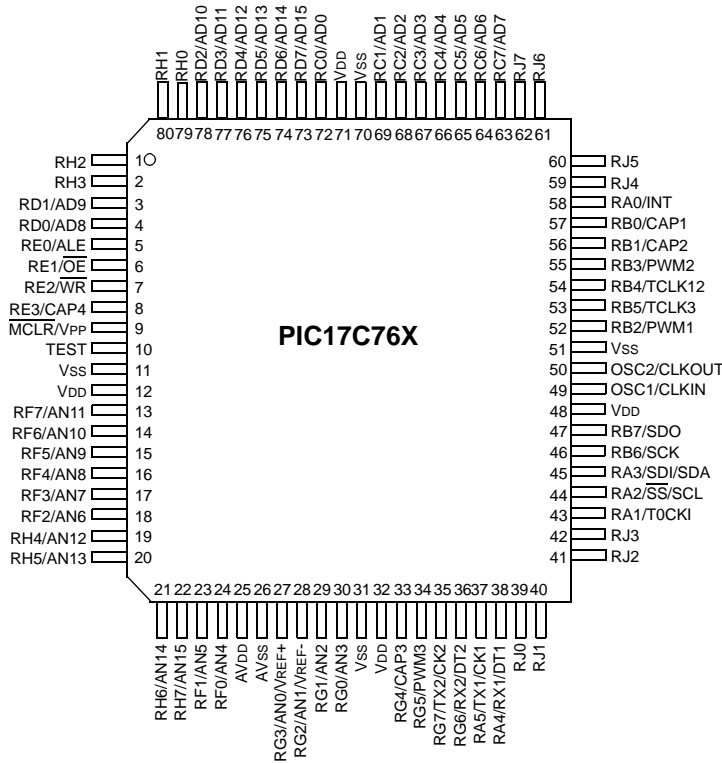

PIC17C7XX

Table of Contents

1.0	Overview	7
2.0	Device Varieties	9
3.0	Architectural Overview	11
4.0	On-chip Oscillator Circuit	17
5.0	Reset.....	23
6.0	Interrupts.....	33
7.0	Memory Organization.....	43
8.0	Table Reads and Table Writes	59
9.0	Hardware Multiplier	67
10.0	I/O Ports.....	71
11.0	Overview of Timer Resources.....	95
12.0	Timer0.....	97
13.0	Timer1, Timer2, Timer3, PWMs and Captures	101
14.0	Universal Synchronous Asynchronous Receiver Transmitter (USART) Modules.....	117
15.0	Master Synchronous Serial Port (MSSP) Module	133
16.0	Analog-to-Digital Converter (A/D) Module	179
17.0	Special Features of the CPU	191
18.0	Instruction Set Summary.....	197
19.0	Development Support	233
20.0	PIC17C7XX Electrical Characteristics	239
21.0	PIC17C7XX DC and AC Characteristics.....	267
22.0	Packaging Information	281
Appendix A:	Modifications	287
Appendix B:	Compatibility.....	287
Appendix C:	What's New	288
Appendix D:	What's Changed.....	288
Index		289
On-Line Support.....		299
Reader Response		300
Product Identification System.....		301

TO OUR VALUED CUSTOMERS

It is our intention to provide our valued customers with the best documentation possible to ensure successful use of your Microchip products. To this end, we will continue to improve our publications to better suit your needs. Our publications will be refined and enhanced as new volumes and updates are introduced.

If you have any questions or comments regarding this publication, please contact the Marketing Communications Department via E-mail at docerrors@mail.microchip.com or fax the **Reader Response Form** in the back of this data sheet to (480) 792-4150. We welcome your feedback.

Most Current Data Sheet

To obtain the most up-to-date version of this data sheet, please register at our Worldwide Web site at:

<http://www.microchip.com>

You can determine the version of a data sheet by examining its literature number found on the bottom outside corner of any page. The last character of the literature number is the version number, (e.g., DS30000A is version A of document DS30000).

Errata

An errata sheet, describing minor operational differences from the data sheet and recommended workarounds, may exist for current devices. As device/documentation issues become known to us, we will publish an errata sheet. The errata will specify the revision of silicon and revision of document to which it applies.

To determine if an errata sheet exists for a particular device, please check with one of the following:

- Microchip's Worldwide Web site; <http://www.microchip.com>
- Your local Microchip sales office (see last page)
- The Microchip Corporate Literature Center; U.S. FAX: (480) 792-7277

When contacting a sales office or the literature center, please specify which device, revision of silicon and data sheet (include literature number) you are using.

Customer Notification System

Register on our web site at www.microchip.com/cn to receive the most current information on all of our products.

PIC17C7XX

NOTES:

1.0 OVERVIEW

This data sheet covers the PIC17C7XX group of the PIC17CXXX family of microcontrollers. The following devices are discussed in this data sheet:

- PIC17C752
- PIC17C756A
- PIC17C762
- PIC17C766

The PIC17C7XX devices are 68/84-pin, EPROM based members of the versatile PIC17CXXX family of low cost, high performance, CMOS, fully static, 8-bit microcontrollers.

All PIC[®] microcontrollers employ an advanced RISC architecture. The PIC17CXXX has enhanced core features, 16-level deep stack, and multiple internal and external interrupt sources. The separate instruction and data buses of the Harvard architecture allow a 16-bit wide instruction word with a separate 8-bit wide data path. The two stage instruction pipeline allows all instructions to execute in a single cycle, except for program branches (which require two cycles). A total of 58 instructions (reduced instruction set) are available. Additionally, a large register set gives some of the architectural innovations used to achieve a very high performance. For mathematical intensive applications, all devices have a single cycle 8 x 8 Hardware Multiplier.

PIC17CXXX microcontrollers typically achieve a 2:1 code compression and a 4:1 speed improvement over other 8-bit microcontrollers in their class.

PIC17C7XX devices have up to 902 bytes of RAM and 66 I/O pins. In addition, the PIC17C7XX adds several peripheral features, useful in many high performance applications, including:

- Four timer/counters
- Four capture inputs
- Three PWM outputs
- Two independent Universal Synchronous Asynchronous Receiver Transmitters (USARTs)
- An A/D converter (multi-channel, 10-bit resolution)
- A Synchronous Serial Port (SPI and I²C w/ Master mode)

These special features reduce external components, thus reducing cost, enhancing system reliability and reducing power consumption.

There are four oscillator options, of which the single pin RC oscillator provides a low cost solution, the LF oscillator is for low frequency crystals and minimizes power consumption, XT is a standard crystal and the EC is for external clock input.

The SLEEP (power-down) mode offers additional power saving. Wake-up from SLEEP can occur through several external and internal interrupts and device RESETS.

A highly reliable Watchdog Timer with its own on-chip RC oscillator provides protection against software malfunction.

There are four configuration options for the device operational mode:

- Microprocessor
- Microcontroller
- Extended microcontroller
- Protected microcontroller

The microprocessor and extended microcontroller modes allow up to 64K-words of external program memory.

The device also has Brown-out Reset circuitry. This allows a device RESET to occur if the device VDD falls below the Brown-out voltage trip point (BVDD). The chip will remain in Brown-out Reset until VDD rises above BVDD.

A UV erasable, CERQUAD packaged version (compatible with PLCC), is ideal for code development, while the cost-effective One-Time-Programmable (OTP) version is suitable for production in any volume.

The PIC17C7XX fits perfectly in applications that require extremely fast execution of complex software programs. These include applications ranging from precise motor control and industrial process control to automotive, instrumentation, and telecom applications.

The EPROM technology makes customization of application programs (with unique security codes, combinations, model numbers, parameter storage, etc.) fast and convenient. Small footprint package options (including die sales) make the PIC17C7XX ideal for applications with space limitations that require high performance.

High speed execution, powerful peripheral features, flexible I/O, and low power consumption all at low cost make the PIC17C7XX ideal for a wide range of embedded control applications.

1.1 Family and Upward Compatibility

The PIC17CXXX family of microcontrollers have architectural enhancements over the PIC16C5X and PIC16CXX families. These enhancements allow the device to be more efficient in software and hardware requirements. Refer to Appendix A for a detailed list of enhancements and modifications. Code written for PIC16C5X or PIC16CXX can be easily ported to PIC17CXXX devices (Appendix B).

1.2 Development Support

The PIC17CXXX family is supported by a full featured macro assembler, a software simulator, an in-circuit emulator, a universal programmer, a "C" compiler and fuzzy logic support tools. For additional information, see Section 19.0.

PIC17C7XX

TABLE 1-1: PIC17CXXX FAMILY OF DEVICES

Features		PIC17C42A	PIC17C43	PIC17C44	PIC17C752	PIC17C756A	PIC17C762	PIC17C766
Maximum Frequency of Operation		33 MHz	33 MHz	33 MHz	33 MHz	33 MHz	33 MHz	33 MHz
Operating Voltage Range		2.5 - 6.0V	2.5 - 6.0V	2.5 - 6.0V	3.0 - 5.5V	3.0 - 5.5V	3.0 - 5.5V	3.0 - 5.5V
Program Memory (x16)	(EPROM)	2 K	4 K	8 K	8 K	16 K	8 K	16 K
	(ROM)	—	—	—	—	—	—	—
Data Memory (bytes)		232	454	454	678	902	678	902
Hardware Multiplier (8 x 8)		Yes	Yes	Yes	Yes	Yes	Yes	Yes
Timer0 (16-bit + 8-bit postscaler)		Yes	Yes	Yes	Yes	Yes	Yes	Yes
Timer1 (8-bit)		Yes	Yes	Yes	Yes	Yes	Yes	Yes
Timer2 (8-bit)		Yes	Yes	Yes	Yes	Yes	Yes	Yes
Timer3 (16-bit)		Yes	Yes	Yes	Yes	Yes	Yes	Yes
Capture inputs (16-bit)		2	2	2	4	4	4	4
PWM outputs (up to 10-bit)		2	2	2	3	3	3	3
USART/SCI		1	1	1	2	2	2	2
A/D channels (10-bit)		—	—	—	12	12	16	16
SSP (SPI/I ² C w/Master mode)		—	—	—	Yes	Yes	Yes	Yes
Power-on Reset		Yes	Yes	Yes	Yes	Yes	Yes	Yes
Watchdog Timer		Yes	Yes	Yes	Yes	Yes	Yes	Yes
External Interrupts		Yes	Yes	Yes	Yes	Yes	Yes	Yes
Interrupt Sources		11	11	11	18	18	18	18
Code Protect		Yes	Yes	Yes	Yes	Yes	Yes	Yes
Brown-out Reset		—	—	—	Yes	Yes	Yes	Yes
In-Circuit Serial Programming		—	—	—	Yes	Yes	Yes	Yes
I/O Pins		33	33	33	50	50	66	66
I/O High Current Capability	Source	25 mA	25 mA	25 mA	25 mA	25 mA	25 mA	25 mA
	Sink	25 mA ⁽¹⁾	25 mA ⁽¹⁾	25 mA ⁽¹⁾	25 mA ⁽¹⁾	25 mA ⁽¹⁾	25 mA ⁽¹⁾	25 mA ⁽¹⁾
Package Types		40-pin DIP 44-pin PLCC 44-pin MQFP 44-pin TQFP	40-pin DIP 44-pin PLCC 44-pin MQFP 44-pin TQFP	40-pin DIP 44-pin PLCC 44-pin MQFP 44-pin TQFP	64-pin TQFP 68-pin PLCC	64-pin TQFP 68-pin PLCC	80-pin TQFP 84-pin PLCC	80-pin TQFP 84-pin PLCC

Note 1: Pins RA2 and RA3 can sink up to 60 mA.

2.0 DEVICE VARIETIES

Each device has a variety of frequency ranges and packaging options. Depending on application and production requirements, the proper device option can be selected using the information in the PIC17C7XX Product Selection System section at the end of this data sheet. When placing orders, please use the "PIC17C7XX Product Identification System" at the back of this data sheet to specify the correct part number. When discussing the functionality of the device, memory technology and voltage range does not matter.

There are two memory type options. These are specified in the middle characters of the part number.

1. **C**, as in PIC17**C**756A. These devices have EPROM type memory.
2. **CR**, as in PIC17**CR**756A. These devices have ROM type memory.

All these devices operate over the standard voltage range. Devices are also offered which operate over an extended voltage range (and reduced frequency range). Table 2-1 shows all possible memory types and voltage range designators for a particular device. These designators are in **bold** typeface.

TABLE 2-1: DEVICE MEMORY VARIETIES

Memory Type	Voltage Range	
	Standard	Extended
EPROM	PIC17 C XXX	PIC17 LC XXX
ROM	PIC17 CR XXX	PIC17 LCR XXX
Note: Not all memory technologies are available for a particular device.		

2.1 UV Erasable Devices

The UV erasable version, offered in CERQUAD package, is optimal for prototype development and pilot programs.

The UV erasable version can be erased and reprogrammed to any of the configuration modes. Third party programmers also are available; refer to the *Third Party Guide* for a list of sources.

2.2 One-Time-Programmable (OTP) Devices

The availability of OTP devices is especially useful for customers expecting frequent code changes and updates.

The OTP devices, packaged in plastic packages, permit the user to program them once. In addition to the program memory, the configuration bits must be programmed.

2.3 Quick-Turnaround-Production (QTP) Devices

Microchip offers a QTP Programming Service for factory production orders. This service is made available for users who choose not to program a medium to high quantity of units and whose code patterns have stabilized. The devices are identical to the OTP devices but with all EPROM locations and configuration options already programmed by the factory. Certain code and prototype verification procedures apply before production shipments are available. Please contact your local Microchip Technology sales office for more details.

2.4 Serialized Quick-Turnaround Production (SQTPsm) Devices

Microchip offers a unique programming service, where a few user defined locations in each device are programmed with different serial numbers. The serial numbers may be random, pseudo-random or sequential.

Serial programming allows each device to have a unique number which can serve as an entry code, password or ID number.

2.5 Read Only Memory (ROM) Devices

Microchip offers masked ROM versions of several of the highest volume parts, thus giving customers a low cost option for high volume, mature products.

ROM devices do not allow serialization information in the program memory space.

For information on submitting ROM code, please contact your regional sales office.

Note: Presently, NO ROM versions of the PIC17C7XX devices are available.

PIC17C7XX

NOTES:

3.0 ARCHITECTURAL OVERVIEW

The high performance of the PIC17CXXX can be attributed to a number of architectural features, commonly found in RISC microprocessors. To begin with, the PIC17CXXX uses a modified Harvard architecture. This architecture has the program and data accessed from separate memories. So, the device has a program memory bus and a data memory bus. This improves bandwidth over traditional von Neumann architecture, where program and data are fetched from the same memory (accesses over the same bus). Separating program and data memory further allows instructions to be sized differently than the 8-bit wide data word. PIC17CXXX opcodes are 16-bits wide, enabling single word instructions. The full 16-bit wide program memory bus fetches a 16-bit instruction in a single cycle. A two-stage pipeline overlaps fetch and execution of instructions. Consequently, all instructions execute in a single cycle (121 ns @ 33 MHz), except for program branches and two special instructions that transfer data between program and data memory.

The PIC17CXXX can address up to 64K x 16 of program memory space.

The **PIC17C752** and **PIC17C762** integrate 8K x 16 of EPROM program memory on-chip.

The **PIC17C756A** and **PIC17C766** integrate 16K x 16 EPROM program memory on-chip.

A simplified block diagram is shown in Figure 3-1. The descriptions of the device pins are listed in Table 3-1.

Program execution can be internal only (Microcontroller or Protected Microcontroller mode), external only (Microprocessor mode), or both (Extended Microcontroller mode). Extended Microcontroller mode does not allow code protection.

The PIC17CXXX can directly or indirectly address its register files or data memory. All special function registers, including the Program Counter (PC) and Working Register (WREG), are mapped in data memory. The PIC17CXXX has an orthogonal (symmetrical) instruction set that makes it possible to carry out any operation on any register using any addressing mode. This symmetrical nature and lack of 'special optimal situations' make programming with the PIC17CXXX simple, yet efficient. In addition, the learning curve is reduced significantly.

One of the PIC17CXXX family architectural enhancements from the PIC16CXX family, allows two file registers to be used in some two operand instructions. This allows data to be moved directly between two registers without going through the WREG register, thus increasing performance and decreasing program memory usage.

The PIC17CXXX devices contain an 8-bit ALU and working register. The ALU is a general purpose arithmetic unit. It performs arithmetic and Boolean functions between data in the working register and any register file.

The WREG register is an 8-bit working register used for ALU operations.

All PIC17CXXX devices have an 8 x 8 hardware multiplier. This multiplier generates a 16-bit result in a single cycle.

The ALU is 8-bits wide and capable of addition, subtraction, shift and logical operations. Unless otherwise mentioned, arithmetic operations are two's complement in nature.

Depending on the instruction executed, the ALU may affect the values of the Carry (C), Digit Carry (DC), Zero (Z) and Overflow (OV) bits in the ALUSTA register. The C and DC bits operate as a borrow and digit borrow out bit, respectively, in subtraction. See the SUBLW and SUBWF instructions for examples.

Signed arithmetic is comprised of a magnitude and a sign bit. The overflow bit indicates if the magnitude overflows and causes the sign bit to change state. That is, if the result of 8-bit signed operations is greater than 127 (7Fh), or less than -128 (80h).

Signed math can have greater than 7-bit values (magnitude), if more than one byte is used. The overflow bit only operates on bit6 (MSb of magnitude) and bit7 (sign bit) of each byte value in the ALU. That is, the overflow bit is not useful if trying to implement signed math where the magnitude, for example, is 11-bits.

If the signed math values are greater than 7-bits (such as 15-, 24-, or 31-bit), the algorithm must ensure that the low order bytes of the signed value ignore the overflow status bit.

Example 3-1 shows two cases of doing signed arithmetic. The Carry (C) bit and the Overflow (OV) bit are the most important status bits for signed math operations.

EXAMPLE 3-1: 8-BIT MATH ADDITION

Hex Value	Signed Values	Unsigned Values
FFh	-1	255
+ 01h	+ 1	+ 1
= 00h	= 0 (FEh)	= 256 → 00h
C bit = 1	C bit = 1	C bit = 1
OV bit = 0	OV bit = 0	OV bit = 0
DC bit = 1	DC bit = 1	DC bit = 1
Z bit = 1	Z bit = 1	Z bit = 1
Hex Value	Signed Values	Unsigned Values
7Fh	127	127
+ 01h	+ 1	+ 1
= 80h	= 128 → 00h	= 128
C bit = 0	C bit = 0	C bit = 0
OV bit = 1	OV bit = 1	OV bit = 1
DC bit = 1	DC bit = 1	DC bit = 1
Z bit = 0	Z bit = 0	Z bit = 0

PIC17C7XX

FIGURE 3-1: PIC17C752/756A BLOCK DIAGRAM

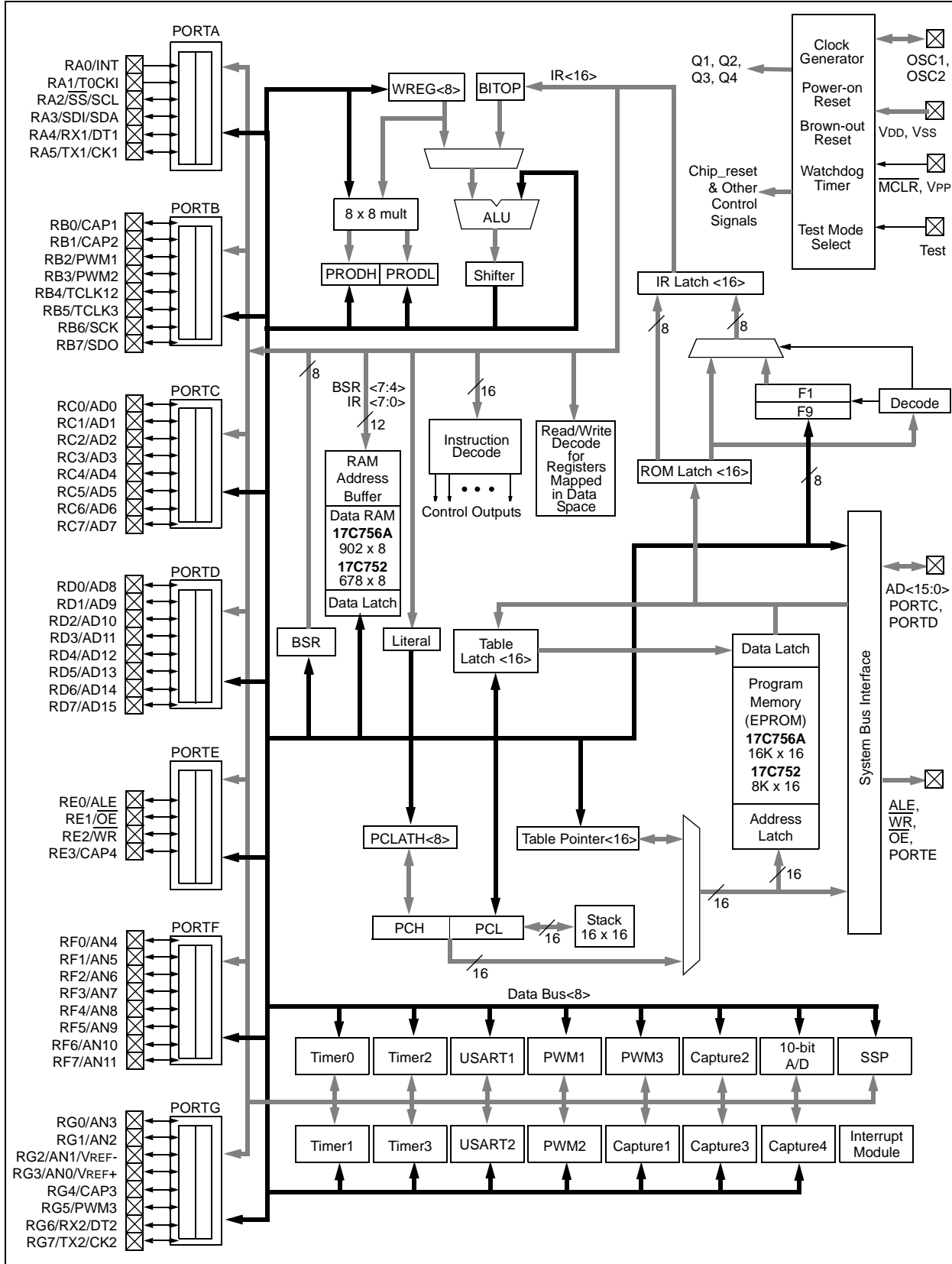
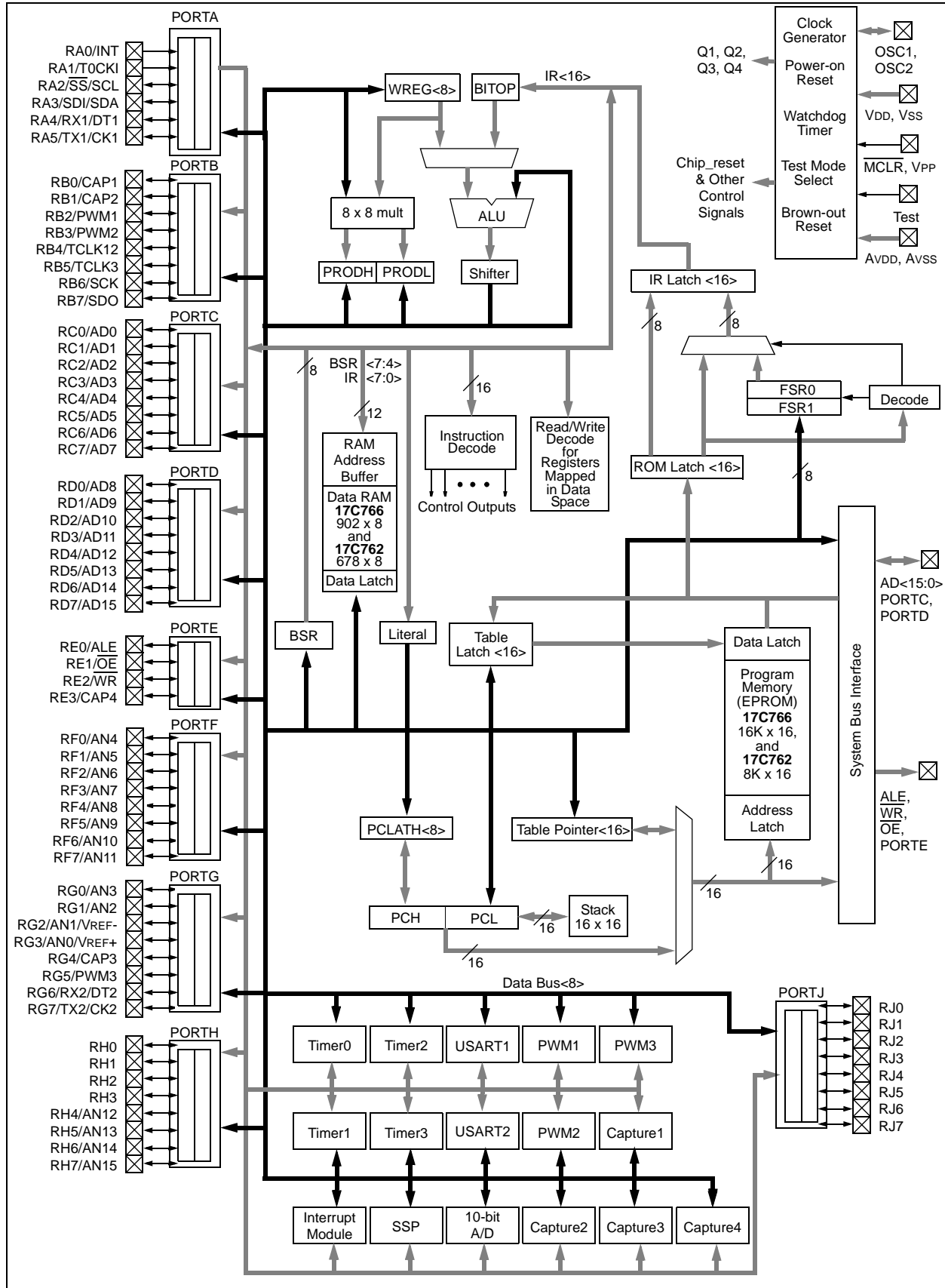

FIGURE 3-2: PIC17C762/766 BLOCK DIAGRAM



PIC17C7XX

TABLE 3-1: PINOUT DESCRIPTIONS

Name	PIC17C75X			PIC17C76X		I/O/P Type	Buffer Type	Description
	DIP No.	PLCC No.	TQFP No.	PLCC No.	QFP No.			
OSC1/CLKIN	47	50	39	62	49	I	ST	Oscillator input in Crystal/Resonator or RC Oscillator mode. External clock input in External Clock mode.
OSC2/CLKOUT	48	51	40	63	50	O	—	Oscillator output. Connects to crystal or resonator in Crystal Oscillator mode. In RC Oscillator or External Clock modes, OSC2 pin outputs CLKOUT which has one fourth the frequency (Fosc/4) of OSC1 and denotes the instruction cycle rate.
MCLR/VPP	15	16	7	20	9	I/P	ST	Master clear (RESET) input or Programming Voltage (VPP) input. This is the active low RESET input to the device.
RA0/INT	56	60	48	72	58	I	ST	<p>PORTA pins have individual differentiations that are listed in the following descriptions:</p> <p>RA0 can also be selected as an external interrupt input. Interrupt can be configured to be on positive or negative edge. Input only pin.</p> <p>RA1 can also be selected as an external interrupt input and the interrupt can be configured to be on positive or negative edge. RA1 can also be selected to be the clock input to the Timer0 timer/counter. Input only pin.</p> <p>RA2 can also be used as the slave select input for the SPI or the clock input for the I²C bus. High voltage, high current, open drain port pin.</p> <p>RA3 can also be used as the data input for the SPI or the data for the I²C bus. High voltage, high current, open drain port pin.</p> <p>RA4 can also be selected as the USART1 (SCI) Asynchronous Receive or USART1 (SCI) Synchronous Data. Output available from USART only.</p> <p>RA5 can also be selected as the USART1 (SCI) Asynchronous Transmit or USART1 (SCI) Synchronous Clock. Output available from USART only.</p>
RA1/T0CKI	41	44	33	56	43	I	ST	
RA2/ \overline{SS} /SCL	42	45	34	57	44	I/O ⁽²⁾	ST	
RA3/SDI/SDA	43	46	35	58	45	I/O ⁽²⁾	ST	
RA4/RX1/DT1	40	43	32	51	38	I/O ⁽¹⁾	ST	
RA5/TX1/CK1	39	42	31	50	37	I/O ⁽¹⁾	ST	
RB0/CAP1	55	59	47	71	57	I/O	ST	<p>PORTB is a bi-directional I/O Port with software configurable weak pull-ups.</p> <p>RB0 can also be the Capture1 input pin.</p> <p>RB1 can also be the Capture2 input pin.</p> <p>RB2 can also be the PWM1 output pin.</p> <p>RB3 can also be the PWM2 output pin.</p> <p>RB4 can also be the external clock input to Timer1 and Timer2.</p> <p>RB5 can also be the external clock input to Timer3.</p> <p>RB6 can also be used as the master/slave clock for the SPI.</p> <p>RB7 can also be used as the data output for the SPI.</p>
RB1/CAP2	54	58	46	70	56	I/O	ST	
RB2/PWM1	50	54	42	66	52	I/O	ST	
RB3/PWM2	53	57	45	69	55	I/O	ST	
RB4/TCLK12	52	56	44	68	54	I/O	ST	
RB5/TCLK3	51	55	43	67	53	I/O	ST	
RB6/SCK	44	47	36	59	46	I/O	ST	
RB7/SDO	45	48	37	60	47	I/O	ST	

Legend: I = Input only; O = Output only; I/O = Input/Output; P = Power; — = Not Used; TTL = TTL input; ST = Schmitt Trigger input

Note 1: The output is only available by the peripheral operation.
Note 2: Open drain input/output pin. Pin forced to input upon any device RESET.

TABLE 3-1: PINOUT DESCRIPTIONS (CONTINUED)

Name	PIC17C75X			PIC17C76X		I/O/P Type	Buffer Type	Description
	DIP No.	PLCC No.	TQFP No.	PLCC No.	QFP No.			
RC0/AD0	2	3	58	3	72	I/O	TTL	PORTC is a bi-directional I/O Port. This is also the least significant byte (LSB) of the 16-bit wide system bus in Microprocessor mode or Extended Microcontroller mode. In multiplexed system bus configuration, these pins are address output as well as data input or output.
RC1/AD1	63	67	55	83	69	I/O	TTL	
RC2/AD2	62	66	54	82	68	I/O	TTL	
RC3/AD3	61	65	53	81	67	I/O	TTL	
RC4/AD4	60	64	52	80	66	I/O	TTL	
RC5/AD5	58	63	51	79	65	I/O	TTL	
RC6/AD6	58	62	50	78	64	I/O	TTL	
RC7/AD7	57	61	49	77	63	I/O	TTL	
RD0/AD8	10	11	2	15	4	I/O	TTL	PORTD is a bi-directional I/O Port. This is also the most significant byte (MSB) of the 16-bit system bus in Microprocessor mode or Extended Microcontroller mode. In multiplexed system bus configuration, these pins are address output as well as data input or output.
RD1/AD9	9	10	1	14	3	I/O	TTL	
RD2/AD10	8	9	64	9	78	I/O	TTL	
RD3/AD11	7	8	63	8	77	I/O	TTL	
RD4/AD12	6	7	62	7	76	I/O	TTL	
RD5/AD13	5	6	61	6	75	I/O	TTL	
RD6/AD14	4	5	60	5	74	I/O	TTL	
RD7/AD15	3	4	59	4	73	I/O	TTL	
RE0/ALE	11	12	3	16	5	I/O	TTL	PORTE is a bi-directional I/O Port. In Microprocessor mode or Extended Microcontroller mode, RE0 is the Address Latch Enable (ALE) output. Address should be latched on the falling edge of ALE output. In Microprocessor or Extended Microcontroller mode, RE1 is the Output Enable (\overline{OE}) control output (active low). In Microprocessor or Extended Microcontroller mode, RE2 is the Write Enable (\overline{WR}) control output (active low). RE3 can also be the Capture4 input pin.
RE1/ \overline{OE}	12	13	4	17	6	I/O	TTL	
RE2/ \overline{WR}	13	14	5	18	7	I/O	TTL	
RE3/CAP4	14	15	6	19	8	I/O	ST	
RF0/AN4	26	28	18	36	24	I/O	ST	PORTF is a bi-directional I/O Port. RF0 can also be analog input 4. RF1 can also be analog input 5. RF2 can also be analog input 6. RF3 can also be analog input 7. RF4 can also be analog input 8. RF5 can also be analog input 9. RF6 can also be analog input 10. RF7 can also be analog input 11.
RF1/AN5	25	27	17	35	23	I/O	ST	
RF2/AN6	24	26	16	30	18	I/O	ST	
RF3/AN7	23	25	15	29	17	I/O	ST	
RF4/AN8	22	24	14	28	16	I/O	ST	
RF5/AN9	21	23	13	27	15	I/O	ST	
RF6/AN10	20	22	12	26	14	I/O	ST	
RF7/AN11	19	21	11	25	13	I/O	ST	

Legend: I = Input only; O = Output only; I/O = Input/Output;
 P = Power; — = Not Used; TTL = TTL input; ST = Schmitt Trigger input

- Note 1:** The output is only available by the peripheral operation.
Note 2: Open drain input/output pin. Pin forced to input upon any device RESET.

PIC17C7XX

TABLE 3-1: PINOUT DESCRIPTIONS (CONTINUED)

Name	PIC17C75X			PIC17C76X		I/O/P Type	Buffer Type	Description
	DIP No.	PLCC No.	TQFP No.	PLCC No.	QFP No.			
RG0/AN3	32	34	24	42	30	I/O	ST	PORTG is a bi-directional I/O Port. RG0 can also be analog input 3. RG1 can also be analog input 2. RG2 can also be analog input 1, or the ground reference voltage. RG3 can also be analog input 0, or the positive reference voltage. RG4 can also be the Capture3 input pin. RG5 can also be the PWM3 output pin. RG6 can also be selected as the USART2 (SCI) Asynchronous Receive or USART2 (SCI) Synchronous Data. RG7 can also be selected as the USART2 (SCI) Asynchronous Transmit or USART2 (SCI) Synchronous Clock.
RG1/AN2	31	33	23	41	29	I/O	ST	
RG2/AN1/VREF-	30	32	22	40	28	I/O	ST	
RG3/AN0/VREF+	29	31	21	39	27	I/O	ST	
RG4/CAP3	35	38	27	46	33	I/O	ST	
RG5/PWM3	36	39	28	47	34	I/O	ST	
RG6/RX2/DT2	38	41	30	49	36	I/O	ST	
RG7/TX2/CK2	37	40	29	48	35	I/O	ST	
RH0	—	—	—	10	79	I/O	ST	PORTH is a bi-directional I/O Port. PORTH is only available on the PIC17C76X devices. RH4 can also be analog input 12. RH5 can also be analog input 13. RH6 can also be analog input 14. RH7 can also be analog input 15.
RH1	—	—	—	11	80	I/O	ST	
RH2	—	—	—	12	1	I/O	ST	
RH3	—	—	—	13	2	I/O	ST	
RH4/AN12	—	—	—	31	19	I/O	ST	
RH5/AN13	—	—	—	32	20	I/O	ST	
RH6/AN14	—	—	—	33	21	I/O	ST	
RH7/AN15	—	—	—	34	22	I/O	ST	
RJ0	—	—	—	52	39	I/O	ST	PORTJ is a bi-directional I/O Port. PORTJ is only available on the PIC17C76X devices.
RJ1	—	—	—	53	40	I/O	ST	
RJ2	—	—	—	54	41	I/O	ST	
RJ3	—	—	—	55	42	I/O	ST	
RJ4	—	—	—	73	59	I/O	ST	
RJ5	—	—	—	74	60	I/O	ST	
RJ6	—	—	—	75	61	I/O	ST	
RJ7	—	—	—	76	62	I/O	ST	
TEST	16	17	8	21	10	I	ST	Test mode selection control input. Always tie to Vss for normal operation.
Vss	17, 33, 49, 64	19, 36, 53, 68	9, 25, 41, 56	23, 44, 65, 84	11, 31, 51, 70	P		Ground reference for logic and I/O pins.
VDD	1, 18, 34, 46	2, 20, 37, 49	10, 26, 38, 57	24, 45, 61, 2	12, 32, 48, 71	P		Positive supply for logic and I/O pins.
AVss	28	30	20	38	26	P		Ground reference for A/D converter. This pin MUST be at the same potential as Vss.
AVDD	27	29	19	37	25	P		Positive supply for A/D converter. This pin MUST be at the same potential as VDD.
NC	—	1, 18, 35, 52	—	1, 22, 43, 64	—			No Connect. Leave these pins unconnected.

Legend: I = Input only; O = Output only; I/O = Input/Output;
P = Power; — = Not Used; TTL = TTL input; ST = Schmitt Trigger input

Note 1: The output is only available by the peripheral operation.
Note 2: Open drain input/output pin. Pin forced to input upon any device RESET.

4.0 ON-CHIP OSCILLATOR CIRCUIT

The internal oscillator circuit is used to generate the device clock. Four device clock periods generate an internal instruction clock (T_{CY}).

There are four modes that the oscillator can operate in. They are selected by the device configuration bits during device programming. These modes are:

- LF Low Frequency ($F_{OSC} \leq 2$ MHz)
- XT Standard Crystal/Resonator Frequency (2 MHz $\leq F_{OSC} \leq 33$ MHz)
- EC External Clock Input (Default oscillator configuration)
- RC External Resistor/Capacitor ($F_{OSC} \leq 4$ MHz)

There are two timers that offer necessary delays on power-up. One is the Oscillator Start-up Timer (OST), intended to keep the chip in RESET until the crystal oscillator is stable. The other is the Power-up Timer (PWRT), which provides a fixed delay of 96 ms (nominal) on POR and BOR. The PWRT is designed to keep the part in RESET while the power supply stabilizes. With these two timers on-chip, most applications need no external RESET circuitry.

SLEEP mode is designed to offer a very low current power-down mode. The user can wake from SLEEP through external RESET, Watchdog Timer Reset, or through an interrupt.

Several oscillator options are made available to allow the part to better fit the application. The RC oscillator option saves system cost while the LF crystal option saves power. Configuration bits are used to select various options.

4.1 Oscillator Configurations

4.1.1 OSCILLATOR TYPES

The PIC17CXXX can be operated in four different oscillator modes. The user can program two configuration bits ($F_{OSC1}:F_{OSC0}$) to select one of these four modes:

- LF Low Power Crystal
- XT Crystal/Resonator
- EC External Clock Input
- RC Resistor/Capacitor

The main difference between the LF and XT modes is the gain of the internal inverter of the oscillator circuit, which allows the different frequency ranges.

For more details on the device configuration bits, see Section 17.0.

4.1.2 CRYSTAL OSCILLATOR/CERAMIC RESONATORS

In XT or LF modes, a crystal or ceramic resonator is connected to the OSC1/CLKIN and OSC2/CLKOUT pins to establish oscillation (Figure 4-2). The PIC17CXXX oscillator design requires the use of a parallel cut crystal. Use of a series cut crystal may give a frequency out of the crystal manufacturers specifications.

For frequencies above 24 MHz, it is common for the crystal to be an overtone mode crystal. Use of overtone mode crystals require a tank circuit to attenuate the gain at the fundamental frequency. Figure 4-3 shows an example circuit.

4.1.3 OSCILLATOR/RESONATOR START-UP

As the device voltage increases from V_{SS} , the oscillator will start its oscillations. The time required for the oscillator to start oscillating depends on many factors. These include:

- Crystal/resonator frequency
- Capacitor values used (C1 and C2)
- Device V_{DD} rise time
- System temperature
- Series resistor value (and type) if used
- Oscillator mode selection of device (which selects the gain of the internal oscillator inverter)

Figure 4-1 shows an example of a typical oscillator/resonator start-up. The peak-to-peak voltage of the oscillator waveform can be quite low (less than 50% of device V_{DD}) when the waveform is centered at $V_{DD}/2$ (refer to parameter #D033 and parameter #D043 in the electrical specification section).

FIGURE 4-1: OSCILLATOR/RESONATOR START-UP CHARACTERISTICS

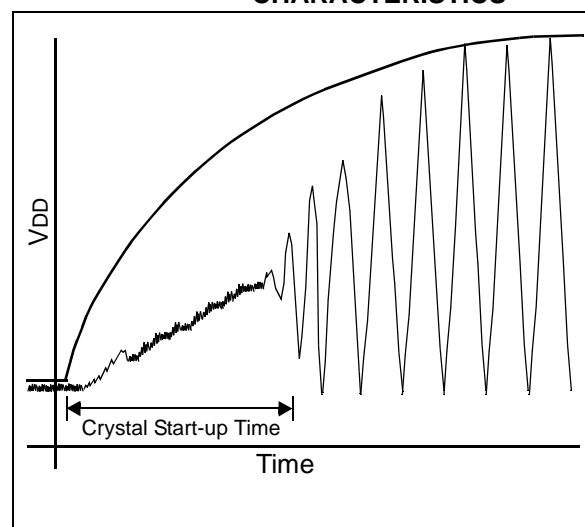

PIC17C7XX

FIGURE 4-2: CRYSTAL OR CERAMIC RESONATOR OPERATION (XT OR LF OSC CONFIGURATION)

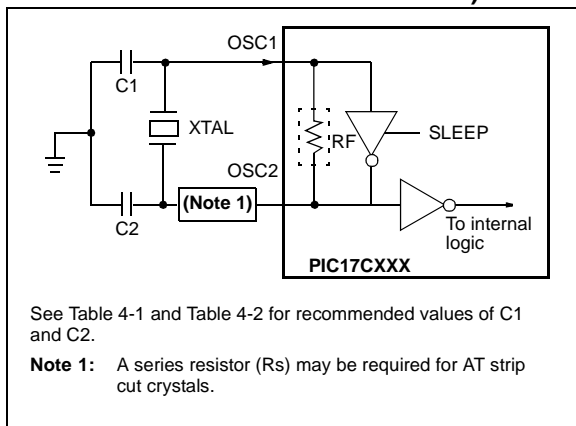

FIGURE 4-3: CRYSTAL OPERATION, OVERTONE CRYSTALS (XT OSC CONFIGURATION)

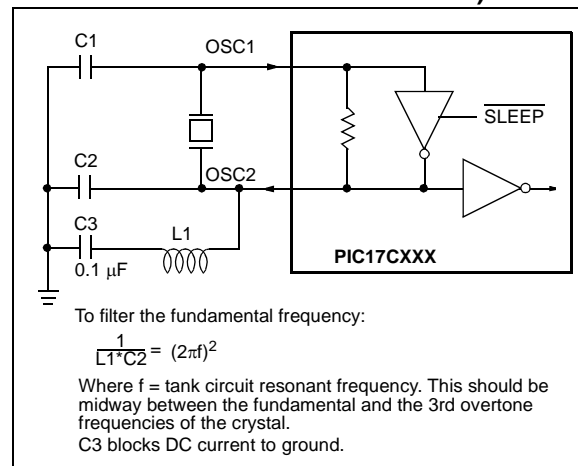

TABLE 4-1: CAPACITOR SELECTION FOR CERAMIC RESONATORS

Oscillator Type	Resonator Frequency	Capacitor Range C1 = C2 ⁽¹⁾
LF	455 kHz	15 - 68 pF
	2.0 MHz	10 - 33 pF
XT	4.0 MHz	22 - 68 pF
	8.0 MHz	33 - 100 pF
	16.0 MHz	33 - 100 pF

Higher capacitance increases the stability of the oscillator, but also increases the start-up time. These values are for design guidance only. Since each resonator has its own characteristics, the user should consult the resonator manufacturer for appropriate values of external components.

Note 1: These values include all board capacitances on this pin. Actual capacitor value depends on board capacitance.

Resonators Used:

455 kHz	Panasonic EFO-A455K04B	± 0.3%
2.0 MHz	Murata Erie CSA2.00MG	± 0.5%
4.0 MHz	Murata Erie CSA4.00MG	± 0.5%
8.0 MHz	Murata Erie CSA8.00MT	± 0.5%
16.0 MHz	Murata Erie CSA16.00MX	± 0.5%

Resonators used did not have built-in capacitors.

TABLE 4-2: CAPACITOR SELECTION FOR CRYSTAL OSCILLATOR

Osc Type	Freq	C1 ⁽²⁾	C2 ⁽²⁾
LF	32 kHz	100-150 pF	100-150 pF
	1 MHz	10-68 pF	10-68 pF
	2 MHz	10-68 pF	10-68 pF
XT	2 MHz	47-100 pF	47-100 pF
	4 MHz	15-68 pF	15-68 pF
	8 MHz	15-47 pF	15-47 pF
	16 MHz	15-47 pF	15-47 pF
	24 MHz ⁽¹⁾	15-47 pF	15-47 pF
	32 MHz ⁽¹⁾	10-47 pF	10-47 pF

Higher capacitance increases the stability of the oscillator, but also increases the start-up time and the oscillator current. These values are for design guidance only. RS may be required in XT mode to avoid overdriving the crystals with low drive level specification. Since each crystal has its own characteristics, the user should consult the crystal manufacturer for appropriate values for external components.

Note 1: Overtone crystals are used at 24 MHz and higher. The circuit in Figure 4-3 should be used to select the desired harmonic frequency.

Note 2: These values include all board capacitances on this pin. Actual capacitor value depends on board capacitance.

Crystals Used:

32.768 kHz	Epson C-001R32.768K-A	± 20 PPM
1.0 MHz	ECS-10-13-1	± 50 PPM
2.0 MHz	ECS-20-20-1	± 50 PPM
4.0 MHz	ECS-40-20-1	± 50 PPM
8.0 MHz	ECS ECS-80-S-4	± 50 PPM
	ECS-80-18-1	
16.0 MHz	ECS-160-20-1	± 50 PPM
25 MHz	CTS CTS25M	± 50 PPM
32 MHz	CRYSTEK HF-2	± 50 PPM

4.1.4 EXTERNAL CLOCK OSCILLATOR

In the EC oscillator mode, the OSC1 input can be driven by CMOS drivers. In this mode, the OSC1/CLKIN pin is hi-impedance and the OSC2/CLKOUT pin is the CLKOUT output (4 T_{osc}).

FIGURE 4-4: EXTERNAL CLOCK INPUT OPERATION (EC OSC CONFIGURATION)

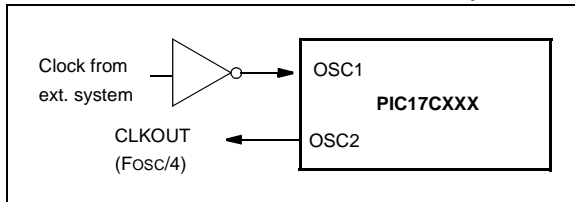

4.1.5 EXTERNAL CRYSTAL OSCILLATOR CIRCUIT

Either a prepackaged oscillator can be used, or a simple oscillator circuit with TTL gates can be built. Prepackaged oscillators provide a wide operating range and better stability. A well designed crystal oscillator will provide good performance with TTL gates. Two types of crystal oscillator circuits can be used: one with series resonance, or one with parallel resonance.

Figure 4-5 shows implementation of a parallel resonant oscillator circuit. The circuit is designed to use the fundamental frequency of the crystal. The 74AS04 inverter performs the 180-degree phase shift that a parallel oscillator requires. The 4.7 k Ω resistor provides the negative feedback for stability. The 10 k Ω potentiometer biases the 74AS04 in the linear region. This could be used for external oscillator designs.

FIGURE 4-5: EXTERNAL PARALLEL RESONANT CRYSTAL OSCILLATOR CIRCUIT

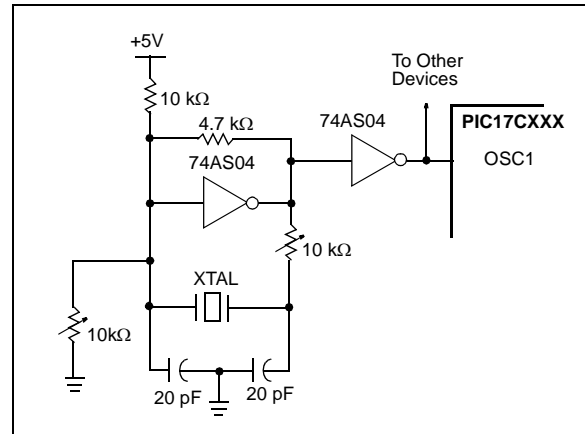
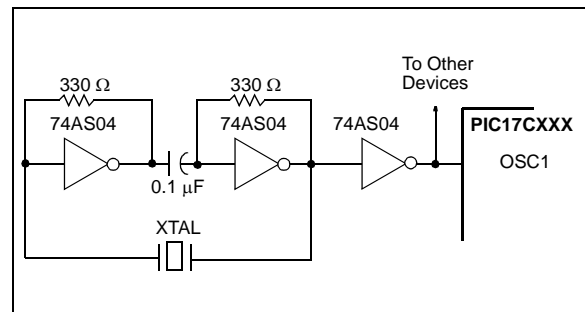

Figure 4-6 shows a series resonant oscillator circuit. This circuit is also designed to use the fundamental frequency of the crystal. The inverter performs a 180-degree phase shift in a series resonant oscillator circuit. The 330 Ω resistors provide the negative feedback to bias the inverters in their linear region.

FIGURE 4-6: EXTERNAL SERIES RESONANT CRYSTAL OSCILLATOR CIRCUIT



PIC17C7XX

4.1.6 RC OSCILLATOR

For timing insensitive applications, the RC device option offers additional cost savings. RC oscillator frequency is a function of the supply voltage, the resistor (R_{EXT}) and capacitor (C_{EXT}) values, and the operating temperature. In addition to this, oscillator frequency will vary from unit to unit due to normal process parameter variation. Furthermore, the difference in lead frame capacitance between package types will also affect oscillation frequency, especially for low C_{EXT} values. The user also needs to take into account variation due to tolerance of external R and C components used. Figure 4-7 shows how the R/C combination is connected to the PIC17CXXX. For R_{EXT} values below 2.2 k Ω , the oscillator operation may become unstable, or stop completely. For very high R_{EXT} values (e.g. 1 M Ω), the oscillator becomes sensitive to noise, humidity and leakage. Thus, we recommend to keep R_{EXT} between 3 k Ω and 100 k Ω .

Although the oscillator will operate with no external capacitor ($C_{EXT} = 0$ pF), we recommend using values above 20 pF for noise and stability reasons. With little or no external capacitance, oscillation frequency can vary dramatically due to changes in external capacitances, such as PCB trace capacitance or package lead frame capacitance.

See Section 21.0 for RC frequency variation from part to part due to normal process variation. The variation is larger for larger R (since leakage current variation will affect RC frequency more for large R) and for smaller C (since variation of input capacitance will affect RC frequency more).

See Section 21.0 for variation of oscillator frequency due to V_{DD} for given R_{EXT}/C_{EXT} values, as well as frequency variation due to operating temperature for given R, C, and V_{DD} values.

The oscillator frequency, divided by 4, is available on the OSC2/CLKOUT pin and can be used for test purposes or to synchronize other logic (see Figure 4-8 for waveform).

FIGURE 4-7: RC OSCILLATOR MODE

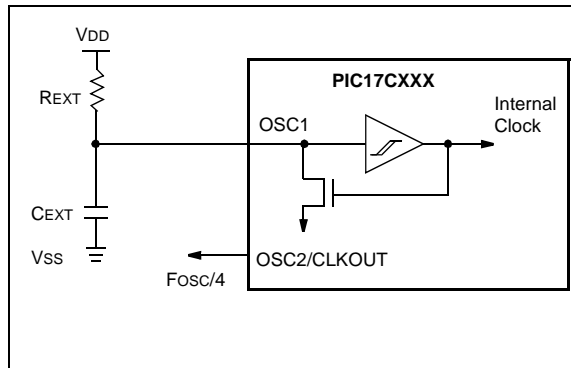

4.1.6.1 RC Start-up

As the device voltage increases, the RC will immediately start its oscillations once the pin voltage levels meet the input threshold specifications (parameter #D032 and parameter #D042 in the electrical specification section). The time required for the RC to start oscillating depends on many factors. These include:

- Resistor value used
- Capacitor value used
- Device V_{DD} rise time
- System temperature

4.2 Clocking Scheme/Instruction Cycle

The clock input (from OSC1) is internally divided by four to generate four non-overlapping quadrature clocks, namely Q1, Q2, Q3 and Q4. Internally, the program counter (PC) is incremented every Q1 and the instruction is fetched from the program memory and latched into the instruction register in Q4. The instruction is decoded and executed during the following Q1 through Q4. The clocks and instruction execution flow are shown in Figure 4-8.

4.3 Instruction Flow/Pipelining

An "Instruction Cycle" consists of four Q cycles (Q1, Q2, Q3 and Q4). The instruction fetch and execute are pipelined such that fetch takes one instruction cycle, while decode and execute takes another instruction cycle. However, due to the pipelining, each instruction effectively executes in one cycle. If an instruction causes the program counter to change (e.g. GOTO), then two cycles are required to complete the instruction (Example 4-1).

A fetch cycle begins with the program counter incrementing in Q1.

In the execution cycle, the fetched instruction is latched into the "Instruction Register (IR)" in cycle Q1. This instruction is then decoded and executed during the Q2, Q3 and Q4 cycles. Data memory is read during Q2 (operand read) and written during Q4 (destination write).

FIGURE 4-8: CLOCK/INSTRUCTION CYCLE

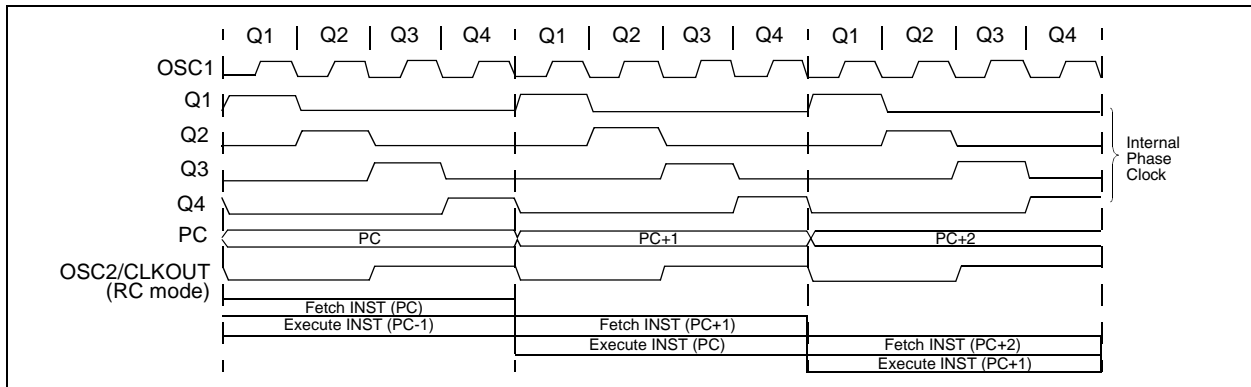

EXAMPLE 4-1: INSTRUCTION PIPELINE FLOW

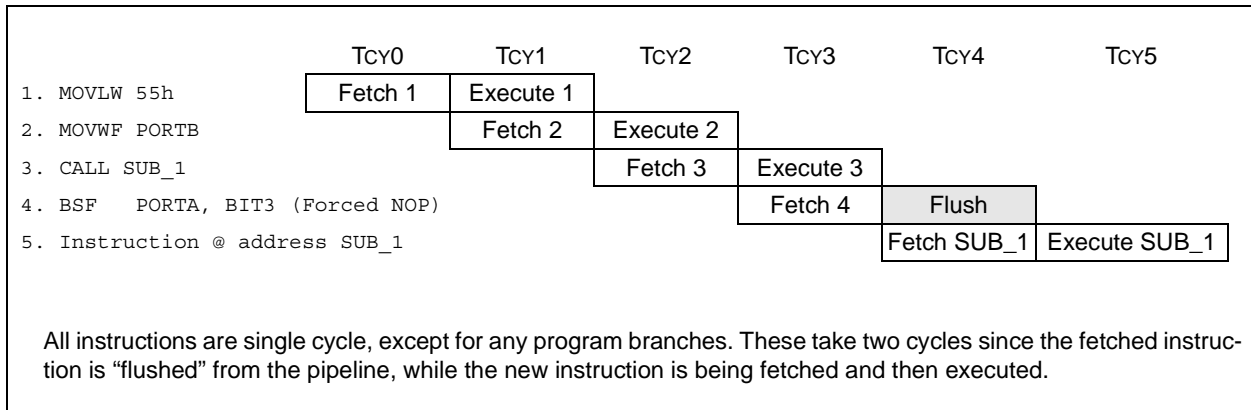

PIC17C7XX

NOTES:

5.0 RESET

The PIC17CXXX differentiates between various kinds of RESET:

- Power-on Reset (POR)
- Brown-out Reset
- MCLR Reset
- WDT Reset

Some registers are not affected in any RESET condition, their status is unknown on POR and unchanged in any other RESET. Most other registers are forced to a "RESET state". The TO and PD bits are set or cleared differently in different RESET situations, as indicated in Table 5-3. These bits, in conjunction with the POR and BOR bits, are used in software to determine the nature of the RESET. See Table 5-4 for a full description of the RESET states of all registers.

When the device enters the "RESET state", the Data Direction registers (DDR) are forced set, which will make the I/O hi-impedance inputs. The RESET state of some peripheral modules may force the I/O to other operations, such as analog inputs or the system bus.

Note: While the device is in a RESET state, the internal phase clock is held in the Q1 state. Any processor mode that allows external execution will force the RE0/ALE pin as a low output and the RE1/OE and RE2/WR pins as high outputs.

A simplified block diagram of the On-Chip Reset Circuit is shown in Figure 5-1.

FIGURE 5-1: SIMPLIFIED BLOCK DIAGRAM OF ON-CHIP RESET CIRCUIT

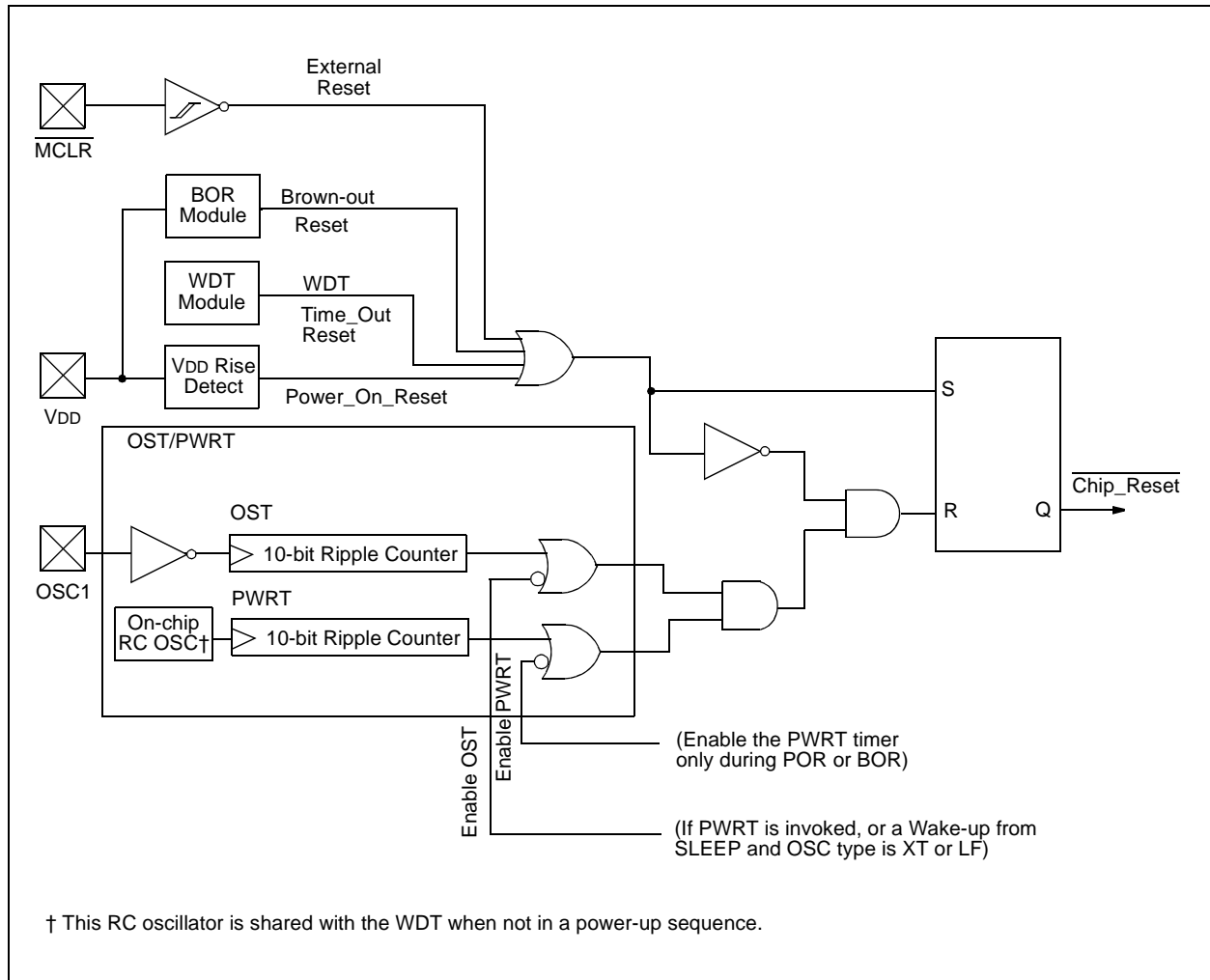

PIC17C7XX

5.1 Power-on Reset (POR), Power-up Timer (PWRT), Oscillator Start-up Timer (OST) and Brown-out Reset (BOR)

5.1.1 POWER-ON RESET (POR)

The Power-on Reset circuit holds the device in RESET until VDD is above the trip point (in the range of 1.4V - 2.3V). The devices produce an internal RESET for both rising and falling VDD. To take advantage of the POR, just tie the MCLR/VPP pin directly (or through a resistor) to VDD. This will eliminate external RC components usually needed to create Power-on Reset. A minimum rise time for VDD is required. See Electrical Specifications for details.

Figure 5-2 and Figure 5-3 show two possible POR circuits.

FIGURE 5-2: USING ON-CHIP POR

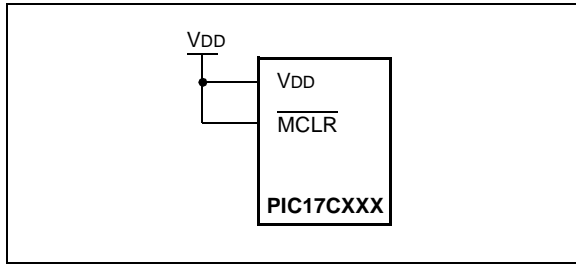
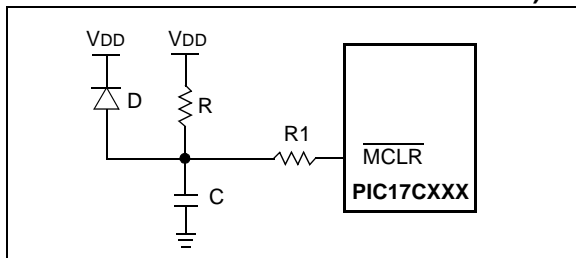

FIGURE 5-3: EXTERNAL POWER-ON RESET CIRCUIT (FOR SLOW VDD POWER-UP)



- Note**
- 1: An external Power-on Reset circuit is required only if VDD power-up time is too slow. The diode D helps discharge the capacitor quickly when VDD powers down.
 - 2: $R < 40 \text{ k}\Omega$ is recommended to ensure that the voltage drop across R does not exceed 0.2V (max. leakage current spec. on the MCLR/VPP pin is 5 μA). A larger voltage drop will degrade VIH level on the MCLR/VPP pin.
 - 3: $R1 = 100\Omega$ to 1 k Ω will limit any current flowing into MCLR from external capacitor C in the event of MCLR/VPP pin breakdown due to Electrostatic Discharge (ESD) or Electrical Overstress (EOS).

5.1.2 POWER-UP TIMER (PWRT)

The Power-up Timer provides a fixed 96 ms time-out (nominal) on power-up. This occurs from the rising edge of the internal POR signal if VDD and MCLR are tied, or after the first rising edge of MCLR (detected high). The Power-up Timer operates on an internal RC oscillator. The chip is kept in RESET as long as the PWRT is active. In most cases, the PWRT delay allows VDD to rise to an acceptable level.

The power-up time delay will vary from chip to chip and with VDD and temperature. See DC parameters for details.

5.1.3 OSCILLATOR START-UP TIMER (OST)

The Oscillator Start-up Timer (OST) provides a 1024 oscillator cycle ($1024T_{osc}$) delay whenever the PWRT is invoked, or a wake-up from SLEEP event occurs in XT or LF mode. The PWRT and OST operate in parallel.

The OST counts the oscillator pulses on the OSC1/CLKIN pin. The counter only starts incrementing after the amplitude of the signal reaches the oscillator input thresholds. This delay allows the crystal oscillator or resonator to stabilize before the device exits RESET. The length of the time-out is a function of the crystal/resonator frequency.

Figure 5-4 shows the operation of the OST circuit. In this figure, the oscillator is of such a low frequency that although enabled simultaneously, the OST does not time-out until after the Power-up Timer time-out.

FIGURE 5-4: OSCILLATOR START-UP TIME (LOW FREQUENCY)

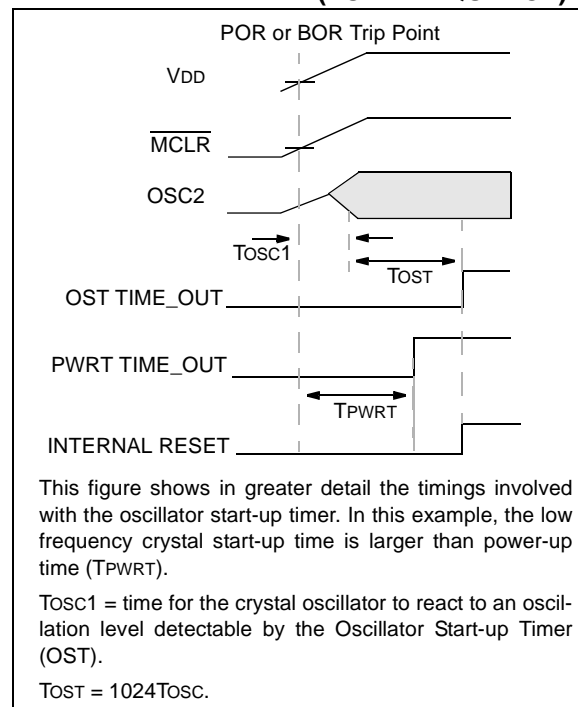

5.1.4 TIME-OUT SEQUENCE

On power-up, the time-out sequence is as follows: First, the internal POR signal goes high when the POR trip point is reached. If MCLR is high, then both the OST and PWRT timers start. In general, the PWRT time-out is longer, except with low frequency crystals/resonators. The total time-out also varies based on oscillator configuration. Table 5-1 shows the times that are associated with the oscillator configuration. Figure 5-5 and Figure 5-6 display these time-out sequences.

If the device voltage is not within electrical specification at the end of a time-out, the MCLR/VPP pin must be held low until the voltage is within the device specification. The use of an external RC delay is sufficient for many of these applications.

The time-out sequence begins from the first rising edge of MCLR.

Table 5-3 shows the RESET conditions for some special registers, while Table 5-4 shows the initialization conditions for all the registers.

TABLE 5-1: TIME-OUT IN VARIOUS SITUATIONS

Oscillator Configuration	POR, BOR	Wake-up from SLEEP	MCLR Reset
XT, LF	Greater of: 96 ms or 1024Tosc	1024Tosc	—
EC, RC	Greater of: 96 ms or 1024Tosc	—	—

TABLE 5-2: STATUS BITS AND THEIR SIGNIFICANCE

POR	BOR ⁽¹⁾	TO	PD	Event
0	0	1	1	Power-on Reset
1	1	1	0	MCLR Reset during SLEEP or interrupt wake-up from SLEEP
1	1	0	1	WDT Reset during normal operation
1	1	0	0	WDT Wake-up during SLEEP
1	1	1	1	MCLR Reset during normal operation
1	0	1	1	Brown-out Reset
0	0	0	x	Illegal, TO is set on POR
0	0	x	0	Illegal, PD is set on POR
x	x	1	1	CLRWDT instruction executed

Note 1: When BODEN is enabled, else the BOR status bit is unknown.

TABLE 5-3: RESET CONDITION FOR THE PROGRAM COUNTER AND THE CPUSTA REGISTER

Event	PCH:PCL	CPUSTA ⁽⁴⁾	OST Active
Power-on Reset	0000h	--11 1100	Yes
Brown-out Reset	0000h	--11 1110	Yes
MCLR Reset during normal operation	0000h	--11 1111	No
MCLR Reset during SLEEP	0000h	--11 1011	Yes ⁽²⁾
WDT Reset during normal operation	0000h	--11 0111	No
WDT Reset during SLEEP ⁽³⁾	0000h	--11 0011	Yes ⁽²⁾
Interrupt Wake-up from SLEEP	GLINTD is set	PC + 1	Yes ⁽²⁾
	GLINTD is clear	PC + 1 ⁽¹⁾	Yes ⁽²⁾

Legend: u = unchanged, x = unknown, - = unimplemented, read as '0'

Note 1: On wake-up, this instruction is executed. The instruction at the appropriate interrupt vector is fetched and then executed.

2: The OST is only active (on wake-up) when the oscillator is configured for XT or LF modes.

3: The Program Counter = 0; that is, the device branches to the RESET vector and places SFRs in WDT Reset states. This is different from the mid-range devices.

4: When BODEN is enabled, else the BOR status bit is unknown.

PIC17C7XX

In Figure 5-5, Figure 5-6 and Figure 5-7, the TPWRT timer time-out is greater than the TOST timer time-out, as would be the case in higher frequency crystals. For lower frequency crystals (i.e., 32 kHz), TOST may be greater.

FIGURE 5-5: TIME-OUT SEQUENCE ON POWER-UP ($\overline{\text{MCLR}}$ TIED TO V_{DD})

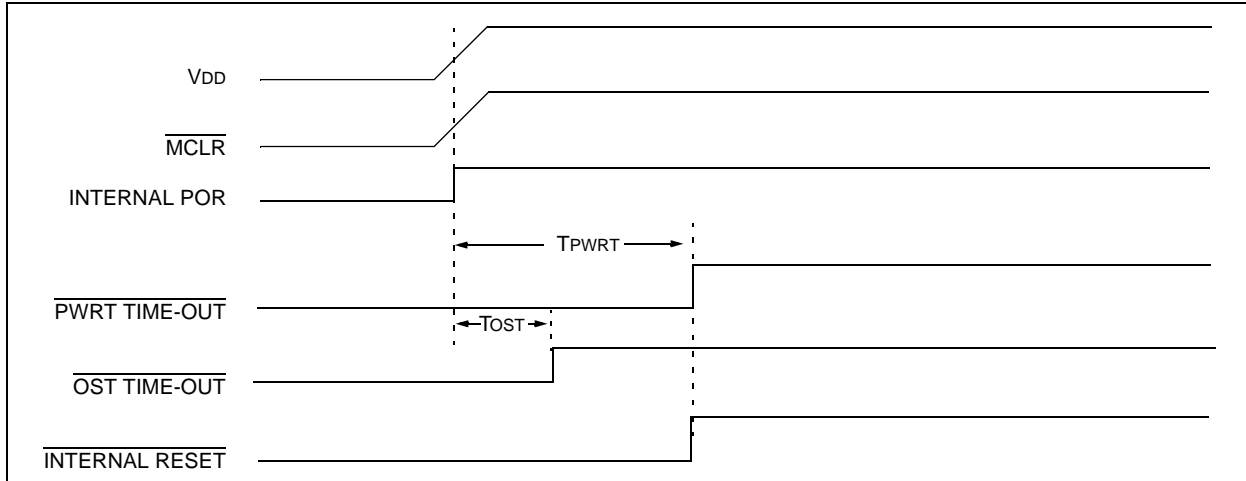

FIGURE 5-6: TIME-OUT SEQUENCE ON POWER-UP ($\overline{\text{MCLR}}$ NOT TIED TO V_{DD})

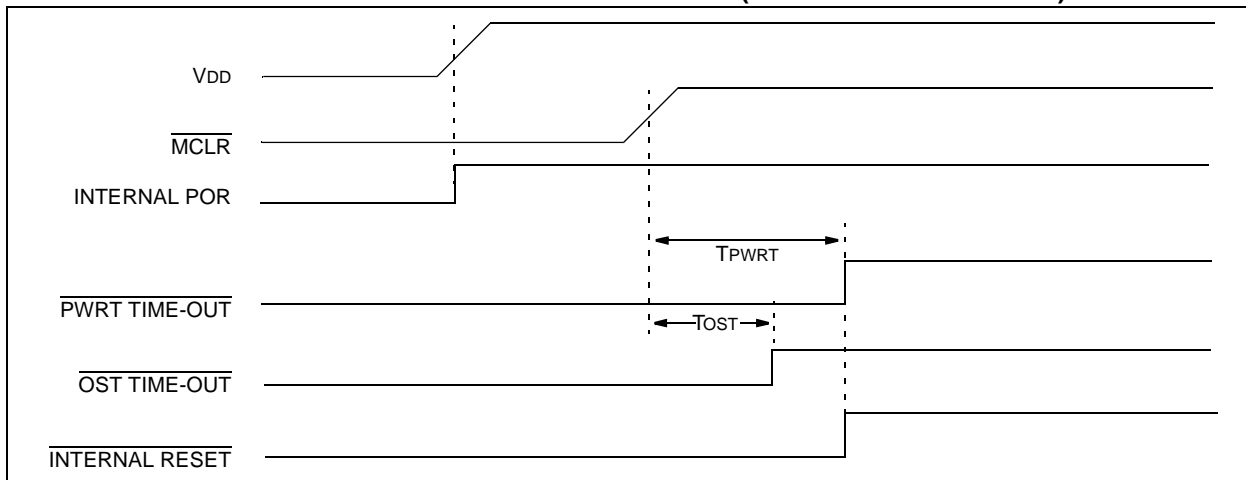

FIGURE 5-7: SLOW RISE TIME ($\overline{\text{MCLR}}$ TIED TO V_{DD})

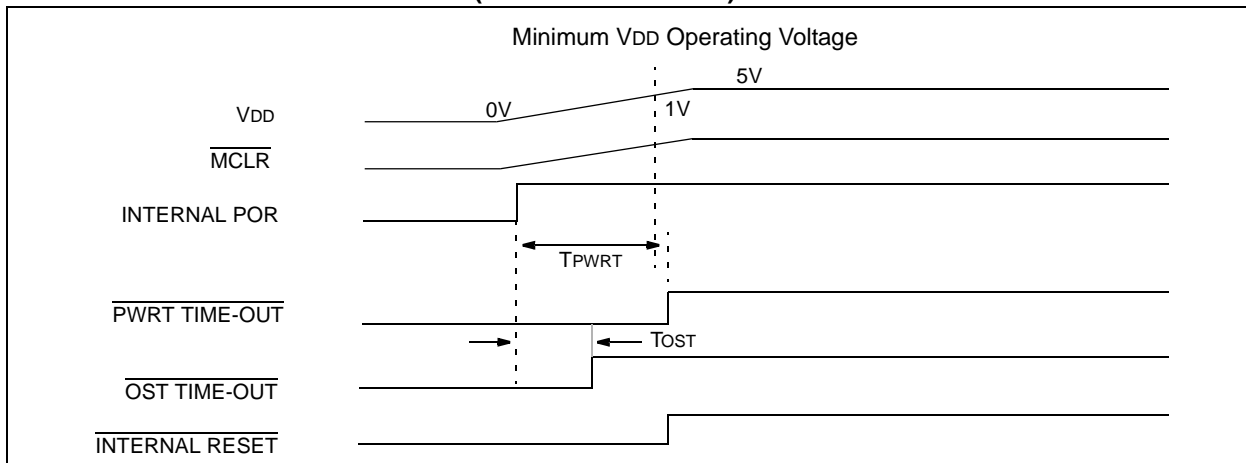

TABLE 5-4: INITIALIZATION CONDITIONS FOR SPECIAL FUNCTION REGISTERS

Register	Address	Power-on Reset Brown-out Reset	MCLR Reset WDT Reset	Wake-up from SLEEP through Interrupt
Unbanked				
INDF0	00h	N/A	N/A	N/A
FSR0	01h	xxxx xxxx	uuuu uuuu	uuuu uuuu
PCL	02h	0000h	0000h	PC + 1 ⁽²⁾
PCLATH	03h	0000 0000	uuuu uuuu	uuuu uuuu
ALUSTA	04h	1111 xxxx	1111 uuuu	1111 uuuu
T0STA	05h	0000 000-	0000 000-	0000 000-
CPUSTA ⁽³⁾	06h	--11 11qq	--11 qquu	--uu qquu
INTSTA	07h	0000 0000	0000 0000	uuuu uuuu ⁽¹⁾
INDF1	08h	N/A	N/A	N/A
FSR1	09h	xxxx xxxx	uuuu uuuu	uuuu uuuu
WREG	0Ah	xxxx xxxx	uuuu uuuu	uuuu uuuu
TMR0L	0Bh	xxxx xxxx	uuuu uuuu	uuuu uuuu
TMR0H	0Ch	xxxx xxxx	uuuu uuuu	uuuu uuuu
TBLPTRL	0Dh	0000 0000	0000 0000	uuuu uuuu
TBLPTRH	0Eh	0000 0000	0000 0000	uuuu uuuu
BSR	0Fh	0000 0000	0000 0000	uuuu uuuu
Bank 0				
PORTA ^(4,6)	10h	0-xx 11xx	0-uu 11uu	u-uu uuuu
DDRB	11h	1111 1111	1111 1111	uuuu uuuu
PORTB ⁽⁴⁾	12h	xxxx xxxx	uuuu uuuu	uuuu uuuu
RCSTA1	13h	0000 -00x	0000 -00u	uuuu -uuu
RCREG1	14h	xxxx xxxx	uuuu uuuu	uuuu uuuu
TXSTA1	15h	0000 --1x	0000 --1u	uuuu --uu
TXREG1	16h	xxxx xxxx	uuuu uuuu	uuuu uuuu
SPBRG1	17h	0000 0000	0000 0000	uuuu uuuu

Legend: u = unchanged, x = unknown, - = unimplemented, read as '0', q = value depends on condition

Note 1: One or more bits in INTSTA, PIR1, PIR2 will be affected (to cause wake-up).

2: When the wake-up is due to an interrupt and the GLINTD bit is cleared, the PC is loaded with the interrupt vector.

3: See Table 5-3 for RESET value of specific condition.

4: This is the value that will be in the port output latch.

5: When the device is configured for Microprocessor or Extended Microcontroller mode, the operation of this port does not rely on these registers.

6: On any device RESET, these pins are configured as inputs.

PIC17C7XX

TABLE 5-4: INITIALIZATION CONDITIONS FOR SPECIAL FUNCTION REGISTERS (CONTINUED)

Register	Address	Power-on Reset Brown-out Reset	MCLR Reset WDT Reset	Wake-up from SLEEP through Interrupt
Bank 1				
DDRC ⁽⁵⁾	10h	1111 1111	1111 1111	uuuu uuuu
PORTC ^(4,5)	11h	xxxx xxxx	uuuu uuuu	uuuu uuuu
DDRD ⁽⁵⁾	12h	1111 1111	1111 1111	uuuu uuuu
PORTD ^(4,5)	13h	xxxx xxxx	uuuu uuuu	uuuu uuuu
DDRE ⁽⁵⁾	14h	---- 1111	---- 1111	---- uuuu
PORTE ^(4,5)	15h	---- xxxx	---- uuuu	---- uuuu
PIR1	16h	x000 0010	u000 0010	uuuu uuuu ⁽¹⁾
PIE1	17h	0000 0000	0000 0000	uuuu uuuu
Bank 2				
TMR1	10h	xxxx xxxx	uuuu uuuu	uuuu uuuu
TMR2	11h	xxxx xxxx	uuuu uuuu	uuuu uuuu
TMR3L	12h	xxxx xxxx	uuuu uuuu	uuuu uuuu
TMR3H	13h	xxxx xxxx	uuuu uuuu	uuuu uuuu
PR1	14h	xxxx xxxx	uuuu uuuu	uuuu uuuu
PR2	15h	xxxx xxxx	uuuu uuuu	uuuu uuuu
PR3/CA1L	16h	xxxx xxxx	uuuu uuuu	uuuu uuuu
PR3/CA1H	17h	xxxx xxxx	uuuu uuuu	uuuu uuuu
Bank 3				
PW1DCL	10h	xx-- ----	uu-- ----	uu-- ----
PW2DCL	11h	xx0- ----	uu0- ----	uuu- ----
PW1DCH	12h	xxxx xxxx	uuuu uuuu	uuuu uuuu
PW2DCH	13h	xxxx xxxx	uuuu uuuu	uuuu uuuu
CA2L	14h	xxxx xxxx	uuuu uuuu	uuuu uuuu
CA2H	15h	xxxx xxxx	uuuu uuuu	uuuu uuuu
TCON1	16h	0000 0000	0000 0000	uuuu uuuu
TCON2	17h	0000 0000	0000 0000	uuuu uuuu

Legend: u = unchanged, x = unknown, - = unimplemented, read as '0', q = value depends on condition

Note 1: One or more bits in INTSTA, PIR1, PIR2 will be affected (to cause wake-up).

2: When the wake-up is due to an interrupt and the GLINTD bit is cleared, the PC is loaded with the interrupt vector.

3: See Table 5-3 for RESET value of specific condition.

4: This is the value that will be in the port output latch.

5: When the device is configured for Microprocessor or Extended Microcontroller mode, the operation of this port does not rely on these registers.

6: On any device RESET, these pins are configured as inputs.

TABLE 5-4: INITIALIZATION CONDITIONS FOR SPECIAL FUNCTION REGISTERS (CONTINUED)

Register	Address	Power-on Reset Brown-out Reset	MCLR Reset WDT Reset	Wake-up from SLEEP through Interrupt
Bank 4				
PIR2	10h	000- 0010	000- 0010	uuu- uuuu ⁽¹⁾
PIE2	11h	000- 0000	000- 0000	uuu- uuuu
Unimplemented	12h	---- ----	---- ----	---- ----
RCSTA2	13h	0000 -00x	0000 -00u	uuuu -uuu
RCREG2	14h	xxxx xxxx	uuuu uuuu	uuuu uuuu
TXSTA2	15h	0000 --1x	0000 --1u	uuuu --uu
TXREG2	16h	xxxx xxxx	uuuu uuuu	uuuu uuuu
SPBRG2	17h	0000 0000	0000 0000	uuuu uuuu
Bank 5				
DDRF	10h	1111 1111	1111 1111	uuuu uuuu
PORTF ⁽⁴⁾	11h	0000 0000	0000 0000	uuuu uuuu
DDRG	12h	1111 1111	1111 1111	uuuu uuuu
PORTG ⁽⁴⁾	13h	xxxx 0000	uuuu 0000	uuuu uuuu
ADCON0	14h	0000 -0-0	0000 -0-0	uuuu uuuu
ADCON1	15h	000- 0000	000- 0000	uuuu uuuu
ADRESL	16h	xxxx xxxx	uuuu uuuu	uuuu uuuu
ADRESH	17h	xxxx xxxx	uuuu uuuu	uuuu uuuu
Bank 6				
SSPADD	10h	0000 0000	0000 0000	uuuu uuuu
SSPCON1	11h	0000 0000	0000 0000	uuuu uuuu
SSPCON2	12h	0000 0000	0000 0000	uuuu uuuu
SSPSTAT	13h	0000 0000	0000 0000	uuuu uuuu
SSPBUF	14h	xxxx xxxx	uuuu uuuu	uuuu uuuu
Unimplemented	15h	---- ----	---- ----	---- ----
Unimplemented	16h	---- ----	---- ----	---- ----
Unimplemented	17h	---- ----	---- ----	---- ----

Legend: u = unchanged, x = unknown, - = unimplemented, read as '0', q = value depends on condition

Note 1: One or more bits in INTSTA, PIR1, PIR2 will be affected (to cause wake-up).

- 2: When the wake-up is due to an interrupt and the GLINTD bit is cleared, the PC is loaded with the interrupt vector.
- 3: See Table 5-3 for RESET value of specific condition.
- 4: This is the value that will be in the port output latch.
- 5: When the device is configured for Microprocessor or Extended Microcontroller mode, the operation of this port does not rely on these registers.
- 6: On any device RESET, these pins are configured as inputs.

PIC17C7XX

TABLE 5-4: INITIALIZATION CONDITIONS FOR SPECIAL FUNCTION REGISTERS (CONTINUED)

Register	Address	Power-on Reset Brown-out Reset	MCLR Reset WDT Reset	Wake-up from SLEEP through Interrupt
Bank 7				
PW3DCL	10h	xx0- ----	uu0- ----	uuu- ----
PW3DCH	11h	xxxx xxxx	uuuu uuuu	uuuu uuuu
CA3L	12h	xxxx xxxx	uuuu uuuu	uuuu uuuu
CA3H	13h	xxxx xxxx	uuuu uuuu	uuuu uuuu
CA4L	14h	xxxx xxxx	uuuu uuuu	uuuu uuuu
CA4H	15h	xxxx xxxx	uuuu uuuu	uuuu uuuu
TCON3	16h	-000 0000	-000 0000	-uuu uuuu
Unimplemented	17h	---- ----	---- ----	---- ----
Bank 8				
DDRH	10h	1111 1111	1111 1111	uuuu uuuu
PORTH ⁽⁴⁾	11h	xxxx xxxx	uuuu uuuu	uuuu uuuu
DDRJ	12h	1111 1111	1111 1111	uuuu uuuu
PORTJ ⁽⁴⁾	13h	xxxx xxxx	uuuu uuuu	uuuu uuuu
Unbanked				
PRODL	18h	xxxx xxxx	uuuu uuuu	uuuu uuuu
PRODH	19h	xxxx xxxx	uuuu uuuu	uuuu uuuu

Legend: u = unchanged, x = unknown, - = unimplemented, read as '0', q = value depends on condition

Note 1: One or more bits in INTSTA, PIR1, PIR2 will be affected (to cause wake-up).

2: When the wake-up is due to an interrupt and the GLINTD bit is cleared, the PC is loaded with the interrupt vector.

3: See Table 5-3 for RESET value of specific condition.

4: This is the value that will be in the port output latch.

5: When the device is configured for Microprocessor or Extended Microcontroller mode, the operation of this port does not rely on these registers.

6: On any device RESET, these pins are configured as inputs.

5.1.5 BROWN-OUT RESET (BOR)

PIC17C7XX devices have on-chip Brown-out Reset circuitry. This circuitry places the device into a RESET when the device voltage falls below a trip point (BVDD). This ensures that the device does not continue program execution outside the valid operation range of the device. Brown-out Resets are typically used in AC line applications, or large battery applications, where large loads may be switched in (such as automotive).

Note: Before using the on-chip Brown-out for a voltage supervisory function, please review the electrical specifications to ensure that they meet your requirements.

The BODEN configuration bit can disable (if clear/programmed), or enable (if set) the Brown-out Reset circuitry. If VDD falls below BVDD (typically 4.0 V, parameter #D005 in electrical specification section), for greater than parameter #35, the Brown-out situation will reset the chip. A RESET is not guaranteed to occur if VDD falls below BVDD for less than parameter #35. The chip will remain in Brown-out Reset until VDD rises above BVDD. The Power-up Timer and Oscillator Start-up Timer will then be invoked. This will keep the chip in RESET the greater of 96 ms and 1024 TOSC. If VDD drops below BVDD while the Power-up Timer/Oscillator Start-up Timer is running, the chip will go back into a Brown-out Reset. The Power-up Timer/Oscillator Start-up Timer will be initialized. Once VDD rises above BVDD, the Power-up Timer/Oscillator Start-up Timer will start their time delays. Figure 5-10 shows typical Brown-out situations.

In some applications, the Brown-out Reset trip point of the device may not be at the desired level. Figure 5-8 and Figure 5-9 are two examples of external circuitry

that may be implemented. Each needs to be evaluated to determine if they match the requirements of the application.

FIGURE 5-8: EXTERNAL BROWN-OUT PROTECTION CIRCUIT 1

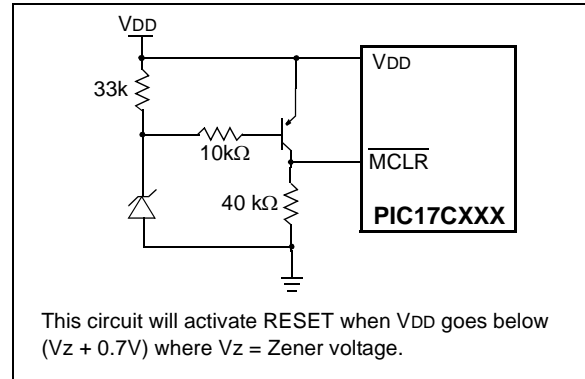

FIGURE 5-9: EXTERNAL BROWN-OUT PROTECTION CIRCUIT 2

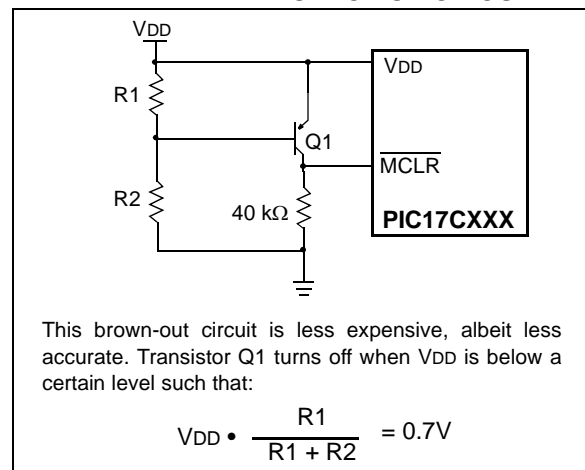
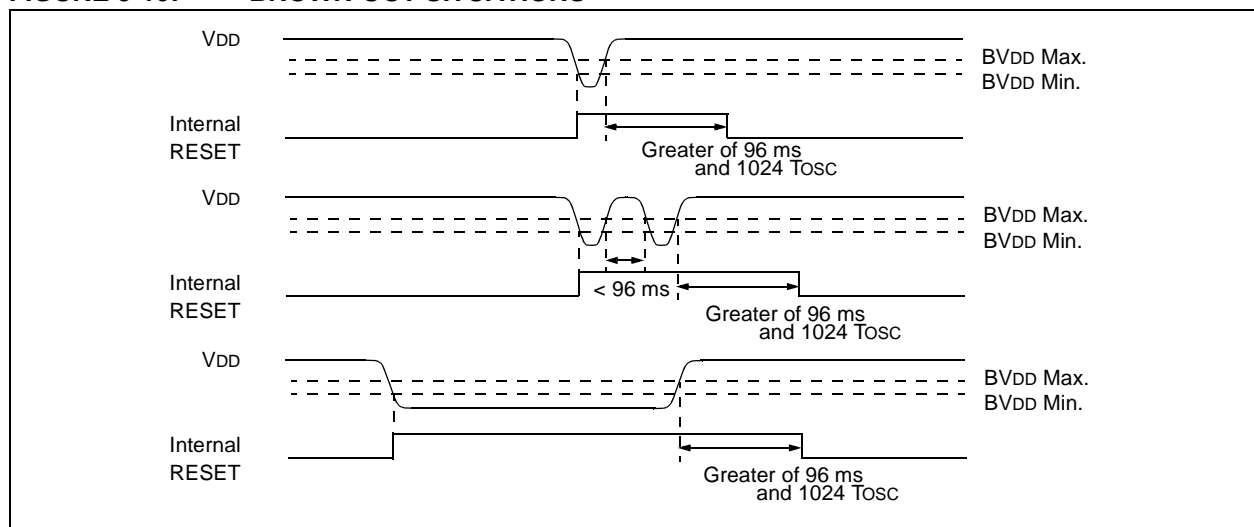

FIGURE 5-10: BROWN-OUT SITUATIONS



PIC17C7XX

NOTES:

6.0 INTERRUPTS

PIC17C7XX devices have 18 sources of interrupt:

- External interrupt from the RA0/INT pin
- Change on RB7:RB0 pins
- TMR0 Overflow
- TMR1 Overflow
- TMR2 Overflow
- TMR3 Overflow
- USART1 Transmit buffer empty
- USART1 Receive buffer full
- USART2 Transmit buffer empty
- USART2 Receive buffer full
- SSP Interrupt
- SSP I²C bus collision interrupt
- A/D conversion complete
- Capture1
- Capture2
- Capture3
- Capture4
- T0CKI edge occurred

There are six registers used in the control and status of interrupts. These are:

- CPUSTA
- INTSTA
- PIE1
- PIR1
- PIE2
- PIR2

The CPUSTA register contains the GLINTD bit. This is the Global Interrupt Disable bit. When this bit is set, all interrupts are disabled. This bit is part of the controller core functionality and is described in the Section 6.4.

When an interrupt is responded to, the GLINTD bit is automatically set to disable any further interrupts, the return address is pushed onto the stack and the PC is loaded with the interrupt vector address. There are four interrupt vectors. Each vector address is for a specific interrupt source (except the peripheral interrupts, which all vector to the same address). These sources are:

- External interrupt from the RA0/INT pin
- TMR0 Overflow
- T0CKI edge occurred
- Any peripheral interrupt

When program execution vectors to one of these interrupt vector addresses (except for the peripheral interrupts), the interrupt flag bit is automatically cleared. Vectoring to the peripheral interrupt vector address does not automatically clear the source of the interrupt. In the peripheral Interrupt Service Routine, the source(s) of the interrupt can be determined by testing the interrupt flag bits. The interrupt flag bit(s) must be cleared in software before re-enabling interrupts to avoid infinite interrupt requests.

When an interrupt condition is met, that individual interrupt flag bit will be set, regardless of the status of its corresponding mask bit or the GLINTD bit.

For external interrupt events, there will be an interrupt latency. For two-cycle instructions, the latency could be one instruction cycle longer.

The “return from interrupt” instruction, `RETFIE`, can be used to mark the end of the Interrupt Service Routine. When this instruction is executed, the stack is “POPed” and the GLINTD bit is cleared (to re-enable interrupts).

FIGURE 6-1: INTERRUPT LOGIC

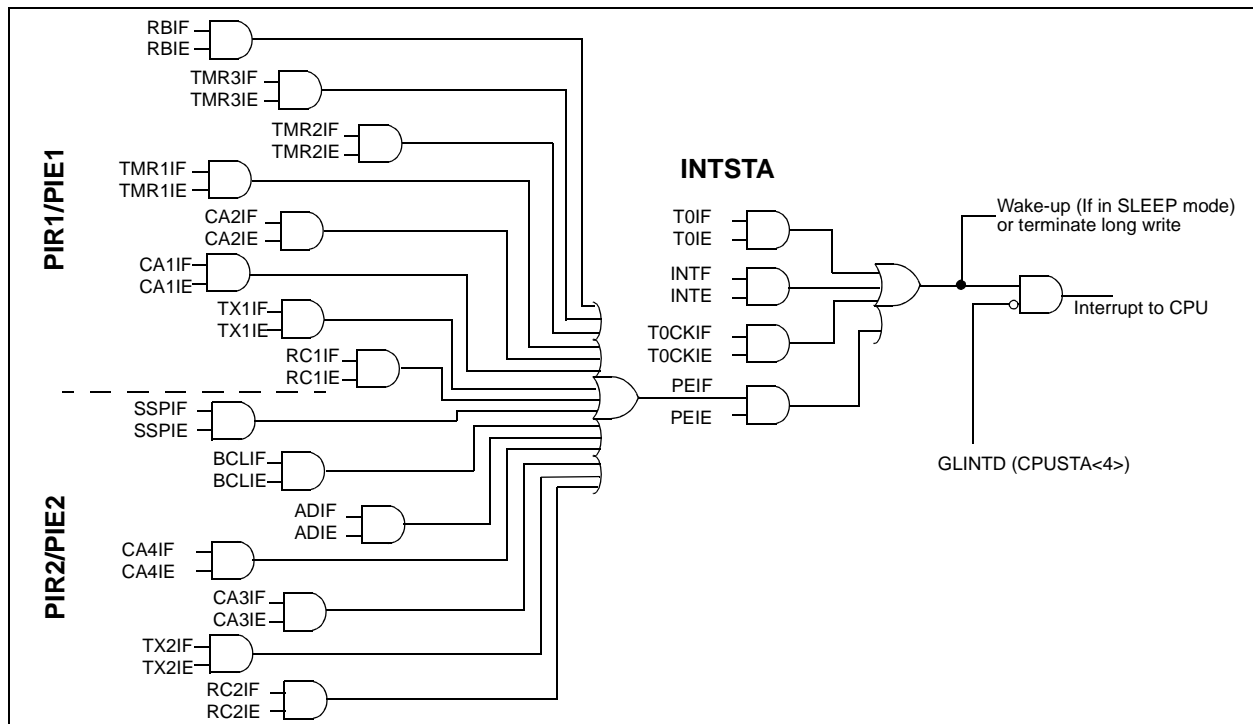

PIC17C7XX

6.1 Interrupt Status Register (INTSTA)

The Interrupt Status/Control register (INTSTA) contains the flag and enable bits for non-peripheral interrupts.

The PEIF bit is a read only, bit wise OR of all the peripheral flag bits in the PIR registers (Figure 6-4 and Figure 6-5).

Note: All interrupt flag bits get set by their specified condition, even if the corresponding interrupt enable bit is clear (interrupt disabled), or the GLINTD bit is set (all interrupts disabled).

Care should be taken when clearing any of the INTSTA register enable bits when interrupts are enabled (GLINTD is clear). If any of the INTSTA flag bits (TOIF, INTF, T0CKIF, or PEIF) are set in the same instruction cycle as the corresponding interrupt enable bit is cleared, the device will vector to the RESET address (0x00).

Prior to disabling any of the INTSTA enable bits, the GLINTD bit should be set (disabled).

REGISTER 6-1: INTSTA REGISTER (ADDRESS: 07h, UNBANKED)

	R-0	R/W-0	R/W-0	R/W-0	R/W-0	R/W-0	R/W-0	R/W-0
	PEIF	T0CKIF	TOIF	INTF	PEIE	T0CKIE	TOIE	INTE
bit 7								bit 0

- bit 7 **PEIF:** Peripheral Interrupt Flag bit
This bit is the OR of all peripheral interrupt flag bits AND'ed with their corresponding enable bits. The interrupt logic forces program execution to address (20h) when a peripheral interrupt is pending.
1 = A peripheral interrupt is pending
0 = No peripheral interrupt is pending
- bit 6 **T0CKIF:** External Interrupt on T0CKI Pin Flag bit
This bit is cleared by hardware, when the interrupt logic forces program execution to address (18h).
1 = The software specified edge occurred on the RA1/T0CKI pin
0 = The software specified edge did not occur on the RA1/T0CKI pin
- bit 5 **TOIF:** TMR0 Overflow Interrupt Flag bit
This bit is cleared by hardware, when the interrupt logic forces program execution to address (10h).
1 = TMR0 overflowed
0 = TMR0 did not overflow
- bit 4 **INTF:** External Interrupt on INT Pin Flag bit
This bit is cleared by hardware, when the interrupt logic forces program execution to address (08h).
1 = The software specified edge occurred on the RA0/INT pin
0 = The software specified edge did not occur on the RA0/INT pin
- bit 3 **PEIE:** Peripheral Interrupt Enable bit
This bit acts as a global enable bit for the peripheral interrupts that have their corresponding enable bits set.
1 = Enable peripheral interrupts
0 = Disable peripheral interrupts
- bit 2 **T0CKIE:** External Interrupt on T0CKI Pin Enable bit
1 = Enable software specified edge interrupt on the RA1/T0CKI pin
0 = Disable interrupt on the RA1/T0CKI pin
- bit 1 **TOIE:** TMR0 Overflow Interrupt Enable bit
1 = Enable TMR0 overflow interrupt
0 = Disable TMR0 overflow interrupt
- bit 0 **INTE:** External Interrupt on RA0/INT Pin Enable bit
1 = Enable software specified edge interrupt on the RA0/INT pin
0 = Disable software specified edge interrupt on the RA0/INT pin

Legend:
 R = Readable bit W = Writable bit U = Unimplemented bit, read as '0'
 - n = Value at POR Reset '1' = Bit is set '0' = Bit is cleared x = Bit is unknown

6.2 Peripheral Interrupt Enable Register1 (PIE1) and Register2 (PIE2)

These registers contains the individual enable bits for the peripheral interrupts.

REGISTER 6-2: PIE1 REGISTER (ADDRESS: 17h, BANK 1)

R/W-0	R/W-0	R/W-0	R/W-0	R/W-0	R/W-0	R/W-0	R/W-0
RBIE	TMR3IE	TMR2IE	TMR1IE	CA2IE	CA1IE	TX1IE	RC1IE
bit 7						bit 0	

- bit 7 **RBIE:** PORTB Interrupt-on-Change Enable bit
1 = Enable PORTB interrupt-on-change
0 = Disable PORTB interrupt-on-change
- bit 6 **TMR3IE:** TMR3 Interrupt Enable bit
1 = Enable TMR3 interrupt
0 = Disable TMR3 interrupt
- bit 5 **TMR2IE:** TMR2 Interrupt Enable bit
1 = Enable TMR2 interrupt
0 = Disable TMR2 interrupt
- bit 4 **TMR1IE:** TMR1 Interrupt Enable bit
1 = Enable TMR1 interrupt
0 = Disable TMR1 interrupt
- bit 3 **CA2IE:** Capture2 Interrupt Enable bit
1 = Enable Capture2 interrupt
0 = Disable Capture2 interrupt
- bit 2 **CA1IE:** Capture1 Interrupt Enable bit
1 = Enable Capture1 interrupt
0 = Disable Capture1 interrupt
- bit 1 **TX1IE:** USART1 Transmit Interrupt Enable bit
1 = Enable USART1 Transmit buffer empty interrupt
0 = Disable USART1 Transmit buffer empty interrupt
- bit 0 **RC1IE:** USART1 Receive Interrupt Enable bit
1 = Enable USART1 Receive buffer full interrupt
0 = Disable USART1 Receive buffer full interrupt

Legend:

R = Readable bit	W = Writable bit	U = Unimplemented bit, read as '0'
- n = Value at POR Reset	'1' = Bit is set	'0' = Bit is cleared x = Bit is unknown

PIC17C7XX

REGISTER 6-3: PIE2 REGISTER (ADDRESS: 11h, BANK 4)

R/W-0	R/W-0	R/W-0	U-0	R/W-0	R/W-0	R/W-0	R/W-0
SSPIE	BCLIE	ADIE	—	CA4IE	CA3IE	TX2IE	RC2IE

bit 7 bit 0

- bit 7 **SSPIE:** Synchronous Serial Port Interrupt Enable bit
1 = Enable SSP interrupt
0 = Disable SSP interrupt
- bit 6 **BCLIE:** Bus Collision Interrupt Enable bit
1 = Enable bus collision interrupt
0 = Disable bus collision interrupt
- bit 5 **ADIE:** A/D Module Interrupt Enable bit
1 = Enable A/D module interrupt
0 = Disable A/D module interrupt
- bit 4 **Unimplemented:** Read as '0'
- bit 3 **CA4IE:** Capture4 Interrupt Enable bit
1 = Enable Capture4 interrupt
0 = Disable Capture4 interrupt
- bit 2 **CA3IE:** Capture3 Interrupt Enable bit
1 = Enable Capture3 interrupt
0 = Disable Capture3 interrupt
- bit 1 **TX2IE:** USART2 Transmit Interrupt Enable bit
1 = Enable USART2 Transmit buffer empty interrupt
0 = Disable USART2 Transmit buffer empty interrupt
- bit 0 **RC2IE:** USART2 Receive Interrupt Enable bit
1 = Enable USART2 Receive buffer full interrupt
0 = Disable USART2 Receive buffer full interrupt

Legend:

R = Readable bit W = Writable bit U = Unimplemented bit, read as '0'
- n = Value at POR Reset '1' = Bit is set '0' = Bit is cleared x = Bit is unknown

6.3 Peripheral Interrupt Request Register1 (PIR1) and Register2 (PIR2)

These registers contains the individual flag bits for the peripheral interrupts.

Note: These bits will be set by the specified condition, even if the corresponding interrupt enable bit is cleared (interrupt disabled), or the GLINTD bit is set (all interrupts disabled). Before enabling an interrupt, the user may wish to clear the interrupt flag to ensure that the program does not immediately branch to the peripheral Interrupt Service Routine.

REGISTER 6-4: PIR1 REGISTER (ADDRESS: 16h, BANK 1)

R/W-x	R/W-0	R/W-0	R/W-0	R/W-0	R/W-0	R-1	R-0
RBIF	TMR3IF	TMR2IF	TMR1IF	CA2IF	CA1IF	TX1IF	RC1IF
bit 7						bit 0	

- bit 7 **RBIF:** PORTB Interrupt-on-Change Flag bit
 1 = One of the PORTB inputs changed (software must end the mismatch condition)
 0 = None of the PORTB inputs have changed

- bit 6 **TMR3IF:** TMR3 Interrupt Flag bit
If Capture1 is enabled (CA1/PR3 = 1):
 1 = TMR3 overflowed
 0 = TMR3 did not overflow
If Capture1 is disabled (CA1/PR3 = 0):
 1 = TMR3 value has rolled over to 0000h from equalling the period register (PR3H:PR3L) value
 0 = TMR3 value has not rolled over to 0000h from equalling the period register (PR3H:PR3L) value

- bit 5 **TMR2IF:** TMR2 Interrupt Flag bit
 1 = TMR2 value has rolled over to 0000h from equalling the period register (PR2) value
 0 = TMR2 value has not rolled over to 0000h from equalling the period register (PR2) value

- bit 4 **TMR1IF:** TMR1 Interrupt Flag bit
If TMR1 is in 8-bit mode (T16 = 0):
 1 = TMR1 value has rolled over to 0000h from equalling the period register (PR1) value
 0 = TMR1 value has not rolled over to 0000h from equalling the period register (PR1) value
If Timer1 is in 16-bit mode (T16 = 1):
 1 = TMR2:TMR1 value has rolled over to 0000h from equalling the period register (PR2:PR1) value
 0 = TMR2:TMR1 value has not rolled over to 0000h from equalling the period register (PR2:PR1) value

- bit 3 **CA2IF:** Capture2 Interrupt Flag bit
 1 = Capture event occurred on RB1/CAP2 pin
 0 = Capture event did not occur on RB1/CAP2 pin

- bit 2 **CA1IF:** Capture1 Interrupt Flag bit
 1 = Capture event occurred on RB0/CAP1 pin
 0 = Capture event did not occur on RB0/CAP1 pin

- bit 1 **TX1IF:** USART1 Transmit Interrupt Flag bit (state controlled by hardware)
 1 = USART1 Transmit buffer is empty
 0 = USART1 Transmit buffer is full

- bit 0 **RC1IF:** USART1 Receive Interrupt Flag bit (state controlled by hardware)
 1 = USART1 Receive buffer is full
 0 = USART1 Receive buffer is empty

Legend:

R = Readable bit	W = Writable bit	U = Unimplemented bit, read as '0'
- n = Value at POR Reset	'1' = Bit is set	'0' = Bit is cleared
		x = Bit is unknown

PIC17C7XX

REGISTER 6-5: PIR2 REGISTER (ADDRESS: 10h, BANK 4)

R/W-0	R/W-0	R/W-0	U-0	R/W-0	R/W-0	R-1	R-0
SSPIF	BCLIF	ADIF	—	CA4IF	CA3IF	TX2IF	RC2IF

bit 7

bit 0

- bit 7 **SSPIF**: Synchronous Serial Port (SSP) Interrupt Flag bit
 1 = The SSP interrupt condition has occurred and must be cleared in software before returning from the Interrupt Service Routine. The conditions that will set this bit are:
SPI:
 A transmission/reception has taken place.
I²C Slave/Master:
 A transmission/reception has taken place.
I²C Master:
 The initiated START condition was completed by the SSP module.
 The initiated STOP condition was completed by the SSP module.
 The initiated Restart condition was completed by the SSP module.
 The initiated Acknowledge condition was completed by the SSP module.
 A START condition occurred while the SSP module was idle (Multi-master system).
 A STOP condition occurred while the SSP module was idle (Multi-master system).
 0 = An SSP interrupt condition has NOT occurred
- bit 6 **BCLIF**: Bus Collision Interrupt Flag bit
 1 = A bus collision has occurred in the SSP, when configured for I²C Master mode
 0 = No bus collision has occurred
- bit 5 **ADIF**: A/D Module Interrupt Flag bit
 1 = An A/D conversion is complete
 0 = An A/D conversion is not complete
- bit 4 **Unimplemented**: Read as '0'
- bit 3 **CA4IF**: Capture4 Interrupt Flag bit
 1 = Capture event occurred on RE3/CAP4 pin
 0 = Capture event did not occur on RE3/CAP4 pin
- bit 2 **CA3IF**: Capture3 Interrupt Flag bit
 1 = Capture event occurred on RG4/CAP3 pin
 0 = Capture event did not occur on RG4/CAP3 pin
- bit 1 **TX2IF**: USART2 Transmit Interrupt Flag bit (state controlled by hardware)
 1 = USART2 Transmit buffer is empty
 0 = USART2 Transmit buffer is full
- bit 0 **RC2IF**: USART2 Receive Interrupt Flag bit (state controlled by hardware)
 1 = USART2 Receive buffer is full
 0 = USART2 Receive buffer is empty

Legend:

R = Readable bit	W = Writable bit	U = Unimplemented bit, read as '0'
- n = Value at POR Reset	'1' = Bit is set	'0' = Bit is cleared x = Bit is unknown

6.4 Interrupt Operation

Global Interrupt Disable bit, GLINTD (CPUSTA<4>), enables all unmasked interrupts (if clear), or disables all interrupts (if set). Individual interrupts can be disabled through their corresponding enable bits in the INTSTA register. Peripheral interrupts need either the global peripheral enable PEIE bit disabled, or the specific peripheral enable bit disabled. Disabling the peripherals via the global peripheral enable bit, disables all peripheral interrupts. GLINTD is set on RESET (interrupts disabled).

The RETFIE instruction clears the GLINTD bit while forcing the Program Counter (PC) to the value loaded at the Top-of-Stack.

When an interrupt is responded to, the GLINTD bit is automatically set to disable any further interrupt, the return address is pushed onto the stack and the PC is loaded with the interrupt vector. There are four interrupt vectors which help reduce interrupt latency.

The peripheral interrupt vector has multiple interrupt sources. Once in the peripheral Interrupt Service Routine, the source(s) of the interrupt can be determined by polling the interrupt flag bits. The peripheral interrupt flag bit(s) must be cleared in software before re-enabling interrupts to avoid continuous interrupts.

The PIC17C7XX devices have four interrupt vectors. These vectors and their hardware priority are shown in Table 6-1. If two enabled interrupts occur “at the same time”, the interrupt of the highest priority will be serviced first. This means that the vector address of that interrupt will be loaded into the program counter (PC).

TABLE 6-1: INTERRUPT VECTORS/ PRIORITIES

Address	Vector	Priority
0008h	External Interrupt on RA0/INT pin (INTF)	1 (Highest)
0010h	TMR0 Overflow Interrupt (TOIF)	2
0018h	External Interrupt on T0CKI (T0CKIF)	3
0020h	Peripherals (PEIF)	4 (Lowest)

Note 1: Individual interrupt flag bits are set, regardless of the status of their corresponding mask bit or the GLINTD bit.

2: Before disabling any of the INTSTA enable bits, the GLINTD bit should be set (disabled).

6.5 RA0/INT Interrupt

The external interrupt on the RA0/INT pin is edge triggered. Either the rising edge if the INTEDG bit (T0STA<7>) is set, or the falling edge if the INTEDG bit is clear. When a valid edge appears on the RA0/INT pin, the INTF bit (INTSTA<4>) is set. This interrupt can be disabled by clearing the INTE control bit (INTSTA<0>). The INT interrupt can wake the processor from SLEEP. See Section 17.4 for details on SLEEP operation.

6.6 T0CKI Interrupt

The external interrupt on the RA1/T0CKI pin is edge triggered. Either the rising edge if the T0SE bit (T0STA<6>) is set, or the falling edge if the T0SE bit is clear. When a valid edge appears on the RA1/T0CKI pin, the T0CKIF bit (INTSTA<6>) is set. This interrupt can be disabled by clearing the T0CKIE control bit (INTSTA<2>). The T0CKI interrupt can wake up the processor from SLEEP. See Section 17.4 for details on SLEEP operation.

6.7 Peripheral Interrupt

The peripheral interrupt flag indicates that at least one of the peripheral interrupts occurred (PEIF is set). The PEIF bit is a read only bit and is a bit wise OR of all the flag bits in the PIR registers AND'd with the corresponding enable bits in the PIE registers. Some of the peripheral interrupts can wake the processor from SLEEP. See Section 17.4 for details on SLEEP operation.

6.8 Context Saving During Interrupts

During an interrupt, only the returned PC value is saved on the stack. Typically, users may wish to save key registers during an interrupt; e.g. WREG, ALUSTA and the BSR registers. This requires implementation in software.

Example 6-2 shows the saving and restoring of information for an Interrupt Service Routine. This is for a simple interrupt scheme, where only one interrupt may occur at a time (no interrupt nesting). The SFRs are stored in the non-banked GPR area.

Example 6-2 shows the saving and restoring of information for a more complex Interrupt Service Routine. This is useful where nesting of interrupts is required. A maximum of 6 levels can be done by this example. The BSR is stored in the non-banked GPR area, while the other registers would be stored in a particular bank. Therefore, 6 saves may be done with this routine (since there are 6 non-banked GPR registers). These routines require a dedicated indirect addressing register, FSR0, to be selected for this.

The PUSH and POP code segments could either be in each Interrupt Service Routine, or could be subroutines that were called. Depending on the application, other registers may also need to be saved.

PIC17C7XX

FIGURE 6-2: INT PIN/T0CKI PIN INTERRUPT TIMING

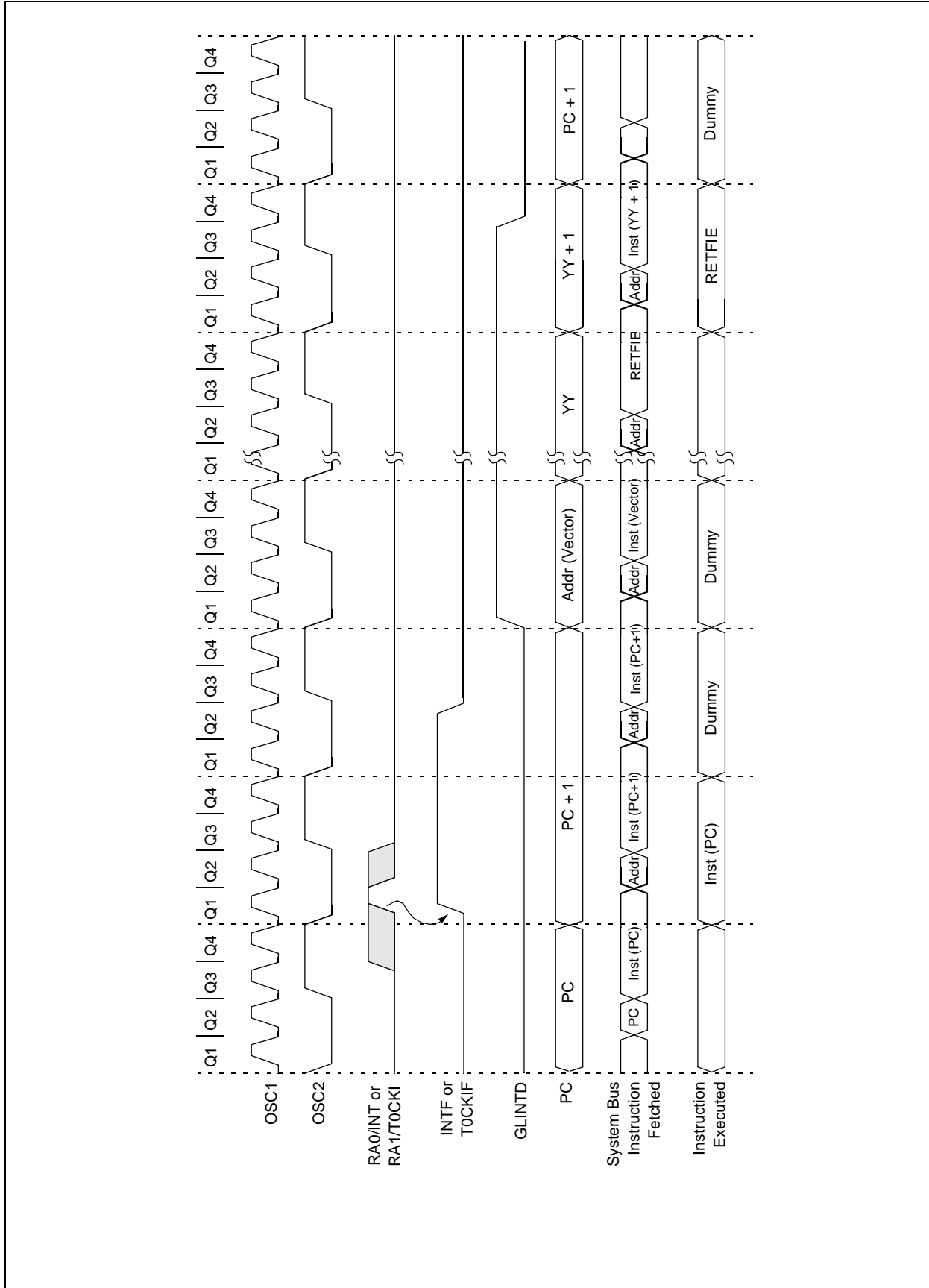

EXAMPLE 6-1: SAVING STATUS AND WREG IN RAM (SIMPLE)

```

; The addresses that are used to store the CPUSTA and WREG values must be in the data memory
; address range of 1Ah - 1Fh. Up to 6 locations can be saved and restored using the MOVFP
; instruction. This instruction neither affects the status bits, nor corrupts the WREG register.
;
UNBANK1      EQU    0x01A      ; Address for 1st location to save
UNBANK2      EQU    0x01B      ; Address for 2nd location to save
UNBANK3      EQU    0x01C      ; Address for 3rd location to save
UNBANK4      EQU    0x01D      ; Address for 4th location to save
UNBANK5      EQU    0x01E      ; Address for 5th location to save
;                                     (Label Not used in program)
UNBANK6      EQU    0x01F      ; Address for 6th location to save
;                                     (Label Not used in program)
;
;                                     ; At Interrupt Vector Address
PUSH         :
MOVFP       ALUSTA, UNBANK1      ; Push ALUSTA value
MOVFP       BSR, UNBANK2        ; Push BSR value
MOVFP       WREG, UNBANK3       ; Push WREG value
MOVFP       PCLATH, UNBANK4     ; Push PCLATH value
;
;                                     ; Interrupt Service Routine (ISR) code
;
POP         MOVFP       UNBANK4, PCLATH ; Restore PCLATH value
MOVFP       UNBANK3, WREG       ; Restore WREG value
MOVFP       UNBANK2, BSR       ; Restore BSR value
MOVFP       UNBANK1, ALUSTA     ; Restore ALUSTA value
;
RETDFIE     ; Return from interrupt (enable interrupts)

```

PIC17C7XX

EXAMPLE 6-2: SAVING STATUS AND WREG IN RAM (NESTED)

```
; The addresses that are used to store the CPUSTA and WREG values must be in the data memory
; address range of 1Ah - 1Fh. Up to 6 locations can be saved and restored using the MOVFP
; instruction. This instruction neither affects the status bits, nor corrupts the WREG register.
; This routine uses the FRS0, so it controls the FS1 and FS0 bits in the ALUSTA register.
;
Nobank_FSR    EQU    0x40
Bank_FSR     EQU    0x41
ALU_Temp     EQU    0x42
WREG_TEMP    EQU    0x43
BSR_S1      EQU    0x01A    ; 1st location to save BSR
BSR_S2      EQU    0x01B    ; 2nd location to save BSR (Label Not used in program)
BSR_S3      EQU    0x01C    ; 3rd location to save BSR (Label Not used in program)
BSR_S4      EQU    0x01D    ; 4th location to save BSR (Label Not used in program)
BSR_S5      EQU    0x01E    ; 5th location to save BSR (Label Not used in program)
BSR_S6      EQU    0x01F    ; 6th location to save BSR (Label Not used in program)
;
INITIALIZATION
    CALL    CLEAR_RAM    ; Must Clear all Data RAM
;
INIT_POINTERS    ; Must Initialize the pointers for POP and PUSH
    CLRF   BSR, F    ; Set All banks to 0
    CLRF   ALUSTA, F    ; FSR0 post increment
    BSF   ALUSTA, FS1
    CLRF   WREG, F    ; Clear WREG
    MOVLW BSR_S1    ; Load FSR0 with 1st address to save BSR
    MOVWF FSR0
    MOVWF Nobank_FSR
    MOVLW 0x20
    MOVWF Bank_FSR
    :
    :    ; Your code
    :
    :    ; At Interrupt Vector Address
PUSH    BSF   ALUSTA, FS0    ; FSR0 has auto-increment, does not affect status bits
        BCF   ALUSTA, FS1    ; does not affect status bits
        MOVFP BSR, INDF0    ; No Status bits are affected
        CLRF   BSR, F    ; Peripheral and Data RAM Bank 0 No Status bits are affected
        MOVFP ALUSTA, ALU_Temp
        MOVFP FSR0, Nobank_FSR    ; Save the FSR for BSR values
        MOVFP WREG, WREG_TEMP
        MOVFP Bank_FSR, FSR0    ; Restore FSR value for other values
        MOVFP ALU_Temp, INDF0    ; Push ALUSTA value
        MOVFP WREG_TEMP, INDF0    ; Push WREG value
        MOVFP PCLATH, INDF0    ; Push PCLATH value
        MOVFP FSR0, Bank_FSR    ; Restore FSR value for other values
        MOVFP Nobank_FSR, FSR0
        ;
        :    ; Interrupt Service Routine (ISR) code
        ;
POP     CLRF   ALUSTA, F    ; FSR0 has auto-decrement, does not affect status bits
        MOVFP Bank_FSR, FSR0    ; Restore FSR value for other values
        DECF   FSR0, F
        MOVFP INDF0, PCLATH    ; Pop PCLATH value
        MOVFP INDF0, WREG    ; Pop WREG value
        BSF   ALUSTA, FS1    ; FSR0 does not change
        MOVFP INDF0, ALU_Temp    ; Pop ALUSTA value
        MOVFP FSR0, Bank_FSR    ; Restore FSR value for other values
        DECF   Nobank_FSR, F
        MOVFP Nobank_FSR, FSR0    ; Save the FSR for BSR values
        MOVFP ALU_Temp, ALUSTA
        MOVFP INDF0, BSR    ; No Status bits are affected
;
    RETFIE    ; Return from interrupt (enable interrupts)
```

7.0 MEMORY ORGANIZATION

There are two memory blocks in the PIC17C7XX; program memory and data memory. Each block has its own bus, so that access to each block can occur during the same oscillator cycle.

The data memory can further be broken down into General Purpose RAM and the Special Function Registers (SFRs). The operation of the SFRs that control the “core” are described here. The SFRs used to control the peripheral modules are described in the section discussing each individual peripheral module.

7.1 Program Memory Organization

PIC17C7XX devices have a 16-bit program counter capable of addressing a 64K x 16 program memory space. The RESET vector is at 0000h and the interrupt vectors are at 0008h, 0010h, 0018h, and 0020h (Figure 7-1).

7.1.1 PROGRAM MEMORY OPERATION

The PIC17C7XX can operate in one of four possible program memory configurations. The configuration is selected by configuration bits. The possible modes are:

- Microprocessor
- Microcontroller
- Extended Microcontroller
- Protected Microcontroller

The **Microcontroller** and **Protected Microcontroller** modes only allow internal execution. Any access beyond the program memory reads unknown data. The Protected Microcontroller mode also enables the code protection feature.

The **Extended Microcontroller** mode accesses both the internal program memory, as well as external program memory. Execution automatically switches between internal and external memory. The 16-bits of address allow a program memory range of 64K-words.

The **Microprocessor** mode only accesses the external program memory. The on-chip program memory is ignored. The 16-bits of address allow a program memory range of 64K-words. Microprocessor mode is the default mode of an unprogrammed device.

The different modes allow different access to the configuration bits, test memory and boot ROM. Table 7-1 lists which modes can access which areas in memory. Test Memory and Boot Memory are not required for normal operation of the device. Care should be taken to ensure that no unintended branches occur to these areas.

FIGURE 7-1: PROGRAM MEMORY MAP AND STACK

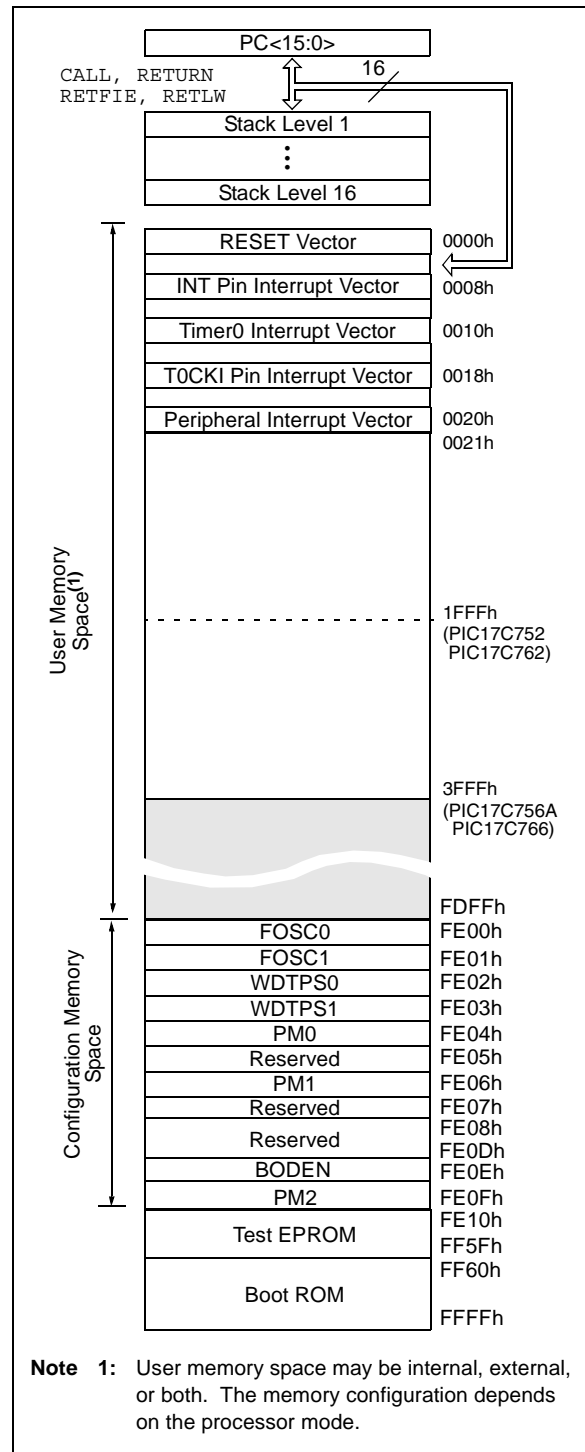

PIC17C7XX

TABLE 7-1: MODE MEMORY ACCESS

Operating Mode	Internal Program Memory	Configuration Bits, Test Memory, Boot ROM
Microprocessor	No Access	No Access
Microcontroller	Access	Access
Extended Microcontroller	Access	No Access
Protected Microcontroller	Access	Access

The PIC17C7XX can operate in modes where the program memory is off-chip. They are the Microprocessor and Extended Microcontroller modes. The Microprocessor mode is the default for an unprogrammed device.

Regardless of the processor mode, data memory is always on-chip.

FIGURE 7-2: MEMORY MAP IN DIFFERENT MODES

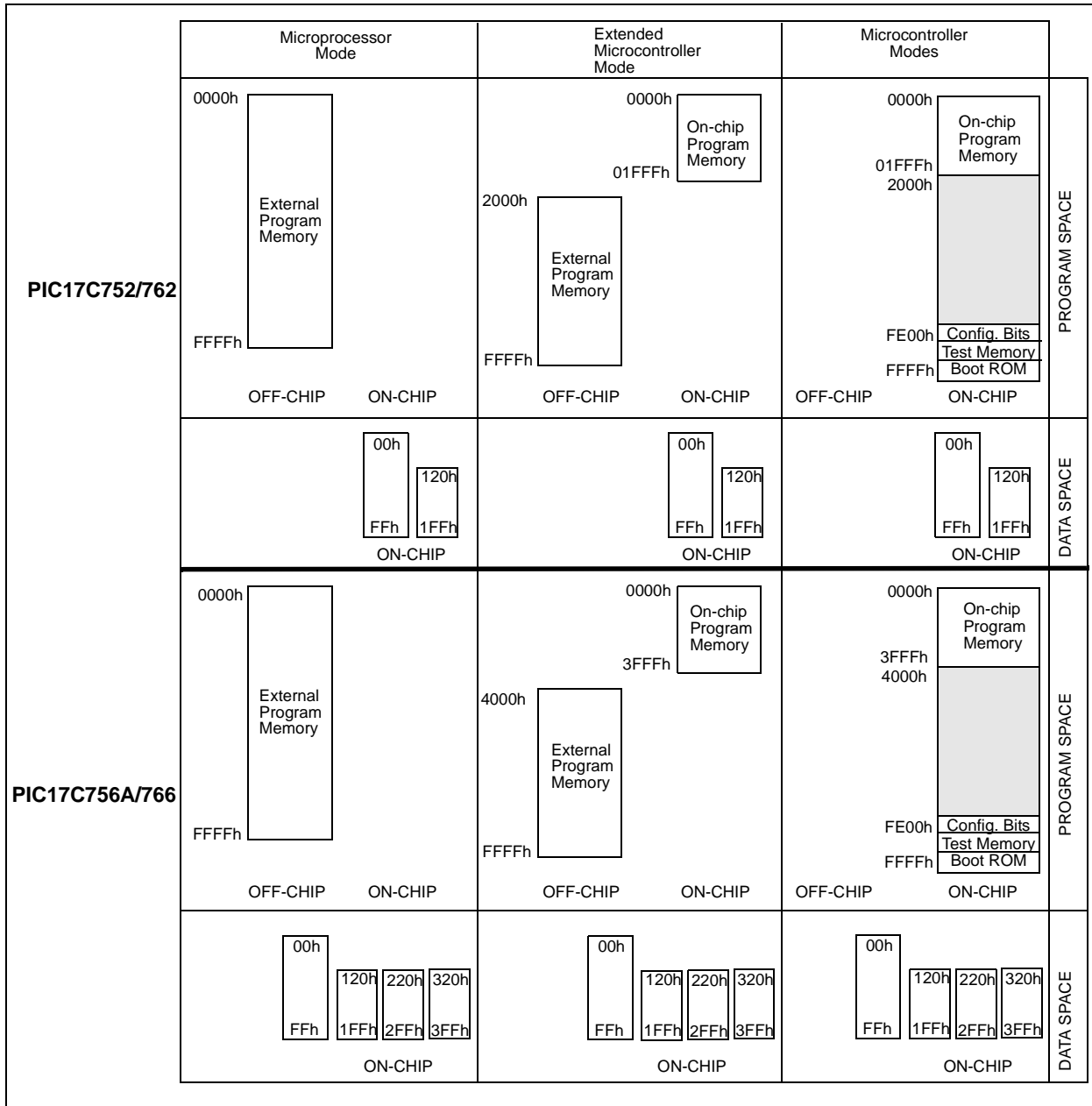

7.1.2 EXTERNAL MEMORY INTERFACE

When either Microprocessor or Extended Microcontroller mode is selected, PORTC, PORTD and PORTE are configured as the system bus. PORTC and PORTD are the multiplexed address/data bus and PORTE<2:0> is for the control signals. External components are needed to demultiplex the address and data. This can be done as shown in Figure 7-4. The waveforms of address and data are shown in Figure 7-3. For complete timings, please refer to the electrical specification section.

FIGURE 7-3: EXTERNAL PROGRAM MEMORY ACCESS WAVEFORMS

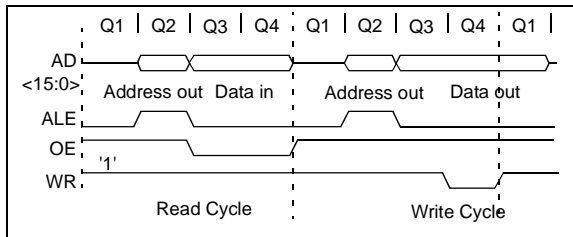

The system bus requires that there is no bus conflict (minimal leakage), so the output value (address) will be capacitively held at the desired value.

As the speed of the processor increases, external EPROM memory with faster access time must be used. Table 7-2 lists external memory speed requirements for a given PIC17C7XX device frequency.

In Extended Microcontroller mode, when the device is executing out of internal memory, the control signals will continue to be active. That is, they indicate the action that is occurring in the internal memory. The external memory access is ignored.

The following selection is for use with Microchip EPROMs. For interfacing to other manufacturers memory, please refer to the electrical specifications of the desired PIC17C7XX device, as well as the desired memory device to ensure compatibility.

TABLE 7-2: EPROM MEMORY ACCESS TIME ORDERING SUFFIX

PIC17C7XX Oscillator Frequency	Instruction Cycle Time (Tcy)	EPROM Suffix
8 MHz	500 ns	-25
16 MHz	250 ns	-15
20 MHz	200 ns	-10
25 MHz	160 ns	-70

Note: The access times for this requires the use of fast SRAMs.

The electrical specifications now include timing specifications for the memory interface with PIC17LCXXX devices. These specifications reflect the capability of the device by characterization. Please validate your design with these timings.

FIGURE 7-4: TYPICAL EXTERNAL PROGRAM MEMORY CONNECTION DIAGRAM

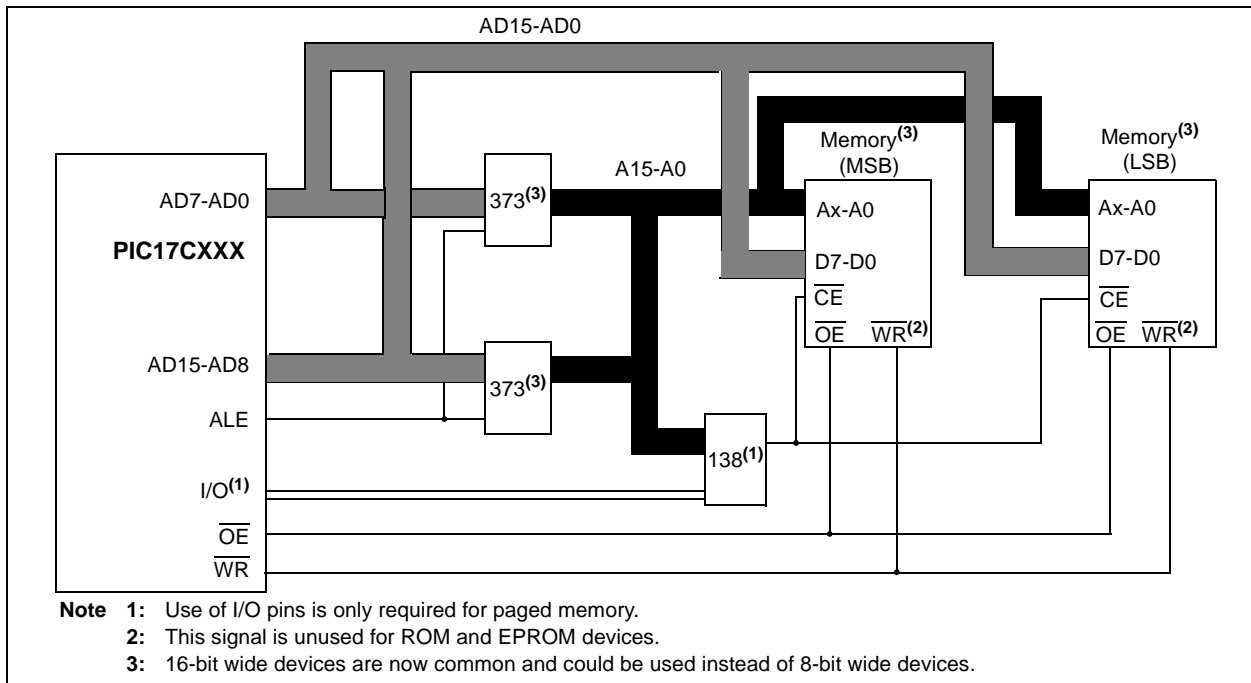

PIC17C7XX

7.2 Data Memory Organization

Data memory is partitioned into two areas. The first is the General Purpose Registers (GPR) area, and the second is the Special Function Registers (SFR) area. The SFRs control and provide status of device operation.

Portions of data memory are banked, this occurs in both areas. The GPR area is banked to allow greater than 232 bytes of general purpose RAM.

Banking requires the use of control bits for bank selection. These control bits are located in the Bank Select Register (BSR). If an access is made to the unbanked region, the BSR bits are ignored. Figure 7-5 shows the data memory map organization.

Instructions `MOVVF` and `MOVFP` provide the means to move values from the peripheral area (“P”) to any location in the register file (“F”), and vice-versa. The definition of the “P” range is from 0h to 1Fh, while the “F” range is 0h to FFh. The “P” range has six more locations than peripheral registers, which can be used as General Purpose Registers. This can be useful in some applications where variables need to be copied to other locations in the general purpose RAM (such as saving status information during an interrupt).

The entire data memory can be accessed either directly, or indirectly (through file select registers FSR0 and FSR1) (see Section 7.4). Indirect addressing uses the appropriate control bits of the BSR for access into the banked areas of data memory. The BSR is explained in greater detail in Section 7.8.

7.2.1 GENERAL PURPOSE REGISTER (GPR)

All devices have some amount of GPR area. The GPRs are 8-bits wide. When the GPR area is greater than 232, it must be banked to allow access to the additional memory space.

All the PIC17C7XX devices have banked memory in the GPR area. To facilitate switching between these banks, the `MOVLR bank` instruction has been added to the instruction set. GPRs are not initialized by a Power-on Reset and are unchanged on all other RESETS.

7.2.2 SPECIAL FUNCTION REGISTERS (SFR)

The SFRs are used by the CPU and peripheral functions to control the operation of the device (Figure 7-5). These registers are static RAM.

The SFRs can be classified into two sets, those associated with the “core” function and those related to the peripheral functions. Those registers related to the “core” are described here, while those related to a peripheral feature are described in the section for each peripheral feature.

The peripheral registers are in the banked portion of memory, while the core registers are in the unbanked region. To facilitate switching between the peripheral banks, the `MOVLB bank` instruction has been provided.

FIGURE 7-5: PIC17C7XX REGISTER FILE MAP

Addr	Unbanked								
00h	INDF0								
01h	FSR0								
02h	PCL								
03h	PCLATH								
04h	ALUSTA								
05h	T0STA								
06h	CPUSTA								
07h	INTSTA								
08h	INDF1								
09h	FSR1								
0Ah	WREG								
0Bh	TMR0L								
0Ch	TMR0H								
0Dh	TBLPTRL								
0Eh	TBLPTRH								
0Fh	BSR								
	Bank 0	Bank 1⁽¹⁾	Bank 2⁽¹⁾	Bank 3⁽¹⁾	Bank 4⁽¹⁾	Bank 5⁽¹⁾	Bank 6⁽¹⁾	Bank 7⁽¹⁾	Bank 8^(1,4)
10h	PORTA	DDRC	TMR1	PW1DCL	PIR2	DDRF	SSPADD	PW3DCL	DDRH
11h	DDRB	PORTC	TMR2	PW2DCL	PIE2	PORTF	SSPCON1	PW3DCH	PORTH
12h	PORTB	DDRD	TMR3L	PW1DCH	—	DDRG	SSPCON2	CA3L	DDRJ
13h	RCSTA1	PORTD	TMR3H	PW2DCH	RCSTA2	PORTG	SSPSTAT	CA3H	PORTJ
14h	RCREG1	DDRE	PR1	CA2L	RCREG2	ADCON0	SSPBUF	CA4L	—
15h	TXSTA1	PORTE	PR2	CA2H	TXSTA2	ADCON1	—	CA4H	—
16h	TXREG1	PIR1	PR3L/CA1L	TCON1	TXREG2	ADRESL	—	TCON3	—
17h	SPBRG1	PIE1	PR3H/CA1H	TCON2	SPBRG2	ADRESH	—	—	—
	Unbanked								
18h	PRODL								
19h	PRODH								
1Ah	General Purpose RAM								
1Fh									
	Bank 0⁽²⁾	Bank 1⁽²⁾	Bank 2⁽²⁾	Bank 3^(2,3)					
20h	General Purpose RAM	General Purpose RAM	General Purpose RAM	General Purpose RAM					
FFh									

- Note 1:** SFR file locations 10h - 17h are banked. The lower nibble of the BSR specifies the bank. All unbanked SFRs ignore the Bank Select Register (BSR) bits.
- 2:** General Purpose Registers (GPR) locations 20h - FFh, 120h - 1FFh, 220h - 2FFh, and 320h - 3FFh are banked. The upper nibble of the BSR specifies this bank. All other GPRs ignore the Bank Select Register (BSR) bits.
- 3:** RAM bank 3 is not implemented on the PIC17C752 and the PIC17C762. Reading any unimplemented register reads '0's.
- 4:** Bank 8 is only implemented on the PIC17C76X devices.

PIC17C7XX

TABLE 7-3: SPECIAL FUNCTION REGISTERS

Address	Name	Bit 7	Bit 6	Bit 5	Bit 4	Bit 3	Bit 2	Bit 1	Bit 0	Value on POR, BOR	MCLR, WDT
Unbanked											
00h	INDF0	Uses contents of FSR0 to address Data Memory (not a physical register)								----	----
01h	FSR0	Indirect Data Memory Address Pointer 0								xxxx	xxxx
02h	PCL	Low order 8-bits of PC								0000	0000
03h ⁽¹⁾	PCLATH	Holding Register for upper 8-bits of PC								0000	0000
04h	ALUSTA	FS3	FS2	FS1	FS0	OV	Z	DC	C	1111	xxxx
05h	TOSTA	INTEDG	T0SE	T0CS	T0PS3	T0PS2	T0PS1	T0PS0	—	0000	000-
06h ⁽²⁾	CPUSTA	—	—	STKAV	GLINTD	\overline{TO}	\overline{PD}	\overline{POR}	\overline{BOR}	--11	11qq
07h	INTSTA	PEIF	T0CKIF	T0IF	INTF	PEIE	T0CKIE	T0IE	INTE	0000	0000
08h	INDF1	Uses contents of FSR1 to address Data Memory (not a physical register)								----	----
09h	FSR1	Indirect Data Memory Address Pointer 1								xxxx	xxxx
0Ah	WREG	Working Register								xxxx	xxxx
0Bh	TMR0L	TMR0 Register; Low Byte								xxxx	xxxx
0Ch	TMR0H	TMR0 Register; High Byte								xxxx	xxxx
0Dh	TBLPTRL	Low Byte of Program Memory Table Pointer								0000	0000
0Eh	TBLPTRH	High Byte of Program Memory Table Pointer								0000	0000
0Fh	BSR	Bank Select Register								0000	0000
Bank 0											
10h	PORTA ^(4,6)	RBPUP	—	RA5/TX1/CK1	RA4/RX1/DT1	RA3/SDI/SDA	RA2/SS/SCL	RA1/T0CKI	RA0/INT	0-xx	11xx
11h	DDRB	Data Direction Register for PORTB								1111	1111
12h	PORTB ⁽⁴⁾	RB7/SDO	RB6/SCK	RB5/TCLK3	RB4/TCLK12	RB3/PWM2	RB2/PWM1	RB1/CAP2	RB0/CAP1	xxxx	xxxx
13h	RCSTA1	SPEN	RX9	SREN	CREN	—	FERR	OERR	RX9D	0000	-00x
14h	RCREG1	Serial Port Receive Register								xxxx	xxxx
15h	TXSTA1	CSRC	TX9	TXEN	SYNC	—	—	TRMT	TX9D	0000	--1x
16h	TXREG1	Serial Port Transmit Register (for USART1)								xxxx	xxxx
17h	SPBRG1	Baud Rate Generator Register (for USART1)								0000	0000
Bank 1											
10h	DDRC ⁽⁵⁾	Data Direction Register for PORTC								1111	1111
11h	PORTC ^(4,5)	RC7/AD7	RC6/AD6	RC5/AD5	RC4/AD4	RC3/AD3	RC2/AD2	RC1/AD1	RC0/AD0	xxxx	xxxx
12h	DDRD ⁽⁵⁾	Data Direction Register for PORTD								1111	1111
13h	PORTD ^(4,5)	RD7/AD15	RD6/AD14	RD5/AD13	RD4/AD12	RD3/AD11	RD2/AD10	RD1/AD9	RD0/AD8	xxxx	xxxx
14h	DDRE ⁽⁵⁾	Data Direction Register for PORTE								----	1111
15h	PORTE ^(4,5)	—	—	—	—	RE3/CAP4	RE2/ \overline{WR}	RE1/ \overline{OE}	RE0/ALE	----	xxxx
16h	PIR1	RBIF	TMR3IF	TMR2IF	TMR1IF	CA2IF	CA1IF	TX1IF	RC1IF	x000	0010
17h	PIE1	RBIE	TMR3IE	TMR2IE	TMR1IE	CA2IE	CA1IE	TX1IE	RC1IE	0000	0000

Legend: x = unknown, u = unchanged, - = unimplemented, read as '0', q = value depends on condition.

Shaded cells are unimplemented, read as '0'.

- Note**
- 1: The upper byte of the program counter is not directly accessible. PCLATH is a holding register for PC<15:8> whose contents are updated from, or transferred to, the upper byte of the program counter.
 - 2: The \overline{TO} and \overline{PD} status bits in CPUSTA are not affected by a MCLR Reset.
 - 3: Bank 8 and associated registers are only implemented on the PIC17C76X devices.
 - 4: This is the value that will be in the port output latch.
 - 5: When the device is configured for Microprocessor or Extended Microcontroller mode, the operation of this port does not rely on these registers.
 - 6: On any device RESET, these pins are configured as inputs.

PIC17C7XX

TABLE 7-3: SPECIAL FUNCTION REGISTERS (CONTINUED)

Address	Name	Bit 7	Bit 6	Bit 5	Bit 4	Bit 3	Bit 2	Bit 1	Bit 0	Value on POR, BOR	MCLR, WDT
Bank 2											
10h	TMR1	Timer1's Register								xxxx xxxx	uuuu uuuu
11h	TMR2	Timer2's Register								xxxx xxxx	uuuu uuuu
12h	TMR3L	Timer3's Register; Low Byte								xxxx xxxx	uuuu uuuu
13h	TMR3H	Timer3's Register; High Byte								xxxx xxxx	uuuu uuuu
14h	PR1	Timer1's Period Register								xxxx xxxx	uuuu uuuu
15h	PR2	Timer2's Period Register								xxxx xxxx	uuuu uuuu
16h	PR3L/CA1L	Timer3's Period Register - Low Byte/Capture1 Register; Low Byte								xxxx xxxx	uuuu uuuu
17h	PR3H/CA1H	Timer3's Period Register - High Byte/Capture1 Register; High Byte								xxxx xxxx	uuuu uuuu
Bank 3											
10h	PW1DCL	DC1	DC0	—	—	—	—	—	—	xx-- ----	uu-- ----
11h	PW2DCL	DC1	DC0	TM2PW2	—	—	—	—	—	xx0- ----	uu0- ----
12h	PW1DCH	DC9	DC8	DC7	DC6	DC5	DC4	DC3	DC2	xxxx xxxx	uuuu uuuu
13h	PW2DCH	DC9	DC8	DC7	DC6	DC5	DC4	DC3	DC2	xxxx xxxx	uuuu uuuu
14h	CA2L	Capture2 Low Byte								xxxx xxxx	uuuu uuuu
15h	CA2H	Capture2 High Byte								xxxx xxxx	uuuu uuuu
16h	TCON1	CA2ED1	CA2ED0	CA1ED1	CA1ED0	T16	TMR3CS	TMR2CS	TMR1CS	0000 0000	0000 0000
17h	TCON2	CA2OVF	CA1OVF	PWM2ON	PWM1ON	CA1/PR3	TMR3ON	TMR2ON	TMR1ON	0000 0000	0000 0000
Bank 4											
10h	PIR2	SSPIF	BCLIF	ADIF	—	CA4IF	CA3IF	TX2IF	RC2IF	000- 0010	000- 0010
11h	PIE2	SSPIE	BCLIE	ADIE	—	CA4IE	CA3IE	TX2IE	RC2IE	000- 0000	000- 0000
12h	Unimplemented	—	—	—	—	—	—	—	—	---- ----	---- ----
13h	RCSTA2	SPEN	RX9	SREN	CREN	—	FERR	OERR	RX9D	0000 -00x	0000 -00u
14h	RCREG2	Serial Port Receive Register for USART2								xxxx xxxx	uuuu uuuu
15h	TXSTA2	CSRC	TX9	TXEN	SYNC	—	—	TRMT	TX9D	0000 --1x	0000 --1u
16h	TXREG2	Serial Port Transmit Register for USART2								xxxx xxxx	uuuu uuuu
17h	SPBRG2	Baud Rate Generator for USART2								0000 0000	0000 0000
Bank 5:											
10h	DDRF	Data Direction Register for PORTF								1111 1111	1111 1111
11h	PORTF ⁽⁴⁾	RF7/ AN11	RF6/ AN10	RF5/ AN9	RF4/ AN8	RF3/ AN7	RF2/ AN6	RF1/ AN5	RF0/ AN4	0000 0000	0000 0000
12h	DDRG	Data Direction Register for PORTG								1111 1111	1111 1111
13h	PORTG ⁽⁴⁾	RG7/ TX2/CK2	RG6/ RX2/DT2	RG5/ PWM3	RG4/ CAP3	RG3/ AN0	RG2/ AN1	RG1/ AN2	RG0/ AN3	xxxx 0000	uuuu 0000
14h	ADCON0	CHS3	CHS2	CHS1	CHS0	—	GO/DONE	—	ADON	0000 -0-0	0000 -0-0
15h	ADCON1	ADCS1	ADCS0	ADFM	—	PCFG3	PCFG2	PCFG1	PCFG0	000- 0000	000- 0000
16h	ADRESL	A/D Result Register Low Byte								xxxx xxxx	uuuu uuuu
17h	ADRESH	A/D Result Register High Byte								xxxx xxxx	uuuu uuuu

Legend: x = unknown, u = unchanged, - = unimplemented, read as '0', q = value depends on condition.
Shaded cells are unimplemented, read as '0'.

- Note**
- 1: The upper byte of the program counter is not directly accessible. PCLATH is a holding register for PC<15:8> whose contents are updated from, or transferred to, the upper byte of the program counter.
 - 2: The TO and PD status bits in CPUSTA are not affected by a MCLR Reset.
 - 3: Bank 8 and associated registers are only implemented on the PIC17C76X devices.
 - 4: This is the value that will be in the port output latch.
 - 5: When the device is configured for Microprocessor or Extended Microcontroller mode, the operation of this port does not rely on these registers.
 - 6: On any device RESET, these pins are configured as inputs.

PIC17C7XX

TABLE 7-3: SPECIAL FUNCTION REGISTERS (CONTINUED)

Address	Name	Bit 7	Bit 6	Bit 5	Bit 4	Bit 3	Bit 2	Bit 1	Bit 0	Value on POR, BOR	MCLR, WDT
Bank 6											
10h	SSPADD	SSP Address Register in I ² C Slave mode. SSP Baud Rate Reload Register in I ² C Master mode								0000 0000	0000 0000
11h	SSPCON1	WCOL	SSPOV	SSPEN	CKP	SSPM3	SSPM2	SSPM1	SSPM0	0000 0000	0000 0000
12h	SSPCON2	GCEN	AKSTAT	AKDT	AKEN	RCEN	PEN	RSEN	SEN	0000 0000	0000 0000
13h	SSPSTAT	SMP	CKE	D/Ā	P	S	R/W	UA	BF	0000 0000	0000 0000
14h	SSPBUF	Synchronous Serial Port Receive Buffer/Transmit Register								xxxx xxxx	uuuu uuuu
15h	Unimplemented	—	—	—	—	—	—	—	—	-----	-----
16h	Unimplemented	—	—	—	—	—	—	—	—	-----	-----
17h	Unimplemented	—	—	—	—	—	—	—	—	-----	-----
Bank 7											
10h	PW3DCL	DC1	DC0	TM2PW3	—	—	—	—	—	xx0- ----	uu0- ----
11h	PW3DCH	DC9	DC8	DC7	DC6	DC5	DC4	DC3	DC2	xxxx xxxx	uuuu uuuu
12h	CA3L	Capture3 Low Byte								xxxx xxxx	uuuu uuuu
13h	CA3H	Capture3 High Byte								xxxx xxxx	uuuu uuuu
14h	CA4L	Capture4 Low Byte								xxxx xxxx	uuuu uuuu
15h	CA4H	Capture4 High Byte								xxxx xxxx	uuuu uuuu
16h	TCON3	—	CA4OVF	CA3OVF	CA4ED1	CA4ED0	CA3ED1	CA3ED0	PWM3ON	-000 0000	-000 0000
17h	Unimplemented	—	—	—	—	—	—	—	—	-----	-----
Bank 8⁽³⁾											
10h ⁽³⁾	DDRH	Data Direction Register for PORTH								1111 1111	1111 1111
11h ⁽³⁾	PORTH ⁽⁴⁾	RH7/ AN15	RH6/ AN14	RH5/ AN13	RH4/ AN12	RH3	RH2	RH1	RH0	xxxx xxxx	uuuu uuuu
12h ⁽³⁾	DDRJ	Data Direction Register for PORTJ								1111 1111	1111 1111
13h ⁽³⁾	PORTJ ⁽⁴⁾	RJ7	RJ6	RJ5	RJ4	RJ3	RJ2	RJ1	RJ0	xxxx xxxx	uuuu uuuu
14h ⁽³⁾	Unimplemented	—	—	—	—	—	—	—	—	-----	-----
15h ⁽³⁾	Unimplemented	—	—	—	—	—	—	—	—	-----	-----
16h ⁽³⁾	Unimplemented	—	—	—	—	—	—	—	—	-----	-----
17h ⁽³⁾	Unimplemented	—	—	—	—	—	—	—	—	-----	-----
Unbanked											
18h	PRODL	Low Byte of 16-bit Product (8 x 8 Hardware Multiply)								xxxx xxxx	uuuu uuuu
19h	PRODH	High Byte of 16-bit Product (8 x 8 Hardware Multiply)								xxxx xxxx	uuuu uuuu

Legend: x = unknown, u = unchanged, - = unimplemented, read as '0', q = value depends on condition.

Shaded cells are unimplemented, read as '0'.

- Note**
- 1: The upper byte of the program counter is not directly accessible. PCLATH is a holding register for PC<15:8> whose contents are updated from, or transferred to, the upper byte of the program counter.
 - 2: The TO and PD status bits in CPUSTA are not affected by a MCLR Reset.
 - 3: Bank 8 and associated registers are only implemented on the PIC17C76X devices.
 - 4: This is the value that will be in the port output latch.
 - 5: When the device is configured for Microprocessor or Extended Microcontroller mode, the operation of this port does not rely on these registers.
 - 6: On any device RESET, these pins are configured as inputs.

7.2.2.1 ALU Status Register (ALUSTA)

The ALUSTA register contains the status bits of the Arithmetic and Logic Unit and the mode control bits for the indirect addressing register.

As with all the other registers, the ALUSTA register can be the destination for any instruction. If the ALUSTA register is the destination for an instruction that affects the Z, DC, C, or OV bits, then the write to these three bits is disabled. These bits are set or cleared according to the device logic. Therefore, the result of an instruction with the ALUSTA register as destination may be different than intended.

For example, the `CLRF ALUSTA, F` instruction will clear the upper four bits and set the Z bit. This leaves the ALUSTA register as `0000u1uu` (where u = unchanged).

It is recommended, therefore, that only `BCF`, `BSE`, `SWAPF` and `MOVWF` instructions be used to alter the ALUSTA register, because these instructions do not affect any status bits. To see how other instructions affect the status bits, see the "Instruction Set Summary."

Note 1: The C and DC bits operate as a borrow and digit borrow bit, respectively, in subtraction. See the `SUBLW` and `SUBWF` instructions for examples.

2: The overflow bit will be set if the 2's complement result exceeds +127, or is less than -128.

The Arithmetic and Logic Unit (ALU) is capable of carrying out arithmetic or logical operations on two operands, or a single operand. All single operand instructions operate either on the WREG register, or the given file register. For two operand instructions, one of the operands is the WREG register and the other is either a file register, or an 8-bit immediate constant.

REGISTER 7-1: ALUSTA REGISTER (ADDRESS: 04h, UNBANKED)

R/W-1	R/W-1	R/W-1	R/W-1	R/W-x	R/W-x	R/W-x	R/W-x
FS3	FS2	FS1	FS0	OV	Z	DC	C
bit 7				bit 0			

bit 7-6	FS3:FS2: FSR1 Mode Select bits 00 = Post auto-decrement FSR1 value 01 = Post auto-increment FSR1 value 1x = FSR1 value does not change
bit 5-4	FS1:FS0: FSR0 Mode Select bits 00 = Post auto-decrement FSR0 value 01 = Post auto-increment FSR0 value 1x = FSR0 value does not change
bit 3	OV: Overflow bit This bit is used for signed arithmetic (2's complement). It indicates an overflow of the 7-bit magnitude, which causes the sign bit (bit7) to change state. 1 = Overflow occurred for signed arithmetic (in this arithmetic operation) 0 = No overflow occurred
bit 2	Z: Zero bit 1 = The result of an arithmetic or logic operation is zero 0 = The result of an arithmetic or logic operation is not zero
bit 1	DC: Digit carry/borrow bit For <code>ADDWF</code> and <code>ADDLW</code> instructions. 1 = A carry-out from the 4th low order bit of the result occurred 0 = No carry-out from the 4th low order bit of the result Note: For borrow, the polarity is reversed.
bit 0	C: Carry/borrow bit For <code>ADDWF</code> and <code>ADDLW</code> instructions. Note that a subtraction is executed by adding the two's complement of the second operand. For rotate (<code>RRCF</code> , <code>RLCF</code>) instructions, this bit is loaded with either the high or low order bit of the source register. 1 = A carry-out from the Most Significant bit of the result occurred 0 = No carry-out from the Most Significant bit of the result Note: For borrow, the polarity is reversed.

Legend:

R = Readable bit	W = Writable bit	U = Unimplemented bit, read as '0'
- n = Value at POR Reset	'1' = Bit is set	'0' = Bit is cleared
		x = Bit is unknown

PIC17C7XX

7.2.2.2 CPU Status Register (CPUSTA)

The CPUSTA register contains the status and control bits for the CPU. This register has a bit that is used to globally enable/disable interrupts. If only a specific interrupt is desired to be enabled/disabled, please refer to the Interrupt Status (INTSTA) register and the Peripheral Interrupt Enable (PIE) registers. The CPUSTA register also indicates if the stack is available and contains the Power-down (PD) and Time-out (TO) bits. The TO, PD, and STKAV bits are not writable. These bits are set and cleared according to device

logic. Therefore, the result of an instruction with the CPUSTA register as destination may be different than intended.

The POR bit allows the differentiation between a Power-on Reset, external MCLR Reset, or a WDT Reset. The BOR bit indicates if a Brown-out Reset occurred.

Note 1: The BOR status bit is a don't care and is not necessarily predictable if the Brown-out circuit is disabled (when the BODEN bit in the Configuration word is programmed).

REGISTER 7-2: CPUSTA REGISTER (ADDRESS: 06h, UNBANKED)

U-0	U-0	R-1	R/W-1	R-1	R-1	R/W-0	R/W-1
—	—	STKAV	GLINTD	TO	PD	POR	BOR
bit 7						bit 0	

bit 7-6 **Unimplemented:** Read as '0'

bit 5 **STKAV:** Stack Available bit

This bit indicates that the 4-bit stack pointer value is Fh, or has rolled over from Fh → 0h (stack overflow).

1 = Stack is available

0 = Stack is full, or a stack overflow may have occurred (once this bit has been cleared by a stack overflow, only a device RESET will set this bit)

bit 4 **GLINTD:** Global Interrupt Disable bit

This bit disables all interrupts. When enabling interrupts, only the sources with their enable bits set can cause an interrupt.

1 = Disable all interrupts

0 = Enables all unmasked interrupts

bit 3 **TO:** WDT Time-out Status bit

1 = After power-up, by a CLRWDT instruction, or by a SLEEP instruction

0 = A Watchdog Timer time-out occurred

bit 2 **PD:** Power-down Status bit

1 = After power-up or by the CLRWDT instruction

0 = By execution of the SLEEP instruction

bit 1 **POR:** Power-on Reset Status bit

1 = No Power-on Reset occurred

0 = A Power-on Reset occurred (must be set by software)

bit 0 **BOR:** Brown-out Reset Status bit

When BODEN Configuration bit is set (enabled):

1 = No Brown-out Reset occurred

0 = A Brown-out Reset occurred (must be set by software)

When BODEN Configuration bit is clear (disabled):

Don't care

Legend:

R = Readable bit

W = Writable bit

U = Unimplemented bit, read as '0'

- n = Value at POR Reset

'1' = Bit is set

'0' = Bit is cleared

x = Bit is unknown

7.2.2.3 TMR0 Status/Control Register (T0STA)

This register contains various control bits. Bit7 (INTEDG) is used to control the edge upon which a signal on the RA0/INT pin will set the RA0/INT interrupt flag. The other bits configure Timer0, its prescaler and clock source.

REGISTER 7-3: T0STA REGISTER (ADDRESS: 05h, UNBANKED)

R/W-0	R/W-0	R/W-0	R/W-0	R/W-0	R/W-0	R/W-0	U-0
INTEDG	T0SE	T0CS	T0PS3	T0PS2	T0PS1	T0PS0	—
							bit 0

- bit 7 **INTEDG:** RA0/INT Pin Interrupt Edge Select bit
 This bit selects the edge upon which the interrupt is detected.
 1 = Rising edge of RA0/INT pin generates interrupt
 0 = Falling edge of RA0/INT pin generates interrupt
- bit 6 **T0SE:** Timer0 External Clock Input Edge Select bit
 This bit selects the edge upon which TMR0 will increment.
When T0CS = 0 (External Clock):
 1 = Rising edge of RA1/T0CKI pin increments TMR0 and/or sets the T0CKIF bit
 0 = Falling edge of RA1/T0CKI pin increments TMR0 and/or sets a T0CKIF bit
When T0CS = 1 (Internal Clock):
 Don't care
- bit 5 **T0CS:** Timer0 Clock Source Select bit
 This bit selects the clock source for Timer0.
 1 = Internal instruction clock cycle (Tcy)
 0 = External clock input on the T0CKI pin
- bit 4-1 **T0PS3:T0PS0:** Timer0 Prescale Selection bits
 These bits select the prescale value for Timer0.
- | T0PS3:T0PS0 | Prescale Value |
|-------------|----------------|
| 0000 | 1:1 |
| 0001 | 1:2 |
| 0010 | 1:4 |
| 0011 | 1:8 |
| 0100 | 1:16 |
| 0101 | 1:32 |
| 0110 | 1:64 |
| 0111 | 1:128 |
| 1xxx | 1:256 |
- bit 0 **Unimplemented:** Read as '0'

Legend:			
R = Readable bit	W = Writable bit	U = Unimplemented bit, read as '0'	
- n = Value at POR Reset	'1' = Bit is set	'0' = Bit is cleared	x = Bit is unknown

PIC17C7XX

7.3 Stack Operation

PIC17C7XX devices have a 16 x 16-bit hardware stack (Figure 7-1). The stack is not part of either the program or data memory space, and the stack pointer is neither readable nor writable. The PC (Program Counter) is “PUSH’d” onto the stack when a `CALL` or `LCALL` instruction is executed, or an interrupt is acknowledged. The stack is “POP’d” in the event of a `RETURN`, `RETLW`, or a `RETFIE` instruction execution. `PCLATH` is not affected by a “PUSH” or a “POP” operation.

The stack operates as a circular buffer, with the stack pointer initialized to '0' after all RESETS. There is a stack available bit (`STKAV`) to allow software to ensure that the stack will not overflow. The `STKAV` bit is set after a device RESET. When the stack pointer equals `Fh`, `STKAV` is cleared. When the stack pointer rolls over from `Fh` to `0h`, the `STKAV` bit will be held clear until a device RESET.

Note 1: There is not a status bit for stack underflow. The `STKAV` bit can be used to detect the underflow which results in the stack pointer being at the Top-of-Stack.

2: There are no instruction mnemonics called `PUSH` or `POP`. These are actions that occur from the execution of the `CALL`, `RETURN`, `RETLW` and `RETFIE` instructions, or the vectoring to an interrupt vector.

3: After a RESET, if a “POP” operation occurs before a “PUSH” operation, the `STKAV` bit will be cleared. This will appear as if the stack is full (underflow has occurred). If a “PUSH” operation occurs next (before another “POP”), the `STKAV` bit will be locked clear. Only a device RESET will cause this bit to set.

After the device is “PUSH’d” sixteen times (without a “POP”), the seventeenth push overwrites the value from the first push. The eighteenth push overwrites the second push (and so on).

7.4 Indirect Addressing

Indirect addressing is a mode of addressing data memory where the data memory address in the instruction is not fixed. That is, the register that is to be read or written can be modified by the program. This can be useful for data tables in the data memory. Figure 7-6 shows the operation of indirect addressing. This depicts the moving of the value to the data memory address specified by the value of the `FSR` register.

Example 7-1 shows the use of indirect addressing to clear RAM in a minimum number of instructions. A similar concept could be used to move a defined number of bytes (block) of data to the `USART` transmit register (`TXREG`). The starting address of the block of data to be transmitted could easily be modified by the program.

FIGURE 7-6: INDIRECT ADDRESSING

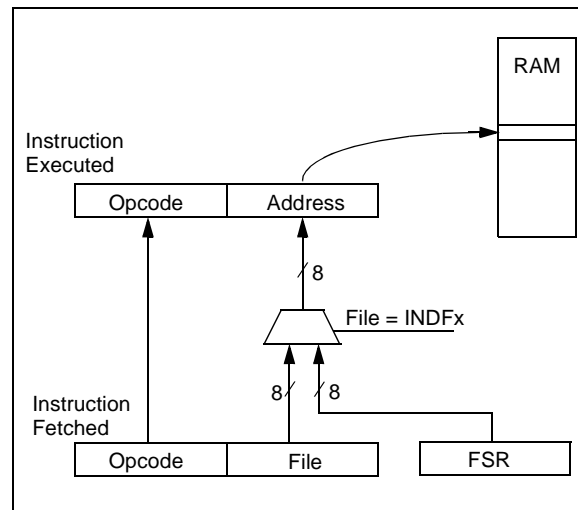

7.4.1 INDIRECT ADDRESSING REGISTERS

The PIC17C7XX has four registers for indirect addressing. These registers are:

- `INDF0` and `FSR0`
- `INDF1` and `FSR1`

Registers `INDF0` and `INDF1` are not physically implemented. Reading or writing to these registers activates indirect addressing, with the value in the corresponding `FSR` register being the address of the data. The `FSR` is an 8-bit register and allows addressing anywhere in the 256-byte data memory address range. For banked memory, the bank of memory accessed is specified by the value in the `BSR`.

If file `INDF0` (or `INDF1`) itself is read indirectly via an `FSR`, all '0's are read (Zero bit is set). Similarly, if `INDF0` (or `INDF1`) is written to indirectly, the operation will be equivalent to a `NOP`, and the status bits are not affected.

7.4.2 INDIRECT ADDRESSING OPERATION

The indirect addressing capability has been enhanced over that of the PIC16CXX family. There are two control bits associated with each FSR register. These two bits configure the FSR register to:

- Auto-decrement the value (address) in the FSR after an indirect access
- Auto-increment the value (address) in the FSR after an indirect access
- No change to the value (address) in the FSR after an indirect access

These control bits are located in the ALUSTA register. The FSR1 register is controlled by the FS3:FS2 bits and FSR0 is controlled by the FS1:FS0 bits.

When using the auto-increment or auto-decrement features, the effect on the FSR is not reflected in the ALUSTA register. For example, if the indirect address causes the FSR to equal '0', the Z bit will not be set.

If the FSR register contains a value of 0h, an indirect read will read 0h (Zero bit is set) while an indirect write will be equivalent to a NOP (status bits are not affected).

Indirect addressing allows single cycle data transfers within the entire data space. This is possible with the use of the MOVFP and MOVFP instructions, where either 'p' or 'f' is specified as INDF0 (or INDF1).

If the source or destination of the indirect address is in banked memory, the location accessed will be determined by the value in the BSR.

A simple program to clear RAM from 20h - FFh is shown in Example 7-1.

EXAMPLE 7-1: INDIRECT ADDRESSING

```

MOV LW 0x20      ;
MOV WF FSR0     ; FSR0 = 20h
BCF ALUSTA, FS1 ; Increment FSR
BSF ALUSTA, FS0 ; after access
BCF ALUSTA, C   ; C = 0
MOV LW END_RAM + 1 ;
LP CLRF INDF0, F ; Addr(FSR) = 0
CPFSEQ FSR0    ; FSR0 = END_RAM+1?
GOTO LP       ; NO, clear next
:             ; YES, All RAM is
:             ; cleared
    
```

7.5 Table Pointer (TBLPTRL and TBLPTRH)

File registers TBLPTRL and TBLPTRH form a 16-bit pointer to address the 64K program memory space. The table pointer is used by instructions TABLWT and TABLRD.

The TABLRD and the TABLWT instructions allow transfer of data between program and data space. The table pointer serves as the 16-bit address of the data word within the program memory. For a more complete description of these registers and the operation of Table Reads and Table Writes, see Section 8.0.

7.6 Table Latch (TBLATH, TBLATL)

The table latch (TBLAT) is a 16-bit register, with TBLATH and TBLATL referring to the high and low bytes of the register. It is not mapped into data or program memory. The table latch is used as a temporary holding latch during data transfer between program and data memory (see TABLRD, TABLWT, TLRD and TLWT instruction descriptions). For a more complete description of these registers and the operation of Table Reads and Table Writes, see Section 8.0.

PIC17C7XX

7.7 Program Counter Module

The Program Counter (PC) is a 16-bit register. PCL, the low byte of the PC, is mapped in the data memory. PCL is readable and writable just as is any other register. PCH is the high byte of the PC and is not directly addressable. Since PCH is not mapped in data or program memory, an 8-bit register PCLATH (PC high latch) is used as a holding latch for the high byte of the PC. PCLATH is mapped into data memory. The user can read or write PCH through PCLATH.

The 16-bit wide PC is incremented after each instruction fetch during Q1 unless:

- Modified by a GOTO, CALL, LCALL, RETURN, RETLW, or RETFIE instruction
- Modified by an interrupt response
- Due to destination write to PCL by an instruction

“Skips” are equivalent to a forced NOP cycle at the skipped address.

Figure 7-7 and Figure 7-8 show the operation of the program counter for various situations.

FIGURE 7-7: PROGRAM COUNTER OPERATION

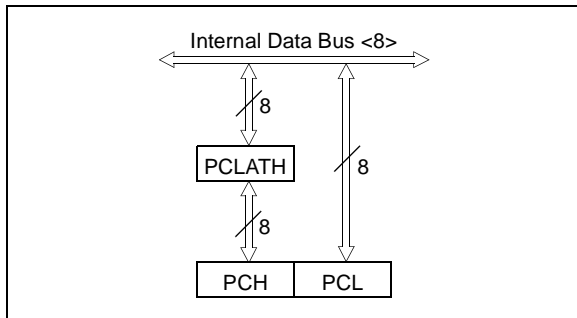
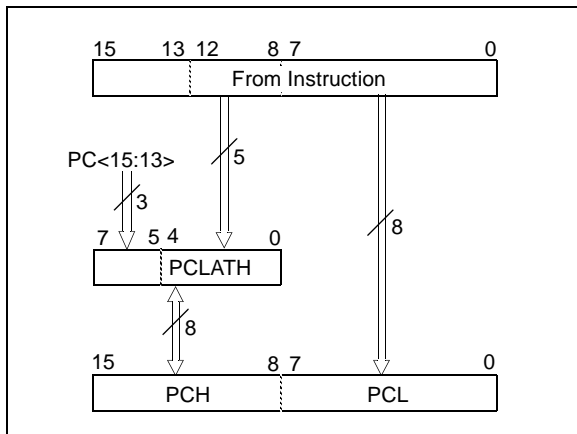

FIGURE 7-8: PROGRAM COUNTER USING THE CALL AND GOTO INSTRUCTIONS



Using Figure 7-7, the operations of the PC and PCLATH for different instructions are as follows:

- LCALL instructions:**
An 8-bit destination address is provided in the instruction (opcode). PCLATH is unchanged.
PCLATH → PCH
Opcode<7:0> → PCL
- Read instructions on PCL:**
Any instruction that reads PCL.
PCL → data bus → ALU or destination
PCH → PCLATH
- Write instructions on PCL:**
Any instruction that writes to PCL.
8-bit data → data bus → PCL
PCLATH → PCH
- Read-Modify-Write instructions on PCL:**
Any instruction that does a read-write-modify operation on PCL, such as ADDWF PCL.
Read: PCL → data bus → ALU
Write: 8-bit result → data bus → PCL
PCLATH → PCH
- RETURN instruction:**
Stack<MRU> → PC<15:0>

Using Figure 7-8, the operation of the PC and PCLATH for GOTO and CALL instructions is as follows:

CALL, GOTO instructions:

- A 13-bit destination address is provided in the instruction (opcode).
- Opcode<12:0> → PC<12:0>
- PC<15:13> → PCLATH<7:5>
- Opcode<12:8> → PCLATH<4:0>

The read-modify-write only affects the PCL with the result. PCH is loaded with the value in the PCLATH. For example, ADDWF PCL will result in a jump within the current page. If PC = 03F0h, WREG = 30h and PCLATH = 03h before instruction, PC = 0320h after the instruction. To accomplish a true 16-bit computed jump, the user needs to compute the 16-bit destination address, write the high byte to PCLATH and then write the low value to PCL.

The following PC related operations do not change PCLATH:

- LCALL, RETLW, and RETFIE instructions.
- Interrupt vector is forced onto the PC.
- Read-modify-write instructions on PCL (e.g. BSF PCL).

7.8 Bank Select Register (BSR)

The BSR is used to switch between banks in the data memory area (Figure 7-9). In the PIC17C7XX devices, the entire byte is implemented. The lower nibble is used to select the peripheral register bank. The upper nibble is used to select the general purpose memory bank.

All the Special Function Registers (SFRs) are mapped into the data memory space. In order to accommodate the large number of registers, a banking scheme has been used. A segment of the SFRs, from address 10h to address 17h, is banked. The lower nibble of the bank select register (BSR) selects the currently active “peripheral bank.” Effort has been made to group the peripheral registers of related functionality in one bank. However, it will still be necessary to switch from bank to

bank in order to address all peripherals related to a single task. To assist this, a `MOVLB` bank instruction has been included in the instruction set.

The need for a large general purpose memory space dictated a general purpose RAM banking scheme. The upper nibble of the BSR selects the currently active general purpose RAM bank. To assist this, a `MOVLR` bank instruction has been provided in the instruction set.

If the currently selected bank is not implemented (such as Bank 13), any read will read all '0's. Any write is completed to the bit bucket and the ALU status bits will be set/cleared as appropriate.

Note: Registers in Bank 15 in the Special Function Register area, are reserved for Microchip use. Reading of registers in this bank may cause random values to be read.

FIGURE 7-9: BSR OPERATION

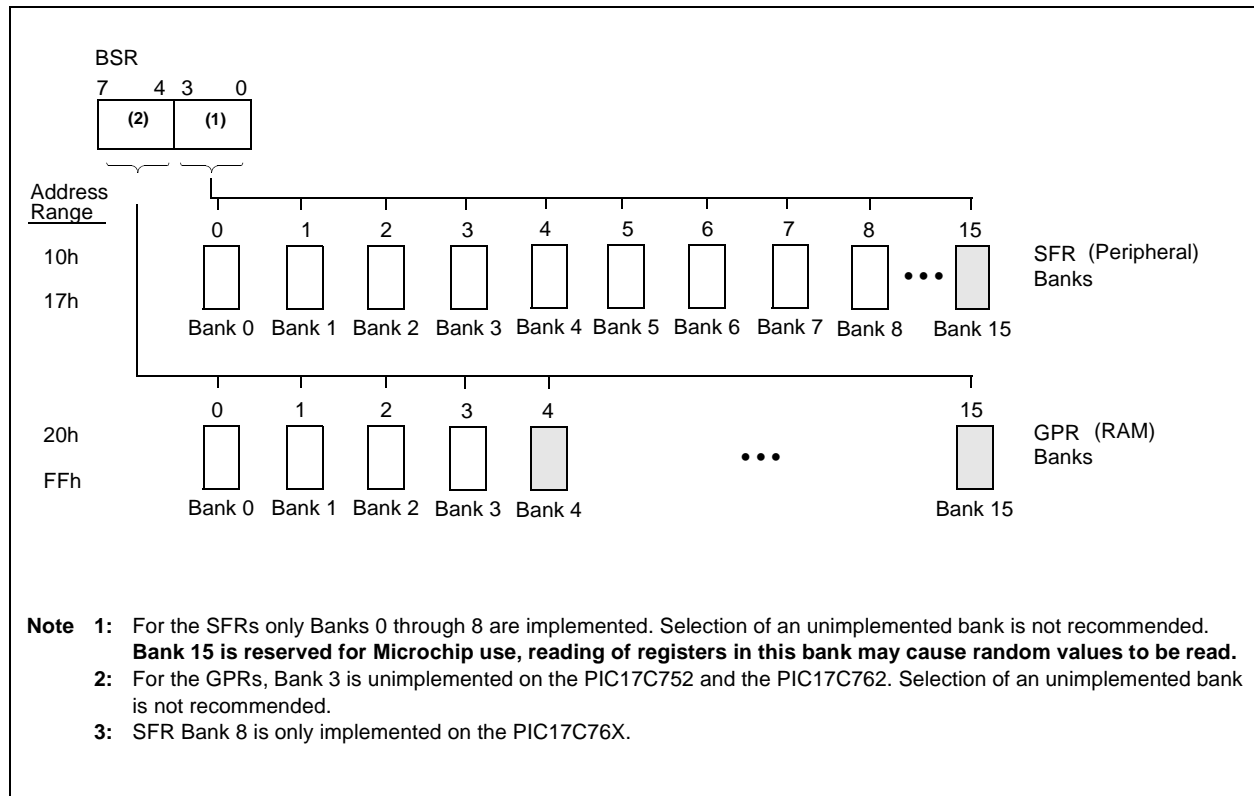

PIC17C7XX

NOTES:

8.0 TABLE READS AND TABLE WRITES

The PIC17C7XX has four instructions that allow the processor to move data from the data memory space to the program memory space, and vice versa. Since the program memory space is 16-bits wide and the data memory space is 8-bits wide, two operations are required to move 16-bit values to/from the data memory.

The TLWT *t, f* and TABLWT *t, i, f* instructions are used to write data from the data memory space to the program memory space. The TLRD *t, f* and TABLRD *t, i, f* instructions are used to write data from the program memory space to the data memory space.

The program memory can be internal or external. For the program memory access to be external, the device needs to be operating in Microprocessor or Extended Microcontroller mode.

Figure 8-1 through Figure 8-4 show the operation of these four instructions. The steps show the sequence of operation.

FIGURE 8-1: TLWT INSTRUCTION OPERATION

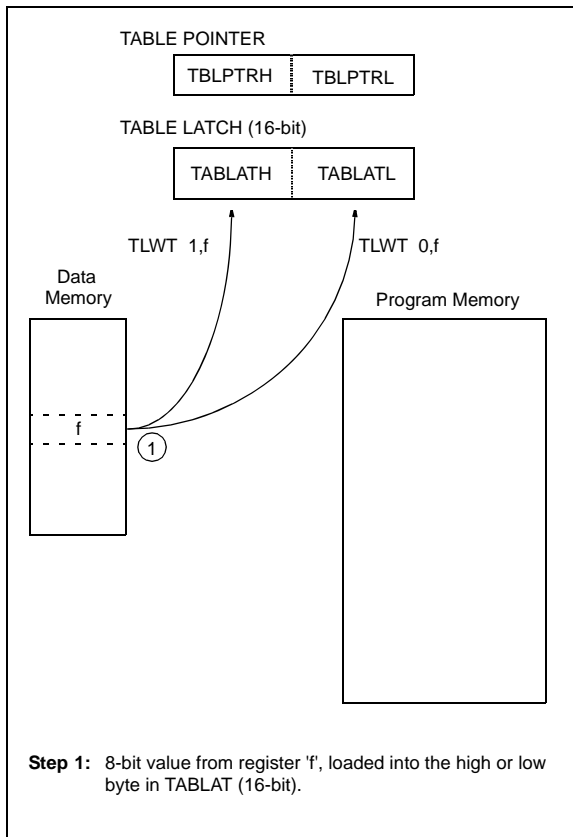
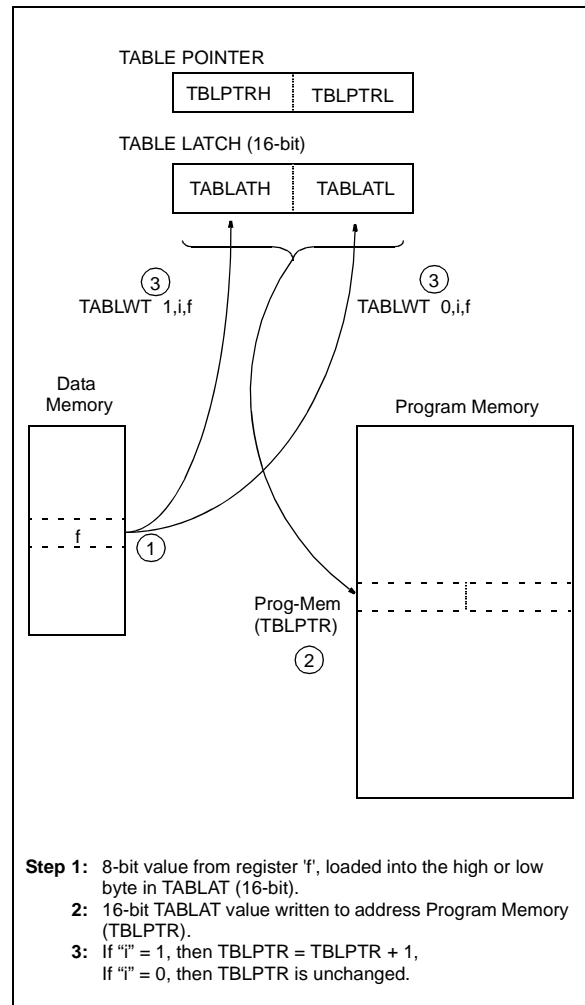

FIGURE 8-2: TABLWT INSTRUCTION OPERATION



PIC17C7XX

FIGURE 8-3: TLRD INSTRUCTION OPERATION

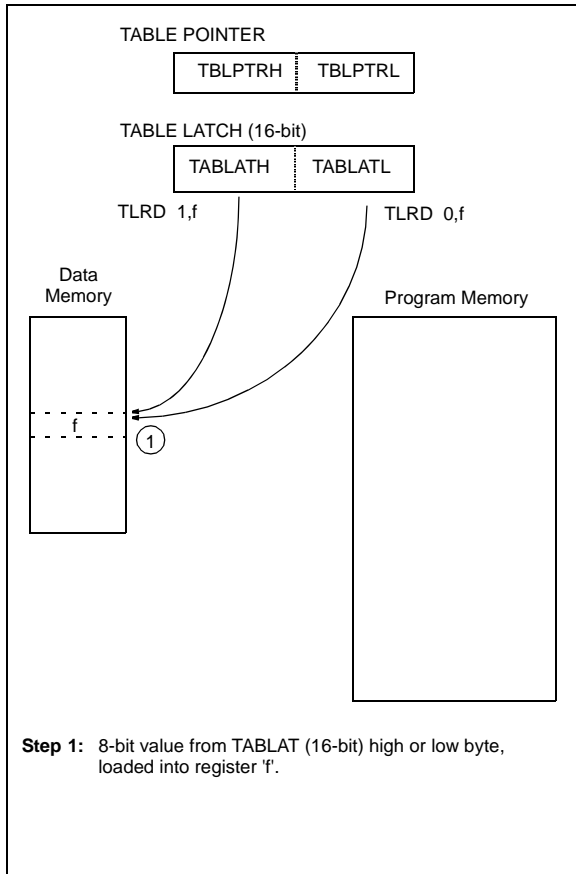
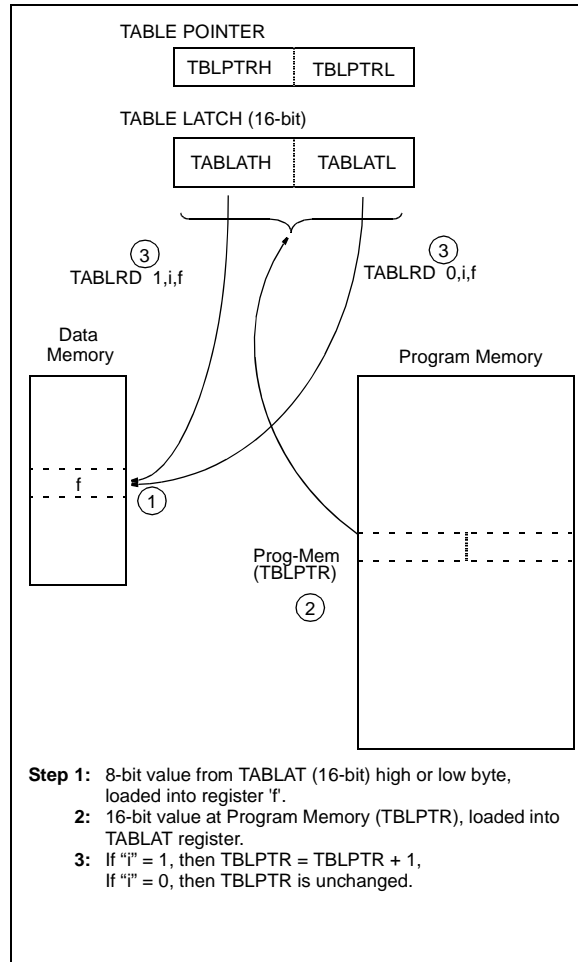

FIGURE 8-4: TABLRD INSTRUCTION OPERATION



8.1 Table Writes to Internal Memory

A table write operation to internal memory causes a long write operation. The long write is necessary for programming the internal EPROM. Instruction execution is halted while in a long write cycle. The long write will be terminated by any enabled interrupt. To ensure that the EPROM location has been well programmed, a minimum programming time is required (see specification #D114). Having only one interrupt enabled to terminate the long write ensures that no unintentional interrupts will prematurely terminate the long write.

The sequence of events for programming an internal program memory location should be:

1. Disable all interrupt sources, except the source to terminate EPROM program write.
2. Raise $\overline{\text{MCLR}}/\text{VPP}$ pin to the programming voltage.
3. Clear the WDT.
4. Do the table write. The interrupt will terminate the long write.
5. Verify the memory location (table read).

Note 1: Programming requirements must be met. See timing specification in electrical specifications for the desired device. Violating these specifications (including temperature) may result in EPROM locations that are not fully programmed and may lose their state over time.

2: If the VPP requirement is not met, the table write is a 2-cycle write and the program memory is unchanged.

8.1.1 TERMINATING LONG WRITES

An interrupt source or RESET are the only events that terminate a long write operation. Terminating the long write from an interrupt source requires that the interrupt enable and flag bits are set. The GLINTD bit only enables the vectoring to the interrupt address.

If the T0CKI, RA0/INT, or TMR0 interrupt source is used to terminate the long write, the interrupt flag of the highest priority enabled interrupt, will terminate the long write and automatically be cleared.

Note 1: If an interrupt is pending, the TABLWRT is aborted (a NOP is executed). The highest priority pending interrupt, from the T0CKI, RA0/INT, or TMR0 sources that is enabled, has its flag cleared.

2: If the interrupt is not being used for the program write timing, the interrupt should be disabled. This will ensure that the interrupt is not lost, nor will it terminate the long write prematurely.

If a peripheral interrupt source is used to terminate the long write, the interrupt enable and flag bits must be set. The interrupt flag will not be automatically cleared upon the vectoring to the interrupt vector address.

The GLINTD bit determines whether the program will branch to the interrupt vector when the long write is terminated. If GLINTD is clear, the program will vector, if GLINTD is set, the program will not vector to the interrupt address.

TABLE 8-1: INTERRUPT - TABLE WRITE INTERACTION

Interrupt Source	GLINTD	Enable Bit	Flag Bit	Action
RA0/INT, TMR0, T0CKI	0	1	1	Terminate long table write (to internal program memory), branch to interrupt vector (branch clears flag bit).
	0	1	0	None.
	1	0	x	None.
	1	1	1	Terminate long table write, do not branch to interrupt vector (flag is automatically cleared).
Peripheral	0	1	1	Terminate long table write, branch to interrupt vector.
	0	1	0	None.
	1	0	x	None.
	1	1	1	Terminate long table write, do not branch to interrupt vector (flag remains set).

PIC17C7XX

8.2 Table Writes to External Memory

Table writes to external memory are always two-cycle instructions. The second cycle writes the data to the external memory location. The sequence of events for an external memory write are the same for an internal write.

8.2.1 TABLE WRITE CODE

The “i” operand of the `TABLWT` instruction can specify that the value in the 16-bit `TBLPTR` register is automatically incremented (for the next write). In Example 8-1, the `TBLPTR` register is not automatically incremented.

EXAMPLE 8-1: TABLE WRITE

```

CLRWDT           ; Clear WDT
MOVLW  HIGH (TBL_ADDR) ; Load the Table
MOVWF  TBLPTRH   ; address
MOVLW  LOW (TBL_ADDR)  ;
MOVWF  TBLPTRL   ;
MOVLW  HIGH (DATA)    ; Load HI byte
TLWT   1, WREG       ; in TABLATH
MOVLW  LOW (DATA)    ; Load LO byte
TABLWT 0,0,WREG      ; in TABLATL
                                ; and write to
                                ; program memory
                                ; (Ext. SRAM)
    
```

FIGURE 8-5: TABLWT WRITE TIMING (EXTERNAL MEMORY)

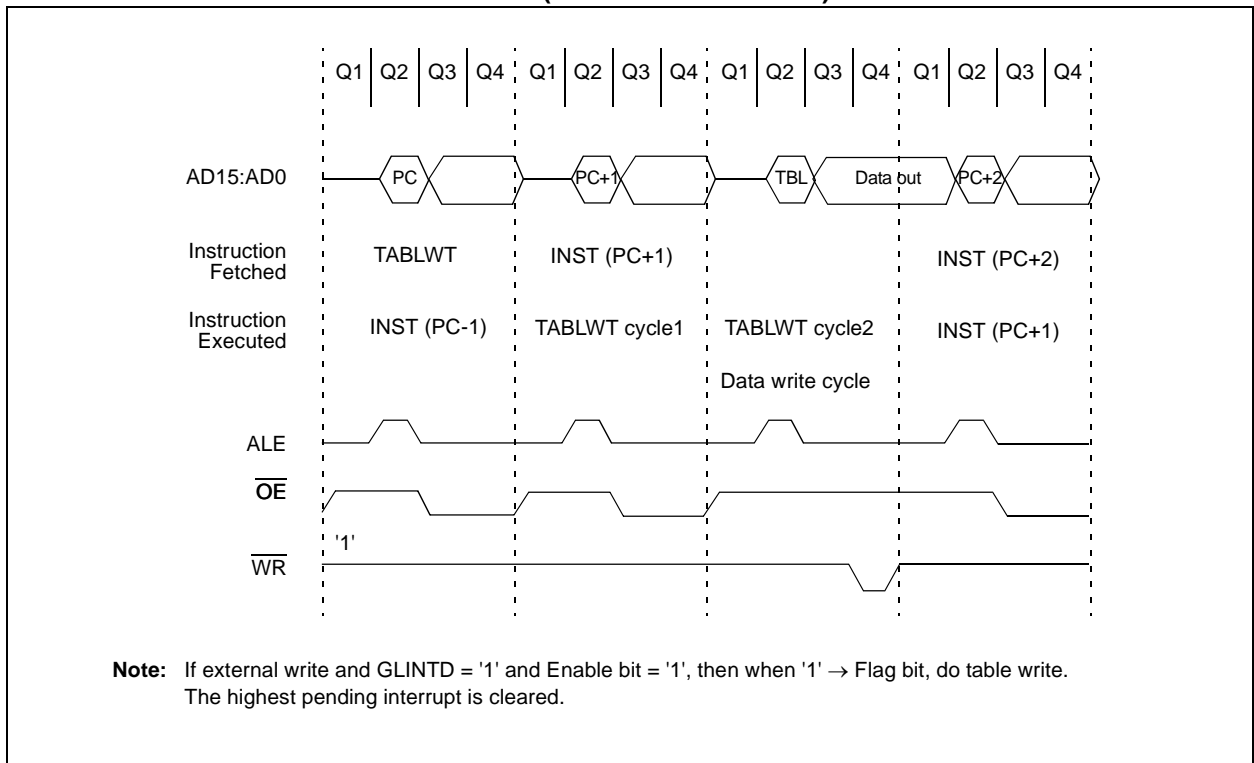
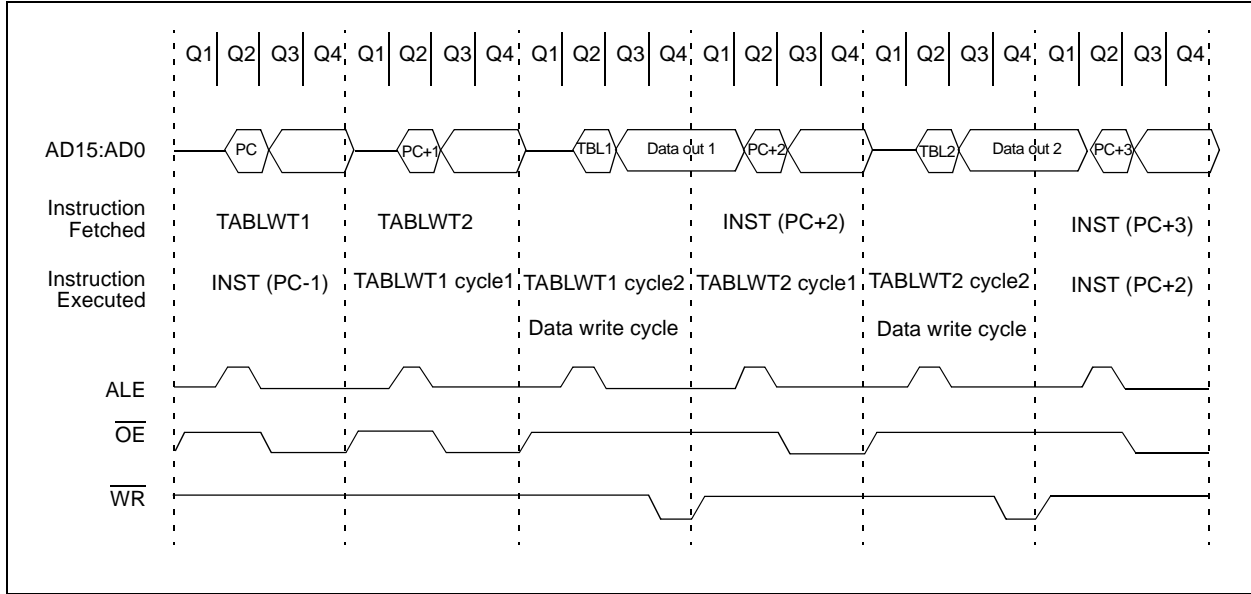

FIGURE 8-6: CONSECUTIVE TABLWT WRITE TIMING (EXTERNAL MEMORY)



PIC17C7XX

8.3 Table Reads

The table read allows the program memory to be read. This allows constants to be stored in the program memory space and retrieved into data memory when needed. Example 8-2 reads the 16-bit value at program memory address TBLPTR. After the dummy byte has been read from the TABLATH, the TABLATH is loaded with the 16-bit data from program memory address TBLPTR and then increments the TBLPTR value. The first read loads the data into the latch and can be considered a dummy read (unknown data loaded into 'f'). INDF0 should be configured for either auto-increment or auto-decrement.

EXAMPLE 8-2: TABLE READ

```

MOVLW HIGH (TBL_ADDR) ; Load the Table
MOVWF TBLPTRH          ; address
MOVLW LOW (TBL_ADDR)  ;
MOVWF TBLPTRL         ;
TABLRD 0, 1, DUMMY    ; Dummy read,
                        ; Updates TABLATH
                        ; Increments TBLPTR
TLRD   1, INDF0       ; Read HI byte
                        ; of TABLATH
TABLRD 0, 1, INDF0    ; Read LO byte
                        ; of TABLATL and
                        ; Update TABLATH
                        ; Increment TBLPTR
    
```

FIGURE 8-7: TABLRD TIMING

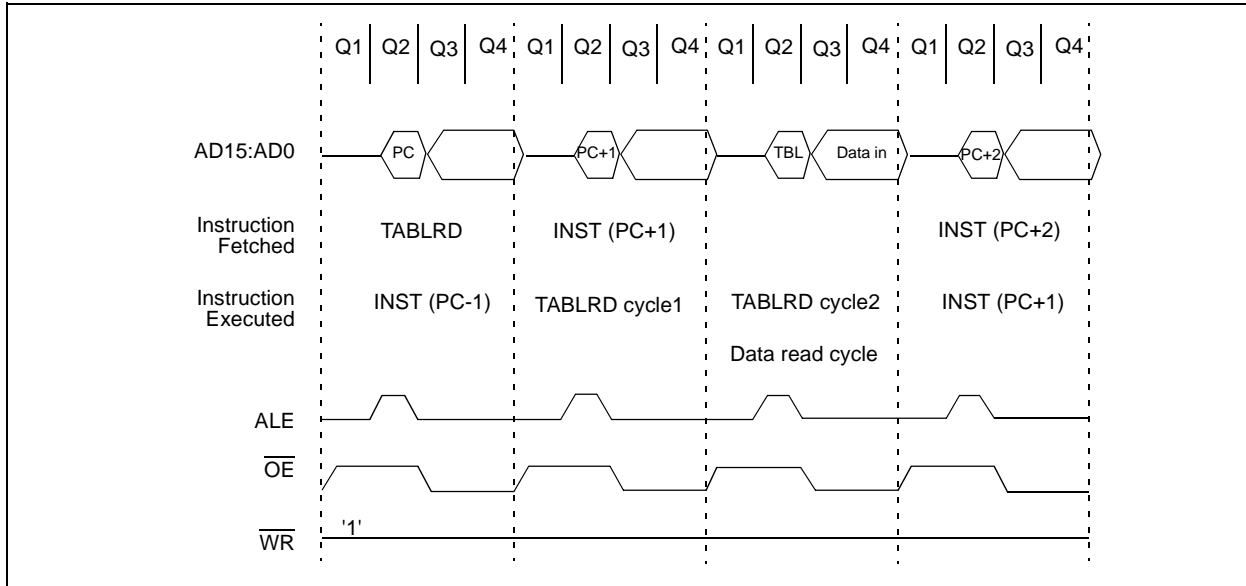
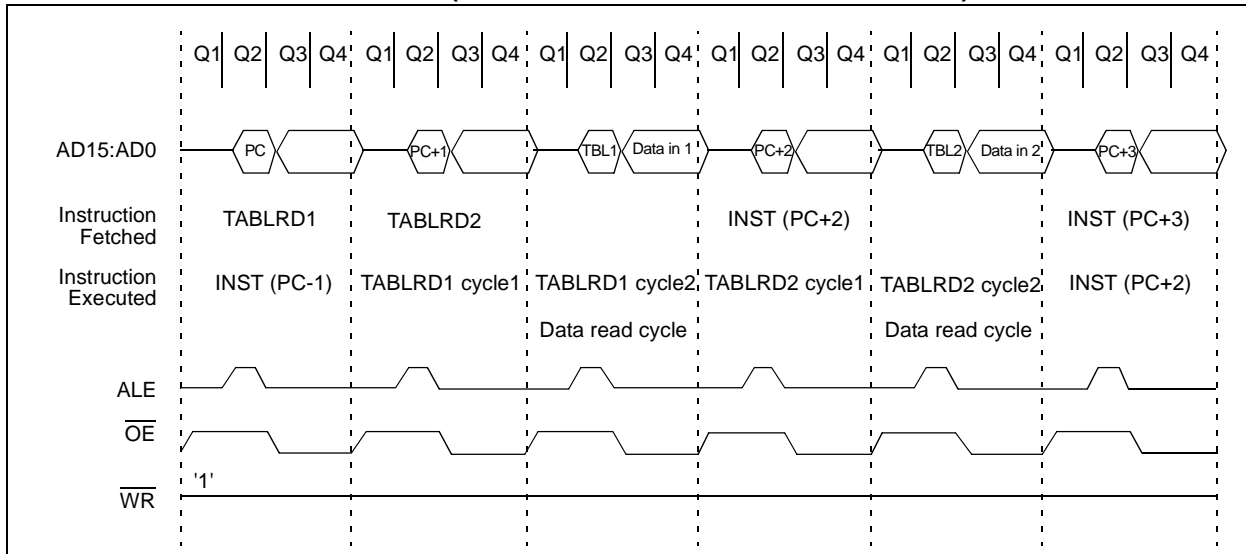

FIGURE 8-8: TABLRD TIMING (CONSECUTIVE TABLRD INSTRUCTIONS)



8.4 Operation with External Memory Interface

When the table reads/writes are accessing external memory (via the external system interface bus), the table latch for the table reads is different from the table latch for the table writes (see Figure 8-9).

This means that you cannot do a `TABLWD` instruction, and use the values that were loaded into the table latches for a `TABLWT` instruction. Any table write sequence should use both the `TLWT` and then the `TABLWT` instructions.

FIGURE 8-9: ACCESSING EXTERNAL MEMORY WITH `TABLWD` AND `TABLWT` INSTRUCTIONS

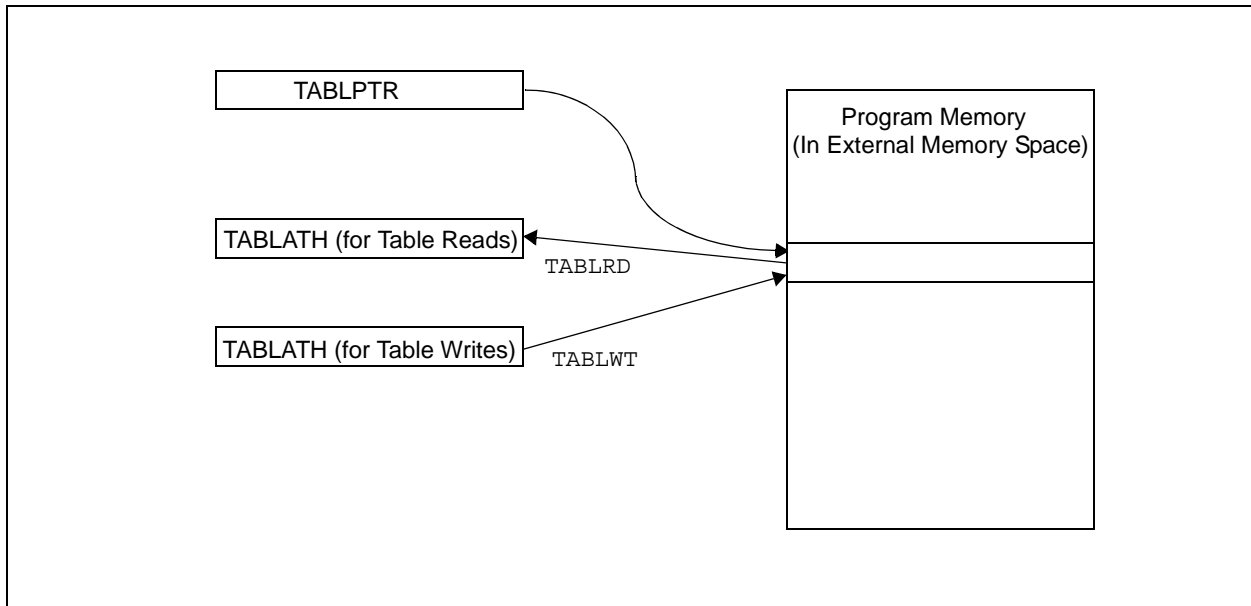

PIC17C7XX

NOTES:

9.0 HARDWARE MULTIPLIER

All PIC17C7XX devices have an 8 x 8 hardware multiplier included in the ALU of the device. By making the multiply a hardware operation, it completes in a single instruction cycle. This is an unsigned multiply that gives a 16-bit result. The result is stored into the 16-bit Product register (PRODH:PRODL). The multiplier does not affect any flags in the ALUSTA register.

Making the 8 x 8 multiplier execute in a single cycle gives the following advantages:

- Higher computational throughput
- Reduces code size requirements for multiply algorithms

The performance increase allows the device to be used in applications previously reserved for Digital Signal Processors.

Table 9-1 shows a performance comparison between PIC17CXXX devices using the single cycle hardware multiply and performing the same function without the hardware multiply.

Example 9-1 shows the sequence to do an 8 x 8 unsigned multiply. Only one instruction is required when one argument of the multiply is already loaded in the WREG register.

Example 9-2 shows the sequence to do an 8 x 8 signed multiply. To account for the sign bits of the arguments, each argument's most significant bit (MSb) is tested and the appropriate subtractions are done.

EXAMPLE 9-1: 8 x 8 UNSIGNED MULTIPLY ROUTINE

```
MOVFP ARG1, WREG ;
MULWF ARG2      ; ARG1 * ARG2 ->
                ;   PRODH:PRODL
```

EXAMPLE 9-2: 8 x 8 SIGNED MULTIPLY ROUTINE

```
MOVFP ARG1, WREG
MULWF ARG2      ; ARG1 * ARG2 ->
                ;   PRODH:PRODL

BTFSC ARG2, SB  ; Test Sign Bit
SUBWF PRODH, F  ; PRODH = PRODH
                ;   - ARG1

MOVFP ARG2, WREG
BTFSC ARG1, SB  ; Test Sign Bit
SUBWF PRODH, F  ; PRODH = PRODH
                ;   - ARG2
```

TABLE 9-1: PERFORMANCE COMPARISON

Routine	Multiply Method	Program Memory (Words)	Cycles (Max)	Time		
				@ 33 MHz	@ 16 MHz	@ 8 MHz
8 x 8 unsigned	Without hardware multiply	13	69	8.364 μs	17.25 μs	34.50 μs
	Hardware multiply	1	1	0.121 μs	0.25 μs	0.50 μs
8 x 8 signed	Without hardware multiply	—	—	—	—	—
	Hardware multiply	6	6	0.727 μs	1.50 μs	3.0 μs
16 x 16 unsigned	Without hardware multiply	21	242	29.333 μs	60.50 μs	121.0 μs
	Hardware multiply	24	24	2.91 μs	6.0 μs	12.0 μs
16 x 16 signed	Without hardware multiply	52	254	30.788 μs	63.50 μs	127.0 μs
	Hardware multiply	36	36	4.36 μs	9.0 μs	18.0 μs

PIC17C7XX

Example 9-3 shows the sequence to do a 16 x 16 unsigned multiply. Equation 9-1 shows the algorithm that is used. The 32-bit result is stored in 4 registers, RES3:RES0.

EQUATION 9-1: 16 x 16 UNSIGNED MULTIPLICATION ALGORITHM

$$\begin{aligned} \text{RES3:RES0} &= \text{ARG1H:ARG1L} \cdot \text{ARG2H:ARG2L} \\ &= (\text{ARG1H} \cdot \text{ARG2H} \cdot 2^{16}) + \\ &\quad (\text{ARG1H} \cdot \text{ARG2L} \cdot 2^8) + \\ &\quad (\text{ARG1L} \cdot \text{ARG2H} \cdot 2^8) + \\ &\quad (\text{ARG1L} \cdot \text{ARG2L}) \end{aligned}$$

EXAMPLE 9-3: 16 x 16 UNSIGNED MULTIPLY ROUTINE

```
MOVFP ARG1L, WREG
MULWF ARG2L ; ARG1L * ARG2L ->
; PRODH:PRODL
MOVFP PRODH, RES1 ;
MOVFP PRODL, RES0 ;
;
MOVFP ARG1H, WREG
MULWF ARG2H ; ARG1H * ARG2H ->
; PRODH:PRODL
MOVFP PRODH, RES3 ;
MOVFP PRODL, RES2 ;
;
MOVFP ARG1L, WREG
MULWF ARG2H ; ARG1L * ARG2H ->
; PRODH:PRODL
MOVFP PRODL, WREG ;
ADDWF RES1, F ; Add cross
MOVFP PRODH, WREG ; products
ADDWFC RES2, F ;
CLRf WREG, F ;
ADDWFC RES3, F ;
;
MOVFP ARG1H, WREG ;
MULWF ARG2L ; ARG1H * ARG2L ->
; PRODH:PRODL
MOVFP PRODL, WREG ;
ADDWF RES1, F ; Add cross
MOVFP PRODH, WREG ; products
ADDWFC RES2, F ;
CLRf WREG, F ;
ADDWFC RES3, F ;
```

Example 9-4 shows the sequence to do a 16 x 16 signed multiply. Equation 9-2 shows the algorithm used. The 32-bit result is stored in four registers, RES3:RES0. To account for the sign bits of the arguments, each argument pairs most significant bit (MSb) is tested and the appropriate subtractions are done.

EQUATION 9-2: 16 x 16 SIGNED MULTIPLICATION ALGORITHM

$$\begin{aligned}
 &RES3:RES0 \\
 &= ARG1H:ARG1L \bullet ARG2H:ARG2L \\
 &= (ARG1H \bullet ARG2H \bullet 2^{16}) \quad + \\
 &\quad (ARG1H \bullet ARG2L \bullet 2^8) \quad + \\
 &\quad (ARG1L \bullet ARG2H \bullet 2^8) \quad + \\
 &\quad (ARG1L \bullet ARG2L) \quad + \\
 &\quad (-1 \bullet ARG2H<7> \bullet ARG1H:ARG1L \bullet 2^{16}) \quad + \\
 &\quad (-1 \bullet ARG1H<7> \bullet ARG2H:ARG2L \bullet 2^{16})
 \end{aligned}$$

EXAMPLE 9-4: 16 x 16 SIGNED MULTIPLY ROUTINE

```

MOVFP ARG1L, WREG
MULWF ARG2L      ; ARG1L * ARG2L ->
                  ;   PRODH:PRODL
MOVFP PRODH, RES1 ;
MOVFP PRODL, RES0 ;
;
MOVFP ARG1H, WREG
MULWF ARG2H      ; ARG1H * ARG2H ->
                  ;   PRODH:PRODL
MOVFP PRODH, RES3 ;
MOVFP PRODL, RES2 ;
;
MOVFP ARG1L, WREG
MULWF ARG2H      ; ARG1L * ARG2H ->
                  ;   PRODH:PRODL
MOVFP PRODL, WREG ;
ADDWF RES1, F    ; Add cross
MOVFP PRODH, WREG ;   products
ADDWFC RES2, F   ;
CLRf  WREG, F    ;
ADDWFC RES3, F   ;
;
MOVFP ARG1H, WREG ;
MULWF ARG2L      ; ARG1H * ARG2L ->
                  ;   PRODH:PRODL
MOVFP PRODL, WREG ;
ADDWF RES1, F    ; Add cross
MOVFP PRODH, WREG ;   products
ADDWFC RES2, F   ;
CLRf  WREG, F    ;
ADDWFC RES3, F   ;
;
BTfSS ARG2H, 7   ; ARG2H:ARG2L neg?
GOTO  SIGN_ARG1 ; no, check ARG1
MOVFP ARG1L, WREG ;
SUBWF RES2      ;
MOVFP ARG1H, WREG ;
SUBWFB RES3     ;
;
SIGN_ARG1
BTfSS ARG1H, 7   ; ARG1H:ARG1L neg?
GOTO  CONT_CODE ; no, done
MOVFP ARG2L, WREG ;
SUBWF RES2      ;
MOVFP ARG2H, WREG ;
SUBWFB RES3     ;
;
CONT_CODE
:

```

PIC17C7XX

NOTES:

10.0 I/O PORTS

PIC17C75X devices have seven I/O ports, PORTA through PORTG. PIC17C76X devices have nine I/O ports, PORTA through PORTJ. PORTB through PORTJ have a corresponding Data Direction Register (DDR), which is used to configure the port pins as inputs or outputs. Some of these ports pins are multiplexed with alternate functions.

PORTC, PORTD, and PORTE are multiplexed with the system bus. These pins are configured as the system bus when the device's configuration bits are selected to Microprocessor or Extended Microcontroller modes. In the two other microcontroller modes, these pins are general purpose I/O.

PORTA, PORTB, PORTE<3>, PORTF, PORTG and the upper four bits of PORTH are multiplexed with the peripheral features of the device. These peripheral features are:

- Timer Modules
- Capture Modules
- PWM Modules
- USART/SCI Modules
- SSP Module
- A/D Module
- External Interrupt pin

When some of these peripheral modules are turned on, the port pin will automatically configure to the alternate function. The modules that do this are:

- PWM Module
- SSP Module
- USART/SCI Module

When a pin is automatically configured as an output by a peripheral module, the pins data direction (DDR) bit is unknown. After disabling the peripheral module, the user should re-initialize the DDR bit to the desired configuration.

The other peripheral modules (which require an input) must have their data direction bits configured appropriately.

<p>Note: A pin that is a peripheral input, can be configured as an output (DDRx<y> is cleared). The peripheral events will be determined by the action output on the port pin.</p>

When the device enters the "RESET state", the Data Direction registers (DDR) are forced set, which will make the I/O hi-impedance inputs. The RESET state of some peripheral modules may force the I/O to other operations, such as analog inputs or the system bus.

PIC17C7XX

10.1 PORTA Register

PORTA is a 6-bit wide latch. PORTA does not have a corresponding Data Direction Register (DDR). Upon a device RESET, the PORTA pins are forced to be hi-impedance inputs. For the RA4 and RA5 pins, the peripheral module controls the output. When a device RESET occurs, the peripheral module is disabled, so these pins are forced to be hi-impedance inputs.

Reading PORTA reads the status of the pins.

The RA0 pin is multiplexed with the external interrupt, INT. The RA1 pin is multiplexed with TMR0 clock input, RA2 and RA3 are multiplexed with the SSP functions, and RA4 and RA5 are multiplexed with the USART1 functions. The control of RA2, RA3, RA4 and RA5 as outputs, is automatically configured by their multiplexed peripheral module when the module is enabled.

10.1.1 USING RA2, RA3 AS OUTPUTS

The RA2 and RA3 pins are open drain outputs. To use the RA2 and/or the RA3 pin(s) as output(s), simply write to the PORTA register the desired value. A '0' will cause the pin to drive low, while a '1' will cause the pin to float (hi-impedance). An external pull-up resistor should be used to pull the pin high. Writes to the RA2 and RA3 pins will not affect the other PORTA pins.

Note: When using the RA2 or RA3 pin(s) as output(s), read-modify-write instructions (such as BCF, BSF, BTG) on PORTA are not recommended.

Such operations read the port pins, do the desired operation, and then write this value to the data latch. This may inadvertently cause the RA2 or RA3 pins to switch from input to output (or vice-versa).

To avoid this possibility, use a shadow register for PORTA. Do the bit operations on this shadow register and then move it to PORTA.

Example 10-1 shows an instruction sequence to initialize PORTA. The Bank Select Register (BSR) must be selected to Bank 0 for the port to be initialized. The following example uses the MOVLB instruction to load the BSR register for bank selection.

EXAMPLE 10-1: INITIALIZING PORTA

```
MOVLB 0 ; Select Bank 0
MOVLW 0xF3 ;
MOVWF PORTA ; Initialize PORTA
; RA<3:2> are output low
; RA<5:4> and RA<1:0>
; are inputs
; (outputs floating)
```

FIGURE 10-1: RA0 AND RA1 BLOCK DIAGRAM

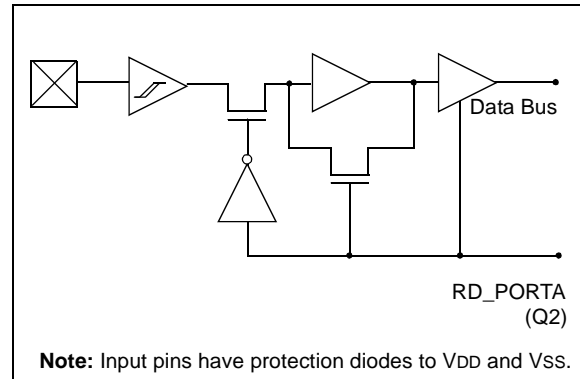

FIGURE 10-2: RA2 BLOCK DIAGRAM

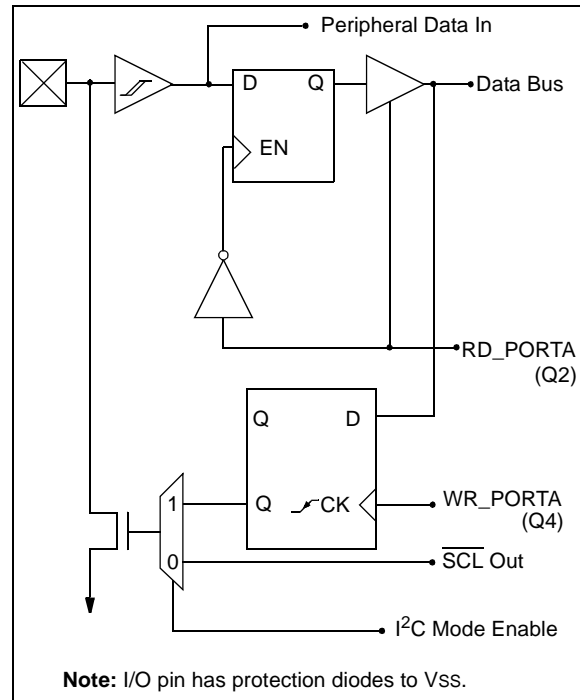

FIGURE 10-3: RA3 BLOCK DIAGRAM

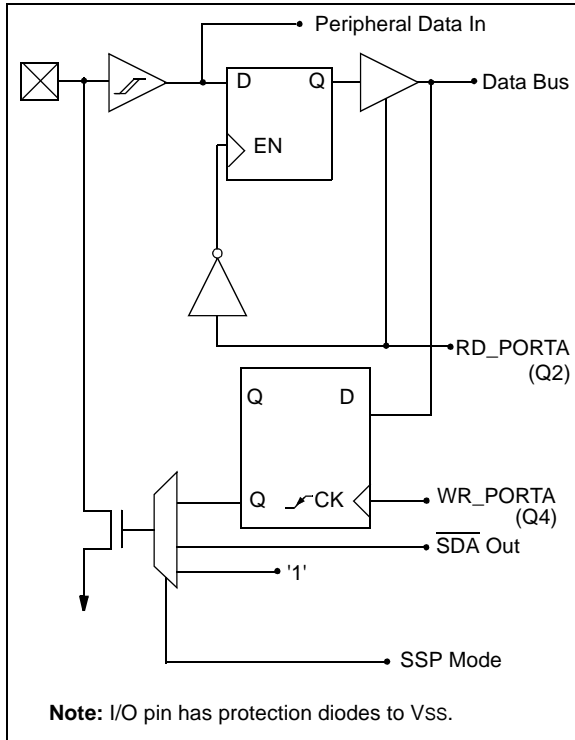

FIGURE 10-4: RA4 AND RA5 BLOCK DIAGRAM

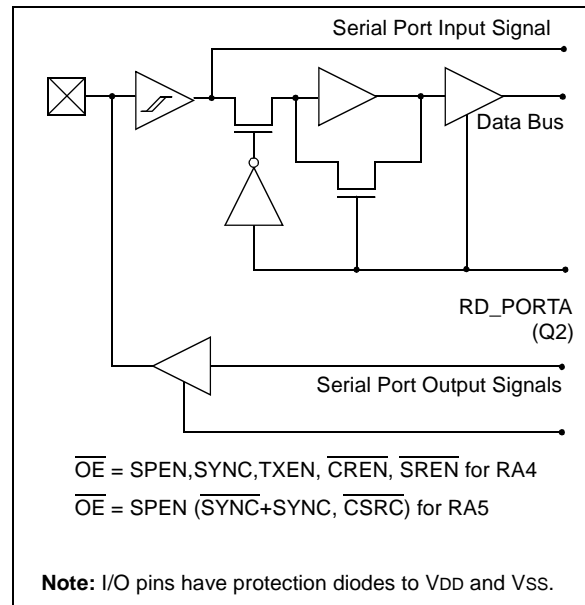

TABLE 10-1: PORTA FUNCTIONS

Name	Bit0	Buffer Type	Function
RA0/INT	bit0	ST	Input or external interrupt input.
RA1/T0CKI	bit1	ST	Input or clock input to the TMR0 timer/counter and/or an external interrupt input.
RA2/ \overline{SS} /SCL	bit2	ST	Input/output or slave select input for the SPI, or clock input for the I ² C bus. Output is open drain type.
RA3/SDI/SDA	bit3	ST	Input/output or data input for the SPI, or data for the I ² C bus. Output is open drain type.
RA4/RX1/DT1	bit4	ST	Input or USART1 Asynchronous Receive input, or USART1 Synchronous Data input/output.
RA5/TX1/CK1	bit5	ST	Input or USART1 Asynchronous Transmit output, or USART1 Synchronous Clock input/output.
\overline{RBPU}	bit7	—	Control bit for PORTB weak pull-ups.

Legend: ST = Schmitt Trigger input

TABLE 10-2: REGISTERS/BITS ASSOCIATED WITH PORTA

Address	Name	Bit 7	Bit 6	Bit 5	Bit 4	Bit 3	Bit 2	Bit 1	Bit 0	Value on POR, BOR	\overline{MCLR} , WDT
10h, Bank 0	PORTA ⁽¹⁾	RBPU	—	RA5/TX1/CK1	RA4/RX1/DT1	RA3/SDI/SDA	RA2/ \overline{SS} /SCL	RA1/T0CKI	RA0/INT	0-xx 11xx	0-uu 11uu
05h, Unbanked	T0STA	INTEDG	T0SE	T0CS	T0PS3	T0PS2	T0PS1	T0PS0	—	0000 000-	0000 000-
13h, Bank 0	RCSTA1	SPEN	RX9	SREN	CREN	—	FERR	OERR	RX9D	0000 -00x	0000 -00u
15h, Bank 0	TXSTA1	CSRC	TX9	TXEN	SYNC	—	—	TRMT	TX9D	0000 --1x	0000 --1u

Legend: x = unknown, u = unchanged, - = unimplemented, reads as '0'. Shaded cells are not used by PORTA.

Note 1: On any device RESET, these pins are configured as inputs.

PIC17C7XX

10.2 PORTB and DDRB Registers

PORTB is an 8-bit wide, bi-directional port. The corresponding data direction register is DDRB. A '1' in DDRB configures the corresponding port pin as an input. A '0' in the DDRB register configures the corresponding port pin as an output. Reading PORTB reads the status of the pins, whereas writing to PORTB will write to the port latch.

Each of the PORTB pins has a weak internal pull-up. A single control bit can turn on all the pull-ups. This is done by clearing the RBPU (PORTA<7>) bit. The weak pull-up is automatically turned off when the port pin is configured as an output. The pull-ups are enabled on any RESET.

PORTB also has an interrupt-on-change feature. Only pins configured as inputs can cause this interrupt to occur (i.e., any RB7:RB0 pin configured as an output is excluded from the interrupt-on-change comparison). The input pins (of RB7:RB0) are compared with the value in the PORTB data latch. The "mismatch" outputs of RB7:RB0 are OR'd together to set the PORTB Interrupt Flag bit, RBIF (PIR1<7>).

This interrupt can wake the device from SLEEP. The user, in the Interrupt Service Routine, can clear the interrupt by:

- Read-Write PORTB (such as: `MOVWF PORTB, PORTB`). This will end the mismatch condition.
- Then, clear the RBIF bit.

A mismatch condition will continue to set the RBIF bit. Reading, then writing PORTB, will end the mismatch condition and allow the RBIF bit to be cleared.

This interrupt-on-mismatch feature, together with software configurable pull-ups on this port, allows easy interface to a keypad and makes it possible for wake-up on key depression. For an example, refer to Application Note AN552, "Implementing Wake-up on Keystroke."

The interrupt-on-change feature is recommended for wake-up on operations, where PORTB is only used for the interrupt-on-change feature and key depression operations.

Note: On a device RESET, the RBIF bit is indeterminate, since the value in the latch may be different than the pin.

FIGURE 10-5: BLOCK DIAGRAM OF RB5:RB4 AND RB1:RB0 PORT PINS

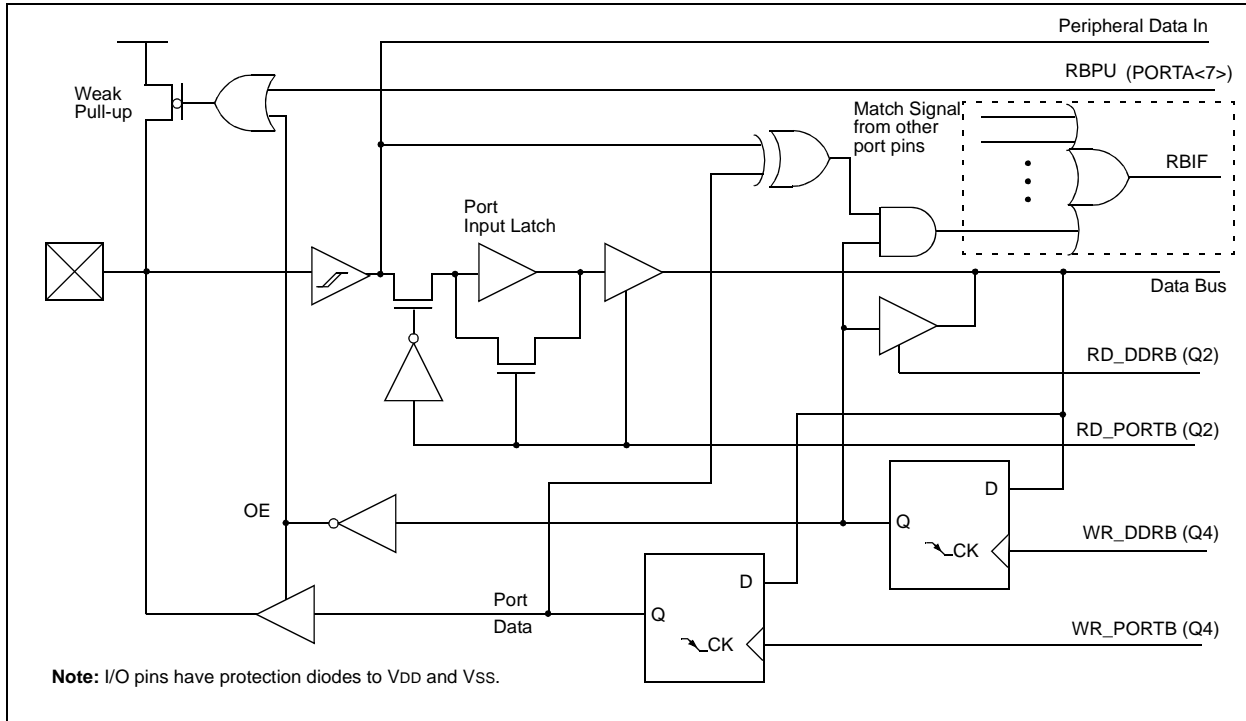

Example 10-2 shows an instruction sequence to initialize PORTB. The Bank Select Register (BSR) must be selected to Bank 0 for the port to be initialized. The following example uses the MOVLB instruction to load the BSR register for bank selection.

EXAMPLE 10-2: INITIALIZING PORTB

```

MOVLB  0      ; Select Bank 0
CLRF   PORTB, F ; Init PORTB by clearing
                ; output data latches
MOVLW  0xCF   ; Value used to initialize
                ; data direction
MOVWF  DDRB   ; Set RB<3:0> as inputs
                ; RB<5:4> as outputs
                ; RB<7:6> as inputs
    
```

FIGURE 10-6: BLOCK DIAGRAM OF RB3:RB2 PORT PINS

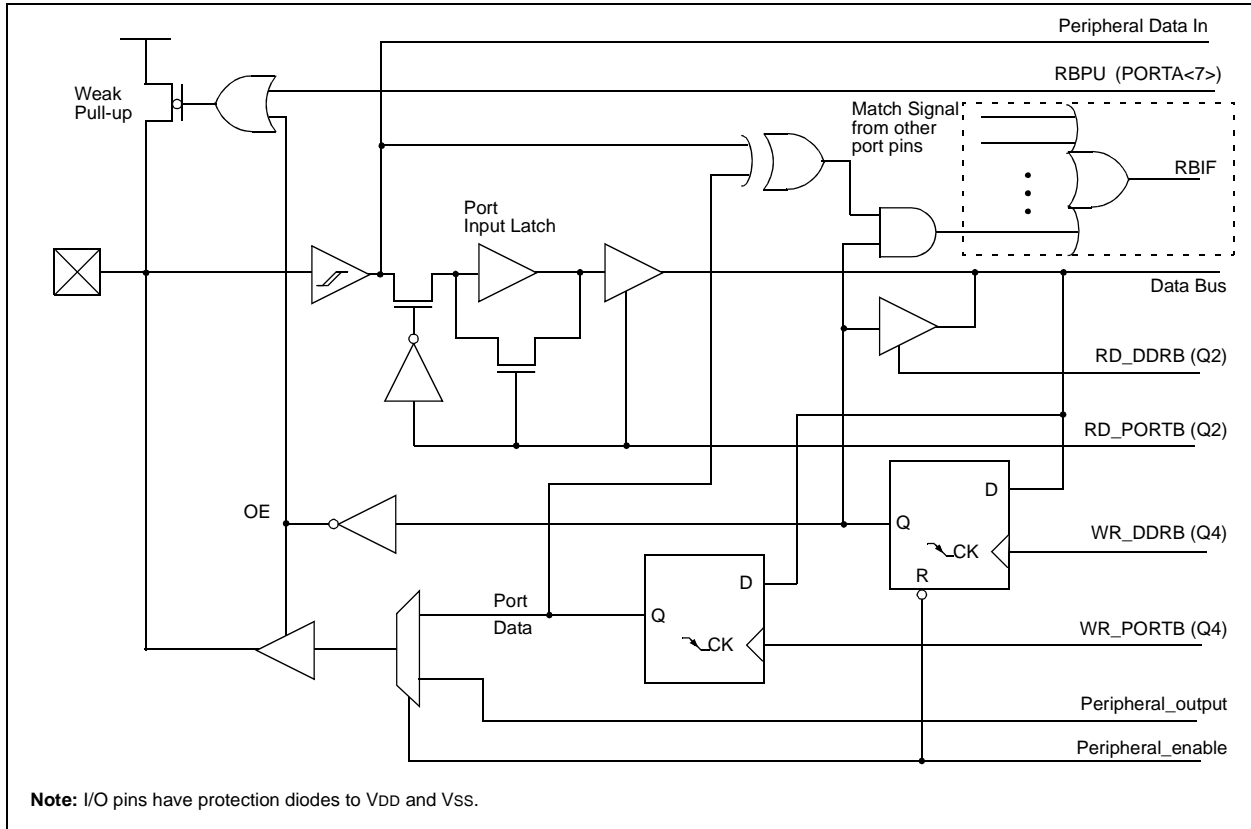

PIC17C7XX

FIGURE 10-7: BLOCK DIAGRAM OF RB6 PORT PIN

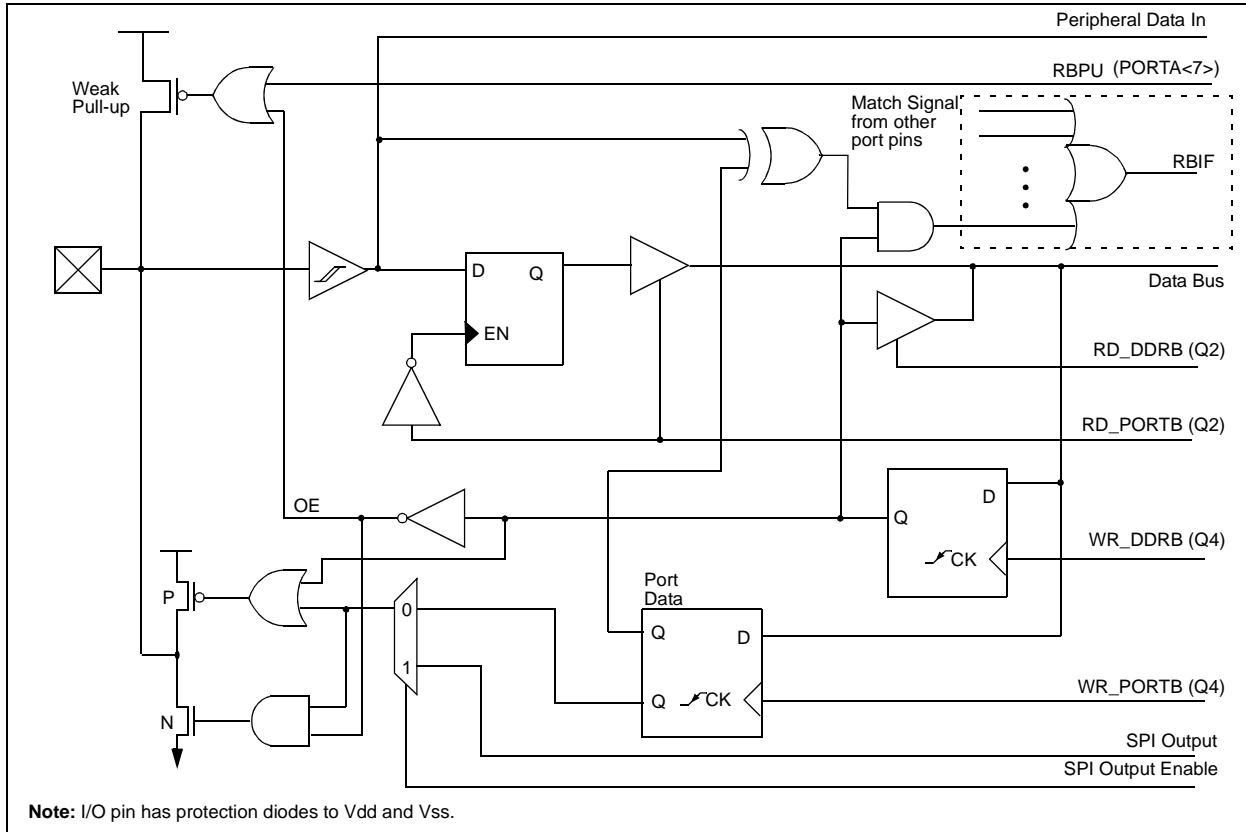

FIGURE 10-8: BLOCK DIAGRAM OF RB7 PORT PIN

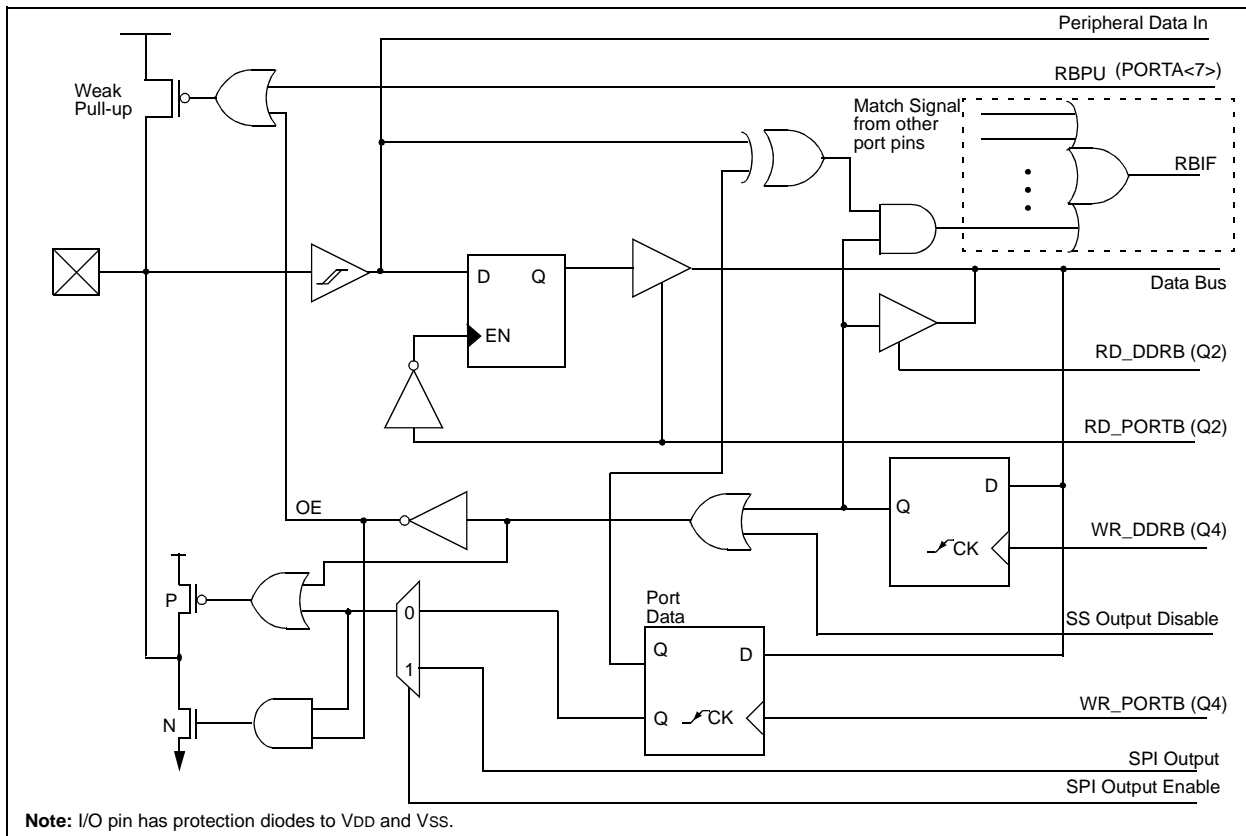

TABLE 10-3: PORTB FUNCTIONS

Name	Bit	Buffer Type	Function
RB0/CAP1	bit0	ST	Input/output or the Capture1 input pin. Software programmable weak pull-up and interrupt-on-change features.
RB1/CAP2	bit1	ST	Input/output or the Capture2 input pin. Software programmable weak pull-up and interrupt-on-change features.
RB2/PWM1	bit2	ST	Input/output or the PWM1 output pin. Software programmable weak pull-up and interrupt-on-change features.
RB3/PWM2	bit3	ST	Input/output or the PWM2 output pin. Software programmable weak pull-up and interrupt-on-change features.
RB4/TCLK12	bit4	ST	Input/output or the external clock input to Timer1 and Timer2. Software programmable weak pull-up and interrupt-on-change features.
RB5/TCLK3	bit5	ST	Input/output or the external clock input to Timer3. Software programmable weak pull-up and interrupt-on-change features.
RB6/SCK	bit6	ST	Input/output or the Master/Slave clock for the SPI. Software programmable weak pull-up and interrupt-on-change features.
RB7/SDO	bit7	ST	Input/output or data output for the SPI. Software programmable weak pull-up and interrupt-on-change features.

Legend: ST = Schmitt Trigger input

TABLE 10-4: REGISTERS/BITS ASSOCIATED WITH PORTB

Address	Name	Bit 7	Bit 6	Bit 5	Bit 4	Bit 3	Bit 2	Bit 1	Bit 0	Value on POR, BOR	MCLR, WDT
12h, Bank 0	PORTB	RB7/SDO	RB6/SCK	RB5/TCLK3	RB4/TCLK12	RB3/PWM2	RB2/PWM1	RB1/CAP2	RB0/CAP1	xxxx xxxx	uuuu uuuu
11h, Bank 0	DDRB	Data Direction Register for PORTB								1111 1111	1111 1111
10h, Bank 0	PORTA	RBP \bar{U}	—	RA5/TX1/CK1	RA4/RX1/DT1	RA3/SDI/SDA	RA2/SS/SCL	RA1/T0CKI	RA0/INT	0-xx 11xx	0-uu 11uu
06h, Unbanked	CPUSTA	—	—	STKAV	GLINTD	TO	PD	POR	BOR	--11 11qq	--11 qquu
07h, Unbanked	INTSTA	PEIF	T0CKIF	T0IF	INTF	PEIE	T0CKIE	T0IE	INTE	0000 0000	0000 0000
16h, Bank 1	PIR1	RBIF	TMR3IF	TMR2IF	TMR1IF	CA2IF	CA1IF	TX1IF	RC1IF	x000 0010	u000 0010
17h, Bank 1	PIE1	RBIE	TMR3IE	TMR2IE	TMR1IE	CA2IE	CA1IE	TX1IE	RC1IE	0000 0000	0000 0000
16h, Bank 3	TCON1	CA2ED1	CA2ED0	CA1ED1	CA1ED0	T16	TMR3CS	TMR2CS	TMR1CS	0000 0000	0000 0000
17h, Bank 3	TCON2	CA2OVF	CA1OVF	PWM2ON	PWM1ON	CA1/PR3	TMR3ON	TMR2ON	TMR1ON	0000 0000	0000 0000

Legend: x = unknown, u = unchanged, - = unimplemented, read as '0', q = value depends on condition. Shaded cells are not used by PORTB.

PIC17C7XX

10.3 PORTC and DDRC Registers

PORTC is an 8-bit bi-directional port. The corresponding data direction register is DDRC. A '1' in DDRC configures the corresponding port pin as an input. A '0' in the DDRC register configures the corresponding port pin as an output. Reading PORTC reads the status of the pins, whereas writing to PORTC will write to the port latch. PORTC is multiplexed with the system bus. When operating as the system bus, PORTC is the low order byte of the address/data bus (AD7:AD0). The timing for the system bus is shown in the Electrical Specifications section.

Note: This port is configured as the system bus when the device's configuration bits are selected to Microprocessor or Extended Microcontroller modes. In the two other microcontroller modes, this port is a general purpose I/O.

Example 10-3 shows an instruction sequence to initialize PORTC. The Bank Select Register (BSR) must be selected to Bank 1 for the port to be initialized. The following example uses the MOVLB instruction to load the BSR register for bank selection.

EXAMPLE 10-3: INITIALIZING PORTC

```

MOVLB 1      ; Select Bank 1
CLRF  PORTC, F ; Initialize PORTC data
                ; latches before setting
                ; the data direction reg
MOVLW 0xCF   ; Value used to initialize
                ; data direction
MOVWF DDRC   ; Set RC<3:0> as inputs
                ; RC<5:4> as outputs
                ; RC<7:6> as inputs
    
```

FIGURE 10-9: BLOCK DIAGRAM OF RC7:RC0 PORT PINS

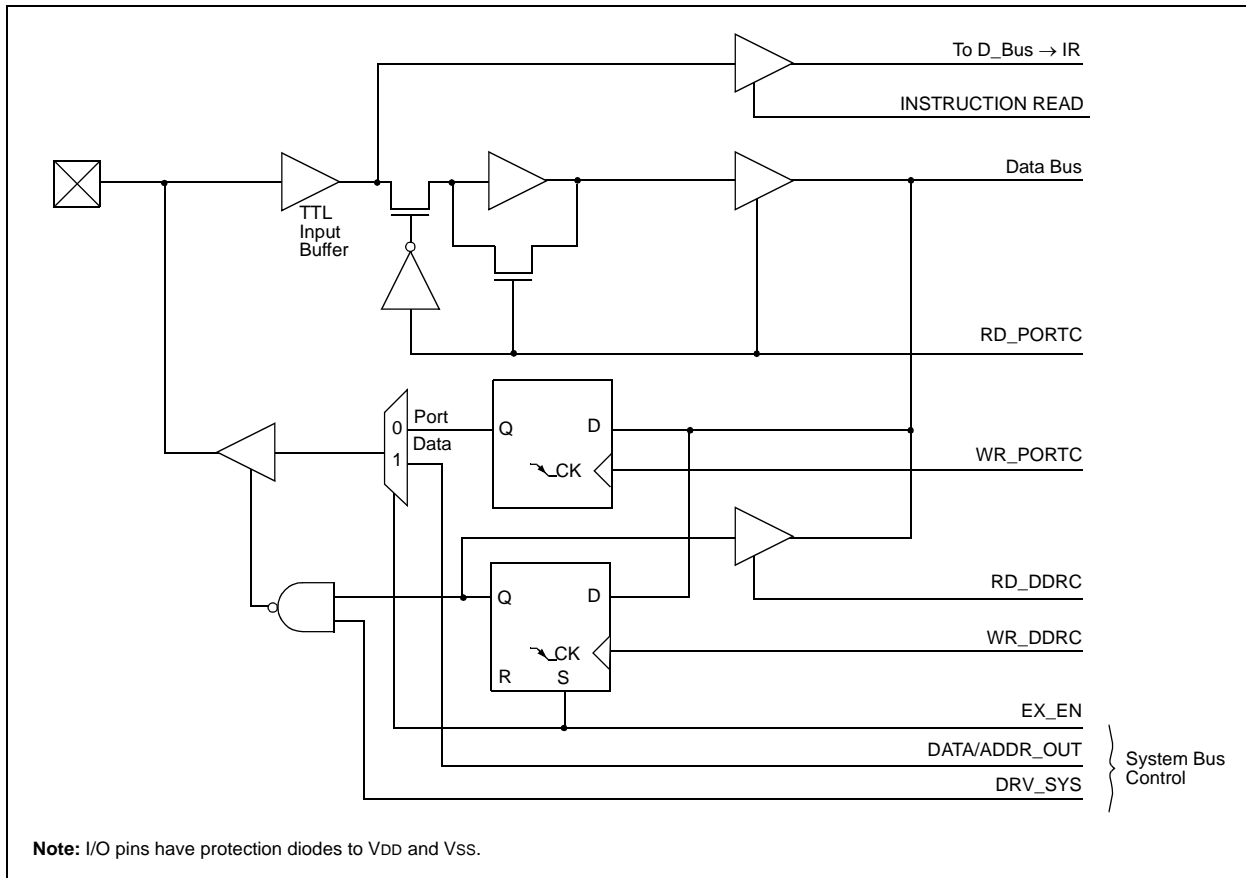

TABLE 10-5: PORTC FUNCTIONS

Name	Bit	Buffer Type	Function
RC0/AD0	bit0	TTL	Input/output or system bus address/data pin.
RC1/AD1	bit1	TTL	Input/output or system bus address/data pin.
RC2/AD2	bit2	TTL	Input/output or system bus address/data pin.
RC3/AD3	bit3	TTL	Input/output or system bus address/data pin.
RC4/AD4	bit4	TTL	Input/output or system bus address/data pin.
RC5/AD5	bit5	TTL	Input/output or system bus address/data pin.
RC6/AD6	bit6	TTL	Input/output or system bus address/data pin.
RC7/AD7	bit7	TTL	Input/output or system bus address/data pin.

Legend: TTL = TTL input

TABLE 10-6: REGISTERS/BITS ASSOCIATED WITH PORTC

Address	Name	Bit 7	Bit 6	Bit 5	Bit 4	Bit 3	Bit 2	Bit 1	Bit 0	Value on POR, BOR	MCLR, WDT
11h, Bank 1	PORTC	RC7/ AD7	RC6/ AD6	RC5/ AD5	RC4/ AD4	RC3/ AD3	RC2/ AD2	RC1/ AD1	RC0/ AD0	xxxx xxxx	uuuu uuuu
10h, Bank 1	DDRC	Data Direction Register for PORTC								1111 1111	1111 1111

Legend: x = unknown, u = unchanged

PIC17C7XX

10.4 PORTD and DDRD Registers

PORTD is an 8-bit bi-directional port. The corresponding data direction register is DDRD. A '1' in DDRD configures the corresponding port pin as an input. A '0' in the DDRD register configures the corresponding port pin as an output. Reading PORTD reads the status of the pins, whereas writing to PORTD will write to the port latch. PORTD is multiplexed with the system bus. When operating as the system bus, PORTD is the high order byte of the address/data bus (AD15:AD8). The timing for the system bus is shown in the Electrical Specifications section.

Note: This port is configured as the system bus when the device's configuration bits are selected to Microprocessor or Extended Microcontroller modes. In the two other microcontroller modes, this port is a general purpose I/O.

Example 10-4 shows an instruction sequence to initialize PORTD. The Bank Select Register (BSR) must be selected to Bank 1 for the port to be initialized. The following example uses the MOVLB instruction to load the BSR register for bank selection.

EXAMPLE 10-4: INITIALIZING PORTD

```

MOVLB 1      ; Select Bank 1
CLRFB PORTD, F ; Initialize PORTD data
                ; latches before setting
                ; the data direction reg
MOVW 0xCF    ; Value used to initialize
                ; data direction
MOVWF DDRD   ; Set RD<3:0> as inputs
                ; RD<5:4> as outputs
                ; RD<7:6> as inputs
    
```

FIGURE 10-10: BLOCK DIAGRAM OF RD7:RD0 PORT PINS (IN I/O PORT MODE)

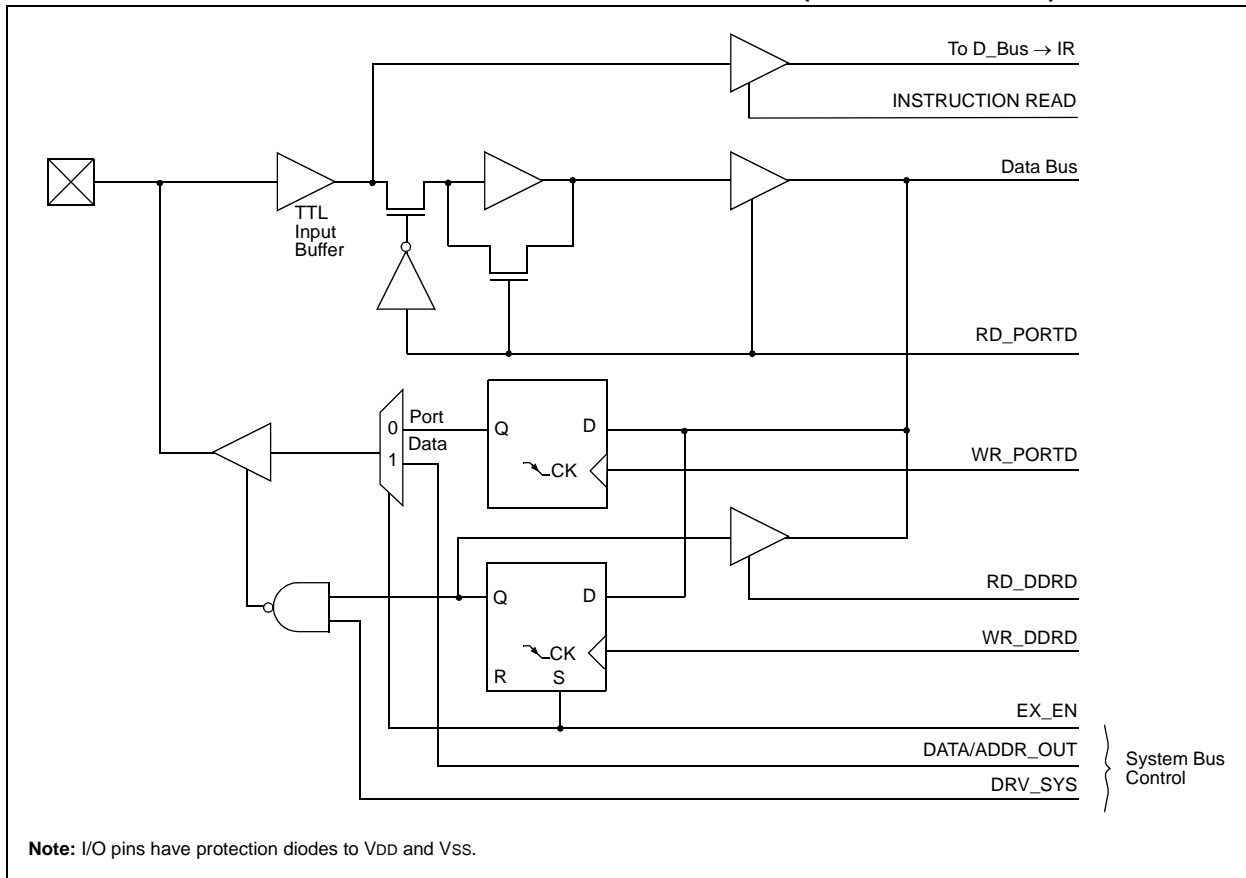

TABLE 10-7: PORTD FUNCTIONS

Name	Bit	Buffer Type	Function
RD0/AD8	bit0	TTL	Input/output or system bus address/data pin.
RD1/AD9	bit1	TTL	Input/output or system bus address/data pin.
RD2/AD10	bit2	TTL	Input/output or system bus address/data pin.
RD3/AD11	bit3	TTL	Input/output or system bus address/data pin.
RD4/AD12	bit4	TTL	Input/output or system bus address/data pin.
RD5/AD13	bit5	TTL	Input/output or system bus address/data pin.
RD6/AD14	bit6	TTL	Input/output or system bus address/data pin.
RD7/AD15	bit7	TTL	Input/output or system bus address/data pin.

Legend: TTL = TTL input

TABLE 10-8: REGISTERS/BITS ASSOCIATED WITH PORTD

Address	Name	Bit 7	Bit 6	Bit 5	Bit 4	Bit 3	Bit 2	Bit 1	Bit 0	Value on POR, BOR	MCLR, WDT
13h, Bank 1	PORTD	RD7/ AD15	RD6/ AD14	RD5/ AD13	RD4/ AD12	RD3/ AD11	RD2/ AD10	RD1/ AD9	RD0/ AD8	xxxx xxxx	uuuu uuuu
12h, Bank 1	DDRD	Data Direction Register for PORTD								1111 1111	1111 1111

Legend: x = unknown, u = unchanged

PIC17C7XX

10.5 PORTE and DDRE Register

PORTE is a 4-bit bi-directional port. The corresponding data direction register is DDRE. A '1' in DDRE configures the corresponding port pin as an input. A '0' in the DDRE register configures the corresponding port pin as an output. Reading PORTE reads the status of the pins, whereas writing to PORTE will write to the port latch. PORTE is multiplexed with the system bus. When operating as the system bus, PORTE contains the control signals for the address/data bus (AD15:AD0). These control signals are Address Latch Enable (ALE), Output Enable (\overline{OE}) and Write (\overline{WR}). The control signals \overline{OE} and \overline{WR} are active low signals. The timing for the system bus is shown in the Electrical Specifications section.

Note: Three pins of this port are configured as the system bus when the device's configuration bits are selected to Microprocessor or Extended Microcontroller modes. The other pin is a general purpose I/O or Capture4 pin. In the two other microcontroller modes, RE2:RE0 are general purpose I/O pins.

Example 10-5 shows an instruction sequence to initialize PORTE. The Bank Select Register (BSR) must be selected to Bank 1 for the port to be initialized. The following example uses the MOVLB instruction to load the BSR register for bank selection.

EXAMPLE 10-5: INITIALIZING PORTE

```

MOVLB  1      ; Select Bank 1
CLRFB  PORTE, F ; Initialize PORTE data
                ; latches before setting
                ; the data direction
                ; register
MOVLW   0x03   ; Value used to initialize
                ; data direction
MOVWF  DDRE    ; Set RE<1:0> as inputs
                ; RE<3:2> as outputs
                ; RE<7:4> are always
                ; read as '0'
    
```

FIGURE 10-11: BLOCK DIAGRAM OF RE2:RE0 (IN I/O PORT MODE)

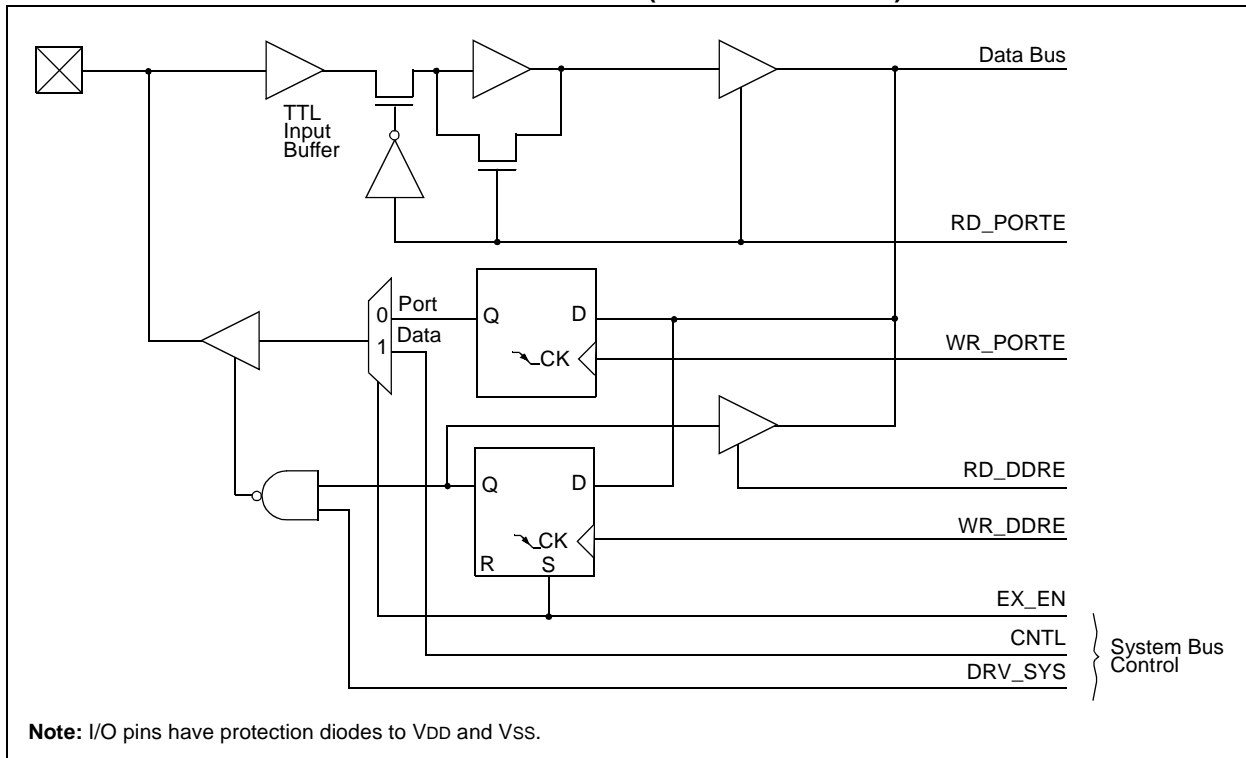

FIGURE 10-12: BLOCK DIAGRAM OF RE3/CAP4 PORT PIN

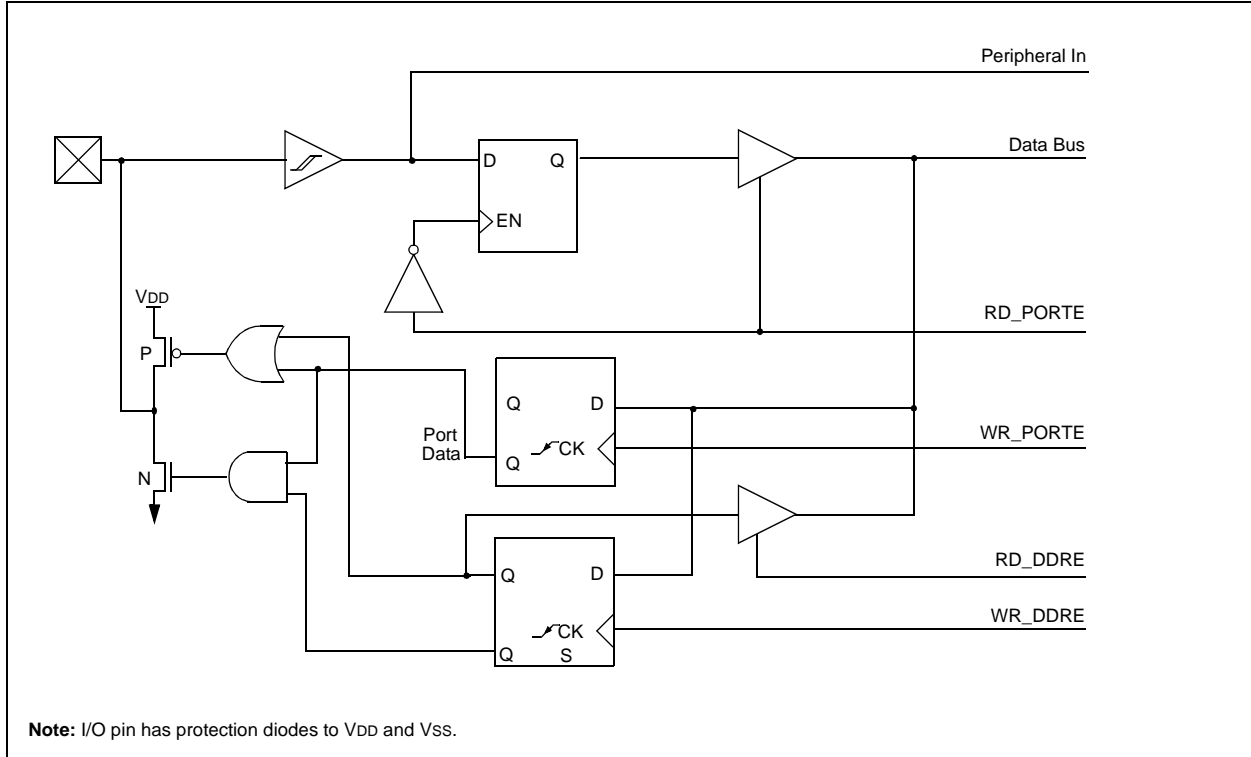

TABLE 10-9: PORTE FUNCTIONS

Name	Bit	Buffer Type	Function
RE0/ALE	bit0	TTL	Input/output or system bus Address Latch Enable (ALE) control pin.
RE1/OE	bit1	TTL	Input/output or system bus Output Enable (OE) control pin.
RE2/WR	bit2	TTL	Input/output or system bus Write (WR) control pin.
RE3/CAP4	bit3	ST	Input/output or Capture4 input pin.

Legend: TTL = TTL input, ST = Schmitt Trigger input

TABLE 10-10: REGISTERS/BITS ASSOCIATED WITH PORTE

Address	Name	Bit 7	Bit 6	Bit 5	Bit 4	Bit 3	Bit 2	Bit 1	Bit 0	Value on POR, BOR	MCLR, WDT
15h, Bank 1	PORTE	—	—	—	—	RE3/CAP4	RE2/WR	RE1/OE	RE0/ALE	---- xxxx	---- uuuu
14h, Bank 1	DDRE	Data Direction Register for PORTE								---- 1111	---- 1111
14h, Bank 7	CA4L	Capture4 Low Byte								xxxx xxxx	uuuu uuuu
15h, Bank 7	CA4H	Capture4 High Byte								xxxx xxxx	uuuu uuuu
16h, Bank 7	TCON3	—	CA4OVF	CA3OVF	CA4ED1	CA4ED0	CA3ED1	CA3ED0	PWM3ON	-000 0000	-000 0000

Legend: x = unknown, u = unchanged, - = unimplemented, read as '0'. Shaded cells are not used by PORTE.

PIC17C7XX

10.6 PORTF and DDRF Registers

PORTF is an 8-bit wide bi-directional port. The corresponding data direction register is DDRF. A '1' in DDRF configures the corresponding port pin as an input. A '0' in the DDRF register configures the corresponding port pin as an output. Reading PORTF reads the status of the pins, whereas writing to PORTF will write to the respective port latch.

All eight bits of PORTF are multiplexed with 8 channels of the 10-bit A/D converter.

Upon RESET, the entire Port is automatically configured as analog inputs and must be configured in software to be a digital I/O.

Example 10-6 shows an instruction sequence to initialize PORTF. The Bank Select Register (BSR) must be selected to Bank 5 for the port to be initialized. The following example uses the MOVLB instruction to load the BSR register for bank selection.

EXAMPLE 10-6: INITIALIZING PORTF

```

MOVLB 5      ; Select Bank 5
MOVWF 0x0E   ; Configure PORTF as
MOVWF ADCON1 ; Digital
CLRF PORTF, F ; Initialize PORTF data
              ; latches before
              ; the data direction
              ; register
MOVLW 0x03   ; Value used to init
              ; data direction
MOVWF DDRF   ; Set RF<1:0> as inputs
              ; RF<7:2> as outputs
    
```

FIGURE 10-13: BLOCK DIAGRAM OF RF7:RF0

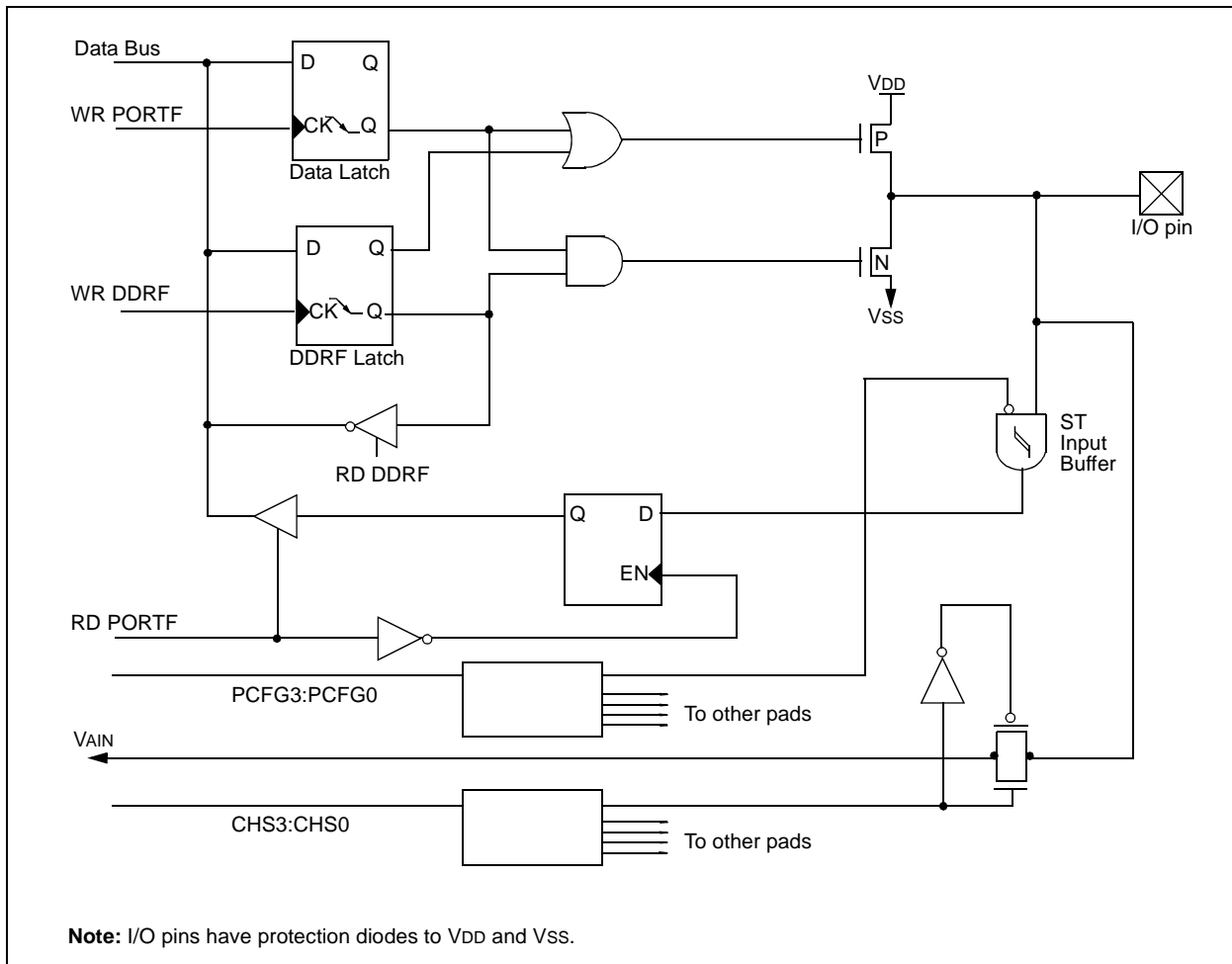

TABLE 10-11: PORTF FUNCTIONS

Name	Bit	Buffer Type	Function
RF0/AN4	bit0	ST	Input/output or analog input 4.
RF1/AN5	bit1	ST	Input/output or analog input 5.
RF2/AN6	bit2	ST	Input/output or analog input 6.
RF3/AN7	bit3	ST	Input/output or analog input 7.
RF4/AN8	bit4	ST	Input/output or analog input 8.
RF5/AN9	bit5	ST	Input/output or analog input 9.
RF6/AN10	bit6	ST	Input/output or analog input 10.
RF7/AN11	bit7	ST	Input/output or analog input 11.

Legend: ST = Schmitt Trigger input

TABLE 10-12: REGISTERS/BITS ASSOCIATED WITH PORTF

Address	Name	Bit 7	Bit 6	Bit 5	Bit 4	Bit 3	Bit 2	Bit 1	Bit 0	Value on POR, BOR	MCLR, WDT
10h, Bank 5	DDRF	Data Direction Register for PORTF								1111 1111	1111 1111
11h, Bank 5	PORTF	RF7/ AN11	RF6/ AN10	RF5/ AN9	RF4/ AN8	RF3/ AN7	RF2/ AN6	RF1/ AN5	RF0/ AN4	0000 0000	0000 0000
15h, Bank 5	ADCON1	ADCS1	ADCS0	ADFM	—	PCFG3	PCFG2	PCFG1	PCFG0	000- 0000	000- 0000

Legend: x = unknown, u = unchanged, - = unimplemented, read as '0'. Shaded cells are not used by PORTF.

PIC17C7XX

10.7 PORTG and DDRG Registers

PORTG is an 8-bit wide, bi-directional port. The corresponding data direction register is DDRG. A '1' in DDRG configures the corresponding port pin as an input. A '0' in the DDRG register configures the corresponding port pin as an output. Reading PORTG reads the status of the pins, whereas writing to PORTG will write to the port latch.

The lower four bits of PORTG are multiplexed with four channels of the 10-bit A/D converter.

The remaining bits of PORTG are multiplexed with peripheral output and inputs. RG4 is multiplexed with the CAP3 input, RG5 is multiplexed with the PWM3 output, RG6 and RG7 are multiplexed with the USART2 functions.

Upon RESET, RG3:RG0 is automatically configured as analog inputs and must be configured in software to be a digital I/O.

Example 10-7 shows the instruction sequence to initialize PORTG. The Bank Select Register (BSR) must be selected to Bank 5 for the port to be initialized. The following example uses the MOVLB instruction to load the BSR register for bank selection.

EXAMPLE 10-7: INITIALIZING PORTG

```

MOVLB 5           ; Select Bank 5
MOVLW 0x0E        ; Configure PORTG as
MOVFPF WREG, ADCON1 ; digital
CLRF PORTG, F     ; Initialize PORTG data
                  ; latches before
                  ; the data direction
                  ; register
MOVLW 0x03        ; Value used to init
                  ; data direction
MOVWF DDRG        ; Set RG<1:0> as inputs
                  ; RG<7:2> as outputs
    
```

FIGURE 10-14: BLOCK DIAGRAM OF RG3:RG0

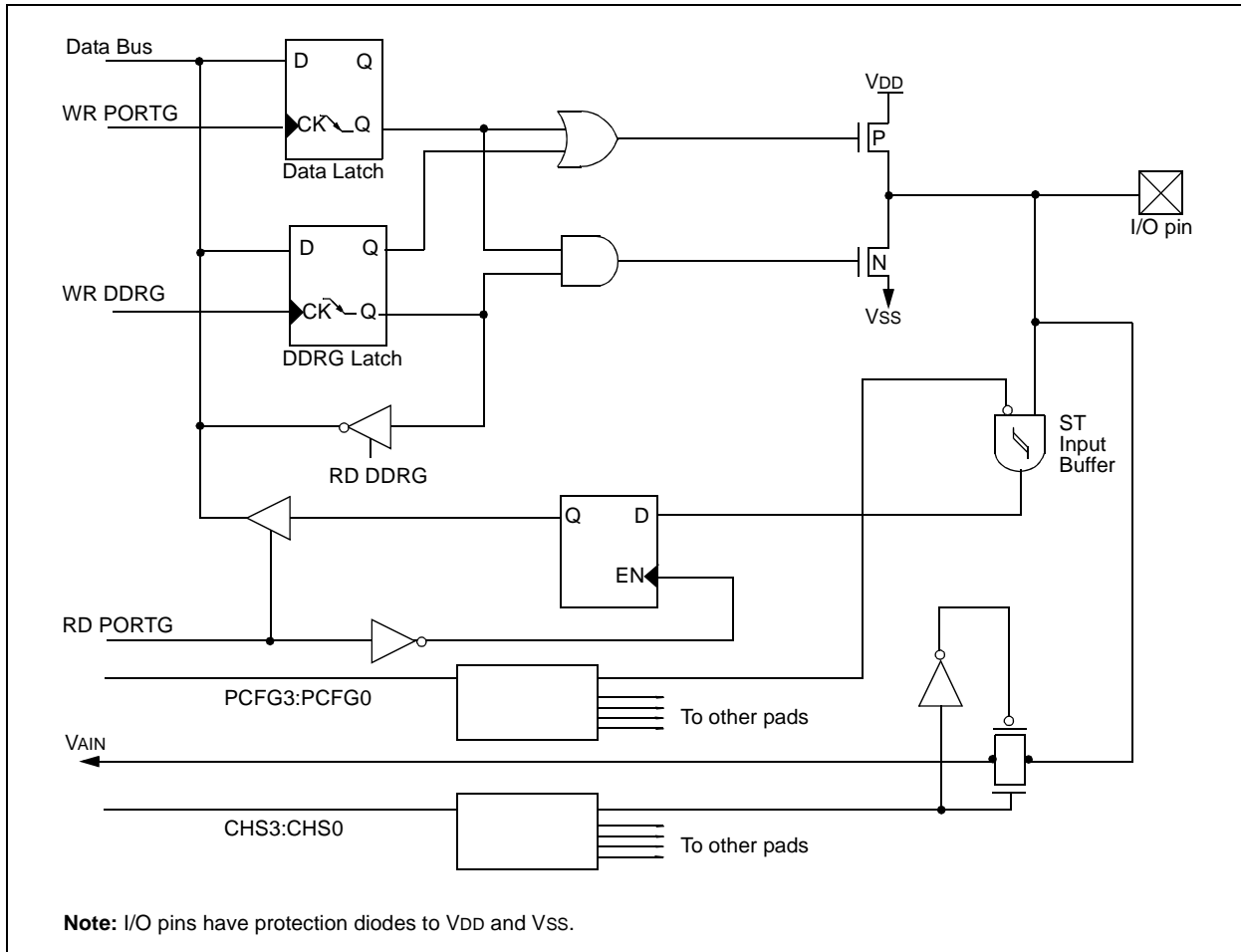

PIC17C7XX

TABLE 10-13: PORTG FUNCTIONS

Name	Bit	Buffer Type	Function
RG0/AN3	bit0	ST	Input/output or analog input 3.
RG1/AN2	bit1	ST	Input/output or analog input 2.
RG2/AN1/VREF-	bit2	ST	Input/output or analog input 1 or the ground reference voltage.
RG3/AN0/VREF+	bit3	ST	Input/output or analog input 0 or the positive reference voltage.
RG4/CAP3	bit4	ST	Input/output or the Capture3 input pin.
RG5/PWM3	bit5	ST	Input/output or the PWM3 output pin.
RG6/RX2/DT2	bit6	ST	Input/output or the USART2 (SCI) Asynchronous Receive or USART2 (SCI) Synchronous Data.
RG7/TX2/CK2	bit7	ST	Input/output or the USART2 (SCI) Asynchronous Transmit or USART2 (SCI) Synchronous Clock.

Legend: ST = Schmitt Trigger input

TABLE 10-14: REGISTERS/BITS ASSOCIATED WITH PORTG

Address	Name	Bit 7	Bit 6	Bit 5	Bit 4	Bit 3	Bit 2	Bit 1	Bit 0	Value on POR, BOR	MCLR, WDT
12h, Bank 5	DDRG	Data Direction Register for PORTG								1111 1111	1111 1111
13h, Bank 5	PORTG	RG7/ TX2/CK2	RG6/ RX2/DT2	RG5/ PWM3	RG4/ CAP3	RG3/ AN0	RG2/ AN1	RG1/ AN2	RG0/ AN3	xxxx 0000	uuuu 0000
15h, Bank 5	ADCON1	ADCS1	ADCS0	ADFM	—	PCFG3	PCFG2	PCFG1	PCFG0	000- 0000	000- 0000

Legend: x = unknown, u = unchanged, - = unimplemented, read as '0'. Shaded cells are not used by PORTG.

10.8 PORTH and DDRH Registers (PIC17C76X only)

PORTH is an 8-bit wide, bi-directional port. The corresponding data direction register is DDRH. A '1' in DDRH configures the corresponding port pin as an input. A '0' in the DDRH register configures the corresponding port pin as an output. Reading PORTH reads the status of the pins, whereas writing to PORTH will write to the respective port latch.

The upper four bits of PORTH are multiplexed with 4 channels of the 10-bit A/D converter.

The remaining bits of PORTH are general purpose I/O.

Upon RESET, RH7:RH4 are automatically configured as analog inputs and must be configured in software to be a digital I/O.

EXAMPLE 10-8: INITIALIZING PORTH

```

MOVLB  8      ; Select Bank 8
MOVLW  0x0E   ; Configure PORTH as
MOVVPF ADCON1 ; digital
CLRF   PORTH, F ; Initialize PORTH data
                ; latches before
                ; the data direction
                ; register
MOVLW  0x03   ; Value used to init
MOVWF  DDRH   ; Set RH<1:0> as inputs
                ; RH<7:2> as outputs
    
```

FIGURE 10-17: BLOCK DIAGRAM OF RH7:RH4

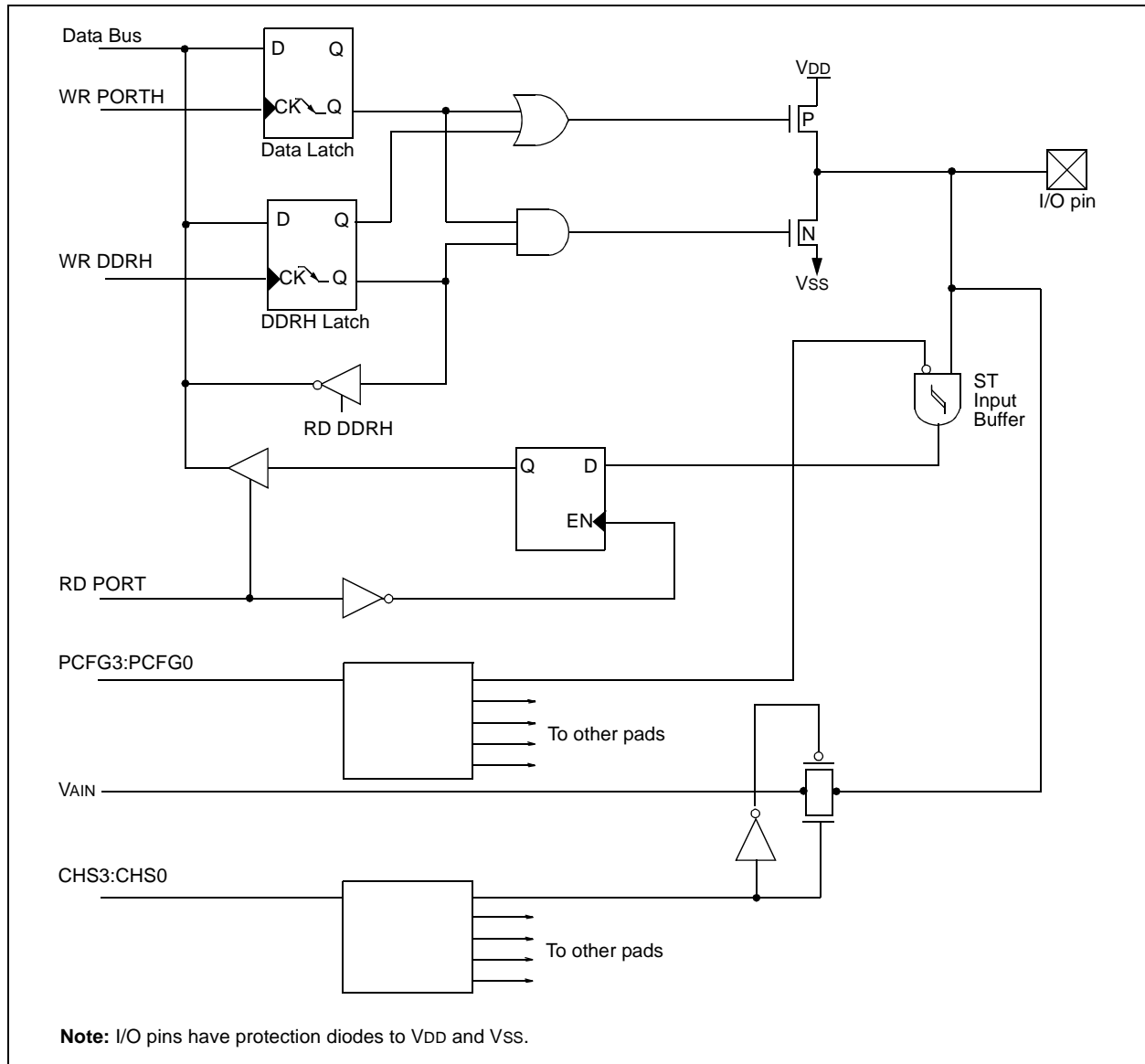

PIC17C7XX

FIGURE 10-18: RH3:RH0 BLOCK DIAGRAM

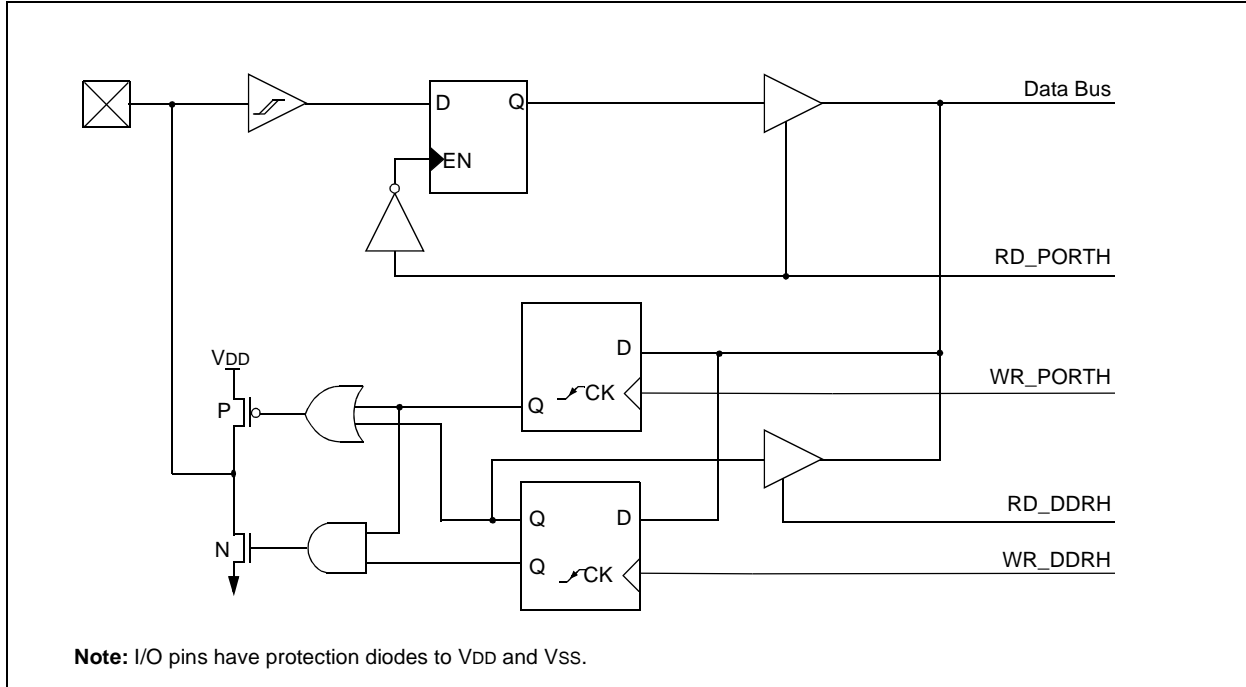

TABLE 10-15: PORTH FUNCTIONS

Name	Bit	Buffer Type	Function
RH0	bit0	ST	Input/output.
RH1	bit1	ST	Input/output.
RH2	bit2	ST	Input/output.
RH3	bit3	ST	Input/output.
RH4/AN12	bit4	ST	Input/output or analog input 12.
RH5/AN13	bit5	ST	Input/output or analog input 13.
RH6/AN14	bit6	ST	Input/output or analog input 14.
RH7/AN15	bit7	ST	Input/output or analog input 15.

Legend: ST = Schmitt Trigger input

TABLE 10-16: REGISTERS/BITS ASSOCIATED WITH PORTH

Address	Name	Bit 7	Bit 6	Bit 5	Bit 4	Bit 3	Bit 2	Bit 1	Bit 0	Value on POR, BOR	MCLR, WDT
10h, Bank 8	DDRH	Data Direction Register for PORTH								1111 1111	1111 1111
11h, Bank 8	PORTH	RH7/ AN15	RH6/ AN14	RH5/ AN13	RH4/ AN12	RH3	RH2	RH1	RH0	0000 xxxxx	0000 uuuu
15h, Bank 5	ADCON1	ADCS1	ADCS0	ADFM	—	PCFG3	PCFG2	PCFG1	PCFG0	000- 0000	000- 0000

Legend: x = unknown, u = unchanged

10.9 PORTJ and DDRJ Registers (PIC17C76X only)

PORTJ is an 8-bit wide, bi-directional port. The corresponding data direction register is DDRJ. A '1' in DDRJ configures the corresponding port pin as an input. A '0' in the DDRJ register configures the corresponding port pin as an output. Reading PORTJ reads the status of the pins, whereas writing to PORTJ will write to the respective port latch.

PORTJ is a general purpose I/O port.

EXAMPLE 10-9: INITIALIZING PORTJ

```

MOVLB  8      ; Select Bank 8
CLRWF  PORTJ, F ; Initialize PORTJ data
                ; latches before setting
                ; the data direction
                ; register
MOVLW   0xCF   ; Value used to initialize
                ; data direction
MOVWF  DDRJ    ; Set RJ<3:0> as inputs
                ; RJ<5:4> as outputs
                ; RJ<7:6> as inputs
    
```

FIGURE 10-19: PORTJ BLOCK DIAGRAM

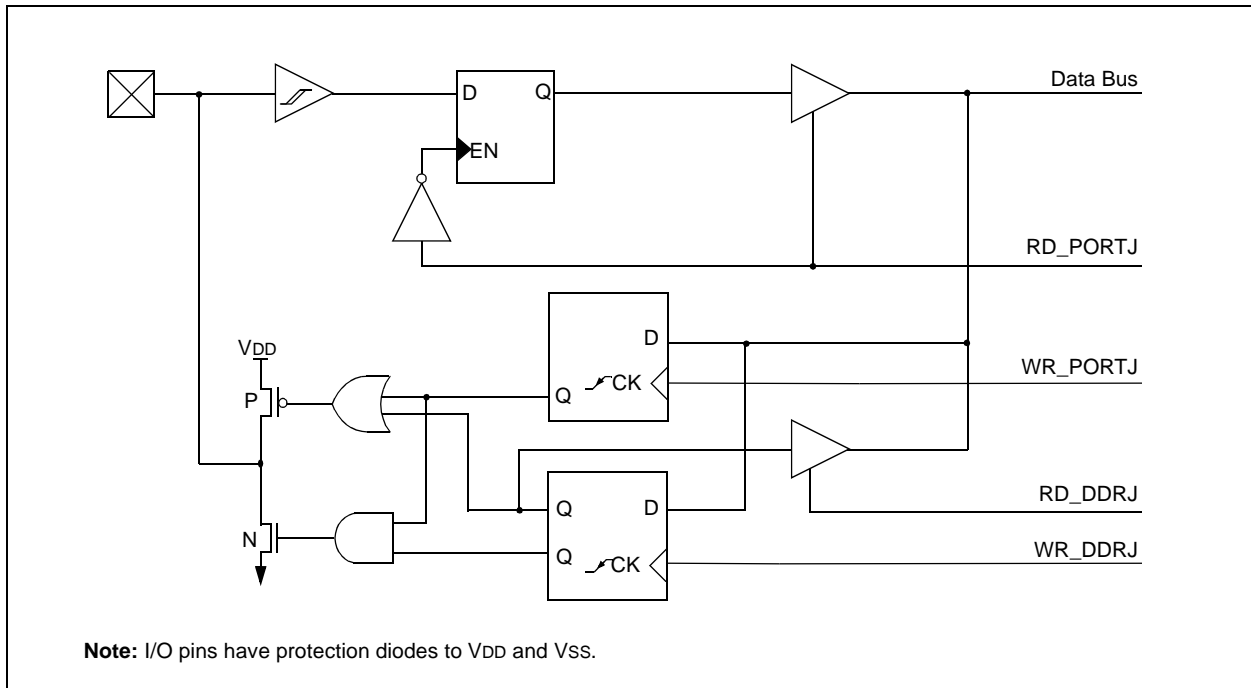

PIC17C7XX

TABLE 10-17: PORTJ FUNCTIONS

Name	Bit	Buffer Type	Function
RJ0	bit0	ST	Input/output
RJ1	bit1	ST	Input/output
RJ2	bit2	ST	Input/output
RJ3	bit3	ST	Input/output
RJ4	bit4	ST	Input/output
RJ5	bit5	ST	Input/output
RJ6	bit6	ST	Input/output
RJ7	bit7	ST	Input/output

Legend: ST = Schmitt Trigger input

TABLE 10-18: REGISTERS/BITS ASSOCIATED WITH PORTJ

Address	Name	Bit 7	Bit 6	Bit 5	Bit 4	Bit 3	Bit 2	Bit 1	Bit 0	Value on, POR, BOR	$\overline{\text{MCLR}}$, WDT
12h, Bank 8	DDRJ	Data Direction Register for PORTJ								1111 1111	1111 1111
13h, Bank 8	PORTJ	RJ7	RJ6	RJ5	RJ4	RJ3	RJ2	RJ1	RJ0	xxxx xxxx	uuuu uuuu

Legend: x = unknown, u = unchanged

10.10 I/O Programming Considerations

10.10.1 BI-DIRECTIONAL I/O PORTS

Any instruction which writes, operates internally as a read, followed by a write operation. For example, the `BCF` and `BSF` instructions read the register into the CPU, execute the bit operation and write the result back to the register. Caution must be used when these instructions are applied to a port with both inputs and outputs defined. For example, a `BSF` operation on bit5 of `PORTB`, will cause all eight bits of `PORTB` to be read into the CPU. Then the `BSF` operation takes place on bit5 and `PORTB` is written to the output latches. If another bit of `PORTB` is used as a bi-directional I/O pin (e.g. bit0) and it is defined as an input at this time, the input signal present on the pin itself would be read into the CPU and rewritten to the data latch of this particular pin, overwriting the previous content. As long as the pin stays in the input mode, no problem occurs. However, if bit0 is switched into output mode later on, the content of the data latch may now be unknown.

Reading a port reads the values of the port pins. Writing to the port register writes the value to the port latch. When using read-modify-write instructions (`BCF`, `BSF`, `BTG`, etc.) on a port, the value of the port pins is read, the desired operation is performed with this value and the value is then written to the port latch.

Example 10-10 shows the possible effect of two sequential read-modify-write instructions on an I/O port.

EXAMPLE 10-10: READ-MODIFY-WRITE INSTRUCTIONS ON AN I/O PORT

```

; Initial PORT settings: PORTB<7:4> Inputs
;                          PORTB<3:0> Outputs
; PORTB<7:6> have pull-ups and are
; not connected to other circuitry
;
;                          PORT latch  PORT pins
;                          -----
;
; BCF  PORTB, 7   ; 01pp pppp   11pp pppp
; BCF  PORTB, 6   ; 10pp pppp   11pp pppp
;
; BCF  DDRB, 7   ; 10pp pppp   11pp pppp
; BCF  DDRB, 6   ; 10pp pppp   10pp pppp
;
; Note that the user may have expected the
; pin values to be 00pp pppp. The 2nd BCF
; caused RB7 to be latched as the pin value
; (High).

```

Note: A pin actively outputting a Low or High should not be driven from external devices, in order to change the level on this pin (i.e., “wired-or”, “wired-and”). The resulting high output currents may damage the device.

PIC17C7XX

10.10.2 SUCCESSIVE OPERATIONS ON I/O PORTS

The actual write to an I/O port happens at the end of an instruction cycle, whereas for reading, the data must be valid at the beginning of the instruction cycle (Figure 10-20). Therefore, care must be exercised if a write followed by a read operation is carried out on the same I/O port. The sequence of instructions should be such to allow the pin voltage to stabilize (load dependent) before executing the instruction that reads the values on that I/O port. Otherwise, the previous state of that pin may be read into the CPU, rather than the “new” state. When in doubt, it is better to separate these instructions with a NOP, or another instruction not accessing this I/O port.

Figure 10-21 shows the I/O model which causes this situation. As the effective capacitance (C) becomes larger, the rise/fall time of the I/O pin increases. As the device frequency increases, or the effective capacitance increases, the possibility of this subsequent PORTx read-modify-write instruction issue increases. This effective capacitance includes the effects of the board traces.

The best way to address this is to add a series resistor at the I/O pin. This resistor allows the I/O pin to get to the desired level before the next instruction.

The use of NOP instructions between the subsequent PORTx read-modify-write instructions, is a lower cost solution, but has the issue that the number of NOP instructions is dependent on the effective capacitance C and the frequency of the device.

FIGURE 10-20: SUCCESSIVE I/O OPERATION

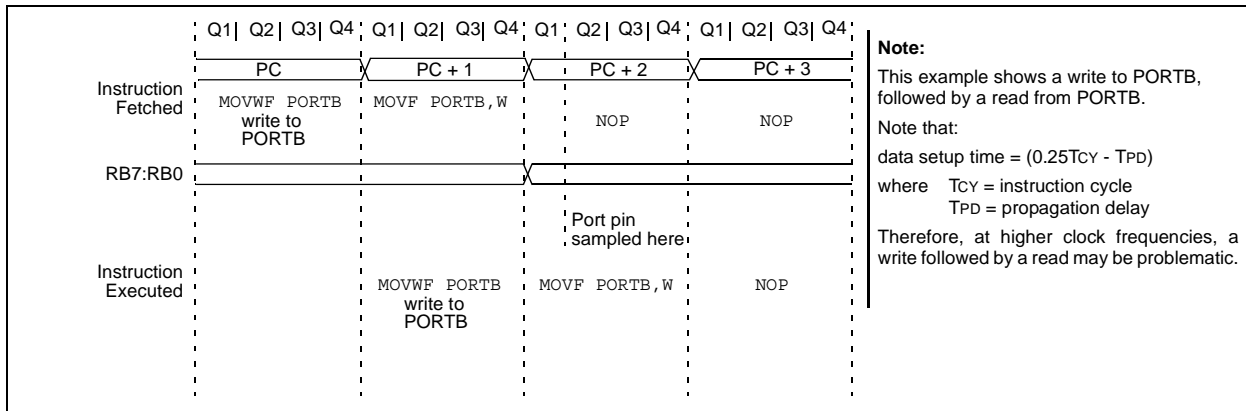
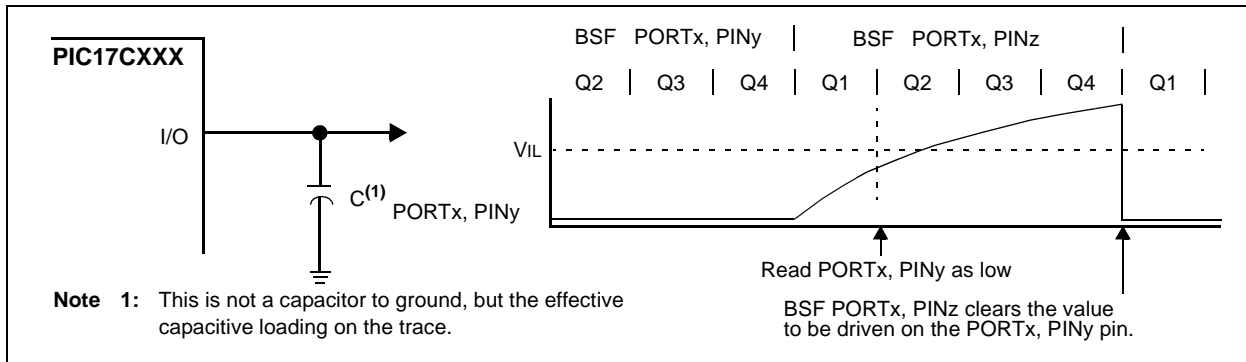

FIGURE 10-21: I/O CONNECTION ISSUES



11.0 OVERVIEW OF TIMER RESOURCES

The PIC17C7XX has four timer modules. Each module can generate an interrupt to indicate that an event has occurred. These timers are called:

- Timer0 - 16-bit timer with programmable 8-bit prescaler
- Timer1 - 8-bit timer
- Timer2 - 8-bit timer
- Timer3 - 16-bit timer

For enhanced time base functionality, four input Captures and three Pulse Width Modulation (PWM) outputs are possible. The PWMs use the Timer1 and Timer2 resources and the input Captures use the Timer3 resource.

11.1 Timer0 Overview

The Timer0 module is a simple 16-bit overflow counter. The clock source can be either the internal system clock ($F_{osc}/4$) or an external clock.

When Timer0 uses an external clock source, it has the flexibility to allow user selection of the incrementing edge, rising or falling.

The Timer0 module also has a programmable prescaler. The T0PS3:T0PS0 bits (T0STA<4:1>) determine the prescale value. TMR0 can increment at the following rates: 1:1, 1:2, 1:4, 1:8, 1:16, 1:32, 1:64, 1:128, 1:256.

Synchronization of the external clock occurs after the prescaler. When the prescaler is used, the external clock frequency may be higher than the device's frequency. The maximum external frequency on the T0CKI pin is 50 MHz, given the high and low time requirements of the clock.

11.2 Timer1 Overview

The Timer1 module is an 8-bit timer/counter with an 8-bit period register (PR1). When the TMR1 value rolls over from the period match value to 0h, the TMR1IF flag is set and an interrupt will be generated if enabled. In Counter mode, the clock comes from the RB4/TCLK12 pin, which can also be selected to be the clock for the Timer2 module.

TMR1 can be concatenated with TMR2 to form a 16-bit timer. The TMR1 register is the LSB and TMR2 is the MSB. When in the 16-bit timer mode, there is a corresponding 16-bit period register (PR2:PR1). When the TMR2:TMR1 value rolls over from the period match value to 0h, the TMR1IF flag is set and an interrupt will be generated, if enabled.

11.3 Timer2 Overview

The Timer2 module is an 8-bit timer/counter with an 8-bit period register (PR2). When the TMR2 value rolls over from the period match value to 0h, the TMR2IF flag is set and an interrupt will be generated, if enabled. In Counter mode, the clock comes from the RB4/TCLK12 pin, which can also provide the clock for the Timer1 module.

TMR2 can be concatenated with TMR1 to form a 16-bit timer. The TMR2 register is the MSB and TMR1 is the LSB. When in the 16-bit timer mode, there is a corresponding 16-bit period register (PR2:PR1). When the TMR2:TMR1 value rolls over from the period match value to 0h, the TMR1IF flag is set and an interrupt will be generated, if enabled.

11.4 Timer3 Overview

The Timer3 module is a 16-bit timer/counter with a 16-bit period register. When the TMR3H:TMR3L value rolls over to 0h, the TMR3IF bit is set and an interrupt will be generated, if enabled. In Counter mode, the clock comes from the RB5/TCLK3 pin.

When operating in the four Capture modes, the period registers become the second (of four) 16-bit capture registers.

11.5 Role of the Timer/Counters

The timer modules are general purpose, but have dedicated resources associated with them. Timer1 and Timer2 are the time bases for the three Pulse Width Modulation (PWM) outputs, while Timer3 is the time base for the four input captures.

PIC17C7XX

NOTES:

12.0 TIMER0

The Timer0 module consists of a 16-bit timer/counter, TMR0. The high byte is register TMR0H and the low byte is register TMR0L. A software programmable 8-bit prescaler makes Timer0 an effective 24-bit overflow timer. The clock source is software programmable as either the internal instruction clock, or an external clock on the RA1/T0CKI pin. The control bits for this module are in register T0STA (Figure 12-1).

REGISTER 12-1: T0STA REGISTER (ADDRESS: 05h, UNBANKED)

R/W-0	R/W-0	R/W-0	R/W-0	R/W-0	R/W-0	R/W-0	U-0
INTEDG	T0SE	T0CS	T0PS3	T0PS2	T0PS1	T0PS0	—
bit 7							bit 0

- bit 7 **INTEDG:** RA0/INT Pin Interrupt Edge Select bit
This bit selects the edge upon which the interrupt is detected.
1 = Rising edge of RA0/INT pin generates interrupt
0 = Falling edge of RA0/INT pin generates interrupt
- bit 6 **T0SE:** Timer0 Clock Input Edge Select bit
This bit selects the edge upon which TMR0 will increment.
When T0CS = 0 (External Clock):
1 = Rising edge of RA1/T0CKI pin increments TMR0 and/or sets the T0CKIF bit
0 = Falling edge of RA1/T0CKI pin increments TMR0 and/or sets the T0CKIF bit
When T0CS = 1 (Internal Clock):
Don't care
- bit 5 **T0CS:** Timer0 Clock Source Select bit
This bit selects the clock source for TMR0.
1 = Internal instruction clock cycle (Tcy)
0 = External clock input on the T0CKI pin
- bit 4-1 **T0PS3:T0PS0:** Timer0 Prescale Selection bits
These bits select the prescale value for TMR0.
- | T0PS3:T0PS0 | Prescale Value |
|-------------|----------------|
| 0000 | 1:1 |
| 0001 | 1:2 |
| 0010 | 1:4 |
| 0011 | 1:8 |
| 0100 | 1:16 |
| 0101 | 1:32 |
| 0110 | 1:64 |
| 0111 | 1:128 |
| 1xxx | 1:256 |
- bit 0 **Unimplemented:** Read as '0'

Legend:

R = Readable bit	W = Writable bit	U = Unimplemented bit, read as '0'
- n = Value at POR Reset	'1' = Bit is set	'0' = Bit is cleared x = Bit is unknown

PIC17C7XX

12.1 Timer0 Operation

When the T0CS (T0STA<5>) bit is set, TMR0 increments on the internal clock. When T0CS is clear, TMR0 increments on the external clock (RA1/T0CKI pin). The external clock edge can be selected in software. When the T0SE (T0STA<6>) bit is set, the timer will increment on the rising edge of the RA1/T0CKI pin. When T0SE is clear, the timer will increment on the falling edge of the RA1/T0CKI pin. The prescaler can be programmed to introduce a prescale of 1:1 to 1:256. The timer increments from 0000h to FFFFh and rolls over to 0000h. On overflow, the TMR0 Interrupt Flag bit (T0IF) is set. The TMR0 interrupt can be masked by clearing the corresponding TMR0 Interrupt Enable bit (T0IE). The TMR0 Interrupt Flag bit (T0IF) is automatically cleared when vectoring to the TMR0 interrupt vector.

12.2 Using Timer0 with External Clock

When an external clock input is used for Timer0, it is synchronized with the internal phase clocks. Figure 12-2 shows the synchronization of the external clock. This synchronization is done after the prescaler. The output of the prescaler (PSOUT) is sampled twice in every instruction cycle to detect a rising or a falling edge. The timing requirements for the external clock are detailed in the electrical specification section.

12.2.1 DELAY FROM EXTERNAL CLOCK EDGE

Since the prescaler output is synchronized with the internal clocks, there is a small delay from the time the external clock edge occurs to the time TMR0 is actually incremented. Figure 12-2 shows that this delay is between $3T_{osc}$ and $7T_{osc}$. Thus, for example, measuring the interval between two edges (e.g. period) will be accurate within $\pm 4T_{osc}$ (± 121 ns @ 33 MHz).

FIGURE 12-1: TIMER0 MODULE BLOCK DIAGRAM

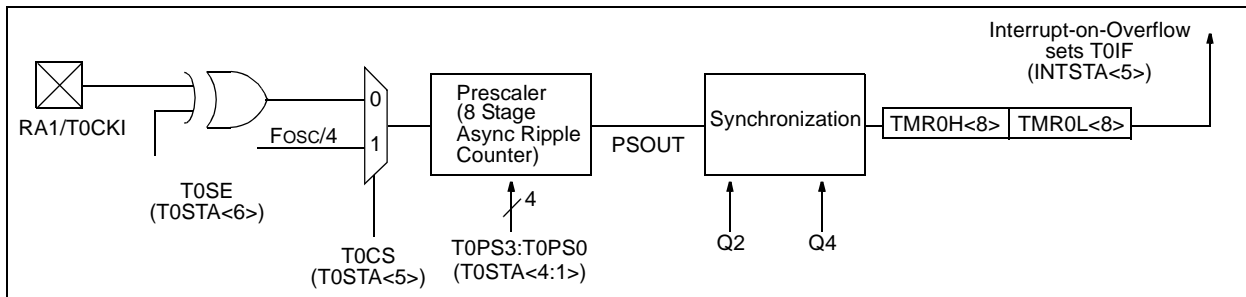
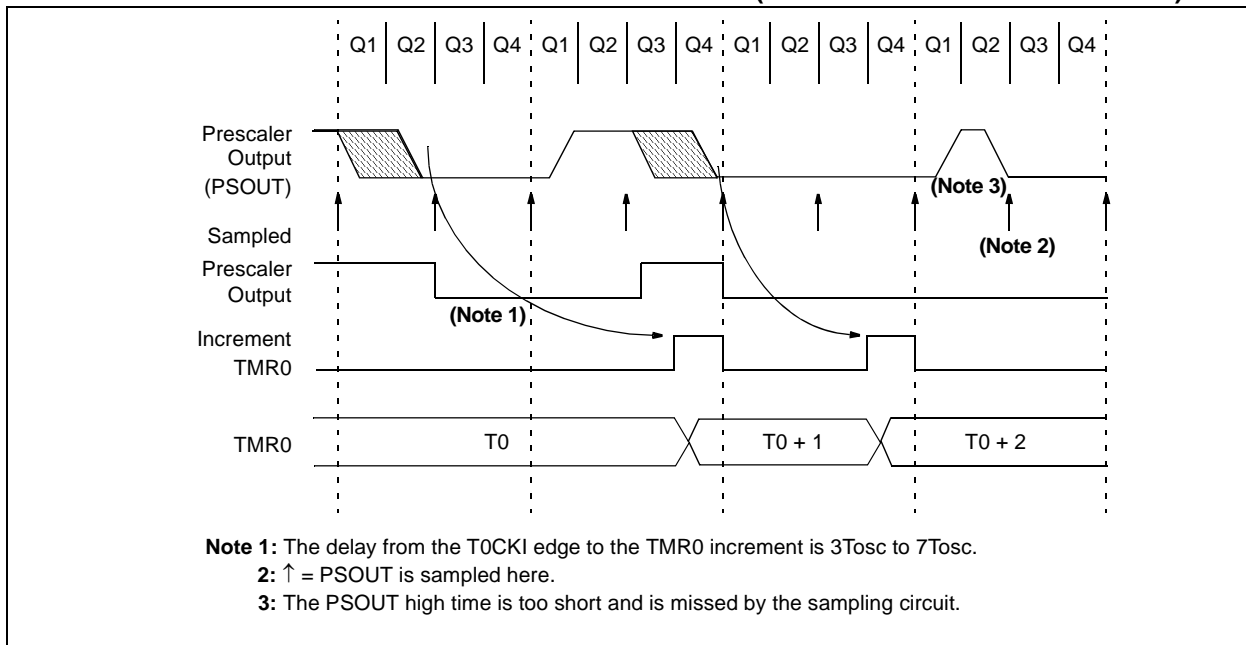

FIGURE 12-2: TMR0 TIMING WITH EXTERNAL CLOCK (INCREMENT ON FALLING EDGE)



12.3 Read/Write Consideration for TMR0

Although TMR0 is a 16-bit timer/counter, only 8-bits at a time can be read or written during a single instruction cycle. Care must be taken during any read or write.

12.3.1 READING 16-BIT VALUE

The problem in reading the entire 16-bit value is that after reading the low (or high) byte, its value may change from FFh to 00h.

Example 12-1 shows a 16-bit read. To ensure a proper read, interrupts must be disabled during this routine.

EXAMPLE 12-1: 16-BIT READ

```
MOVFP  TMR0L, TMPLO  ;read low tmr0
MOVFP  TMR0H, TMPHI  ;read high tmr0
MOVFP  TMPLO, WREG    ;tmplo -> wreg
CPFSLT TMR0L         ;tmr0l < wreg?
RETURN                                ;no then return
MOVFP  TMR0L, TMPLO  ;read low tmr0
MOVFP  TMR0H, TMPHI  ;read high tmr0
RETURN                                ;return
```

12.3.2 WRITING A 16-BIT VALUE TO TMR0

Since writing to either TMR0L or TMR0H will effectively inhibit increment of that half of the TMR0 in the next cycle (following write), but not inhibit increment of the other half, the user must write to TMR0L first and TMR0H second, in two consecutive instructions, as shown in Example 12-2. The interrupt must be disabled. Any write to either TMR0L or TMR0H clears the prescaler.

EXAMPLE 12-2: 16-BIT WRITE

```
BSF    CPUSTA, GLINTD ; Disable interrupts
MOVFP  RAM_L, TMR0L  ;
MOVFP  RAM_H, TMR0H  ;
BCF    CPUSTA, GLINTD ; Done, enable
                          ; interrupts
```

12.4 Prescaler Assignments

Timer0 has an 8-bit prescaler. The prescaler selection is fully under software control; i.e., it can be changed “on the fly” during program execution. Clearing the prescaler is recommended before changing its setting. The value of the prescaler is “unknown” and assigning a value that is less than the present value, makes it difficult to take this unknown time into account.

FIGURE 12-3: TMR0 TIMING: WRITE HIGH OR LOW BYTE

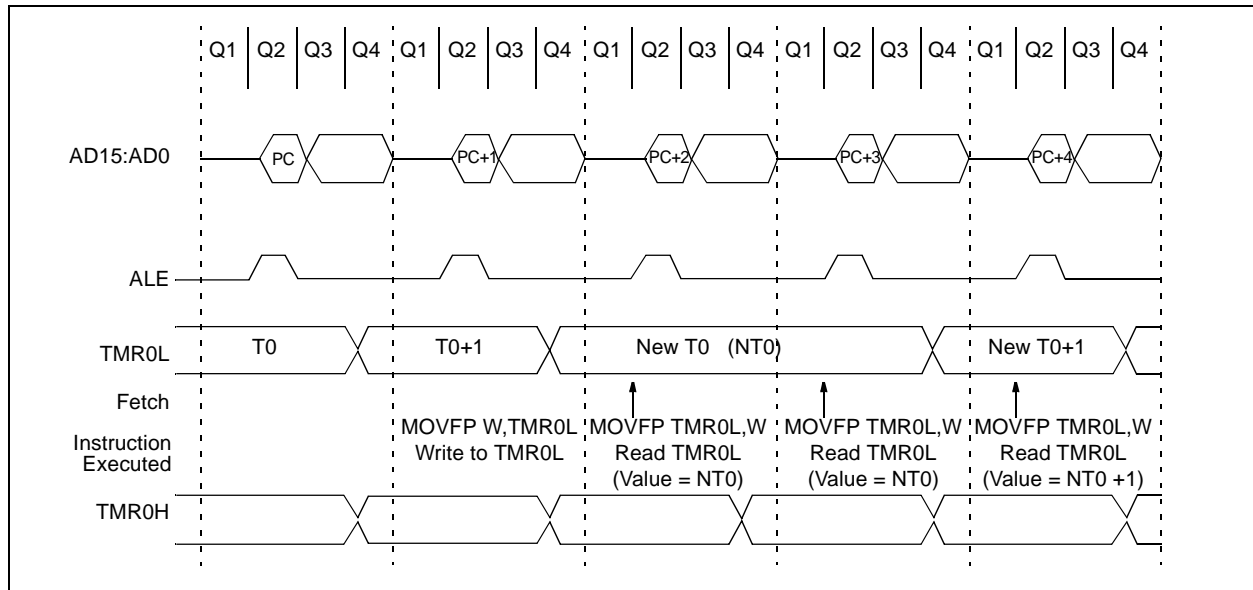

PIC17C7XX

FIGURE 12-4: TMR0 READ/WRITE IN TIMER MODE

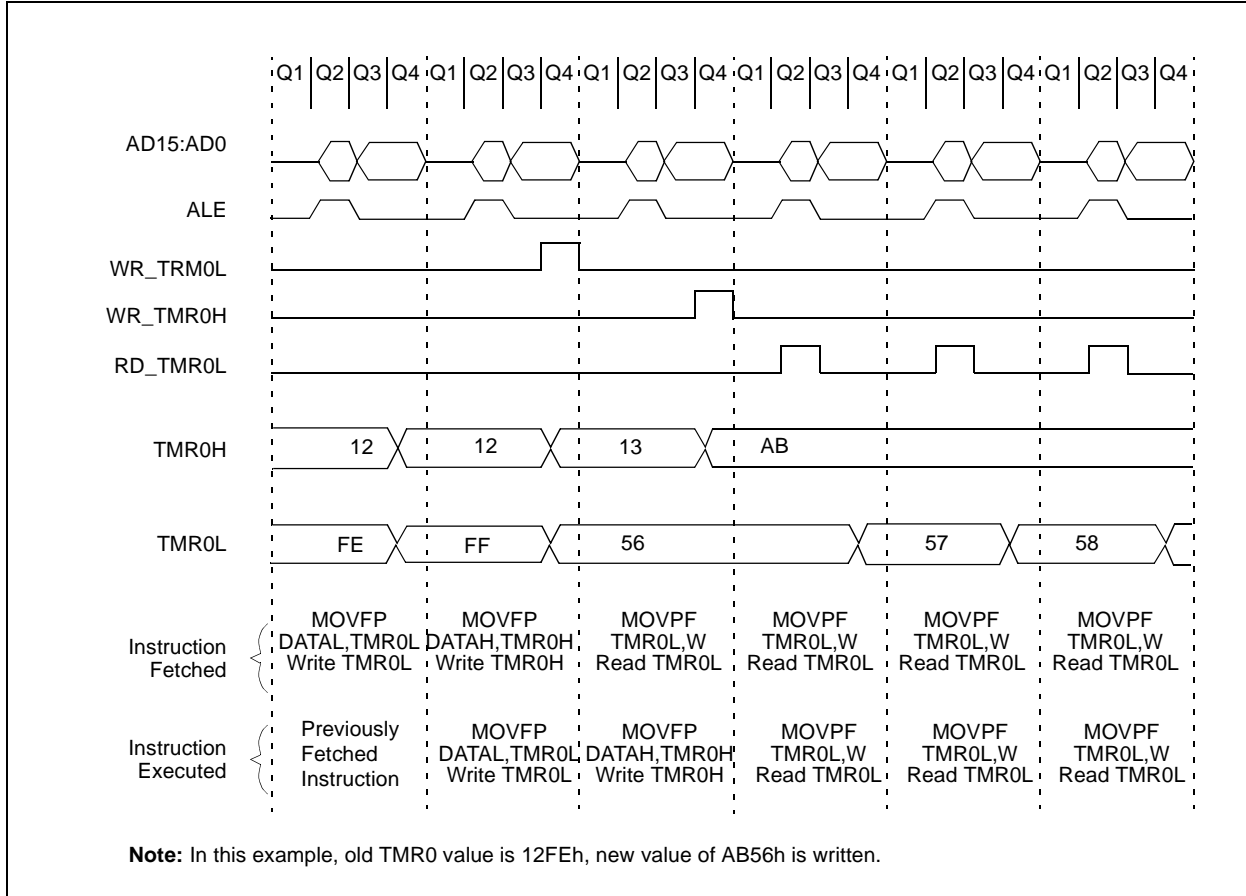

TABLE 12-1: REGISTERS/BITS ASSOCIATED WITH TIMER0

Address	Name	Bit 7	Bit 6	Bit 5	Bit 4	Bit 3	Bit 2	Bit 1	Bit 0	Value on POR, BOR	MCLR, WDT
05h, Unbanked	T0STA	INTEDG	T0SE	T0CS	T0PS3	T0PS2	T0PS1	T0PS0	—	0000 000-	0000 000-
06h, Unbanked	CPUSTA	—	—	STKAV	GLINTD	\overline{TO}	\overline{PD}	\overline{POR}	BOR	--11 11qq	--11 qquu
07h, Unbanked	INTSTA	PEIF	T0CKIF	T0IF	INTF	PEIE	T0CKIE	T0IE	INTE	0000 0000	0000 0000
0Bh, Unbanked	TMR0L	TMR0 Register; Low Byte								xxxx xxxx	uuuu uuuu
0Ch, Unbanked	TMR0H	TMR0 Register; High Byte								xxxx xxxx	uuuu uuuu

Legend: x = unknown, u = unchanged, - = unimplemented, read as a '0', q = value depends on condition. Shaded cells are not used by Timer0.

13.0 TIMER1, TIMER2, TIMER3, PWMS AND CAPTURES

The PIC17C7XX has a wealth of timers and time based functions to ease the implementation of control applications. These time base functions include three PWM outputs and four Capture inputs.

Timer1 and Timer2 are two 8-bit incrementing timers, each with an 8-bit period register (PR1 and PR2, respectively) and separate overflow interrupt flags. Timer1 and Timer2 can operate either as timers (increment on internal $F_{OSC}/4$ clock), or as counters (increment on falling edge of external clock on pin RB4/TCLK12). They are also software configurable to operate as a single 16-bit timer/counter. These timers are also used as the time base for the PWM (Pulse Width Modulation) modules.

Timer3 is a 16-bit timer/counter which uses the TMR3H and TMR3L registers. Timer3 also has two additional registers (PR3H/CA1H:PR3L/CA1L) that are configurable as a 16-bit period register or a 16-bit capture register. TMR3 can be software configured to increment from the internal system clock ($F_{OSC}/4$), or from an external signal on the RB5/TCLK3 pin. Timer3 is the time base for all of the 16-bit captures.

Six other registers comprise the Capture2, Capture3, and Capture4 registers (CA2H:CA2L, CA3H:CA3L, and CA4H:CA4L).

Figure 13-1, Figure 13-2 and Figure 13-3 are the control registers for the operation of Timer1, Timer2 and Timer3, as well as PWM1, PWM2, PWM3, Capture1, Capture2, Capture3 and Capture4.

Table 13-1 shows the Timer resource requirements for these time base functions. Each timer is an open resource so that multiple functions may operate with it.

TABLE 13-1: TIME-BASE FUNCTION/ RESOURCE REQUIREMENTS

Time Base Function	Timer Resource
PWM1	Timer1
PWM2	Timer1 or Timer2
PWM3	Timer1 or Timer2
Capture1	Timer3
Capture2	Timer3
Capture3	Timer3
Capture4	Timer3

REGISTER 13-1: TCON1 REGISTER (ADDRESS: 16h, BANK 3)

R/W-0	R/W-0	R/W-0	R/W-0	R/W-0	R/W-0	R/W-0	R/W-0
CA2ED1	CA2ED0	CA1ED1	CA1ED0	T16	TMR3CS	TMR2CS	TMR1CS
bit 7				bit 0			

- bit 7-6 **CA2ED1:CA2ED0:** Capture2 Mode Select bits
 00 = Capture on every falling edge
 01 = Capture on every rising edge
 10 = Capture on every 4th rising edge
 11 = Capture on every 16th rising edge
- bit 5-4 **CA1ED1:CA1ED0:** Capture1 Mode Select bits
 00 = Capture on every falling edge
 01 = Capture on every rising edge
 10 = Capture on every 4th rising edge
 11 = Capture on every 16th rising edge
- bit 3 **T16:** Timer2:Timer1 Mode Select bit
 1 = Timer2 and Timer1 form a 16-bit timer
 0 = Timer2 and Timer1 are two 8-bit timers
- bit 2 **TMR3CS:** Timer3 Clock Source Select bit
 1 = TMR3 increments off the falling edge of the RB5/TCLK3 pin
 0 = TMR3 increments off the internal clock
- bit 1 **TMR2CS:** Timer2 Clock Source Select bit
 1 = TMR2 increments off the falling edge of the RB4/TCLK12 pin
 0 = TMR2 increments off the internal clock
- bit 0 **TMR1CS:** Timer1 Clock Source Select bit
 1 = TMR1 increments off the falling edge of the RB4/TCLK12 pin
 0 = TMR1 increments off the internal clock

Legend:			
R = Readable bit	W = Writable bit	U = Unimplemented bit, read as '0'	
- n = Value at POR Reset	'1' = Bit is set	'0' = Bit is cleared	x = Bit is unknown

PIC17C7XX

REGISTER 13-2: TCON2 REGISTER (ADDRESS: 17h, BANK 3)

R-0	R-0	R/W-0	R/W-0	R/W-0	R/W-0	R/W-0	R/W-0
CA2OVF	CA1OVF	PWM2ON	PWM1ON	CA1/PR3	TMR3ON	TMR2ON	TMR1ON

bit 7

bit 0

- bit 7 **CA2OVF:** Capture2 Overflow Status bit
 This bit indicates that the capture value had not been read from the capture register pair (CA2H:CA2L) before the next capture event occurred. The capture register retains the oldest unread capture value (last capture before overflow). Subsequent capture events will not update the capture register with the TMR3 value until the capture register has been read (both bytes).
 1 = Overflow occurred on Capture2 register
 0 = No overflow occurred on Capture2 register
- bit 6 **CA1OVF:** Capture1 Overflow Status bit
 This bit indicates that the capture value had not been read from the capture register pair (PR3H/CA1H:PR3L/CA1L), before the next capture event occurred. The capture register retains the oldest unread capture value (last capture before overflow). Subsequent capture events will not update the capture register with the TMR3 value until the capture register has been read (both bytes).
 1 = Overflow occurred on Capture1 register
 0 = No overflow occurred on Capture1 register
- bit 5 **PWM2ON:** PWM2 On bit
 1 = PWM2 is enabled
 (The RB3/PWM2 pin ignores the state of the DDRB<3> bit.)
 0 = PWM2 is disabled
 (The RB3/PWM2 pin uses the state of the DDRB<3> bit for data direction.)
- bit 4 **PWM1ON:** PWM1 On bit
 1 = PWM1 is enabled
 (The RB2/PWM1 pin ignores the state of the DDRB<2> bit.)
 0 = PWM1 is disabled
 (The RB2/PWM1 pin uses the state of the DDRB<2> bit for data direction.)
- bit 3 **CA1/PR3:** CA1/PR3 Register Mode Select bit
 1 = Enables Capture1
 (PR3H/CA1H:PR3L/CA1L is the Capture1 register. Timer3 runs without a period register.)
 0 = Enables the Period register
 (PR3H/CA1H:PR3L/CA1L is the Period register for Timer3.)
- bit 2 **TMR3ON:** Timer3 On bit
 1 = Starts Timer3
 0 = Stops Timer3
- bit 1 **TMR2ON:** Timer2 On bit
 This bit controls the incrementing of the TMR2 register. When TMR2:TMR1 form the 16-bit timer (T16 is set), TMR2ON must be set. This allows the MSB of the timer to increment.
 1 = Starts Timer2 (must be enabled if the T16 bit (TCON1<3>) is set)
 0 = Stops Timer2
- bit 0 **TMR1ON:** Timer1 On bit
When T16 is set (in 16-bit Timer mode):
 1 = Starts 16-bit TMR2:TMR1
 0 = Stops 16-bit TMR2:TMR1
When T16 is clear (in 8-bit Timer mode):
 1 = Starts 8-bit Timer1
 0 = Stops 8-bit Timer1

Legend:			
R = Readable bit	W = Writable bit	U = Unimplemented bit, read as '0'	
- n = Value at POR Reset	'1' = Bit is set	'0' = Bit is cleared	x = Bit is unknown

REGISTER 13-3: TCON3 REGISTER (ADDRESS: 16h, BANK 7)

U-0	R-0	R-0	R/W-0	R/W-0	R/W-0	R/W-0	R/W-0
—	CA4OVF	CA3OVF	CA4ED1	CA4ED0	CA3ED1	CA3ED0	PWM3ON
bit 7							bit 0

- bit 7 **Unimplemented:** Read as '0'
- bit 6 **CA4OVF:** Capture4 Overflow Status bit
 This bit indicates that the capture value had not been read from the capture register pair (CA4H:CA4L) before the next capture event occurred. The capture register retains the oldest unread capture value (last capture before overflow). Subsequent capture events will not update the capture register with the TMR3 value until the capture register has been read (both bytes).
 1 = Overflow occurred on Capture4 registers
 0 = No overflow occurred on Capture4 registers
- bit 5 **CA3OVF:** Capture3 Overflow Status bit
 This bit indicates that the capture value had not been read from the capture register pair (CA3H:CA3L) before the next capture event occurred. The capture register retains the oldest unread capture value (last capture before overflow). Subsequent capture events will not update the capture register with the TMR3 value until the capture register has been read (both bytes).
 1 = Overflow occurred on Capture3 registers
 0 = No overflow occurred on Capture3 registers
- bit 4-3 **CA4ED1:CA4ED0:** Capture4 Mode Select bits
 00 = Capture on every falling edge
 01 = Capture on every rising edge
 10 = Capture on every 4th rising edge
 11 = Capture on every 16th rising edge
- bit 2-1 **CA3ED1:CA3ED0:** Capture3 Mode Select bits
 00 = Capture on every falling edge
 01 = Capture on every rising edge
 10 = Capture on every 4th rising edge
 11 = Capture on every 16th rising edge
- bit 0 **PWM3ON:** PWM3 On bit
 1 = PWM3 is enabled (the RG5/PWM3 pin ignores the state of the DDRG<5> bit)
 0 = PWM3 is disabled (the RG5/PWM3 pin uses the state of the DDRG<5> bit for data direction)

Legend:			
R = Readable bit	W = Writable bit	U = Unimplemented bit, read as '0'	
- n = Value at POR Reset	'1' = Bit is set	'0' = Bit is cleared	x = Bit is unknown

PIC17C7XX

13.1 Timer1 and Timer2

13.1.1 TIMER1, TIMER2 IN 8-BIT MODE

Both Timer1 and Timer2 will operate in 8-bit mode when the T16 bit is clear. These two timers can be independently configured to increment from the internal instruction cycle clock (T_{CY}), or from an external clock source on the RB4/TCLK12 pin. The timer clock source is configured by the TMRxCS bit ($x = 1$ for Timer1, or $= 2$ for Timer2). When TMRxCS is clear, the clock source is internal and increments once every instruction cycle ($F_{OSC}/4$). When TMRxCS is set, the clock source is the RB4/TCLK12 pin and the counters will increment on every falling edge of the RB4/TCLK12 pin.

The timer increments from 00h until it equals the Period register (PRx). It then resets to 00h at the next increment cycle. The timer interrupt flag is set when the timer is reset. TMR1 and TMR2 have individual interrupt flag bits. The TMR1 interrupt flag bit is latched into TMR1IF and the TMR2 interrupt flag bit is latched into TMR2IF.

Each timer also has a corresponding interrupt enable bit (TMRxIE). The timer interrupt can be enabled/disabled by setting/clearing this bit. For peripheral interrupts to be enabled, the Peripheral Interrupt Enable bit must be set ($PEIE = '1'$) and global interrupt must be enabled ($GLINTD = '0'$).

The timers can be turned on and off under software control. When the timer on control bit (TMRxON) is set, the timer increments from the clock source. When TMRxON is cleared, the timer is turned off and cannot cause the timer interrupt flag to be set.

13.1.1.1 External Clock Input for Timer1 and Timer2

When TMRxCS is set, the clock source is the RB4/TCLK12 pin, and the counter will increment on every falling edge on the RB4/TCLK12 pin. The TCLK12 input is synchronized with internal phase clocks. This causes a delay from the time a falling edge appears on TCLK12 to the time TMR1 or TMR2 is actually incremented. For the external clock input timing requirements, see the Electrical Specification section.

FIGURE 13-1: TIMER1 AND TIMER2 IN TWO 8-BIT TIMER/COUNTER MODE

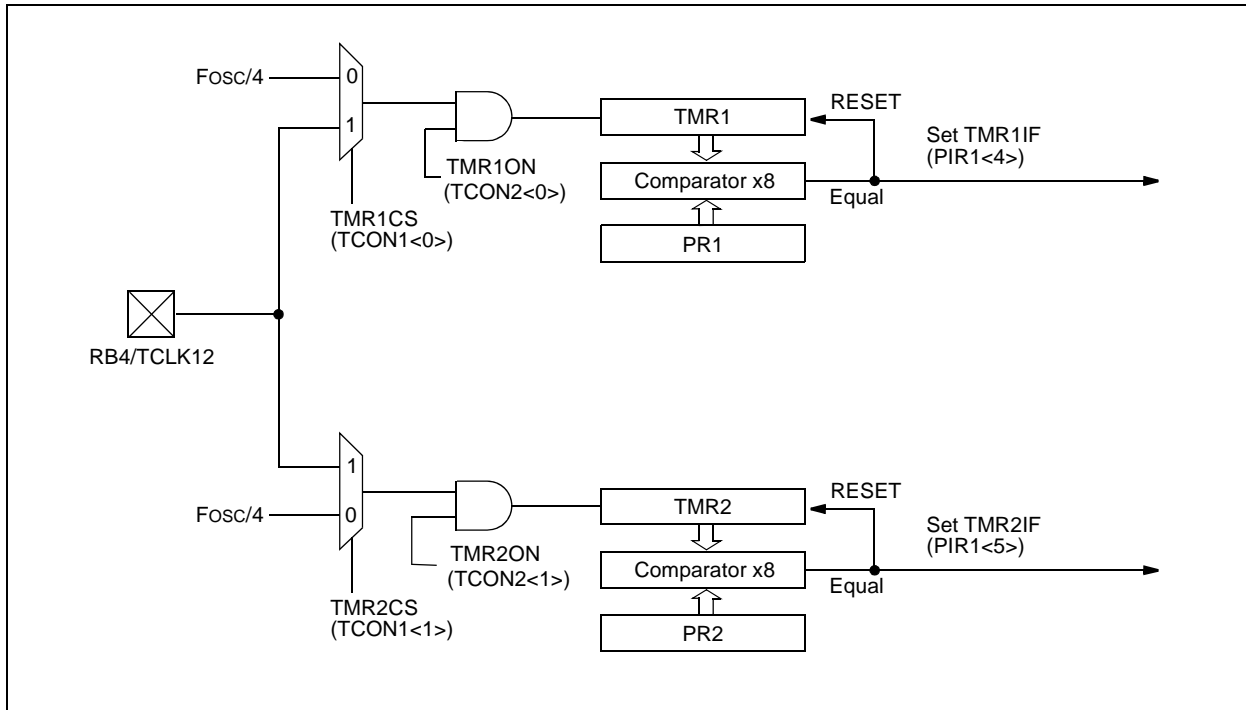

13.1.2 TIMER1 AND TIMER2 IN 16-BIT MODE

To select 16-bit mode, set the T16 bit. In this mode, TMR2 and TMR1 are concatenated to form a 16-bit timer (TMR2:TMR1). The 16-bit timer increments until it matches the 16-bit period register (PR2:PR1). On the following timer clock, the timer value is reset to 0h, and the TMR1IF bit is set.

When selecting the clock source for the 16-bit timer, the TMR1CS bit controls the entire 16-bit timer and TMR2CS is a “don’t care”, however, ensure that TMR2ON is set (allows TMR2 to increment). When TMR1CS is set, the timer increments once every instruction cycle ($F_{osc}/4$). When TMR1CS is clear, the timer increments on every falling edge of the RB4/TCLK12 pin. For the 16-bit timer to increment, both TMR1ON and TMR2ON bits must be set (Table 13-2).

13.1.2.1 External Clock Input for TMR2:TMR1

When TMR1CS is set, the 16-bit TMR2:TMR1 increments on the falling edge of clock input TCLK12. The input on the RB4/TCLK12 pin is sampled and synchronized by the internal phase clocks twice every instruction cycle. This causes a delay from the time a falling edge appears on RB4/TCLK12 to the time TMR2:TMR1 is actually incremented. For the external clock input timing requirements, see the Electrical Specification section.

TABLE 13-2: TURNING ON 16-BIT TIMER

T16	TMR2ON	TMR1ON	Result
1	1	1	16-bit timer (TMR2:TMR1) ON
1	0	1	Only TMR1 increments
1	x	0	16-bit timer OFF
0	1	1	Timers in 8-bit mode

FIGURE 13-2: TMR2 AND TMR1 IN 16-BIT TIMER/COUNTER MODE

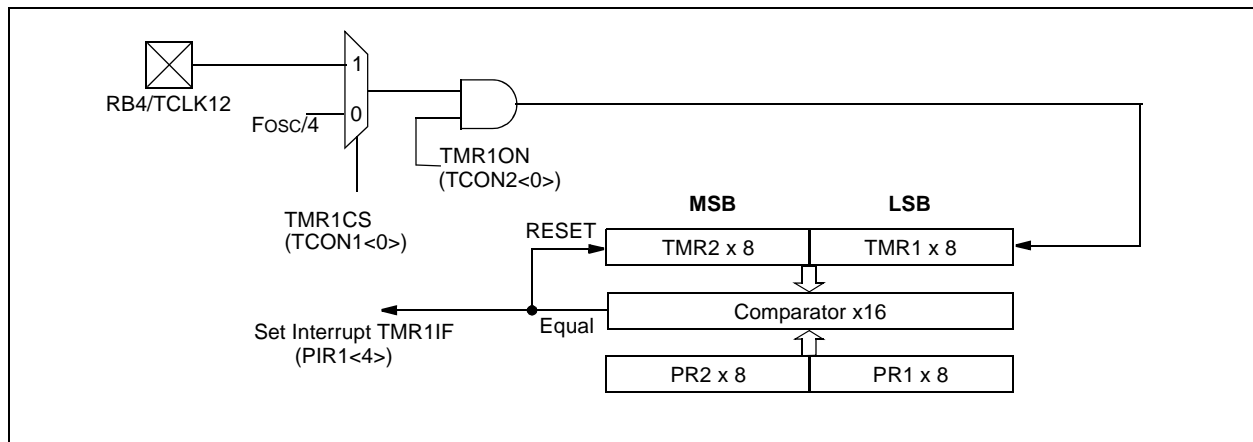

PIC17C7XX

TABLE 13-3: SUMMARY OF TIMER1, TIMER2 AND TIMER3 REGISTERS

Address	Name	Bit 7	Bit 6	Bit 5	Bit 4	Bit 3	Bit 2	Bit 1	Bit 0	Value on POR, BOR	MCLR, WDT
16h, Bank 3	TCON1	CA2ED1	CA2ED0	CA1ED1	CA1ED0	T16	TMR3CS	TMR2CS	TMR1CS	0000 0000	0000 0000
17h, Bank 3	TCON2	CA2OVF	CA1OVF	PWM2ON	PWM1ON	CA1/PR3	TMR3ON	TMR2ON	TMR1ON	0000 0000	0000 0000
16h, Bank 7	TCON3	—	CA4OVF	CA3OVF	CA4ED1	CA4ED0	CA3ED1	CA3ED0	PWM3ON	-000 0000	-000 0000
10h, Bank 2	TMR1	Timer1's Register								xxxx xxxx	uuuu uuuu
11h, Bank 2	TMR2	Timer2's Register								xxxx xxxx	uuuu uuuu
16h, Bank 1	PIR1	RBIF	TMR3IF	TMR2IF	TMR1IF	CA2IF	CA1IF	TX1IF	RC1IF	x000 0010	u000 0010
17h, Bank 1	PIE1	RBIE	TMR3IE	TMR2IE	TMR1IE	CA2IE	CA1IE	TX1IE	RC1IE	0000 0000	0000 0000
07h, Unbanked	INTSTA	PEIF	T0CKIF	T0IF	INTF	PEIE	T0CKIE	T0IE	INTE	0000 0000	0000 0000
06h, Unbanked	CPUSTA	—	—	STKAV	GLINTD	T0	PD	POR	BOR	--11 11qq	--11 qquu
14h, Bank 2	PR1	Timer1 Period Register								xxxx xxxx	uuuu uuuu
15h, Bank 2	PR2	Timer2 Period Register								xxxx xxxx	uuuu uuuu
10h, Bank 3	PW1DCL	DC1	DC0	—	—	—	—	—	—	xx-- ----	uu-- ----
11h, Bank 3	PW2DCL	DC1	DC0	TM2PW2	—	—	—	—	—	xx0- ----	uu0- ----
10h, Bank 7	PW3DCL	DC1	DC0	TM2PW3	—	—	—	—	—	xx0- ----	uu0- ----
12h, Bank 3	PW1DCH	DC9	DC8	DC7	DC6	DC5	DC4	DC3	DC2	xxxx xxxx	uuuu uuuu
13h, Bank 3	PW2DCH	DC9	DC8	DC7	DC6	DC5	DC4	DC3	DC2	xxxx xxxx	uuuu uuuu
11h, Bank 7	PW3DCH	DC9	DC8	DC7	DC6	DC5	DC4	DC3	DC2	xxxx xxxx	uuuu uuuu

Legend: x = unknown, u = unchanged, - = unimplemented, read as a '0', q = value depends on condition.
 Shaded cells are not used by Timer1 or Timer2.

13.1.3 USING PULSE WIDTH MODULATION (PWM) OUTPUTS WITH TIMER1 AND TIMER2

Three high speed pulse width modulation (PWM) outputs are provided. The PWM1 output uses Timer1 as its time base, while PWM2 and PWM3 may independently be software configured to use either Timer1 or Timer2 as the time base. The PWM outputs are on the RB2/PWM1, RB3/PWM2 and RG5/PWM3 pins.

Each PWM output has a maximum resolution of 10-bits. At 10-bit resolution, the PWM output frequency is 32.2 kHz (@ 32 MHz clock) and at 8-bit resolution the PWM output frequency is 128.9 kHz. The duty cycle of the output can vary from 0% to 100%.

Figure 13-3 shows a simplified block diagram of a PWM module.

The duty cycle registers are double buffered for glitch free operation. Figure 13-4 shows how a glitch could occur if the duty cycle registers were not double buffered.

The user needs to set the PWM1ON bit (TCON2<4>) to enable the PWM1 output. When the PWM1ON bit is set, the RB2/PWM1 pin is configured as PWM1 output and forced as an output, irrespective of the data direction bit (DDRB<2>). When the PWM1ON bit is clear, the pin behaves as a port pin and its direction is controlled by its data direction bit (DDRB<2>). Similarly, the PWM2ON (TCON2<5>) bit controls the configuration of the RB3/PWM2 pin and the PWM3ON (TCON3<0>) bit controls the configuration of the RG5/PWM3 pin.

FIGURE 13-3: SIMPLIFIED PWM BLOCK DIAGRAM

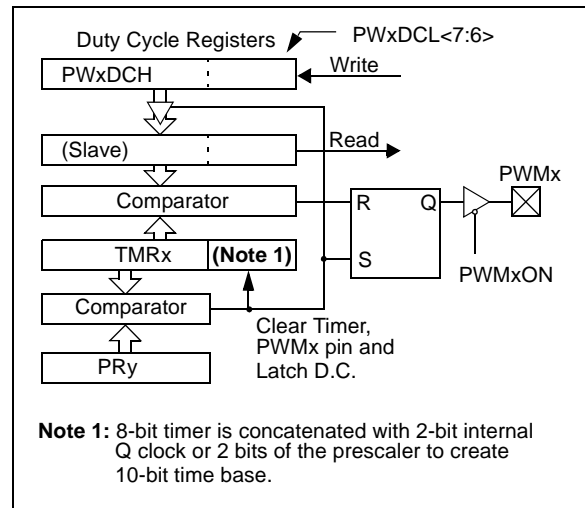
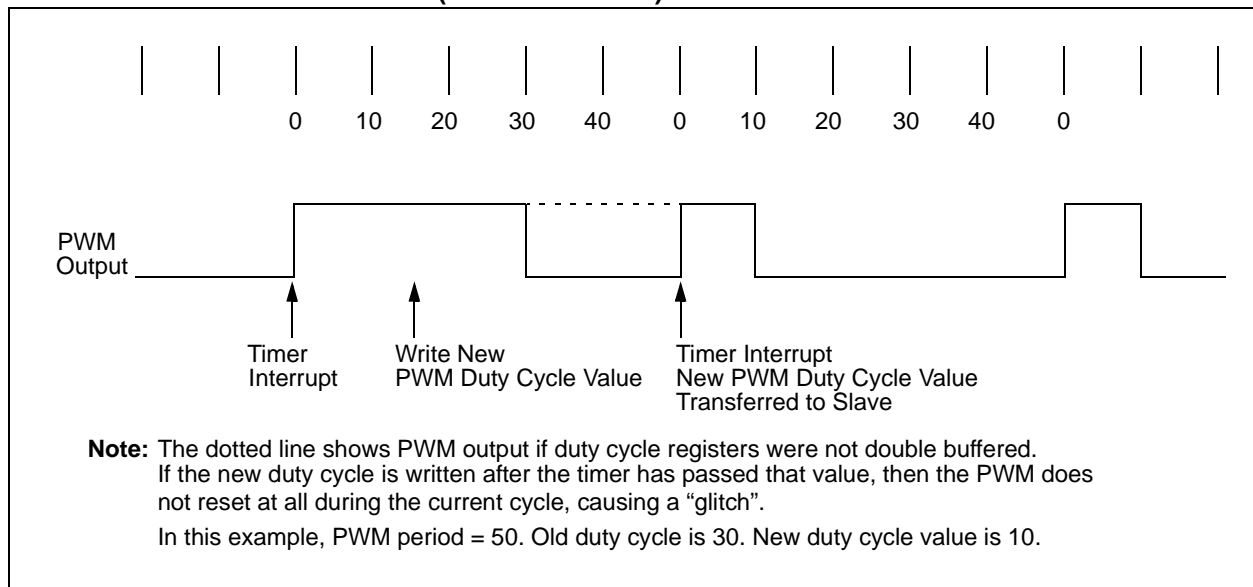

FIGURE 13-4: PWM OUTPUT (NOT BUFFERED)



PIC17C7XX

13.1.3.1 PWM Periods

The period of the PWM1 output is determined by Timer1 and its period register (PR1). The period of the PWM2 and PWM3 outputs can be individually software configured to use either Timer1 or Timer2 as the time-base. For PWM2, when TM2PW2 bit (PW2DCL<5>) is clear, the time base is determined by TMR1 and PR1 and when TM2PW2 is set, the time base is determined by Timer2 and PR2. For PWM3, when TM2PW3 bit (PW3DCL<5>) is clear, the time base is determined by TMR1 and PR1, and when TM2PW3 is set, the time base is determined by Timer2 and PR2.

Running two different PWM outputs on two different timers allows different PWM periods. Running all PWMs from Timer1 allows the best use of resources by freeing Timer2 to operate as an 8-bit timer. Timer1 and Timer2 cannot be used as a 16-bit timer if any PWM is being used.

The PWM periods can be calculated as follows:

$$\text{period of PWM1} = [(PR1) + 1] \times 4T_{OSC}$$

$$\text{period of PWM2} = [(PR1) + 1] \times 4T_{OSC} \quad \text{or} \\ [(PR2) + 1] \times 4T_{OSC}$$

$$\text{period of PWM3} = [(PR1) + 1] \times 4T_{OSC} \quad \text{or} \\ [(PR2) + 1] \times 4T_{OSC}$$

The duty cycle of PWMx is determined by the 10-bit value DCx<9:0>. The upper 8-bits are from register PWxDCH and the lower 2-bits are from PWxDCL<7:6> (PWxDCH:PWxDCL<7:6>). Table 13-4 shows the maximum PWM frequency (FPWM), given the value in the period register.

The number of bits of resolution that the PWM can achieve depends on the operation frequency of the device as well as the PWM frequency (FPWM).

Maximum PWM resolution (bits) for a given PWM frequency:

$$= \frac{\log\left(\frac{F_{OSC}}{F_{PWM}}\right)}{\log(2)} \quad \text{bits}$$

where: $F_{PWM} = 1 / \text{period of PWM}$

The PWMx duty cycle is as follows:

$$\text{PWMx Duty Cycle} = (DCx) \times T_{OSC}$$

where DCx represents the 10-bit value from PWxDCH:PWxDCL.

If $DCx = 0$, then the duty cycle is zero. If $PRx = PWxDCH$, then the PWM output will be low for one to four Q-clocks (depending on the state of the PWxDCL<7:6> bits). For a duty cycle to be 100%, the PWxDCH value must be greater than the PRx value.

The duty cycle registers for both PWM outputs are double buffered. When the user writes to these registers, they are stored in master latches. When TMR1 (or TMR2) overflows and a new PWM period begins, the master latch values are transferred to the slave latches and the PWMx pin is forced high.

Note: For PW1DCH, PW1DCL, PW2DCH, PW2DCL, PW3DCH and PW3DCL registers, a write operation writes to the "master latches", while a read operation reads the "slave latches". As a result, the user may not read back what was just written to the duty cycle registers (until transferred to slave latch).

The user should also avoid any "read-modify-write" operations on the duty cycle registers, such as: `ADDWF PW1DCH`. This may cause duty cycle outputs that are unpredictable.

TABLE 13-4: PWM FREQUENCY vs. RESOLUTION AT 33 MHz

PWM Frequency	Frequency (kHz)				
	32.2	64.5	90.66	128.9	515.6
PRx Value	0xFF	0x7F	0x5A	0x3F	0x0F
High Resolution	10-bit	9-bit	8.5-bit	8-bit	6-bit
Standard Resolution	8-bit	7-bit	6.5-bit	6-bit	4-bit

13.1.3.2 PWM INTERRUPTS

The PWM modules make use of the TMR1 and/or TMR2 interrupts. A timer interrupt is generated when TMR1 or TMR2 equals its period register and on the following increment is cleared to zero. This interrupt also marks the beginning of a PWM cycle. The user can write new duty cycle values before the timer rollover. The TMR1 interrupt is latched into the TMR1IF bit and the TMR2 interrupt is latched into the TMR2IF bit. These flags must be cleared in software.

13.1.3.3 External Clock Source

The PWMs will operate, regardless of the clock source of the timer. The use of an external clock has ramifications that must be understood. Because the external TCLK12 input is synchronized internally (sampled once per instruction cycle), the time TCLK12 changes to the time the timer increments, will vary by as much as 1Tcy (one instruction cycle). This will cause jitter in the duty cycle as well as the period of the PWM output.

This jitter will be $\pm 1Tcy$, unless the external clock is synchronized with the processor clock. Use of one of the PWM outputs as the clock source to the TCLK12 input, will supply a synchronized clock.

In general, when using an external clock source for PWM, its frequency should be much less than the device frequency (Fosc).

13.1.3.4 Maximum Resolution/Frequency for External Clock Input

The use of an external clock for the PWM time base (Timer1 or Timer2) limits the PWM output to a maximum resolution of 8-bits. The PWxDCL<7:6> bits must be kept cleared. Use of any other value will distort the PWM output. All resolutions are supported when internal clock mode is selected. The maximum attainable frequency is also lower. This is a result of the timing requirements of an external clock input for a timer (see the Electrical Specification section). The maximum PWM frequency, when the timers clock source is the RB4/TCLK12 pin, is shown in Table 13-4 (Standard Resolution mode).

TABLE 13-5: REGISTERS/BITS ASSOCIATED WITH PWM

Address	Name	Bit 7	Bit 6	Bit 5	Bit 4	Bit 3	Bit 2	Bit 1	Bit 0	Value on POR, BOR	MCLR, WDT
16h, Bank 3	TCON1	CA2ED1	CA2ED0	CA1ED1	CA1ED0	T16	TMR3CS	TMR2CS	TMR1CS	0000 0000	0000 0000
17h, Bank 3	TCON2	CA2OVF	CA1OVF	PWM2ON	PWM1ON	CA1/PR3	TMR3ON	TMR2ON	TMR1ON	0000 0000	0000 0000
16h, Bank 7	TCON3	—	CA4OVF	CA3OVF	CA4ED1	CA4ED0	CA3ED1	CA3ED0	PWM3ON	-000 0000	-000 0000
10h, Bank 2	TMR1	Timer1's Register								xxxx xxxx	uuuu uuuu
11h, Bank 2	TMR2	Timer2's Register								xxxx xxxx	uuuu uuuu
16h, Bank 1	PIR1	RBIF	TMR3IF	TMR2IF	TMR1IF	CA2IF	CA1IF	TX1IF	RC1IF	x000 0010	u000 0010
17h, Bank 1	PIE1	RBIE	TMR3IE	TMR2IE	TMR1IE	CA2IE	CA1IE	TX1IE	RC1IE	0000 0000	0000 0000
07h, Unbanked	INTSTA	PEIF	T0CKIF	T0IF	INTF	PEIE	T0CKIE	T0IE	INTE	0000 0000	0000 0000
06h, Unbanked	CPUSTA	—	—	STKAV	GLINTD	\overline{TO}	\overline{PD}	POR	BOR	--11 11qq	--11 qquu
14h, Bank 2	PR1	Timer1 Period Register								xxxx xxxx	uuuu uuuu
15h, Bank 2	PR2	Timer2 Period Register								xxxx xxxx	uuuu uuuu
10h, Bank 3	PW1DCL	DC1	DC0	—	—	—	—	—	—	xx-- ----	uu-- ----
11h, Bank 3	PW2DCL	DC1	DC0	TM2PW2	—	—	—	—	—	xx0- ----	uu0- ----
10h, Bank 7	PW3DCL	DC1	DC0	TM2PW3	—	—	—	—	—	xx0- ----	uu0- ----
12h, Bank 3	PW1DCH	DC9	DC8	DC7	DC6	DC5	DC4	DC3	DC2	xxxx xxxx	uuuu uuuu
13h, Bank 3	PW2DCH	DC9	DC8	DC7	DC6	DC5	DC4	DC3	DC2	xxxx xxxx	uuuu uuuu
11h, Bank 7	PW3DCH	DC9	DC8	DC7	DC6	DC5	DC4	DC3	DC2	xxxx xxxx	uuuu uuuu

Legend: x = unknown, u = unchanged, - = unimplemented, read as '0', q = value depends on conditions. Shaded cells are not used by PWM Module.

PIC17C7XX

13.2 Timer3

Timer3 is a 16-bit timer consisting of the TMR3H and TMR3L registers. TMR3H is the high byte of the timer and TMR3L is the low byte. This timer has an associated 16-bit period register (PR3H/CA1H:PR3L/CA1L). This period register can be software configured to be another 16-bit capture register.

When the TMR3CS bit (TCON1<2>) is clear, the timer increments every instruction cycle ($F_{osc}/4$). When TMR3CS is set, the counter increments on every falling edge of the RB5/TCLK3 pin. In either mode, the TMR3ON bit must be set for the timer/counter to increment. When TMR3ON is clear, the timer will not increment or set flag bit TMR3IF.

Timer3 has two modes of operation, depending on the CA1/PR3 bit (TCON2<3>). These modes are:

- Three capture and one period register mode
- Four capture register mode

The PIC17C7XX has up to four 16-bit capture registers that capture the 16-bit value of TMR3 when events are detected on capture pins. There are four capture pins

(RB0/CAP1, RB1/CAP2, RG4/CAP3, and RE3/CAP4), one for each capture register pair. The capture pins are multiplexed with the I/O pins. An event can be:

- A rising edge
- A falling edge
- Every 4th rising edge
- Every 16th rising edge

Each 16-bit capture register has an interrupt flag associated with it. The flag is set when a capture is made. The capture modules are truly part of the Timer3 block. Figure 13-5 and Figure 13-6 show the block diagrams for the two modes of operation.

13.2.1 THREE CAPTURE AND ONE PERIOD REGISTER MODE

In this mode, registers PR3H/CA1H and PR3L/CA1L constitute a 16-bit period register. A block diagram is shown in Figure 13-5. The timer increments until it equals the period register and then resets to 0000h on the next timer clock. TMR3 Interrupt Flag bit (TMR3IF) is set at this point. This interrupt can be disabled by clearing the TMR3 Interrupt Enable bit (TMR3IE). TMR3IF must be cleared in software.

FIGURE 13-5: TIMER3 WITH THREE CAPTURE AND ONE PERIOD REGISTER BLOCK DIAGRAM

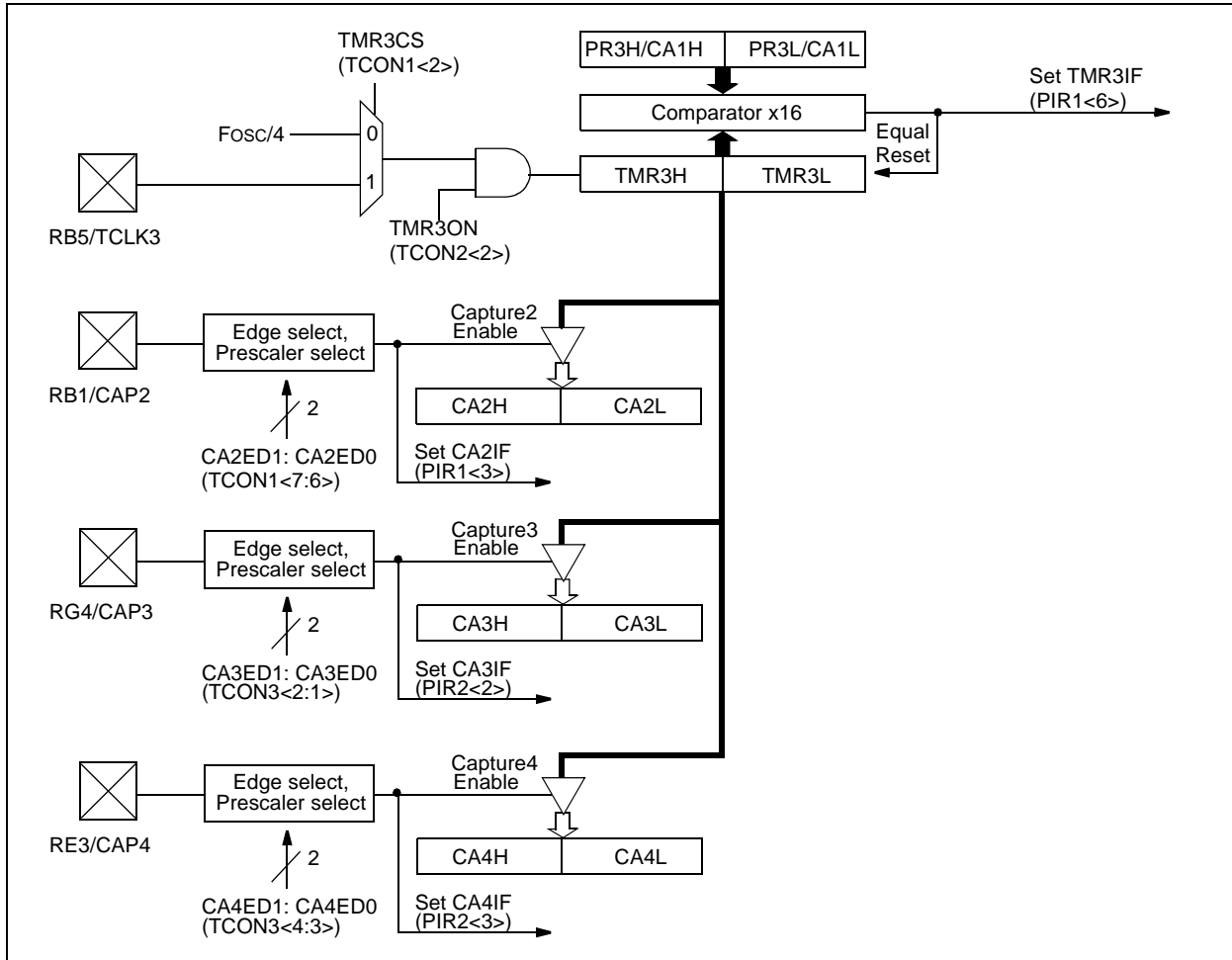

This mode (3 Capture, 1 Period) is selected if control bit CA1/PR3 is clear. In this mode, the Capture1 register, consisting of high byte (PR3H/CA1H) and low byte (PR3L/CA1L), is configured as the period control register for TMR3. Capture1 is disabled in this mode and the corresponding interrupt bit, CA1IF, is never set. TMR3 increments until it equals the value in the period register and then resets to 0000h on the next timer clock.

All other Captures are active in this mode.

13.2.1.1 Capture Operation

The CAXED1 and CAXED0 bits determine the event on which capture will occur. The possible events are:

- Capture on every falling edge
- Capture on every rising edge
- Capture every 4th rising edge
- Capture every 16th rising edge

When a capture takes place, an interrupt flag is latched into the CAXIF bit. This interrupt can be enabled by setting the corresponding mask bit CAXIE. The Peripheral Interrupt Enable bit (PEIE) must be set and the Global Interrupt Disable bit (GLINTD) must be cleared for the interrupt to be acknowledged. The CAXIF interrupt flag bit is cleared in software.

When the capture prescale select is changed, the prescaler is not reset and an event may be generated. Therefore, the first capture after such a change will be ambiguous. However, it sets the time-base for the next capture. The prescaler is reset upon chip RESET.

The capture pin, CAPx, is a multiplexed pin. When used as a port pin, the capture is not disabled. However, the user can simply disable the Capture interrupt by clearing CAXIE. If the CAPx pin is used as an output pin, the user can activate a capture by writing to the port pin. This may be useful during development phase to emulate a capture interrupt.

The input on the capture pin CAPx is synchronized internally to internal phase clocks. This imposes certain restrictions on the input waveform (see the Electrical Specification section for timing).

The capture overflow status flag bit is double buffered. The master bit is set if one captured word is already residing in the Capture register (CAXH:CAXL) and another “event” has occurred on the CAPx pin. The new event will not transfer the TMR3 value to the capture register, protecting the previous unread capture value. When the user reads both the high and the low bytes (in any order) of the Capture register, the master overflow bit is transferred to the slave overflow bit (CAXOVF) and then the master bit is reset. The user can then read TCONx to determine the value of CAXOVF.

The recommended sequence to read capture registers and capture overflow flag bits is shown in Example 13-1.

PIC17C7XX

13.2.2 FOUR CAPTURE MODE

This mode is selected by setting bit CA1/PR3. A block diagram is shown in Figure 13-6. In this mode, TMR3 runs without a period register and increments from 0000h to FFFFh and rolls over to 0000h. The TMR3 interrupt Flag (TMR3IF) is set on this rollover. The TMR3IF bit must be cleared in software.

Registers PR3H/CA1H and PR3L/CA1L make a 16-bit capture register (Capture1). It captures events on pin RB0/CAP1. Capture mode is configured by the CA1ED1 and CA1ED0 bits. Capture1 Interrupt Flag bit (CA1IF) is set upon detection of the capture event. The corresponding interrupt mask bit is CA1IE. The Capture1 Overflow Status bit is CA1OVF.

All the captures operate in the same manner. Refer to Section 13.2.1 for the operation of capture.

FIGURE 13-6: TIMER3 WITH FOUR CAPTURES BLOCK DIAGRAM

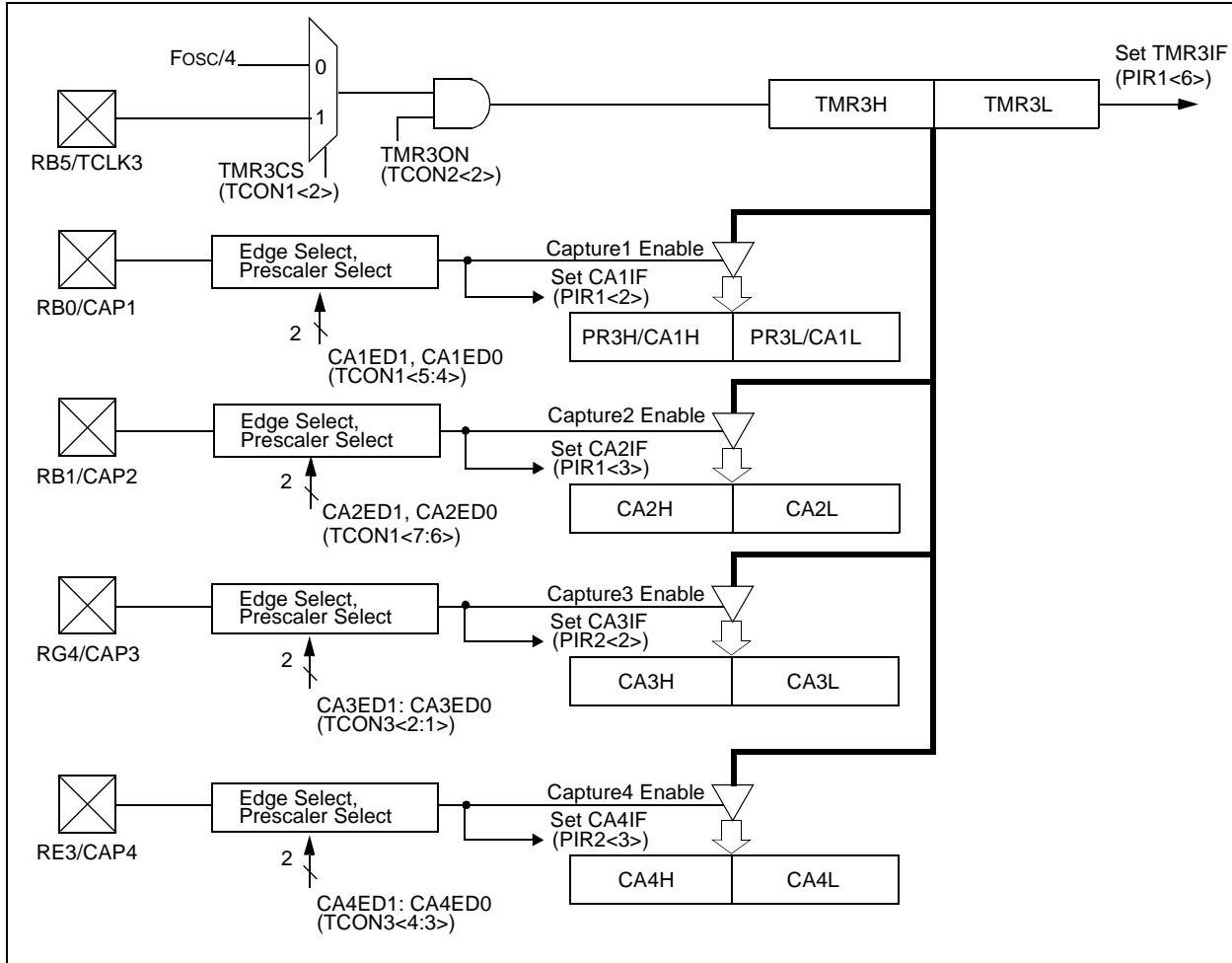

13.2.3 READING THE CAPTURE REGISTERS

The Capture overflow status flag bits are double buffered. The master bit is set if one captured word is already residing in the Capture register and another “event” has occurred on the CAPx pin. The new event will not transfer the TMR3 value to the capture register, protecting the previous unread capture value. When the user reads both the high and the low bytes (in any

order) of the Capture register, the master overflow bit is transferred to the slave overflow bit (CAxOVF) and then the master bit is reset. The user can then read TCONx to determine the value of CAxOVF.

An example of an instruction sequence to read capture registers and capture overflow flag bits is shown in Example 13-1. Depending on the capture source, different registers will need to be read.

EXAMPLE 13-1: SEQUENCE TO READ CAPTURE REGISTERS

MOVLB 3	; Select Bank 3
MOVFPF CA2L, LO_BYTE	; Read Capture2 low byte, store in LO_BYTE
MOVFPF CA2H, HI_BYTE	; Read Capture2 high byte, store in HI_BYTE
MOVFPF TCON2, STAT_VAL	; Read TCON2 into file STAT_VAL

TABLE 13-6: REGISTERS ASSOCIATED WITH CAPTURE

Address	Name	Bit 7	Bit 6	Bit 5	Bit 4	Bit 3	Bit 2	Bit 1	Bit 0	Value on POR, BOR	MCLR, WDT
16h, Bank 3	TCON1	CA2ED1	CA2ED0	CA1ED1	CA1ED0	T16	TMR3CS	TMR2CS	TMR1CS	0000 0000	0000 0000
17h, Bank 3	TCON2	CA2OVF	CA1OVF	PWM2ON	PWM1ON	CA1/PR3	TMR3ON	TMR2ON	TMR1ON	0000 0000	0000 0000
16h, Bank 7	TCON3	—	CA4OVF	CA3OVF	CA4ED1	CA4ED0	CA3ED1	CA3ED0	PWM3ON	-000 0000	-000 0000
12h, Bank 2	TMR3L	Holding Register for the Low Byte of the 16-bit TMR3 Register								xxxx xxxx	uuuu uuuu
13h, Bank 2	TMR3H	Holding Register for the High Byte of the 16-bit TMR3 Register								xxxx xxxx	uuuu uuuu
16h, Bank 1	PIR1	RBIF	TMR3IF	TMR2IF	TMR1IF	CA2IF	CA1IF	TX1IF	RC1IF	x000 0010	u000 0010
17h, Bank 1	PIE1	RBIE	TMR3IE	TMR2IE	TMR1IE	CA2IE	CA1IE	TX1IE	RC1IE	0000 0000	0000 0000
10h, Bank 4	PIR2	SSPIF	BCLIF	ADIF	—	CA4IF	CA3IF	TX2IF	RC2IF	000- 0010	000- 0010
11h, Bank 4	PIE2	SSPIE	BCLIE	ADIE	—	CA4IE	CA3IE	TX2IE	RC2IE	000- 0000	000- 0000
07h, Unbanked	INTSTA	PEIF	T0CKIF	T0IF	INTF	PEIE	T0CKIE	T0IE	INTE	0000 0000	0000 0000
06h, Unbanked	CPUSTA	—	—	STKAV	GLINTD	\overline{TO}	\overline{PD}	\overline{POR}	\overline{BOR}	--11 11qq	--11 qquu
16h, Bank 2	PR3L/CA1L	Timer3 Period Register, Low Byte/Capture1 Register, Low Byte								xxxx xxxx	uuuu uuuu
17h, Bank 2	PR3H/CA1H	Timer3 Period Register, High Byte/Capture1 Register, High Byte								xxxx xxxx	uuuu uuuu
14h, Bank 3	CA2L	Capture2 Low Byte								xxxx xxxx	uuuu uuuu
15h, Bank 3	CA2H	Capture2 High Byte								xxxx xxxx	uuuu uuuu
12h, Bank 7	CA3L	Capture3 Low Byte								xxxx xxxx	uuuu uuuu
13h, Bank 7	CA3H	Capture3 High Byte								xxxx xxxx	uuuu uuuu
14h, Bank 7	CA4L	Capture4 Low Byte								xxxx xxxx	uuuu uuuu
15h, Bank 7	CA4H	Capture4 High Byte								xxxx xxxx	uuuu uuuu

Legend: x = unknown, u = unchanged, - = unimplemented, read as '0', q = value depends on condition.
Shaded cells are not used by Capture.

PIC17C7XX

13.2.4 EXTERNAL CLOCK INPUT FOR TIMER3

When TMR3CS is set, the 16-bit TMR3 increments on the falling edge of clock input TCLK3. The input on the RB5/TCLK3 pin is sampled and synchronized by the internal phase clocks, twice every instruction cycle. This causes a delay from the time a falling edge appears on TCLK3 to the time TMR3 is actually incremented. For the external clock input timing requirements, see the Electrical Specification section. Figure 13-7 shows the timing diagram when operating from an external clock.

13.2.5 READING/WRITING TIMER3

Since Timer3 is a 16-bit timer and only 8-bits at a time can be read or written, care should be taken when reading or writing while the timer is running. The best method is to stop the timer, perform any read or write operation and then restart Timer3 (using the TMR3ON bit). However, if it is necessary to keep Timer3 free-running, care must be taken. For writing to the 16-bit TMR3, Example 13-2 may be used. For reading the 16-bit TMR3, Example 13-3 may be used. Interrupts must be disabled during this routine.

EXAMPLE 13-2: WRITING TO TMR3

```
BSF    CPUSTA, GLINTD    ; Disable interrupts
MOVFP  RAM_L,  TMR3L     ;
MOVFP  RAM_H,  TMR3H     ;
BCF    CPUSTA, GLINTD    ; Done, enable interrupts
```

EXAMPLE 13-3: READING FROM TMR3

```
MOVFP  TMR3L, TMPLO     ; read low TMR3
MOVFP  TMR3H, TMPHI     ; read high TMR3
MOVFP  TMPLO, WREG      ; tmplo -> wreg
CPFSLT TMR3L           ; TMR3L < wreg?
RETURN                               ; no then return
MOVFP  TMR3L, TMPLO     ; read low TMR3
MOVFP  TMR3H, TMPHI     ; read high TMR3
RETURN                               ; return
```

FIGURE 13-7: TIMER1, TIMER2 AND TIMER3 OPERATION (IN COUNTER MODE)

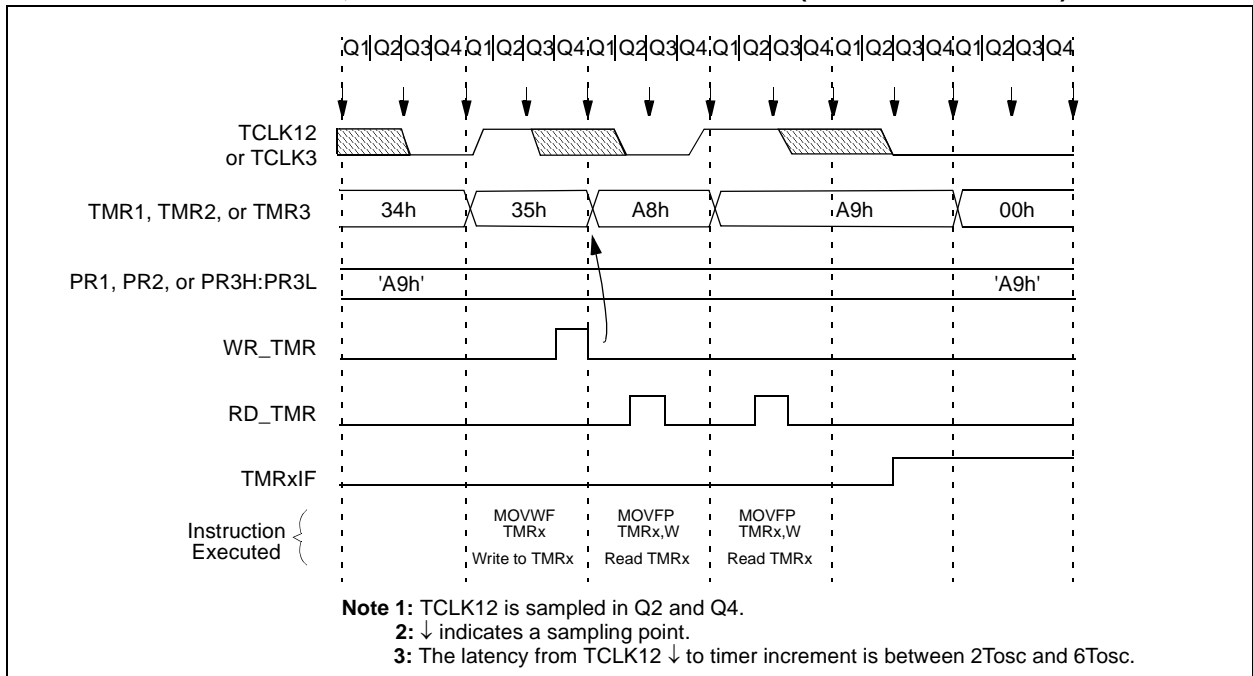
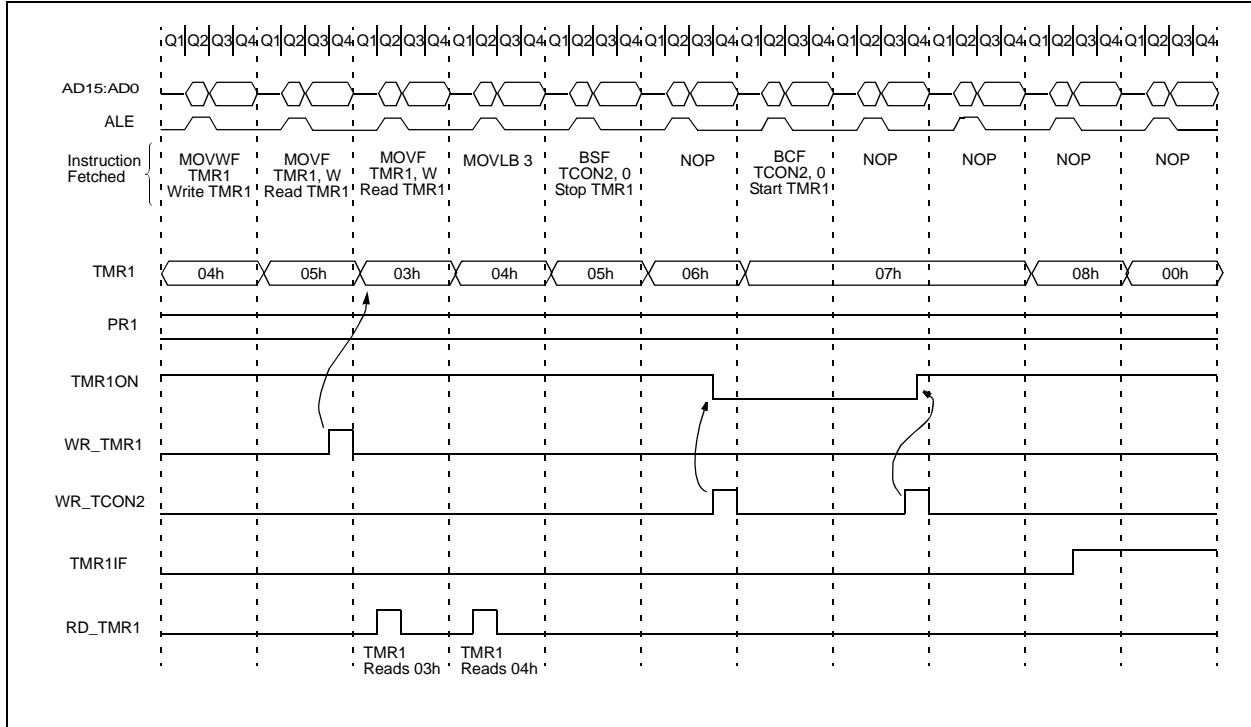

FIGURE 13-8: TIMER1, TIMER2 AND TIMER3 OPERATION (IN TIMER MODE)



PIC17C7XX

NOTES:

14.0 UNIVERSAL SYNCHRONOUS ASYNCHRONOUS RECEIVER TRANSMITTER (USART) MODULES

Each USART module is a serial I/O module. There are two USART modules that are available on the PIC17C7XX. They are specified as USART1 and USART2. The description of the operation of these modules is generic in regard to the register names and pin names used. Table 14-1 shows the generic names that are used in the description of operation and the actual names for both USART1 and USART2. Since the control bits in each register have the same function, their names are the same (there is no need to differentiate).

The Transmit Status and Control Register (TXSTA) is shown in Figure 14-1, while the Receive Status and Control Register (RCSTA) is shown in Figure 14-2.

TABLE 14-1: USART MODULE GENERIC NAMES

Generic Name	USART1 Name	USART2 Name
<i>Registers</i>		
RCSTA	RCSTA1	RCSTA2
TXSTA	TXSTA1	TXSTA2
SPBRG	SPBRG1	SPBRG2
RCREG	RCREG1	RCREG2
TXREG	TXREG1	TXREG2
<i>Interrupt Control Bits</i>		
RCIE	RC1IE	RC2IE
RCIF	RC1IF	RC2IF
TXIE	TX1IE	TX2IE
TXIF	TX1IF	TX2IF
<i>Pins</i>		
RX/DT	RA4/RX1/DT1	RG6/RX2/DT2
TX/CK	RA5/TX1/CK1	RG7/TX2/CK2

**REGISTER 14-1: TXSTA1 REGISTER (ADDRESS: 15h, BANK 0)
TXSTA2 REGISTER (ADDRESS: 15h, BANK 4)**

R/W-0	R/W-0	R/W-0	R/W-0	U-0	U-0	R-1	R/W-x	
CSRC	TX9	TXEN	SYNC	—	—	TRMT	TX9D	
			bit 7					bit 0

bit 7 **CSRC:** Clock Source Select bit

Synchronous mode:

- 1 = Master mode (clock generated internally from BRG)
- 0 = Slave mode (clock from external source)

Asynchronous mode:

Don't care

bit 6 **TX9:** 9-bit Transmit Select bit
1 = Selects 9-bit transmission
0 = Selects 8-bit transmission

bit 5 **TXEN:** Transmit Enable bit
1 = Transmit enabled
0 = Transmit disabled
SREN/CREN overrides TXEN in SYNC mode

bit 4 **SYNC:** USART Mode Select bit
(Synchronous/Asynchronous)
1 = Synchronous mode
0 = Asynchronous mode

bit 3-2 **Unimplemented:** Read as '0'

bit 1 **TRMT:** Transmit Shift Register (TSR) Empty bit
1 = TSR empty
0 = TSR full

bit 0 **TX9D:** 9th bit of Transmit Data (can be used to calculate the parity in software)

Legend:

R = Readable bit	W = Writable bit	U = Unimplemented bit, read as '0'
- n = Value at POR Reset	'1' = Bit is set	'0' = Bit is cleared
		x = Bit is unknown

PIC17C7XX

The USART can be configured as a full duplex asynchronous system that can communicate with peripheral devices such as CRT terminals and personal computers, or it can be configured as a half duplex synchronous system that can communicate with peripheral devices such as A/D or D/A integrated circuits, Serial EEPROMs etc. The USART can be configured in the following modes:

- Asynchronous (full duplex)
- Synchronous - Master (half duplex)
- Synchronous - Slave (half duplex)

The SPEN (RCSTA<7>) bit has to be set in order to configure the I/O pins as the Serial Communication Interface (USART).

The USART module will control the direction of the RX/DT and TX/CK pins, depending on the states of the USART configuration bits in the RCSTA and TXSTA registers. The bits that control I/O direction are:

- SPEN
- TXEN
- SREN
- CREN
- CSRC

REGISTER 14-2: RCSTA1 REGISTER (ADDRESS: 13h, BANK 0) RCSTA2 REGISTER (ADDRESS: 13h, BANK 4)

R/W-0	R/W-0	R/W-0	R/W-0	U-0	R-0	R-0	R-x
SPEN	RX9	SREN	CREN	—	FERR	OERR	RX9D
							bit 0
							bit 7

- bit 7 **SPEN:** Serial Port Enable bit
1 = Configures TX/CK and RX/DT pins as serial port pins
0 = Serial port disabled
- bit 6 **RX9:** 9-bit Receive Select bit
1 = Selects 9-bit reception
0 = Selects 8-bit reception
- bit 5 **SREN:** Single Receive Enable bit
This bit enables the reception of a single byte. After receiving the byte, this bit is automatically cleared.
Synchronous mode:
1 = Enable reception
0 = Disable reception
Note: This bit is ignored in synchronous slave reception.
Asynchronous mode:
Don't care
- bit 4 **CREN:** Continuous Receive Enable bit
This bit enables the continuous reception of serial data.
Asynchronous mode:
1 = Enable continuous reception
0 = Disables continuous reception
Synchronous mode:
1 = Enables continuous reception until CREN is cleared (CREN overrides SREN)
0 = Disables continuous reception
- bit 3 **Unimplemented:** Read as '0'
- bit 2 **FERR:** Framing Error bit
1 = Framing error (updated by reading RCREG)
0 = No framing error
- bit 1 **OERR:** Overrun Error bit
1 = Overrun (cleared by clearing CREN)
0 = No overrun error
- bit 0 **RX9D:** 9th bit of Receive Data (can be the software calculated parity bit)

Legend:			
R = Readable bit	W = Writable bit	U = Unimplemented bit, read as '0'	
- n = Value at POR Reset	'1' = Bit is set	'0' = Bit is cleared	x = Bit is unknown

FIGURE 14-1: USART TRANSMIT

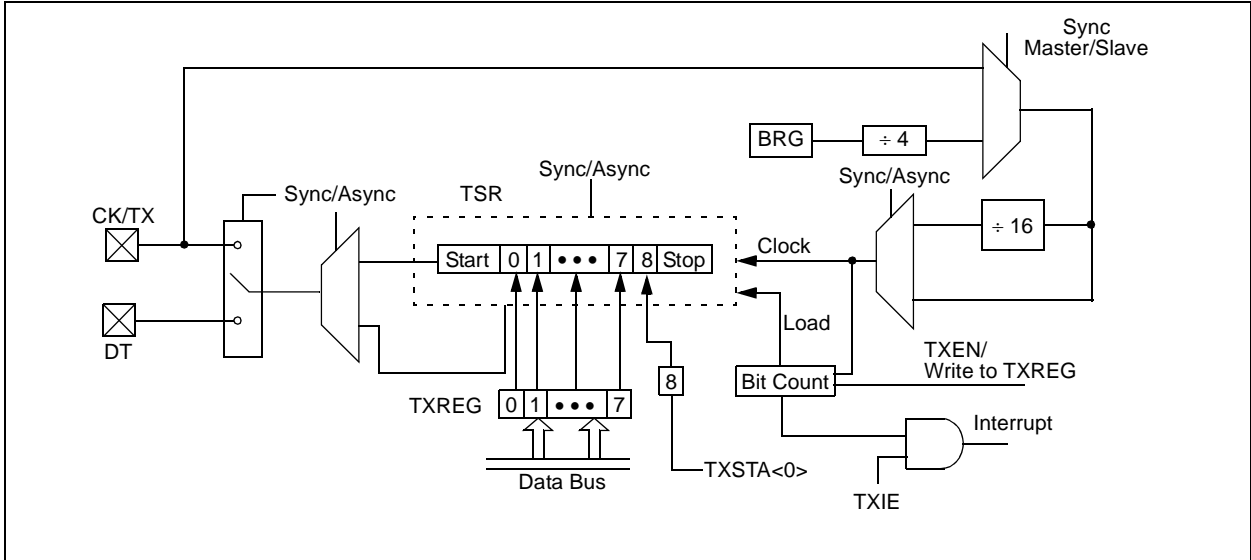
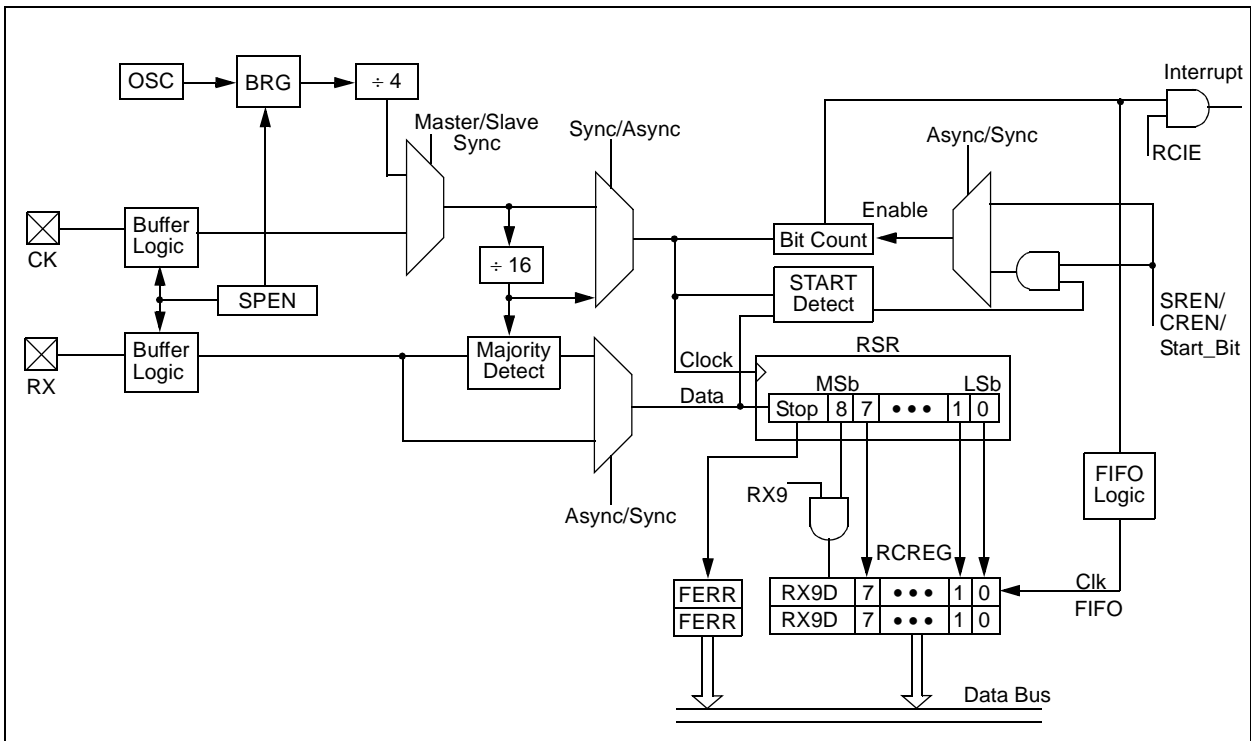

FIGURE 14-2: USART RECEIVE



PIC17C7XX

14.1 USART Baud Rate Generator (BRG)

The BRG supports both the Asynchronous and Synchronous modes of the USART. It is a dedicated 8-bit baud rate generator. The SPBRG register controls the period of a free running 8-bit timer. Table 14-2 shows the formula for computation of the baud rate for different USART modes. These only apply when the USART is in Synchronous Master mode (internal clock) and Asynchronous mode.

Given the desired baud rate and Fosc, the nearest integer value between 0 and 255 can be calculated using the formula below. The error in baud rate can then be determined.

TABLE 14-2: BAUD RATE FORMULA

SYNC	Mode	Baud Rate
0	Asynchronous	$F_{osc}/(64(X+1))$
1	Synchronous	$F_{osc}/(4(X+1))$

X = value in SPBRG (0 to 255)

Example 14-1 shows the calculation of the baud rate error for the following conditions:

FOSC = 16 MHz
 Desired Baud Rate = 9600
 SYNC = 0

EXAMPLE 14-1: CALCULATING BAUD RATE ERROR

$$\begin{aligned}
 \text{Desired Baud Rate} &= F_{osc} / (64 (X + 1)) \\
 9600 &= 16000000 / (64 (X + 1)) \\
 X &= 25.042 \rightarrow 25 \\
 \text{Calculated Baud Rate} &= 16000000 / (64 (25 + 1)) \\
 &= 9615 \\
 \text{Error} &= \frac{(\text{Calculated Baud Rate} - \text{Desired Baud Rate})}{\text{Desired Baud Rate}} \\
 &= (9615 - 9600) / 9600 \\
 &= 0.16\%
 \end{aligned}$$

Writing a new value to the SPBRG, causes the BRG timer to be reset (or cleared). This ensures that the BRG does not wait for a timer overflow before outputting the new baud rate.

Effects of Reset

After any device RESET, the SPBRG register is cleared. The SPBRG register will need to be loaded with the desired value after each RESET.

TABLE 14-3: REGISTERS ASSOCIATED WITH BAUD RATE GENERATOR

	Address	Name	Bit 7	Bit 6	Bit 5	Bit 4	Bit 3	Bit 2	Bit 1	Bit 0	Value on POR, BOR	MCLR, WDT
USART1	13h, Bank 0	RCSTA1	SPEN	RX9	SREN	CREN	—	FERR	OERR	RX9D	0000 -00x	0000 -00u
	15h, Bank 0	TXSTA1	CSRC	TX9	TXEN	SYNC	—	—	TRMT	TX9D	0000 --1x	0000 --1u
	17h, Bank 0	SPBRG1	Baud Rate Generator Register								0000 0000	0000 0000
USART2	13h, Bank 4	RCSTA2	SPEN	RX9	SREN	CREN	—	FERR	OERR	RX9D	0000 -00x	0000 -00u
	15h, Bank 4	TXSTA2	CSRC	TX9	TXEN	SYNC	—	—	TRMT	TX9D	0000 --1x	0000 --1u
	17h, Bank 4	SPBRG2	Baud Rate Generator Register								0000 0000	0000 0000

Legend: x = unknown, u = unchanged, - = unimplemented, read as '0'. Shaded cells are not used by the Baud Rate Generator.

TABLE 14-4: BAUD RATES FOR SYNCHRONOUS MODE

BAUD RATE (K)	FOSC = 33 MHz			FOSC = 25 MHz			FOSC = 20 MHz			FOSC = 16 MHz		
	KBAUD	%ERROR	SPBRG VALUE (DECIMAL)	KBAUD	%ERROR	SPBRG VALUE (DECIMAL)	KBAUD	%ERROR	SPBRG VALUE (DECIMAL)	KBAUD	%ERROR	SPBRG VALUE (DECIMAL)
0.3	NA	—	—	NA	—	—	NA	—	—	NA	—	—
1.2	NA	—	—	NA	—	—	NA	—	—	NA	—	—
2.4	NA	—	—	NA	—	—	NA	—	—	NA	—	—
9.6	NA	—	—	NA	—	—	NA	—	—	NA	—	—
19.2	NA	—	—	NA	—	—	19.53	+1.73	255	19.23	+0.16	207
76.8	77.10	+0.39	106	77.16	+0.47	80	76.92	+0.16	64	76.92	+0.16	51
96	95.93	-0.07	85	96.15	+0.16	64	96.15	+0.16	51	95.24	-0.79	41
300	294.64	-1.79	27	297.62	-0.79	20	294.1	-1.96	16	307.69	+2.56	12
500	485.29	-2.94	16	480.77	-3.85	12	500	0	9	500	0	7
HIGH	8250	—	0	6250	—	0	5000	—	0	4000	—	0
LOW	32.22	—	255	24.41	—	255	19.53	—	255	15.625	—	255

BAUD RATE (K)	FOSC = 10 MHz			FOSC = 7.159 MHz			FOSC = 5.068 MHz		
	KBAUD	%ERROR	SPBRG VALUE (DECIMAL)	KBAUD	%ERROR	SPBRG VALUE (DECIMAL)	KBAUD	%ERROR	SPBRG VALUE (DECIMAL)
0.3	NA	—	—	NA	—	—	NA	—	—
1.2	NA	—	—	NA	—	—	NA	—	—
2.4	NA	—	—	NA	—	—	NA	—	—
9.6	9.766	+1.73	255	9.622	+0.23	185	9.6	0	131
19.2	19.23	+0.16	129	19.24	+0.23	92	19.2	0	65
76.8	75.76	-1.36	32	77.82	+1.32	22	79.2	+3.13	15
96	96.15	+0.16	25	94.20	-1.88	18	97.48	+1.54	12
300	312.5	+4.17	7	298.3	-0.57	5	316.8	+5.60	3
500	500	0	4	NA	—	—	NA	—	—
HIGH	2500	—	0	1789.8	—	0	1267	—	0
LOW	9.766	—	255	6.991	—	255	4.950	—	255

BAUD RATE (K)	Fosc = 3.579 MHz			FOSC = 1 MHz			FOSC = 32.768 kHz		
	KBAUD	%ERROR	SPBRG VALUE (DECIMAL)	KBAUD	%ERROR	SPBRG VALUE (DECIMAL)	KBAUD	%ERROR	SPBRG VALUE (DECIMAL)
0.3	NA	—	—	NA	—	—	0.303	+1.14	26
1.2	NA	—	—	1.202	+0.16	207	1.170	-2.48	6
2.4	NA	—	—	2.404	+0.16	103	NA	—	—
9.6	9.622	+0.23	92	9.615	+0.16	25	NA	—	—
19.2	19.04	-0.83	46	19.24	+0.16	12	NA	—	—
76.8	74.57	-2.90	11	83.34	+8.51	2	NA	—	—
96	99.43	-3.57	8	NA	—	—	NA	—	—
300	298.3	-0.57	2	NA	—	—	NA	—	—
500	NA	—	—	NA	—	—	NA	—	—
HIGH	894.9	—	0	250	—	0	8.192	—	0
LOW	3.496	—	255	0.976	—	255	0.032	—	255

PIC17C7XX

TABLE 14-5: BAUD RATES FOR ASYNCHRONOUS MODE

BAUD RATE (K)	FOSC = 33 MHz			FOSC = 25 MHz			FOSC = 20 MHz			FOSC = 16 MHz		
	KBAUD	%ERROR	SPBRG VALUE (DECIMAL)	KBAUD	%ERROR	SPBRG VALUE (DECIMAL)	KBAUD	%ERROR	SPBRG VALUE (DECIMAL)	KBAUD	%ERROR	SPBRG VALUE (DECIMAL)
0.3	NA	—	—	NA	—	—	NA	—	—	NA	—	—
1.2	NA	—	—	NA	—	—	1.221	+1.73	255	1.202	+0.16	207
2.4	2.398	-0.07	214	2.396	0.14	162	2.404	+0.16	129	2.404	+0.16	103
9.6	9.548	-0.54	53	9.53	-0.76	40	9.469	-1.36	32	9.615	+0.16	25
19.2	19.09	-0.54	26	19.53	+1.73	19	19.53	+1.73	15	19.23	+0.16	12
76.8	73.66	-4.09	6	78.13	+1.73	4	78.13	+1.73	3	83.33	+8.51	2
96	103.12	+7.42	4	97.65	+1.73	3	104.2	+8.51	2	NA	—	—
300	257.81	-14.06	1	390.63	+30.21	0	312.5	+4.17	0	NA	—	—
500	515.62	+3.13	0	NA	—	—	NA	—	—	NA	—	—
HIGH	515.62	—	0	—	—	0	312.5	—	0	250	—	0
LOW	2.014	—	255	1.53	—	255	1.221	—	255	0.977	—	255

BAUD RATE (K)	Fosc = 10 MHz			FOSC = 7.159 MHz			FOSC = 5.068 MHz		
	KBAUD	%ERROR	SPBRG VALUE (DECIMAL)	KBAUD	%ERROR	SPBRG VALUE (DECIMAL)	KBAUD	%ERROR	SPBRG VALUE (DECIMAL)
0.3	NA	—	—	NA	—	—	0.31	+3.13	255
1.2	1.202	+0.16	129	1.203	-0.23	92	1.2	0	65
2.4	2.404	+0.16	64	2.380	-0.83	46	2.4	0	32
9.6	9.766	+1.73	15	9.322	-2.90	11	9.9	-3.13	7
19.2	19.53	+1.73	7	18.64	-2.90	5	19.8	+3.13	3
76.8	78.13	+1.73	1	NA	—	—	79.2	+3.13	0
96	NA	—	—	NA	—	—	NA	—	—
300	NA	—	—	NA	—	—	NA	—	—
500	NA	—	—	NA	—	—	NA	—	—
HIGH	156.3	—	0	111.9	—	0	79.2	—	0
LOW	0.610	—	255	0.437	—	255	0.309	—	255

BAUD RATE (K)	Fosc = 3.579 MHz			FOSC = 1 MHz			FOSC = 32.768 kHz		
	KBAUD	%ERROR	SPBRG VALUE (DECIMAL)	KBAUD	%ERROR	SPBRG VALUE (DECIMAL)	KBAUD	%ERROR	SPBRG VALUE (DECIMAL)
0.3	0.301	+0.23	185	0.300	+0.16	51	0.256	-14.67	1
1.2	1.190	-0.83	46	1.202	+0.16	12	NA	—	—
2.4	2.432	+1.32	22	2.232	-6.99	6	NA	—	—
9.6	9.322	-2.90	5	NA	—	—	NA	—	—
19.2	18.64	-2.90	2	NA	—	—	NA	—	—
76.8	NA	—	—	NA	—	—	NA	—	—
96	NA	—	—	NA	—	—	NA	—	—
300	NA	—	—	NA	—	—	NA	—	—
500	NA	—	—	NA	—	—	NA	—	—
HIGH	55.93	—	0	15.63	—	0	0.512	—	0
LOW	0.218	—	255	0.061	—	255	0.002	—	255

14.2 USART Asynchronous Mode

In this mode, the USART uses standard nonreturn-to-zero (NRZ) format (one START bit, eight or nine data bits, and one STOP bit). The most common data format is 8-bits. An on-chip dedicated 8-bit baud rate generator can be used to derive standard baud rate frequencies from the oscillator. The USART's transmitter and receiver are functionally independent but use the same data format and baud rate. The baud rate generator produces a clock x64 of the bit shift rate. Parity is not supported by the hardware, but can be implemented in software (and stored as the ninth data bit). Asynchronous mode is stopped during SLEEP.

The Asynchronous mode is selected by clearing the SYNC bit (TXSTA<4>).

The USART Asynchronous module consists of the following components:

- Baud Rate Generator
- Sampling Circuit
- Asynchronous Transmitter
- Asynchronous Receiver

14.2.1 USART ASYNCHRONOUS TRANSMITTER

The USART transmitter block diagram is shown in Figure 14-1. The heart of the transmitter is the transmit shift register (TSR). The shift register obtains its data from the read/write transmit buffer (TXREG). TXREG is loaded with data in software. The TSR is not loaded until the STOP bit has been transmitted from the previous load. As soon as the STOP bit is transmitted, the TSR is loaded with new data from the TXREG (if available). Once TXREG transfers the data to the TSR (occurs in one T_{CY} at the end of the current BRG cycle), the TXREG is empty and an interrupt bit, TXIF, is set. This interrupt can be enabled/disabled by setting/clearing the TXIE bit. TXIF will be set, regardless of TXIE and cannot be reset in software. It will reset only when new data is loaded into TXREG. While TXIF indicates the status of the TXREG, the TRMT (TXSTA<1>) bit shows the status of the TSR.

TRMT is a read only bit which is set when the TSR is empty. No interrupt logic is tied to this bit, so the user has to poll this bit in order to determine if the TSR is empty.

Note: The TSR is not mapped in data memory, so it is not available to the user.

Transmission is enabled by setting the TXEN (TXSTA<5>) bit. The actual transmission will not occur until TXREG has been loaded with data and the baud rate generator (BRG) has produced a shift clock (Figure 14-3). The transmission can also be started by first loading TXREG and then setting TXEN. Normally, when transmission is first started, the TSR is empty, so a transfer to TXREG will result in an immediate transfer to TSR, resulting in an empty TXREG. A back-to-back transfer is thus possible (Figure 14-4). Clearing TXEN during a transmission will cause the transmission to be aborted. This will reset the transmitter and the TX/CK pin will revert to hi-impedance.

In order to select 9-bit transmission, the TX9 (TXSTA<6>) bit should be set and the ninth bit value should be written to TX9D (TXSTA<0>). The ninth bit value must be written before writing the 8-bit data to the TXREG. This is because a data write to TXREG can result in an immediate transfer of the data to the TSR (if the TSR is empty).

Steps to follow when setting up an Asynchronous Transmission:

1. Initialize the SPBRG register for the appropriate baud rate.
2. Enable the asynchronous serial port by clearing the SYNC bit and setting the SPEN bit.
3. If interrupts are desired, then set the TXIE bit.
4. If 9-bit transmission is desired, then set the TX9 bit.
5. If 9-bit transmission is selected, the ninth bit should be loaded in TX9D.
6. Load data to the TXREG register.
7. Enable the transmission by setting TXEN (starts transmission).

FIGURE 14-3: ASYNCHRONOUS MASTER TRANSMISSION

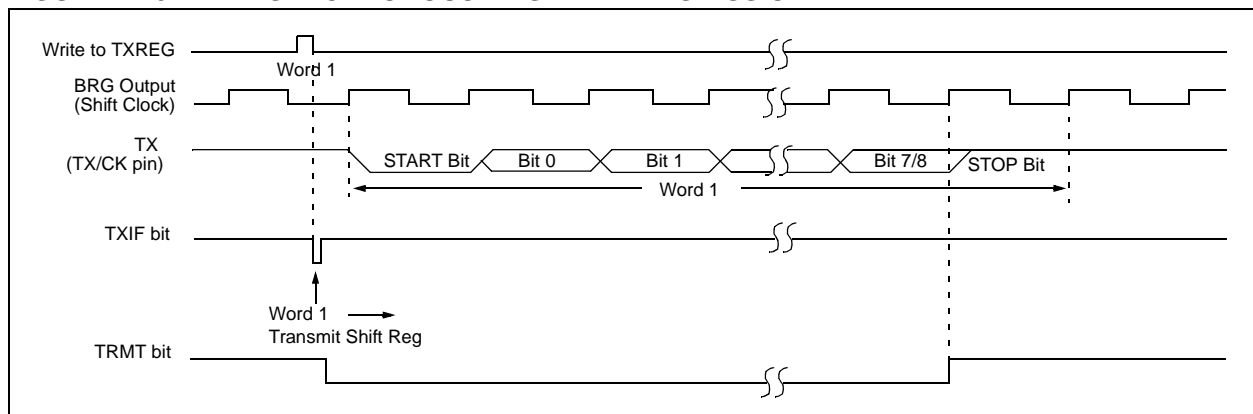

PIC17C7XX

FIGURE 14-4: ASYNCHRONOUS MASTER TRANSMISSION (BACK TO BACK)

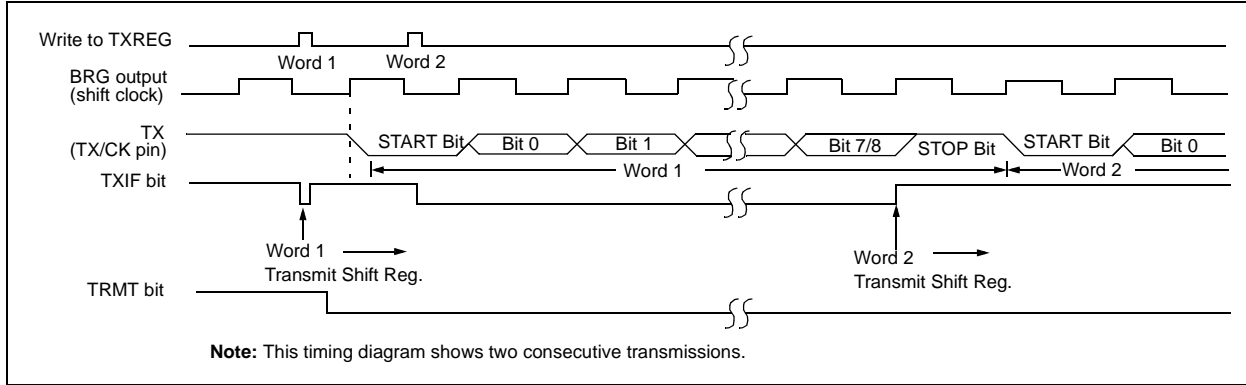

TABLE 14-6: REGISTERS ASSOCIATED WITH ASYNCHRONOUS TRANSMISSION

Address	Name	Bit 7	Bit 6	Bit 5	Bit 4	Bit 3	Bit 2	Bit 1	Bit 0	Value on POR, BOR	MCLR, WDT
16h, Bank 1	PIR1	RBIF	TMR3IF	TMR2IF	TMR1IF	CA2IF	CA1IF	TX1IF	RC1IF	x000 0010	u000 0010
17h, Bank 1	PIE1	RBIE	TMR3IE	TMR2IE	TMR1IE	CA2IE	CA1IE	TX1IE	RC1IE	0000 0000	0000 0000
13h, Bank 0	RCSTA1	SPEN	RX9	SREN	CREN	—	FERR	OERR	RX9D	0000 -00x	0000 -00u
16h, Bank 0	TXREG1	Serial Port Transmit Register (USART1)								xxxx xxxx	uuuu uuuu
15h, Bank 0	TXSTA1	CSRC	TX9	TXEN	SYNC	—	—	TRMT	TX9D	0000 --1x	0000 --1u
17h, Bank 0	SPBRG1	Baud Rate Generator Register (USART1)								0000 0000	0000 0000
10h, Bank 4	PIR2	SSPIF	BCLIF	ADIF	—	CA4IF	CA3IF	TX2IF	RC2IF	000- 0010	000- 0010
11h, Bank 4	PIE2	SSPIE	BCLIE	ADIE	—	CA4IE	CA3IE	TX2IE	RC2IE	000- 0000	000- 0000
13h, Bank 4	RCSTA2	SPEN	RX9	SREN	CREN	—	FERR	OERR	RX9D	0000 -00x	0000 -00u
16h, Bank 4	TXREG2	Serial Port Transmit Register (USART2)								xxxx xxxx	uuuu uuuu
15h, Bank 4	TXSTA2	CSRC	TX9	TXEN	SYNC	—	—	TRMT	TX9D	0000 --1x	0000 --1u
17h, Bank 4	SPBRG2	Baud Rate Generator Register (USART2)								0000 0000	0000 0000

Legend: x = unknown, u = unchanged, - = unimplemented, read as a '0'. Shaded cells are not used for asynchronous transmission.

14.2.2 USART ASYNCHRONOUS RECEIVER

The receiver block diagram is shown in Figure 14-2. The data comes in the RX/DT pin and drives the data recovery block. The data recovery block is actually a high speed shifter operating at 16 times the baud rate, whereas the main receive serial shifter operates at the bit rate or at FOSC.

Once Asynchronous mode is selected, reception is enabled by setting bit CREN (RCSTA<4>).

The heart of the receiver is the receive (serial) shift register (RSR). After sampling the STOP bit, the received data in the RSR is transferred to the RCREG (if it is empty). If the transfer is complete, the interrupt bit, RCIF, is set. The actual interrupt can be enabled/disabled by setting/clearing the RCIE bit. RCIF is a read only bit which is cleared by the hardware. It is cleared when RCREG has been read and is empty. RCREG is a double buffered register (i.e., it is a two-deep FIFO). It is possible for two bytes of data to be received and transferred to the RCREG FIFO and a third byte begin shifting to the RSR. On detection of the STOP bit of the third byte, if the RCREG is still full, then the overrun error bit, OERR (RCSTA<1>) will be set. The word in the RSR will be lost. RCREG can be read twice to retrieve the two bytes in the FIFO. The OERR bit has to be cleared in software which is done by reset-

ting the receive logic (CREN is set). If the OERR bit is set, transfers from the RSR to RCREG are inhibited, so it is essential to clear the OERR bit if it is set. The framing error bit FERR (RCSTA<2>) is set if a STOP bit is not detected.

Note: The FERR and the 9th receive bit are buffered the same way as the receive data. Reading the RCREG register will allow the RX9D and FERR bits to be loaded with values for the next received data. Therefore, it is essential for the user to read the RCSTA register before reading RCREG, in order not to lose the old FERR and RX9D information.

14.2.3 SAMPLING

The data on the RX/DT pin is sampled three times by a majority detect circuit to determine if a high or a low level is present at the RX/DT pin. The sampling is done on the seventh, eighth and ninth falling edges of a x16 clock (Figure 14-5).

The x16 clock is a free running clock and the three sample points occur at a frequency of every 16 falling edges.

FIGURE 14-5: RX PIN SAMPLING SCHEME

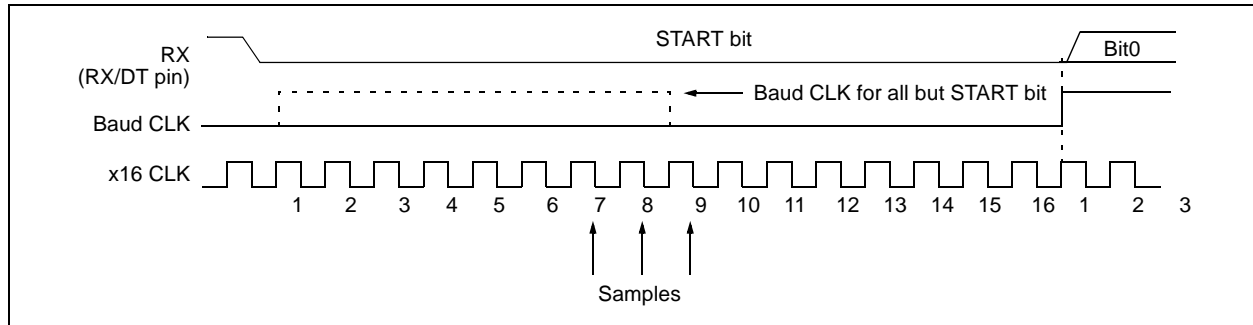
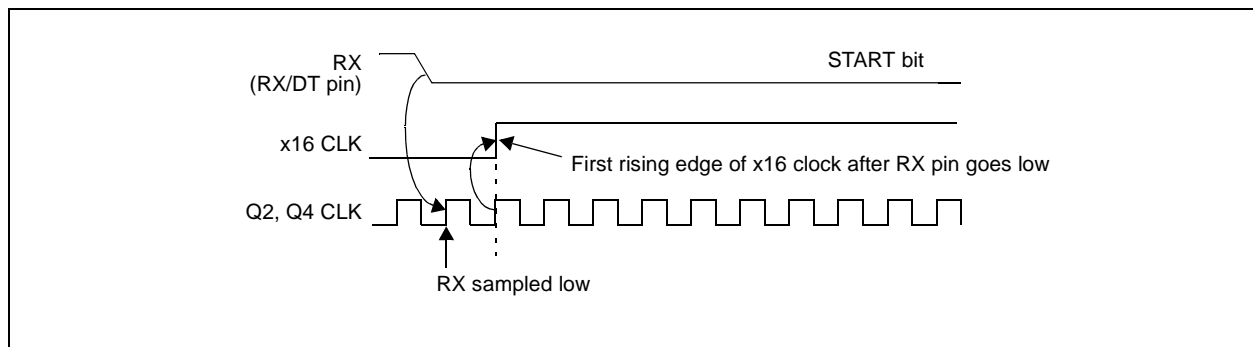

FIGURE 14-6: START BIT DETECT



PIC17C7XX

Steps to follow when setting up an Asynchronous Reception:

1. Initialize the SPBRG register for the appropriate baud rate.
2. Enable the asynchronous serial port by clearing the SYNC bit and setting the SPEN bit.
3. If interrupts are desired, then set the RCIE bit.
4. If 9-bit reception is desired, then set the RX9 bit.
5. Enable the reception by setting the CREN bit.
6. The RCIF bit will be set when reception completes and an interrupt will be generated if the RCIE bit was set.

7. Read RCSTA to get the ninth bit (if enabled) and FERR bit to determine if any error occurred during reception.
8. Read RCREG for the 8-bit received data.
9. If an overrun error occurred, clear the error by clearing the OERR bit.

Note: To terminate a reception, either clear the SREN and CREN bits, or the SPEN bit. This will reset the receive logic, so that it will be in the proper state when receive is re-enabled.

FIGURE 14-7: ASYNCHRONOUS RECEPTION

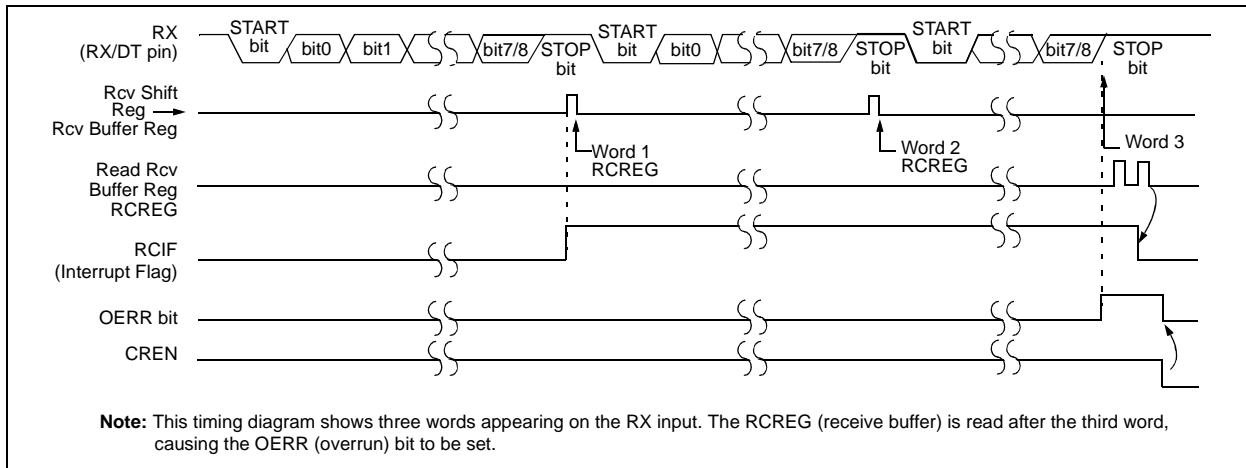

TABLE 14-7: REGISTERS ASSOCIATED WITH ASYNCHRONOUS RECEPTION

Address	Name	Bit 7	Bit 6	Bit 5	Bit 4	Bit 3	Bit 2	Bit 1	Bit 0	Value on POR, BOR	MCLR, WDT
16h, Bank 1	PIR1	RBIF	TMR3IF	TMR2IF	TMR1IF	CA2IF	CA1IF	TX1IF	RC1IF	x000 0010	u000 0010
17h, Bank 1	PIE1	RBIE	TMR3IE	TMR2IE	TMR1IE	CA2IE	CA1IE	TX1IE	RC1IE	0000 0000	0000 0000
13h, Bank 0	RCSTA1	SPEN	RX9	SREN	CREN	—	FERR	OERR	RX9D	0000 -00x	0000 -00u
14h, Bank 0	RCREG1	RX7	RX6	RX5	RX4	RX3	RX2	RX1	RX0	xxxx xxxx	uuuu uuuu
15h, Bank 0	TXSTA1	CSRC	TX9	TXEN	SYNC	—	—	TRMT	TX9D	0000 --1x	0000 --1u
17h, Bank 0	SPBRG1	Baud Rate Generator Register								0000 0000	0000 0000
10h, Bank 4	PIR2	SSPIF	BCLIF	ADIF	—	CA4IF	CA3IF	TX2IF	RC2IF	000- 0010	000- 0010
11h, Bank 4	PIE2	SSPIE	BCLIE	ADIE	—	CA4IE	CA3IE	TX2IE	RC2IE	000- 0000	000- 0000
13h, Bank 4	RCSTA2	SPEN	RX9	SREN	CREN	—	FERR	OERR	RX9D	0000 -00x	0000 -00u
14h, Bank 4	RCREG2	RX7	RX6	RX5	RX4	RX3	RX2	RX1	RX0	xxxx xxxx	uuuu uuuu
15h, Bank 4	TXSTA2	CSRC	TX9	TXEN	SYNC	—	—	TRMT	TX9D	0000 --1x	0000 --1u
17h, Bank 4	SPBRG2	Baud Rate Generator Register								0000 0000	0000 0000

Legend: x = unknown, u = unchanged, - = unimplemented, read as a '0'. Shaded cells are not used for asynchronous reception.

14.3 USART Synchronous Master Mode

In Master Synchronous mode, the data is transmitted in a half-duplex manner; i.e., transmission and reception do not occur at the same time: when transmitting data, the reception is inhibited and vice versa. The synchronous mode is entered by setting the SYNC (TXSTA<4>) bit. In addition, the SPEN (RCSTA<7>) bit is set in order to configure the I/O pins to CK (clock) and DT (data) lines, respectively. The Master mode indicates that the processor transmits the master clock on the CK line. The Master mode is entered by setting the CSRC (TXSTA<7>) bit.

14.3.1 USART SYNCHRONOUS MASTER TRANSMISSION

The USART transmitter block diagram is shown in Figure 14-1. The heart of the transmitter is the transmit (serial) shift register (TSR). The shift register obtains its data from the read/write transmit buffer TXREG. TXREG is loaded with data in software. The TSR is not loaded until the last bit has been transmitted from the previous load. As soon as the last bit is transmitted, the TSR is loaded with new data from TXREG (if available). Once TXREG transfers the data to the TSR (occurs in one T_{cy} at the end of the current BRG cycle), TXREG is empty and the TXIF bit is set. This interrupt can be enabled/disabled by setting/clearing the TXIE bit. TXIF will be set regardless of the state of bit TXIE and cannot be cleared in software. It will reset only when new data is loaded into TXREG. While TXIF indicates the status of TXREG, TRMT (TXSTA<1>) shows the status of the TSR. TRMT is a read only bit which is set when the TSR is empty. No interrupt logic is tied to this bit, so the user has to poll this bit in order to determine if the TSR is empty. The TSR is not mapped in data memory, so it is not available to the user.

Transmission is enabled by setting the TXEN (TXSTA<5>) bit. The actual transmission will not occur until TXREG has been loaded with data. The first data bit will be shifted out on the next available rising edge of the clock on the TX/CK pin. Data out is stable around the falling edge of the synchronous clock (Figure 14-9). The transmission can also be started by first loading TXREG and then setting TXEN. This is advantageous when slow baud rates are selected, since BRG is kept in RESET when the TXEN, CREN, and SREN bits are clear. Setting the TXEN bit will start the BRG, creating a shift clock immediately. Normally when transmission is first started, the TSR is empty, so a transfer to TXREG will result in an immediate transfer to the TSR, resulting in an empty TXREG. Back-to-back transfers are possible.

Clearing TXEN during a transmission will cause the transmission to be aborted and will reset the transmitter. The RX/DT and TX/CK pins will revert to hi-impedance. If either CREN or SREN are set during a transmission, the transmission is aborted and the RX/DT pin reverts to a hi-impedance state (for a reception). The TX/CK pin will remain an output if the CSRC bit is set (internal clock). The transmitter logic is not reset, although it is disconnected from the pins. In order to reset the transmitter, the user has to clear the TXEN bit. If the SREN bit is set (to interrupt an ongoing transmission and receive a single word), then after the single word is received, SREN will be cleared and the serial port will revert back to transmitting, since the TXEN bit is still set. The DT line will immediately switch from hi-impedance Receive mode to transmit and start driving. To avoid this, TXEN should be cleared.

In order to select 9-bit transmission, the TX9 (TXSTA<6>) bit should be set and the ninth bit should be written to TX9D (TXSTA<0>). The ninth bit must be written before writing the 8-bit data to TXREG. This is because a data write to TXREG can result in an immediate transfer of the data to the TSR (if the TSR is empty). If the TSR was empty and TXREG was written before writing the “new” TX9D, the “present” value of TX9D is loaded.

Steps to follow when setting up a Synchronous Master Transmission:

1. Initialize the SPBRG register for the appropriate baud rate (see Baud Rate Generator Section for details).
2. Enable the synchronous master serial port by setting the SYNC, SPEN, and CSRC bits.
3. Ensure that the CREN and SREN bits are clear (these bits override transmission when set).
4. If interrupts are desired, then set the TXIE bit (the GLINTD bit must be clear and the PEIE bit must be set).
5. If 9-bit transmission is desired, then set the TX9 bit.
6. If 9-bit transmission is selected, the ninth bit should be loaded in TX9D.
7. Start transmission by loading data to the TXREG register.
8. Enable the transmission by setting TXEN.

Writing the transmit data to the TXREG, then enabling the transmit (setting TXEN), allows transmission to start sooner than doing these two events in the reverse order.

Note: To terminate a transmission, either clear the SPEN bit, or the TXEN bit. This will reset the transmit logic, so that it will be in the proper state when transmit is re-enabled.

PIC17C7XX

TABLE 14-8: REGISTERS ASSOCIATED WITH SYNCHRONOUS MASTER TRANSMISSION

Address	Name	Bit 7	Bit 6	Bit 5	Bit 4	Bit 3	Bit 2	Bit 1	Bit 0	Value on POR, BOR	MCLR, WDT
16h, Bank 1	PIR1	RBIF	TMR3IF	TMR2IF	TMR1IF	CA2IF	CA1IF	TX1IF	RC1IF	x000 0010	u000 0010
17h, Bank 1	PIE1	RBIE	TMR3IE	TMR2IE	TMR1IE	CA2IE	CA1IE	TX1IE	RC1IE	0000 0000	0000 0000
13h, Bank 0	RCSTA1	SPEN	RX9	SREN	CREN	—	FERR	OERR	RX9D	0000 -00x	0000 -00u
16h, Bank 0	TXREG1	TX7	TX6	TX5	TX4	TX3	TX2	TX1	TX0	xxxx xxxx	uuuu uuuu
15h, Bank 0	TXSTA1	CSRC	TX9	TXEN	SYNC	—	—	TRMT	TX9D	0000 --1x	0000 --1u
17h, Bank 0	SPBRG1	Baud Rate Generator Register								0000 0000	0000 0000
10h, Bank 4	PIR2	SSPIF	BCLIF	ADIF	—	CA4IF	CA3IF	TX2IF	RC2IF	000- 0010	000- 0010
11h, Bank 4	PIE2	SSPIE	BCLIE	ADIE	—	CA4IE	CA3IE	TX2IE	RC2IE	000- 0000	000- 0000
13h, Bank 4	RCSTA2	SPEN	RX9	SREN	CREN	—	FERR	OERR	RX9D	0000 -00x	0000 -00u
16h, Bank 4	TXREG2	TX7	TX6	TX5	TX4	TX3	TX2	TX1	TX0	xxxx xxxx	uuuu uuuu
15h, Bank 4	TXSTA2	CSRC	TX9	TXEN	SYNC	—	—	TRMT	TX9D	0000 --1x	0000 --1u
17h, Bank 4	SPBRG2	Baud Rate Generator Register								0000 0000	0000 0000

Legend: x = unknown, u = unchanged, - = unimplemented, read as a '0'. Shaded cells are not used for synchronous master transmission.

FIGURE 14-8: SYNCHRONOUS TRANSMISSION

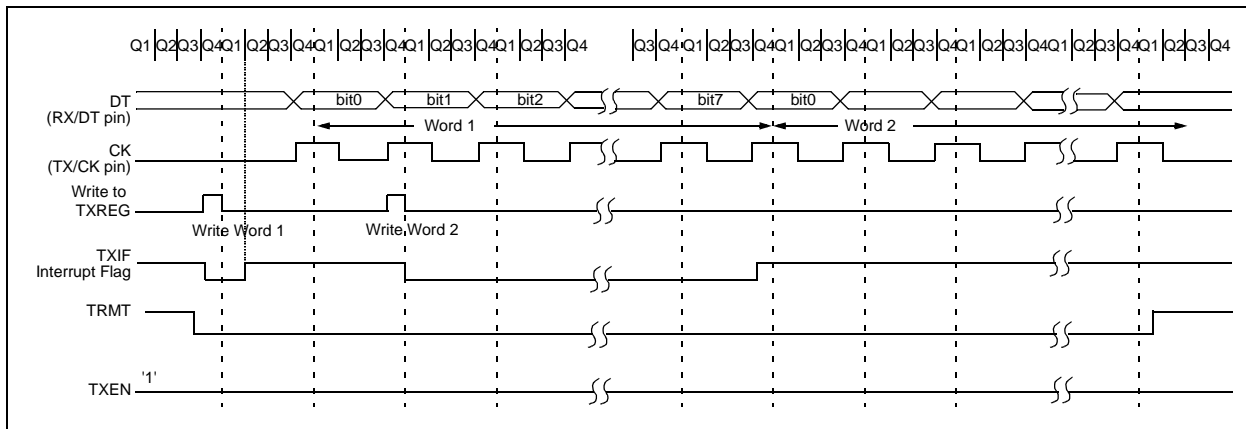
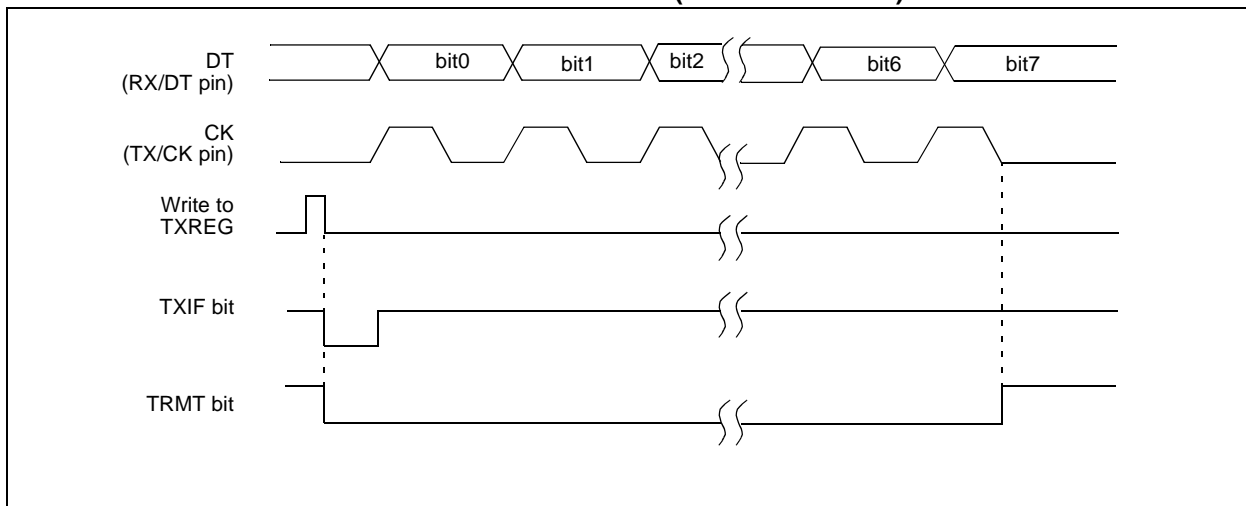

FIGURE 14-9: SYNCHRONOUS TRANSMISSION (THROUGH TXEN)



14.3.2 USART SYNCHRONOUS MASTER RECEPTION

Once Synchronous mode is selected, reception is enabled by setting either the SREN (RCSTA<5>) bit or the CREN (RCSTA<4>) bit. Data is sampled on the RX/DT pin on the falling edge of the clock. If SREN is set, then only a single word is received. If CREN is set, the reception is continuous until CREN is reset. If both bits are set, then CREN takes precedence. After clocking the last bit, the received data in the Receive Shift Register (RSR) is transferred to RCREG (if it is empty). If the transfer is complete, the interrupt bit RCIF is set. The actual interrupt can be enabled/disabled by setting/clearing the RCIE bit. RCIF is a read only bit which is reset by the hardware. In this case, it is reset when RCREG has been read and is empty. RCREG is a double buffered register; i.e., it is a two deep FIFO. It is possible for two bytes of data to be received and transferred to the RCREG FIFO and a third byte to begin shifting into the RSR. On the clocking of the last bit of the third byte, if RCREG is still full, then the overrun error bit OERR (RCSTA<1>) is set. The word in the RSR will be lost. RCREG can be read twice to retrieve the two bytes in the FIFO. The OERR bit has to be cleared in software. This is done by clearing the CREN bit. If OERR is set, transfers from RSR to RCREG are inhibited, so it is essential to clear the OERR bit if it is set. The 9th receive bit is buffered the same way as the receive data. Reading the RCREG register will allow the RX9D and FERR bits to be loaded with values for the next received data; therefore, it is essential for the user to read the RCSTA register before reading RCREG in order not to lose the old FERR and RX9D information.

Steps to follow when setting up a Synchronous Master Reception:

1. Initialize the SPBRG register for the appropriate baud rate. See Section 14.1 for details.
2. Enable the synchronous master serial port by setting bits SYNC, SPEN, and CSRC.
3. If interrupts are desired, then set the RCIE bit.
4. If 9-bit reception is desired, then set the RX9 bit.
5. If a single reception is required, set bit SREN. For continuous reception set bit CREN.
6. The RCIF bit will be set when reception is complete and an interrupt will be generated if the RCIE bit was set.
7. Read RCSTA to get the ninth bit (if enabled) and determine if any error occurred during reception.
8. Read the 8-bit received data by reading RCREG.
9. If any error occurred, clear the error by clearing CREN.

Note: To terminate a reception, either clear the SREN and CREN bits, or the SPEN bit. This will reset the receive logic so that it will be in the proper state when receive is re-enabled.

FIGURE 14-10: SYNCHRONOUS RECEPTION (MASTER MODE, SREN)

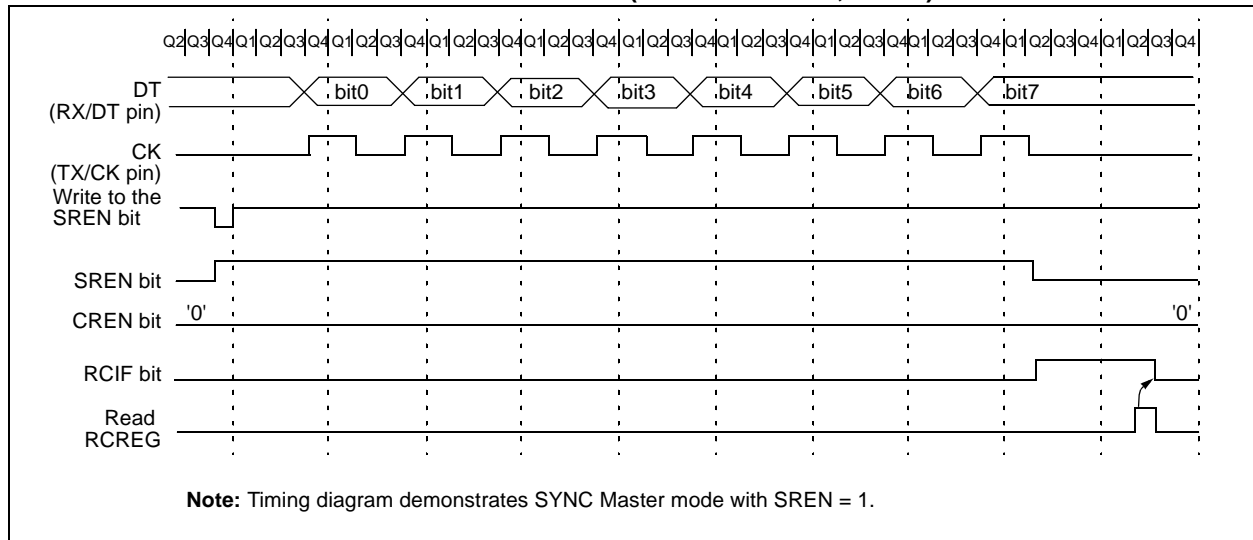

PIC17C7XX

TABLE 14-9: REGISTERS ASSOCIATED WITH SYNCHRONOUS MASTER RECEPTION

Address	Name	Bit 7	Bit 6	Bit 5	Bit 4	Bit 3	Bit 2	Bit 1	Bit 0	Value on POR, BOR	MCLR, WDT
16h, Bank 1	PIR1	RBIF	TMR3IF	TMR2IF	TMR1IF	CA2IF	CA1IF	TX1IF	RC1IF	x000 0010	u000 0010
17h, Bank 1	PIE1	RBIE	TMR3IE	TMR2IE	TMR1IE	CA2IE	CA1IE	TX1IE	RC1IE	0000 0000	0000 0000
13h, Bank 0	RCSTA1	SPEN	RX9	SREN	CREN	—	FERR	OERR	RX9D	0000 -00x	0000 -00u
14h, Bank 0	RCREG1	RX7	RX6	RX5	RX4	RX3	RX2	RX1	RX0	xxxx xxxx	uuuu uuuu
15h, Bank 0	TXSTA1	CSRC	TX9	TXEN	SYNC	—	—	TRMT	TX9D	0000 --1x	0000 --1u
17h, Bank 0	SPBRG1	Baud Rate Generator Register								0000 0000	0000 0000
10h, Bank 4	PIR2	SSPIF	BCLIF	ADIF	—	CA4IF	CA3IF	TX2IF	RC2IF	000- 0010	000- 0010
11h, Bank 4	PIE2	SSPIE	BCLIE	ADIE	—	CA4IE	CA3IE	TX2IE	RC2IE	000- 0000	000- 0000
13h, Bank 4	RCSTA2	SPEN	RX9	SREN	CREN	—	FERR	OERR	RX9D	0000 -00x	0000 -00u
14h, Bank 4	RCREG2	RX7	RX6	RX5	RX4	RX3	RX2	RX1	RX0	xxxx xxxx	uuuu uuuu
15h, Bank 4	TXSTA2	CSRC	TX9	TXEN	SYNC	—	—	TRMT	TX9D	0000 --1x	0000 --1u
17h, Bank 4	SPBRG2	Baud Rate Generator Register								0000 0000	0000 0000

Legend: x = unknown, u = unchanged, - = unimplemented, read as a '0'. Shaded cells are not used for synchronous master reception.

14.4 USART Synchronous Slave Mode

The Synchronous Slave mode differs from the Master mode, in the fact that the shift clock is supplied externally at the TX/CK pin (instead of being supplied internally in the Master mode). This allows the device to transfer or receive data in the SLEEP mode. The Slave mode is entered by clearing the CSRC (TXSTA<7>) bit.

14.4.1 USART SYNCHRONOUS SLAVE TRANSMIT

The operation of the SYNC Master and Slave modes are identical except in the case of the SLEEP mode.

If two words are written to TXREG and then the SLEEP instruction executes, the following will occur. The first word will immediately transfer to the TSR and will transmit as the shift clock is supplied. The second word will remain in TXREG. TXIF will not be set. When the first word has been shifted out of TSR, TXREG will transfer the second word to the TSR and the TXIF flag will now be set. If TXIE is enabled, the interrupt will wake the chip from SLEEP and if the global interrupt is enabled, then the program will branch to the interrupt vector (0020h).

Steps to follow when setting up a Synchronous Slave Transmission:

1. Enable the synchronous slave serial port by setting the SYNC and SPEN bits and clearing the CSRC bit.
2. Clear the CREN bit.
3. If interrupts are desired, then set the TXIE bit.
4. If 9-bit transmission is desired, then set the TX9 bit.
5. If 9-bit transmission is selected, the ninth bit should be loaded in TX9D.
6. Start transmission by loading data to TXREG.
7. Enable the transmission by setting TXEN.

Writing the transmit data to the TXREG, then enabling the transmit (setting TXEN), allows transmission to start sooner than doing these two events in the reverse order.

Note: To terminate a transmission, either clear the SPEN bit, or the TXEN bit. This will reset the transmit logic, so that it will be in the proper state when transmit is re-enabled.

14.4.2 USART SYNCHRONOUS SLAVE RECEPTION

Operation of the Synchronous Master and Slave modes are identical except in the case of the SLEEP mode. Also, SREN is a "don't care" in Slave mode.

If receive is enabled (CREN) prior to the SLEEP instruction, then a word may be received during SLEEP. On completely receiving the word, the RSR will transfer the data to RCREG (setting RCIF) and if the RCIE bit is set, the interrupt generated will wake the chip from SLEEP. If the global interrupt is enabled, the program will branch to the interrupt vector (0020h).

Steps to follow when setting up a Synchronous Slave Reception:

1. Enable the synchronous master serial port by setting the SYNC and SPEN bits and clearing the CSRC bit.
2. If interrupts are desired, then set the RCIE bit.
3. If 9-bit reception is desired, then set the RX9 bit.
4. To enable reception, set the CREN bit.
5. The RCIF bit will be set when reception is complete and an interrupt will be generated if the RCIE bit was set.
6. Read RCSTA to get the ninth bit (if enabled) and determine if any error occurred during reception.
7. Read the 8-bit received data by reading RCREG.
8. If any error occurred, clear the error by clearing the CREN bit.

Note: To abort reception, either clear the SPEN bit, or the CREN bit (when in Continuous Receive mode). This will reset the receive logic, so that it will be in the proper state when receive is re-enabled.

PIC17C7XX

TABLE 14-10: REGISTERS ASSOCIATED WITH SYNCHRONOUS SLAVE TRANSMISSION

Address	Name	Bit 7	Bit 6	Bit 5	Bit 4	Bit 3	Bit 2	Bit 1	Bit 0	Value on POR, BOR	MCLR, WDT
16h, Bank 1	PIR1	RBIF	TMR3IF	TMR2IF	TMR1IF	CA2IF	CA1IF	TX1IF	RC1IF	x000 0010	u000 0010
17h, Bank 1	PIE1	RBIE	TMR3IE	TMR2IE	TMR1IE	CA2IE	CA1IE	TX1IE	RC1IE	0000 0000	0000 0000
13h, Bank 0	RCSTA1	SPEN	RX9	SREN	CREN	—	FERR	OERR	RX9D	0000 -00x	0000 -00u
15h, Bank 0	TXSTA1	CSRC	TX9	TXEN	SYNC	—	—	TRMT	TX9D	0000 --1x	0000 --1u
16h, Bank 0	TXREG1	TX7	TX6	TX5	TX4	TX3	TX2	TX1	TX0	xxxx xxxx	uuuu uuuu
17h, Bank 0	SPBRG1	Baud Rate Generator Register								0000 0000	0000 0000
10h, Bank 4	PIR2	SSPIF	BCLIF	ADIF	—	CA4IF	CA3IF	TX2IF	RC2IF	000- 0010	000- 0010
11h, Bank 4	PIE2	SSPIE	BCLIE	ADIE	—	CA4IE	CA3IE	TX2IE	RC2IE	000- 0000	000- 0000
13h, Bank 4	RCSTA2	SPEN	RX9	SREN	CREN	—	FERR	OERR	RX9D	0000 -00x	0000 -00u
16h, Bank 4	TXREG2	TX7	TX6	TX5	TX4	TX3	TX2	TX1	TX0	xxxx xxxx	uuuu uuuu
15h, Bank 4	TXSTA2	CSRC	TX9	TXEN	SYNC	—	—	TRMT	TX9D	0000 --1x	0000 --1u
17h, Bank 4	SPBRG2	Baud Rate Generator Register								0000 0000	0000 0000

Legend: x = unknown, u = unchanged, - = unimplemented, read as a '0'. Shaded cells are not used for synchronous slave transmission.

TABLE 14-11: REGISTERS ASSOCIATED WITH SYNCHRONOUS SLAVE RECEPTION

Address	Name	Bit 7	Bit 6	Bit 5	Bit 4	Bit 3	Bit 2	Bit 1	Bit 0	Value on POR, BOR	MCLR, WDT
16h, Bank1	PIR1	RBIF	TMR3IF	TMR2IF	TMR1IF	CA2IF	CA1IF	TX1IF	RC1IF	x000 0010	u000 0010
17h, Bank1	PIE1	RBIE	TMR3IE	TMR2IE	TMR1IE	CA2IE	CA1IE	TX1IE	RC1IE	0000 0000	0000 0000
13h, Bank0	RCSTA1	SPEN	RX9	SREN	CREN	—	FERR	OERR	RX9D	0000 -00x	0000 -00u
14h, Bank0	RCREG1	RX7	RX6	RX5	RX4	RX3	RX2	RX1	RX0	xxxx xxxx	uuuu uuuu
15h, Bank 0	TXSTA1	CSRC	TX9	TXEN	SYNC	—	—	TRMT	TX9D	0000 --1x	0000 --1u
17h, Bank 0	SPBRG1	Baud Rate Generator Register								0000 0000	0000 0000
10h, Bank 4	PIR2	SSPIF	BCLIF	ADIF	—	CA4IF	CA3IF	TX2IF	RC2IF	000- 0010	000- 0010
11h, Bank 4	PIE2	SSPIE	BCLIE	ADIE	—	CA4IE	CA3IE	TX2IE	RC2IE	000- 0000	000- 0000
13h, Bank 4	RCSTA2	SPEN	RX9	SREN	CREN	—	FERR	OERR	RX9D	0000 -00x	0000 -00u
14h, Bank 4	RCREG2	RX7	RX6	RX5	RX4	RX3	RX2	RX1	RX0	xxxx xxxx	uuuu uuuu
15h, Bank 4	TXSTA2	CSRC	TX9	TXEN	SYNC	—	—	TRMT	TX9D	0000 --1x	0000 --1u
17h, Bank 4	SPBRG2	Baud Rate Generator Register								0000 0000	0000 0000

Legend: x = unknown, u = unchanged, - = unimplemented, read as a '0'. Shaded cells are not used for synchronous slave reception.

15.0 MASTER SYNCHRONOUS SERIAL PORT (MSSP) MODULE

The Master Synchronous Serial Port (MSSP) module is a serial interface useful for communicating with other peripheral or microcontroller devices. These peripheral devices may be serial EEPROMs, shift registers, display drivers, A/D converters, etc. The MSSP module can operate in one of two modes:

- Serial Peripheral Interface (SPI)
- Inter-Integrated Circuit™ (I²C)

Figure 15-1 shows a block diagram for the SPI mode, while Figure 15-2 and Figure 15-3 show the block diagrams for the two different I²C modes of operation.

FIGURE 15-1: SPI MODE BLOCK DIAGRAM

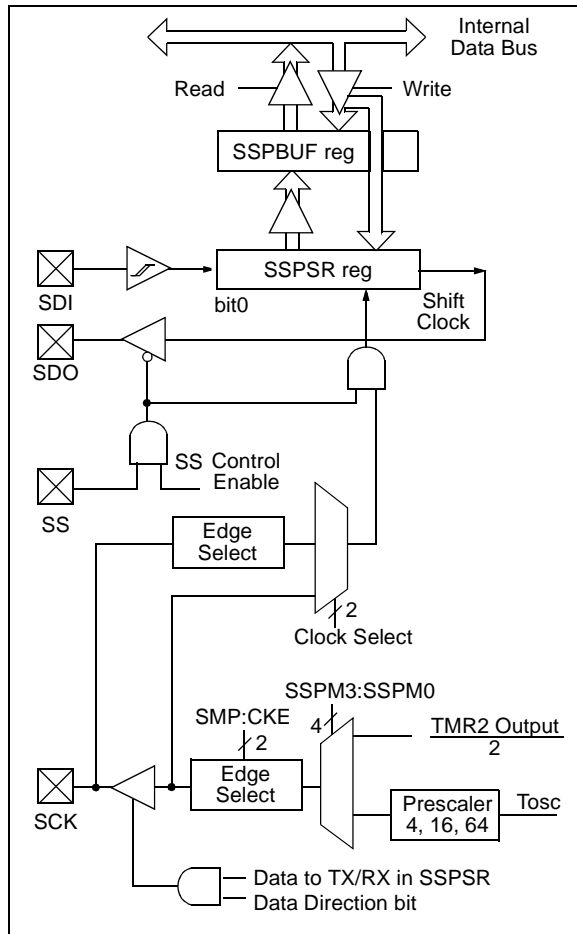

FIGURE 15-2: I²C SLAVE MODE BLOCK DIAGRAM

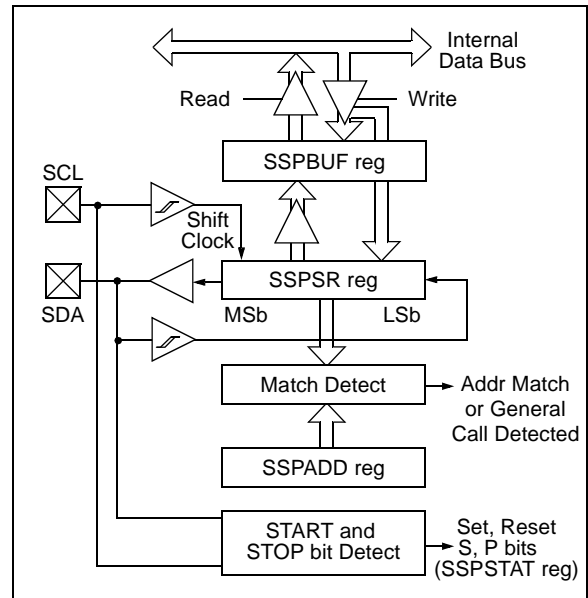
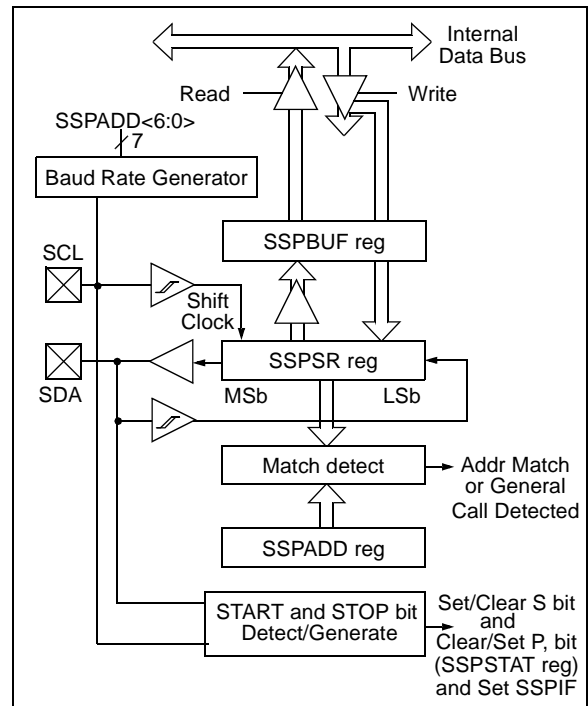

FIGURE 15-3: I²C MASTER MODE BLOCK DIAGRAM



PIC17C7XX

REGISTER 15-1: SSPSTAT: SYNC SERIAL PORT STATUS REGISTER (ADDRESS: 13h, BANK 6)

R/W-0	R/W-0	R-0	R-0	R-0	R-0	R-0	R-0
SMP	CKE	D/A	P	S	R/W	UA	BF
bit 7						bit 0	

- bit 7 **SMP:** Sample bit
SPI Master mode:
 1 = Input data sampled at end of data output time
 0 = Input data sampled at middle of data output time
SPI Slave mode:
 SMP must be cleared when SPI is used in Slave mode
In I²C Master or Slave mode:
 1 = Slew rate control disabled for Standard Speed mode (100 kHz and 1 MHz)
 0 = Slew rate control enabled for High Speed mode (400 kHz)
- bit 6 **CKE:** SPI Clock Edge Select (Figure 15-6, Figure 15-8 and Figure 15-9)
CKP = 0:
 1 = Data transmitted on rising edge of SCK
 0 = Data transmitted on falling edge of SCK
CKP = 1:
 1 = Data transmitted on falling edge of SCK
 0 = Data transmitted on rising edge of SCK
- bit 5 **D/A:** Data/Address bit (I²C mode only)
 1 = Indicates that the last byte received or transmitted was data
 0 = Indicates that the last byte received or transmitted was address
- bit 4 **P:** STOP bit
 (I²C mode only. This bit is cleared when the MSSP module is disabled, SSPEN is cleared.)
 1 = Indicates that a STOP bit has been detected last (this bit is '0' on RESET)
 0 = STOP bit was not detected last
- bit 3 **S:** START bit
 (I²C mode only. This bit is cleared when the MSSP module is disabled, SSPEN is cleared.)
 1 = Indicates that a START bit has been detected last (this bit is '0' on RESET)
 0 = START bit was not detected last
- bit 2 **R/W:** Read/Write bit Information (I²C mode only)
 This bit holds the R/W bit information following the last address match. This bit is only valid from the address match to the next START bit, STOP bit, or not ACK bit.
In I²C Slave mode:
 1 = Read
 0 = Write
In I²C Master mode:
 1 = Transmit is in progress
 0 = Transmit is not in progress
 Or'ing this bit with SEN, RSEN, PEN, RCEN, or ACKEN will indicate if the MSSP is in IDLE mode.
- bit 1 **UA:** Update Address (10-bit I²C mode only)
 1 = Indicates that the user needs to update the address in the SSPADD register
 0 = Address does not need to be updated
- bit 0 **BF:** Buffer Full Status bit
 Receive (SPI and I²C modes)
 1 = Receive complete, SSPBUF is full
 0 = Receive not complete, SSPBUF is empty
 Transmit (I²C mode only)
 1 = Data transmit in progress (does not include the ACK and STOP bits), SSPBUF is full
 0 = Data transmit complete (does not include the ACK and STOP bits), SSPBUF is empty

Legend:

R = Readable bit	W = Writable bit	U = Unimplemented bit, read as '0'
- n = Value at POR Reset	'1' = Bit is set	'0' = Bit is cleared x = Bit is unknown

REGISTER 15-2: SSPCON1: SYNC SERIAL PORT CONTROL REGISTER1 (ADDRESS 11h, BANK 6)

R/W-0	R/W-0	R/W-0	R/W-0	R/W-0	R/W-0	R/W-0	R/W-0
WCOL	SSPOV	SSPEN	CKP	SSPM3	SSPM2	SSPM1	SSPM0

bit 7

bit 0

bit 7 **WCOL:** Write Collision Detect bit

Master mode:

1 = A write to the SSPBUF register was attempted while the I²C conditions were not valid for a transmission to be started
0 = No collision

Slave mode:

1 = The SSPBUF register is written while it is still transmitting the previous word (must be cleared in software)
0 = No collision

bit 6 **SSPOV:** Receive Overflow Indicator bit

In SPI mode:

1 = A new byte is received while the SSPBUF register is still holding the previous data. In case of overflow, the data in SSPSR is lost. Overflow can only occur in Slave mode. In Slave mode, the user must read the SSPBUF, even if only transmitting data, to avoid setting overflow. In Master mode, the overflow bit is not set, since each new reception (and transmission) is initiated by writing to the SSPBUF register. (Must be cleared in software.)
0 = No overflow

In I²C mode:

1 = A byte is received while the SSPBUF register is still holding the previous byte. SSPOV is a "don't care" in Transmit mode. (Must be cleared in software.)
0 = No overflow

bit 5 **SSPEN:** Synchronous Serial Port Enable bit

In both modes, when enabled, these pins must be properly configured as input or output.

In SPI mode:

1 = Enables serial port and configures SCK, SDO, SDI and \overline{SS} as the source of the serial port pins
0 = Disables serial port and configures these pins as I/O port pins

In I²C mode:

1 = Enables the serial port and configures the SDA and SCL pins as the source of the serial port pins
0 = Disables serial port and configures these pins as I/O port pins

Note: In SPI mode, these pins must be properly configured as input or output.

bit 4 **CKP:** Clock Polarity Select bit

In SPI mode:

1 = Idle state for clock is a high level
0 = Idle state for clock is a low level

In I²C Slave mode:

SCK release control
1 = Enable clock
0 = Holds clock low (clock stretch). (Used to ensure data setup time.)

In I²C Master mode:

Unused in this mode

bit 3-0 **SSPM3:SSPM0:** Synchronous Serial Port Mode Select bits

0000 = SPI Master mode, clock = Fosc/4
0001 = SPI Master mode, clock = Fosc/16
0010 = SPI Master mode, clock = Fosc/64
0011 = SPI Master mode, clock = TMR2 output/2
0100 = SPI Slave mode, clock = SCK pin, \overline{SS} pin control enabled
0101 = SPI Slave mode, clock = SCK pin, \overline{SS} pin control disabled, \overline{SS} can be used as I/O pin
0110 = I²C Slave mode, 7-bit address
0111 = I²C Slave mode, 10-bit address
1000 = I²C Master mode, clock = Fosc / (4 * (SSPADD+1))
1xx1 = Reserved
1x1x = Reserved

Legend:

R = Readable bit	W = Writable bit	U = Unimplemented bit, read as '0'
- n = Value at POR Reset	'1' = Bit is set	'0' = Bit is cleared
		x = Bit is unknown

PIC17C7XX

REGISTER 15-3: SSPCON2: SYNC SERIAL PORT CONTROL REGISTER2 (ADDRESS 12h, BANK 6)

R/W-0	R/W-0	R/W-0	R/W-0	R/W-0	R/W-0	R/W-0	R/W-0
GCEN	ACKSTAT	ACKDT	ACKEN	RCEN	PEN	RSEN	SEN
bit 7							bit 0

- bit 7 **GCEN:** General Call Enable bit (in I²C Slave mode only)
 1 = Enable interrupt when a general call address (0000h) is received in the SSPSR
 0 = General call address disabled
- bit 6 **ACKSTAT:** Acknowledge Status bit (in I²C Master mode only)
In Master Transmit mode:
 1 = Acknowledge was not received from slave
 0 = Acknowledge was received from slave
- bit 5 **ACKDT:** Acknowledge Data bit (in I²C Master mode only)
In Master Receive mode:
 Value that will be transmitted when the user initiates an Acknowledge sequence at the end of a receive.
 1 = Not Acknowledge
 0 = Acknowledge
- bit 4 **ACKEN:** Acknowledge Sequence Enable bit (in I²C Master mode only)
In Master Receive mode:
 1 = Initiate Acknowledge sequence on SDA and SCL pins and transmit AKDT data bit.
 Automatically cleared by hardware.
 0 = Acknowledge sequence idle
Note: If the I²C module is not in the IDLE mode, this bit may not be set (no spooling) and the SSPBUF may not be written (or writes to the SSPBUF are disabled).
- bit 3 **RCEN:** Receive Enable bit (in I²C Master mode only)
 1 = Enables Receive mode for I²C
 0 = Receive idle
Note: If the I²C module is not in the IDLE mode, this bit may not be set (no spooling) and the SSPBUF may not be written (or writes to the SSPBUF are disabled).
- bit 2 **PEN:** STOP Condition Enable bit (in I²C Master mode only)
SCK Release Control:
 1 = Initiate STOP condition on SDA and SCL pins. Automatically cleared by hardware.
 0 = STOP condition idle
Note: If the I²C module is not in the IDLE mode, this bit may not be set (no spooling) and the SSPBUF may not be written (or writes to the SSPBUF are disabled).
- bit 1 **RSEN:** Repeated Start Condition Enabled bit (in I²C Master mode only)
 1 = Initiate Repeated Start condition on SDA and SCL pins. Automatically cleared by hardware.
 0 = Repeated Start condition idle
Note: If the I²C module is not in the IDLE mode, this bit may not be set (no spooling) and the SSPBUF may not be written (or writes to the SSPBUF are disabled).
- bit 0 **SEN:** START Condition Enabled bit (In I²C Master mode only)
 1 = Initiate START condition on SDA and SCL pins. Automatically cleared by hardware.
 0 = START condition idle.
Note: If the I²C module is not in the IDLE mode, this bit may not be set (no spooling) and the SSPBUF may not be written (or writes to the SSPBUF are disabled).

Legend:			
R = Readable bit	W = Writable bit	U = Unimplemented bit, read as '0'	
- n = Value at POR Reset	'1' = Bit is set	'0' = Bit is cleared	x = Bit is unknown

15.1 SPI Mode

The SPI mode allows 8-bits of data to be synchronously transmitted and received simultaneously. All four modes of SPI are supported. To accomplish communication, typically three pins are used:

- Serial Data Out (SDO)
- Serial Data In (SDI)
- Serial Clock (SCK)

Additionally, a fourth pin may be used when in a Slave mode of operation:

- Slave Select (\overline{SS})

15.1.1 OPERATION

When initializing the SPI, several options need to be specified. This is done by programming the appropriate control bits in the SSPCON1 register (SSPCON1<5:0>) and SSPSTAT<7:6>. These control bits allow the following to be specified:

- Master mode (SCK is the clock output)
- Slave mode (SCK is the clock input)
- Clock Polarity (Idle state of SCK)
- Data Input Sample Phase (middle or end of data output time)
- Clock Edge (output data on rising/falling edge of SCK)
- Clock Rate (Master mode only)
- Slave Select mode (Slave mode only)

Figure 15-4 shows the block diagram of the MSSP module when in SPI mode.

FIGURE 15-4: MSSP BLOCK DIAGRAM (SPI MODE)

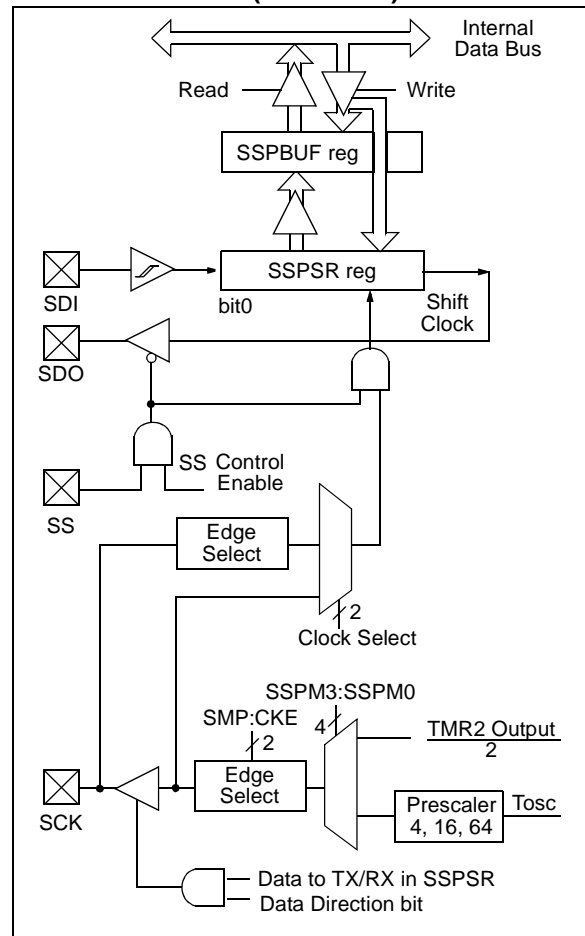

The MSSP consists of a transmit/receive Shift Register (SSPSR) and a Buffer register (SSPBUF). The SSPSR shifts the data in and out of the device, MSb first. The SSPBUF holds the data that was written to the SSPSR, until the received data is ready. Once the 8-bits of data have been received, that byte is moved to the SSPBUF register. Then the buffer full detect bit BF (SSPSTAT<0>) and the interrupt flag bit SSPIF (PIR2<7>) are set. This double buffering of the received data (SSPBUF) allows the next byte to start reception before reading the data that was just received. Any write to the SSPBUF register during transmission/reception of data will be ignored, and the write collision detect bit WCOL (SSPCON1<7>) will be set. User software must clear the WCOL bit so that it can be determined if the following write(s) to the SSPBUF register completed successfully.

PIC17C7XX

When the application software is expecting to receive valid data, the SSPBUF should be read before the next byte of data to transfer is written to the SSPBUF. Buffer full bit, BF (SSPSTAT<0>), indicates when SSPBUF has been loaded with the received data (transmission is complete). When the SSPBUF is read, bit BF is cleared. This data may be irrelevant if the SPI is only a transmitter. Generally the MSSP interrupt is used to determine when the transmission/reception has completed. The SSPBUF must be read and/or written. If the interrupt method is not going to be used, then software polling can be done to ensure that a write collision does not occur. Example 15-1 shows the loading of the SSPBUF (SSPSR) for data transmission.

EXAMPLE 15-1: LOADING THE SSPBUF (SSPSR) REGISTER

```
MOVLB 6           ; Bank 6
LOOP BTFSS SSPSTAT, BF ; Has data been
                    ; received
                    ; (transmit
                    ; complete)?

GOTO LOOP         ; No
MOVFP SSPBUF, RXDATA ; Save in user RAM
MOVFP TXDATA, SSPBUF ; New data to xmit
```

The SSPSR is not directly readable, or writable and can only be accessed by addressing the SSPBUF register. Additionally, the MSSP status register (SSPSTAT) indicates the various status conditions.

15.1.2 ENABLING SPI I/O

To enable the serial port, MSSP Enable bit, SSPEN (SSPCON1<5>), must be set. To reset or reconfigure SPI mode, clear bit SSPEN, re-initialize the SSPCON registers and then set bit SSPEN. This configures the SDI, SDO, SCK and SS pins as serial port pins. For the pins to behave as the serial port function, some must have their data direction bits (in the DDR register) appropriately programmed. That is:

- SDI is automatically controlled by the SPI module
- SDO must have DDRB<7> cleared
- SCK (Master mode) must have DDRB<6> cleared
- SCK (Slave mode) must have DDRB<6> set
- \overline{SS} must have PORTA<2> set

Any serial port function that is not desired may be overridden by programming the corresponding data direction (DDR) register to the opposite value.

15.1.3 TYPICAL CONNECTION

Figure 15-5 shows a typical connection between two microcontrollers. The master controller (Processor 1) initiates the data transfer by sending the SCK signal. Data is shifted out of both shift registers on their programmed clock edge and latched on the opposite edge of the clock. Both processors should be programmed to same Clock Polarity (CKP), then both controllers would send and receive data at the same time. Whether the data is meaningful (or dummy data) depends on the application software. This leads to three scenarios for data transmission:

- Master sends data — Slave sends dummy data
- Master sends data — Slave sends data
- Master sends dummy data — Slave sends data

FIGURE 15-5: SPI MASTER/SLAVE CONNECTION

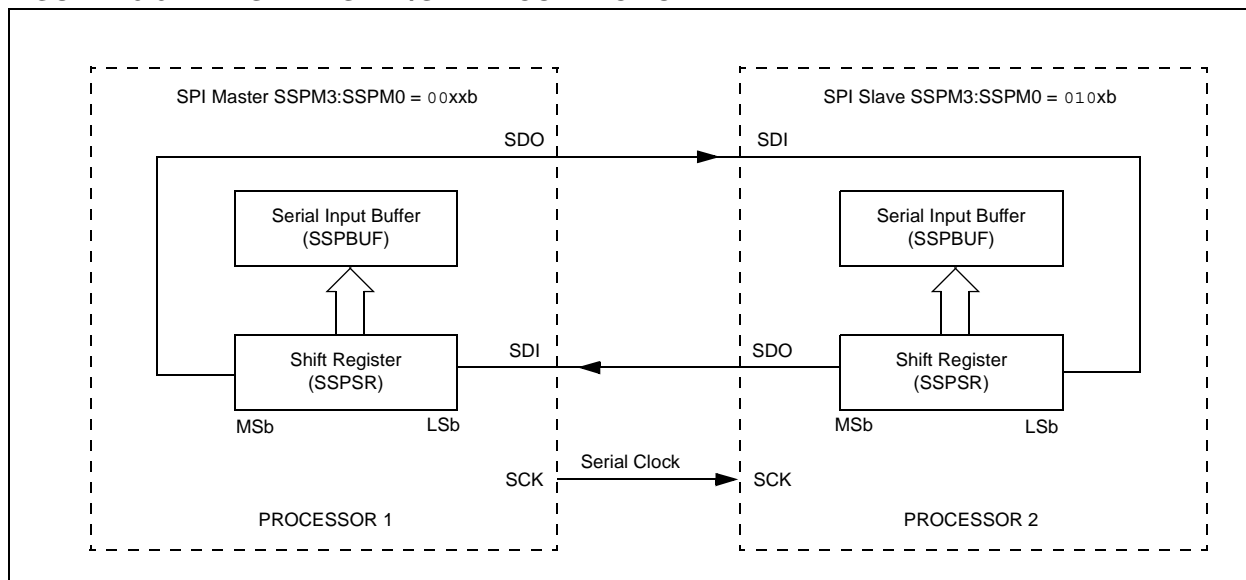

15.1.4 MASTER MODE

The master can initiate the data transfer at any time because it controls the SCK. The master determines when the slave (Processor 2, Figure 15-5) is to broadcast data by the software protocol.

In Master mode, the data is transmitted/received as soon as the SSPBUF register is written to. If the SPI is only going to receive, the SDO output could be disabled (programmed as an input). The SSPSR register will continue to shift in the signal present on the SDI pin at the programmed clock rate. As each byte is received, it will be loaded into the SSPBUF register as if a normal received byte (interrupts and status bits appropriately set). This could be useful in receiver applications as a "Line Activity Monitor" mode.

The clock polarity is selected by appropriately programming bit CKP (SSPCON1<4>). This then, would give waveforms for SPI communication as shown in

Figure 15-6, Figure 15-8 and Figure 15-9, where the MSb is transmitted first. In Master mode, the SPI clock rate (bit rate) is user programmable to be one of the following:

- $F_{OSC}/4$ (or T_{CY})
- $F_{OSC}/16$ (or $4 \cdot T_{CY}$)
- $F_{OSC}/64$ (or $16 \cdot T_{CY}$)
- $\text{Timer2 output}/2$

This allows a maximum bit clock frequency (at 33 MHz) of 8.25 MHz.

Figure 15-6 shows the waveforms for Master mode. When $CKE = 1$, the SDO data is valid before there is a clock edge on SCK. The change of the input sample is shown based on the state of the SMP bit. The time when the SSPBUF is loaded with the received data is shown.

FIGURE 15-6: SPI MODE WAVEFORM (MASTER MODE)

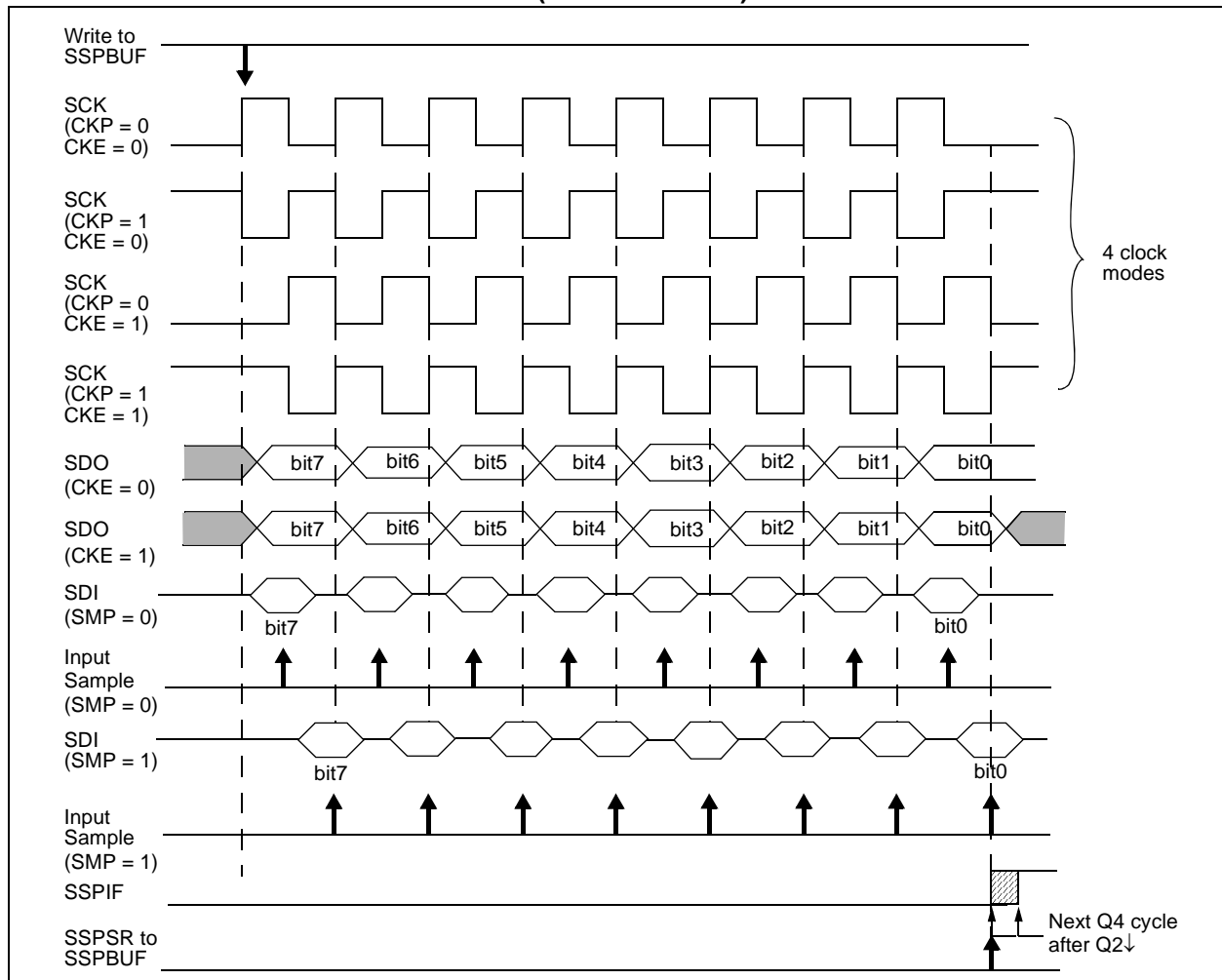

PIC17C7XX

15.1.5 SLAVE MODE

In Slave mode, the data is transmitted and received as the external clock pulses appear on SCK. When the last bit is latched, the interrupt flag bit SSPIF (PIR2<7>) is set.

While in Slave mode, the external clock is supplied by the external clock source on the SCK pin. This external clock must meet the minimum high and low times as specified in the electrical specifications.

While in SLEEP mode, the slave can transmit/receive data. When a byte is received, the device will wake-up from SLEEP.

15.1.6 SLAVE SELECT SYNCHRONIZATION

The \overline{SS} pin allows a Synchronous Slave mode. The SPI must be in Slave mode with \overline{SS} pin control enabled (SSPCON1<3:0> = 04h). The pin must not be driven low for the \overline{SS} pin to function as an input. The RA2 Data Latch must be high. When the \overline{SS} pin is low, transmission and reception are enabled and

the SDO pin is driven. When the \overline{SS} pin goes high, the SDO pin is no longer driven, even if in the middle of a transmitted byte and becomes a floating output. External pull-up/pull-down resistors may be desirable, depending on the application.

- Note 1:** When the SPI is in Slave mode with \overline{SS} pin control enabled (SSPCON<3:0> = 0100), the SPI module will reset if the \overline{SS} pin is set to VDD.
- 2:** If the SPI is used in Slave mode with \overline{CKE} = '1', then the \overline{SS} pin control must be enabled.

When the SPI module resets, the bit counter is forced to 0. This can be done by either forcing the \overline{SS} pin to a high level, or clearing the SSPEN bit.

To emulate two-wire communication, the SDO pin can be connected to the SDI pin. When the SPI needs to operate as a receiver, the SDO pin can be configured as an input. This disables transmissions from the SDO. The SDI can always be left as an input (SDI function), since it cannot create a bus conflict.

FIGURE 15-7: SLAVE SYNCHRONIZATION WAVEFORM

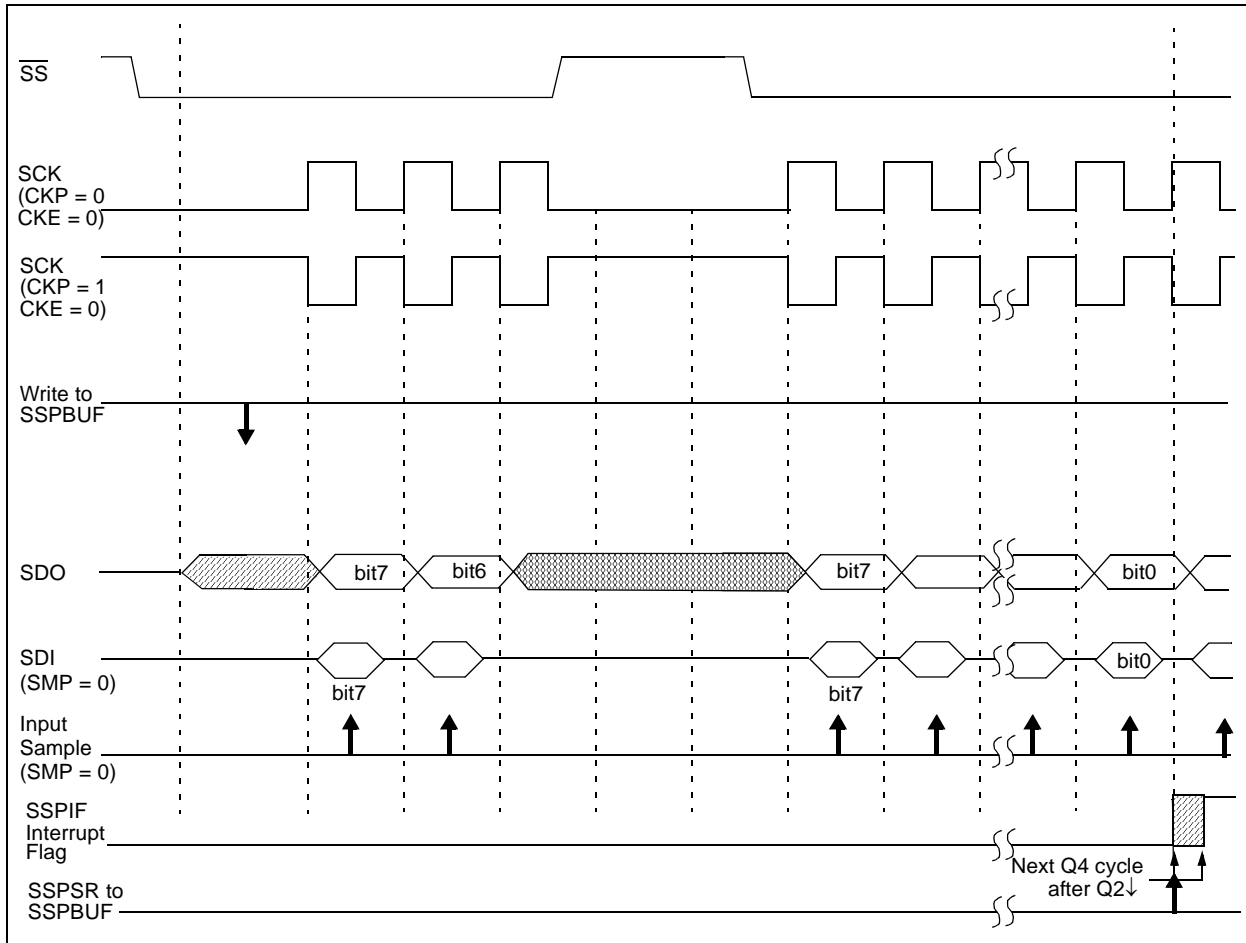

FIGURE 15-8: SPI MODE WAVEFORM (SLAVE MODE WITH CKE = 0)

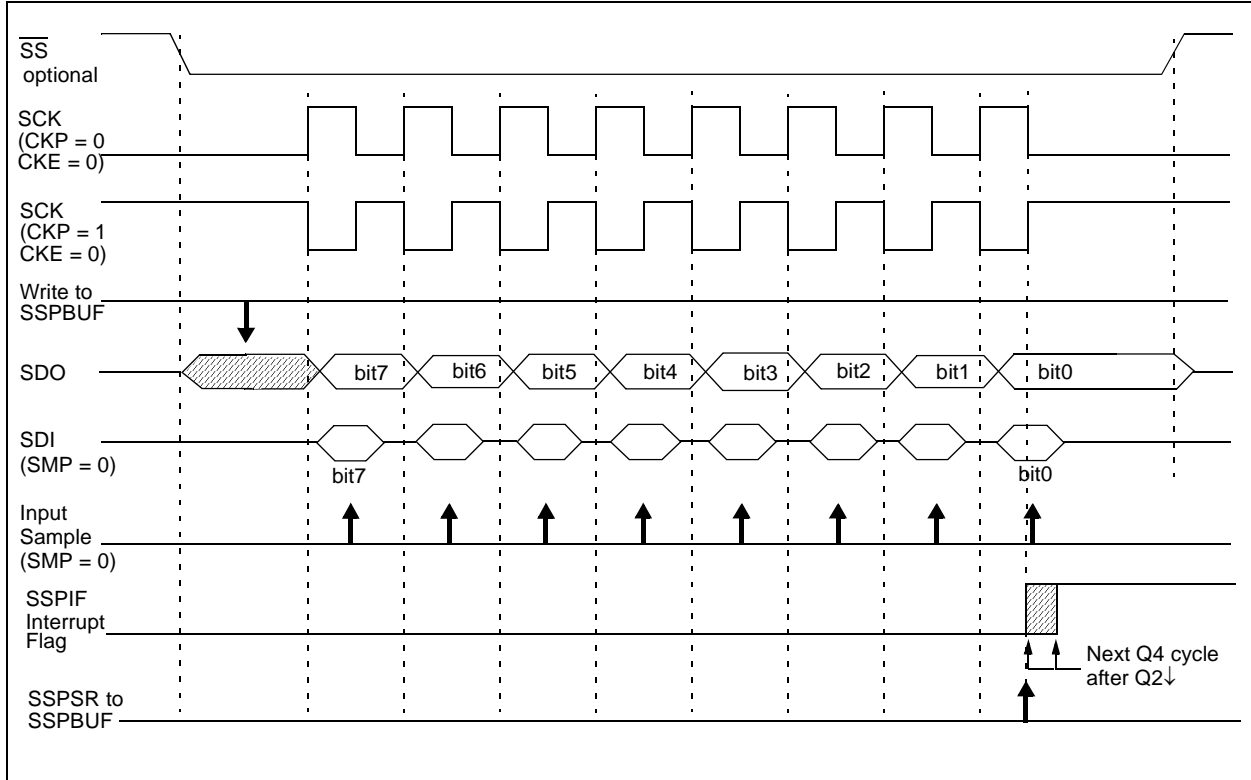
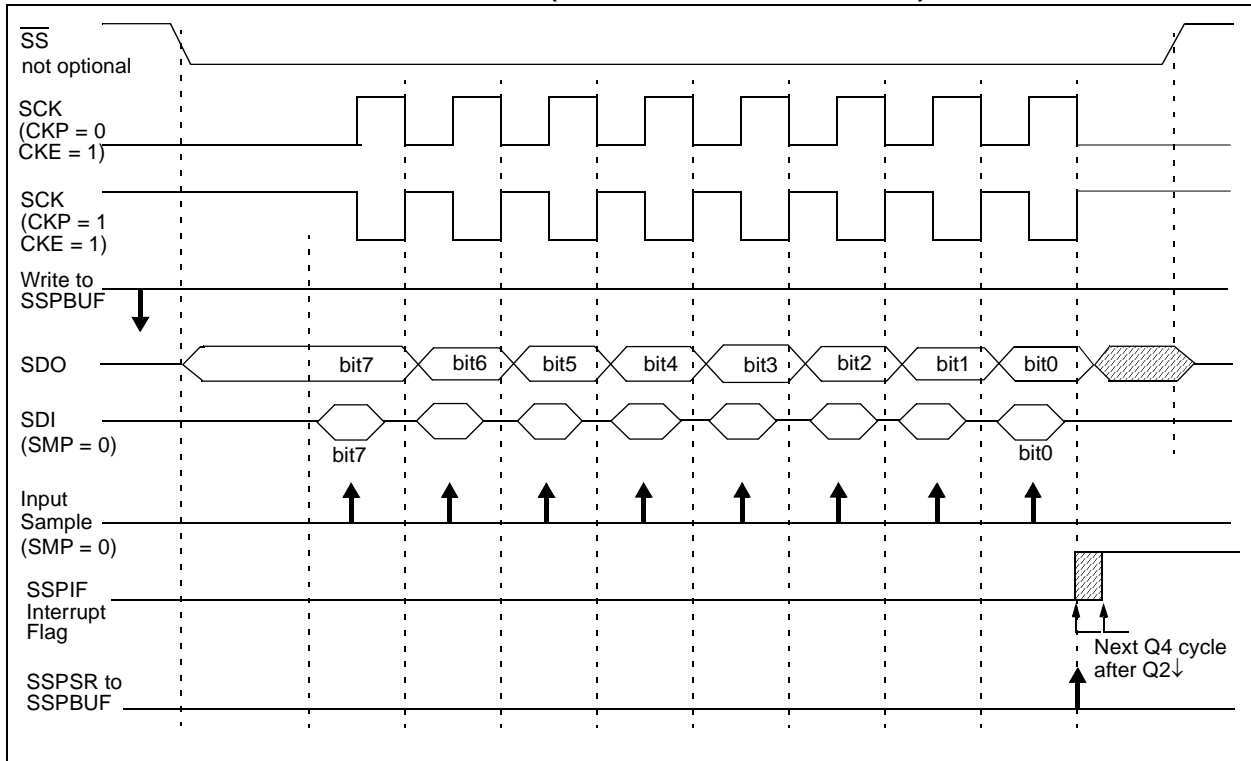

FIGURE 15-9: SPI MODE WAVEFORM (SLAVE MODE WITH CKE = 1)



PIC17C7XX

15.1.7 SLEEP OPERATION

In Master mode, all module clocks are halted, and the transmission/reception will remain in that state until the device wakes from SLEEP. After the device returns to normal mode, the module will continue to transmit/receive data.

In Slave mode, the SPI transmit/receive shift register operates asynchronously to the device. This allows the device to be placed in SLEEP mode and data to be

shifted into the SPI transmit/receive shift register. When all 8-bits have been received, the MSSP interrupt flag bit will be set and if enabled, will wake the device from SLEEP.

15.1.8 EFFECTS OF A RESET

A RESET disables the MSSP module and terminates the current transfer.

TABLE 15-1: REGISTERS ASSOCIATED WITH SPI OPERATION

Address	Name	Bit 7	Bit 6	Bit 5	Bit 4	Bit 3	Bit 2	Bit 1	Bit 0	POR, BOR	MCLR, WDT
07h, Unbanked	INTSTA	PEIF	T0CKIF	T0IF	INTF	PEIE	T0CKIE	T0IE	INTE	0000 0000	0000 0000
10h, Bank 4	PIR2	SSPIF	BCLIF	ADIF	—	CA4IF	CA3IF	TX2IF	RC2IF	000- 0010	000- 0010
11h, Bank 4	PIE2	SSPIE	BCLIE	ADIE	—	CA4IE	CA3IE	TX2IE	RC2IE	000- 0000	000- 0000
14h, Bank 6	SSPBUF	Synchronous Serial Port Receive Buffer/Transmit Register								xxxx xxxx	uuuu uuuu
11h, Bank 6	SSPCON1	WCOL	SSPOV	SSPEN	CKP	SSPM3	SSPM2	SSPM1	SSPM0	0000 0000	0000 0000
13h, Bank 6	SSPSTAT	SMP	CKE	D/ \bar{A}	P	S	R/ \bar{W}	UA	BF	0000 0000	0000 0000

Legend: x = unknown, u = unchanged, - = unimplemented, read as '0'. Shaded cells are not used by the SSP in SPI mode.

15.2 MSSP I²C Operation

The MSSP module in I²C mode fully implements all master and slave functions (including general call support) and provides interrupts on START and STOP bits in hardware to determine a free bus (multi-master function). The MSSP module implements the standard mode specifications as well as 7-bit and 10-bit addressing.

Refer to Application Note AN578, "Use of the SSP Module in the I²C Multi-Master Environment."

A "glitch" filter is on the SCL and SDA pins when the pin is an input. This filter operates in both the 100 kHz and 400 kHz modes. In the 100 kHz mode, when these pins are an output, there is a slew rate control of the pin that is independent of device frequency.

FIGURE 15-10: I²C SLAVE MODE BLOCK DIAGRAM

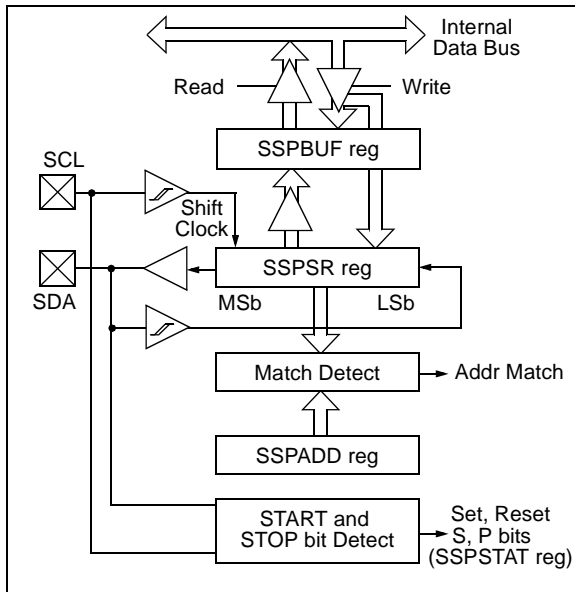
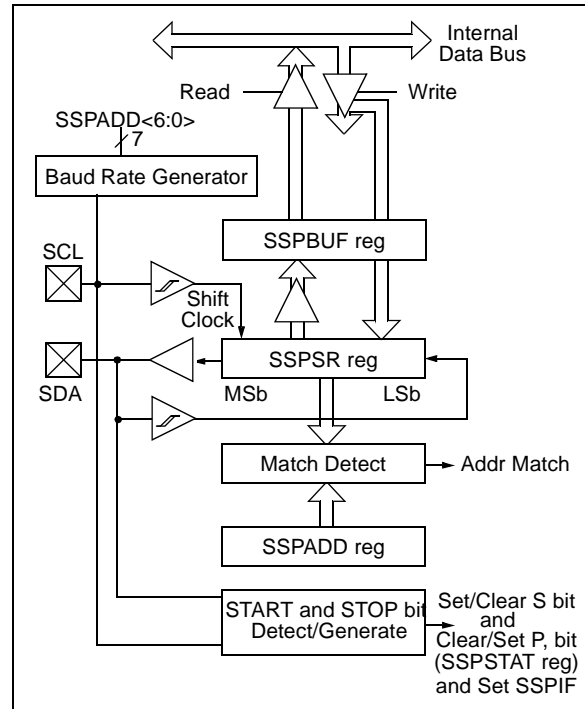

FIGURE 15-11: I²C MASTER MODE BLOCK DIAGRAM



Two pins are used for data transfer. These are the SCL pin, which is the clock and the SDA pin, which is the data. The SDA and SCL pins are automatically configured when the I²C mode is enabled. The SSP module functions are enabled by setting SSP Enable bit SSPEN (SSPCON1<5>).

The MSSP module has six registers for I²C operation. These are the:

- SSP Control Register1 (SSPCON1)
- SSP Control Register2 (SSPCON2)
- SSP Status Register (SSPSTAT)
- Serial Receive/Transmit Buffer (SSPBUF)
- SSP Shift Register (SSPSR) - Not directly accessible
- SSP Address Register (SSPADD)

The SSPCON1 register allows control of the I²C operation. Four mode selection bits (SSPCON1<3:0>) allow one of the following I²C modes to be selected:

- I²C Slave mode (7-bit address)
- I²C Slave mode (10-bit address)
- I²C Master mode, clock = OSC/4 (SSPADD +1)

Before selecting any I²C mode, the SCL and SDA pins must be programmed to inputs by setting the appropriate DDR bits. Selecting an I²C mode, by setting the SSPEN bit, enables the SCL and SDA pins to be used as the clock and data lines in I²C mode.

PIC17C7XX

The SSPSTAT register gives the status of the data transfer. This information includes detection of a START or STOP bit, specifies if the received byte was data or address if the next byte is the completion of 10-bit address and if this will be a read or write data transfer.

The SSPBUF is the register to which transfer data is written to or read from. The SSPSR register shifts the data in or out of the device. In receive operations, the SSPBUF and SSPSR create a doubled buffered receiver. This allows reception of the next byte to begin before reading the last byte of received data. When the complete byte is received, it is transferred to the SSPBUF register and flag bit SSPIF is set. If another complete byte is received before the SSPBUF register is read, a receiver overflow has occurred and bit SSPOV (SSPCON1<6>) is set and the byte in the SSPSR is lost.

The SSPADD register holds the slave address. In 10-bit mode, the user needs to write the high byte of the address (1111 0 A9 A8 0). Following the high byte address match, the low byte of the address needs to be loaded (A7:A0).

15.2.1 SLAVE MODE

In Slave mode, the SCL and SDA pins must be configured as inputs. The MSSP module will override the input state with the output data when required (slave-transmitter).

When an address is matched or the data transfer after an address match is received, the hardware automatically will generate the acknowledge (\overline{ACK}) pulse and then load the SSPBUF register with the received value currently in the SSPSR register.

There are certain conditions that will cause the MSSP module not to give this \overline{ACK} pulse. These are if either (or both):

- a) The buffer full bit BF (SSPSTAT<0>) was set before the transfer was received.
- b) The overflow bit SSPOV (SSPCON1<6>) was set before the transfer was received.

If the BF bit is set, the SSPSR register value is not loaded into the SSPBUF, but bit SSPIF and SSPOV are set. Table 15-2 shows what happens when a data transfer byte is received, given the status of bits BF and SSPOV. The shaded cells show the condition where user software did not properly clear the overflow condition. Flag bit BF is cleared by reading the SSPBUF register, while bit SSPOV is cleared through software.

The SCL clock input must have a minimum high and low time for proper operation. The high and low times of the I²C specification, as well as the requirement of the MSSP module, are shown in timing parameter #100 and parameter #101 of the Electrical Specifications.

15.2.1.1 Addressing

Once the MSSP module has been enabled, it waits for a START condition to occur. Following the START condition, the 8-bits are shifted into the SSPSR register. All incoming bits are sampled with the rising edge of the clock (SCL) line. The value of register SSPSR<7:1> is compared to the value of the SSPADD register. The address is compared on the falling edge of the eighth clock (SCL) pulse. If the addresses match and the BF and SSPOV bits are clear, the following events occur:

- The SSPSR register value is loaded into the SSPBUF register on the falling edge of the 8th SCL pulse.
- The buffer full bit, BF, is set on the falling edge of the 8th SCL pulse.
- An \overline{ACK} pulse is generated.
- SSP interrupt flag bit, SSPIF (PIR2<7>), is set (interrupt is generated if enabled) - on the falling edge of the 9th SCL pulse.

In 10-bit address mode, two address bytes need to be received by the slave. The five Most Significant bits (MSBs) of the first address byte specify if this is a 10-bit address. Bit R/W (SSPSTAT<2>) must specify a write so the slave device will receive the second address byte. For a 10-bit address, the first byte would equal '1111 0 A9 A8 0', where A9 and A8 are the two MSBs of the address. The sequence of events for a 10-bit address is as follows, with steps 7- 9 for slave-transmitter:

- Receive first (high) byte of Address (bits SSPIF, BF and bit UA (SSPSTAT<1>) are set).
- Update the SSPADD register with second (low) byte of Address (clears bit UA and releases the SCL line).
- Read the SSPBUF register (clears bit BF) and clear flag bit SSPIF.
- Receive second (low) byte of Address (bits SSPIF, BF and UA are set).

- Update the SSPADD register with the first (high) byte of Address. This will clear bit UA and release the SCL line.
- Read the SSPBUF register (clears bit BF) and clear flag bit SSPIF.
- Receive Repeated Start condition.
- Receive first (high) byte of Address (bits SSPIF and BF are set).
- Read the SSPBUF register (clears bit BF) and clear flag bit SSPIF.

Note: Following the Repeated Start condition (step 7) in 10-bit mode, the user only needs to match the first 7-bit address. The user does not update the SSPADD for the second half of the address.

15.2.1.2 Slave Reception

When the R/W bit of the address byte is clear and an address match occurs, the R/W bit of the SSPSTAT register is cleared. The received address is loaded into the SSPBUF register.

When the address byte overflow condition exists, then no acknowledge (ACK) pulse is given. An overflow condition is defined as either bit BF (SSPSTAT<0>) is set, or bit SSPOV (SSPCON1<6>) is set.

An SSP interrupt is generated for each data transfer byte. Flag bit SSPIF (PIR2<7>) must be cleared in software. The SSPSTAT register is used to determine the status of the received byte.

Note: The SSPBUF will be loaded if the SSPOV bit is set and the BF flag is cleared. If a read of the SSPBUF was performed, but the user did not clear the state of the SSPOV bit before the next receive occurred, the \overline{ACK} is not sent and the SSPBUF is updated.

TABLE 15-2: DATA TRANSFER RECEIVED BYTE ACTIONS

Status Bits as Data Transfer is Received		SSPSR → SSPBUF	Generate \overline{ACK} Pulse	Set bit SSPIF (SSP Interrupt occurs if enabled)
BF	SSPOV			
0	0	Yes	Yes	Yes
1	0	No	No	Yes
1	1	No	No	Yes
0	1	Yes	No	Yes

Note 1: Shaded cells show the conditions where the user software did not properly clear the overflow condition.

PIC17C7XX

15.2.1.3 Slave Transmission

When the R/\overline{W} bit of the incoming address byte is set and an address match occurs, the R/\overline{W} bit of the SSPSTAT register is set. The received address is loaded into the SSPBUF register. The \overline{ACK} pulse will be sent on the ninth bit, and the SCL pin is held low. The transmit data must be loaded into the SSPBUF register, which also loads the SSPSR register. Then SCL pin should be enabled by setting bit CKP (SSPCON1<4>). The master must monitor the SCL pin prior to asserting another clock pulse. The slave devices may be holding off the master by stretching the clock. The eight data bits are shifted out on the falling edge of the SCL input. This ensures that the SDA signal is valid during the SCL high time (Figure 15-13).

An SSP interrupt is generated for each data transfer byte. The SSPIF flag bit must be cleared in software, and the SSPSTAT register is used to determine the status of the byte transfer. The SSPIF flag bit is set on the falling edge of the ninth clock pulse.

As a slave-transmitter, the \overline{ACK} pulse from the master-receiver is latched on the rising edge of the ninth SCL input pulse. If the SDA line was high (not \overline{ACK}), then the data transfer is complete. When the not \overline{ACK} is latched by the slave, the slave logic is reset and the slave then monitors for another occurrence of the START bit. If the SDA line was low (\overline{ACK}), the transmit data must be loaded into the SSPBUF register, which also loads the SSPSR register. Then, the SCL pin should be enabled by setting the CKP bit.

FIGURE 15-12: I²C WAVEFORMS FOR RECEPTION (7-BIT ADDRESS)

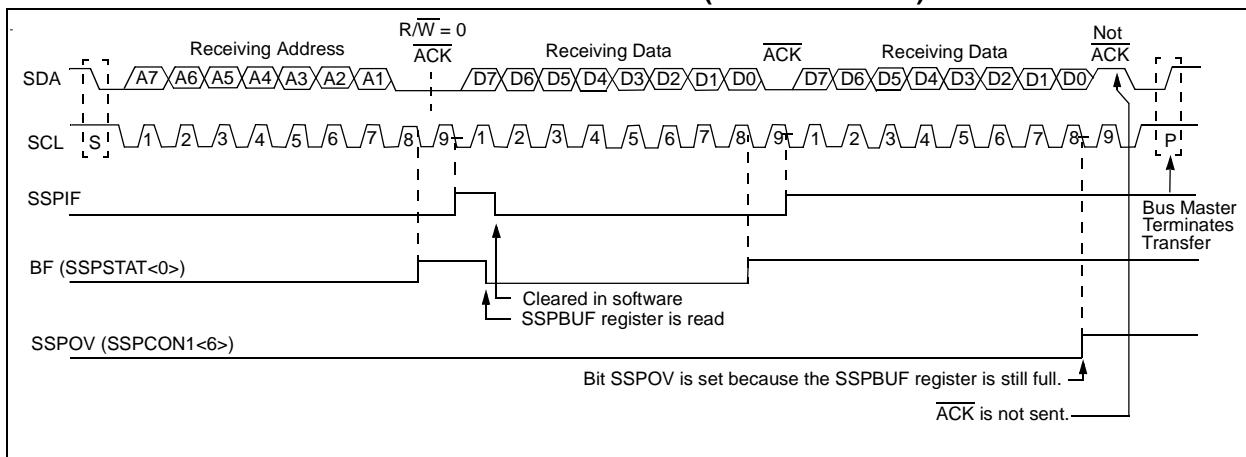

FIGURE 15-13: I²C WAVEFORMS FOR TRANSMISSION (7-BIT ADDRESS)

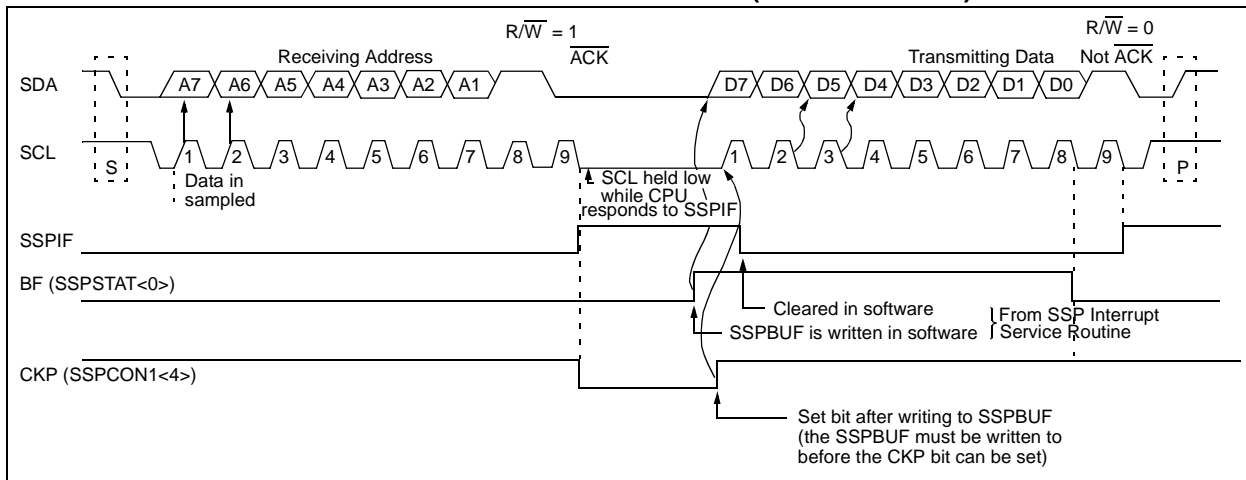
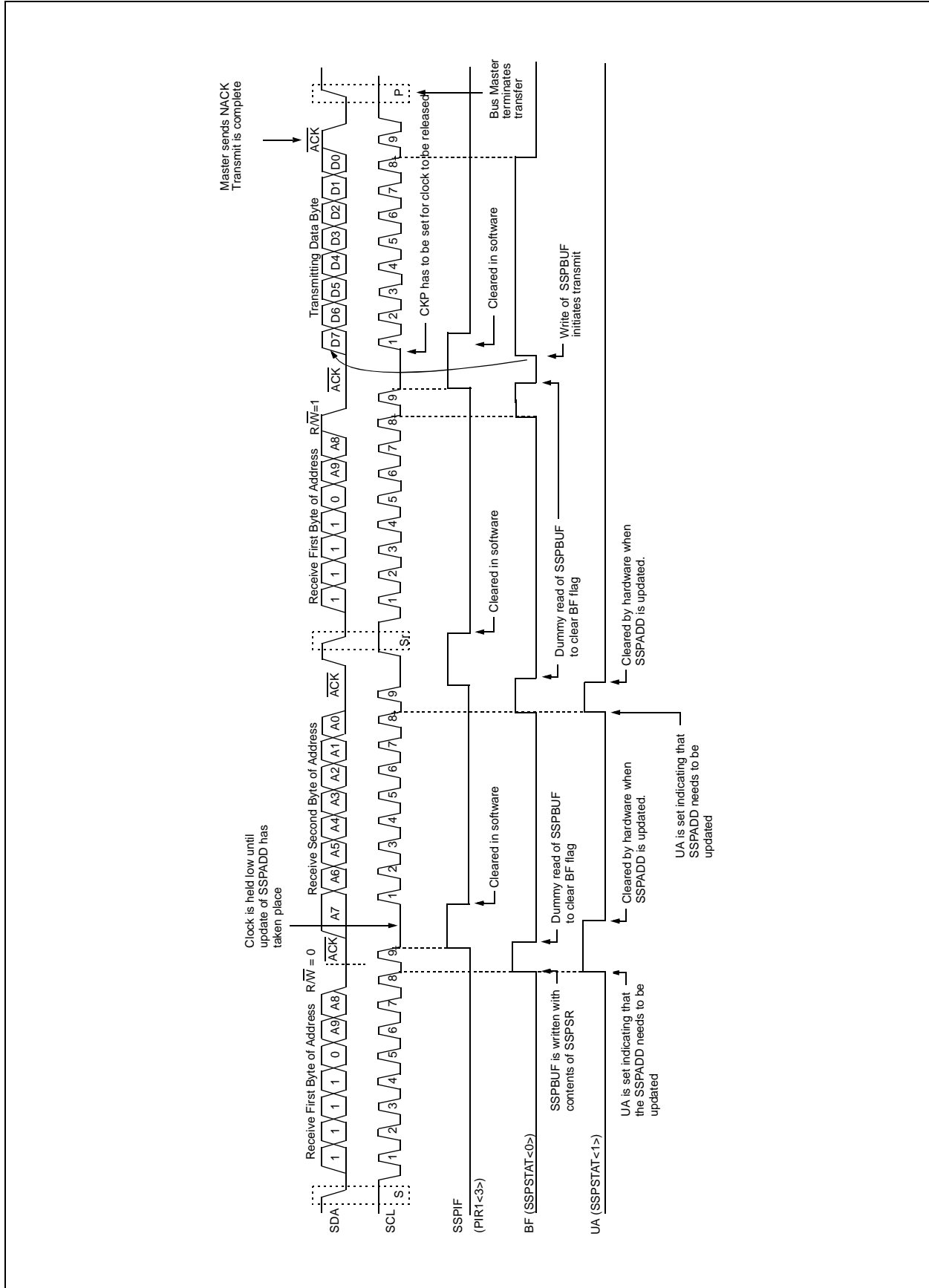
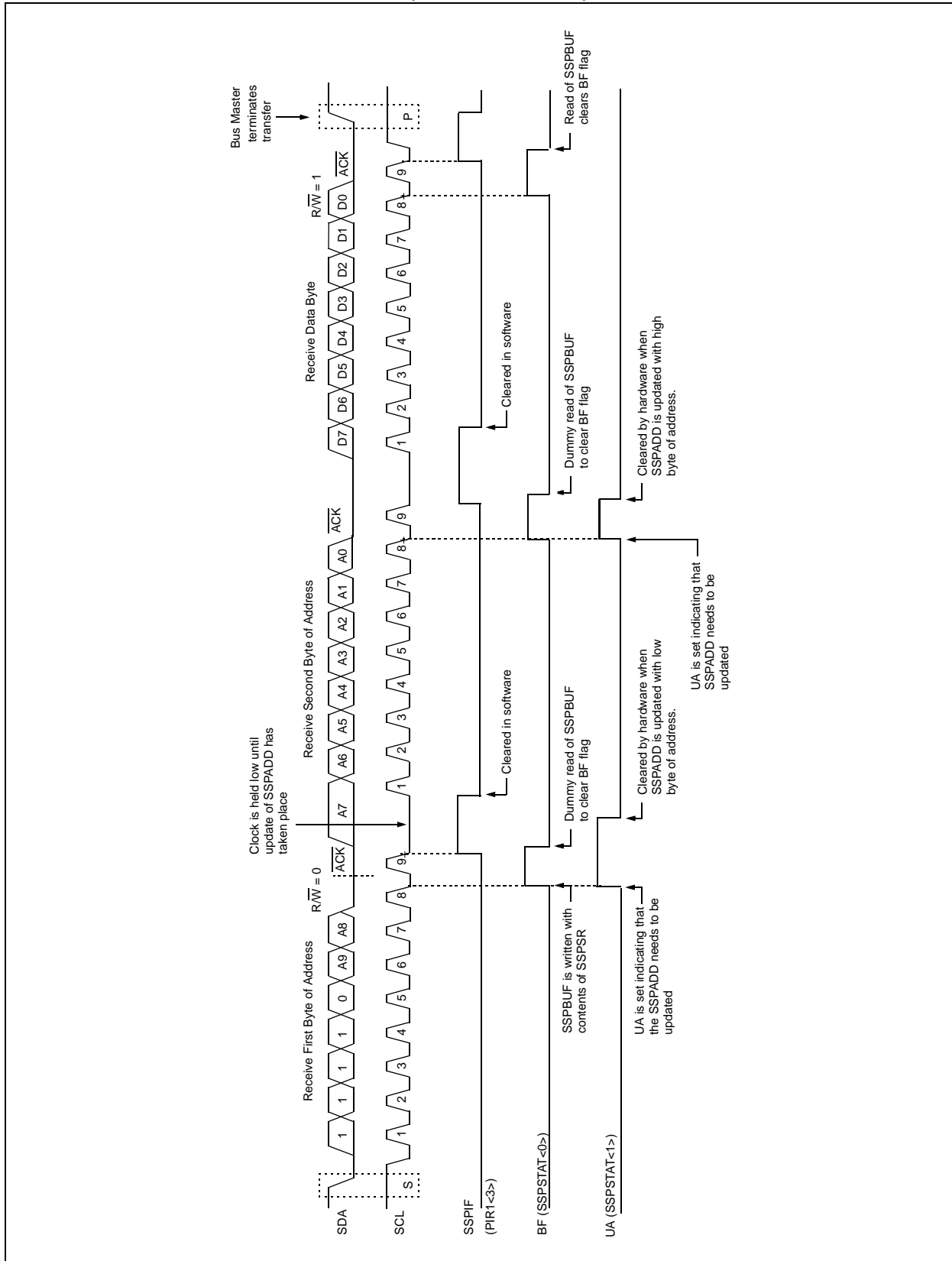

FIGURE 15-14: I²C SLAVE-TRANSMITTER (10-BIT ADDRESS)



PIC17C7XX

FIGURE 15-15: I²C SLAVE-RECEIVER (10-BIT ADDRESS)



15.2.2 GENERAL CALL ADDRESS SUPPORT

The addressing procedure for the I²C bus is such that the first byte after the START condition usually determines which device will be the slave addressed by the master. The exception is the general call address, which can address all devices. When this address is used, all devices should, in theory, respond with an acknowledge.

The general call address is one of eight addresses reserved for specific purposes by the I²C protocol. It consists of all 0's with R/W = 0.

The general call address is recognized when the General Call Enable bit (GCEN) is enabled (SSPCON2<7> is set). Following a START bit detect, 8-bits are shifted into SSPSR and the address is compared against SSPADD and is also compared to the general call address, fixed in hardware.

If the general call address matches, the SSPSR is transferred to the SSPBUF, the BF flag is set (eighth bit) and on the falling edge of the ninth bit ($\overline{\text{ACK}}$ bit), the SSPIF flag is set.

When the interrupt is serviced, the source for the interrupt can be checked by reading the contents of the SSPBUF to determine if the address was device specific, or a general call address.

In 10-bit mode, the SSPADD is required to be updated for the second half of the address to match and the UA bit is set (SSPSTAT<1>). If the general call address is sampled when GCEN is set, while the slave is configured in 10-bit address mode, then the second half of the address is not necessary, the UA bit will not be set and the slave will begin receiving data after the acknowledge (Figure 15-16).

FIGURE 15-16: SLAVE MODE GENERAL CALL ADDRESS SEQUENCE (7 OR 10-BIT MODE)

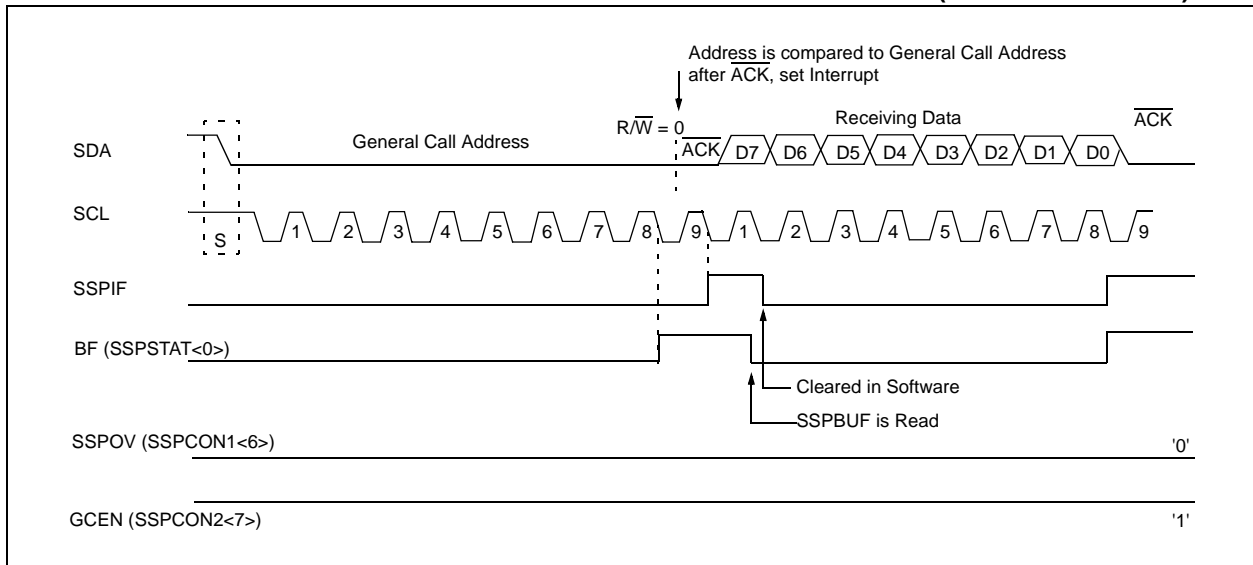

PIC17C7XX

15.2.3 SLEEP OPERATION

While in SLEEP mode, the I²C module can receive addresses or data and when an address match or complete byte transfer occurs, wake the processor from SLEEP (if the SSP interrupt is enabled).

15.2.4 EFFECTS OF A RESET

A RESET disables the SSP module and terminates the current transfer.

TABLE 15-3: REGISTERS ASSOCIATED WITH I²C OPERATION

Address	Name	Bit 7	Bit 6	Bit 5	Bit 4	Bit 3	Bit 2	Bit 1	Bit 0	POR, BOR	MCLR, WDT
07h, Unbanked	INTSTA	PEIF	T0CKIF	T0IF	INTF	PEIE	T0CKIE	T0IE	INTE	0000 0000	0000 0000
10h, Bank 4	PIR2	SSPIF	BCLIF	ADIF	—	CA4IF	CA3IF	TX2IF	RC2IF	000- 0000	000- 0000
11h, Bank 4	PIE2	SSPIE	BCLIE	ADIE	—	CA4IE	CA3IE	TX2IE	RC2IE	000- 0000	000- 0000
10h, Bank 6	SSPADD	Synchronous Serial Port (I ² C mode) Address Register								0000 0000	0000 0000
14h, Bank 6	SSPBUF	Synchronous Serial Port Receive Buffer/Transmit Register								xxxx xxxx	uuuu uuuu
11h, Bank 6	SSPCON1	WCOL	SSPOV	SSPEN	CKP	SSPM3	SSPM2	SSPM1	SSPM0	0000 0000	0000 0000
12h, Bank 6	SSPCON2	GCEN	ACKSTAT	ACKDT	ACKEN	RCEN	PEN	RSEN	SEN	0000 0000	0000 0000
13h, Bank 6	SSPSTAT	SMP	CKE	D \bar{A}	P	S	R \bar{W}	UA	BF	0000 0000	0000 0000

Legend: x = unknown, u = unchanged, - = unimplemented, read as '0'. Shaded cells are not used by the SSP in I²C mode.

15.2.5 MASTER MODE

Master mode of operation is supported by interrupt generation on the detection of the START and STOP conditions. The STOP (P) and START (S) bits are cleared from a RESET, or when the MSSP module is disabled. Control of the I²C bus may be taken when the P bit is set, or the bus is idle, with both the S and P bits clear.

In Master mode, the SCL and SDA lines are manipulated by the MSSP hardware.

The following events will cause SSP Interrupt Flag bit, SSPIF, to be set (SSP Interrupt if enabled):

- START condition
- STOP condition
- Data transfer byte transmitted/received
- Acknowledge transmit
- Repeated Start

FIGURE 15-17: SSP BLOCK DIAGRAM (I²C MASTER MODE)

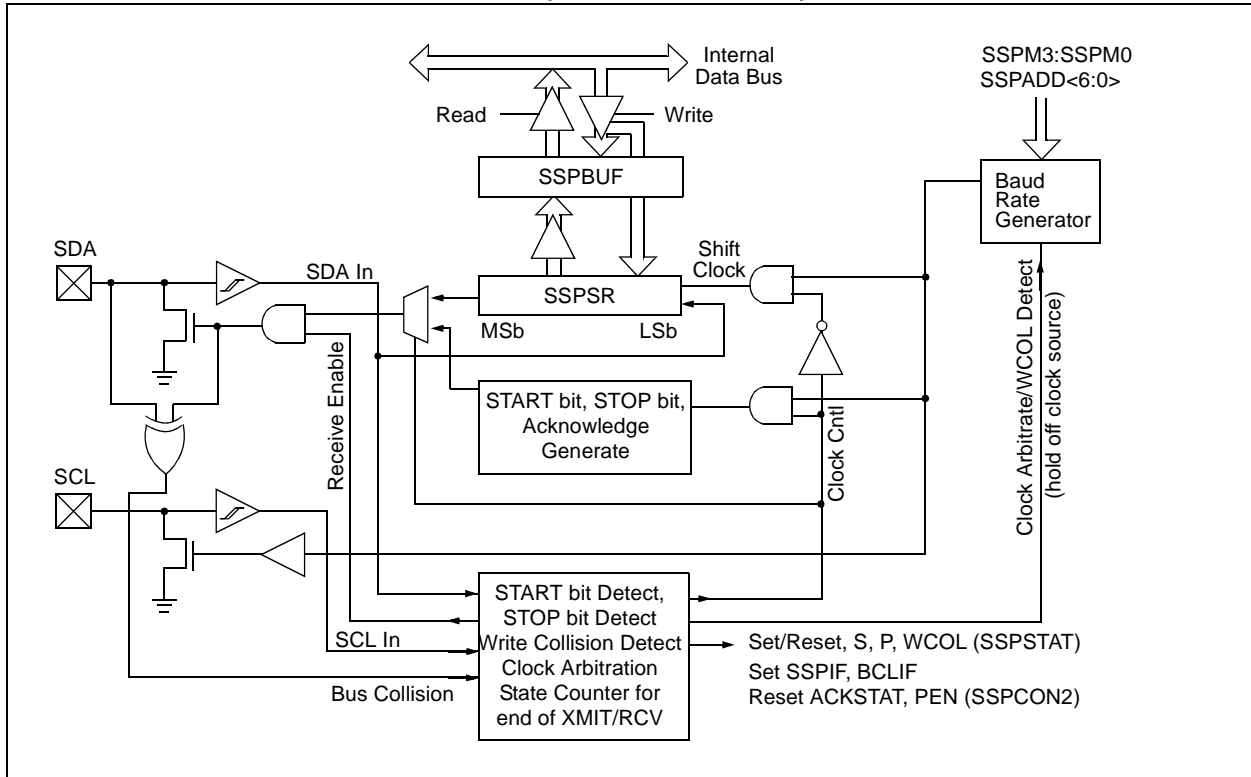

PIC17C7XX

15.2.6 MULTI-MASTER MODE

In Multi-Master mode, the interrupt generation on the detection of the START and STOP conditions allows the determination of when the bus is free. The STOP (P) and START (S) bits are cleared from a RESET, or when the MSSP module is disabled. Control of the I²C bus may be taken when bit P (SSPSTAT<4>) is set, or the bus is idle, with both the S and P bits clear. When the bus is busy, enabling the SSP interrupt will generate the interrupt when the STOP condition occurs.

In Multi-Master operation, the SDA line must be monitored for arbitration, to see if the signal level is the expected output level. This check is performed in hardware, with the result placed in the BCLIF bit.

The states where arbitration can be lost are:

- Address Transfer
- Data Transfer
- A START Condition
- A Repeated Start Condition
- An Acknowledge Condition

15.2.7 I²C MASTER MODE SUPPORT

Master mode is enabled by setting and clearing the appropriate SSPM bits in SSPCON1 and by setting the SSPEN bit. Once Master mode is enabled, the user has six options.

- Assert a START condition on SDA and SCL.
- Assert a Repeated Start condition on SDA and SCL.
- Write to the SSPBUF register initiating transmission of data/address.
- Generate a STOP condition on SDA and SCL.
- Configure the I²C port to receive data.
- Generate an Acknowledge condition at the end of a received byte of data.

Note: The MSSP Module, when configured in I²C Master mode, does not allow queuing of events. For instance: The user is not allowed to initiate a START condition and immediately write the SSPBUF register to initiate transmission before the START condition is complete. In this case, the SSPBUF will not be written to and the WCOL bit will be set, indicating that a write to the SSPBUF did not occur.

15.2.7.1 I²C Master Mode Operation

The master device generates all of the serial clock pulses and the START and STOP conditions. A transfer is ended with a STOP condition or with a Repeated Start condition. Since the Repeated Start condition is also the beginning of the next serial transfer, the I²C bus will not be released.

In Master Transmitter mode, serial data is output through SDA, while SCL outputs the serial clock. The first byte transmitted contains the slave address of the receiving device (7 bits) and the Read/Write (R/W) bit. In this case, the R/W bit will be logic '0'. Serial data is transmitted 8 bits at a time. After each byte is transmitted, an acknowledge bit is received. START and STOP conditions are output to indicate the beginning and the end of a serial transfer.

In Master Receive mode, the first byte transmitted contains the slave address of the transmitting device (7 bits) and the R/W bit. In this case, the R/W bit will be logic '1'. Thus, the first byte transmitted is a 7-bit slave address, followed by a '1' to indicate receive bit. Serial data is received via SDA, while SCL outputs the serial clock. Serial data is received 8 bits at a time. After each byte is received, an acknowledge bit is transmitted. START and STOP conditions indicate the beginning and end of transmission.

The baud rate generator used for SPI mode operation is now used to set the SCL clock frequency for either 100 kHz, 400 kHz, or 1 MHz I²C operation. The baud rate generator reload value is contained in the lower 7 bits of the SSPADD register. The baud rate generator will automatically begin counting on a write to the SSPBUF. Once the given operation is complete (i.e., transmission of the last data bit is followed by ACK), the internal clock will automatically stop counting and the SCL pin will remain in its last state

A typical transmit sequence would go as follows:

- a) The user generates a START Condition by setting the START enable bit (SEN) in SSPCON2.
- b) SSPIF is set. The module will wait the required START time before any other operation takes place.
- c) The user loads the SSPBUF with address to transmit.
- d) Address is shifted out the SDA pin until all 8 bits are transmitted.
- e) The MSSP Module shifts in the ACK bit from the slave device and writes its value into the SSPCON2 register (SSPCON2<6>).
- f) The module generates an interrupt at the end of the ninth clock cycle by setting SSPIF.
- g) The user loads the SSPBUF with eight bits of data.
- h) DATA is shifted out the SDA pin until all 8 bits are transmitted.
- i) The MSSP Module shifts in the ACK bit from the slave device, and writes its value into the SSPCON2 register (SSPCON2<6>).
- j) The MSSP module generates an interrupt at the end of the ninth clock cycle by setting the SSPIF bit.
- k) The user generates a STOP condition by setting the STOP enable bit PEN in SSPCON2.
- l) Interrupt is generated once the STOP condition is complete.

15.2.8 BAUD RATE GENERATOR

In I²C Master mode, the reload value for the BRG is located in the lower 7 bits of the SSPADD register (Figure 15-18). When the BRG is loaded with this value, the BRG counts down to 0 and stops until another reload has taken place. The BRG count is decremented twice per instruction cycle (T_{cy}), on the Q2 and Q4 clock.

In I²C Master mode, the BRG is reloaded automatically. If Clock Arbitration is taking place, for instance, the BRG will be reloaded when the SCL pin is sampled high (Figure 15-19).

FIGURE 15-18: BAUD RATE GENERATOR BLOCK DIAGRAM

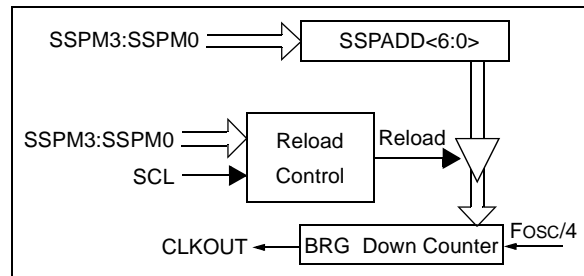
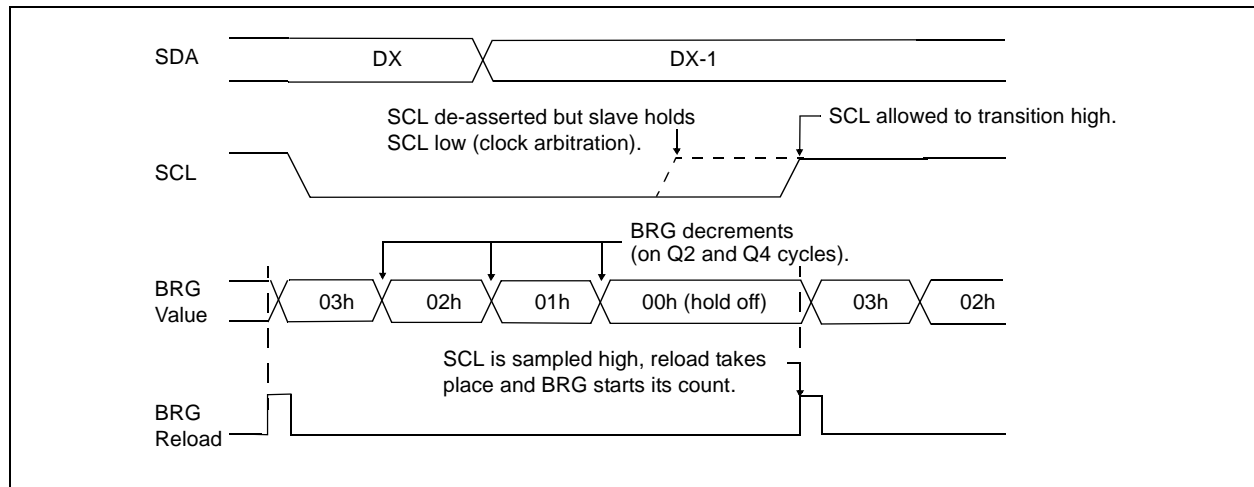

FIGURE 15-19: BAUD RATE GENERATOR TIMING WITH CLOCK ARBITRATION



PIC17C7XX

15.2.9 I²C MASTER MODE START CONDITION TIMING

To initiate a START condition, the user sets the START condition enable bit, SEN (SSPCON2<0>). If the SDA and SCL pins are sampled high, the baud rate generator is reloaded with the contents of SSPADD<6:0> and starts its count. If SCL and SDA are both sampled high when the baud rate generator times out (TBRG), the SDA pin is driven low. The action of the SDA being driven low while SCL is high is the START condition and causes the S bit (SSPSTAT<3>) to be set. Following this, the baud rate generator is reloaded with the contents of SSPADD<6:0> and resumes its count. When the baud rate generator times out (TBRG), the SEN bit (SSPCON2<0>) will be automatically cleared by hardware, the baud rate generator is suspended, leaving the SDA line held low and the START condition is complete.

Note: If at the beginning of START condition, the SDA and SCL pins are already sampled low, or if during the START condition, the SCL line is sampled low before the SDA line is driven low, a bus collision occurs. The Bus Collision Interrupt Flag (BCLIF) is set, the START condition is aborted and the I²C module is reset into its IDLE state.

15.2.9.1 WCOL Status Flag

If the user writes the SSPBUF when a START sequence is in progress, then WCOL is set and the contents of the buffer are unchanged (the write doesn't occur).

Note: Because queuing of events is not allowed, writing to the lower 5 bits of SSPCON2 is disabled until the START condition is complete.

FIGURE 15-20: FIRST START BIT TIMING

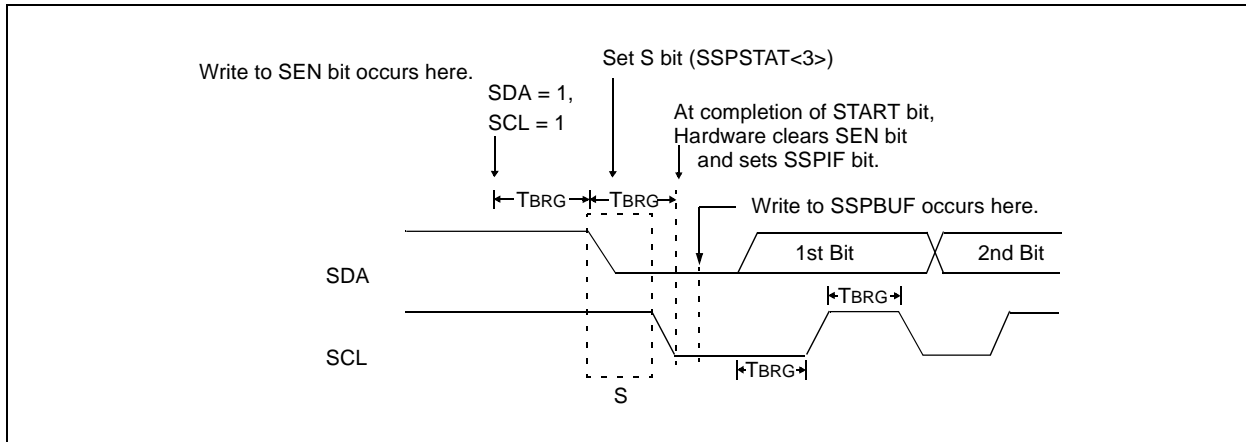
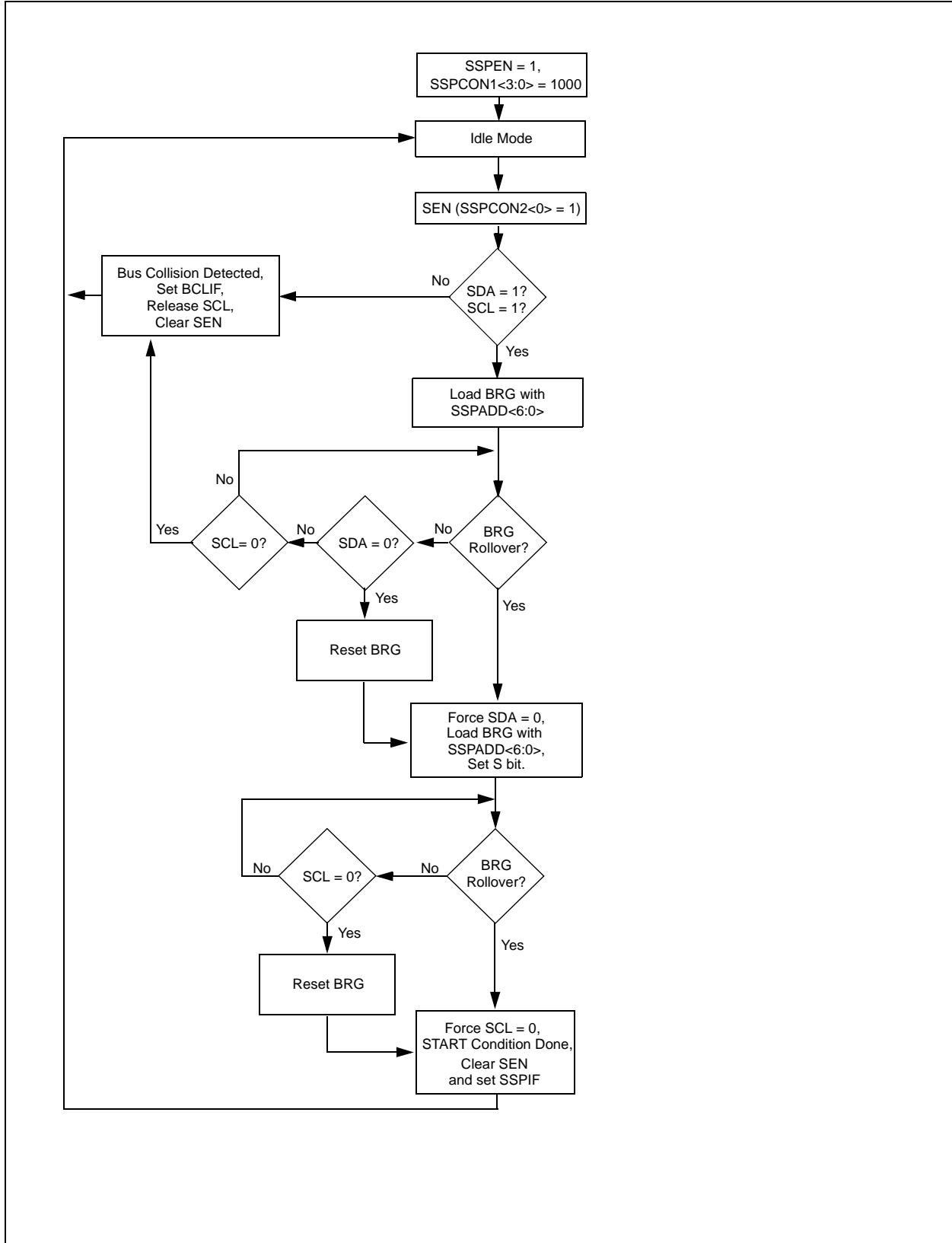

FIGURE 15-21: START CONDITION FLOW CHART



PIC17C7XX

15.2.10 I²C MASTER MODE REPEATED START CONDITION TIMING

A Repeated Start condition occurs when the RSEN bit (SSPCON2<1>) is programmed high and the I²C module is in the idle state. When the RSEN bit is set, the SCL pin is asserted low. When the SCL pin is sampled low, the baud rate generator is loaded with the contents of SSPADD<6:0> and begins counting. The SDA pin is released (brought high) for one baud rate generator count (TBRG). When the baud rate generator times out, if SDA is sampled high, the SCL pin will be de-asserted (brought high). When SCL is sampled high the baud rate generator is reloaded with the contents of SSPADD<6:0> and begins counting. SDA and SCL must be sampled high for one TBRG. This action is then followed by assertion of the SDA pin (SDA is low) for one TBRG while SCL is high. Following this, the RSEN bit in the SSPCON2 register will be automatically cleared and the baud rate generator is not reloaded, leaving the SDA pin held low. As soon as a START condition is detected on the SDA and SCL pins, the S bit (SSPSTAT<3>) will be set. The SSPIF bit will not be set until the baud rate generator has timed out.

Immediately following the SSPIF bit getting set, the user may write the SSPBUF with the 7-bit address in 7-bit mode, or the default first address in 10-bit mode. After the first eight bits are transmitted and an ACK is received, the user may then transmit an additional eight bits of address (10-bit mode), or eight bits of data (7-bit mode).

15.2.10.1 WCOL status flag

If the user writes the SSPBUF when a Repeated Start sequence is in progress, then WCOL is set and the contents of the buffer are unchanged (the write doesn't occur).

Note: Because queuing of events is not allowed, writing of the lower 5 bits of SSPCON2 is disabled until the Repeated Start condition is complete.

- Note 1:** If the RSEN is programmed while any other event is in progress, it will not take effect.
- 2:** A bus collision during the Repeated Start condition occurs if:
- SDA is sampled low when SCL goes from low to high.
 - SCL goes low before SDA is asserted low. This may indicate that another master is attempting to transmit a data "1".

FIGURE 15-22: REPEAT START CONDITION WAVEFORM

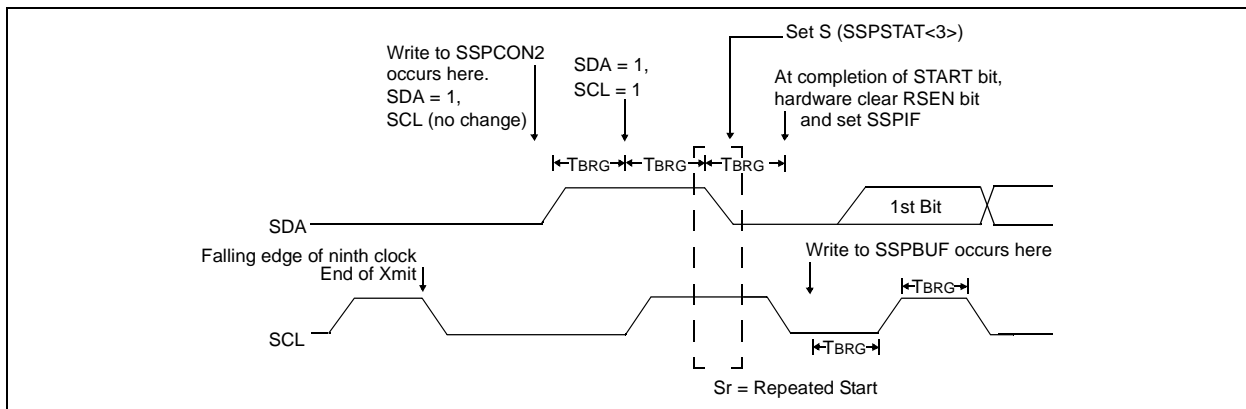
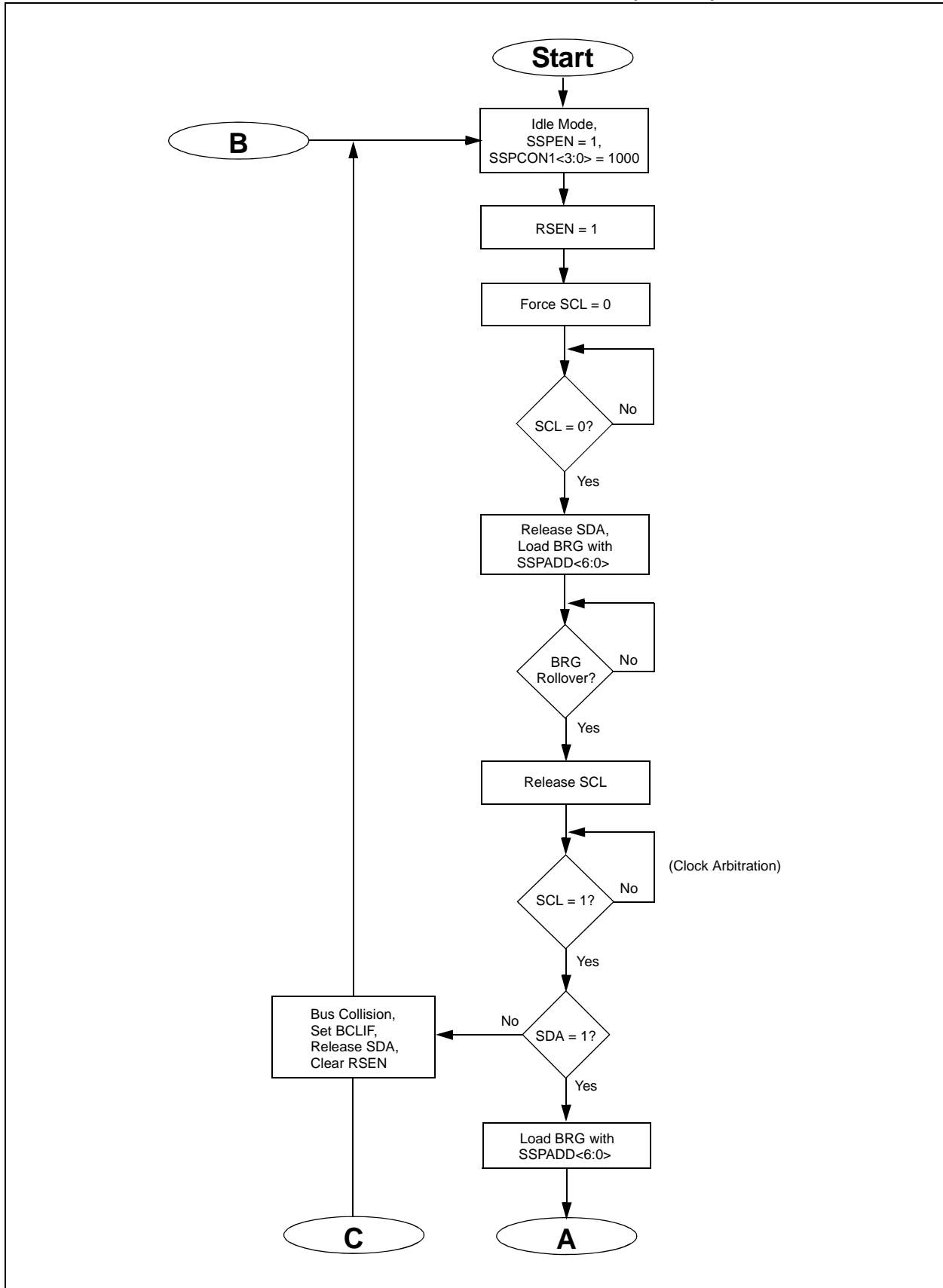
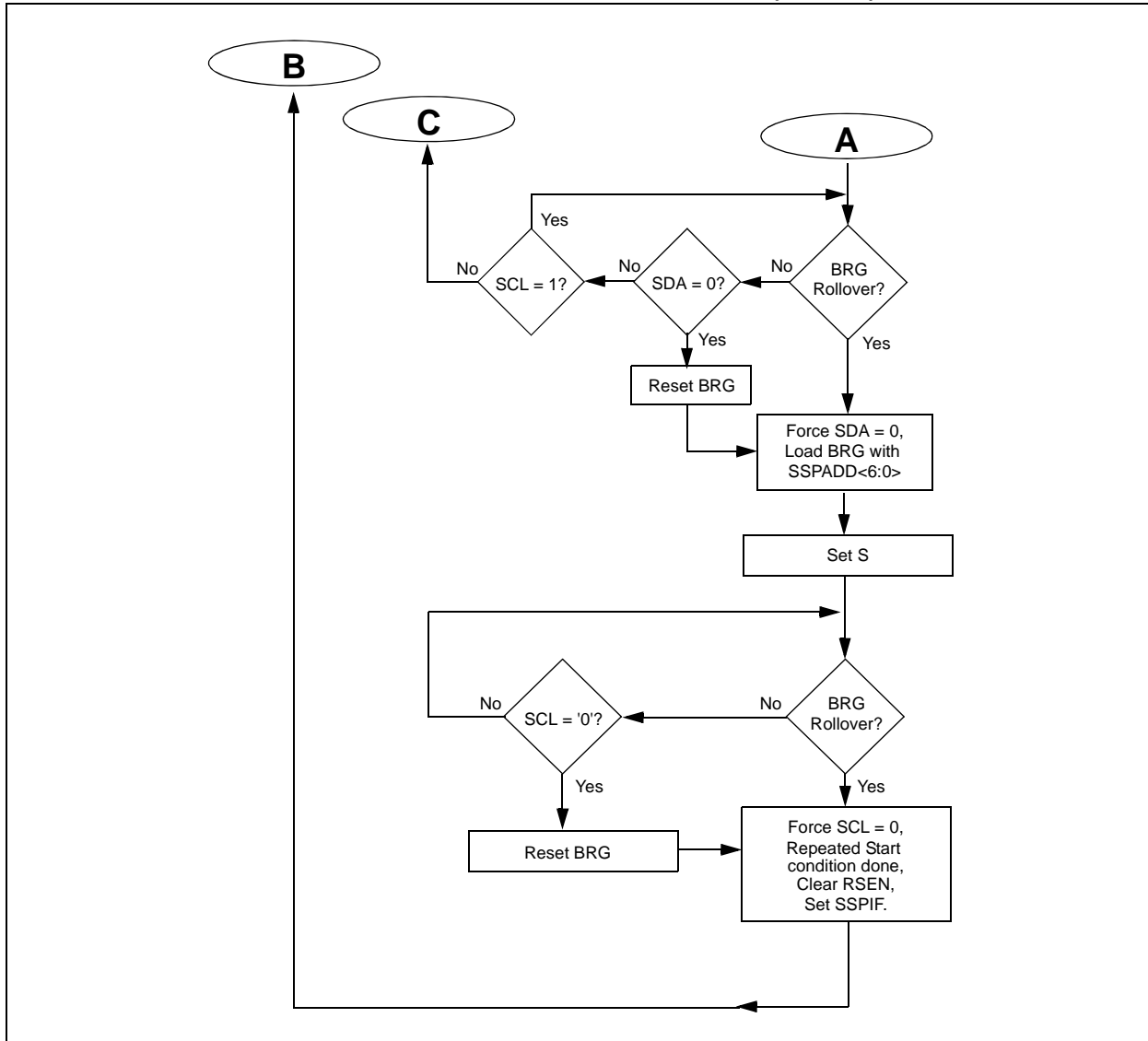

FIGURE 15-23: REPEATED START CONDITION FLOW CHART (PAGE 1)



PIC17C7XX

FIGURE 15-24: REPEATED START CONDITION FLOW CHART (PAGE 2)



15.2.11 I²C MASTER MODE TRANSMISSION

Transmission of a data byte, a 7-bit address, or either half of a 10-bit address, is accomplished by simply writing a value to SSPBUF register. This action will set the buffer full flag (BF) and allow the baud rate generator to begin counting and start the next transmission. Each bit of address/data will be shifted out onto the SDA pin after the falling edge of SCL is asserted (see data hold time spec). SCL is held low for one baud rate generator roll over count (TBRG). Data should be valid before SCL is released high (see Data setup time spec). When the SCL pin is released high, it is held that way for TBRG, the data on the SDA pin must remain stable for that duration and some hold time after the next falling edge of SCL. After the eighth bit is shifted out (the falling edge of the eighth clock), the BF flag is cleared and the master releases SDA, allowing the slave device being addressed to respond with an ACK bit during the ninth bit time, if an address match occurs or if data was received properly. The status of ACK is read into the ACKDT on the falling edge of the ninth clock. If the master receives an acknowledge, the acknowledge status bit (AKSTAT) is cleared. If not, the bit is set. After the ninth clock, the SSPIF is set and the master clock (baud rate generator) is suspended until the next data byte is loaded into the SSPBUF, leaving SCL low and SDA unchanged (Figure 15-26).

After the write to the SSPBUF, each bit of address will be shifted out on the falling edge of SCL until all seven address bits and the R/W bit are completed. On the falling edge of the eighth clock, the master will de-assert the SDA pin, allowing the slave to respond with an acknowledge. On the falling edge of the ninth clock, the master will sample the SDA pin to see if the address was recognized by a slave. The status of the ACK bit is loaded into the ACKSTAT status bit (SSPCON2<6>). Following the falling edge of the ninth clock transmission of the address, the SSPIF is set, the BF flag is cleared and the baud rate generator is turned off until another write to the SSPBUF takes place, holding SCL low and allowing SDA to float.

15.2.11.1 BF Status Flag

In Transmit mode, the BF bit (SSPSTAT<0>) is set when the CPU writes to SSPBUF and is cleared when all 8 bits are shifted out.

15.2.11.2 WCOL Status Flag

If the user writes the SSPBUF when a transmit is already in progress (i.e., SSPSR is still shifting out a data byte), then WCOL is set and the contents of the buffer are unchanged (the write doesn't occur).

WCOL must be cleared in software.

15.2.11.3 AKSTAT Status Flag

In Transmit mode, the AKSTAT bit (SSPCON2<6>) is cleared when the slave has sent an acknowledge (ACK = 0) and is set when the slave does not acknowledge (ACK = 1). A slave sends an acknowledge when it has recognized its address (including a general call), or when the slave has properly received its data.

PIC17C7XX

FIGURE 15-25: MASTER TRANSMIT FLOW CHART

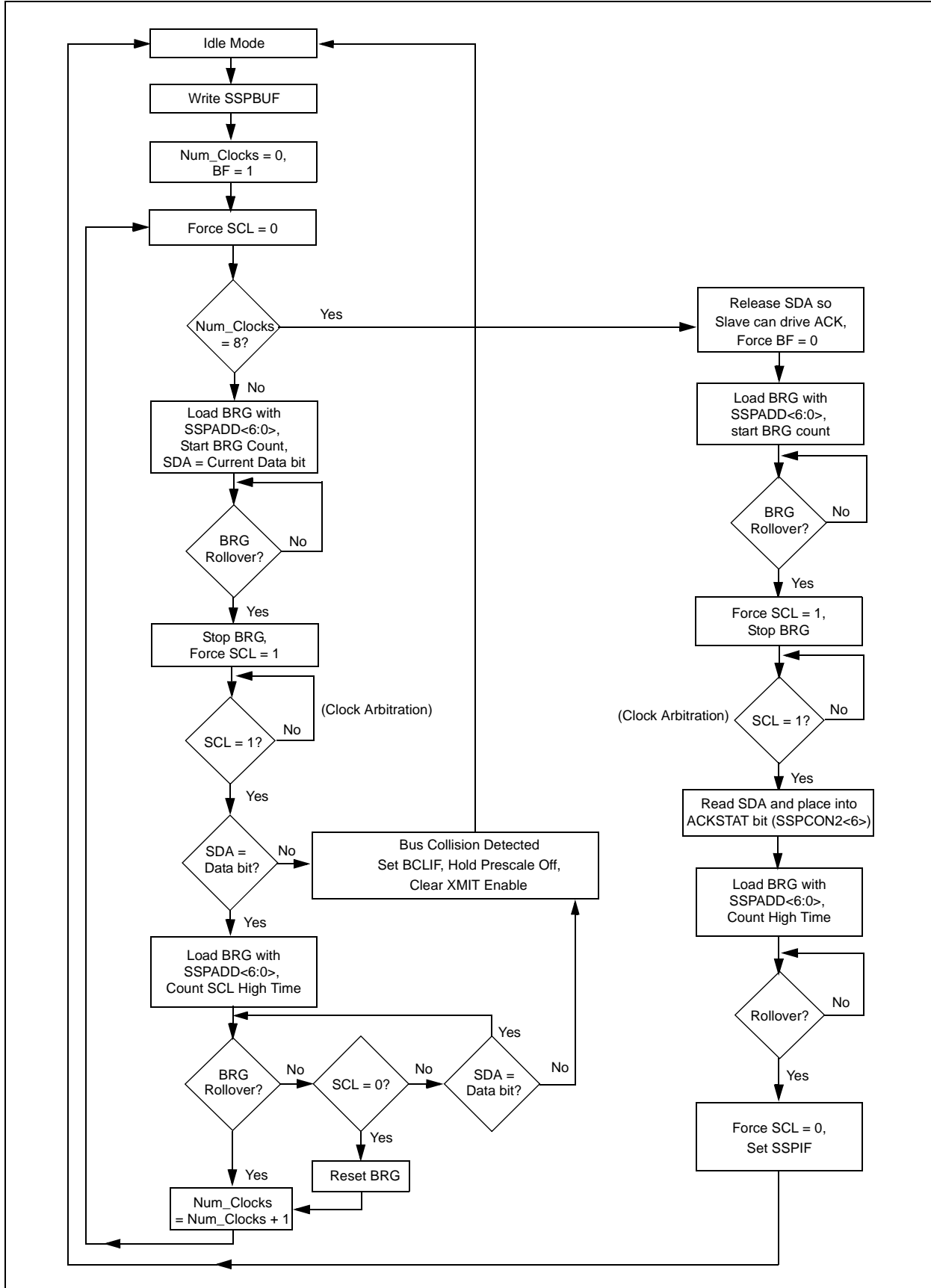
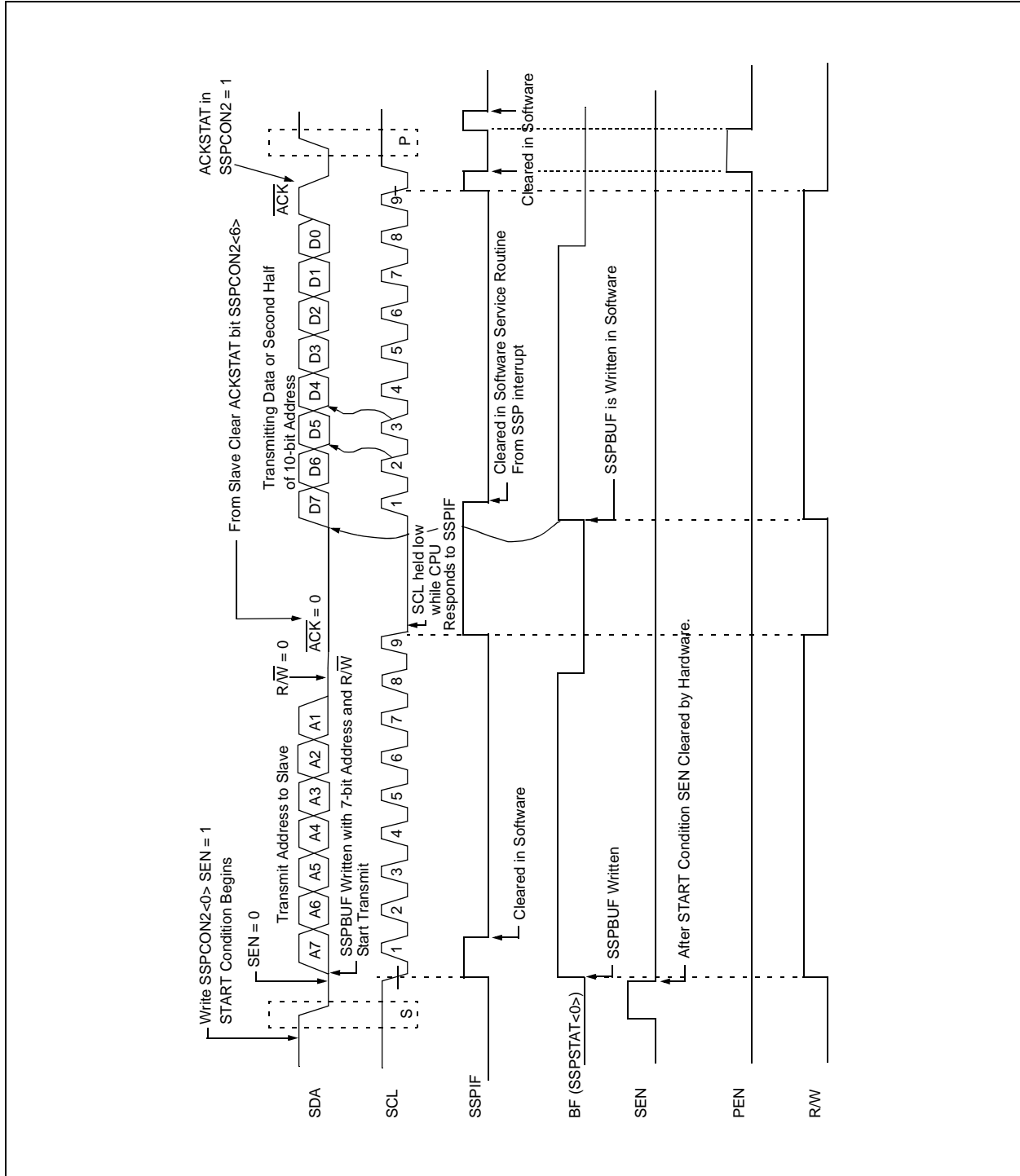

FIGURE 15-26: I²C MASTER MODE TIMING (TRANSMISSION, 7 OR 10-BIT ADDRESS)



PIC17C7XX

15.2.12 I²C MASTER MODE RECEPTION

Master mode reception is enabled by programming the receive enable bit, RCEN (SSPCON2<3>).

Note: The SSP Module must be in an IDLE STATE before the RCEN bit is set, or the RCEN bit will be disregarded.

The baud rate generator begins counting and on each rollover, the state of the SCL pin changes (high to low/low to high) and data is shifted into the SSPSR. After the falling edge of the eighth clock, the receive enable flag is automatically cleared, the contents of the SSPSR are loaded into the SSPBUF, the BF flag is set, the SSPIF is set and the baud rate generator is suspended from counting, holding SCL low. The SSP is now in IDLE state, awaiting the next command. When the buffer is read by the CPU, the BF flag is automatically cleared. The user can then send an acknowledge bit at the end of reception, by setting the acknowledge sequence enable bit, ACKEN (SSPCON2<4>).

15.2.12.1 BF Status Flag

In receive operation, BF is set when an address or data byte is loaded into SSPBUF from SSPSR. It is cleared when SSPBUF is read.

15.2.12.2 SSPOV Status Flag

In receive operation, SSPOV is set when 8 bits are received into the SSPSR, and the BF flag is already set from a previous reception.

15.2.12.3 WCOL Status Flag

If the user writes the SSPBUF when a receive is already in progress (i.e., SSPSR is still shifting in a data byte), then WCOL is set and the contents of the buffer are unchanged (the write doesn't occur).

FIGURE 15-27: MASTER RECEIVER FLOW CHART

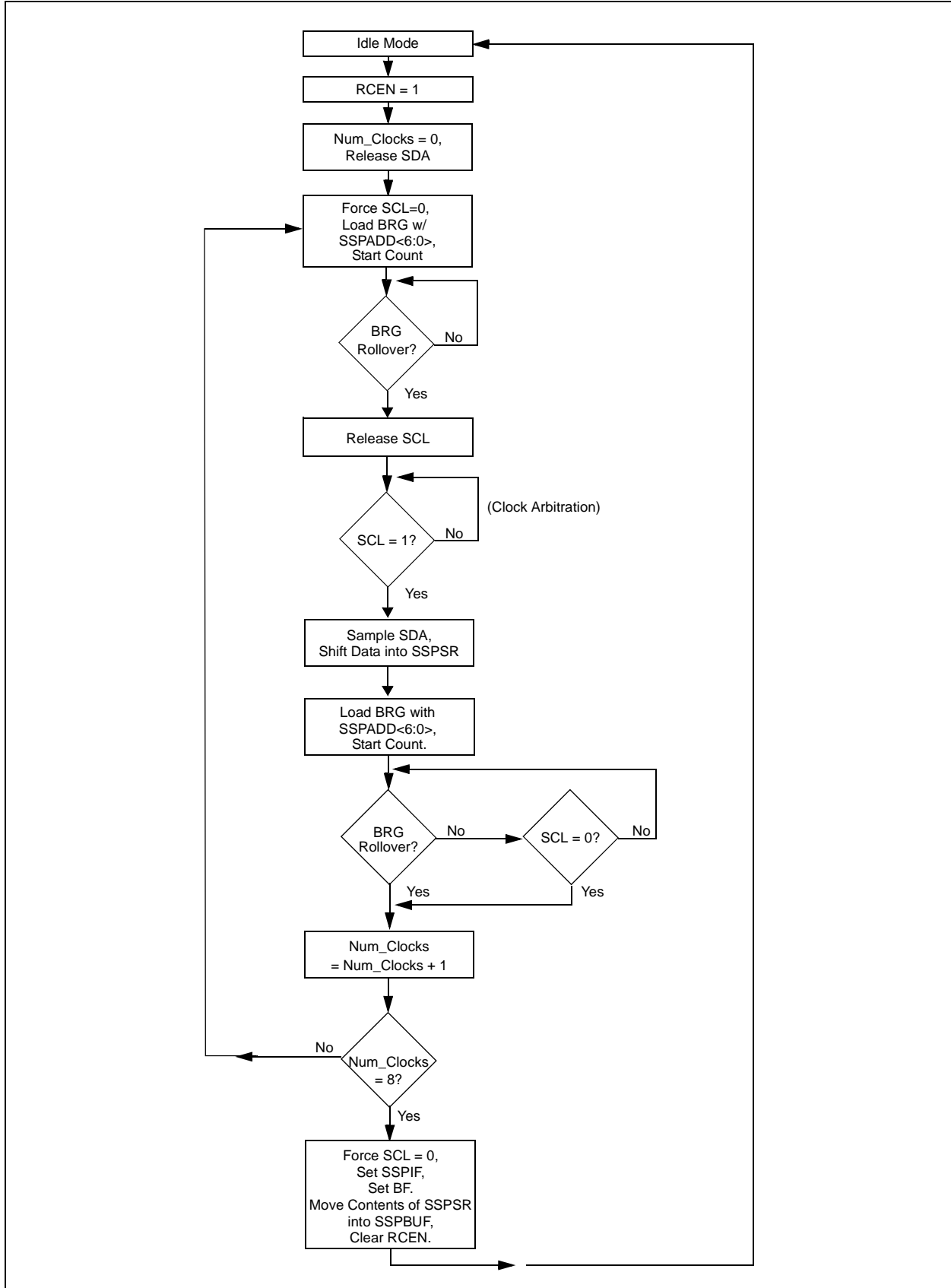

PIC17C7XX

FIGURE 15-28: I²C MASTER MODE TIMING (RECEPTION 7-BIT ADDRESS)

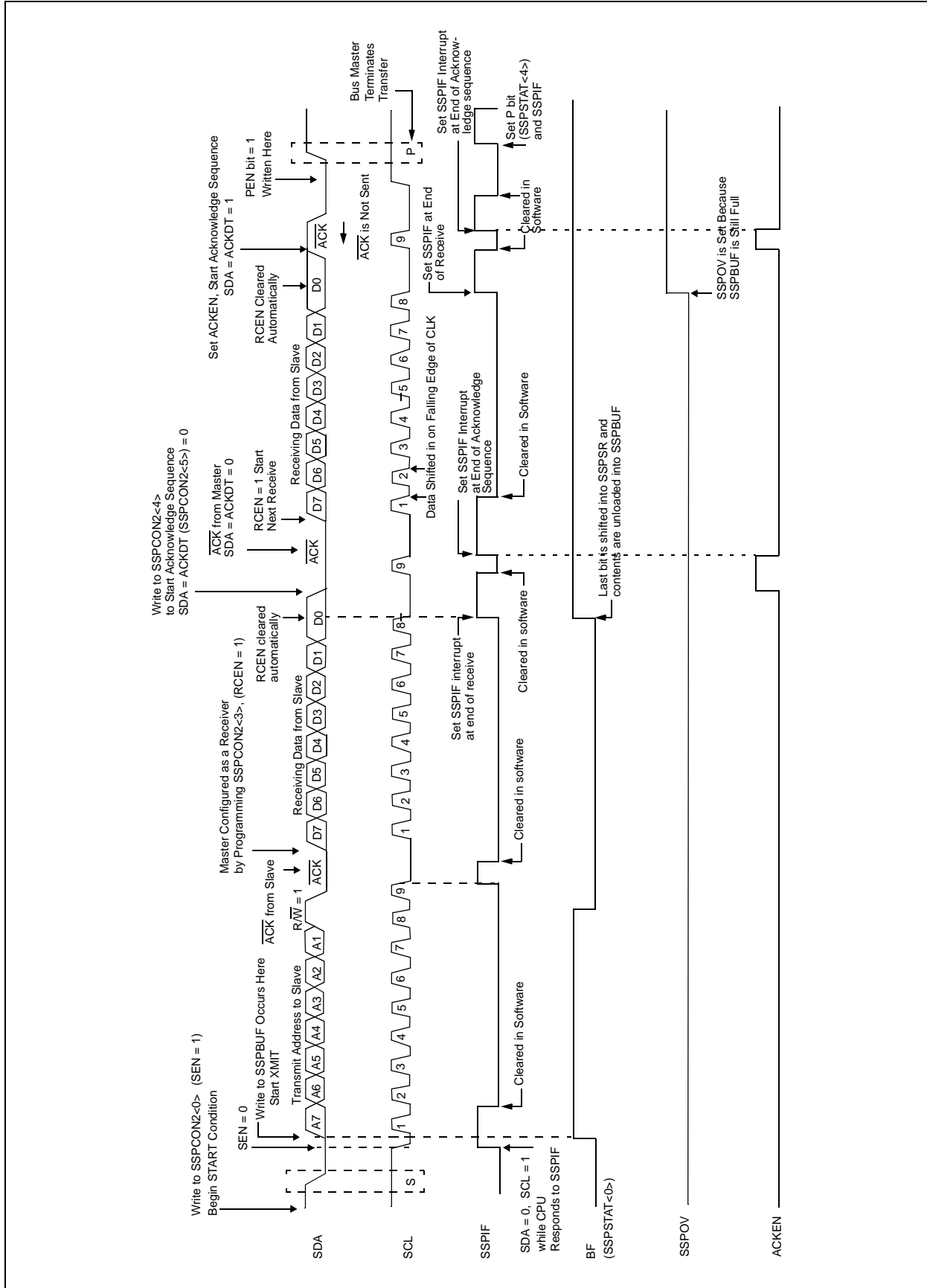

15.2.13 ACKNOWLEDGE SEQUENCE TIMING

An acknowledge sequence is enabled by setting the acknowledge sequence enable bit, ACKEN (SSPCON2<4>). When this bit is set, the SCL pin is pulled low and the contents of the acknowledge data bit is presented on the SDA pin. If the user wishes to generate an acknowledge, then the ACKDT bit should be cleared. If not, the user should set the ACKDT bit before starting an acknowledge sequence. The baud rate generator then counts for one rollover period (TBRG), and the SCL pin is de-asserted (pulled high). When the SCL pin is sampled high (clock arbitration), the baud rate generator counts for TBRG. The SCL pin is then pulled low. Following this, the ACKEN bit is automatically cleared, the baud rate generator is turned off and the SSP module then goes into IDLE mode (Figure 15-29).

15.2.13.1 WCOL Status Flag

If the user writes the SSPBUF when an acknowledge sequence is in progress, then WCOL is set and the contents of the buffer are unchanged (the write doesn't occur).

FIGURE 15-29: ACKNOWLEDGE SEQUENCE WAVEFORM

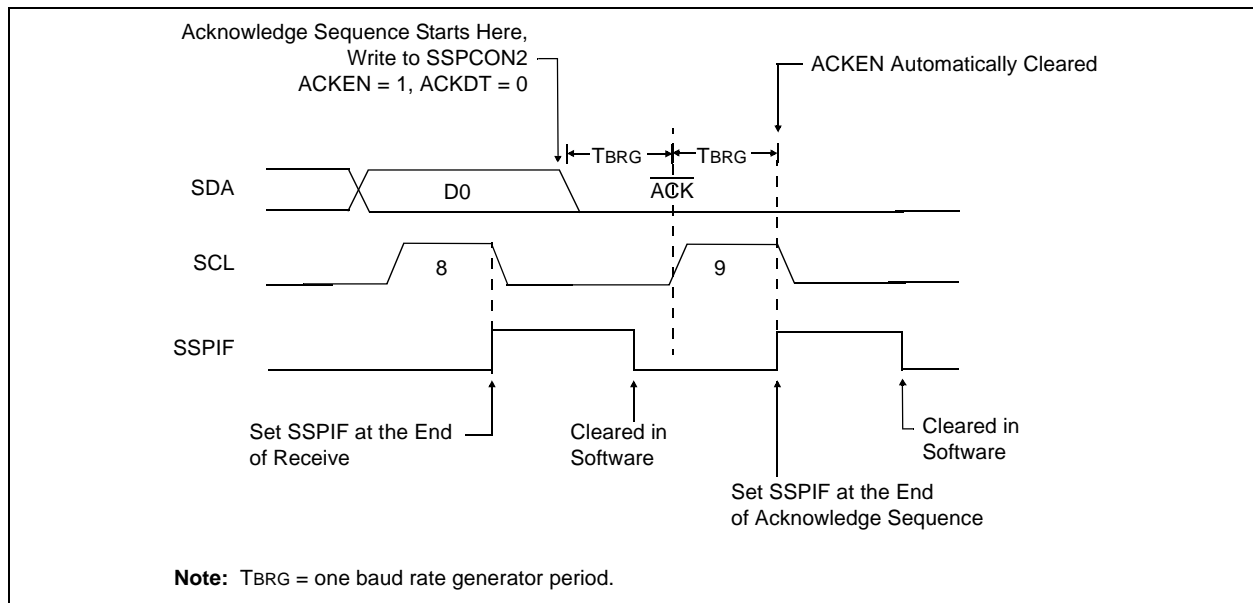

PIC17C7XX

FIGURE 15-30: ACKNOWLEDGE FLOW CHART

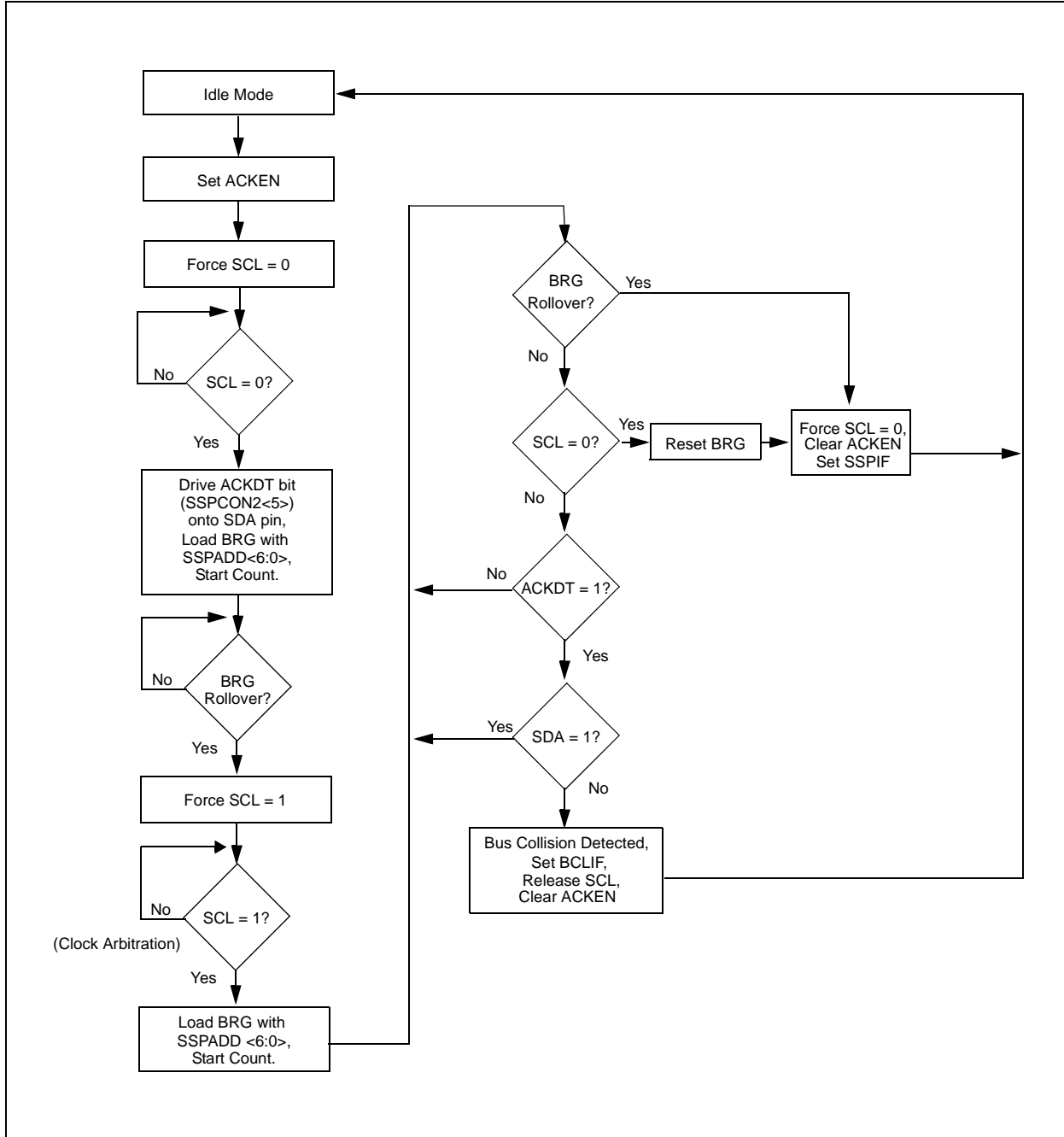

15.2.14 STOP CONDITION TIMING

A STOP bit is asserted on the SDA pin at the end of a receive/transmit by setting the Stop Sequence Enable bit PEN (SSPCON2<2>). At the end of a receive/transmit the SCL line is held low after the falling edge of the ninth clock. When the PEN bit is set, the master will assert the SDA line low. When the SDA line is sampled low, the baud rate generator is reloaded and counts down to '0'. When the baud rate generator times out, the SCL pin will be brought high and one TBRG (baud rate generator rollover count) later, the SDA pin will be de-asserted. When the SDA pin is sampled high while SCL is high, the P bit (SSPSTAT<4>) is set. A TBRG later, the PEN bit is cleared and the SSPIF bit is set (Figure 15-31).

Whenever the firmware decides to take control of the bus, it will first determine if the bus is busy by checking the S and P bits in the SSPSTAT register. If the bus is busy, then the CPU can be interrupted (notified) when a STOP bit is detected (i.e., bus is free).

15.2.14.1 WCOL Status Flag

If the user writes the SSPBUF when a STOP sequence is in progress, then WCOL is set and the contents of the buffer are unchanged (the write doesn't occur).

FIGURE 15-31: STOP CONDITION RECEIVE OR TRANSMIT MODE

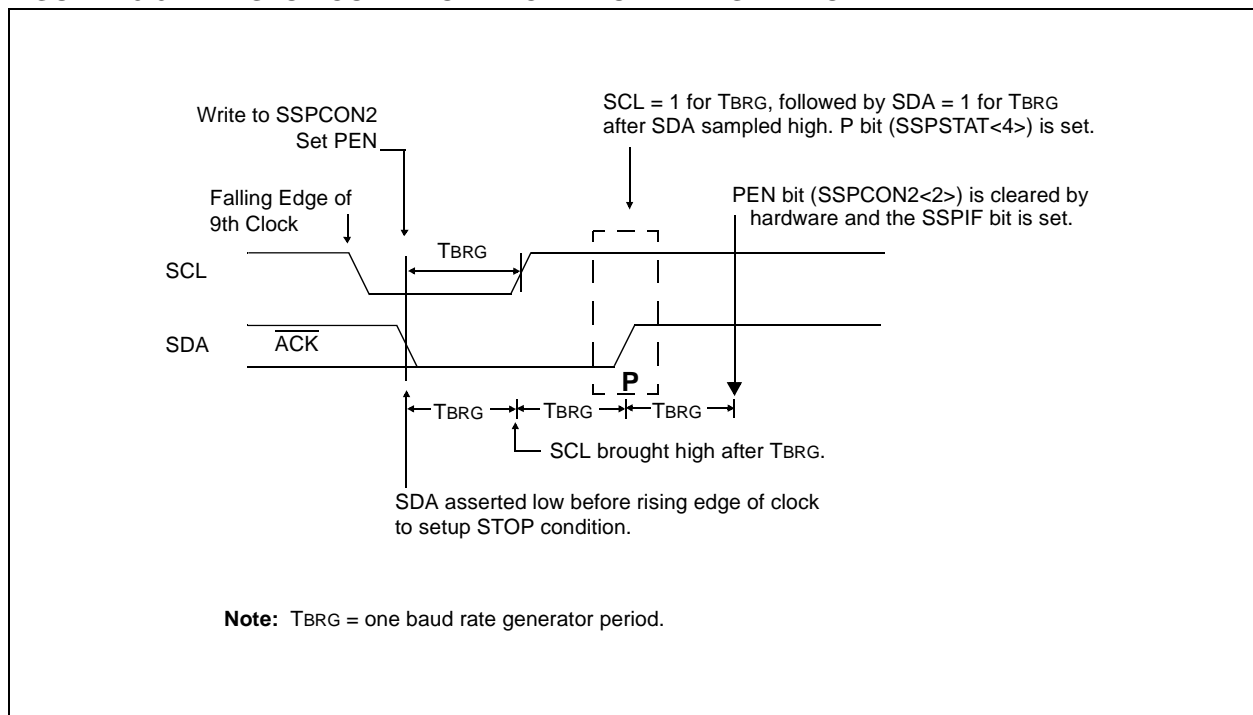

PIC17C7XX

FIGURE 15-32: STOP CONDITION FLOW CHART

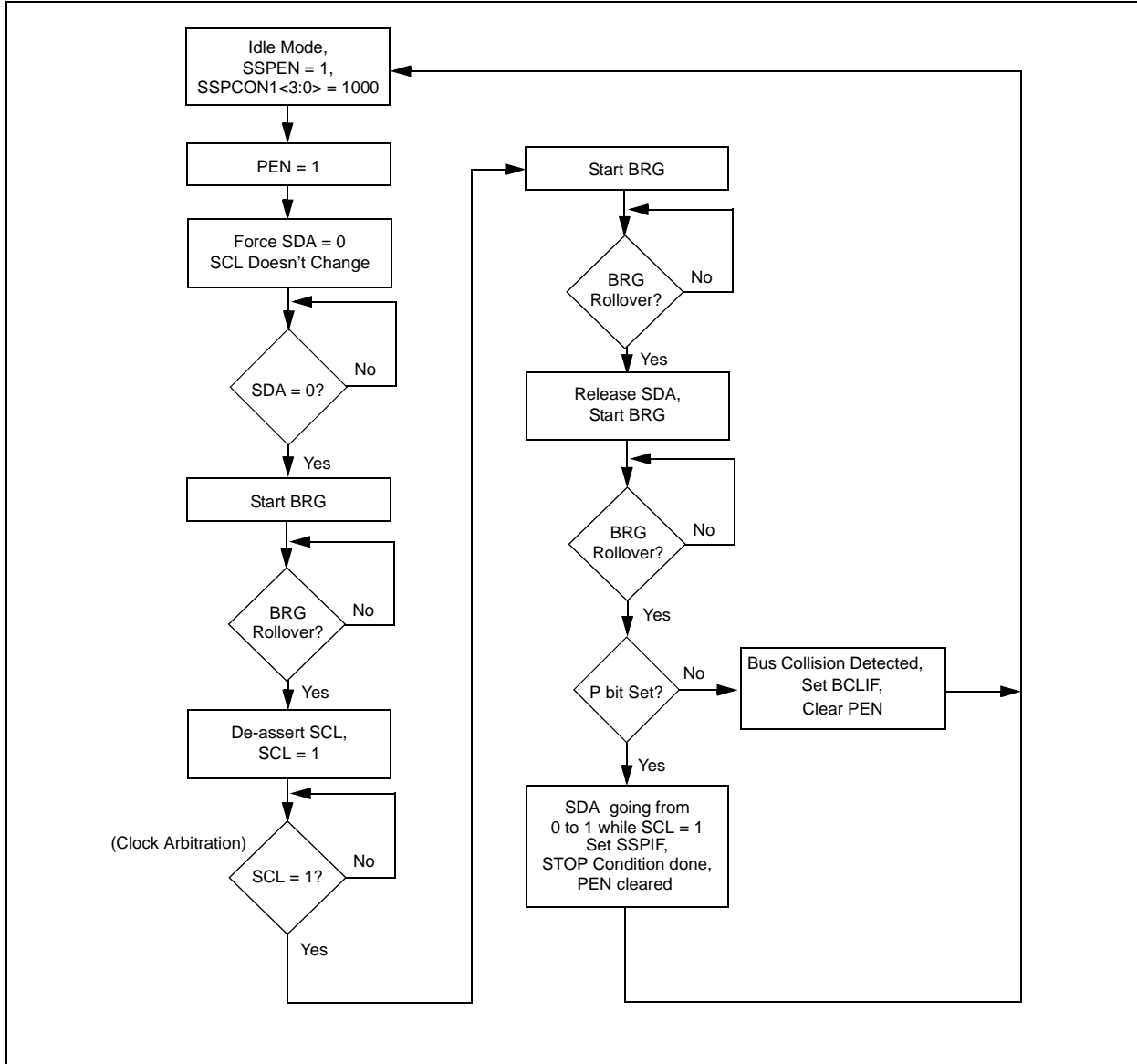

15.2.15 CLOCK ARBITRATION

Clock arbitration occurs when the master, during any receive, transmit, or Repeated Start/Stop condition, deasserts the SCL pin (SCL allowed to float high). When the SCL pin is allowed to float high, the baud rate generator (BRG) is suspended from counting until the SCL pin is actually sampled high. When the SCL pin is sampled high, the baud rate generator is reloaded with the contents of SSPADD<6:0> and begins counting. This ensures that the SCL high time will always be at least one BRG rollover count, in the event that the clock is held low by an external device (Figure 15-33).

15.2.16 SLEEP OPERATION

While in SLEEP mode, the I²C module can receive addresses or data and when an address match or complete byte transfer occurs, wake the processor from SLEEP (if the SSP interrupt is enabled).

15.2.17 EFFECTS OF A RESET

A RESET disables the SSP module and terminates the current transfer.

FIGURE 15-33: CLOCK ARBITRATION TIMING IN MASTER TRANSMIT MODE

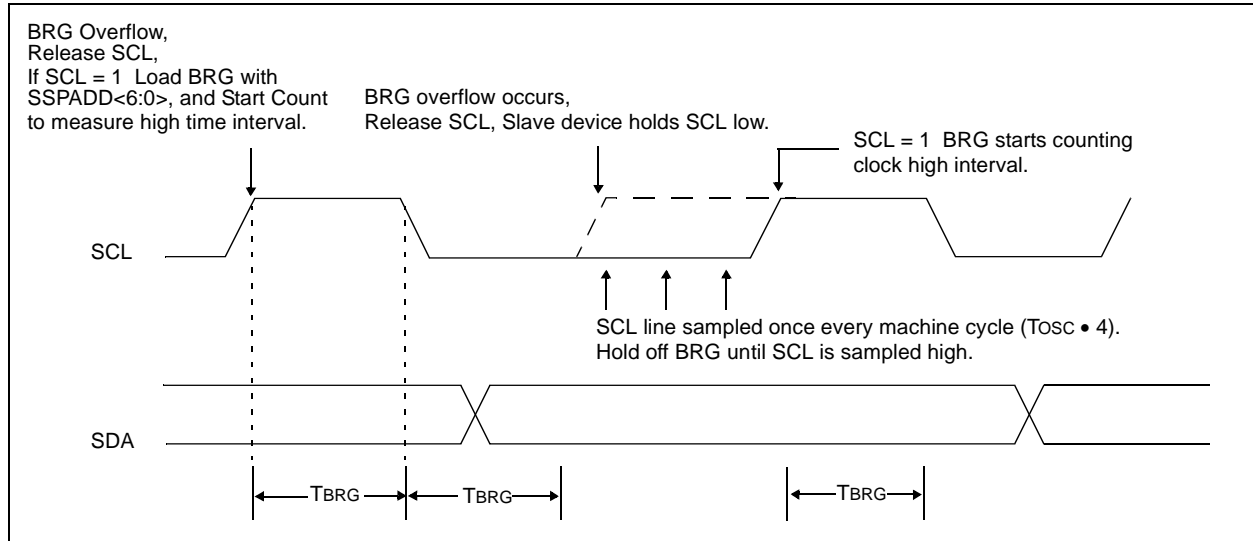

PIC17C7XX

15.2.18 MULTI-MASTER COMMUNICATION, BUS COLLISION AND BUS ARBITRATION

Multi-Master mode support is achieved by bus arbitration. When the master outputs address/data bits onto the SDA pin, arbitration takes place when the master outputs a '1' on SDA, by letting SDA float high and another master asserts a '0'. When the SCL pin floats high, data should be stable. If the expected data on SDA is a '1' and the data sampled on the SDA pin = '0', then a bus collision has taken place. The master will set the Bus Collision Interrupt Flag, BCLIF and reset the I²C port to its IDLE state (Figure 15-34).

If a transmit was in progress when the bus collision occurred, the transmission is halted, the BF flag is cleared, the SDA and SCL lines are de-asserted and the SSPBUF can be written to. When the user services the bus collision Interrupt Service Routine and if the I²C bus is free, the user can resume communication by asserting a START condition.

If a START, Repeated Start, STOP, or Acknowledge condition was in progress when the bus collision occurred, the condition is aborted, the SDA and SCL lines are de-asserted and the respective control bits in the SSPCON2 register are cleared. When the user services the bus collision Interrupt Service Routine, and if the I²C bus is free, the user can resume communication by asserting a START condition.

The master will continue to monitor the SDA and SCL pins and if a STOP condition occurs, the SSPIF bit will be set.

A write to the SSPBUF will start the transmission of data at the first data bit, regardless of where the transmitter left off when bus collision occurred.

In Multi-Master mode, the interrupt generation on the detection of START and STOP conditions allows the determination of when the bus is free. Control of the I²C bus can be taken when the P bit is set in the SSPSTAT register, or the bus is idle and the S and P bits are cleared.

FIGURE 15-34: BUS COLLISION TIMING FOR TRANSMIT AND ACKNOWLEDGE

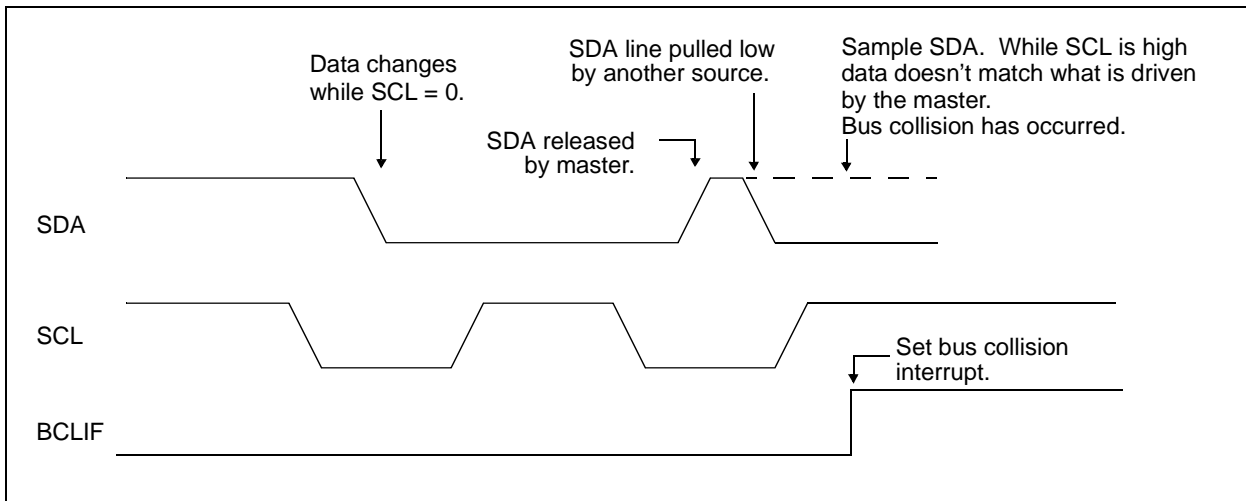

15.2.18.1 Bus Collision During a START Condition

During a START condition, a bus collision occurs if:

- SDA or SCL are sampled low at the beginning of the START condition (Figure 15-35).
- SCL is sampled low before SDA is asserted low (Figure 15-36).

During a START condition, both the SDA and the SCL pins are monitored.

If:

the SDA pin is already low
or the SCL pin is already low,

then:

the START condition is aborted,
and the BCLIF flag is set,
and the SSP module is reset to its IDLE state
 (Figure 15-35).

The START condition begins with the SDA and SCL pins de-asserted. When the SDA pin is sampled high, the baud rate generator is loaded from SSPADD<6:0> and counts down to '0'. If the SCL pin is sampled low while SDA is high, a bus collision occurs, because it is assumed that another master is attempting to drive a data '1' during the START condition.

If the SDA pin is sampled low during this count, the BRG is reset and the SDA line is asserted early (Figure 15-37). If, however, a '1' is sampled on the SDA pin, the SDA pin is asserted low at the end of the BRG count. The baud rate generator is then reloaded and counts down to 0 and during this time, if the SCL pin is sampled as '0', a bus collision does not occur. At the end of the BRG count, the SCL pin is asserted low.

Note: The reason that bus collision is not a factor during a START condition is that no two bus masters can assert a START condition at the exact same time. Therefore, one master will always assert SDA before the other. This condition does not cause a bus collision because the two masters must be allowed to arbitrate the first address following the START condition and if the address is the same, arbitration must be allowed to continue into the data portion, Repeated Start, or Stop conditions.

FIGURE 15-35: BUS COLLISION DURING START CONDITION (SDA ONLY)

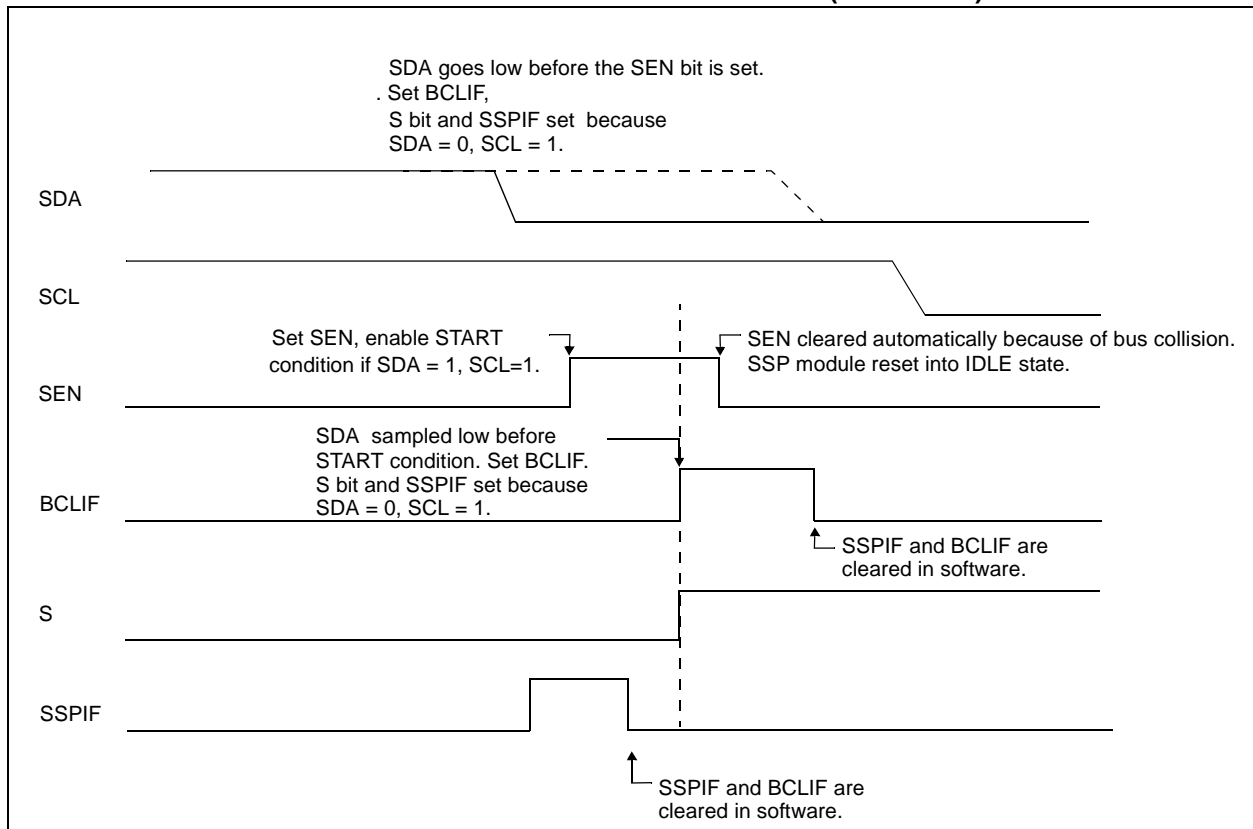

PIC17C7XX

FIGURE 15-36: BUS COLLISION DURING START CONDITION (SCL = 0)

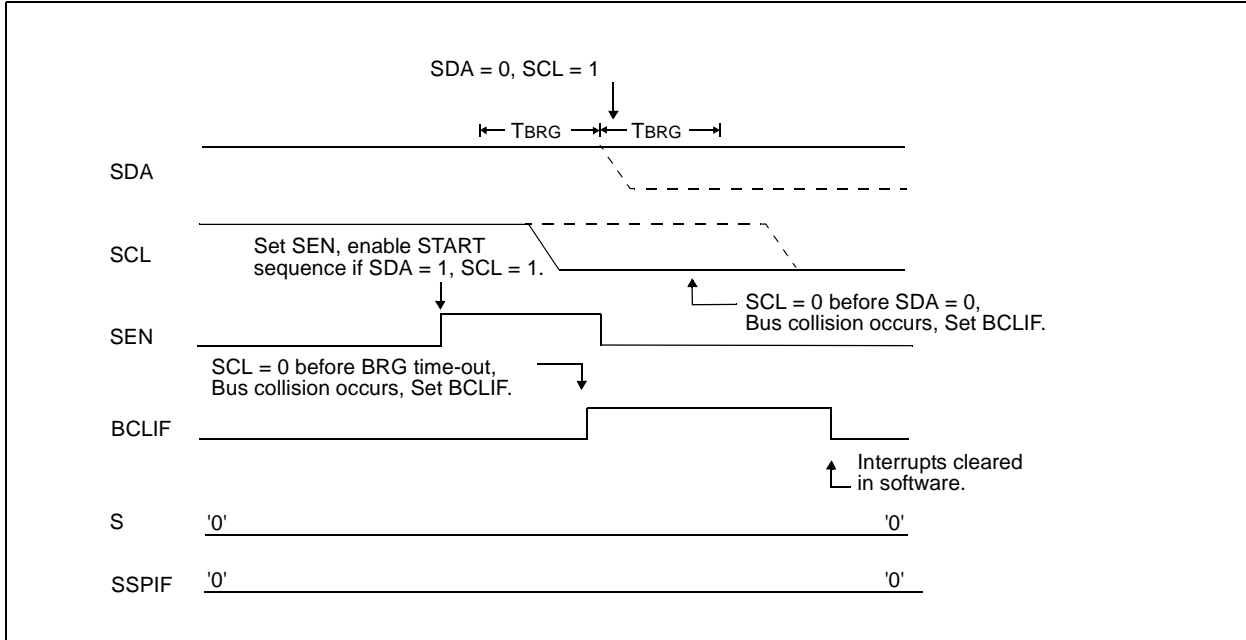
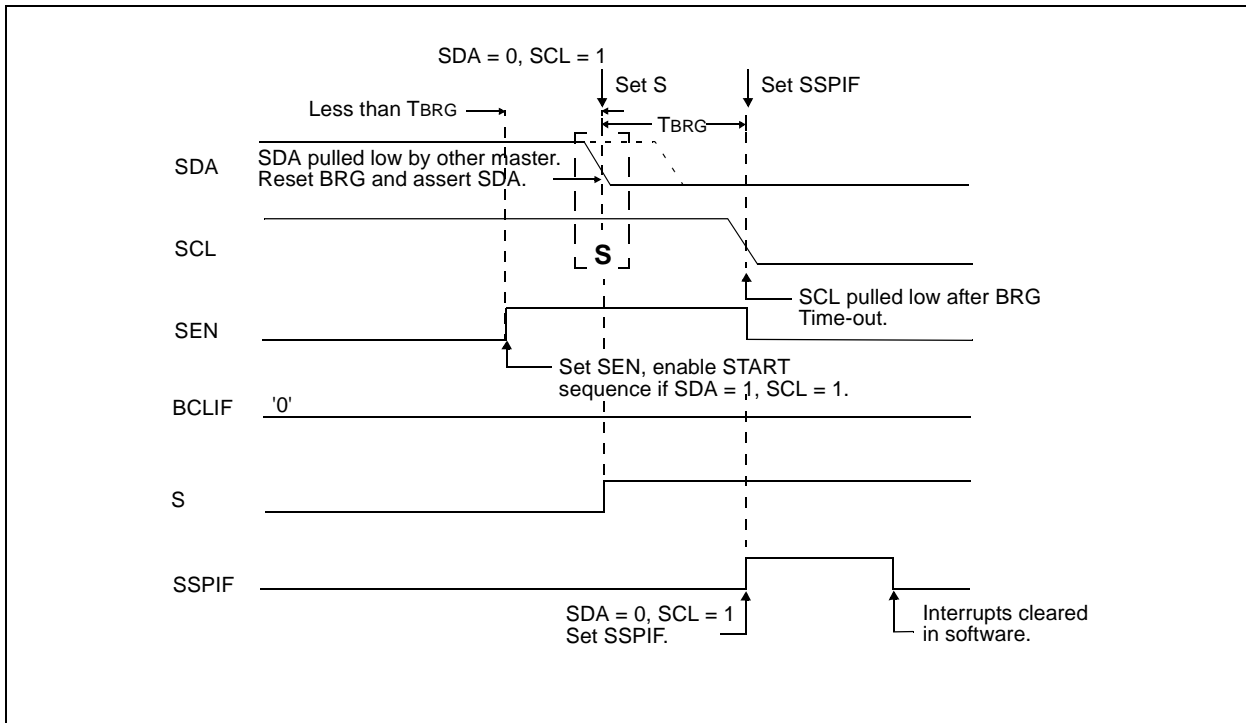

FIGURE 15-37: BRG RESET DUE TO SDA COLLISION DURING START CONDITION



15.2.18.2 Bus Collision During a Repeated Start Condition

During a Repeated Start condition, a bus collision occurs if:

- A low level is sampled on SDA when SCL goes from low level to high level.
- SCL goes low before SDA is asserted low, indicating that another master is attempting to transmit a data '1'.

When the user de-asserts SDA and the pin is allowed to float high, the BRG is loaded with SSPADD<6:0> and counts down to '0'. The SCL pin is then de-asserted and when sampled high, the SDA pin is sampled. If SDA is low, a bus collision has occurred (i.e., another master is attempting to transmit a data '0'). If, however, SDA is sampled high, then the BRG is

reloaded and begins counting. If SDA goes from high to low before the BRG times out, no bus collision occurs because no two masters can assert SDA at exactly the same time.

If, however, SCL goes from high to low before the BRG times out and SDA has not already been asserted, then a bus collision occurs. In this case, another master is attempting to transmit a data '1' during the Repeated Start condition.

If, at the end of the BRG time-out, both SCL and SDA are still high, the SDA pin is driven low, the BRG is reloaded and begins counting. At the end of the count, regardless of the status of the SCL pin, the SCL pin is driven low and the Repeated Start condition is complete (Figure 15-38).

FIGURE 15-38: BUS COLLISION DURING A REPEATED START CONDITION (CASE 1)

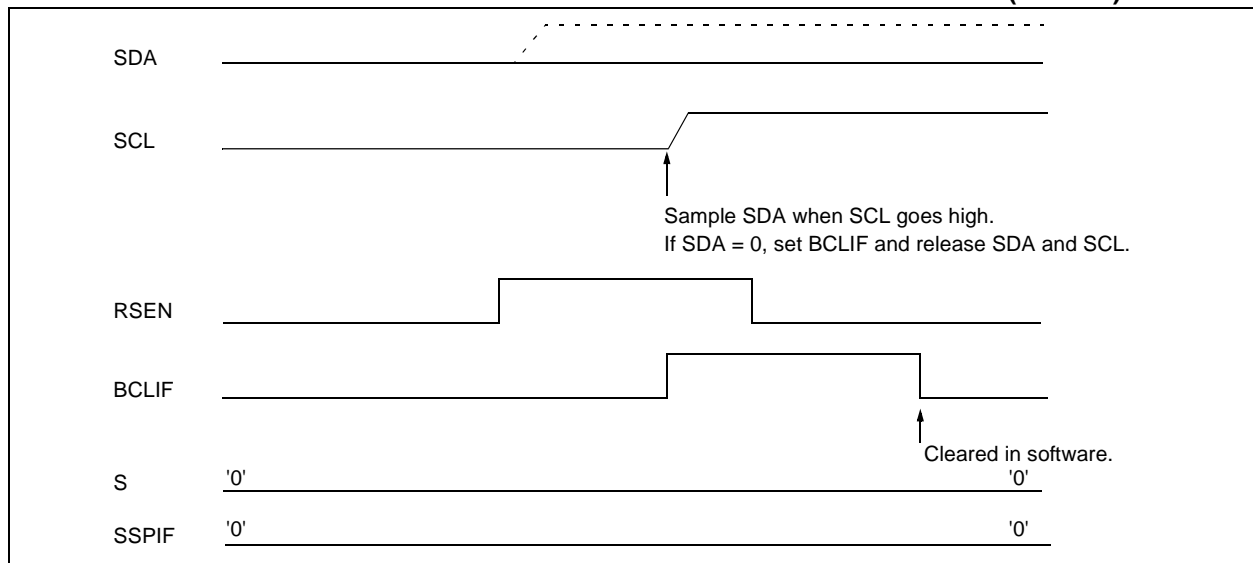
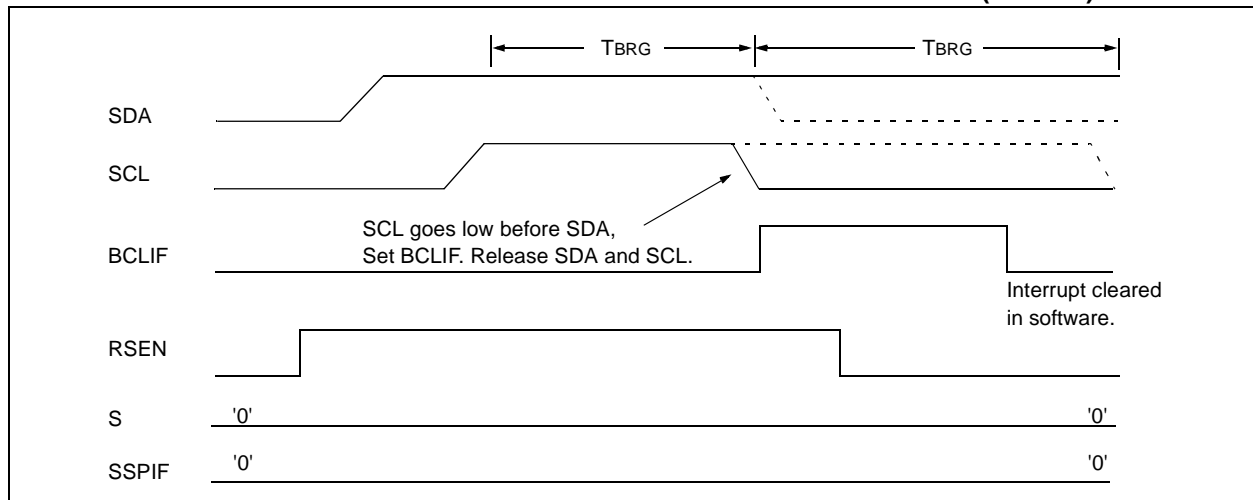

FIGURE 15-39: BUS COLLISION DURING REPEATED START CONDITION (CASE 2)



PIC17C7XX

15.2.18.3 Bus Collision During a STOP Condition

Bus collision occurs during a STOP condition if:

- a) After the SDA pin has been de-asserted and allowed to float high, SDA is sampled low after the BRG has timed out.
- b) After the SCL pin is de-asserted, SCL is sampled low before SDA goes high.

The STOP condition begins with SDA asserted low. When SDA is sampled low, the SCL pin is allowed to float. When the pin is sampled high (clock arbitration), the baud rate generator is loaded with SSPADD<6:0> and counts down to '0'. After the BRG times out, SDA is sampled. If SDA is sampled low, a bus collision has occurred. This is due to another master attempting to drive a data '0'. If the SCL pin is sampled low before SDA is allowed to float high, a bus collision occurs. This is another case of another master attempting to drive a data '0' (Figure 15-40).

FIGURE 15-40: BUS COLLISION DURING A STOP CONDITION (CASE 1)

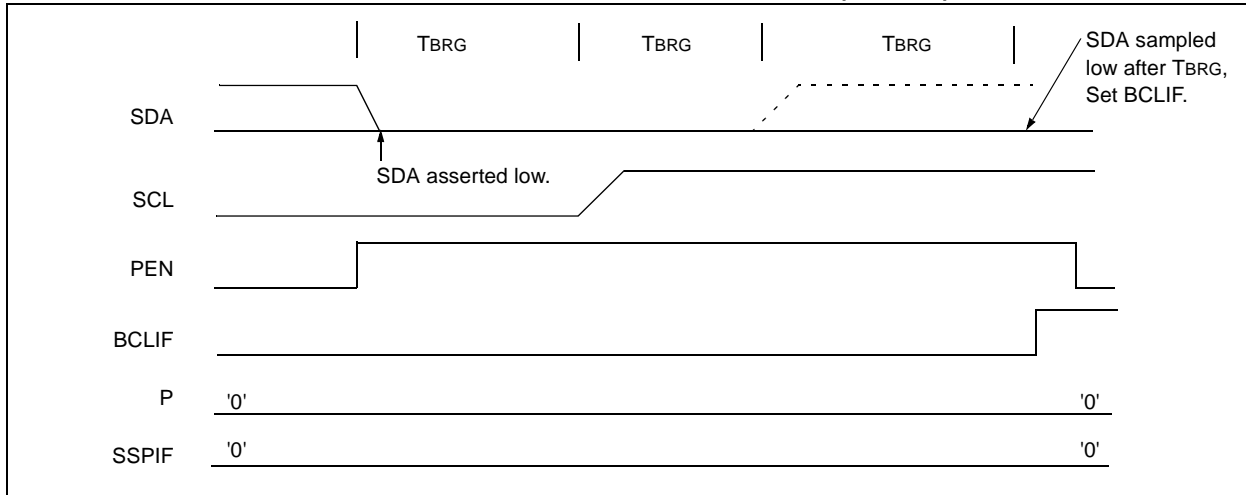
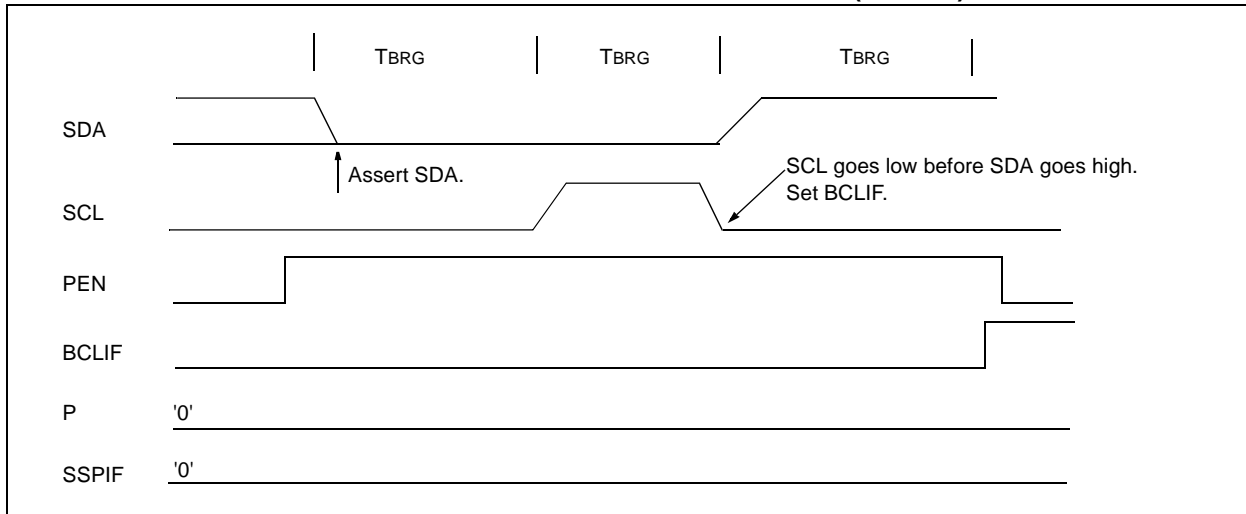

FIGURE 15-41: BUS COLLISION DURING A STOP CONDITION (CASE 2)



15.3 Connection Considerations for I²C Bus

For standard mode I²C bus devices, the values of resistors R_p R_s in Figure 15-42 depends on the following parameters:

- Supply voltage
- Bus capacitance
- Number of connected devices (input current + leakage current)

The supply voltage limits the minimum value of resistor R_p due to the specified minimum sink current of 3 mA at $V_{OL\ max} = 0.4V$ for the specified output stages. For

example, with a supply voltage of $V_{DD} = 5V \pm 10\%$ and $V_{OL\ max} = 0.4V$ at 3 mA, $R_p\ min = (5.5-0.4)/0.003 = 1.7\ k\Omega$. V_{DD} as a function of R_p is shown in Figure 15-42. The desired noise margin of 0.1 V_{DD} for the low level, limits the maximum value of R_s . Series resistors are optional and used to improve ESD susceptibility.

The bus capacitance is the total capacitance of wire, connections and pins. This capacitance limits the maximum value of R_p due to the specified rise time (Figure 15-42).

The SMP bit is the slew rate control enabled bit. This bit is in the SSPSTAT register and controls the slew rate of the I/O pins when in I²C mode (master or slave).

FIGURE 15-42: SAMPLE DEVICE CONFIGURATION FOR I²C BUS

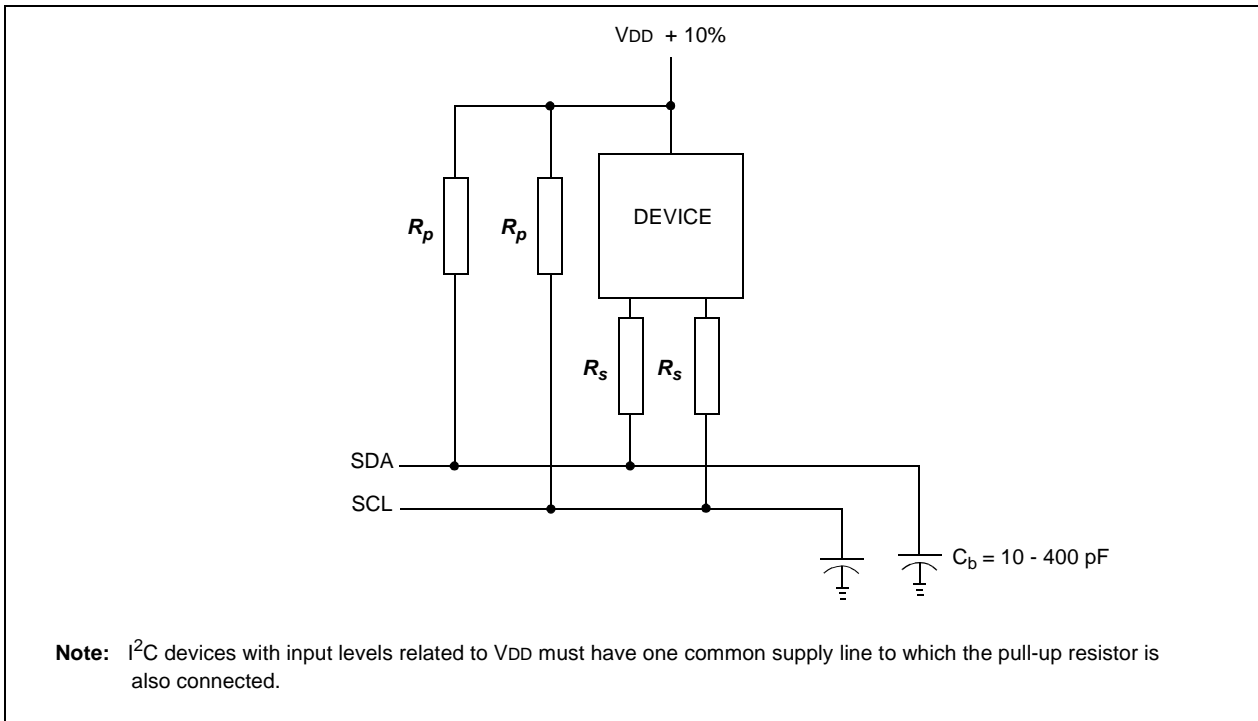

PIC17C7XX

15.4 Example Program

Example 15-2 shows MPLAB® C17 'C' code for using the I²C module in Master mode to communicate with a 24LC01B serial EEPROM. This example uses the PIC® MCU 'C' libraries included with MPLAB C17.

EXAMPLE 15-2: INTERFACING TO A 24LC01B SERIAL EEPROM (USING MPLAB C17)

```
// Include necessary header files
#include <p17c756.h>      // Processor header file
#include <delays.h>      // Delay routines header file
#include <stdlib.h>      // Standard Library header file
#include <i2c16.h>       // I2C routines header file

#define CONTROL 0xa0    // Control byte definition for 24LC01B

// Function declarations
void main(void);
void WritePORTD(static unsigned char data);
void ByteWrite(static unsigned char address,static unsigned char data);
unsigned char ByteRead(static unsigned char address);
void ACKPoll(void);

// Main program
void main(void)
{
    static unsigned char address;    // I2C address of 24LC01B
    static unsigned char data0;     // Data written to 24LC01B
    static unsigned char data1;     // Data read from 24LC01B

    address = 0;                    // Preset address to 0
    OpenI2C(MASTER,SLEW_ON);       // Configure I2C Module Master mode, Slew rate control on
    SSPADD = 39;                    // Configure clock for 100KHz

    while(address<128)              // Loop 128 times, 24LC01B is 128x8
    {
        data0 = PORTB;
        do
        {
            ByteWrite(address,data0); // Write data to EEPROM
            ACKPoll();                // Poll the 24LC01B for state
            data1 = ByteRead(address); // Read data from EEPROM into SSPBUF
        } while(data1 != data0);      // Loop as long as data not correctly
                                        // written to 24LC01B

        address++;                    // Increment address
    }
    while(1)                          // Done writing 128 bytes to 24LC01B, Loop forever
    {
        Nop();
    }
}
```

EXAMPLE 15-2: INTERFACING TO A 24LC01B SERIAL EEPROM (USING MPLAB C17)

```

// Writes the byte data to 24LC01B at the specified address
void ByteWrite(static unsigned char address, static unsigned char data)
{
    StartI2C();           // Send start bit
    IdleI2C();           // Wait for idle condition
    WriteI2C(CONTROL);   // Send control byte
    IdleI2C();           // Wait for idle condition
    if (!SSPCON2bits.ACKSTAT) // If 24LC01B ACKs
    {
        WriteI2C(address); // Send control byte
        IdleI2C();         // Wait for idle condition

        if (!SSPCON2bits.ACKSTAT) // If 24LC01B ACKs
            WriteI2C(data);      // Send data
    }
    IdleI2C();           // Wait for idle condition
    StopI2C();          // Send stop bit
    IdleI2C();           // Wait for idle condition
    return;
}

// Reads a byte of data from 24LC01B at the specified address
unsigned char ByteRead(static unsigned char address)
{
    StartI2C();           // Send start bit
    IdleI2C();           // Wait for idle condition
    WriteI2C(CONTROL);   // Send control byte
    IdleI2C();           // Wait for idle condition
    if (!SSPCON2bits.ACKSTAT) // If the 24LC01B ACKs
    {
        WriteI2C(address); // Send address
        IdleI2C();         // Wait for idle condition
        if (!SSPCON2bits.ACKSTAT) // If the 24LC01B ACKs
        {
            RestartI2C(); // Send restart
            IdleI2C();    // Wait for idle condition
            WriteI2C(CONTROL+1); // Send control byte with R/W set
            IdleI2C();    // Wait for idle condition
            if (!SSPCON2bits.ACKSTAT) // If the 24LC01B ACKs
            {
                getcI2C(); // Read a byte of data from 24LC01B
                IdleI2C(); // Wait for idle condition
                NotAckI2C(); // Send a NACK to 24LC01B
                IdleI2C(); // Wait for idle condition
                StopI2C(); // Send stop bit
                IdleI2C(); // Wait for idle condition
            }
        }
    }
    return(SSPBUF);
}

```

PIC17C7XX

EXAMPLE 15-2: INTERFACING TO A 24LC01B SERIAL EEPROM (USING MPLAB C17)

```
void ACKPoll(void)
{
    StartI2C();           // Send start bit
    IdleI2C();           // Wait for idle condition
    WriteI2C(CONTROL);   // Send control byte
    IdleI2C();           // Wait for idle condition
    // Poll the ACK bit coming from the 24LC01B
    // Loop as long as the 24LC01B NACKs
    while (SSPCON2bits.ACKSTAT)
    {
        RestartI2C();    // Send a restart bit
        IdleI2C();       // Wait for idle condition
        WriteI2C(CONTROL); // Send control byte
        IdleI2C();       // Wait for idle condition
    }
    IdleI2C();           // Wait for idle condition
    StopI2C();          // Send stop bit
    IdleI2C();           // Wait for idle condition
    return;
}
```

16.0 ANALOG-TO-DIGITAL CONVERTER (A/D) MODULE

The analog-to-digital (A/D) converter module has twelve analog inputs for the PIC17C75X devices and sixteen for the PIC17C76X devices.

The analog input charges a sample and hold capacitor. The output of the sample and hold capacitor is the input into the converter. The converter then generates a digital result of this analog level via successive approximation. This A/D conversion of the analog input signal, results in a corresponding 10-bit digital number.

The analog reference voltages (positive and negative supply) are software selectable to either the device's supply voltages (AVDD, AVSS), or the voltage level on the RG3/AN0/VREF+ and RG2/AN1/VREF- pins.

The A/D converter has a unique feature of being able to operate while the device is in SLEEP mode. To operate in SLEEP, the A/D clock must be derived from the A/D's internal RC oscillator.

The A/D module has four registers. These registers are:

- A/D Result High Register (ADRESH)
- A/D Result Low Register (ADRESL)
- A/D Control Register0 (ADCON0)
- A/D Control Register1 (ADCON1)

The ADCON0 register, shown in Register 16-1, controls the operation of the A/D module. The ADCON1 register, shown in Register 16-2, configures the functions of the port pins. The port pins can be configured as analog inputs (RG3 and RG2 can also be the voltage references), or as digital I/O.

REGISTER 16-1: ADCON0 REGISTER (ADDRESS: 14h, BANK 5)

R/W-0	R/W-0	R/W-0	R/W-0	U-0	R/W-0	U-0	R/W-0
CHS3	CHS2	CHS1	CHS0	—	GO/DONE	—	ADON
bit 7							bit 0

- bit 7-4 **CHS3:CHS0:** Analog Channel Select bits
 0000 = channel 0, (AN0)
 0001 = channel 1, (AN1)
 0010 = channel 2, (AN2)
 0011 = channel 3, (AN3)
 0100 = channel 4, (AN4)
 0101 = channel 5, (AN5)
 0110 = channel 6, (AN6)
 0111 = channel 7, (AN7)
 1000 = channel 8, (AN8)
 1001 = channel 9, (AN9)
 1010 = channel 10, (AN10)
 1011 = channel 11, (AN11)
 1100 = channel 12, (AN12) (PIC17C76X only)
 1101 = channel 13, (AN13) (PIC17C76X only)
 1110 = channel 14, (AN14) (PIC17C76X only)
 1111 = channel 15, (AN15) (PIC17C76X only)
 11xx = **RESERVED**, do not select (PIC17C75X only)
- bit 3 **Unimplemented:** Read as '0'
- bit 2 **GO/DONE:** A/D Conversion Status bit
If ADON = 1:
 1 = A/D conversion in progress (setting this bit starts the A/D conversion, which is automatically cleared by hardware when the A/D conversion is complete)
 0 = A/D conversion not in progress
- bit 1 **Unimplemented:** Read as '0'
- bit 0 **ADON:** A/D On bit
 1 = A/D converter module is operating
 0 = A/D converter module is shut-off and consumes no operating current

Legend:			
R = Readable bit	W = Writable bit	U = Unimplemented bit, read as '0'	
- n = Value at POR Reset	'1' = Bit is set	'0' = Bit is cleared	x = Bit is unknown

PIC17C7XX

REGISTER 16-2: ADCON1 REGISTER (ADDRESS 15h, BANK 5)

R/W-0	R/W-0	R/W-0	U-0	R/W-0	R/W-0	R/W-0	R/W-0
ADCS1	ADCS0	ADFM	—	PCFG3	PCFG2	PCFG1	PCFG0
bit 7							bit 0

bit 7-6 **ADCS1:ADCS0:** A/D Conversion Clock Select bits

00 = FOSC/8

01 = FOSC/32

10 = FOSC/64

11 = FRC (clock derived from an internal RC oscillator)

bit 5 **ADFM:** A/D Result Format Select

1 = Right justified. 6 Most Significant bits of ADRESH are read as '0'.

0 = Left justified. 6 Least Significant bits of ADRESL are read as '0'.

bit 4 **Unimplemented:** Read as '0'

bit 3-1 **PCFG3:PCFG1:** A/D Port Configuration Control bits

bit 0 **PCFG0:** A/D Voltage Reference Select bit

1 = A/D reference is the VREF+ and VREF- pins

0 = A/D reference is AVDD and AVSS

Note: When this bit is set, ensure that the A/D voltage reference specifications are met.

PCFG3:PCFG0	AN15	AN14	AN13	AN12	AN11	AN10	AN9	AN8	AN7	AN6	AN5	AN4	AN3	AN2	AN1	AN0
000x	A	A	A	A	A	A	A	A	A	A	A	A	A	A	A	A
001x	D	A	A	A	A	A	A	A	D	A	A	A	A	A	A	A
010x	D	D	A	A	A	A	A	A	D	D	A	A	A	A	A	A
011x	D	D	D	A	A	A	A	A	D	D	D	A	A	A	A	A
100x	D	D	D	D	A	A	A	A	D	D	D	D	A	A	A	A
101x	D	D	D	D	D	A	A	A	D	D	D	D	D	A	A	A
110x	D	D	D	D	D	D	A	A	D	D	D	D	D	D	A	A
111x	D	D	D	D	D	D	D	D	D	D	D	D	D	D	D	D

A = Analog input

D = Digital I/O

Legend:

R = Readable bit

W = Writable bit

U = Unimplemented bit, read as '0'

- n = Value at POR Reset

'1' = Bit is set

'0' = Bit is cleared

x = Bit is unknown

The ADRESH:ADRESL registers contain the 10-bit result of the A/D conversion. When the A/D conversion is complete, the result is loaded into this A/D result register pair, the GO/DONE bit (ADCON0<2>) is cleared and A/D interrupt flag bit, ADIF is set. The block diagrams of the A/D module are shown in Figure 16-1.

After the A/D module has been configured as desired, the selected channel must be acquired before the conversion is started. The analog input channels must have their corresponding DDR bits selected as inputs. To determine sample time, see Section 16.1. After this acquisition time has elapsed, the A/D conversion can be started. The following steps should be followed for doing an A/D conversion:

1. Configure the A/D module:
 - a) Configure analog pins/voltage reference/ and digital I/O (ADCON1)
 - b) Select A/D input channel (ADCON0)
 - c) Select A/D conversion clock (ADCON0)
 - d) Turn on A/D module (ADCON0)
2. Configure A/D interrupt (if desired):
 - a) Clear ADIF bit
 - b) Set ADIE bit
 - c) Clear GLINTD bit
3. Wait the required acquisition time.
4. Start conversion:
 - a) Set GO/DONE bit (ADCON0)
5. Wait for A/D conversion to complete, by either:
 - a) Polling for the GO/DONE bit to be cleared
 - OR
 - b) Waiting for the A/D interrupt
6. Read A/D Result register pair (ADRESH:ADRESL), clear bit ADIF, if required.
7. For next conversion, go to step 1 or step 2, as required. The A/D conversion time per bit is defined as TAD. A minimum wait of 2TAD is required before next acquisition starts.

FIGURE 16-1: A/D BLOCK DIAGRAM

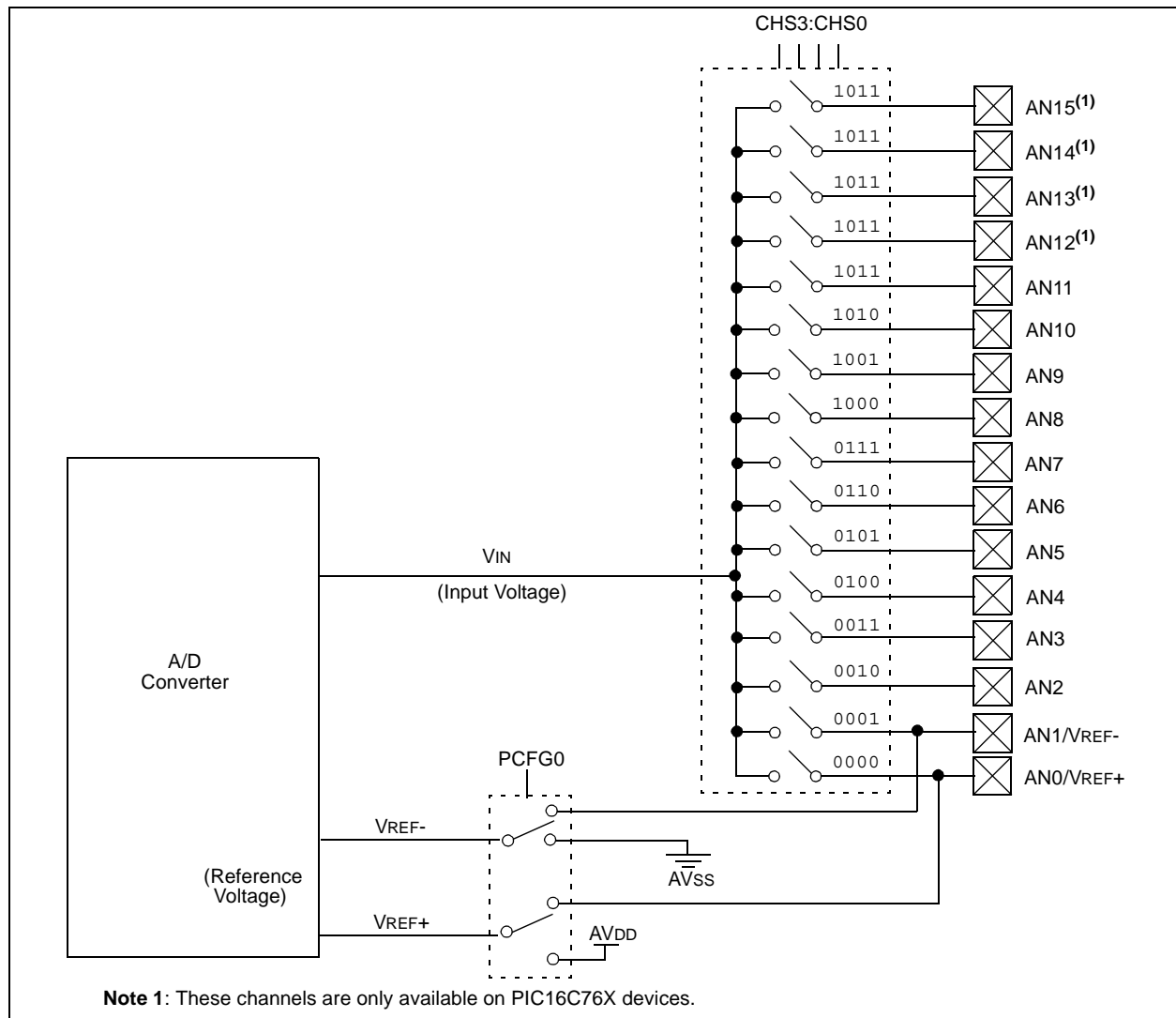

PIC17C7XX

Figure 16-2 shows the conversion sequence and the terms that are used. Acquisition time is the time that the A/D module's holding capacitor is connected to the external voltage level. Then, there is the conversion time of 12 TAD, which is started when the GO bit is set. The sum of these two times is the sampling time. There is a minimum acquisition time to ensure that the holding capacitor is charged to a level that will give the desired accuracy for the A/D conversion.

FIGURE 16-2: A/D CONVERSION SEQUENCE

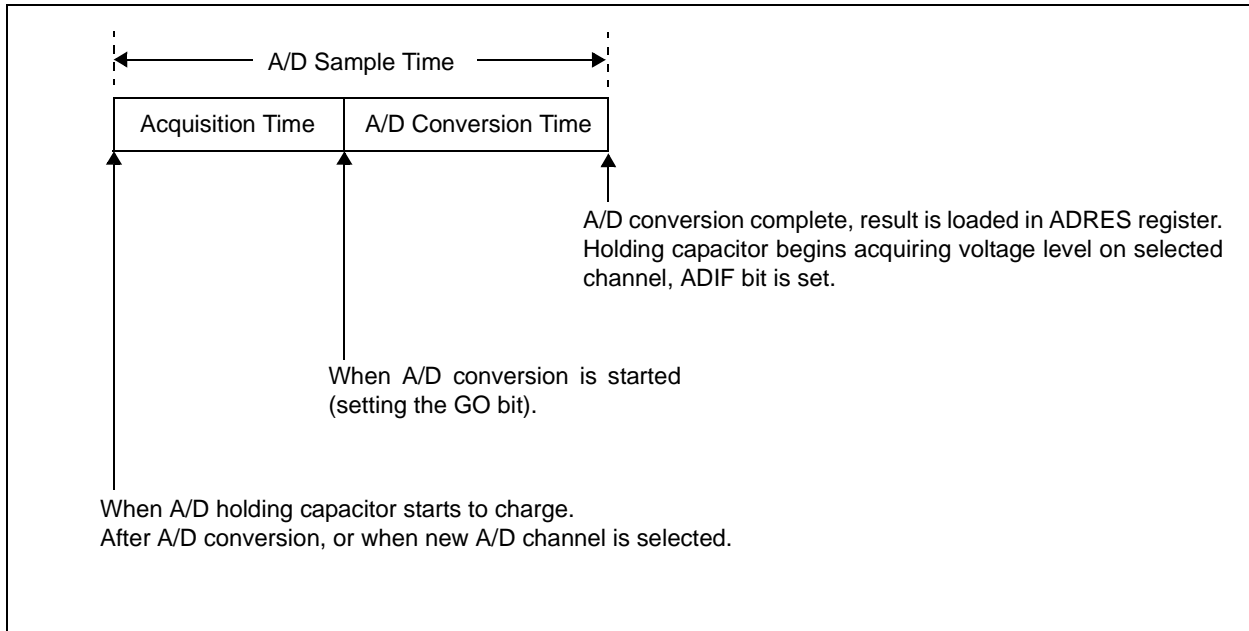

16.1 A/D Acquisition Requirements

For the A/D converter to meet its specified accuracy, the charge holding capacitor (CHOLD) must be allowed to fully charge to the input channel voltage level. The analog input model is shown in Figure 16-3. The source impedance (Rs) and the internal sampling switch (Rss) impedance directly affect the time required to charge the capacitor CHOLD. The sampling switch (Rss) impedance varies over the device voltage (VDD), Figure 16-3. **The maximum recommended impedance for analog sources is 10 kΩ.** As the impedance is decreased, the acquisition time may be decreased. After the analog input channel is selected (changed) this acquisition must be done before the conversion can be started.

To calculate the minimum acquisition time, Equation 16-1 may be used. This equation assumes that 1/2 LSB error is used (1024 steps for the A/D). The 1/2 LSB error is the maximum error allowed for the A/D to meet its specified resolution.

Example 16-1 shows the calculation of the minimum required acquisition time (TACQ). This is based on the following application system assumptions.

CHOLD	=	120 pF
Rs	=	10 kΩ
Conversion Error	≤	1/2 LSB
VDD	=	5V → Rss = 7 kΩ (see graph in Figure 16-3)
Temperature	=	50°C (system max.)
VHOLD	=	0V @ time = 0

EQUATION 16-1: ACQUISITION TIME

$$\begin{aligned} T_{ACQ} &= \text{Amplifier Settling Time} + \\ &\quad \text{Holding Capacitor Charging Time} + \\ &\quad \text{Temperature Coefficient} \\ &= T_{AMP} + T_C + T_{COFF} \end{aligned}$$

EQUATION 16-2: A/D MINIMUM CHARGING TIME

$$\begin{aligned} V_{HOLD} &= (V_{REF} - (V_{REF}/2048)) \cdot (1 - e^{-(T_c/CHOLD)(R_{IC} + R_{SS} + R_s)}) \\ \text{or} \\ T_C &= -(120 \text{ pF})(1 \text{ k}\Omega + R_{SS} + R_s) \ln(1/2047) \end{aligned}$$

EXAMPLE 16-1: CALCULATING THE MINIMUM REQUIRED ACQUISITION TIME

$$\begin{aligned} T_{ACQ} &= T_{AMP} + T_C + T_{COFF} \\ \text{Temperature coefficient is only required for temperatures } > 25^\circ\text{C.} \\ T_{ACQ} &= 2 \mu\text{s} + T_c + [(Temp - 25^\circ\text{C})(0.05 \mu\text{s}/^\circ\text{C})] \\ T_C &= -CHOLD (R_{IC} + R_{SS} + R_s) \ln(1/2047) \\ &= -120 \text{ pF} (1 \text{ k}\Omega + 7 \text{ k}\Omega + 10 \text{ k}\Omega) \ln(0.0004885) \\ &= -120 \text{ pF} (18 \text{ k}\Omega) \ln(0.0004885) \\ &= -2.16 \mu\text{s} (-7.6241) \\ &= 16.47 \mu\text{s} \\ T_{ACQ} &= 2 \mu\text{s} + 16.47 \mu\text{s} + [(50^\circ\text{C} - 25^\circ\text{C})(0.05 \mu\text{s}/^\circ\text{C})] \\ &= 18.447 \mu\text{s} + 1.25 \mu\text{s} \\ &= 19.72 \mu\text{s} \end{aligned}$$

- Note 1:** The reference voltage (VREF) has no effect on the equation since it cancels itself out.
- 2:** The charge holding capacitor (CHOLD) is not discharged after each conversion.
- 3:** The maximum recommended impedance for analog sources is 10 kΩ. This is required to meet the pin leakage specification.
- 4:** After a conversion has completed, a 2.0 TAD delay must complete before acquisition can begin again. During this time, the holding capacitor is not connected to the selected A/D input channel.

PIC17C7XX

FIGURE 16-3: ANALOG INPUT MODEL

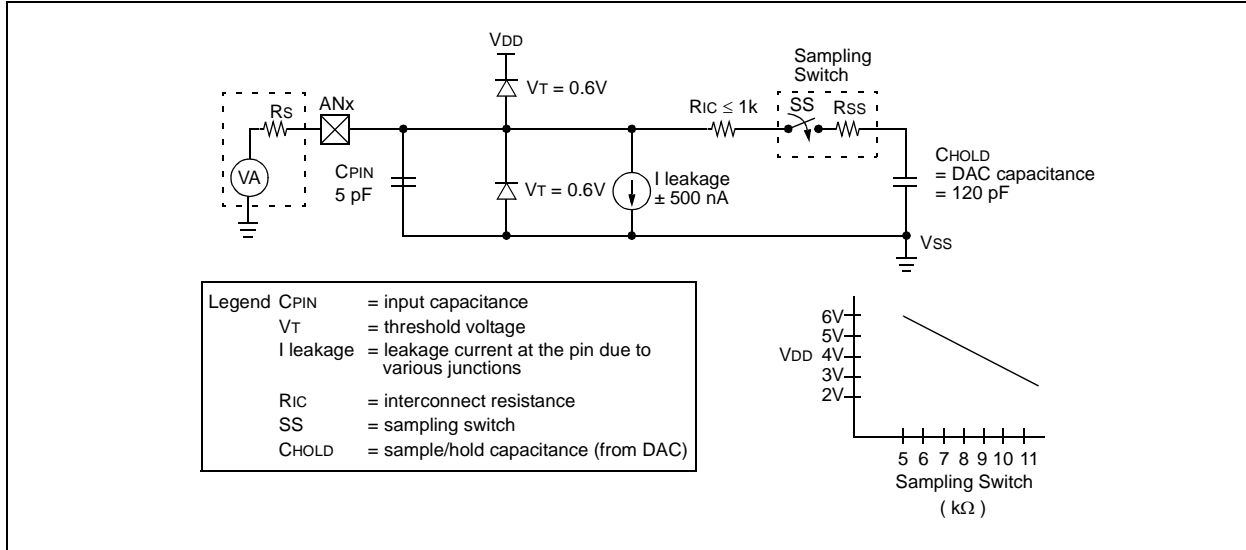

16.2 Selecting the A/D Conversion Clock

The A/D conversion time per bit is defined as TAD. The A/D conversion requires a minimum 12TAD per 10-bit conversion. The source of the A/D conversion clock is software selected. The four possible options for TAD are:

- 8TOSC
- 32TOSC
- 64TOSC
- Internal RC oscillator

For correct A/D conversions, the A/D conversion clock (TAD) must be selected to ensure a minimum TAD time of 1.6 μ s.

Table 16-1 and Table 16-2 show the resultant TAD times derived from the device operating frequencies and the A/D clock source selected. These times are for standard voltage range devices.

TABLE 16-1: TAD vs. DEVICE OPERATING FREQUENCIES (STANDARD DEVICES (C))

AD Clock Source (TAD)		Max Fosc (MHz)
Operation	ADCS1:ADCS0	
8TOSC	00	5
32TOSC	01	20
64TOSC	10	33
RC	11	—

Note: When the device frequency is greater than 1 MHz, the RC A/D conversion clock source is only recommended for SLEEP operation.

TABLE 16-2: TAD vs. DEVICE OPERATING FREQUENCIES (EXTENDED VOLTAGE DEVICES (LC))

AD Clock Source (TAD)		Max Fosc (MHz)
Operation	ADCS1:ADCS0	
8TOSC	00	2.67
32TOSC	01	10.67
64TOSC	10	21.33
RC	11	—

Note: When the device frequency is greater than 1 MHz, the RC A/D conversion clock source is only recommended for SLEEP operation.

PIC17C7XX

16.3 Configuring Analog Port Pins

The ADCON1, and DDR registers control the operation of the A/D port pins. The port pins that are desired as analog inputs must have their corresponding DDR bits set (input). If the DDR bit is cleared (output), the digital output level (VOH or VOL) will be converted.

The A/D operation is independent of the state of the CHS2:CHS0 bits and the DDR bits.

- Note 1:** When reading the port register, any pin configured as an analog input channel will read as cleared (a low level). Pins configured as digital inputs, will convert an analog input. Analog levels on a digitally configured input will not affect the conversion accuracy.
- 2:** Analog levels on any pin that is defined as a digital input (including the AN15:AN0 pins), may cause the input buffer to consume current that is out of the devices specification.

16.4 A/D Conversions

Example 16-2 shows how to perform an A/D conversion. The PORTF and lower four PORTG pins are configured as analog inputs. The analog references (VREF+ and VREF-) are the device AVDD and AVSS. The A/D interrupt is enabled, and the A/D conversion clock is FRC. The conversion is performed on the RG3/AN0 pin (channel 0).

- Note:** The GO/DONE bit should **NOT** be set in the same instruction that turns on the A/D.

Clearing the GO/DONE bit during a conversion will abort the current conversion. The A/D result register pair will NOT be updated with the partially completed A/D conversion sample. That is, the ADRESH:ADRESL registers will continue to contain the value of the last completed conversion (or the last value written to the ADRESH:ADRESL registers). After the A/D conversion is aborted, a 2TAD wait is required before the next acquisition is started. After this 2TAD wait, acquisition on the selected channel is automatically started.

In Figure 16-4, after the GO bit is set, the first time segment has a minimum of TCY and a maximum of TAD.

EXAMPLE 16-2: A/D CONVERSION

```

MOVLB 5 ; Bank 5
CLRF ADCON1, F ; Configure A/D inputs, All analog, TAD = Fosc/8, left just.
MOVLW 0x01 ; A/D is on, Channel 0 is selected
MOVWF ADCON0 ;
MOVLB 4 ; Bank 4
BCF PIR2, ADIF ; Clear A/D interrupt flag bit
BSF PIE2, ADIE ; Enable A/D interrupts
BSF INTSTA, PEIE ; Enable peripheral interrupts
BCF CPUSTA, GLINTD ; Enable all interrupts
;
; Ensure that the required sampling time for the selected input channel has elapsed.
; Then the conversion may be started.
;
MOVLB 5 ; Bank 5
BSF ADCON0, GO ; Start A/D Conversion
: ; The ADIF bit will be set and the GO/DONE bit
: ; is cleared upon completion of the A/D Conversion
    
```

FIGURE 16-4: A/D CONVERSION TAD CYCLES

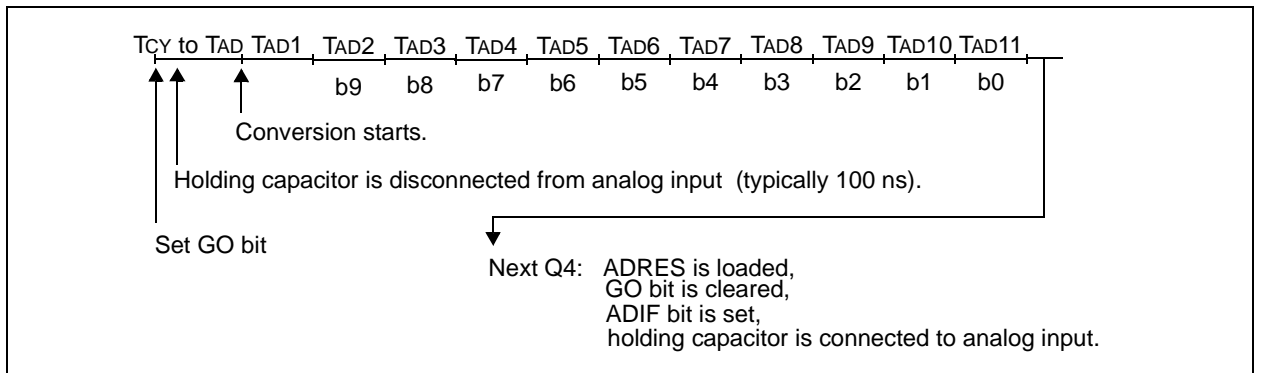
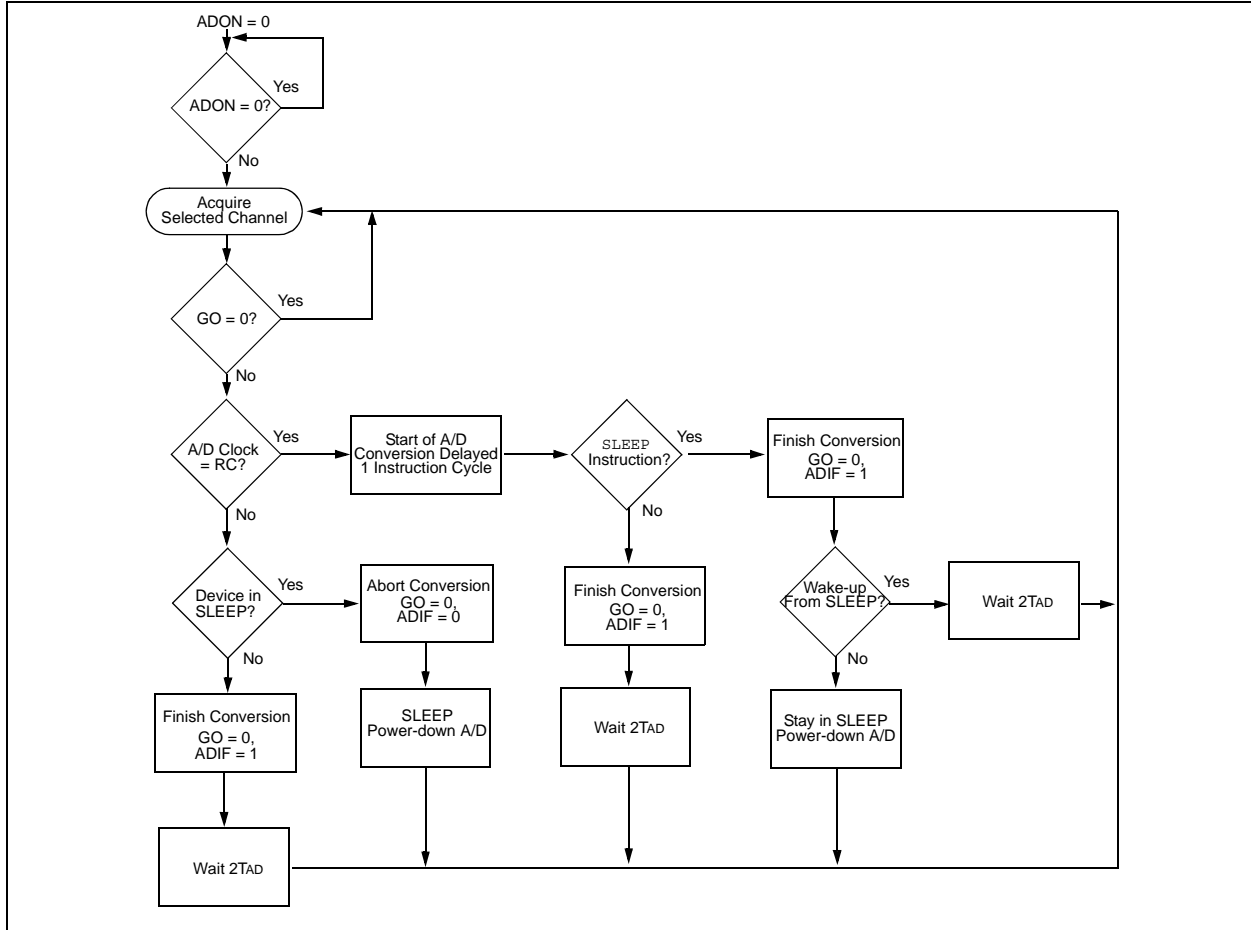

FIGURE 16-5: FLOW CHART OF A/D OPERATION



PIC17C7XX

16.4.1 A/D RESULT REGISTERS

The ADRESH:ADRESL register pair is the location where the 10-bit A/D result is loaded at the completion of the A/D conversion. This register pair is 16-bits wide. The A/D module gives the flexibility to left or right justify the 10-bit result in the 16-bit result register. The A/D Format Select bit (ADFM) controls this justification. Figure 16-6 shows the operation of the A/D result justification. The extra bits are loaded with '0's'. When an A/D result will not overwrite these locations (A/D disable), these registers may be used as two general purpose 8-bit registers.

16.5 A/D Operation During SLEEP

The A/D module can operate during SLEEP mode. This requires that the A/D clock source be set to RC (ADCS1:ADCS0 = 11). When the RC clock source is selected, the A/D module waits one instruction cycle before starting the conversion. This allows the SLEEP instruction to be executed, which eliminates all digital switching noise from the conversion. When the conversion is completed, the GO/DONE bit will be cleared, and the result loaded into the ADRES register. If the A/D interrupt is enabled, the device will wake-up from

SLEEP. If the A/D interrupt is not enabled, the A/D module will then be turned off, although the ADON bit will remain set.

When the A/D clock source is another clock option (not RC), a SLEEP instruction will cause the present conversion to be aborted and the A/D module to be turned off, though the ADON bit will remain set.

Turning off the A/D places the A/D module in its lowest current consumption state.

Note: For the A/D module to operate in SLEEP, the A/D clock source must be set to RC (ADCS1:ADCS0 = 11). To allow the conversion to occur during SLEEP, ensure the SLEEP instruction immediately follows the instruction that sets the GO/DONE bit.

16.6 Effects of a RESET

A device RESET forces all registers to their RESET state. This forces the A/D module to be turned off, and any conversion is aborted.

The value that is in the ADRESH:ADRESL registers is not modified for a Power-on Reset. The ADRESH:ADRESL registers will contain unknown data after a Power-on Reset.

FIGURE 16-6: A/D RESULT JUSTIFICATION

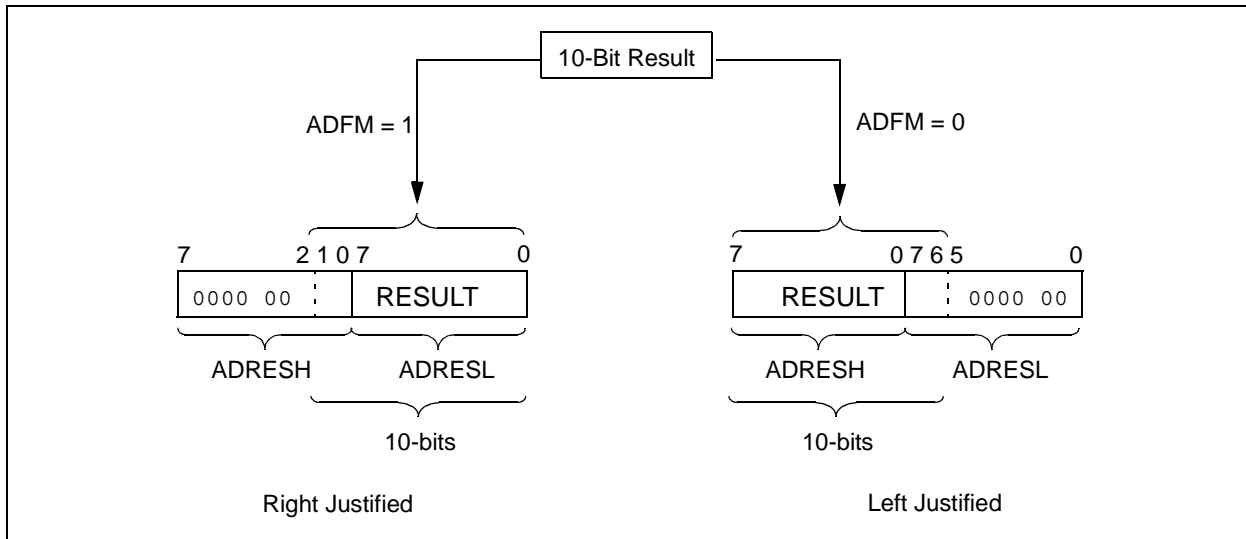

16.7 A/D Accuracy/Error

In systems where the device frequency is low, use of the A/D RC clock is preferred. At moderate to high frequencies, T_{AD} should be derived from the device oscillator.

The absolute accuracy specified for the A/D converter includes the sum of all contributions for quantization error, integral error, differential error, full scale error, offset error, and monotonicity. It is defined as the maximum deviation from an actual transition versus an ideal transition for any code. The absolute error of the A/D converter is specified at $< \pm 1$ LSB for $V_{DD} = V_{REF}$ (over the device's specified operating range). However, the accuracy of the A/D converter will degrade as V_{REF} diverges from V_{DD} .

For a given range of analog inputs, the output digital code will be the same. This is due to the quantization of the analog input to a digital code. Quantization error is typically $\pm 1/2$ LSB and is inherent in the analog to digital conversion process. The only way to reduce quantization error is to increase the resolution of the A/D converter or oversample.

Offset error measures the first actual transition of a code versus the first ideal transition of a code. Offset error shifts the entire transfer function. Offset error can be calibrated out of a system or introduced into a system through the interaction of the total leakage current and source impedance at the analog input.

Gain error measures the maximum deviation of the last actual transition and the last ideal transition adjusted for offset error. This error appears as a change in slope of the transfer function. The difference in gain error to full scale error is that full scale does not take offset error into account. Gain error can be calibrated out in software.

Linearity error refers to the uniformity of the code changes. Linearity errors cannot be calibrated out of the system. Integral non-linearity error measures the actual code transition versus the ideal code transition, adjusted by the gain error for each code.

Differential non-linearity measures the maximum actual code width versus the ideal code width. This measure is unadjusted.

The maximum pin leakage current is specified in the Device Data Sheet electrical specification (Table 20-2, parameter #D060).

In systems where the device frequency is low, use of the A/D RC clock is preferred. At moderate to high frequencies, T_{AD} should be derived from the device oscillator. T_{AD} must not violate the minimum and should be minimized to reduce inaccuracies due to noise and sampling capacitor bleed off.

In systems where the device will enter SLEEP mode after the start of the A/D conversion, the RC clock source selection is required. In this mode, the digital noise from the modules in SLEEP are stopped. This method gives high accuracy.

16.8 Connection Considerations

If the input voltage exceeds the rail values (V_{SS} or V_{DD}) by greater than 0.3V, then the accuracy of the conversion is out of specification.

An external RC filter is sometimes added for anti-aliasing of the input signal. The R component should be selected to ensure that the total source impedance is kept under the 10 k Ω recommended specification. Any external components connected (via hi-impedance) to an analog input pin (capacitor, zener diode, etc.) should have very little leakage current at the pin.

16.9 Transfer Function

The transfer function of the A/D converter is as follows: the first transition occurs when the analog input voltage (V_{AIN}) equals Analog $V_{REF} / 1024$ (Figure 16-7).

FIGURE 16-7: A/D TRANSFER FUNCTION

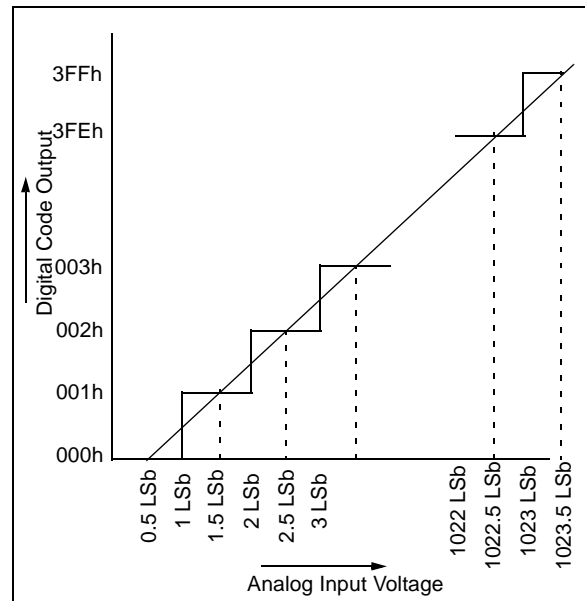

PIC17C7XX

16.10 References

A good reference for understanding A/D converter is the "Analog-Digital Conversion Handbook" third edition, published by Prentice Hall (ISBN 0-13-03-2848-0).

TABLE 16-3: REGISTERS/BITS ASSOCIATED WITH A/D

Address	Name	Bit 7	Bit 6	Bit 5	Bit 4	Bit 3	Bit 2	Bit 1	Bit 0	POR, BOR	MCLR, WDT
06h, unbanked	CPUSTA	—	—	STAKAV	GLINTD	\overline{TO}	\overline{PD}	\overline{POR}	\overline{BOR}	--11 1100	--11 qq11
07h, unbanked	INTSTA	PEIF	T0CKIF	T0IF	INTF	PEIE	T0CKIE	T0IE	INTE	0000 0000	0000 0000
10h, Bank 4	PIR2	SSPIF	BCLIF	ADIF	—	CA4IF	CA3IF	TX2IF	RC2IF	000- 0010	000- 0010
11h, Bank 4	PIE2	SSPIE	BCLIE	ADIE	—	CA4IE	CA3IE	TX2IE	RC2IE	000- 0000	000- 0000
10h, Bank 5	DDRF	Data Direction Register for PORTF								1111 1111	1111 1111
11h, Bank 5	PORTF	RF7/ AN11	RF6/ AN10	RF5/ AN9	RF4/ AN8	RF3/ AN7	RF2/ AN6	RF1/ AN5	RF0/ AN4	0000 0000	0000 0000
12h, Bank 5	DDRG	Data Direction register for PORTG								1111 1111	1111 1111
13h, Bank 5	PORTG	RG7/ TX2/CK2	RG6/ RX2/DT2	RG5/ PWM3	RG4/ CAP3	RG3/ AN0/VREF+	RG2/ AN1/VREF-	RG1/ AN2	RG0/ AN3	xxxx 0000	uuuu 0000
14h, Bank 5	ADCON0	CHS3	CHS2	CHS1	CHS0	—	GO/DONE	—	ADON	0000 -0-0	0000 -0-0
15h, Bank 5	ADCON1	ADCS1	ADCS0	ADFM	—	PCFG3	PCFG2	PCFG1	PCFG0	000- 0000	000- 0000
16h, Bank 5	ADRESL	A/D Result Low Register								xxxx xxxx	uuuu uuuu
17h, Bank 5	ADRESH	A/D Result High Register								xxxx xxxx	uuuu uuuu

Legend: x = unknown, u = unchanged, - = unimplemented, read as '0'. Shaded cells are not used for A/D conversion.

Note: Other (non power-up) RESETS include: external RESET through \overline{MCLR} and Watchdog Timer Reset.

17.0 SPECIAL FEATURES OF THE CPU

What sets a microcontroller apart from other processors are special circuits to deal with the needs of real-time applications. The PIC17CXXX family has a host of such features intended to maximize system reliability, minimize cost through elimination of external components, provide power saving operating modes and offer code protection. These are:

- Oscillator Selection (Section 4.0)
- RESET (Section 5.0)
 - Power-on Reset (POR)
 - Power-up Timer (PWRT)
 - Oscillator Start-up Timer (OST)
 - Brown-out Reset (BOR)
- Interrupts (Section 6.0)
- Watchdog Timer (WDT)
- SLEEP mode
- Code protection

The PIC17CXXX has a Watchdog Timer which can be shut-off only through EPROM bits. It runs off its own RC oscillator for added reliability. There are two timers that offer necessary delays on POR and BOR. One is the Oscillator Start-up Timer (OST), intended to keep the chip in RESET until the crystal oscillator is stable. The other is the Power-up Timer (PWRT), which provides a fixed delay of 96 ms (nominal) on power-up only, designed to keep the part in RESET while the power supply stabilizes. With these two timers on-chip, most applications need no external RESET circuitry.

The SLEEP mode is designed to offer a very low current power-down mode. The user can wake from SLEEP through external RESET, Watchdog Timer Reset, or through an interrupt. Several oscillator options are also made available to allow the part to fit the application. The RC oscillator option saves system cost, while the LF crystal option saves power. Configuration bits are used to select various options. This configuration word has the format shown in Figure 17-1.

REGISTER 17-1: CONFIGURATION WORDS

High (H) Table Read Addr. FE0Fh - FE08h	U-x	R/P-1	R/P-1	U-x	U-x	U-x	U-x	U-x	U-x
	—	PM2	BODEN	—	—	—	—	—	—
	bit 15	bit 8	bit 7						bit 0
Low (L) Table Read Addr. FE07h - FE00h	U-x	U-x	R/P-1	U-x	R/P-1	R/P-1	R/P-1	R/P-1	R/P-1
	—	—	PM1	—	PM0	WDTPS1	WDTPS0	FOSC1	FOSC0
	bit 15	bit 8	bit 7						bit 0

bits 7H, 6L, 4L **PM2, PM1, PM0:** Processor Mode Select bits
 111 = Microprocessor mode
 110 = Microcontroller mode
 101 = Extended Microcontroller mode
 000 = Code Protected Microcontroller mode

bit 6H **BODEN:** Brown-out Detect Enable
 1 = Brown-out Detect circuitry is enabled
 0 = Brown-out Detect circuitry is disabled

bits 3L:2L **WDTPS1:WDTPS0:** WDT Postscaler Select bits
 11 = WDT enabled, postscaler = 1
 10 = WDT enabled, postscaler = 256
 01 = WDT enabled, postscaler = 64
 00 = WDT disabled, 16-bit overflow timer

bits 1L:0L **FOSC1:FOSC0:** Oscillator Select bits
 11 = EC oscillator
 10 = XT oscillator
 01 = RC oscillator
 00 = LF oscillator

Shaded bits (—) **Reserved**

PIC17C7XX

17.1 Configuration Bits

The PIC17CXXX has eight configuration locations (Table 17-1). These locations can be programmed (read as '0'), or left unprogrammed (read as '1') to select various device configurations. Any write to a configuration location, regardless of the data, will program that configuration bit. A `TABLWT` instruction and raising the `MCLR/VPP` pin to the programming voltage are both required to write to program memory locations. The configuration bits can be read by using the `TABLRD` instructions. Reading any configuration location between `FE00h` and `FE07h` will read the low byte of the configuration word (Figure 17-1) into the `TABLATL` register. The `TABLATH` register will be `FFh`. Reading a configuration location between `FE08h` and `FE0Fh` will read the high byte of the configuration word into the `TABLATH` register. The `TABLATH` register will be `FFh`.

Addresses `FE00h` through `FE0Fh` are only in the program memory space for Microcontroller and Code Protected Microcontroller modes. A device programmer will be able to read the configuration word in any processor mode. See programming specifications for more detail.

TABLE 17-1: CONFIGURATION LOCATIONS

Bit	Address
FOSC0	FE00h
FOSC1	FE01h
WDTPS0	FE02h
WDTPS1	FE03h
PM0	FE04h
PM1	FE06h
BODEN	FE0Eh
PM2	FE0Fh

Note: When programming the desired configuration locations, they must be programmed in ascending order, starting with address `FE00h`.

17.2 Oscillator Configurations

17.2.1 OSCILLATOR TYPES

The PIC17CXXX can be operated in four different oscillator modes. The user can program two configuration bits (`FOSC1:FOSC0`) to select one of these four modes:

- LF Low Power Crystal
- XT Crystal/Resonator
- EC External Clock Input
- RC Resistor/Capacitor

For information on the different oscillator types and how to use them, please refer to Section 4.0.

17.3 Watchdog Timer (WDT)

The Watchdog Timer's function is to recover from software malfunction, or to reset the device while in SLEEP mode. The WDT uses an internal free running on-chip RC oscillator for its clock source. This does not require any external components. This RC oscillator is separate from the RC oscillator of the OSC1/CLKIN pin. That means that the WDT will run even if the clock on the OSC1/CLKIN and OSC2/CLKOUT pins has been stopped, for example, by execution of a SLEEP instruction. During normal operation, a WDT time-out generates a device RESET. The WDT can be permanently disabled by programming the configuration bits WDTPS1:WDTPS0 as '00' (Section 17.1).

Under normal operation, the WDT must be cleared on a regular interval. This time must be less than the minimum WDT overflow time. Not clearing the WDT in this time frame will cause the WDT to overflow and reset the device.

17.3.1 WDT PERIOD

The WDT has a nominal time-out period of 12 ms (with postscaler = 1). The time-out periods vary with temperature, VDD and process variations from part to part (see DC specs). If longer time-out periods are desired, configuration bits should be used to enable the WDT with a greater prescale. Thus, typical time-out periods up to 3.0 seconds can be realized.

The CLRWDT and SLEEP instructions clear the WDT and its postscale setting and prevent it from timing out, thus generating a device RESET condition.

The \overline{TO} bit in the CPUSTA register will be cleared upon a WDT time-out.

17.3.2 CLEARING THE WDT AND POSTSCALER

The WDT and postscaler are cleared when:

- The device is in the RESET state
- A SLEEP instruction is executed
- A CLRWDT instruction is executed
- Wake-up from SLEEP by an interrupt

The WDT counter/postscaler will start counting on the first edge after the device exits the RESET state.

17.3.3 WDT PROGRAMMING CONSIDERATIONS

It should also be taken in account that under worst case conditions (VDD = Min., Temperature = Max., Max. WDT postscaler), it may take several seconds before a WDT time-out occurs.

The WDT and postscaler become the Power-up Timer whenever the PWRT is invoked.

17.3.4 WDT AS NORMAL TIMER

When the WDT is selected as a normal timer, the clock source is the device clock. Neither the WDT nor the postscaler are directly readable or writable. The overflow time is 65536 TOSC cycles. On overflow, the \overline{TO} bit is cleared (device is not RESET). The CLRWDT instruction can be used to set the \overline{TO} bit. This allows the WDT to be a simple overflow timer. The simple timer does not increment when in SLEEP.

FIGURE 17-1: WATCHDOG TIMER BLOCK DIAGRAM

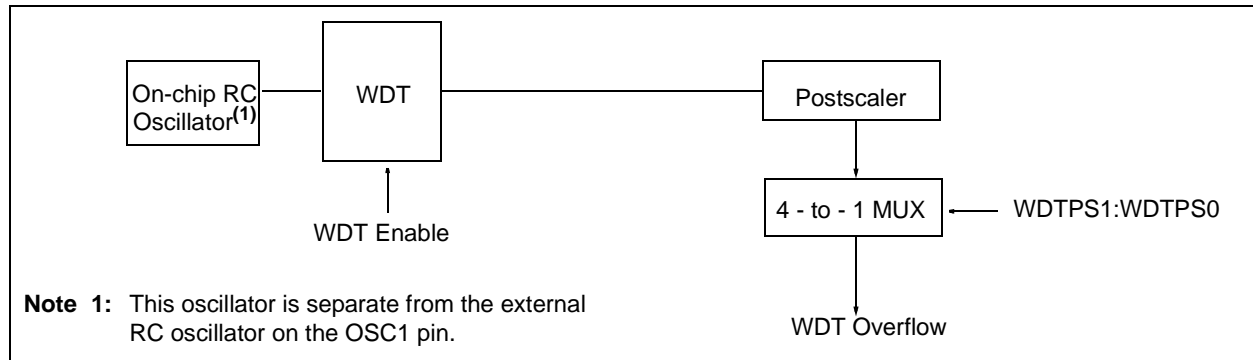

TABLE 17-2: REGISTERS/BITS ASSOCIATED WITH THE WATCHDOG TIMER

Address	Name	Bit 7	Bit 6	Bit 5	Bit 4	Bit 3	Bit 2	Bit 1	Bit 0	Value on POR, BOR	\overline{MCLR} , WDT
—	Config	See Figure 17-1 for location of WDTPSx bits in Configuration Word.								(Note 1)	(Note 1)
06h, Unbanked	CPUSTA	—	—	STKAV	GLINTD	\overline{TO}	\overline{PD}	\overline{POR}	\overline{BOR}	--11 11qq	--11 qqqu

Legend: — = unimplemented, read as '0', q = value depends on condition. Shaded cells are not used by the WDT.

Note 1: This value will be as the device was programmed, or if unprogrammed, will read as all '1's.

PIC17C7XX

17.4 Power-down Mode (SLEEP)

The Power-down mode is entered by executing a `SLEEP` instruction. This clears the Watchdog Timer and postscaler (if enabled). The \overline{PD} bit is cleared and the \overline{TO} bit is set (in the `CPUSTA` register). In SLEEP mode, the oscillator driver is turned off. The I/O ports maintain their status (driving high, low, or hi-impedance input).

The \overline{MCLR}/VPP pin must be at a logic high level (V_{IHMC}). A WDT time-out RESET does not drive the \overline{MCLR}/VPP pin low.

17.4.1 WAKE-UP FROM SLEEP

The device can wake-up from SLEEP through one of the following events:

- Power-on Reset
- Brown-out Reset
- External RESET input on \overline{MCLR}/VPP pin
- WDT Reset (if WDT was enabled)
- Interrupt from `RA0/INT` pin, `RB` port change, `T0CKI` interrupt, or some peripheral interrupts

The following peripheral interrupts can wake the device from SLEEP:

- Capture interrupts
- USART synchronous slave transmit interrupts
- USART synchronous slave receive interrupts
- A/D conversion complete
- SPI slave transmit/receive complete
- I²C slave receive

Other peripherals cannot generate interrupts since during SLEEP, no on-chip Q clocks are present.

Any RESET event will cause a device RESET. Any interrupt event is considered a continuation of program execution. The \overline{TO} and \overline{PD} bits in the `CPUSTA` register can be used to determine the cause of a device RESET. The \overline{PD} bit, which is set on power-up, is cleared when SLEEP is invoked. The \overline{TO} bit is cleared if WDT time-out occurred (and caused a RESET).

When the `SLEEP` instruction is being executed, the next instruction (`PC + 1`) is pre-fetched. For the device to wake-up through an interrupt event, the corresponding interrupt enable bit must be set (enabled). Wake-up is regardless of the state of the `GLINTD` bit. If the `GLINTD` bit is set (disabled), the device continues execution at the instruction after the `SLEEP` instruction. If the `GLINTD` bit is clear (enabled), the device executes the instruction after the `SLEEP` instruction and then branches to the interrupt vector address. In cases where the execution of the instruction following SLEEP is not desirable, the user should have a `NOP` after the `SLEEP` instruction.

Note: If the global interrupt is disabled (`GLINTD` is set), but any interrupt source has both its interrupt enable bit and the corresponding interrupt flag bit set, the device will immediately wake-up from SLEEP. The \overline{TO} bit is set and the \overline{PD} bit is cleared.

The WDT is cleared when the device wakes from SLEEP, regardless of the source of wake-up.

17.4.1.1 Wake-up Delay

When the oscillator type is configured in XT or LF mode, the Oscillator Start-up Timer (OST) is activated on wake-up. The OST will keep the device in RESET for $1024T_{osc}$. This needs to be taken into account when considering the interrupt response time when coming out of SLEEP.

FIGURE 17-2: WAKE-UP FROM SLEEP THROUGH INTERRUPT

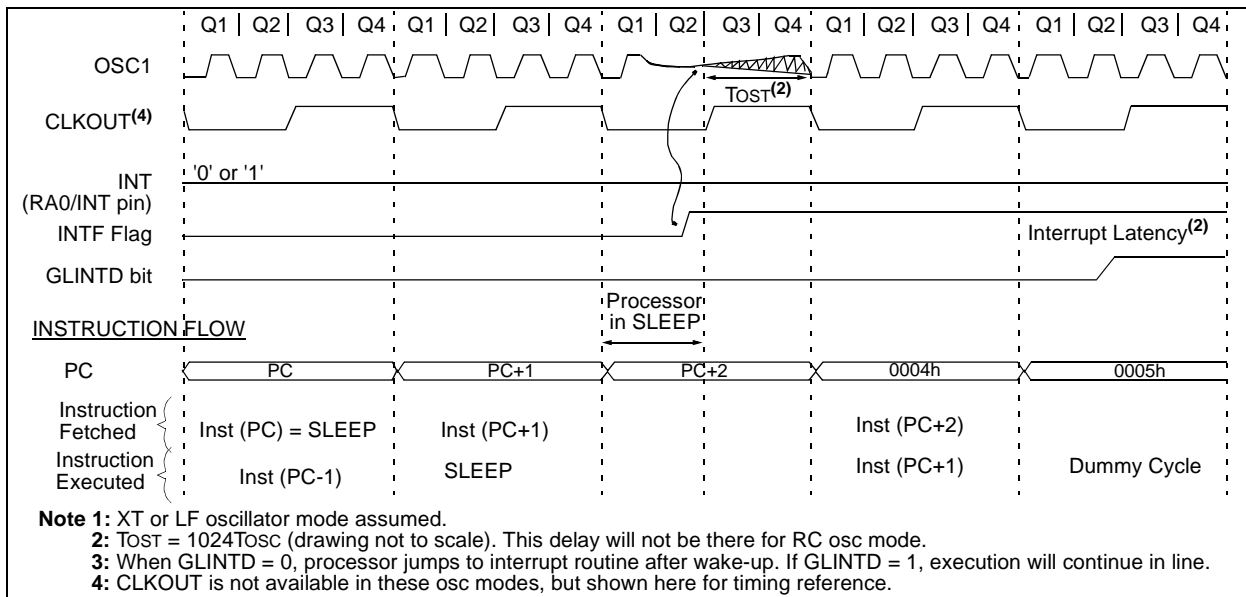

17.4.2 MINIMIZING CURRENT CONSUMPTION

To minimize current consumption, all I/O pins should be either at VDD, or VSS, with no external circuitry drawing current from the I/O pin. I/O pins that are hi-impedance inputs should be pulled high or low externally to avoid switching currents caused by floating inputs. The T0CKI input should be at VDD or VSS. The contributions from on-chip pull-ups on PORTB should also be considered and disabled, when possible.

17.5 Code Protection

The code in the program memory can be protected by selecting the microcontroller in Code Protected mode (PM2:PM0 = '000').

In this mode, instructions that are in the on-chip program memory space, can continue to read or write the program memory. An instruction that is executed outside of the internal program memory range will be inhibited from writing to, or reading from, program memory.

Note: Microchip does not recommend code protecting windowed devices.

If the code protection bit(s) have not been programmed, the on-chip program memory can be read out for verification purposes.

PIC17C7XX

17.6 In-Circuit Serial Programming

The PIC17C7XX group of the high-end family (PIC17CXXX) has an added feature that allows serial programming while in the end application circuit. This is simply done with two lines for clock and data and three other lines for power, ground, and the programming voltage. This allows customers to manufacture boards with unprogrammed devices and then program the microcontroller just before shipping the product. This also allows the most recent firmware, or a custom firmware to be programmed.

Devices may be serialized to make the product unique; “special” variants of the product may be offered and code updates are possible. This allows for increased design flexibility.

To place the device into the Serial Programming Test mode, two pins will need to be placed at V_{IH} . These are the TEST pin and the MCLR/VPP pin. Also, a sequence of events must occur as follows:

1. The TEST pin is placed at V_{IH} .
2. The MCLR/VPP pin is placed at V_{IH} .

There is a setup time between step 1 and step 2 that must be met.

After this sequence, the Program Counter is pointing to program memory address 0xFF60. This location is in the Boot ROM. The code initializes the USART/SCI so that it can receive commands. For this, the device must be clocked. The device clock source in this mode is the RA1/T0CKI pin. After delaying to allow the USART/SCI to initialize, commands can be received. The flow is shown in these 3 steps:

1. The device clock source starts.
2. Wait 80 device clocks for Boot ROM code to configure the USART/SCI.
3. Commands may now be sent.

For complete details of serial programming, please refer to the PIC17C7XX Programming Specification. (Contact your local Microchip Technology Sales Office for availability.)

FIGURE 17-3: TYPICAL IN-CIRCUIT SERIAL PROGRAMMING CONNECTION

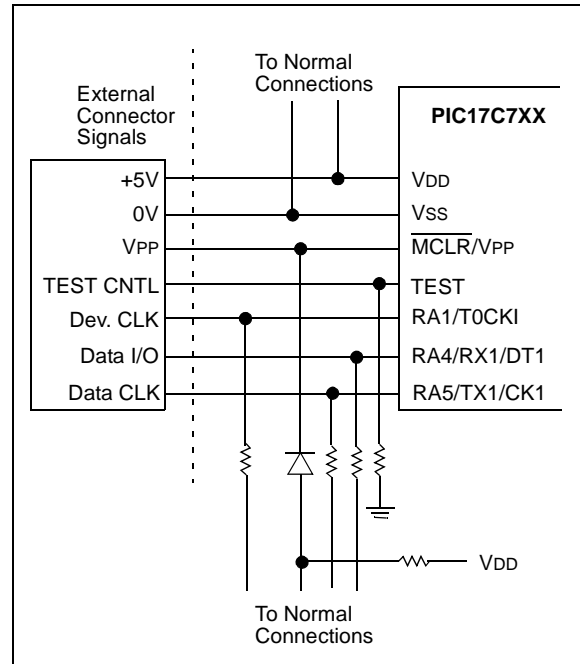

TABLE 17-3: ICSP INTERFACE PINS

Name	During Programming		
	Function	Type	Description
RA4/RX1/DT1	DT	I/O	Serial Data
RA5/TX1/CK1	CK	I	Serial Clock
RA1/T0CKI	OSCI	I	Device Clock Source
TEST	TEST	I	Test mode selection control input, force to V_{IH}
MCLR/VPP	MCLR/VPP	P	Master Clear Reset and Device Programming Voltage
VDD	VDD	P	Positive supply for logic and I/O pins
VSS	VSS	P	Ground reference for logic and I/O pins

18.0 INSTRUCTION SET SUMMARY

The PIC17CXXX instruction set consists of 58 instructions. Each instruction is a 16-bit word divided into an OPCODE and one or more operands. The opcode specifies the instruction type, while the operand(s) further specify the operation of the instruction. The PIC17CXXX instruction set can be grouped into three types:

- byte-oriented
- bit-oriented
- literal and control operations

These formats are shown in Figure 18-1.

Table 18-1 shows the field descriptions for the opcodes. These descriptions are useful for understanding the opcodes in Table 18-2 and in each specific instruction descriptions.

For **byte-oriented instructions**, 'f' represents a file register designator and 'd' represents a destination designator. The file register designator specifies which file register is to be used by the instruction.

The destination designator specifies where the result of the operation is to be placed. If 'd' = '0', the result is placed in the WREG register. If 'd' = '1', the result is placed in the file register specified by the instruction.

For **bit-oriented instructions**, 'b' represents a bit field designator which selects the number of the bit affected by the operation, while 'f' represents the number of the file in which the bit is located.

For **literal and control operations**, 'k' represents an 8- or 13-bit constant or literal value.

The instruction set is highly orthogonal and is grouped into:

- byte-oriented operations
- bit-oriented operations
- literal and control operations

All instructions are executed within one single instruction cycle, unless:

- a conditional test is true
- the program counter is changed as a result of an instruction
- a table read or a table write instruction is executed (in this case, the execution takes two instruction cycles with the second cycle executed as a NOP)

One instruction cycle consists of four oscillator periods. Thus, for an oscillator frequency of 25 MHz, the normal instruction execution time is 160 ns. If a conditional test is true or the program counter is changed as a result of an instruction, the instruction execution time is 320 ns.

TABLE 18-1: OPCODE FIELD DESCRIPTIONS

Field	Description
f	Register file address (00h to FFh)
p	Peripheral register file address (00h to 1Fh)
i	Table pointer control i = '0' (do not change) i = '1' (increment after instruction execution)
t	Table byte select t = '0' (perform operation on lower byte) t = '1' (perform operation on upper byte literal field, constant data)
WREG	Working register (accumulator)
b	Bit address within an 8-bit file register
k	Literal field, constant data or label
x	Don't care location (= '0' or '1') The assembler will generate code with x = '0'. It is the recommended form of use for compatibility with all Microchip software tools.
d	Destination select 0 = store result in WREG 1 = store result in file register f Default is d = '1'
u	Unused, encoded as '0'
s	Destination select 0 = store result in file register f and in the WREG 1 = store result in file register f Default is s = '1'
label	Label name
C, DC, Z, OV	ALU status bits Carry, Digit Carry, Zero, Overflow
GLINTD	Global Interrupt Disable bit (CPUTA<4>)
TBLPTR	Table Pointer (16-bit)
TBLAT	Table Latch (16-bit) consists of high byte (TBLATH) and low byte (TBLATL)
TBLATL	Table Latch low byte
TBLATH	Table Latch high byte
TOS	Top-of-Stack
PC	Program Counter
BSR	Bank Select Register
WDT	Watchdog Timer Counter
\overline{TO}	Time-out bit
\overline{PD}	Power-down bit
dest	Destination either the WREG register or the specified register file location
[]	Options
()	Contents
→	Assigned to
< >	Register bit field
∈	In the set of
<i>italics</i>	User defined term (font is courier)

PIC17C7XX

Table 18-2 lists the instructions recognized by the MPASM assembler.

Note 1: Any unused opcode is Reserved. Use of any reserved opcode may cause unexpected operation.

All instruction examples use the following format to represent a hexadecimal number:

0xhh

where h signifies a hexadecimal digit.

To represent a binary number:

0000 0100b

where b signifies a binary string.

FIGURE 18-1: GENERAL FORMAT FOR INSTRUCTIONS

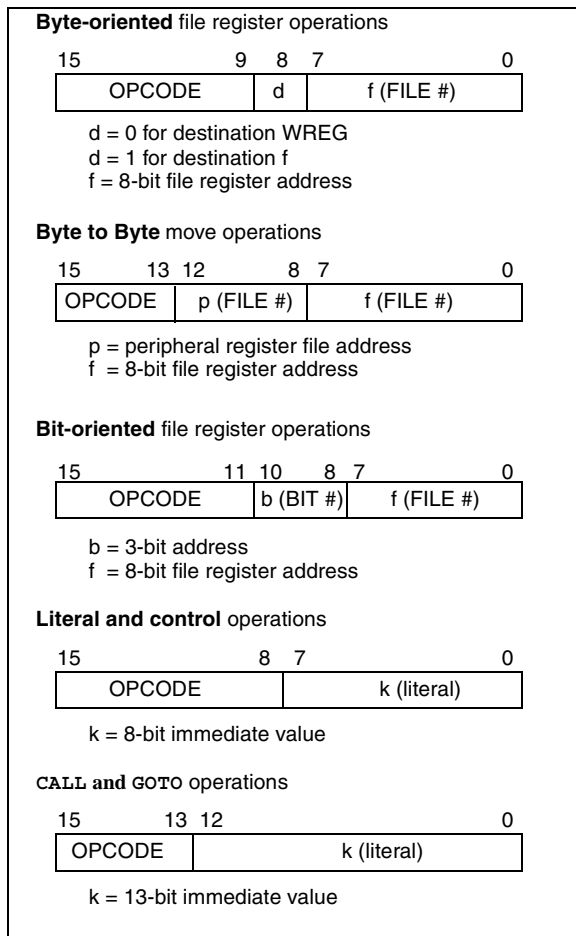

18.1 Special Function Registers as Source/Destination

The PIC17C7XX's orthogonal instruction set allows read and write of all file registers, including special function registers. There are some special situations the user should be aware of:

18.1.1 ALUSTA AS DESTINATION

If an instruction writes to ALUSTA, the Z, C, DC and OV bits may be set or cleared as a result of the instruction and overwrite the original data bits written. For example, executing `CLRF ALUSTA` will clear register ALUSTA and then set the Z bit leaving `0000 0100b` in the register.

18.1.2 PCL AS SOURCE OR DESTINATION

Read, write or read-modify-write on PCL may have the following results:

Read PC: PCH → PCLATH; PCL → dest

Write PCL: PCLATH → PCH;
8-bit destination value → PCL

Read-Modify-Write: PCL → ALU operand
PCLATH → PCH;
8-bit result → PCL

Where PCH = program counter high byte (not an addressable register), PCLATH = Program counter high holding latch, dest = destination, WREG or f.

18.1.3 BIT MANIPULATION

All bit manipulation instructions are done by first reading the entire register, operating on the selected bit and writing the result back (read-modify-write (R-M-W)). The user should keep this in mind when operating on some special function registers, such as ports.

Note: Status bits that are manipulated by the device (including the interrupt flag bits) are set or cleared in the Q1 cycle. So, there is no issue on doing R-M-W instructions on registers which contain these bits

18.2 Q Cycle Activity

Each instruction cycle (Tcy) is comprised of four Q cycles (Q1-Q4). The Q cycle is the same as the device oscillator cycle (Tosc). The Q cycles provide the timing/designation for the Decode, Read, Process Data, Write, etc., of each instruction cycle. The following diagram shows the relationship of the Q cycles to the instruction cycle.

The four Q cycles that make up an instruction cycle (Tcy) can be generalized as:

Q1: Instruction Decode Cycle or forced No operation

Q2: Instruction Read Cycle or No operation

Q3: Process the Data

Q4: Instruction Write Cycle or No operation

Each instruction will show the detailed Q cycle operation for the instruction.

FIGURE 18-2: Q CYCLE ACTIVITY

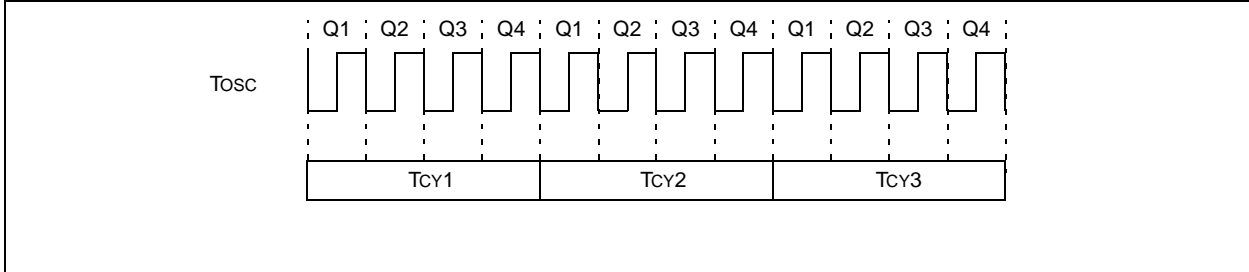

PIC17C7XX

TABLE 18-2: PIC17CXXX INSTRUCTION SET

Mnemonic, Operands	Description	Cycles	16-bit Opcode		Status Affected	Notes
			MSb	LSb		
BYTE-ORIENTED FILE REGISTER OPERATIONS						
ADDWF f,d	ADD WREG to f	1	0000	111d ffff ffff	OV,C,DC,Z	
ADDWFC f,d	ADD WREG and Carry bit to f	1	0001	000d ffff ffff	OV,C,DC,Z	
ANDWF f,d	AND WREG with f	1	0000	101d ffff ffff	Z	
CLRF f,s	Clear f, or Clear f and Clear WREG	1	0010	100s ffff ffff	None	3
COMF f,d	Complement f	1	0001	001d ffff ffff	Z	
CPFSEQ f	Compare f with WREG, skip if f = WREG	1 (2)	0011	0001 ffff ffff	None	6,8
CPFSGT f	Compare f with WREG, skip if f > WREG	1 (2)	0011	0010 ffff ffff	None	2,6,8
CPFSLT f	Compare f with WREG, skip if f < WREG	1 (2)	0011	0000 ffff ffff	None	2,6,8
DAW f,s	Decimal Adjust WREG Register	1	0010	111s ffff ffff	C	3
DECF f,d	Decrement f	1	0000	011d ffff ffff	OV,C,DC,Z	
DECFSZ f,d	Decrement f, skip if 0	1 (2)	0001	011d ffff ffff	None	6,8
DCFSNZ f,d	Decrement f, skip if not 0	1 (2)	0010	011d ffff ffff	None	6,8
INCF f,d	Increment f	1	0001	010d ffff ffff	OV,C,DC,Z	
INCFSZ f,d	Increment f, skip if 0	1 (2)	0001	111d ffff ffff	None	6,8
INFSNZ f,d	Increment f, skip if not 0	1 (2)	0010	010d ffff ffff	None	6,8
IORWF f,d	Inclusive OR WREG with f	1	0000	100d ffff ffff	Z	
MOVFP f,p	Move f to p	1	011p	pppp ffff ffff	None	
MOVPF p,f	Move p to f	1	010p	pppp ffff ffff	Z	
MOVWF f	Move WREG to f	1	0000	0001 ffff ffff	None	
MULWF f	Multiply WREG with f	1	0011	0100 ffff ffff	None	
NEGW f,s	Negate WREG	1	0010	110s ffff ffff	OV,C,DC,Z	1,3
NOP —	No Operation	1	0000	0000 0000 0000	None	
RLCF f,d	Rotate left f through Carry	1	0001	101d ffff ffff	C	
RLNCF f,d	Rotate left f (no carry)	1	0010	001d ffff ffff	None	
RRCF f,d	Rotate right f through Carry	1	0001	100d ffff ffff	C	
RRNCF f,d	Rotate right f (no carry)	1	0010	000d ffff ffff	None	
SETF f,s	Set f	1	0010	101s ffff ffff	None	3
SUBWF f,d	Subtract WREG from f	1	0000	010d ffff ffff	OV,C,DC,Z	1
SUBWFB f,d	Subtract WREG from f with Borrow	1	0000	001d ffff ffff	OV,C,DC,Z	1
SWAPF f,d	Swap f	1	0001	110d ffff ffff	None	
TABLRD t,i,f	Table Read	2 (3)	1010	10ti ffff ffff	None	7
TABLWT t,i,f	Table Write	2	1010	11ti ffff ffff	None	5
TLRD t,f	Table Latch Read	1	1010	00tx ffff ffff	None	
TLWT t,f	Table Latch Write	1	1010	01tx ffff ffff	None	

Legend: Refer to Table 18-1 for opcode field descriptions.

Note 1: 2's Complement method.

2: Unsigned arithmetic.

3: If s = '1', only the file is affected; If s = '0', both the WREG register and the file are affected; If only the Working register (WREG) is required to be affected, then f = WREG must be specified.

4: During an LCALL, the contents of PCLATH are loaded into the MSB of the PC and kkkk kkkk is loaded into the LSB of the PC (PCL).

5: Multiple cycle instruction for EPROM programming when table pointer selects internal EPROM. The instruction is terminated by an interrupt event. When writing to external program memory, it is a two-cycle instruction.

6: Two-cycle instruction when condition is true, else single cycle instruction.

7: Two-cycle instruction except for TABLRD to PCL (program counter low byte), in which case it takes 3 cycles.

8: A "skip" means that instruction fetched during execution of current instruction is not executed, instead a NOP is executed.

TABLE 18-2: PIC17CXXX INSTRUCTION SET (CONTINUED)

Mnemonic, Operands	Description	Cycles	16-bit Opcode				Status Affected	Notes
			MSb		LSb			
TSTFSZ f	Test f, skip if 0	1 (2)	0011	0011	ffff	ffff	None	6,8
XORWF f,d	Exclusive OR WREG with f	1	0000	110d	ffff	ffff	Z	
BIT-ORIENTED FILE REGISTER OPERATIONS								
BCF f,b	Bit Clear f	1	1000	1bbb	ffff	ffff	None	
BSF f,b	Bit Set f	1	1000	0bbb	ffff	ffff	None	
BTFSC f,b	Bit test, skip if clear	1 (2)	1001	1bbb	ffff	ffff	None	6,8
BTFSS f,b	Bit test, skip if set	1 (2)	1001	0bbb	ffff	ffff	None	6,8
BTG f,b	Bit Toggle f	1	0011	1bbb	ffff	ffff	None	
LITERAL AND CONTROL OPERATIONS								
ADDLW k	ADD literal to WREG	1	1011	0001	kkkk	kkkk	OV,C,DC,Z	
ANDLW k	AND literal with WREG	1	1011	0101	kkkk	kkkk	Z	
CALL k	Subroutine Call	2	111k	kkkk	kkkk	kkkk	None	7
CLRWDT —	Clear Watchdog Timer	1	0000	0000	0000	0100	\overline{TO} , \overline{PD}	
GOTO k	Unconditional Branch	2	110k	kkkk	kkkk	kkkk	None	7
IORLW k	Inclusive OR literal with WREG	1	1011	0011	kkkk	kkkk	Z	
LCALL k	Long Call	2	1011	0111	kkkk	kkkk	None	4,7
MOVLB k	Move literal to low nibble in BSR	1	1011	1000	uuuu	kkkk	None	
MOVLR k	Move literal to high nibble in BSR	1	1011	101x	kkkk	uuuu	None	
MOVLW k	Move literal to WREG	1	1011	0000	kkkk	kkkk	None	
MULLW k	Multiply literal with WREG	1	1011	1100	kkkk	kkkk	None	
RETFIE —	Return from interrupt (and enable interrupts)	2	0000	0000	0000	0101	GLINTD	7
RETLW k	Return literal to WREG	2	1011	0110	kkkk	kkkk	None	7
RETURN —	Return from subroutine	2	0000	0000	0000	0010	None	7
SLEEP —	Enter SLEEP mode	1	0000	0000	0000	0011	\overline{TO} , \overline{PD}	
SUBLW k	Subtract WREG from literal	1	1011	0010	kkkk	kkkk	OV,C,DC,Z	
XORLW k	Exclusive OR literal with WREG	1	1011	0100	kkkk	kkkk	Z	

Legend: Refer to Table 18-1 for opcode field descriptions.

Note 1: 2's Complement method.

2: Unsigned arithmetic.

3: If s = '1', only the file is affected: If s = '0', both the WREG register and the file are affected; If only the Working register (WREG) is required to be affected, then f = WREG must be specified.

4: During an LCALL, the contents of PCLATH are loaded into the MSB of the PC and kkkk kkkk is loaded into the LSB of the PC (PCL).

5: Multiple cycle instruction for EPROM programming when table pointer selects internal EPROM. The instruction is terminated by an interrupt event. When writing to external program memory, it is a two-cycle instruction.

6: Two-cycle instruction when condition is true, else single cycle instruction.

7: Two-cycle instruction except for TABLRD to PCL (program counter low byte), in which case it takes 3 cycles.

8: A "skip" means that instruction fetched during execution of current instruction is not executed, instead a NOP is executed.

PIC17C7XX

ADDLW ADD Literal to WREG

Syntax: [*label*] ADDLW k
 Operands: $0 \leq k \leq 255$
 Operation: (WREG) + k → (WREG)
 Status Affected: OV, C, DC, Z
 Encoding:

1011	0001	kkkk	kkkk
------	------	------	------

 Description: The contents of WREG are added to the 8-bit literal 'k' and the result is placed in WREG.
 Words: 1
 Cycles: 1
 Q Cycle Activity:

Q1	Q2	Q3	Q4
Decode	Read literal 'k'	Process Data	Write to WREG

Example: ADDLW 0x15

Before Instruction
 WREG = 0x10
 After Instruction
 WREG = 0x25

ADDWF ADD WREG to f

Syntax: [*label*] ADDWF f,d
 Operands: $0 \leq f \leq 255$
 $d \in [0,1]$
 Operation: (WREG) + (f) → (dest)
 Status Affected: OV, C, DC, Z
 Encoding:

0000	111d	ffff	ffff
------	------	------	------

 Description: Add WREG to register 'f'. If 'd' is 0 the result is stored in WREG. If 'd' is 1 the result is stored back in register 'f'.
 Words: 1
 Cycles: 1
 Q Cycle Activity:

Q1	Q2	Q3	Q4
Decode	Read register 'f'	Process Data	Write to destination

Example: ADDWF REG, 0

Before Instruction
 WREG = 0x17
 REG = 0xC2
 After Instruction
 WREG = 0xD9
 REG = 0xC2

ADDWFC **ADD WREG and Carry bit to f**

Syntax: [*label*] ADDWFC f,d

Operands: $0 \leq f \leq 255$
 $d \in [0,1]$

Operation: (WREG) + (f) + C → (dest)

Status Affected: OV, C, DC, Z

Encoding:

0001	000d	ffff	ffff
------	------	------	------

Description: Add WREG, the Carry Flag and data memory location 'f'. If 'd' is 0, the result is placed in WREG. If 'd' is 1, the result is placed in data memory location 'f'.

Words: 1

Cycles: 1

Q Cycle Activity:

Q1	Q2	Q3	Q4
Decode	Read register 'f'	Process Data	Write to destination

Example: ADDWFC REG 0

Before Instruction

Carry bit = 1

REG = 0x02

WREG = 0x4D

After Instruction

Carry bit = 0

REG = 0x02

WREG = 0x50

ANDLW **And Literal with WREG**

Syntax: [*label*] ANDLW k

Operands: $0 \leq k \leq 255$

Operation: (WREG) .AND. (k) → (WREG)

Status Affected: Z

Encoding:

1011	0101	kkkk	kkkk
------	------	------	------

Description: The contents of WREG are AND'ed with the 8-bit literal 'k'. The result is placed in WREG.

Words: 1

Cycles: 1

Q Cycle Activity:

Q1	Q2	Q3	Q4
Decode	Read literal 'k'	Process Data	Write to WREG

Example: ANDLW 0x5F

Before Instruction

WREG = 0xA3

After Instruction

WREG = 0x03

PIC17C7XX

ANDWF AND WREG with f

Syntax: [*label*] ANDWF f,d

Operands: $0 \leq f \leq 255$
 $d \in [0,1]$

Operation: (WREG) .AND. (f) → (dest)

Status Affected: Z

Encoding:

0000	101d	ffff	ffff
------	------	------	------

Description: The contents of WREG are AND'ed with register 'f'. If 'd' is 0 the result is stored in WREG. If 'd' is 1 the result is stored back in register 'f'.

Words: 1

Cycles: 1

Q Cycle Activity:

Q1	Q2	Q3	Q4
Decode	Read register 'f'	Process Data	Write to destination

Example: ANDWF REG, 1

Before Instruction
WREG = 0x17
REG = 0xC2

After Instruction
WREG = 0x17
REG = 0x02

BCF Bit Clear f

Syntax: [*label*] BCF f,b

Operands: $0 \leq f \leq 255$
 $0 \leq b \leq 7$

Operation: $0 \rightarrow (f)$

Status Affected: None

Encoding:

1000	1bbb	ffff	ffff
------	------	------	------

Description: Bit 'b' in register 'f' is cleared.

Words: 1

Cycles: 1

Q Cycle Activity:

Q1	Q2	Q3	Q4
Decode	Read register 'f'	Process Data	Write register 'f'

Example: BCF FLAG_REG, 7

Before Instruction
FLAG_REG = 0xC7

After Instruction
FLAG_REG = 0x47

BSF	Bit Set f								
Syntax:	[<i>label</i>] BSF f,b								
Operands:	0 ≤ f ≤ 255 0 ≤ b ≤ 7								
Operation:	1 → (f)								
Status Affected:	None								
Encoding:	<table border="1" style="display: inline-table;"><tr><td>1000</td><td>0bbb</td><td>ffff</td><td>ffff</td></tr></table>	1000	0bbb	ffff	ffff				
1000	0bbb	ffff	ffff						
Description:	Bit 'b' in register 'f' is set.								
Words:	1								
Cycles:	1								
Q Cycle Activity:									
	<table border="1" style="display: inline-table;"><tr><th>Q1</th><th>Q2</th><th>Q3</th><th>Q4</th></tr><tr><td>Decode</td><td>Read register 'f'</td><td>Process Data</td><td>Write register 'f'</td></tr></table>	Q1	Q2	Q3	Q4	Decode	Read register 'f'	Process Data	Write register 'f'
Q1	Q2	Q3	Q4						
Decode	Read register 'f'	Process Data	Write register 'f'						

Example: BSF FLAG_REG, 7

Before Instruction
FLAG_REG = 0x0A

After Instruction
FLAG_REG = 0x8A

BTFSC	Bit Test, skip if Clear								
Syntax:	[<i>label</i>] BTFSC f,b								
Operands:	0 ≤ f ≤ 255 0 ≤ b ≤ 7								
Operation:	skip if (f) = 0								
Status Affected:	None								
Encoding:	<table border="1" style="display: inline-table;"><tr><td>1001</td><td>1bbb</td><td>ffff</td><td>ffff</td></tr></table>	1001	1bbb	ffff	ffff				
1001	1bbb	ffff	ffff						
Description:	If bit 'b' in register 'f' is 0, then the next instruction is skipped. If bit 'b' is 0, then the next instruction fetched during the current instruction execution is discarded and a NOP is executed instead, making this a two-cycle instruction.								
Words:	1								
Cycles:	1(2)								
Q Cycle Activity:									
	<table border="1" style="display: inline-table;"><tr><th>Q1</th><th>Q2</th><th>Q3</th><th>Q4</th></tr><tr><td>Decode</td><td>Read register 'f'</td><td>Process Data</td><td>No operation</td></tr></table>	Q1	Q2	Q3	Q4	Decode	Read register 'f'	Process Data	No operation
Q1	Q2	Q3	Q4						
Decode	Read register 'f'	Process Data	No operation						
If skip:									
	<table border="1" style="display: inline-table;"><tr><th>Q1</th><th>Q2</th><th>Q3</th><th>Q4</th></tr><tr><td>No operation</td><td>No operation</td><td>No operation</td><td>No operation</td></tr></table>	Q1	Q2	Q3	Q4	No operation	No operation	No operation	No operation
Q1	Q2	Q3	Q4						
No operation	No operation	No operation	No operation						

Example: HERE BTFSC FLAG, 1
 FALSE :
 TRUE :

Before Instruction
PC = address (HERE)

After Instruction
If FLAG<1> = 0;
PC = address (TRUE)
If FLAG<1> = 1;
PC = address (FALSE)

PIC17C7XX

BTFSS **Bit Test, skip if Set**

Syntax: [*label*] BTFSS f,b

Operands: $0 \leq f \leq 127$
 $0 \leq b < 7$

Operation: skip if (f) = 1

Status Affected: None

Encoding:

1001	0bbb	ffff	ffff
------	------	------	------

Description: If bit 'b' in register 'f' is 1, then the next instruction is skipped.
 If bit 'b' is 1, then the next instruction fetched during the current instruction execution is discarded and a NOP is executed instead, making this a two-cycle instruction.

Words: 1

Cycles: 1(2)

Q Cycle Activity:

Q1	Q2	Q3	Q4
Decode	Read register 'f'	Process Data	No operation

If skip:

Q1	Q2	Q3	Q4
No operation	No operation	No operation	No operation

Example: HERE BTFSS FLAG, 1
 FALSE :
 TRUE :

Before Instruction

PC = address (HERE)

After Instruction

If FLAG<1> = 0;
 PC = address (FALSE)
 If FLAG<1> = 1;
 PC = address (TRUE)

BTG **Bit Toggle f**

Syntax: [*label*] BTG f,b

Operands: $0 \leq f \leq 255$
 $0 \leq b < 7$

Operation: $\overline{(f)} \rightarrow (f)$

Status Affected: None

Encoding:

0011	1bbb	ffff	ffff
------	------	------	------

Description: Bit 'b' in data memory location 'f' is inverted.

Words: 1

Cycles: 1

Q Cycle Activity:

Q1	Q2	Q3	Q4
Decode	Read register 'f'	Process Data	Write register 'f'

Example: BTG PORTC, 4

Before Instruction:

PORTC = 0111 0101 [0x75]

After Instruction:

PORTC = 0110 0101 [0x65]

CALL Subroutine Call

Syntax: `[label] CALL k`

Operands: $0 \leq k \leq 8191$

Operation: $PC+1 \rightarrow TOS$, $k \rightarrow PC<12:0>$,
 $k<12:8> \rightarrow PCLATH<4:0>$;
 $PC<15:13> \rightarrow PCLATH<7:5>$

Status Affected: None

Encoding:

111k	kkkk	kkkk	kkkk
------	------	------	------

Description: Subroutine call within 8K page. First, return address (PC+1) is pushed onto the stack. The 13-bit value is loaded into PC bits<12:0>. Then the upper-eight bits of the PC are copied into PCLATH. CALL is a two-cycle instruction.
 See LCALL for calls outside 8K memory space.

Words: 1

Cycles: 2

Q Cycle Activity:

Q1	Q2	Q3	Q4
Decode	Read literal 'k'<7:0>, Push PC to stack	Process Data	Write to PC
No operation	No operation	No operation	No operation

Example: `HERE CALL THERE`

Before Instruction
`PC = Address (HERE)`

After Instruction
`PC = Address (THERE)`
`TOS = Address (HERE + 1)`

CLRF Clear f

Syntax: `[label] CLRF f,s`

Operands: $0 \leq f \leq 255$

Operation: $00h \rightarrow f$, $s \in [0,1]$
 $00h \rightarrow dest$

Status Affected: None

Encoding:

0010	100s	ffff	ffff
------	------	------	------

Description: Clears the contents of the specified register(s).
 $s = 0$: Data memory location 'f' and WREG are cleared.
 $s = 1$: Data memory location 'f' is cleared.

Words: 1

Cycles: 1

Q Cycle Activity:

Q1	Q2	Q3	Q4
Decode	Read register 'f'	Process Data	Write register 'f' and if specified WREG

Example: `CLRF FLAG_REG, 1`

Before Instruction
`FLAG_REG = 0x5A`
`WREG = 0x01`

After Instruction
`FLAG_REG = 0x00`
`WREG = 0x01`

PIC17C7XX

CLRWDT Clear Watchdog Timer

Syntax: [*label*] CLRWDT

Operands: None

Operation: 00h → WDT
0 → WDT postscaler,
1 → \overline{TO}
1 → \overline{PD}

Status Affected: \overline{TO} , \overline{PD}

Encoding:

0000	0000	0000	0100
------	------	------	------

Description: CLRWDT instruction resets the Watchdog Timer. It also resets the postscaler of the WDT. Status bits \overline{TO} and \overline{PD} are set.

Words: 1

Cycles: 1

Q Cycle Activity:

Q1	Q2	Q3	Q4
Decode	No operation	Process Data	No operation

Example: CLRWDT

Before Instruction
WDT counter = ?

After Instruction
WDT counter = 0x00
WDT Postscaler = 0
 \overline{TO} = 1
 \overline{PD} = 1

COMF Complement f

Syntax: [*label*] COMF f,d

Operands: $0 \leq f \leq 255$
 $d \in [0,1]$

Operation: $\overline{(f)} \rightarrow (\text{dest})$

Status Affected: Z

Encoding:

0001	001d	ffff	ffff
------	------	------	------

Description: The contents of register 'f' are complemented. If 'd' is 0 the result is stored in WREG. If 'd' is 1 the result is stored back in register 'f'.

Words: 1

Cycles: 1

Q Cycle Activity:

Q1	Q2	Q3	Q4
Decode	Read register 'f'	Process Data	Write to destination

Example: COMF REG1,0

Before Instruction
REG1 = 0x13

After Instruction
REG1 = 0x13
WREG = 0xEC

CPFSEQ **Compare f with WREG, skip if f = WREG**

Syntax: `[label] CPFSEQ f`

Operands: $0 \leq f \leq 255$

Operation: (f) – (WREG), skip if (f) = (WREG) (unsigned comparison)

Status Affected: None

Encoding:

0011	0001	ffff	ffff
------	------	------	------

Description: Compares the contents of data memory location 'f' to the contents of WREG by performing an unsigned subtraction. If 'f' = WREG, then the fetched instruction is discarded and a NOP is executed instead, making this a two-cycle instruction.

Words: 1

Cycles: 1 (2)

Q Cycle Activity:

Q1	Q2	Q3	Q4
Decode	Read register 'f'	Process Data	No operation

If skip:

Q1	Q2	Q3	Q4
No operation	No operation	No operation	No operation

Example:

```

HERE    CPFSEQ REG
NEQUAL  :
EQUAL   :
```

Before Instruction

```

PC Address = HERE
WREG       = ?
REG        = ?
```

After Instruction

```

If REG     = WREG;
PC         = Address (EQUAL)
If REG     ≠ WREG;
PC         = Address (NEQUAL)
```

CPFSGT **Compare f with WREG, skip if f > WREG**

Syntax: `[label] CPFSGT f`

Operands: $0 \leq f \leq 255$

Operation: (f) – (WREG), skip if (f) > (WREG) (unsigned comparison)

Status Affected: None

Encoding:

0011	0010	ffff	ffff
------	------	------	------

Description: Compares the contents of data memory location 'f' to the contents of the WREG by performing an unsigned subtraction. If the contents of 'f' are greater than the contents of WREG, then the fetched instruction is discarded and a NOP is executed instead, making this a two-cycle instruction.

Words: 1

Cycles: 1 (2)

Q Cycle Activity:

Q1	Q2	Q3	Q4
Decode	Read register 'f'	Process Data	No operation

If skip:

Q1	Q2	Q3	Q4
No operation	No operation	No operation	No operation

Example:

```

HERE    CPFSGT REG
NGREATER :
GREATER  :
```

Before Instruction

```

PC       = Address (HERE)
WREG     = ?
```

After Instruction

```

If REG   > WREG;
PC       = Address (GREATER)
If REG   £ WREG;
PC       = Address (NGREATER)
```

PIC17C7XX

Compare f with WREG, skip if f < WREG

CPFSLT

Syntax: `[label] CPFSLT f`

Operands: $0 \leq f \leq 255$

Operation: $(f) - (WREG)$,
skip if $(f) < (WREG)$
(unsigned comparison)

Status Affected: None

Encoding:

0011	0000	ffff	ffff
------	------	------	------

Description: Compares the contents of data memory location 'f' to the contents of WREG by performing an unsigned subtraction. If the contents of 'f' are less than the contents of WREG, then the fetched instruction is discarded and a NOP is executed instead, making this a two-cycle instruction.

Words: 1

Cycles: 1 (2)

Q Cycle Activity:

Q1	Q2	Q3	Q4
Decode	Read register 'f'	Process Data	No operation

If skip:

Q1	Q2	Q3	Q4
No operation	No operation	No operation	No operation

Example:

```
HERE CPFSLT REG
:
NLESS :
:
LESS :
```

Before Instruction

```
PC = Address (HERE)
W = ?
```

After Instruction

```
If REG < WREG;
PC = Address (LESS)
If REG ≥ WREG;
PC = Address (NLESS)
```

DAW

Decimal Adjust WREG Register

Syntax: `[label] DAW f,s`

Operands: $0 \leq f \leq 255$
 $s \in [0,1]$

Operation: If $[(WREG<7:4> > 9).OR.[C = 1]].AND.[WREG<3:0> > 9]$
then
 $WREG<7:4> + 7 \rightarrow f<7:4>, s<7:4>;$

If $[WREG<7:4> > 9].OR.[C = 1]$
then
 $WREG<7:4> + 6 \rightarrow f<7:4>, s<7:4>;$
else
 $WREG<7:4> \rightarrow f<7:4>, s<7:4>;$

If $[WREG<3:0> > 9].OR.[DC = 1]$
then
 $WREG<3:0> + 6 \rightarrow f<3:0>, s<3:0>;$
else
 $WREG<3:0> \rightarrow f<3:0>, s<3:0>$

Status Affected: C

Encoding:

0010	111s	ffff	ffff
------	------	------	------

Description: DAW adjusts the eight-bit value in WREG, resulting from the earlier addition of two variables (each in packed BCD format) and produces a correct packed BCD result.
 $s = 0$: Result is placed in Data memory location 'f' and WREG.
 $s = 1$: Result is placed in Data memory location 'f'.

Words: 1

Cycles: 1

Q Cycle Activity:

Q1	Q2	Q3	Q4
Decode	Read register 'f'	Process Data	Write register 'f' and other specified register

Example:

```
DAW REG1, 0
```

Before Instruction

```
WREG = 0xA5
REG1 = ??
C = 0
DC = 0
```

After Instruction

```
WREG = 0x05
REG1 = 0x05
C = 1
DC = 0
```

DECF	Decrement f								
Syntax:	[<i>label</i>] DECF f,d								
Operands:	0 ≤ f ≤ 255 d ∈ [0,1]								
Operation:	(f) − 1 → (dest)								
Status Affected:	OV, C, DC, Z								
Encoding:	<table border="1" style="display: inline-table;"><tr><td>0000</td><td>011d</td><td>ffff</td><td>ffff</td></tr></table>	0000	011d	ffff	ffff				
0000	011d	ffff	ffff						
Description:	Decrement register 'f'. If 'd' is 0, the result is stored in WREG. If 'd' is 1, the result is stored back in register 'f'.								
Words:	1								
Cycles:	1								
Q Cycle Activity:	<table border="1" style="display: inline-table;"><thead><tr><th>Q1</th><th>Q2</th><th>Q3</th><th>Q4</th></tr></thead><tbody><tr><td>Decode</td><td>Read register 'f'</td><td>Process Data</td><td>Write to destination</td></tr></tbody></table>	Q1	Q2	Q3	Q4	Decode	Read register 'f'	Process Data	Write to destination
Q1	Q2	Q3	Q4						
Decode	Read register 'f'	Process Data	Write to destination						

Example: DECF CNT, 1

Before Instruction

CNT = 0x01
Z = 0

After Instruction

CNT = 0x00
Z = 1

DECFSZ	Decrement f, skip if 0								
Syntax:	[<i>label</i>] DECFSZ f,d								
Operands:	0 ≤ f ≤ 255 d ∈ [0,1]								
Operation:	(f) − 1 → (dest); skip if result = 0								
Status Affected:	None								
Encoding:	<table border="1" style="display: inline-table;"><tr><td>0001</td><td>011d</td><td>ffff</td><td>ffff</td></tr></table>	0001	011d	ffff	ffff				
0001	011d	ffff	ffff						
Description:	The contents of register 'f' are decremented. If 'd' is 0, the result is placed in WREG. If 'd' is 1, the result is placed back in register 'f'. If the result is 0, the next instruction, which is already fetched is discarded and a NOP is executed instead, making it a two-cycle instruction.								
Words:	1								
Cycles:	1(2)								
Q Cycle Activity:	<table border="1" style="display: inline-table;"><thead><tr><th>Q1</th><th>Q2</th><th>Q3</th><th>Q4</th></tr></thead><tbody><tr><td>Decode</td><td>Read register 'f'</td><td>Process Data</td><td>Write to destination</td></tr></tbody></table>	Q1	Q2	Q3	Q4	Decode	Read register 'f'	Process Data	Write to destination
Q1	Q2	Q3	Q4						
Decode	Read register 'f'	Process Data	Write to destination						
If skip:	<table border="1" style="display: inline-table;"><thead><tr><th>Q1</th><th>Q2</th><th>Q3</th><th>Q4</th></tr></thead><tbody><tr><td>No operation</td><td>No operation</td><td>No operation</td><td>No operation</td></tr></tbody></table>	Q1	Q2	Q3	Q4	No operation	No operation	No operation	No operation
Q1	Q2	Q3	Q4						
No operation	No operation	No operation	No operation						

Example: HERE DECFSZ CNT, 1
 GOTO HERE

 NZERO
 ZERO

Before Instruction

PC = Address (HERE)

After Instruction

CNT = CNT - 1
If CNT = 0;
 PC = Address (HERE)
If CNT ≠ 0;
 PC = Address (NZERO)

PIC17C7XX

DCFSNZ Decrement f, skip if not 0

Syntax: `[label] DCFSNZ f,d`

Operands: $0 \leq f \leq 255$
 $d \in [0,1]$

Operation: $(f) - 1 \rightarrow (\text{dest});$
 skip if not 0

Status Affected: None

Encoding:

0010	011d	ffff	ffff
------	------	------	------

Description: The contents of register 'f' are decremented. If 'd' is 0, the result is placed in WREG. If 'd' is 1, the result is placed back in register 'f'.
 If the result is not 0, the next instruction, which is already fetched is discarded and a NOP is executed instead, making it a two-cycle instruction.

Words: 1

Cycles: 1(2)

Q Cycle Activity:

Q1	Q2	Q3	Q4
Decode	Read register 'f'	Process Data	Write to destination

If skip:

Q1	Q2	Q3	Q4
No operation	No operation	No operation	No operation

Example:

```

HERE    DCFSNZ  TEMP, 1
ZERO    :
NZERO   :
```

Before Instruction

TEMP_VALUE = ?

After Instruction

```

TEMP_VALUE = TEMP_VALUE - 1,
If TEMP_VALUE = 0;
    PC = Address (ZERO)
If TEMP_VALUE ≠ 0;
    PC = Address (NZERO)
```

GOTO Unconditional Branch

Syntax: `[label] GOTO k`

Operands: $0 \leq k \leq 8191$

Operation: $k \rightarrow PC<12:0>;$
 $k<12:8> \rightarrow PCLATH<4:0>;$
 $PC<15:13> \rightarrow PCLATH<7:5>$

Status Affected: None

Encoding:

110k	kkkk	kkkk	kkkk
------	------	------	------

Description: GOTO allows an unconditional branch anywhere within an 8K page boundary. The thirteen-bit immediate value is loaded into PC bits <12:0>. Then the upper eight bits of PC are loaded into PCLATH. GOTO is always a two-cycle instruction.

Words: 1

Cycles: 2

Q Cycle Activity:

Q1	Q2	Q3	Q4
Decode	Read literal 'k'	Process Data	Write to PC
No operation	No operation	No operation	No operation

Example: GOTO THERE

After Instruction

PC = Address (THERE)

INCF **Increment f**

Syntax: `[label] INCF f,d`

Operands: $0 \leq f \leq 255$
 $d \in [0,1]$

Operation: $(f) + 1 \rightarrow (\text{dest})$

Status Affected: OV, C, DC, Z

Encoding:

0001	010d	ffff	ffff
------	------	------	------

Description: The contents of register 'f' are incremented. If 'd' is 0, the result is placed in WREG. If 'd' is 1, the result is placed back in register 'f'.

Words: 1

Cycles: 1

Q Cycle Activity:

Q1	Q2	Q3	Q4
Decode	Read register 'f'	Process Data	Write to destination

Example: `INCF CNT, 1`

Before Instruction

CNT = 0xFF

Z = 0

C = ?

After Instruction

CNT = 0x00

Z = 1

C = 1

INCFSZ **Increment f, skip if 0**

Syntax: `[label] INCFSZ f,d`

Operands: $0 \leq f \leq 255$
 $d \in [0,1]$

Operation: $(f) + 1 \rightarrow (\text{dest})$
skip if result = 0

Status Affected: None

Encoding:

0001	111d	ffff	ffff
------	------	------	------

Description: The contents of register 'f' are incremented. If 'd' is 0, the result is placed in WREG. If 'd' is 1, the result is placed back in register 'f'.
If the result is 0, the next instruction, which is already fetched is discarded and a NOP is executed instead, making it a two-cycle instruction.

Words: 1

Cycles: 1(2)

Q Cycle Activity:

Q1	Q2	Q3	Q4
Decode	Read register 'f'	Process Data	Write to destination

If skip:

Q1	Q2	Q3	Q4
No operation	No operation	No operation	No operation

Example: `HERE INCFSZ CNT, 1`
`NZERO :`
`ZERO :`

Before Instruction

PC = Address (HERE)

After Instruction

CNT = CNT + 1

If CNT = 0;

PC = Address (ZERO)

If CNT \neq 0;

PC = Address (NZERO)

PIC17C7XX

INFSNZ Increment f, skip if not 0

Syntax: `[label] INFSNZ f,d`

Operands: $0 \leq f \leq 255$
 $d \in [0,1]$

Operation: $(f) + 1 \rightarrow (\text{dest})$,
 skip if not 0

Status Affected: None

Encoding:

0010	010d	ffff	ffff
------	------	------	------

Description: The contents of register 'f' are incremented. If 'd' is 0, the result is placed in WREG. If 'd' is 1, the result is placed back in register 'f'.
 If the result is not 0, the next instruction, which is already fetched is discarded and a NOP is executed instead, making it a two-cycle instruction.

Words: 1
 Cycles: 1(2)

Q Cycle Activity:

Q1	Q2	Q3	Q4
Decode	Read register 'f'	Process Data	Write to destination

If skip:

Q1	Q2	Q3	Q4
No operation	No operation	No operation	No operation

Example: `HERE INFSNZ REG, 1`
 `ZERO`
 `NZERO`

Before Instruction
`REG = REG`

After Instruction
`REG = REG + 1`
 If `REG = 1`;
`PC = Address (ZERO)`
 If `REG = 0`;
`PC = Address (NZERO)`

IORLW Inclusive OR Literal with WREG

Syntax: `[label] IORLW k`

Operands: $0 \leq k \leq 255$

Operation: $(\text{WREG}) .\text{OR. } (k) \rightarrow (\text{WREG})$

Status Affected: Z

Encoding:

1011	0011	kkkk	kkkk
------	------	------	------

Description: The contents of WREG are OR'ed with the eight-bit literal 'k'. The result is placed in WREG.

Words: 1
 Cycles: 1

Q Cycle Activity:

Q1	Q2	Q3	Q4
Decode	Read literal 'k'	Process Data	Write to WREG

Example: `IORLW 0x35`

Before Instruction
`WREG = 0x9A`

After Instruction
`WREG = 0xBF`

IORWF	Inclusive OR WREG with f								
Syntax:	[<i>label</i>] IORWF f,d								
Operands:	0 ≤ f ≤ 255 d ∈ [0,1]								
Operation:	(WREG) .OR. (f) → (dest)								
Status Affected:	\bar{Z}								
Encoding:	<table border="1"> <tr> <td>0000</td> <td>100d</td> <td>ffff</td> <td>ffff</td> </tr> </table>	0000	100d	ffff	ffff				
0000	100d	ffff	ffff						
Description:	Inclusive OR WREG with register 'f'. If 'd' is 0, the result is placed in WREG. If 'd' is 1, the result is placed back in register 'f'.								
Words:	1								
Cycles:	1								
Q Cycle Activity:	<table border="1"> <thead> <tr> <th>Q1</th> <th>Q2</th> <th>Q3</th> <th>Q4</th> </tr> </thead> <tbody> <tr> <td>Decode</td> <td>Read register 'f'</td> <td>Process Data</td> <td>Write to destination</td> </tr> </tbody> </table>	Q1	Q2	Q3	Q4	Decode	Read register 'f'	Process Data	Write to destination
Q1	Q2	Q3	Q4						
Decode	Read register 'f'	Process Data	Write to destination						

Example: IORWF RESULT, 0

Before Instruction
 RESULT = 0x13
 WREG = 0x91

After Instruction
 RESULT = 0x13
 WREG = 0x93

LCALL	Long Call												
Syntax:	[<i>label</i>] LCALL k												
Operands:	0 ≤ k ≤ 255												
Operation:	PC + 1 → TOS; k → PCL, (PCLATH) → PCH												
Status Affected:	None												
Encoding:	<table border="1"> <tr> <td>1011</td> <td>0111</td> <td>kkkk</td> <td>kkkk</td> </tr> </table>	1011	0111	kkkk	kkkk								
1011	0111	kkkk	kkkk										
Description:	LCALL allows an unconditional subroutine call to anywhere within the 64K program memory space. First, the return address (PC + 1) is pushed onto the stack. A 16-bit destination address is then loaded into the program counter. The lower 8-bits of the destination address are embedded in the instruction. The upper 8-bits of PC are loaded from PC high holding latch, PCLATH.												
Words:	1												
Cycles:	2												
Q Cycle Activity:	<table border="1"> <thead> <tr> <th>Q1</th> <th>Q2</th> <th>Q3</th> <th>Q4</th> </tr> </thead> <tbody> <tr> <td>Decode</td> <td>Read literal 'k'</td> <td>Process Data</td> <td>Write register PCL</td> </tr> <tr> <td>No operation</td> <td>No operation</td> <td>No operation</td> <td>No operation</td> </tr> </tbody> </table>	Q1	Q2	Q3	Q4	Decode	Read literal 'k'	Process Data	Write register PCL	No operation	No operation	No operation	No operation
Q1	Q2	Q3	Q4										
Decode	Read literal 'k'	Process Data	Write register PCL										
No operation	No operation	No operation	No operation										

Example: MOVLW HIGH(SUBROUTINE)
 MOVWF WREG, PCLATH
 LCALL LOW(SUBROUTINE)

Before Instruction
 SUBROUTINE = 16-bit Address
 PC = ?

After Instruction
 PC = Address (SUBROUTINE)

PIC17C7XX

MOVFP Move f to p

Syntax: `[label] MOVFP f,p`

Operands: $0 \leq f \leq 255$
 $0 \leq p \leq 31$

Operation: (f) → (p)

Status Affected: None

Encoding:

011p	pppp	ffff	ffff
------	------	------	------

Description: Move data from data memory location 'f' to data memory location 'p'. Location 'f' can be anywhere in the 256 byte data space (00h to FFh), while 'p' can be 00h to 1Fh.

Either 'p' or 'f' can be WREG (a useful, special situation).

MOVFP is particularly useful for transferring a data memory location to a peripheral register (such as the transmit buffer or an I/O port). Both 'f' and 'p' can be indirectly addressed.

Words: 1

Cycles: 1

Q Cycle Activity:

Q1	Q2	Q3	Q4
Decode	Read register 'f'	Process Data	Write register 'p'

Example: `MOVFP REG1, REG2`

Before Instruction

REG1 = 0x33,
 REG2 = 0x11

After Instruction

REG1 = 0x33,
 REG2 = 0x33

MOVLB Move Literal to low nibble in BSR

Syntax: `[label] MOVLB k`

Operands: $0 \leq k \leq 15$

Operation: $k \rightarrow (\text{BSR}\langle 3:0 \rangle)$

Status Affected: None

Encoding:

1011	1000	uuuu	kkkk
------	------	------	------

Description: The four-bit literal 'k' is loaded in the Bank Select Register (BSR). Only the low 4-bits of the Bank Select Register are affected. The upper half of the BSR is unchanged. The assembler will encode the "u" fields as '0'.

Words: 1

Cycles: 1

Q Cycle Activity:

Q1	Q2	Q3	Q4
Decode	Read literal 'k'	Process Data	Write literal 'k' to BSR<3:0>

Example: `MOVLB 5`

Before Instruction

BSR register = 0x22

After Instruction

BSR register = 0x25 (Bank 5)

MOVLR **Move Literal to high nibble in BSR**

Syntax: `[label] MOVLR k`

Operands: $0 \leq k \leq 15$

Operation: $k \rightarrow (\text{BSR}<7:4>)$

Status Affected: None

Encoding:

1011	101x	kkkk	uuuu
------	------	------	------

Description: The 4-bit literal 'k' is loaded into the most significant 4-bits of the Bank Select Register (BSR). Only the high 4-bits of the Bank Select Register are affected. The lower half of the BSR is unchanged. The assembler will encode the "u" fields as 0.

Words: 1

Cycles: 1

Q Cycle Activity:

Q1	Q2	Q3	Q4
Decode	Read literal 'k'	Process Data	Write literal 'k' to BSR<7:4>

Example: `MOVLR 5`

Before Instruction
BSR register = 0x22

After Instruction
BSR register = 0x52

MOVLW **Move Literal to WREG**

Syntax: `[label] MOVLW k`

Operands: $0 \leq k \leq 255$

Operation: $k \rightarrow (\text{WREG})$

Status Affected: None

Encoding:

1011	0000	kkkk	kkkk
------	------	------	------

Description: The eight-bit literal 'k' is loaded into WREG.

Words: 1

Cycles: 1

Q Cycle Activity:

Q1	Q2	Q3	Q4
Decode	Read literal 'k'	Process Data	Write to WREG

Example: `MOVLW 0x5A`

After Instruction
WREG = 0x5A

PIC17C7XX

MOVPF Move p to f

Syntax: `[label] MOVPF p,f`

Operands: $0 \leq f \leq 255$
 $0 \leq p \leq 31$

Operation: $(p) \rightarrow (f)$

Status Affected: Z

Encoding:

010p	pppp	ffff	ffff
------	------	------	------

Description: Move data from data memory location 'p' to data memory location 'f'. Location 'f' can be anywhere in the 256 byte data space (00h to FFh), while 'p' can be 00h to 1Fh.
 Either 'p' or 'f' can be WREG (a useful, special situation).
 MOVPF is particularly useful for transferring a peripheral register (e.g. the timer or an I/O port) to a data memory location. Both 'f' and 'p' can be indirectly addressed.

Words: 1

Cycles: 1

Q Cycle Activity:

Q1	Q2	Q3	Q4
Decode	Read register 'p'	Process Data	Write register 'f'

Example: `MOVPF REG1, REG2`

Before Instruction
 REG1 = 0x11
 REG2 = 0x33

After Instruction
 REG1 = 0x11
 REG2 = 0x11

MOVWF Move WREG to f

Syntax: `[label] MOVWF f`

Operands: $0 \leq f \leq 255$

Operation: $(WREG) \rightarrow (f)$

Status Affected: None

Encoding:

0000	0001	ffff	ffff
------	------	------	------

Description: Move data from WREG to register 'f'. Location 'f' can be anywhere in the 256 byte data space.

Words: 1

Cycles: 1

Q Cycle Activity:

Q1	Q2	Q3	Q4
Decode	Read register 'f'	Process Data	Write register 'f'

Example: `MOVWF REG`

Before Instruction
 WREG = 0x4F
 REG = 0xFF

After Instruction
 WREG = 0x4F
 REG = 0x4F

MULLW **Multiply Literal with WREG**

Syntax: [*label*] MULLW k

Operands: $0 \leq k \leq 255$

Operation: $(k \times \text{WREG}) \rightarrow \text{PRODH:PRODL}$

Status Affected: None

Encoding:

1011	1100	kkkk	kkkk
------	------	------	------

Description: An unsigned multiplication is carried out between the contents of WREG and the 8-bit literal 'k'. The 16-bit result is placed in PRODH:PRODL register pair. PRODH contains the high byte.
WREG is unchanged.
None of the status flags are affected.
Note that neither overflow, nor carry is possible in this operation. A zero result is possible, but not detected.

Words: 1

Cycles: 1

Q Cycle Activity:

Q1	Q2	Q3	Q4
Decode	Read literal 'k'	Process Data	Write registers PRODH: PRODL

Example: MULLW 0xC4

Before Instruction

WREG = 0xE2

PRODH = ?

PRODL = ?

After Instruction

WREG = 0xC4

PRODH = 0xAD

PRODL = 0x08

MULWF **Multiply WREG with f**

Syntax: [*label*] MULWF f

Operands: $0 \leq f \leq 255$

Operation: $(\text{WREG} \times f) \rightarrow \text{PRODH:PRODL}$

Status Affected: None

Encoding:

0011	0100	ffff	ffff
------	------	------	------

Description: An unsigned multiplication is carried out between the contents of WREG and the register file location 'f'. The 16-bit result is stored in the PRODH:PRODL register pair. PRODH contains the high byte.
Both WREG and 'f' are unchanged.
None of the status flags are affected.
Note that neither overflow, nor carry is possible in this operation. A zero result is possible, but not detected.

Words: 1

Cycles: 1

Q Cycle Activity:

Q1	Q2	Q3	Q4
Decode	Read register 'f'	Process Data	Write registers PRODH: PRODL

Example: MULWF REG

Before Instruction

WREG = 0xC4

REG = 0xB5

PRODH = ?

PRODL = ?

After Instruction

WREG = 0xC4

REG = 0xB5

PRODH = 0x8A

PRODL = 0x94

PIC17C7XX

NEGW Negate W

Syntax: `[label] NEGW f,s`

Operands: $0 \leq f \leq 255$
 $s \in [0,1]$

Operation: $\overline{WREG} + 1 \rightarrow (f)$;
 $\overline{WREG} + 1 \rightarrow s$

Status Affected: OV, C, DC, Z

Encoding:

0010	110s	ffff	ffff
------	------	------	------

Description: WREG is negated using two's complement. If 's' is 0, the result is placed in WREG and data memory location 'f'. If 's' is 1, the result is placed only in data memory location 'f'.

Words: 1

Cycles: 1

Q Cycle Activity:

Q1	Q2	Q3	Q4
Decode	Read register 'f'	Process Data	Write register 'f' and other specified register

Example: `NEGW REG,0`

Before Instruction

WREG = 0011 1010 [0x3A],
 REG = 1010 1011 [0xAB]

After Instruction

WREG = 1100 0110 [0xC6]
 REG = 1100 0110 [0xC6]

NOP No Operation

Syntax: `[label] NOP`

Operands: None

Operation: No operation

Status Affected: None

Encoding:

0000	0000	0000	0000
------	------	------	------

Description: No operation.

Words: 1

Cycles: 1

Q Cycle Activity:

Q1	Q2	Q3	Q4
Decode	No operation	No operation	No operation

Example:

None.

RETFIE Return from Interrupt

Syntax: [label] RETFIE

Operands: None

Operation: TOS → (PC);
0 → GLINTD;
PCLATH is unchanged.

Status Affected: GLINTD

Encoding:

0000	0000	0000	0101
------	------	------	------

Description: Return from Interrupt. Stack is POP'ed and Top-of-Stack (TOS) is loaded in the PC. Interrupts are enabled by clearing the GLINTD bit. GLINTD is the global interrupt disable bit (CPUSTA<4>).

Words: 1

Cycles: 2

Q Cycle Activity:

	Q1	Q2	Q3	Q4
Decode	Decode	No operation	Clear GLINTD	POP PC from stack
No operation	No operation	No operation	No operation	No operation

Example: RETFIE

After Interrupt
PC = TOS
GLINTD = 0

RETLW Return Literal to WREG

Syntax: [label] RETLW k

Operands: $0 \leq k \leq 255$

Operation: k → (WREG); TOS → (PC);
PCLATH is unchanged

Status Affected: None

Encoding:

1011	0110	kkkk	kkkk
------	------	------	------

Description: WREG is loaded with the eight-bit literal 'k'. The program counter is loaded from the top of the stack (the return address). The high address latch (PCLATH) remains unchanged.

Words: 1

Cycles: 2

Q Cycle Activity:

	Q1	Q2	Q3	Q4
Decode	Decode	Read literal 'k'	Process Data	POP PC from stack, Write to WREG
No operation	No operation	No operation	No operation	No operation

Example:

```
CALL TABLE ; WREG contains table
              ; offset value
              ; WREG now has
              ; table value
:
TABLE
  ADDWF PC ; WREG = offset
  RETLW k0 ; Begin table
  RETLW k1 ;
  :
  :
  RETLW kn ; End of table
```

Before Instruction

WREG = 0x07

After Instruction

WREG = value of k7

PIC17C7XX

RETURN Return from Subroutine

Syntax: [label] RETURN

Operands: None

Operation: TOS → PC;

Status Affected: None

Encoding:

0000	0000	0000	0010
------	------	------	------

Description: Return from subroutine. The stack is popped and the top of the stack (TOS) is loaded into the program counter.

Words: 1

Cycles: 2

Q Cycle Activity:

	Q1	Q2	Q3	Q4
Decode	No operation	Process Data	POP PC from stack	
No operation	No operation	No operation	No operation	

Example: RETURN

After Interrupt
PC = TOS

RLCF Rotate Left f through Carry

Syntax: [label] RLCF f,d

Operands: $0 \leq f \leq 255$
 $d \in [0,1]$

Operation: $f\langle n \rangle \rightarrow d\langle n+1 \rangle$;
 $f\langle 7 \rangle \rightarrow C$;
 $C \rightarrow d\langle 0 \rangle$

Status Affected: C

Encoding:

0001	101d	ffff	ffff
------	------	------	------

Description: The contents of register 'f' are rotated one bit to the left through the Carry Flag. If 'd' is 0, the result is placed in WREG. If 'd' is 1, the result is stored back in register 'f'.

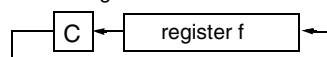

Words: 1

Cycles: 1

Q Cycle Activity:

	Q1	Q2	Q3	Q4
Decode	Read register 'f'	Process Data	Write to destination	

Example: RLCF REG,0

Before Instruction

REG = 1110 0110
C = 0

After Instruction

REG = 1110 0110
WREG = 1100 1100
C = 1

RLNCF Rotate Left f (no carry)

Syntax: [label] RLNCF f,d

Operands: $0 \leq f \leq 255$
 $d \in [0,1]$

Operation: $f\langle n \rangle \rightarrow d\langle n+1 \rangle$;
 $f\langle 7 \rangle \rightarrow d\langle 0 \rangle$

Status Affected: None

Encoding:

0010	001d	ffff	ffff
------	------	------	------

Description: The contents of register 'f' are rotated one bit to the left. If 'd' is 0, the result is placed in WREG. If 'd' is 1, the result is stored back in register 'f'.

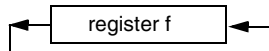

Words: 1

Cycles: 1

Q Cycle Activity:

Q1	Q2	Q3	Q4
Decode	Read register 'f'	Process Data	Write to destination

Example: RLNCF REG, 1

Before Instruction

C = 0
 REG = 1110 1011

After Instruction

C =
 REG = 1101 0111

RRCF Rotate Right f through Carry

Syntax: [label] RRCF f,d

Operands: $0 \leq f \leq 255$
 $d \in [0,1]$

Operation: $f\langle n \rangle \rightarrow d\langle n-1 \rangle$;
 $f\langle 0 \rangle \rightarrow C$;
 $C \rightarrow d\langle 7 \rangle$

Status Affected: C

Encoding:

0001	100d	ffff	ffff
------	------	------	------

Description: The contents of register 'f' are rotated one bit to the right through the Carry Flag. If 'd' is 0, the result is placed in WREG. If 'd' is 1, the result is placed back in register 'f'.

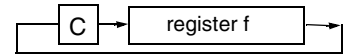

Words: 1

Cycles: 1

Q Cycle Activity:

Q1	Q2	Q3	Q4
Decode	Read register 'f'	Process Data	Write to destination

Example: RRCF REG1, 0

Before Instruction

REG1 = 1110 0110
 C = 0

After Instruction

REG1 = 1110 0110
 WREG = 0111 0011
 C = 0

PIC17C7XX

RRNCF Rotate Right f (no carry)

Syntax: [label] RRNCF f,d

Operands: $0 \leq f \leq 255$
 $d \in [0,1]$

Operation: $f\langle n \rangle \rightarrow d\langle n-1 \rangle$;
 $f\langle 0 \rangle \rightarrow d\langle 7 \rangle$

Status Affected: None

Encoding:

0010	000d	ffff	ffff
------	------	------	------

Description: The contents of register 'f' are rotated one bit to the right. If 'd' is 0, the result is placed in WREG. If 'd' is 1, the result is placed back in register 'f'.

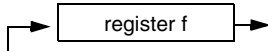

Words: 1

Cycles: 1

Q Cycle Activity:

Q1	Q2	Q3	Q4
Decode	Read register 'f'	Process Data	Write to destination

Example 1: RRNCF REG, 1

Before Instruction
WREG = ?
REG = 1101 0111

After Instruction
WREG = 0
REG = 1110 1011

Example 2: RRNCF REG, 0

Before Instruction
WREG = ?
REG = 1101 0111

After Instruction
WREG = 1110 1011
REG = 1101 0111

SETF Set f

Syntax: [label] SETF f,s

Operands: $0 \leq f \leq 255$
 $s \in [0,1]$

Operation: FFh \rightarrow f;
FFh \rightarrow d

Status Affected: None

Encoding:

0010	101s	ffff	ffff
------	------	------	------

Description: If 's' is 0, both the data memory location 'f' and WREG are set to FFh. If 's' is 1, only the data memory location 'f' is set to FFh.

Words: 1

Cycles: 1

Q Cycle Activity:

Q1	Q2	Q3	Q4
Decode	Read register 'f'	Process Data	Write register 'f' and other specified register

Example1: SETF REG, 0

Before Instruction
REG = 0xDA
WREG = 0x05

After Instruction
REG = 0xFF
WREG = 0xFF

Example2: SETF REG, 1

Before Instruction
REG = 0xDA
WREG = 0x05

After Instruction
REG = 0xFF
WREG = 0x05

SLEEP Enter SLEEP mode

Syntax: [*label*] SLEEP

Operands: None

Operation: 00h → WDT;
0 → WDT postscaler;
1 → \overline{TO} ;
0 → PD

Status Affected: \overline{TO} , PD

Encoding:

0000	0000	0000	0011
------	------	------	------

Description: The power-down status bit (\overline{PD}) is cleared. The time-out status bit (\overline{TO}) is set. Watchdog Timer and its postscaler are cleared.
The processor is put into SLEEP mode with the oscillator stopped.

Words: 1

Cycles: 1

Q Cycle Activity:

Q1	Q2	Q3	Q4
Decode	No operation	Process Data	Go to sleep

Example: SLEEP

Before Instruction

\overline{TO} = ?

PD = ?

After Instruction

\overline{TO} = 1 †

PD = 0

† If WDT causes wake-up, this bit is cleared

SUBLW Subtract WREG from Literal

Syntax: [*label*] SUBLW k

Operands: $0 \leq k \leq 255$

Operation: $k - (WREG) \rightarrow (WREG)$

Status Affected: OV, C, DC, Z

Encoding:

1011	0010	kkkk	kkkk
------	------	------	------

Description: WREG is subtracted from the eight-bit literal 'k'. The result is placed in WREG.

Words: 1

Cycles: 1

Q Cycle Activity:

Q1	Q2	Q3	Q4
Decode	Read literal 'k'	Process Data	Write to WREG

Example 1: SUBLW 0x02

Before Instruction

WREG = 1

C = ?

After Instruction

WREG = 1

C = 1 ; result is positive

Z = 0

Example 2:

Before Instruction

WREG = 2

C = ?

After Instruction

WREG = 0

C = 1 ; result is zero

Z = 1

Example 3:

Before Instruction

WREG = 3

C = ?

After Instruction

WREG = FF ; (2's complement)

C = 0 ; result is negative

Z = 0

PIC17C7XX

SUBWF		Subtract WREG from f	
Syntax:	[<i>label</i>] SUBWF f,d		
Operands:	0 ≤ f ≤ 255 d ∈ [0,1]		
Operation:	(f) – (W) → (dest)		
Status Affected:	OV, C, DC, Z		
Encoding:	0000	010d	ffff ffff
Description:	Subtract WREG from register 'f' (2's complement method). If 'd' is 0, the result is stored in WREG. If 'd' is 1, the result is stored back in register 'f'.		
Words:	1		
Cycles:	1		
Q Cycle Activity:			
	Q1	Q2	Q3
	Decode	Read register 'f'	Process Data
			Write to destination

Example 1: SUBWF REG1, 1

Before Instruction

REG1 = 3
WREG = 2
C = ?

After Instruction

REG1 = 1
WREG = 2
C = 1 ; result is positive
Z = 0

Example 2:

Before Instruction

REG1 = 2
WREG = 2
C = ?

After Instruction

REG1 = 0
WREG = 2
C = 1 ; result is zero
Z = 1

Example 3:

Before Instruction

REG1 = 1
WREG = 2
C = ?

After Instruction

REG1 = FF
WREG = 2
C = 0 ; result is negative
Z = 0

SUBWFB		Subtract WREG from f with Borrow	
Syntax:	[<i>label</i>] SUBWFB f,d		
Operands:	0 ≤ f ≤ 255 d ∈ [0,1]		
Operation:	(f) – (W) – \bar{C} → (dest)		
Status Affected:	OV, C, DC, Z		
Encoding:	0000	001d	ffff ffff
Description:	Subtract WREG and the carry flag (borrow) from register 'f' (2's complement method). If 'd' is 0, the result is stored in WREG. If 'd' is 1, the result is stored back in register 'f'.		
Words:	1		
Cycles:	1		
Q Cycle Activity:			
	Q1	Q2	Q3
	Decode	Read register 'f'	Process Data
			Write to destination

Example 1: SUBWFB REG1, 1

Before Instruction

REG1 = 0x19 (0001 1001)
WREG = 0x0D (0000 1101)
C = 1

After Instruction

REG1 = 0x0C (0000 1011)
WREG = 0x0D (0000 1101)
C = 1 ; result is positive
Z = 0

Example 2: SUBWFB REG1, 0

Before Instruction

REG1 = 0x1B (0001 1011)
WREG = 0x1A (0001 1010)
C = 0

After Instruction

REG1 = 0x1B (0001 1011)
WREG = 0x00
C = 1 ; result is zero
Z = 1

Example 3: SUBWFB REG1, 1

Before Instruction

REG1 = 0x03 (0000 0011)
WREG = 0x0E (0000 1101)
C = 1

After Instruction

REG1 = 0xF5 (1111 0100) [2's comp]
WREG = 0x0E (0000 1101)
C = 0 ; result is negative
Z = 0

SWAPF **Swap f**

Syntax: [*label*] SWAPF f,d

Operands: $0 \leq f \leq 255$
 $d \in [0,1]$

Operation: $f\langle 3:0 \rangle \rightarrow \text{dest}\langle 7:4 \rangle;$
 $f\langle 7:4 \rangle \rightarrow \text{dest}\langle 3:0 \rangle$

Status Affected: None

Encoding:

0001	110d	ffff	ffff
------	------	------	------

Description: The upper and lower nibbles of register 'f' are exchanged. If 'd' is 0, the result is placed in WREG. If 'd' is 1, the result is placed in register 'f'.

Words: 1

Cycles: 1

Q Cycle Activity:

Q1	Q2	Q3	Q4
Decode	Read register 'f'	Process Data	Write to destination

Example: SWAPF REG, 0

Before Instruction
REG = 0x53

After Instruction
REG = 0x35

TABLRD **Table Read**

Syntax: [*label*] TABLRD t,i,f

Operands: $0 \leq f \leq 255$
 $i \in [0,1]$
 $t \in [0,1]$

Operation: If $t = 1$,
TBLATH $\rightarrow f$;
If $t = 0$,
TBLATL $\rightarrow f$;
Prog Mem (TBLPTR) \rightarrow TBLAT;
If $i = 1$,
TBLPTR + 1 \rightarrow TBLPTR
If $i = 0$,
TBLPTR is unchanged

Status Affected: None

Encoding:

1010	10ti	ffff	ffff
------	------	------	------

Description:

1. A byte of the table latch (TBLAT) is moved to register file 'f'.
If $t = 1$: the high byte is moved;
If $t = 0$: the low byte is moved.
2. Then, the contents of the program memory location pointed to by the 16-bit Table Pointer (TBLPTR) are loaded into the 16-bit Table Latch (TBLAT).
3. If $i = 1$: TBLPTR is incremented;
If $i = 0$: TBLPTR is not incremented.

Words: 1

Cycles: 2 (3-cycle if $f = \text{PCL}$)

Q Cycle Activity:

Q1	Q2	Q3	Q4
Decode	Read register TBLATH or TBLATL	Process Data	Write register 'f'
No operation	No operation (Table Pointer on Address bus)	No operation	No operation (OE goes low)

PIC17C7XX

TABLRD Table Read

Example1: TABLRD 1, 1, REG ;

Before Instruction

```
REG           = 0x53
TBLATH       = 0xAA
TBLATL       = 0x55
TBLPTR       = 0xA356
MEMORY(TBLPTR) = 0x1234
```

After Instruction (table write completion)

```
REG           = 0xAA
TBLATH       = 0x12
TBLATL       = 0x34
TBLPTR       = 0xA357
MEMORY(TBLPTR) = 0x5678
```

Example2: TABLRD 0, 0, REG ;

Before Instruction

```
REG           = 0x53
TBLATH       = 0xAA
TBLATL       = 0x55
TBLPTR       = 0xA356
MEMORY(TBLPTR) = 0x1234
```

After Instruction (table write completion)

```
REG           = 0x55
TBLATH       = 0x12
TBLATL       = 0x34
TBLPTR       = 0xA356
MEMORY(TBLPTR) = 0x1234
```

TABLWT Table Write

Syntax: [label] TABLWT t,i,f

Operands: $0 \leq f \leq 255$
 $i \in [0,1]$
 $t \in [0,1]$

Operation: If $t = 0$,
 $f \rightarrow$ TBLATL;
 If $t = 1$,
 $f \rightarrow$ TBLATH;
 TBLAT \rightarrow Prog Mem (TBLPTR);
 If $i = 1$,
 TBLPTR + 1 \rightarrow TBLPTR
 If $i = 0$,
 TBLPTR is unchanged

Status Affected: None

Encoding:

1010	11ti	ffff	ffff
------	------	------	------

Description: 1. Load value in 'f' into 16-bit table latch (TBLAT)
 If $t = 1$: load into high byte;
 If $t = 0$: load into low byte
 2. The contents of TBLAT are written to the program memory location pointed to by TBLPTR.
 If TBLPTR points to external program memory location, then the instruction takes two-cycle.
 If TBLPTR points to an internal EPROM location, then the instruction is terminated when an interrupt is received.

Note: The $\overline{\text{MCLR}}/\text{VPP}$ pin must be at the programming voltage for successful programming of internal memory.
 If $\text{MCLR}/\text{VPP} = \text{VDD}$ the programming sequence of internal memory will be interrupted. A short write will occur (2 Tcy). The internal memory location will not be affected.

3. The TBLPTR can be automatically incremented
 If $i = 1$; TBLPTR is not incremented
 If $i = 0$; TBLPTR is incremented

Words: 1

Cycles: 2 (many if write is to on-chip EPROM program memory)

Q Cycle Activity:

Q1	Q2	Q3	Q4
Decode	Read register 'f'	Process Data	Write register TBLATH or TBLATL
No operation	No operation (Table Pointer on Address bus)	No operation	No operation (Table Latch on Address bus, WR goes low)

TABLWT Table Write

Example 1: TABLWT 1, 1, REG

Before Instruction

REG	=	0x53
TBLATH	=	0xAA
TBLATL	=	0x55
TBLPTR	=	0xA356
MEMORY(TBLPTR)	=	0xFFFF

After Instruction (table write completion)

REG	=	0x53
TBLATH	=	0x53
TBLATL	=	0x55
TBLPTR	=	0xA357
MEMORY(TBLPTR - 1)	=	0x5355

Example 2: TABLWT 0, 0, REG

Before Instruction

REG	=	0x53
TBLATH	=	0xAA
TBLATL	=	0x55
TBLPTR	=	0xA356
MEMORY(TBLPTR)	=	0xFFFF

After Instruction (table write completion)

REG	=	0x53
TBLATH	=	0xAA
TBLATL	=	0x53
TBLPTR	=	0xA356
MEMORY(TBLPTR)	=	0xAA53

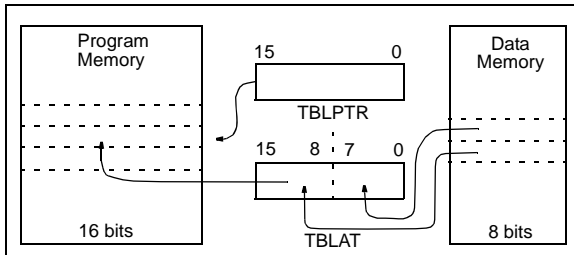

TLRD Table Latch Read

Syntax: [label] TLRD t,f

Operands: $0 \leq f \leq 255$
 $t \in [0,1]$

Operation: If $t = 0$,
 TBLATL \rightarrow f;
 If $t = 1$,
 TBLATH \rightarrow f

Status Affected: None

Encoding:

1010	00tx	ffff	ffff
------	------	------	------

Description: Read data from 16-bit table latch (TBLAT) into file register 'f'. Table Latch is unaffected.
 If $t = 1$; high byte is read
 If $t = 0$; low byte is read
 This instruction is used in conjunction with TABLWD to transfer data from program memory to data memory.

Words: 1

Cycles: 1

Q Cycle Activity:

Q1	Q2	Q3	Q4
Decode	Read register TBLATH or TBLATL	Process Data	Write register 'f'

Example: TLRD t, RAM

Before Instruction

t	=	0
RAM	=	?
TBLAT	=	0x00AF (TBLATH = 0x00) (TBLATL = 0xAF)

After Instruction

RAM	=	0xAF
TBLAT	=	0x00AF (TBLATH = 0x00) (TBLATL = 0xAF)

Before Instruction

t	=	1
RAM	=	?
TBLAT	=	0x00AF (TBLATH = 0x00) (TBLATL = 0xAF)

After Instruction

RAM	=	0x00
TBLAT	=	0x00AF (TBLATH = 0x00) (TBLATL = 0xAF)

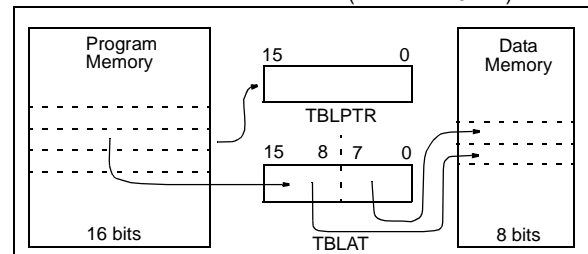

PIC17C7XX

TLWT Table Latch Write

Syntax: [*label*] TLWT *t*,*f*

Operands: $0 \leq f \leq 255$
 $t \in [0,1]$

Operation: If $t = 0$,
 $f \rightarrow$ TBLATL;
 If $t = 1$,
 $f \rightarrow$ TBLATH

Status Affected: None

Encoding:

1010	01tx	ffff	ffff
------	------	------	------

Description: Data from file register 'f' is written into the 16-bit table latch (TBLAT).
 If $t = 1$; high byte is written
 If $t = 0$; low byte is written
 This instruction is used in conjunction with TABLWT to transfer data from data memory to program memory.

Words: 1

Cycles: 1

Q Cycle Activity:

Q1	Q2	Q3	Q4
Decode	Read register 'f'	Process Data	Write register TBLATH or TBLATL

Example: TLWT *t*, RAM

Before Instruction

t = 0
 RAM = 0xB7
 TBLAT = 0x0000 (TBLATH = 0x00)
 (TBLATL = 0x00)

After Instruction

RAM = 0xB7
 TBLAT = 0x00B7 (TBLATH = 0x00)
 (TBLATL = 0xB7)

Before Instruction

t = 1
 RAM = 0xB7
 TBLAT = 0x0000 (TBLATH = 0x00)
 (TBLATL = 0x00)

After Instruction

RAM = 0xB7
 TBLAT = 0xB700 (TBLATH = 0xB7)
 (TBLATL = 0x00)

TSTFSZ Test f, skip if 0

Syntax: [*label*] TSTFSZ *f*

Operands: $0 \leq f \leq 255$

Operation: skip if $f = 0$

Status Affected: None

Encoding:

0011	0011	ffff	ffff
------	------	------	------

Description: If 'f' = 0, the next instruction, fetched during the current instruction execution, is discarded and a NOP is executed, making this a two-cycle instruction.

Words: 1

Cycles: 1 (2)

Q Cycle Activity:

Q1	Q2	Q3	Q4
Decode	Read register 'f'	Process Data	No operation

If skip:

Q1	Q2	Q3	Q4
No operation	No operation	No operation	No operation

Example:

```

HERE    TSTFSZ  CNT
NZERO   :
ZERO    :
```

Before Instruction

PC = Address (HERE)

After Instruction

If CNT = 0x00,
 PC = Address (ZERO)
 If CNT \neq 0x00,
 PC = Address (NZERO)

XORLW **Exclusive OR Literal with WREG**

Syntax: [*label*] XORLW *k*

Operands: $0 \leq k \leq 255$

Operation: (WREG) .XOR. *k* → (WREG)

Status Affected: Z

Encoding:

1011	0100	kkkk	kkkk
------	------	------	------

Description: The contents of WREG are XOR'ed with the 8-bit literal 'k'. The result is placed in WREG.

Words: 1

Cycles: 1

Q Cycle Activity:

Q1	Q2	Q3	Q4
Decode	Read literal 'k'	Process Data	Write to WREG

Example: XORLW 0xAF

Before Instruction

WREG = 0xB5

After Instruction

WREG = 0x1A

XORWF **Exclusive OR WREG with f**

Syntax: [*label*] XORWF *f,d*

Operands: $0 \leq f \leq 255$
 $d \in [0,1]$

Operation: (WREG) .XOR. (*f*) → (*dest*)

Status Affected: Z

Encoding:

0000	110d	ffff	ffff
------	------	------	------

Description: Exclusive OR the contents of WREG with register 'f'. If 'd' is 0, the result is stored in WREG. If 'd' is 1, the result is stored back in the register 'f'.

Words: 1

Cycles: 1

Q Cycle Activity:

Q1	Q2	Q3	Q4
Decode	Read register 'f'	Process Data	Write to destination

Example: XORWF REG, 1

Before Instruction

REG = 0xAF 1010 1111

WREG = 0xB5 1011 0101

After Instruction

REG = 0x1A 0001 1010

WREG = 0xB5

PIC17C7XX

NOTES:

19.0 DEVELOPMENT SUPPORT

The PIC[®] microcontrollers are supported with a full range of hardware and software development tools:

- Integrated Development Environment
 - MPLAB[®] IDE Software
- Assemblers/Compilers/Linkers
 - MPASM[™] Assembler
 - MPLAB C17 and MPLAB C18 C Compilers
 - MPLINK[™] Object Linker/
MPLIB[™] Object Librarian
- Simulators
 - MPLAB SIM Software Simulator
- Emulators
 - MPLAB ICE 2000 In-Circuit Emulator
 - ICEPIC[™] In-Circuit Emulator
- In-Circuit Debugger
 - MPLAB ICD for PIC16F87X
- Device Programmers
 - PRO MATE[®] II Universal Device Programmer
 - PICSTART[®] Plus Entry-Level Development Programmer
- Low Cost Demonstration Boards
 - PICDEM[™] 1 Demonstration Board
 - PICDEM 2 Demonstration Board
 - PICDEM 3 Demonstration Board
 - PICDEM 17 Demonstration Board
 - KEELOQ[®] Demonstration Board

19.1 MPLAB Integrated Development Environment Software

The MPLAB IDE software brings an ease of software development previously unseen in the 8-bit microcontroller market. The MPLAB IDE is a Windows[®]-based application that contains:

- An interface to debugging tools
 - simulator
 - programmer (sold separately)
 - emulator (sold separately)
 - in-circuit debugger (sold separately)
- A full-featured editor
- A project manager
- Customizable toolbar and key mapping
- A status bar
- On-line help

The MPLAB IDE allows you to:

- Edit your source files (either assembly or 'C')
- One touch assemble (or compile) and download to PIC MCU emulator and simulator tools (automatically updates all project information)
- Debug using:
 - source files
 - absolute listing file
 - machine code

The ability to use MPLAB IDE with multiple debugging tools allows users to easily switch from the cost-effective simulator to a full-featured emulator with minimal retraining.

19.2 MPASM Assembler

The MPASM assembler is a full-featured universal macro assembler for all PIC MCU's.

The MPASM assembler has a command line interface and a Windows shell. It can be used as a stand-alone application on a Windows 3.x or greater system, or it can be used through MPLAB IDE. The MPASM assembler generates relocatable object files for the MPLINK object linker, Intel[®] standard HEX files, MAP files to detail memory usage and symbol reference, an absolute LST file that contains source lines and generated machine code, and a COD file for debugging.

The MPASM assembler features include:

- Integration into MPLAB IDE projects.
- User-defined macros to streamline assembly code.
- Conditional assembly for multi-purpose source files.
- Directives that allow complete control over the assembly process.

19.3 MPLAB C17 and MPLAB C18 C Compilers

The MPLAB C17 and MPLAB C18 Code Development Systems are complete ANSI 'C' compilers for Microchip's PIC17CXXX and PIC18CXXX family of microcontrollers, respectively. These compilers provide powerful integration capabilities and ease of use not found with other compilers.

For easier source level debugging, the compilers provide symbol information that is compatible with the MPLAB IDE memory display.

19.4 MPLINK Object Linker/ MPLIB Object Librarian

The MPLINK object linker combines relocatable objects created by the MPASM assembler and the MPLAB C17 and MPLAB C18 C compilers. It can also link relocatable objects from pre-compiled libraries, using directives from a linker script.

The MPLIB object librarian is a librarian for pre-compiled code to be used with the MPLINK object linker. When a routine from a library is called from another source file, only the modules that contain that routine will be linked in with the application. This allows large libraries to be used efficiently in many different applications. The MPLIB object librarian manages the creation and modification of library files.

The MPLINK object linker features include:

- Integration with MPASM assembler and MPLAB C17 and MPLAB C18 C compilers.
- Allows all memory areas to be defined as sections to provide link-time flexibility.

The MPLIB object librarian features include:

- Easier linking because single libraries can be included instead of many smaller files.
- Helps keep code maintainable by grouping related modules together.
- Allows libraries to be created and modules to be added, listed, replaced, deleted or extracted.

19.5 MPLAB SIM Software Simulator

The MPLAB SIM software simulator allows code development in a PC-hosted environment by simulating the PIC series microcontrollers on an instruction level. On any given instruction, the data areas can be examined or modified and stimuli can be applied from a file, or user-defined key press, to any of the pins. The execution can be performed in single step, execute until break, or trace mode.

The MPLAB SIM simulator fully supports symbolic debugging using the MPLAB C17 and the MPLAB C18 C compilers and the MPASM assembler. The software simulator offers the flexibility to develop and debug code outside of the laboratory environment, making it an excellent multi-project software development tool.

19.6 MPLAB ICE High Performance Universal In-Circuit Emulator with MPLAB IDE

The MPLAB ICE universal in-circuit emulator is intended to provide the product development engineer with a complete microcontroller design tool set for PIC microcontrollers (MCUs). Software control of the MPLAB ICE in-circuit emulator is provided by the MPLAB Integrated Development Environment (IDE), which allows editing, building, downloading and source debugging from a single environment.

The MPLAB ICE 2000 is a full-featured emulator system with enhanced trace, trigger and data monitoring features. Interchangeable processor modules allow the system to be easily reconfigured for emulation of different processors. The universal architecture of the MPLAB ICE in-circuit emulator allows expansion to support new PIC microcontrollers.

The MPLAB ICE in-circuit emulator system has been designed as a real-time emulation system, with advanced features that are generally found on more expensive development tools. The PC platform and Microsoft® Windows environment were chosen to best make these features available to you, the end user.

19.7 ICEPIC In-Circuit Emulator

The ICEPIC low cost, in-circuit emulator is a solution for the Microchip Technology PIC16C5X, PIC16C6X, PIC16C7X and PIC16CXXX families of 8-bit One-Time-Programmable (OTP) microcontrollers. The modular system can support different subsets of PIC16C5X or PIC16CXXX products through the use of interchangeable personality modules, or daughter boards. The emulator is capable of emulating without target application circuitry being present.

19.8 MPLAB ICD In-Circuit Debugger

Microchip's In-Circuit Debugger, MPLAB ICD, is a powerful, low cost, run-time development tool. This tool is based on the FLASH PIC16F87X and can be used to develop for this and other PIC microcontrollers from the PIC16CXXX family. The MPLAB ICD utilizes the in-circuit debugging capability built into the PIC16F87X. This feature, along with Microchip's In-Circuit Serial Programming™ protocol, offers cost-effective in-circuit FLASH debugging from the graphical user interface of the MPLAB Integrated Development Environment. This enables a designer to develop and debug source code by watching variables, single-stepping and setting break points. Running at full speed enables testing hardware in real-time.

19.9 PRO MATE II Universal Device Programmer

The PRO MATE II universal device programmer is a full-featured programmer, capable of operating in stand-alone mode, as well as PC-hosted mode. The PRO MATE II device programmer is CE compliant.

The PRO MATE II device programmer has programmable VDD and VPP supplies, which allow it to verify programmed memory at VDD min and VDD max for maximum reliability. It has an LCD display for instructions and error messages, keys to enter commands and a modular detachable socket assembly to support various package types. In stand-alone mode, the PRO MATE II device programmer can read, verify, or program PIC MCU devices. It can also set code protection in this mode.

19.10 PICSTART Plus Entry Level Development Programmer

The PICSTART Plus development programmer is an easy-to-use, low cost, prototype programmer. It connects to the PC via a COM (RS-232) port. MPLAB Integrated Development Environment software makes using the programmer simple and efficient.

The PICSTART Plus development programmer supports all PIC devices with up to 40 pins. Larger pin count devices, such as the PIC16C92X and PIC17C76X, may be supported with an adapter socket. The PICSTART Plus development programmer is CE compliant.

19.11 PICDEM 1 Low Cost PIC MCU Demonstration Board

The PICDEM 1 demonstration board is a simple board which demonstrates the capabilities of several of Microchip's microcontrollers. The microcontrollers supported are: PIC16C5X (PIC16C54 to PIC16C58A), PIC16C61, PIC16C62X, PIC16C71, PIC16C8X, PIC17C42, PIC17C43 and PIC17C44. All necessary hardware and software is included to run basic demo programs. The user can program the sample microcontrollers provided with the PICDEM 1 demonstration board on a PRO MATE II device programmer, or a PICSTART Plus development programmer, and easily test firmware. The user can also connect the PICDEM 1 demonstration board to the MPLAB ICE in-circuit emulator and download the firmware to the emulator for testing. A prototype area is available for the user to build some additional hardware and connect it to the microcontroller socket(s). Some of the features include an RS-232 interface, a potentiometer for simulated analog input, push button switches and eight LEDs connected to PORTB.

19.12 PICDEM 2 Low Cost PIC16CXX Demonstration Board

The PICDEM 2 demonstration board is a simple demonstration board that supports the PIC16C62, PIC16C64, PIC16C65, PIC16C73 and PIC16C74 microcontrollers. All the necessary hardware and software is included to run the basic demonstration programs. The user can program the sample microcontrollers provided with the PICDEM 2 demonstration board on a PRO MATE II device programmer, or a PICSTART Plus development programmer, and easily test firmware. The MPLAB ICE in-circuit emulator may also be used with the PICDEM 2 demonstration board to test firmware. A prototype area has been provided to the user for adding additional hardware and connecting it to the microcontroller socket(s). Some of the features include a RS-232 interface, push button switches, a potentiometer for simulated analog input, a serial EEPROM to demonstrate usage of the I²C™ bus and separate headers for connection to an LCD module and a keypad.

PIC17C7XX

19.13 PICDEM 3 Low Cost PIC16CXXX Demonstration Board

The PICDEM 3 demonstration board is a simple demonstration board that supports the PIC16C923 and PIC16C924 in the PLCC package. It will also support future 44-pin PLCC microcontrollers with an LCD Module. All the necessary hardware and software is included to run the basic demonstration programs. The user can program the sample microcontrollers provided with the PICDEM 3 demonstration board on a PRO MATE II device programmer, or a PICSTART Plus development programmer with an adapter socket, and easily test firmware. The MPLAB ICE in-circuit emulator may also be used with the PICDEM 3 demonstration board to test firmware. A prototype area has been provided to the user for adding hardware and connecting it to the microcontroller socket(s). Some of the features include a RS-232 interface, push button switches, a potentiometer for simulated analog input, a thermistor and separate headers for connection to an external LCD module and a keypad. Also provided on the PICDEM 3 demonstration board is a LCD panel, with 4 commons and 12 segments, that is capable of displaying time, temperature and day of the week. The PICDEM 3 demonstration board provides an additional RS-232 interface and Windows software for showing the demultiplexed LCD signals on a PC. A simple serial interface allows the user to construct a hardware demultiplexer for the LCD signals.

19.14 PICDEM 17 Demonstration Board

The PICDEM 17 demonstration board is an evaluation board that demonstrates the capabilities of several Microchip microcontrollers, including PIC17C752, PIC17C756A, PIC17C762 and PIC17C766. All necessary hardware is included to run basic demo programs, which are supplied on a 3.5-inch disk. A programmed sample is included and the user may erase it and program it with the other sample programs using the PRO MATE II device programmer, or the PICSTART Plus development programmer, and easily debug and test the sample code. In addition, the PICDEM 17 demonstration board supports downloading of programs to and executing out of external FLASH memory on board. The PICDEM 17 demonstration board is also usable with the MPLAB ICE in-circuit emulator, or the PICMASTER emulator and all of the sample programs can be run and modified using either emulator. Additionally, a generous prototype area is available for user hardware.

19.15 KEELOQ Evaluation and Programming Tools

KEELOQ evaluation and programming tools support Microchip's HCS Secure Data Products. The HCS evaluation kit includes a LCD display to show changing codes, a decoder to decode transmissions and a programming interface to program test transmitters.

TABLE 19-1: DEVELOPMENT TOOLS FROM MICROCHIP

Tools	PIC12CXXX	PIC14000	PIC16C5X	PIC16C6X	PIC16CXXX	PIC16F62X	PIC16C7X	PIC16C7XX	PIC16C8X	PIC16F8XX	PIC16C9XX	PIC17C4X	PIC17C7XX	PIC18CXX2	24CX/25CX/93CX	HCSXX	MCRFXX	MCP2510
MPLAB® Integrated Development Environment	✓	✓	✓	✓	✓	✓	✓	✓	✓	✓	✓	✓	✓	✓	✓	✓	✓	✓
MPLAB® C17 C Compiler												✓	✓	✓				
MPLAB® C18 C Compiler												✓	✓	✓				
MPASM™ Assembler/ MPLINK™ Object Linker	✓	✓	✓	✓	✓	✓	✓	✓	✓	✓	✓	✓	✓	✓	✓	✓	✓	✓
MPLAB® ICE In-Circuit Emulator	✓	✓	✓	✓	✓	✓	✓	✓	✓	✓	✓	✓	✓	✓	✓	✓	✓	✓
ICEPIC™ In-Circuit Emulator	✓		✓	✓	✓		✓	✓	✓	✓	✓							
MPLAB® ICD In-Circuit Debugger				✓*			✓*			✓								
PICSTART® Plus Entry Level Development Programmer	✓	✓	✓	✓	✓	✓**	✓	✓	✓	✓	✓	✓	✓	✓	✓	✓	✓	✓
PRO MATE® II Universal Device Programmer	✓	✓	✓	✓	✓	✓**	✓	✓	✓	✓	✓	✓	✓	✓	✓	✓	✓	✓
PICDEM™ 1 Demonstration Board			✓		✓		†		✓									
PICDEM™ 2 Demonstration Board							†						✓					
PICDEM™ 3 Demonstration Board											✓							
PICDEM™ 14A Demonstration Board		✓																
PICDEM™ 17 Demonstration Board												✓						
KEELOQ® Evaluation Kit																✓		
KEELOQ® Transponder Kit																✓		
microID™ Programmer's Kit																	✓	
125 kHz microID™ Developer's Kit																	✓	
125 kHz Anticollision microID™ Developer's Kit																	✓	
13.56 MHz Anticollision microID™ Developer's Kit																	✓	
MCP2510 CAN Developer's Kit																	✓	✓

* Contact the Microchip Technology Inc. web site at www.microchip.com for information on how to use the MPLAB® ICD In-Circuit Debugger (DV164001) with PIC16C62, 63, 64, 65, 72, 73, 74, 76, 77.

** Contact Microchip Technology Inc. for availability date.

† Development tool is available on select devices.

PIC17C7XX

NOTES:

20.0 PIC17C7XX ELECTRICAL CHARACTERISTICS

Absolute Maximum Ratings †

Ambient temperature under bias	-55°C to +125°C
Storage temperature	-65°C to +150°C
Voltage on VDD with respect to VSS	0 V to +7.5 V
Voltage on $\overline{\text{MCLR}}$ with respect to VSS (Note 2)	-0.3 V to +14 V
Voltage on RA2 and RA3 with respect to VSS	-0.3 V to +8.5 V
Voltage on all other pins with respect to VSS	-0.3 V to VDD + 0.3 V
Total power dissipation (Note 1)	1.0 W
Maximum current out of VSS pin(s) - total (@ 70°C)	500 mA
Maximum current into VDD pin(s) - total (@ 70°C)	500 mA
Input clamp current, I _{IK} (V _I < 0 or V _I > VDD)	±20 mA
Output clamp current, I _{OK} (V _O < 0 or V _O > VDD)	±20 mA
Maximum output current sunk by any I/O pin (except RA2 and RA3)	35 mA
Maximum output current sunk by RA2 or RA3 pins	60 mA
Maximum output current sourced by any I/O pin	20 mA
Maximum current sunk by PORTA and PORTB (combined)	150 mA
Maximum current sourced by PORTA and PORTB (combined)	100 mA
Maximum current sunk by PORTC, PORTD and PORTE (combined)	150 mA
Maximum current sourced by PORTC, PORTD and PORTE (combined)	100 mA
Maximum current sunk by PORTF and PORTG (combined)	150 mA
Maximum current sourced by PORTF and PORTG (combined)	100 mA
Maximum current sunk by PORTH and PORTJ (combined)	150 mA
Maximum current sourced by PORTH and PORTJ (combined)	100 mA

Note 1: Power dissipation is calculated as follows: $P_{dis} = V_{DD} \times \{I_{DD} - \sum I_{OH}\} + \sum \{(V_{DD} - V_{OH}) \times I_{OH}\} + \sum (V_{OL} \times I_{OL})$

2: Voltage spikes below VSS at the $\overline{\text{MCLR}}$ pin, inducing currents greater than 80 mA, may cause latch-up. Thus, a series resistor of 50-100 Ω should be used when applying a "low" level to the $\overline{\text{MCLR}}$ pin, rather than pulling this pin directly to VSS.

† NOTICE: Stresses above those listed under "Absolute Maximum Ratings" may cause permanent damage to the device. This is a stress rating only and functional operation of the device at those or any other conditions above those indicated in the operation listings of this specification is not implied. Exposure to maximum rating conditions for extended periods may affect device reliability.

PIC17C7XX

FIGURE 20-1: PIC17C7XX-33 VOLTAGE-FREQUENCY GRAPH

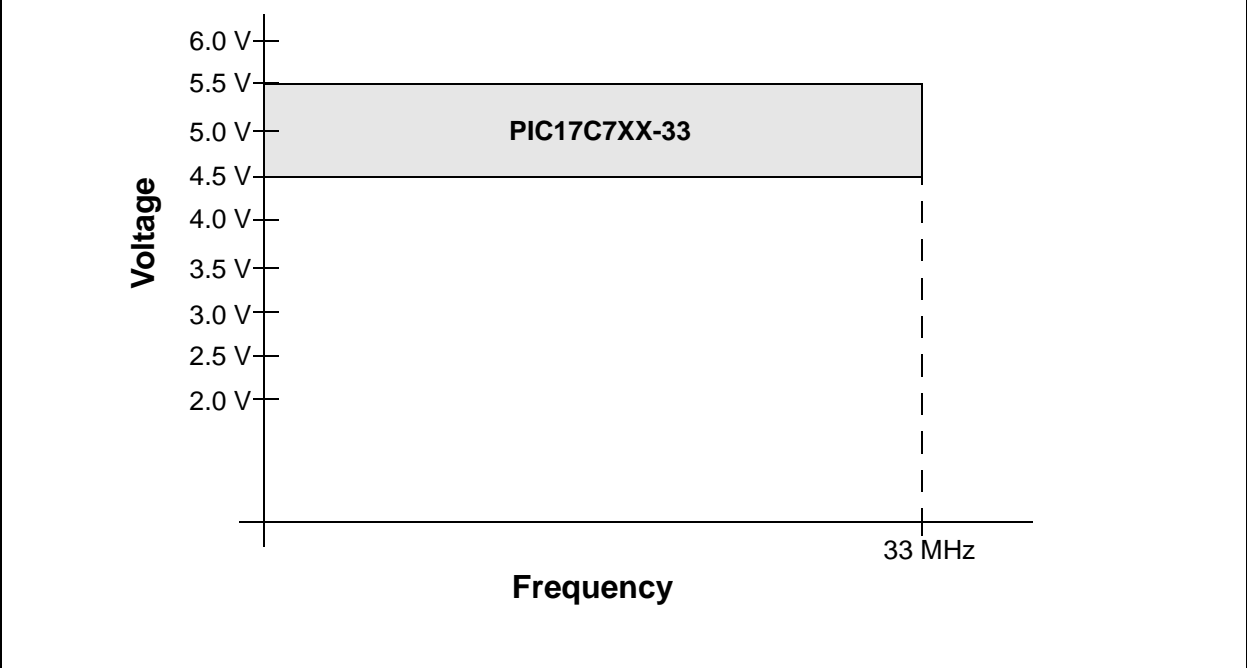

FIGURE 20-2: PIC17C7XX-16 VOLTAGE-FREQUENCY GRAPH

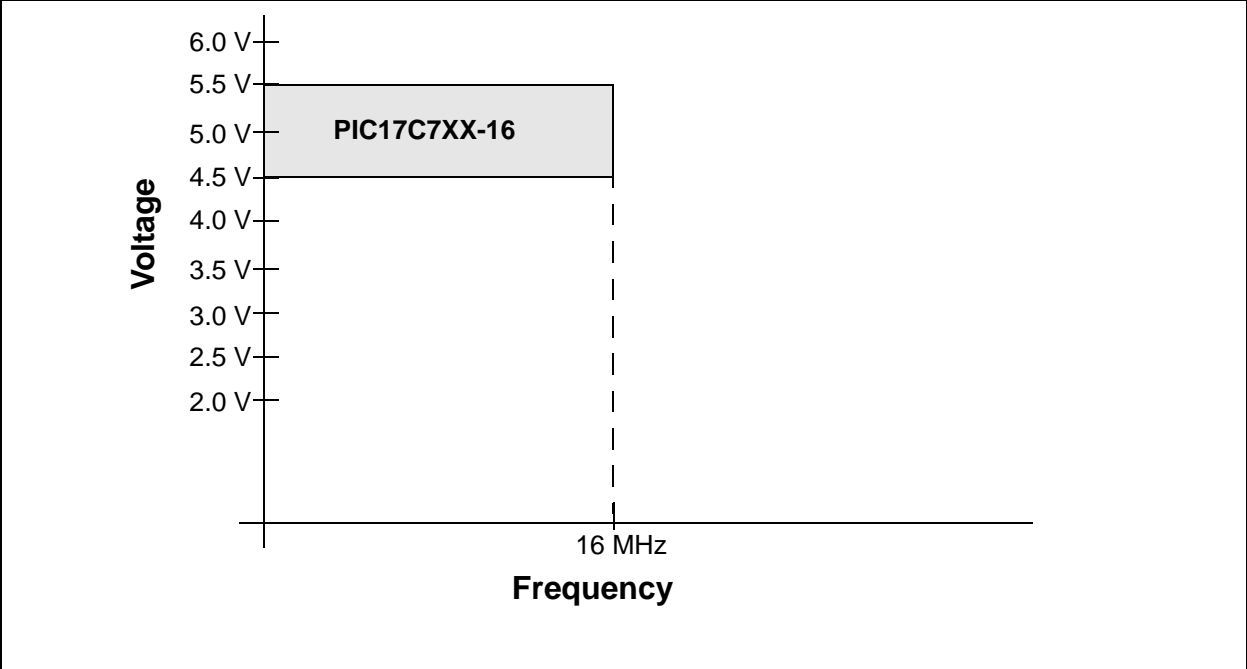

FIGURE 20-3: PIC17LC7XX-08 VOLTAGE-FREQUENCY GRAPH

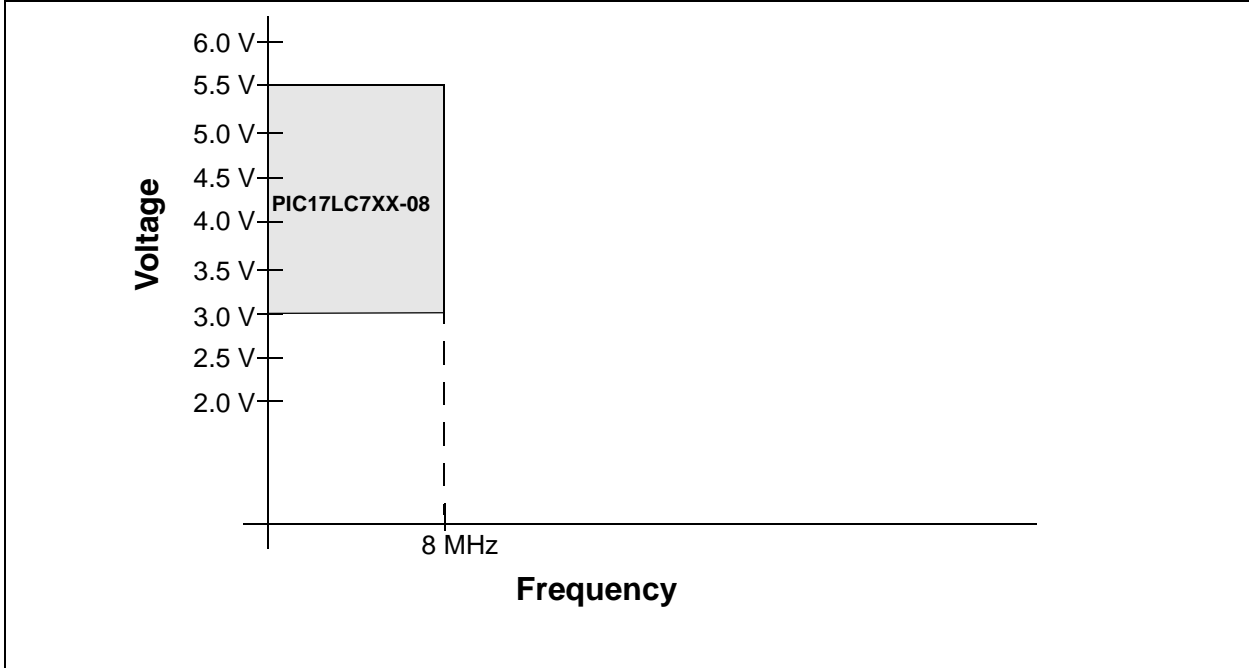
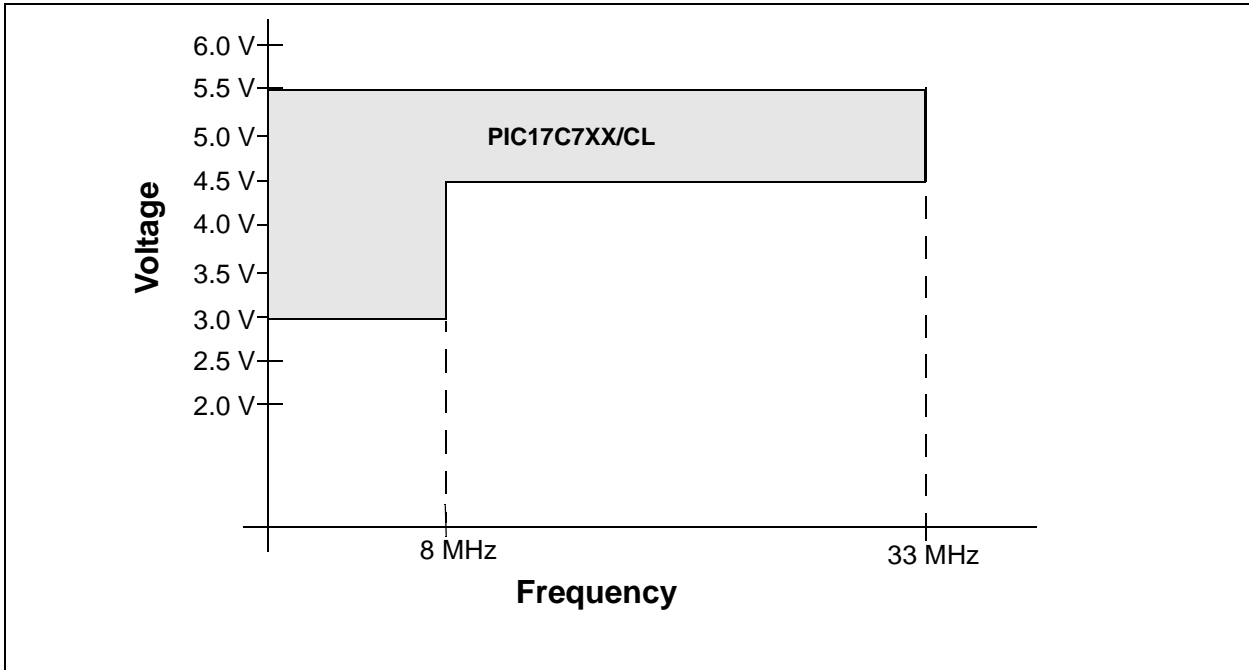

FIGURE 20-4: PIC17C7XX/CL VOLTAGE-FREQUENCY GRAPH



PIC17C7XX

20.1 DC Characteristics

PIC17LC7XX-08 (Commercial, Industrial)		Standard Operating Conditions (unless otherwise stated) Operating temperature -40°C ≤ TA ≤ +85°C for industrial and 0°C ≤ TA ≤ +70°C for commercial					
PIC17C7XX-16 (Commercial, Industrial, Extended) PIC17C7XX-33 (Commercial, Industrial, Extended)		Standard Operating Conditions (unless otherwise stated) Operating temperature -40°C ≤ TA ≤ +125°C for extended -40°C ≤ TA ≤ +85°C for industrial 0°C ≤ TA ≤ +70°C for commercial					
Param. No.	Sym	Characteristic	Min	Typ†	Max	Units	Conditions
D001	VDD	Supply Voltage					
		PIC17LC7XX	3.0	—	5.5	V	
D001		PIC17C7XX-33 PIC17C7XX-16	4.5 VBOR	— —	5.5 5.5	V V	(BOR enabled) (Note 5)
D002	VDR	RAM Data Retention Voltage (Note 1)	1.5	—	—	V	Device in SLEEP mode
D003	VPOR	VDD Start Voltage to ensure internal Power-on Reset signal	—	VSS	—	V	See section on Power-on Reset for details
D004	SVDD	VDD Rise Rate to ensure proper operation					
		PIC17LCXX	0.010	—	—	V/ms	See section on Power-on Reset for details
D004		PIC17CXX	0.085	—	—	V/ms	See section on Power-on Reset for details
D005	VBOR	Brown-out Reset voltage trip point	3.65	—	4.35	V	
D006	VPORTP	Power-on Reset trip point	—	2.2	—	V	VDD = VPORTP

† Data in "Typ" column is at 5V, 25°C unless otherwise stated.

Note 1: This is the limit to which VDD can be lowered in SLEEP mode without losing RAM data.

Note 2: The supply current is mainly a function of the operating voltage and frequency. Other factors such as I/O pin loading and switching rate, oscillator type, internal code execution pattern and temperature also have an impact on the current consumption.

The test conditions for all IDD measurements in active operation mode are:

OSC1 = external square wave, from rail to rail; all I/O pins tri-stated, pulled to VDD or VSS, T0CKI = VDD, MCLR = VDD; WDT disabled.

Current consumed from the oscillator and I/O's driving external capacitive or resistive loads needs to be considered.

For the RC oscillator, the current through the external pull-up resistor (R) can be estimated as:

$V_{DD}/(2 \cdot R)$.

For capacitive loads, the current can be estimated (for an individual I/O pin) as $(C_L \cdot V_{DD}) \cdot f$

CL = Total capacitive load on the I/O pin; f = average frequency the I/O pin switches.

The capacitive currents are most significant when the device is configured for external execution (includes Extended Microcontroller mode).

3: The power-down current in SLEEP mode does not depend on the oscillator type. Power-down current is measured with the part in SLEEP mode, with all I/O pins in hi-impedance state and tied to VDD or VSS.

4: For RC osc configuration, current through REXT is not included. The current through the resistor can be estimated by the formula $I_R = V_{DD}/2R_{EXT}$ (mA) with REXT in kOhm.

5: This is the voltage where the device enters the Brown-out Reset. When BOR is enabled, the device (-16) will operate correctly to this trip point.

PIC17C7XX

Param. No.		Sym	Characteristic	Min	Typ†	Max	Units	Conditions
PIC17LC7XX-08 (Commercial, Industrial)			Standard Operating Conditions (unless otherwise stated) Operating temperature -40°C ≤ TA ≤ +85°C for industrial and 0°C ≤ TA ≤ +70°C for commercial					
PIC17C7XX-16 (Commercial, Industrial, Extended) PIC17C7XX-33 (Commercial, Industrial, Extended)			Standard Operating Conditions (unless otherwise stated) Operating temperature -40°C ≤ TA ≤ +125°C for extended -40°C ≤ TA ≤ +85°C for industrial 0°C ≤ TA ≤ +70°C for commercial					
Param. No.		Sym	Characteristic	Min	Typ†	Max	Units	Conditions
D010		IDD	Supply Current (Note 2)					
			PIC17LC7XX	—	3	6	mA	FOSC = 4 MHz (Note 4)
D010			PIC17C7XX	—	3	6	mA	FOSC = 4 MHz (Note 4)
D011			PIC17LC7XX	—	5	10	mA	FOSC = 8 MHz
D011			PIC17C7XX	—	5	10	mA	FOSC = 8 MHz
D012				—	9	18	mA	FOSC = 16 MHz
D014			PIC17LC7XX	—	85	150	μA	FOSC = 32 kHz, (EC osc configuration)
D015		PIC17C7XX	—	15	30	mA	FOSC = 33 MHz	
D021		IPD	Power-down Current (Note 3)					
			PIC17LC7XX	—	<1	5	μA	VDD = 3.0V, WDT disabled
D021 (commercial, industrial)			PIC17C7XX	—	<1	20	μA	VDD = 5.5V, WDT disabled
D021A (extended)			—	2	20	μA	VDD = 5.5V, WDT disabled	
D023		ΔIBOR	Module Differential Current					
			BOR circuitry	—	75	150	μA	VDD = 4.5V, BODEN enabled
D024			Watchdog Timer	—	10	35	μA	VDD = 5.5V
D026		ΔIAD	A/D converter	—	1	—	μA	VDD = 5.5V, A/D not converting

† Data in "Typ" column is at 5V, 25°C unless otherwise stated.

Note 1: This is the limit to which VDD can be lowered in SLEEP mode without losing RAM data.

2: The supply current is mainly a function of the operating voltage and frequency. Other factors such as I/O pin loading and switching rate, oscillator type, internal code execution pattern and temperature also have an impact on the current consumption.

The test conditions for all IDD measurements in active operation mode are:

OSC1 = external square wave, from rail to rail; all I/O pins tri-stated, pulled to VDD or VSS, T0CKI = VDD, MCLR = VDD; WDT disabled.

Current consumed from the oscillator and I/O's driving external capacitive or resistive loads needs to be considered.

For the RC oscillator, the current through the external pull-up resistor (R) can be estimated as:
 $V_{DD}/(2 \cdot R)$.

For capacitive loads, the current can be estimated (for an individual I/O pin) as $(C_L \cdot V_{DD}) \cdot f$

C_L = Total capacitive load on the I/O pin; f = average frequency the I/O pin switches.

The capacitive currents are most significant when the device is configured for external execution (includes Extended Microcontroller mode).

3: The power-down current in SLEEP mode does not depend on the oscillator type. Power-down current is measured with the part in SLEEP mode, with all I/O pins in hi-impedance state and tied to VDD or VSS.

4: For RC osc configuration, current through REXT is not included. The current through the resistor can be estimated by the formula $I_R = V_{DD}/2R_{EXT}$ (mA) with REXT in kOhm.

5: This is the voltage where the device enters the Brown-out Reset. When BOR is enabled, the device (-16) will operate correctly to this trip point.

PIC17C7XX

20.2 DC Characteristics: PIC17C7XX-16 (Commercial, Industrial, Extended) PIC17C7XX-33 (Commercial, Industrial, Extended) PIC17LC7XX-08 (Commercial, Industrial)

Standard Operating Conditions (unless otherwise stated)							
DC CHARACTERISTICS							
Operating temperature							
-40°C ≤ TA ≤ +125°C for extended							
-40°C ≤ TA ≤ +85°C for industrial							
0°C ≤ TA ≤ +70°C for commercial							
Operating voltage VDD range as described in Section 20.1							
Param. No.	Sym	Characteristic	Min	Typ†	Max	Units	Conditions
Input Low Voltage							
D030	VIL	I/O ports with TTL buffer (Note 6)	Vss	–	0.8	V	4.5V ≤ VDD ≤ 5.5V
D031		with Schmitt Trigger buffer RA2, RA3	Vss	–	0.2VDD	V	3.0V ≤ VDD ≤ 4.5V
D032		All others	Vss	–	0.3VDD	V	I ² C compliant
D033		MCLR, OSC1 (in EC and RC mode)	Vss	–	0.2VDD	V	(Note 1)
		OSC1 (in XT, and LF mode)	–	0.5VDD	–	V	
Input High Voltage							
D040	VIH	I/O ports with TTL buffer (Note 6)	2.0	–	VDD	V	4.5V ≤ VDD ≤ 5.5V
D041		with Schmitt Trigger buffer RA2, RA3	1 + 0.2VDD	–	VDD	V	3.0V ≤ VDD ≤ 4.5V
D042		All others	0.7VDD	–	VDD	V	I ² C compliant
D043		MCLR	0.8VDD	–	VDD	V	(Note 1)
D043		OSC1 (XT, and LF mode)	–	0.5VDD	–	V	
D050	VHYS	Hysteresis of Schmitt Trigger Inputs	0.15VDD	–	–	V	

† Data in “Typ” column is at 5V, 25°C unless otherwise stated.

- Note 1:** In RC oscillator configuration, the OSC1/CLKIN pin is a Schmitt Trigger input. It is not recommended that the PIC17CXXX devices be driven with external clock in RC mode.
- 2:** The leakage current on the MCLR pin is strongly dependent on the applied voltage level. Higher leakage current may be measured at different input voltages.
- 3:** Negative current is defined as current sourced by the pin.
- 4:** These specifications are for the programming of the on-chip program memory EPROM through the use of the table write instructions. The complete programming specifications can be found in: PIC17C7XX Programming Specifications (Literature number DS TBD).
- 5:** The MCLR/VPP pin may be kept in this range at times other than programming, but is not recommended.
- 6:** For TTL buffers, the better of the two specifications may be used.

PIC17C7XX

Standard Operating Conditions (unless otherwise stated)							
Operating temperature							
DC CHARACTERISTICS							
-40°C ≤ TA ≤ +125°C for extended							
-40°C ≤ TA ≤ +85°C for industrial							
0°C ≤ TA ≤ +70°C for commercial							
Operating voltage VDD range as described in Section 20.1							
Param. No.	Sym	Characteristic	Min	Typ†	Max	Units	Conditions
D060	IIL	Input Leakage Current (Notes 2, 3) I/O ports (except RA2, RA3)	–	–	±1	μA	VSS ≤ VPIN ≤ VDD, I/O Pin (in digital mode) at hi-impedance PORTB weak pull-ups disabled
D061		$\overline{\text{MCLR}}$, TEST	–	–	±2	μA	VPIN = VSS or VPIN = VDD
D062		RA2, RA3	–	–	±2	μA	VSS ≤ VRA2, VRA3 ≤ 12V
D063		OSC1 (EC, RC modes)	–	–	±1	μA	VSS ≤ VPIN ≤ VDD
D063B		OSC1 (XT, LF modes)	–	–	VPIN	μA	RF ≥ 1 MΩ
D064		$\overline{\text{MCLR}}$, TEST	–	–	25	μA	VMCLR = VPP = 12V (when not programming)
D070	IPURB	PORTB Weak Pull-up Current	85	130	260	μA	VPIN = VSS, $\overline{\text{RBPU}} = 0$ 4.5V ≤ VDD ≤ 5.5V
D080	VOL	Output Low Voltage I/O ports	–	–	0.1VDD	V	IOL = VDD/1.250 mA 4.5V ≤ VDD ≤ 5.5V
D081		with TTL buffer	–	–	0.1VDD	V	VDD = 3.0V
D082		RA2 and RA3	–	–	0.4	V	IOL = 6 mA, VDD = 4.5V (Note 6)
D083		OSC2/CLKOUT	–	–	3.0	V	IOL = 60.0 mA, VDD = 5.5V
D084		(RC and EC osc modes)	–	–	0.6	V	IOL = 60.0 mA, VDD = 4.5V
D090	VOH	Output High Voltage (Note 3) I/O ports (except RA2 and RA3)	0.9VDD	–	–	V	IOH = -VDD/2.5 mA 4.5V ≤ VDD ≤ 5.5V
D091		with TTL buffer	0.9VDD	–	–	V	VDD = 3.0V
D093		OSC2/CLKOUT	2.4	–	–	V	IOH = -6.0 mA, VDD = 4.5V (Note 6)
D094		(RC and EC osc modes)	2.4	–	–	V	IOH = -5 mA, VDD = 4.5V
			0.9VDD	–	–	V	IOH = -VDD/5 mA (PIC17LC7XX only)

† Data in "Typ" column is at 5V, 25°C unless otherwise stated.

- Note 1:** In RC oscillator configuration, the OSC1/CLKIN pin is a Schmitt Trigger input. It is not recommended that the PIC17CXXX devices be driven with external clock in RC mode.
- 2:** The leakage current on the $\overline{\text{MCLR}}$ pin is strongly dependent on the applied voltage level. Higher leakage current may be measured at different input voltages.
- 3:** Negative current is defined as current sourced by the pin.
- 4:** These specifications are for the programming of the on-chip program memory EPROM through the use of the table write instructions. The complete programming specifications can be found in: PIC17C7XX Programming Specifications (Literature number DS TBD).
- 5:** The $\overline{\text{MCLR}}$ /VPP pin may be kept in this range at times other than programming, but is not recommended.
- 6:** For TTL buffers, the better of the two specifications may be used.

PIC17C7XX

Standard Operating Conditions (unless otherwise stated)							
DC CHARACTERISTICS							
Operating temperature							
-40°C ≤ TA ≤ +125°C for extended							
-40°C ≤ TA ≤ +85°C for industrial							
0°C ≤ TA ≤ +70°C for commercial							
Operating voltage VDD range as described in Section 20.1							
Param. No.	Sym	Characteristic	Min	Typ†	Max	Units	Conditions
D150	VOD	Open Drain High Voltage	–	–	8.5	V	RA2 and RA3 pins only pulled up to externally applied voltage
D100	Cosc2	Capacitive Loading Specs on Output Pins OSC2/CLKOUT pin	–	–	25	pF	In EC or RC osc modes, when OSC2 pin is outputting CLKOUT. External clock is used to drive OSC1.
D101	CIO	All I/O pins and OSC2 (in RC mode)	–	–	50	pF	
D102	CAD	System Interface Bus (PORTC, PORTD and PORTE)	–	–	50	pF	
Internal Program Memory Programming Specs (Note 4)							
D110	VPP	Voltage on MCLR/VPP pin	12.75	–	13.25	V	(Note 5)
D111	VDDP	Supply voltage during programming	4.75	5.0	5.25	V	
D112	IPP	Current into MCLR/VPP pin	–	25	50	mA	Terminated via internal/external interrupt or a RESET
D113	IDDP	Supply current during programming	–	–	30	mA	
D114	TPROG	Programming pulse width	100	–	1000	ms	

† Data in “Typ” column is at 5V, 25°C unless otherwise stated.

Note 1: In RC oscillator configuration, the OSC1/CLKIN pin is a Schmitt Trigger input. It is not recommended that the PIC17CXXX devices be driven with external clock in RC mode.

2: The leakage current on the MCLR pin is strongly dependent on the applied voltage level. Higher leakage current may be measured at different input voltages.

3: Negative current is defined as current sourced by the pin.

4: These specifications are for the programming of the on-chip program memory EPROM through the use of the table write instructions. The complete programming specifications can be found in: PIC17C7XX Programming Specifications (Literature number DS TBD).

5: The MCLR/VPP pin may be kept in this range at times other than programming, but is not recommended.

6: For TTL buffers, the better of the two specifications may be used.

Note 1: When using the Table Write for internal programming, the device temperature must be less than 40°C.

2: For In-Circuit Serial Programming (ICSP™), refer to the device programming specification.

20.3 Timing Parameter Symbology

The timing parameter symbols have been created following one of the following formats:

1. TppS2ppS
2. TppS
3. Tcc:ST (I²C specifications only)
4. Ts (I²C specifications only)

T			
F	Frequency	T	Time

Lowercase symbols (pp) and their meanings:

pp			
ad	Address/Data	ost	Oscillator Start-Up Timer
al	ALE	pwrt	Power-Up Timer
cc	Capture1 and Capture2	rb	PORTB
ck	CLKOUT or clock	rd	\overline{RD}
dt	Data in	rw	\overline{RD} or \overline{WR}
in	INT pin	t0	T0CKI
io	I/O port	t123	TCLK12 and TCLK3
mc	\overline{MCLR}	wdt	Watchdog Timer
oe	\overline{OE}	wr	\overline{WR}
os	OSC1		

Uppercase symbols and their meanings:

S			
D	Driven	L	Low
E	Edge	P	Period
F	Fall	R	Rise
H	High	V	Valid
I	Invalid (Hi-impedance)	Z	Hi-impedance

PIC17C7XX

FIGURE 20-5: PARAMETER MEASUREMENT INFORMATION

All timings are measured between high and low measurement points as indicated below.

INPUT LEVEL CONDITIONS

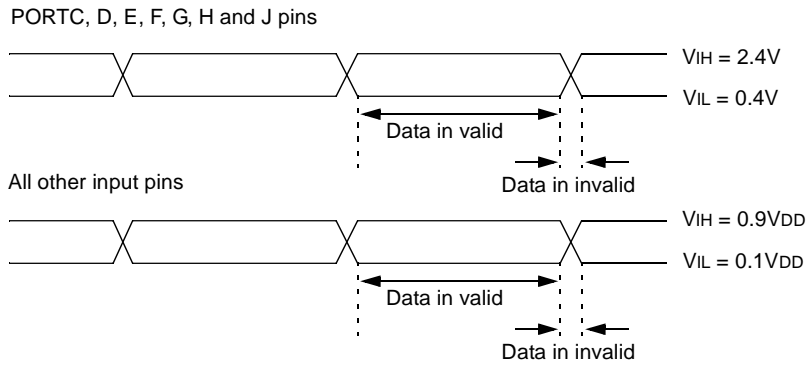

OUTPUT LEVEL CONDITIONS

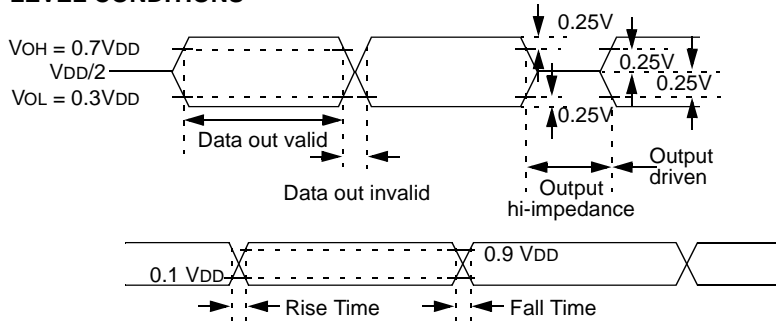

LOAD CONDITIONS

Load Condition 1

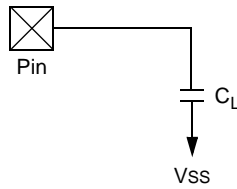

$50 \text{ pF} \leq C_L$

20.4 Timing Diagrams and Specifications

FIGURE 20-6: EXTERNAL CLOCK TIMING

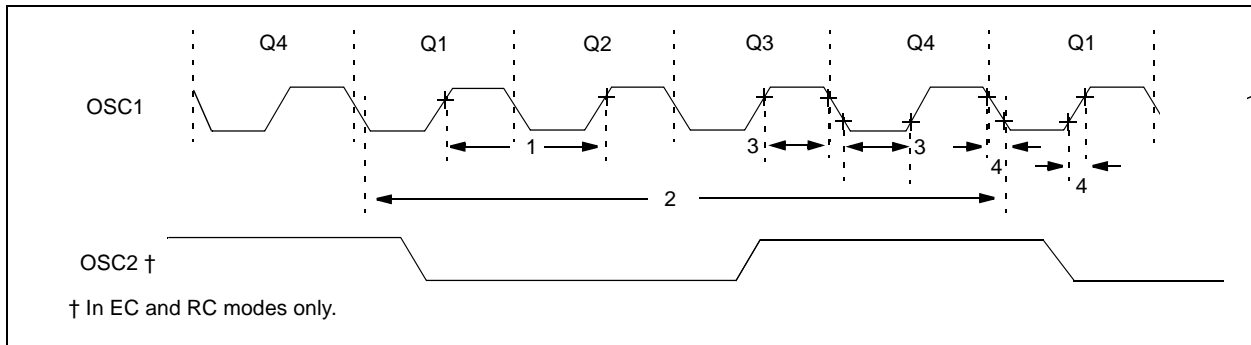

TABLE 20-1: EXTERNAL CLOCK TIMING REQUIREMENTS

Param No.	Sym	Characteristic	Min	Typ†	Max	Units	Conditions
	FOSC	External CLKIN Frequency (Note 1)	DC	—	8	MHz	EC osc mode - 08 devices (8 MHz devices)
			DC	—	16	MHz	- 16 devices (16 MHz devices)
			DC	—	33	MHz	- 33 devices (33 MHz devices)
		Oscillator Frequency (Note 1)	DC	—	4	MHz	RC osc mode
			2	—	8	MHz	XT osc mode - 08 devices (8 MHz devices)
			2	—	16	MHz	- 16 devices (16 MHz devices)
			2	—	33	MHz	- 33 devices (33 MHz devices)
			DC	—	2	MHz	LF osc mode
1	TOSC	External CLKIN Period (Note 1)	125	—	—	ns	EC osc mode - 08 devices (8 MHz devices)
			62.5	—	—	ns	- 16 devices (16 MHz devices)
			30.3	—	—	ns	- 33 devices (33 MHz devices)
		Oscillator Period (Note 1)	250	—	—	ns	RC osc mode
			125	—	1,000	ns	XT osc mode - 08 devices (8 MHz devices)
			62.5	—	1,000	ns	- 16 devices (16 MHz devices)
			30.3	—	1,000	ns	- 33 devices (33 MHz devices)
			500	—	—	ns	LF osc mode
2	Tcy	Instruction Cycle Time (Note 1)	121.2	4/FOSC	DC	ns	
3	TosL, TosH	Clock in (OSC1) High or Low Time	10	—	—	ns	EC oscillator
4	TosR, TosF	Clock in (OSC1) Rise or Fall Time	—	—	5	ns	EC oscillator

† Data in "Typ" column is at 5V, 25°C unless otherwise stated.

Note 1: Instruction cycle period (Tcy) equals four times the input oscillator time base period. All specified values are based on characterization data for that particular oscillator type under standard operating conditions with the device executing code. Exceeding these specified limits may result in an unstable oscillator operation and/or higher than expected current consumption. All devices are tested to operate at "min." values with an external clock applied to the OSC1/CLKIN pin. When an external clock input is used, the "max." cycle time limit is "DC" (no clock) for all devices.

PIC17C7XX

FIGURE 20-7: CLKOUT AND I/O TIMING

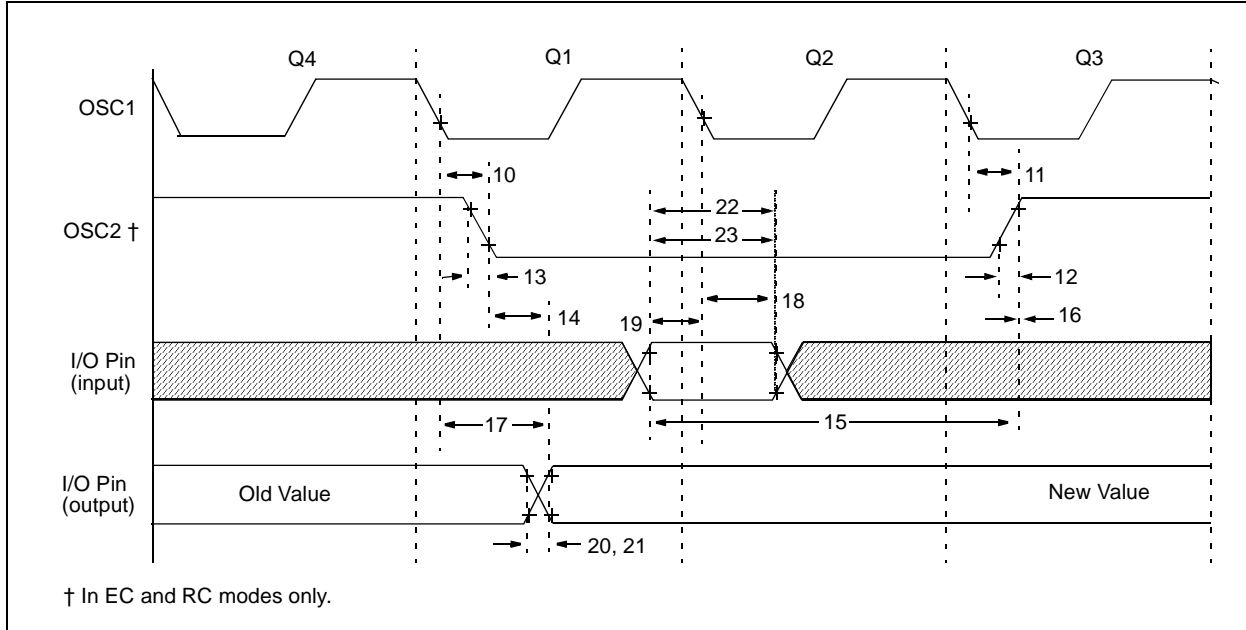

TABLE 20-2: CLKOUT AND I/O TIMING REQUIREMENTS

Param No.	Sym	Characteristic	Min	Typ†	Max	Units	Conditions
10	TosL2ckL	OSC1↓ to CLKOUT↓	—	15	30	ns	(Note 1)
11	TosL2ckH	OSC1↓ to CLKOUT↑	—	15	30	ns	(Note 1)
12	TckR	CLKOUT rise time	—	5	15	ns	(Note 1)
13	TckF	CLKOUT fall time	—	5	15	ns	(Note 1)
14	TckH2ioV	CLKOUT ↑ to Port out valid	—	—	0.5T _{cy} + 20	ns	(Note 1)
15	TioV2ckH	Port in valid before CLKOUT↑	0.25T _{cy} + 25	—	—	ns	(Note 1)
16	TckH2ioI	Port in hold after CLKOUT↑	0	—	—	ns	(Note 1)
17	TosL2ioV	OSC1↓ (Q1 cycle) to Port out valid	—	—	100	ns	
18	TosL2ioI	OSC1↓ (Q2 cycle) to Port input invalid (I/O in hold time)	0	—	—	ns	
19	TioV2osL	Port input valid to OSC1↓ (I/O in setup time)	30	—	—	ns	
20	TioR	Port output rise time	—	10	35	ns	
21	TioF	Port output fall time	—	10	35	ns	
22	TinHL	INT pin high or low time	25	—	—	ns	
23	TrbHL	RB7:RB0 change INT high or low time	25	—	—	ns	

† Data in "Typ" column is at 5V, 25°C unless otherwise stated. These parameters are for design guidance only and are not tested.

Note 1: Measurements are taken in EC mode, where CLKOUT output is 4 x T_{osc}.

FIGURE 20-8: RESET, WATCHDOG TIMER, OSCILLATOR START-UP TIMER, POWER-UP TIMER, AND BROWN-OUT RESET TIMING

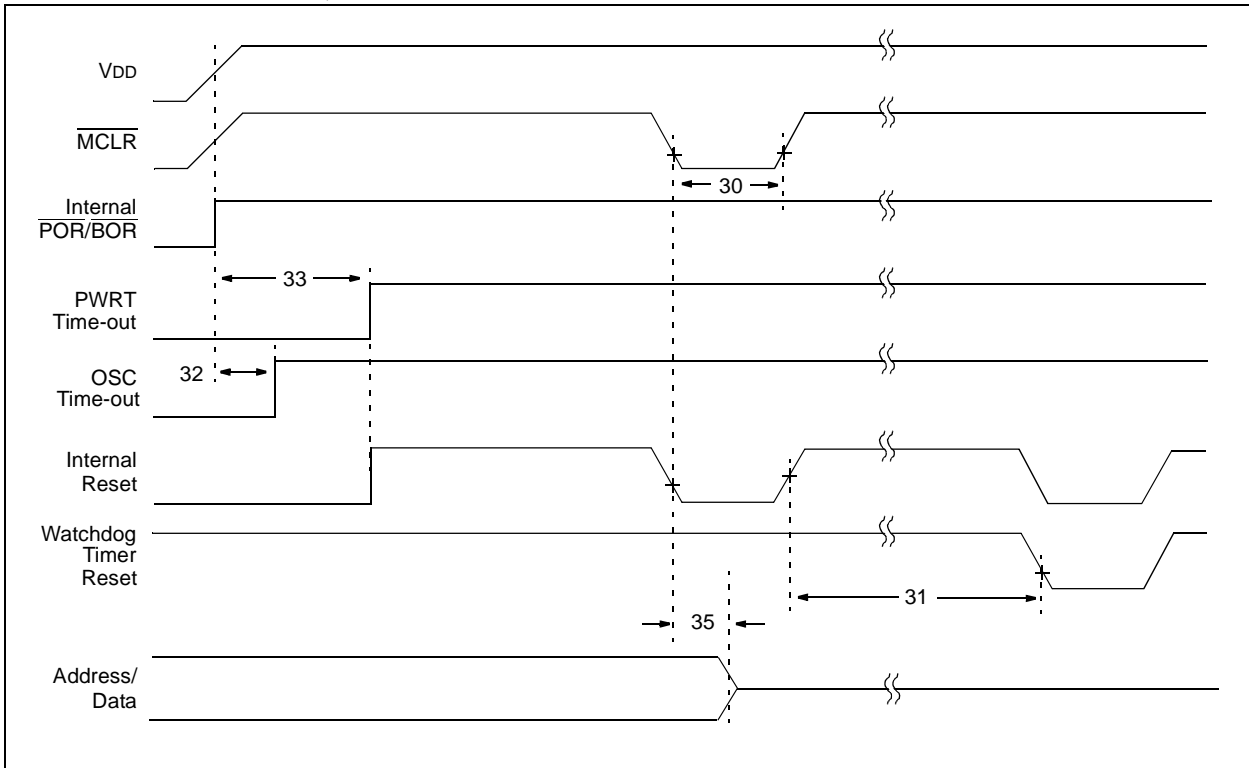

TABLE 20-3: RESET, WATCHDOG TIMER, OSCILLATOR START-UP TIMER, POWER-UP TIMER, AND BROWN-OUT RESET REQUIREMENTS

Param. No.	Sym	Characteristic	Min	Typ†	Max	Units	Conditions	
30	Tmcl	MCLR Pulse Width (low)	100	—	—	ns	VDD = 5V	
31	TWDT	Watchdog Timer Time-out Period (Postscale = 1)	5	12	25	ms	VDD = 5V	
32	ToST	Oscillation Start-up Timer Period	—	1024Tosc	—	ms	Tosc = OSC1 period	
33	TPWRT	Power-up Timer Period	40	96	200	ms	VDD = 5V	
34	TIOZ	MCLR to I/O hi-impedance	100	—	—	ns	Depends on pin load	
35	Tmcl2adl	MCLR to System Interface bus (AD15:AD0) invalid	PIC17C7XX	—	—	100	ns	
			PIC17LC7XX	—	—	120	ns	
36	TBOR	Brown-out Reset Pulse Width (low)	100	—	—	ns	VDD within VBOR limits (parameter D005)	

† Data in "Typ" column is at 5V, 25°C unless otherwise stated.

PIC17C7XX

FIGURE 20-9: TIMER0 EXTERNAL CLOCK TIMINGS

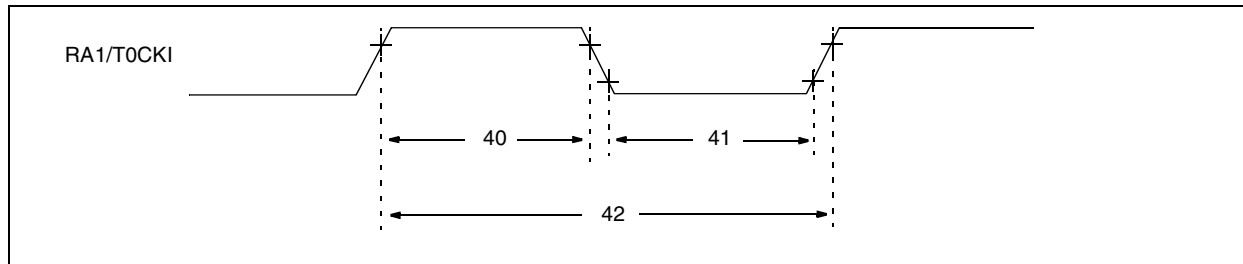

TABLE 20-4: TIMER0 EXTERNAL CLOCK REQUIREMENTS

Param No.	Sym	Characteristic	Min	Typ†	Max	Units	Conditions
40	Tt0H	T0CKI High Pulse Width	No Prescaler	$0.5T_{CY} + 20$	—	—	ns
		With Prescaler	10	—	—	ns	
41	Tt0L	T0CKI Low Pulse Width	No Prescaler	$0.5T_{CY} + 20$	—	—	ns
		With Prescaler	10	—	—	ns	
42	Tt0P	T0CKI Period	Greater of: $20 \text{ ns or } \frac{T_{CY} + 40}{N}$	—	—	ns	N = prescale value (1, 2, 4, ..., 256)

† Data in "Typ" column is at 5V, 25°C unless otherwise stated.

FIGURE 20-10: TIMER1, TIMER2 AND TIMER3 EXTERNAL CLOCK TIMINGS

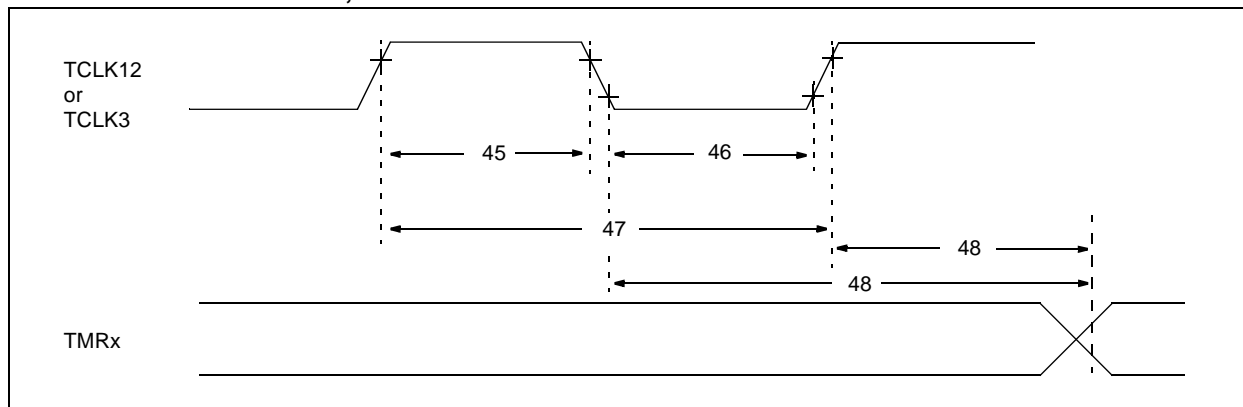

TABLE 20-5: TIMER1, TIMER2 AND TIMER3 EXTERNAL CLOCK REQUIREMENTS

Param No.	Sym	Characteristic	Min	Typ†	Max	Units	Conditions
45	Tt123H	TCLK12 and TCLK3 high time	$0.5T_{CY} + 20$	—	—	ns	
46	Tt123L	TCLK12 and TCLK3 low time	$0.5T_{CY} + 20$	—	—	ns	
47	Tt123P	TCLK12 and TCLK3 input period	$\frac{T_{CY} + 40}{N}$	—	—	ns	N = prescale value (1, 2, 4, 8)
48	TckE2tmrl	Delay from selected External Clock Edge to Timer increment	$2T_{osc}$	—	$6T_{osc}$	—	

† Data in "Typ" column is at 5V, 25°C unless otherwise stated.

FIGURE 20-11: CAPTURE TIMINGS

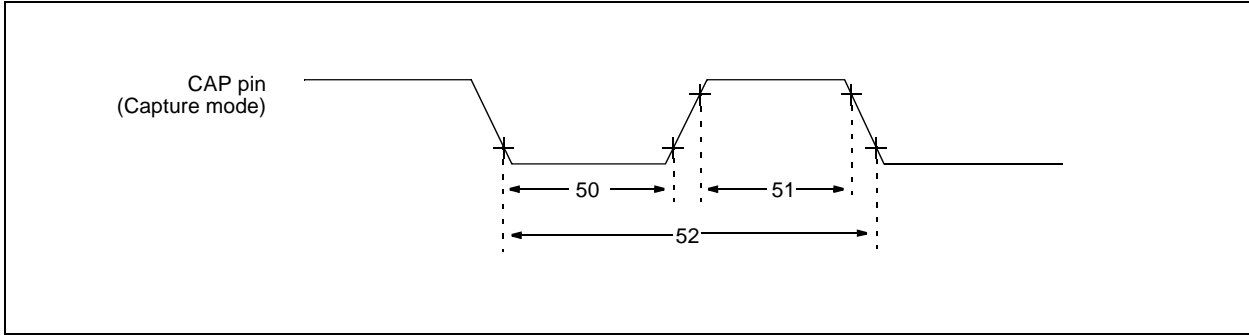

TABLE 20-6: CAPTURE REQUIREMENTS

Param No.	Sym	Characteristic	Min	Typ †	Max	Units	Conditions
50	TccL	Capture pin input low time	10	—	—	ns	
51	TccH	Capture pin input high time	10	—	—	ns	
52	TccP	Capture pin input period	$\frac{2T_{CY}}{N}$	—	—	ns	N = prescale value (4 or 16)

† Data in "Typ" column is at 5V, 25°C unless otherwise stated.

FIGURE 20-12: PWM TIMINGS

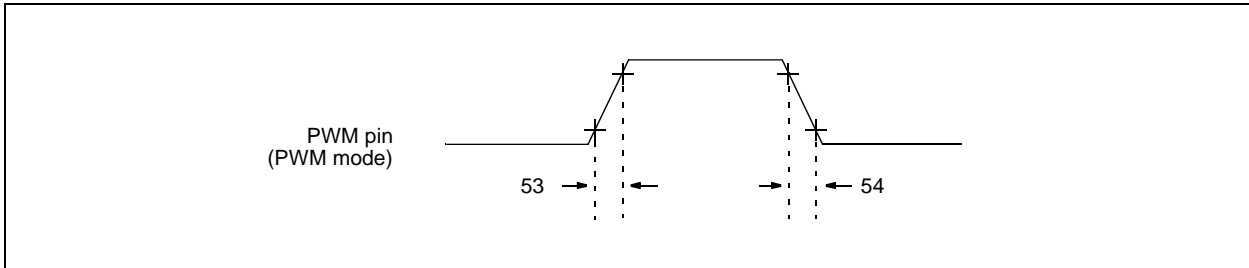

TABLE 20-7: PWM REQUIREMENTS

Param No.	Sym	Characteristic	Min	Typ †	Max	Units	Conditions
53	TccR	PWM pin output rise time	—	10	35	ns	
54	TccF	PWM pin output fall time	—	10	35	ns	

† Data in "Typ" column is at 5V, 25°C unless otherwise stated.

PIC17C7XX

FIGURE 20-13: SPI MASTER MODE TIMING (CKE = 0)

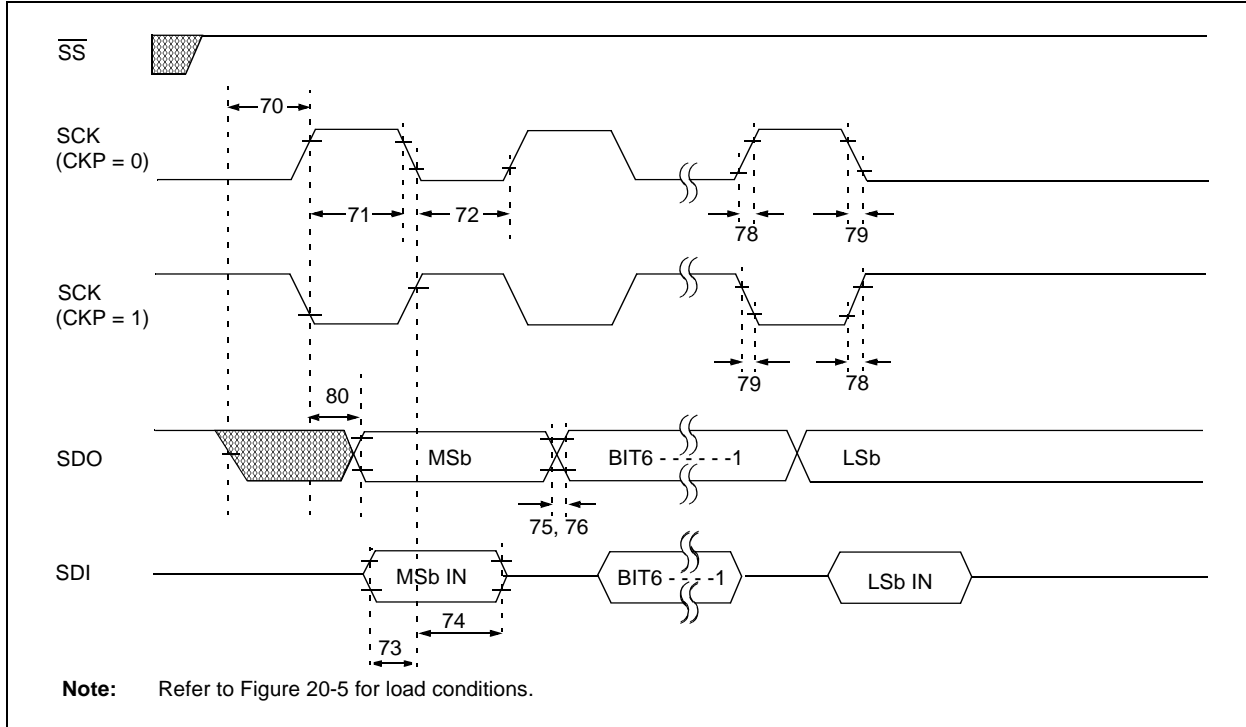

TABLE 20-8: SPI MODE REQUIREMENTS (MASTER MODE, CKE = 0)

Param. No.	Symbol	Characteristic	Min	Typ†	Max	Units	Conditions
70	Tssl2sch, Tssl2scl	$\overline{SS}\downarrow$ to SCK \downarrow or SCK \uparrow input	Tcy	—	—	ns	
71	TschH	SCK input high time (Slave mode)	Continuous	1.25Tcy + 30	—	—	ns
71A			Single Byte	40	—	—	ns
72	TsclL	SCK input low time (Slave mode)	Continuous	1.25Tcy + 30	—	—	ns
72A			Single Byte	40	—	—	ns
73	TdiV2sch, TdiV2scl	Setup time of SDI data input to SCK edge	100	—	—	ns	
73A	Tb2b	Last clock edge of Byte1 to the 1st clock edge of Byte2	1.5Tcy + 40	—	—	ns	(Note 1)
74	Tsch2diL, TscL2diL	Hold time of SDI data input to SCK edge	100	—	—	ns	
75	TdoR	SDO data output rise time	—	10	25	ns	
76	TdoF	SDO data output fall time	—	10	25	ns	
78	TscR	SCK output rise time (Master mode)	—	10	25	ns	
79	TscF	SCK output fall time (Master mode)	—	10	25	ns	
80	Tsch2doV, TscL2doV	SDO data output valid after SCK edge	—	—	50	ns	

† Data in "Typ" column is at 5V, 25°C unless otherwise stated.

Note 1: Specification 73A is only required if specifications 71A and 72A are used.

FIGURE 20-14: SPI MASTER MODE TIMING (CKE = 1)

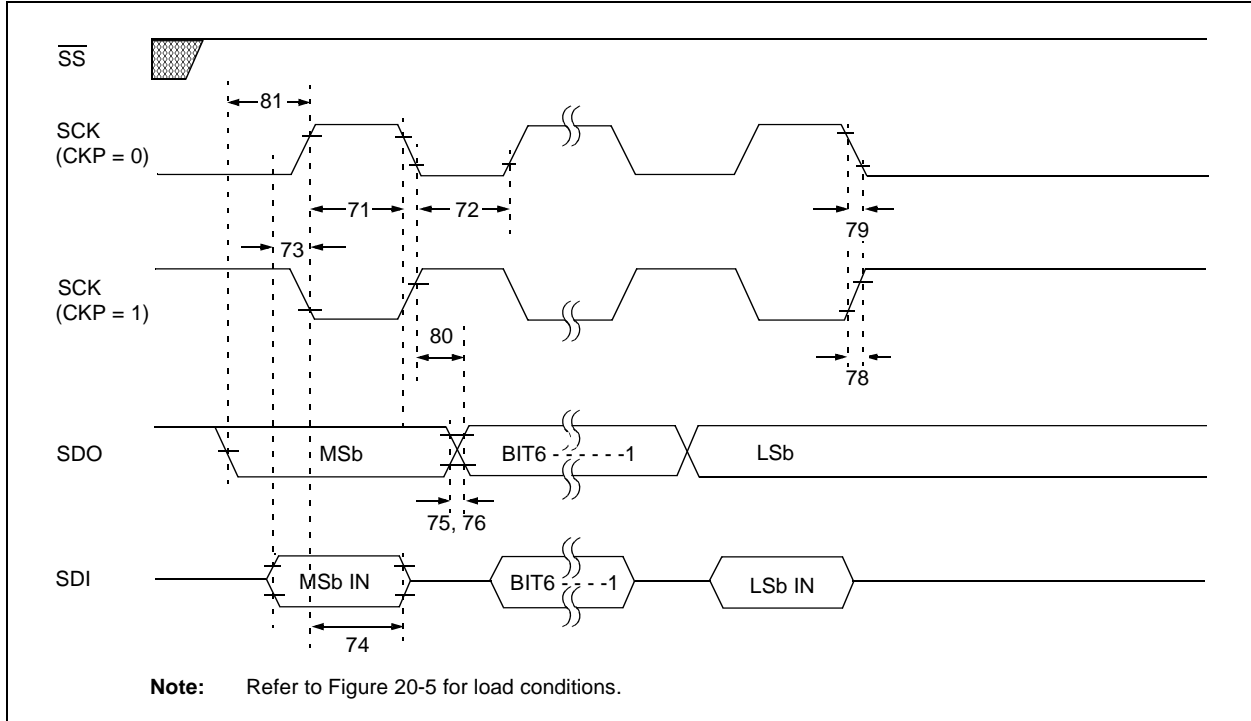

TABLE 20-9: SPI MODE REQUIREMENTS (MASTER MODE, CKE = 1)

Param. No.	Symbol	Characteristic	Min	Typ†	Max	Units	Conditions
71	Tsch	SCK input high time (Slave mode)	Continuous	1.25Tcy + 30	—	—	ns
71A			Single Byte	40	—	—	ns (Note 1)
72	Tscl	SCK input low time (Slave mode)	Continuous	1.25 Tcy + 30	—	—	ns
72A			Single Byte	40	—	—	ns (Note 1)
73	TdiV2sch, TdiV2scl	Setup time of SDI data input to SCK edge	100	—	—	ns	
73A	TB2B	Last clock edge of Byte1 to the 1st clock edge of Byte2	1.5Tcy + 40	—	—	ns	(Note 1)
74	Tsch2diL, TscL2diL	Hold time of SDI data input to SCK edge	100	—	—	ns	
75	TdoR	SDO data output rise time	—	10	25	ns	
76	TdoF	SDO data output fall time	—	10	25	ns	
78	TscR	SCK output rise time (Master mode)	—	10	25	ns	
79	TscF	SCK output fall time (Master mode)	—	10	25	ns	
80	Tsch2doV, TscL2doV	SDO data output valid after SCK edge	—	—	50	ns	
81	TdoV2sch, TdoV2scl	SDO data output setup to SCK edge	Tcy	—	—	ns	

† Data in "Typ" column is at 5V, 25°C unless otherwise stated.

Note 1: Specification 73A is only required if specifications 71A and 72A are used.

PIC17C7XX

FIGURE 20-15: SPI SLAVE MODE TIMING (CKE = 0)

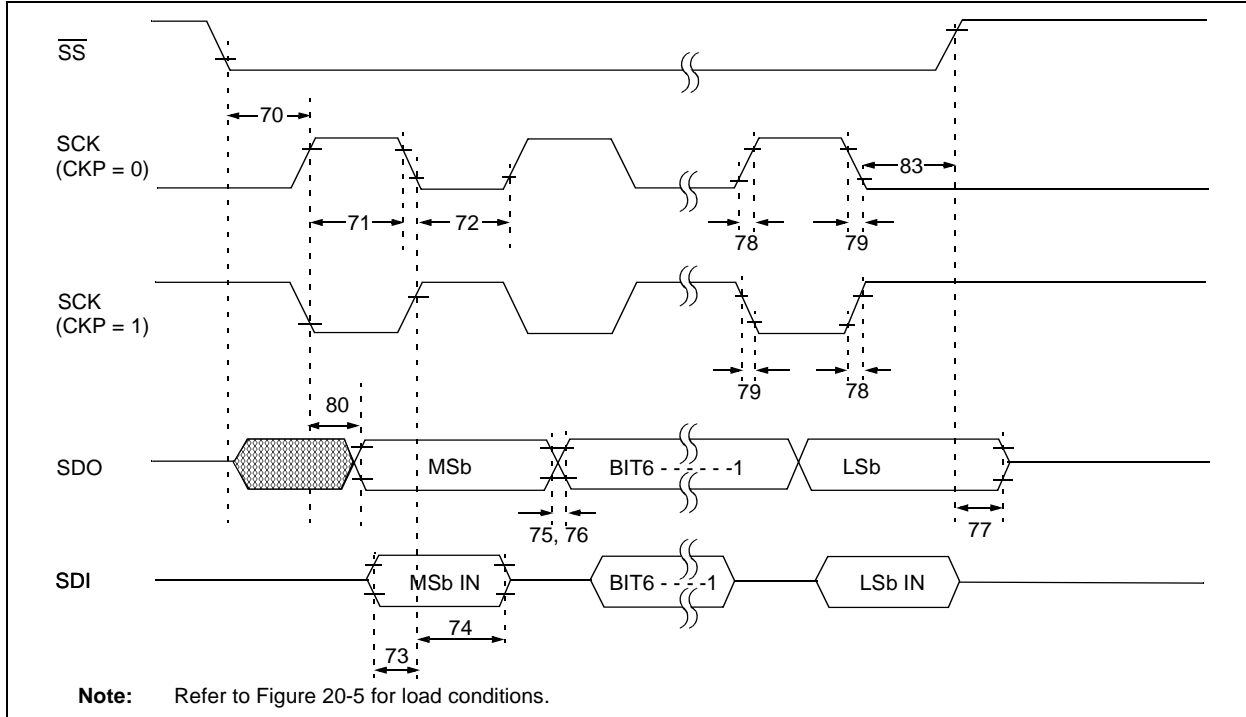

TABLE 20-10: SPI MODE REQUIREMENTS (SLAVE MODE TIMING, CKE = 0)

Param. No.	Symbol	Characteristic	Min	Typ†	Max	Units	Conditions
70	TssL2scH, TssL2scL	$\overline{SS} \downarrow$ to SCK \downarrow or SCK \uparrow input	Tcy	—	—	ns	
71 71A	TscH	SCK input high time (Slave mode)	Continuous Single Byte	1.25Tcy + 30 40	— —	ns	(Note 1)
72 72A	TscL	SCK input low time (Slave mode)	Continuous Single Byte	1.25Tcy + 30 40	— —	ns	(Note 1)
73	TdiV2scH, TdiV2scL	Setup time of SDI data input to SCK edge	100	—	—	ns	
73A	Tb2B	Last clock edge of Byte1 to the 1st clock edge of Byte2	1.5Tcy + 40	—	—	ns	(Note 1)
74	Tsch2diL, TscL2diL	Hold time of SDI data input to SCK edge	100	—	—	ns	
75	TdoR	SDO data output rise time	—	10	25	ns	
76	TdoF	SDO data output fall time	—	10	25	ns	
77	TssH2doZ	$\overline{SS} \uparrow$ to SDO output hi-impedance	10	—	50	ns	
78	TscR	SCK output rise time (Master mode)	—	10	25	ns	
79	TscF	SCK output fall time (Master mode)	—	10	25	ns	
80	Tsch2doV, TscL2doV	SDO data output valid after SCK edge	—	—	50	ns	
83	Tsch2ssH, TscL2ssH	$\overline{SS} \uparrow$ after SCK edge	1.5Tcy + 40	—	—	ns	

† Data in "Typ" column is at 5V, 25°C unless otherwise stated.

Note 1: Specification 73A is only required if specifications 71A and 72A are used.

FIGURE 20-16: SPI SLAVE MODE TIMING (CKE = 1)

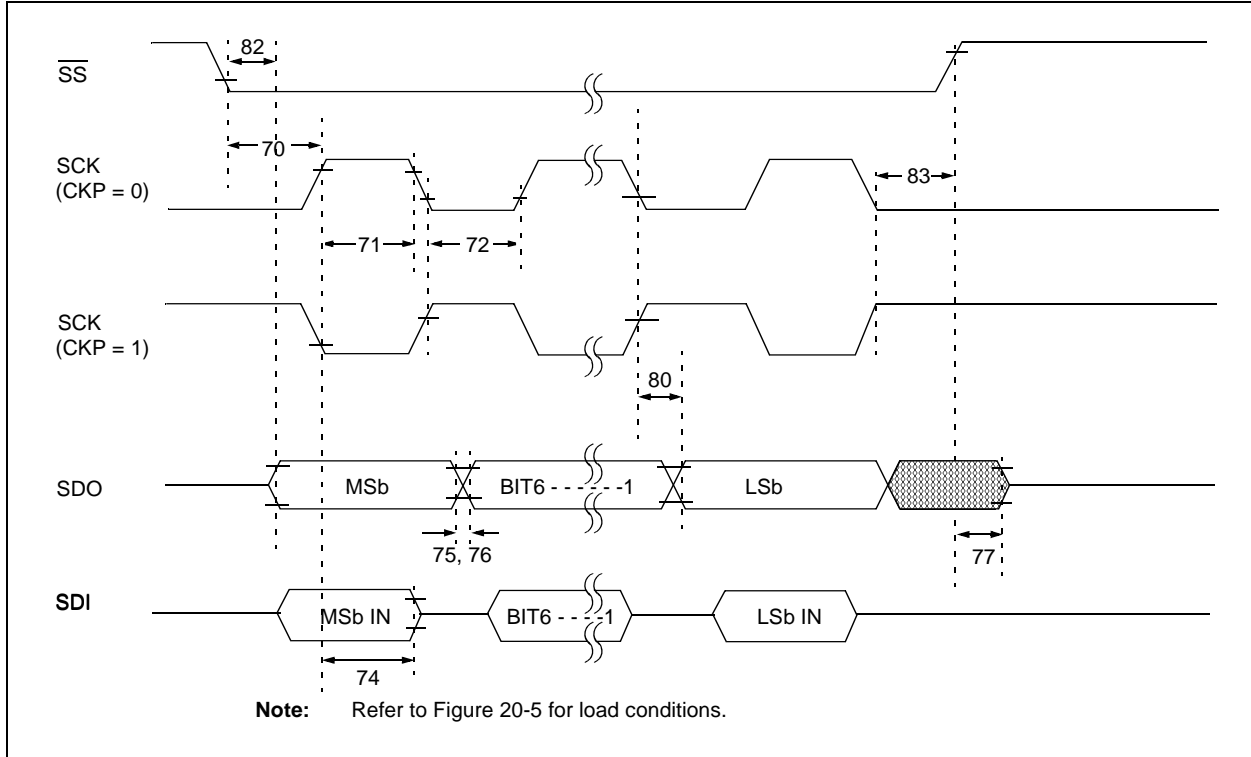

TABLE 20-11: SPI MODE REQUIREMENTS (SLAVE MODE, CKE = 1)

Param. No.	Symbol	Characteristic	Min	Typ†	Max	Units	Conditions
70	TssL2scH, TssL2scL	$\overline{SS}\downarrow$ to SCK \downarrow or SCK \uparrow input	Tcy	—	—	ns	
71	Tsch	SCK input high time (Slave mode)	Continuous	1.25Tcy + 30	—	—	ns
71A			Single Byte	40	—	—	ns
72	TscL	SCK input low time (Slave mode)	Continuous	1.25Tcy + 30	—	—	ns
72A			Single Byte	40	—	—	ns
73A	Tb2B	Last clock edge of Byte1 to the 1st clock edge of Byte2	1.5Tcy + 40	—	—	ns	(Note 1)
74	Tsch2diL, TscL2diL	Hold time of SDI data input to SCK edge	100	—	—	ns	
75	TdoR	SDO data output rise time	—	10	25	ns	
76	TdoF	SDO data output fall time	—	10	25	ns	
77	TssH2doZ	$\overline{SS}\uparrow$ to SDO output hi-impedance	10	—	50	ns	
80	Tsch2doV, TscL2doV	SDO data output valid after SCK edge	—	—	50	ns	
82	TssL2doV	SDO data output valid after $\overline{SS}\downarrow$ edge	—	—	50	ns	
83	Tsch2ssH, TscL2ssH	$\overline{SS}\uparrow$ after SCK edge	1.5Tcy + 40	—	—	ns	

† Data in "Typ" column is at 5V, 25°C unless otherwise stated.

Note 1: Specification 73A is only required if specifications 71A and 72A are used.

PIC17C7XX

FIGURE 20-17: I²C BUS START/STOP BITS TIMING

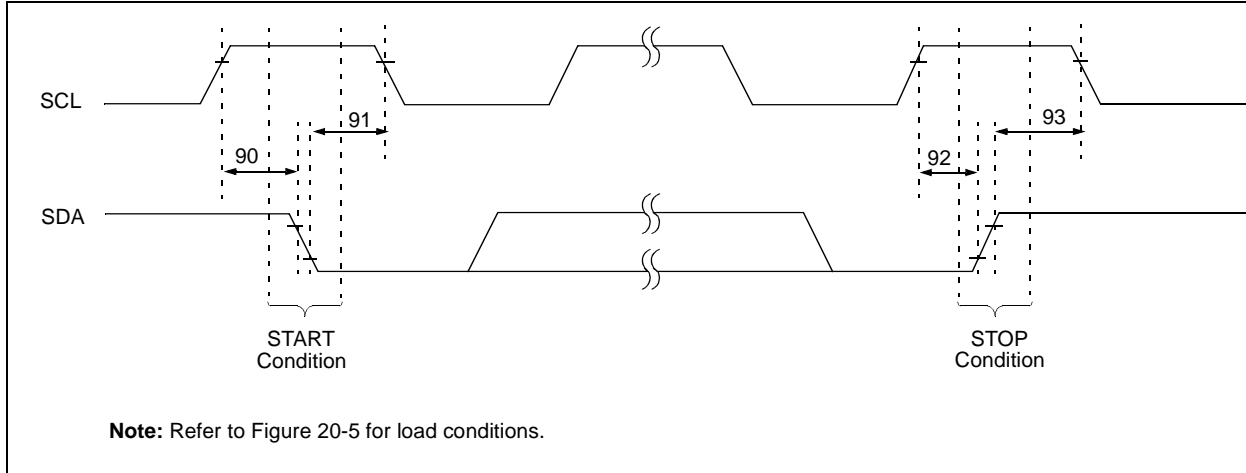

TABLE 20-12: I²C BUS START/STOP BITS REQUIREMENTS

Param. No.	Sym	Characteristic	Min	Typ	Max	Units	Conditions
90	Tsu:sta	START condition Setup time	100 kHz mode	—	—	ns	Only relevant for Repeated Start condition
			400 kHz mode	—	—		
			1 MHz mode ⁽¹⁾	—	—		
91	Thd:sta	START condition Hold time	100 kHz mode	—	—	ns	After this period, the first clock pulse is generated
			400 kHz mode	—	—		
			1 MHz mode ⁽¹⁾	—	—		
92	Tsu:sto	STOP condition Setup time	100 kHz mode	—	—	ns	
			400 kHz mode	—	—		
			1 MHz mode ⁽¹⁾	—	—		
93	Thd:sto	STOP condition Hold time	100 kHz mode	—	—	ns	
			400 kHz mode	—	—		
			1 MHz mode ⁽¹⁾	—	—		

Note 1: Maximum pin capacitance = 10 pF for all I²C pins.

FIGURE 20-18: I²C BUS DATA TIMING

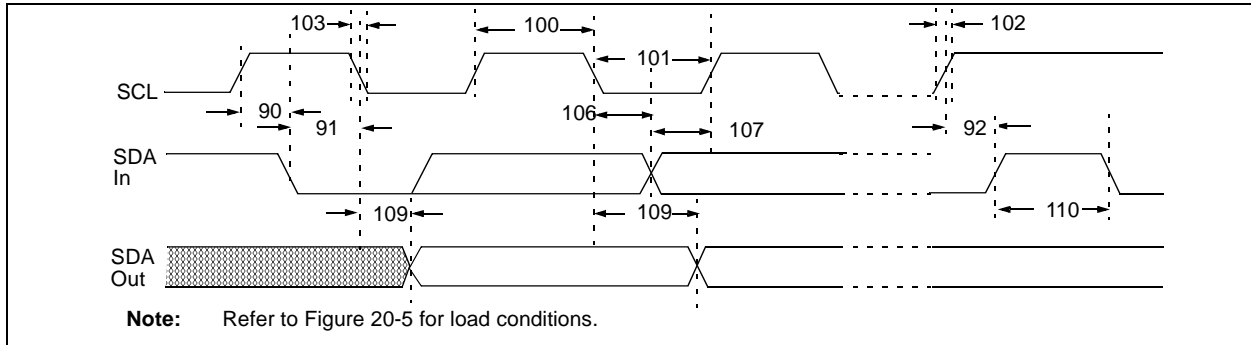

TABLE 20-13: I²C BUS DATA REQUIREMENTS

Param No.	Sym	Characteristic	Min	Max	Units	Conditions	
100	Thigh	Clock high time	100 kHz mode	$2(T_{osc})(BRG + 1)$	—	ms	
			400 kHz mode	$2(T_{osc})(BRG + 1)$	—	ms	
			1 MHz mode ⁽¹⁾	$2(T_{osc})(BRG + 1)$	—	ms	
101	Tlow	Clock low time	100 kHz mode	$2(T_{osc})(BRG + 1)$	—	ms	
			400 kHz mode	$2(T_{osc})(BRG + 1)$	—	ms	
			1 MHz mode ⁽¹⁾	$2(T_{osc})(BRG + 1)$	—	ms	
102	Tr	SDA and SCL rise time	100 kHz mode	—	1000	ns	Cb is specified to be from 10 to 400 pF
			400 kHz mode	$20 + 0.1C_b$	300	ns	
			1 MHz mode ⁽¹⁾	—	300	ns	
103	Tf	SDA and SCL fall time	100 kHz mode	—	300	ns	Cb is specified to be from 10 to 400 pF
			400 kHz mode	$20 + 0.1C_b$	300	ns	
			1 MHz mode ⁽¹⁾	—	10	ns	
90	Tsu:sta	START condition setup time	100 kHz mode	$2(T_{osc})(BRG + 1)$	—	ms	Only relevant for Repeated Start condition
			400 kHz mode	$2(T_{osc})(BRG + 1)$	—	ms	
			1 MHz mode ⁽¹⁾	$2(T_{osc})(BRG + 1)$	—	ms	
91	Thd:sta	START condition hold time	100 kHz mode	$2(T_{osc})(BRG + 1)$	—	ms	After this period, the first clock pulse is generated
			400 kHz mode	$2(T_{osc})(BRG + 1)$	—	ms	
			1 MHz mode ⁽¹⁾	$2(T_{osc})(BRG + 1)$	—	ms	
106	Thd:dat	Data input hold time	100 kHz mode	0	—	ns	
			400 kHz mode	0	0.9	ms	
			1 MHz mode ⁽¹⁾	0	—	ns	
107	Tsu:dat	Data input setup time	100 kHz mode	250	—	ns	(Note 2)
			400 kHz mode	100	—	ns	
			1 MHz mode ⁽¹⁾	100	—	ns	
92	Tsu:sto	STOP condition setup time	100 kHz mode	$2(T_{osc})(BRG + 1)$	—	ms	
			400 kHz mode	$2(T_{osc})(BRG + 1)$	—	ms	
			1 MHz mode ⁽¹⁾	$2(T_{osc})(BRG + 1)$	—	ms	
109	Taa	Output valid from clock	100 kHz mode	—	3500	ns	
			400 kHz mode	—	1000	ns	
			1 MHz mode ⁽¹⁾	—	400	ns	

- Note** 1: Maximum pin capacitance = 10 pF for all I²C pins.
- 2: A fast mode (400 KHz) I²C bus device can be used in a standard mode I²C bus system, but the parameter # 107 \geq 250 ns must then be met. This will automatically be the case if the device does not stretch the LOW period of the SCL signal. If such a device does stretch the LOW period of the SCL signal, it must output the next data bit to the SDA line. Parameter #102 + #107 = 1000 + 250 = 1250 ns (for 100 kHz mode) before the SCL line is released.
- 3: C_b is specified to be from 10-400pF. The minimum specifications are characterized with C_b=10pF. The rise time spec (t_r) is characterized with R_p=R_p min. The minimum fall time specification (t_f) is characterized with C_b=10pF, and R_p=R_p max. These are only valid for fast mode operation (V_{DD}=4.5-5.5V) and where the SPM bit (SSPSTAT<7>) =1.)
- 4: Max specifications for these parameters are valid for falling edge only. Specs are characterized with R_p=R_p min and C_b=400pF for standard mode, 200pF for fast mode, and 10pF for 1MHz mode.

PIC17C7XX

Param No.	Sym	Characteristic		Min	Max	Units	Conditions
110	Tbuf	Bus free time	100 kHz mode	4.7	—	ms	Time the bus must be free before a new transmission can start
			400 kHz mode	1.3	—	ms	
			1 MHz mode ⁽¹⁾	0.5	—	ms	
D102	Cb	Bus capacitive loading		—	400	pF	

- Note**
- 1: Maximum pin capacitance = 10 pF for all I²C pins.
 - 2: A fast mode (400 KHz) I²C bus device can be used in a standard mode I²C bus system, but the parameter # 107 ≥ 250 ns must then be met. This will automatically be the case if the device does not stretch the LOW period of the SCL signal. If such a device does stretch the LOW period of the SCL signal, it must output the next data bit to the SDA line. Parameter #102 + #107 = 1000 + 250 = 1250 ns (for 100 kHz mode) before the SCL line is released.
 - 3: C_b is specified to be from 10-400pF. The minimum specifications are characterized with C_b=10pF. The rise time spec (t_r) is characterized with R_p=R_p min. The minimum fall time specification (t_f) is characterized with C_b=10pF, and R_p=R_p max. These are only valid for fast mode operation (V_{DD}=4.5-5.5V) and where the SPM bit (SSPSTAT<7>) =1.)
 - 4: Max specifications for these parameters are valid for falling edge only. Specs are characterized with R_p=R_p min and C_b=400pF for standard mode, 200pF for fast mode, and 10pF for 1MHz mode.

FIGURE 20-19: USART SYNCHRONOUS TRANSMISSION (MASTER/SLAVE) TIMING

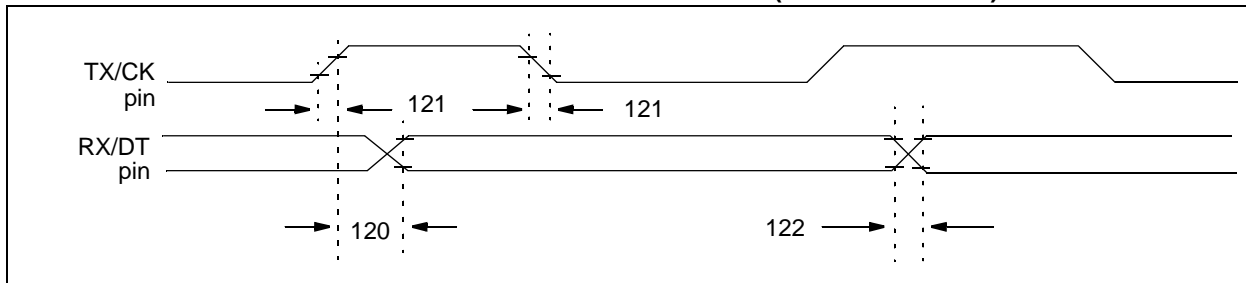

TABLE 20-14: USART SYNCHRONOUS TRANSMISSION REQUIREMENTS

Param No.	Sym	Characteristic		Min	Typ†	Max	Units	Conditions	
120	TckH2dtV	<u>SYNC XMIT (MASTER & SLAVE)</u>							
		Clock high to data out valid		PIC17CXXX	—	—	50	ns	
121	TckRF	Clock out rise time and fall time (Master mode)		PIC17CXXX	—	—	25	ns	
				PIC17LCXXX	—	—	40	ns	
122	TdtRF	Data out rise time and fall time		PIC17CXXX	—	—	25	ns	
				PIC17LCXXX	—	—	40	ns	

† Data in "Typ" column is at 5V, 25°C unless otherwise stated.

FIGURE 20-20: USART SYNCHRONOUS RECEIVE (MASTER/SLAVE) TIMING

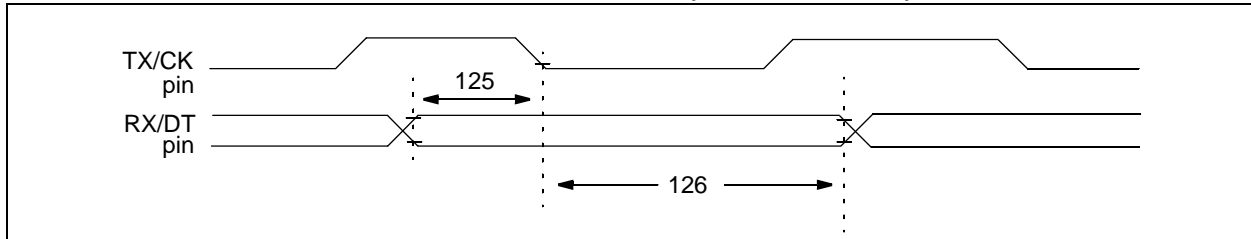

TABLE 20-15: USART SYNCHRONOUS RECEIVE REQUIREMENTS

Param No.	Sym	Characteristic	Min	Typ†	Max	Units	Conditions
125	TdtV2ckL	SYNC RCV (MASTER & SLAVE) Data setup before CK↓ (DT setup time)	15	—	—	ns	
126	TckL2dtl	Data hold after CK↓ (DT hold time)	15	—	—	ns	

† Data in "Typ" column is at 5V, 25°C unless otherwise stated.

PIC17C7XX

FIGURE 20-21: USART ASYNCHRONOUS MODE START BIT DETECT

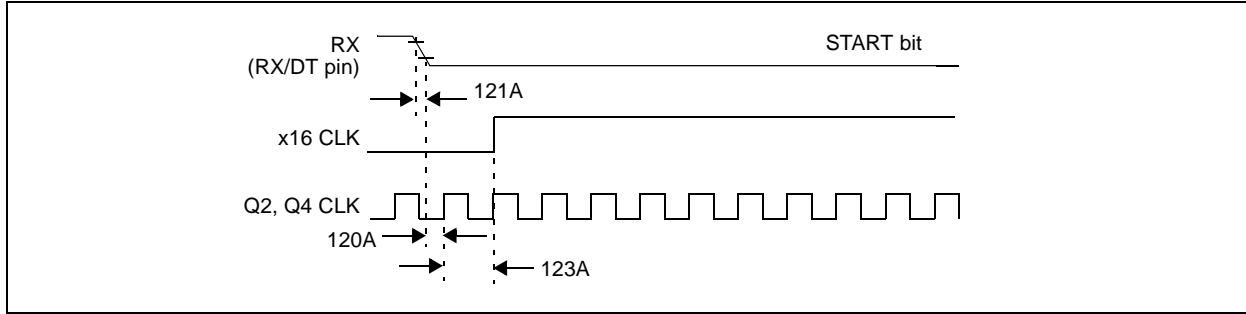

TABLE 20-16: USART ASYNCHRONOUS MODE START BIT DETECT REQUIREMENTS

Param No.	Sym	Characteristic	Min	Typ	Max	Units	Conditions
120A	TdtL2ckH	Time to ensure that the RX pin is sampled low	—	—	T _{CY}	ns	
121A	TdtRF	Receive	—	—	(Note 1)	ns	
		Transmit	—	—	40	ns	
123A	TckH2bckL	Time from RX pin sampled low to first rising edge of x16 clock	—	—	T _{CY}	ns	

Note 1: Schmitt trigger will determine logic level.

FIGURE 20-22: USART ASYNCHRONOUS RECEIVE SAMPLING WAVEFORM

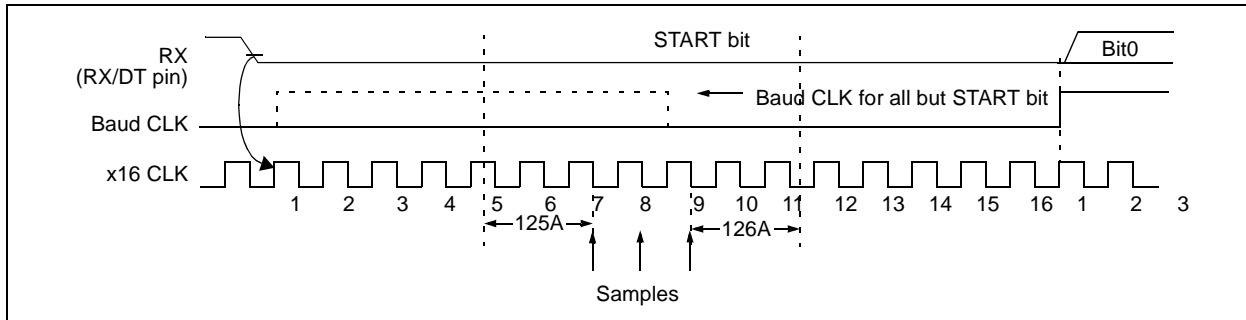

TABLE 20-17: USART ASYNCHRONOUS RECEIVE SAMPLING REQUIREMENTS

Param No.	Sym	Characteristic	Min	Typ	Max	Units	Conditions
125A	TdtL2ckH	Setup time of RX pin to first data sampled	T _{CY}	—	—	ns	
126A	TdtL2ckH	Hold time of RX pin from last data sampled	T _{CY}	—	—	ns	

TABLE 20-18: A/D CONVERTER CHARACTERISTICS

Param. No.	Sym	Characteristic	Min	Typ†	Max	Units	Conditions
A01	NR	Resolution	—	—	10	bit	$V_{REF+} = V_{DD} = 5.12V$, $V_{SS} \leq V_{AIN} \leq V_{REF+}$
			—	—	10	bit	$(V_{REF+} - V_{REF-}) \geq 3.0V$, $V_{REF-} \leq V_{AIN} \leq V_{REF+}$
A02	EABS	Absolute error	—	—	$< \pm 1$	LSb	$V_{REF+} = V_{DD} = 5.12V$, $V_{SS} \leq V_{AIN} \leq V_{REF+}$
			—	—	$< \pm 1$	LSb	$(V_{REF+} - V_{REF-}) \geq 3.0V$, $V_{REF-} \leq V_{AIN} \leq V_{REF+}$
A03	EIL	Integral linearity error	—	—	$< \pm 1$	LSb	$V_{REF+} = V_{DD} = 5.12V$, $V_{SS} \leq V_{AIN} \leq V_{REF+}$
			—	—	$< \pm 1$	LSb	$(V_{REF+} - V_{REF-}) \geq 3.0V$, $V_{REF-} \leq V_{AIN} \leq V_{REF+}$
A04	EDL	Differential linearity error	—	—	$< \pm 1$	LSb	$V_{REF+} = V_{DD} = 5.12V$, $V_{SS} \leq V_{AIN} \leq V_{REF+}$
			—	—	$< \pm 1$	LSb	$(V_{REF+} - V_{REF-}) \geq 3.0V$, $V_{REF-} \leq V_{AIN} \leq V_{REF+}$
A05	EFS	Full scale error	—	—	$< \pm 1$	LSb	$V_{REF+} = V_{DD} = 5.12V$, $V_{SS} \leq V_{AIN} \leq V_{REF+}$
			—	—	$< \pm 1$	LSb	$(V_{REF+} - V_{REF-}) \geq 3.0V$, $V_{REF-} \leq V_{AIN} \leq V_{REF+}$
A06	EOFF	Offset error	—	—	$< \pm 1$	LSb	$V_{REF+} = V_{DD} = 5.12V$, $V_{SS} \leq V_{AIN} \leq V_{REF+}$
			—	—	$< \pm 1$	LSb	$(V_{REF+} - V_{REF-}) \geq 3.0V$, $V_{REF-} \leq V_{AIN} \leq V_{REF+}$
A10	—	Monotonicity	—	guaranteed ⁽³⁾	—	—	$V_{SS} \leq V_{AIN} \leq V_{REF}$
A20	VREF	Reference voltage ($V_{REF+} - V_{REF-}$)	0V	—	—	V	VREF delta when changing voltage levels on VREF inputs
A20A			3V	—	—	V	Absolute minimum electrical spec. to ensure 10-bit accuracy
A21	VREF+	Reference voltage high	$AV_{SS} + 3.0V$	—	$AV_{DD} + 0.3V$	V	
A22	VREF-	Reference voltage low	$AV_{SS} - 0.3V$	—	$AV_{DD} - 3.0V$	V	
A25	VAIN	Analog input voltage	$AV_{SS} - 0.3V$	—	$V_{ref} + 0.3V$	V	
A30	ZAIN	Recommended impedance of analog voltage source	—	—	10.0	k Ω	
A40	IAD	A/D conversion current (V_{DD})	PIC17CXXX	180	—	μA	Average current consumption when A/D is on (Note 1)
			PIC17LCXXX	90	—	μA	
A50	IREF	VREF input current (Note 2)	10	—	1000	μA	During VAIN acquisition. Based on differential of V_{HOLD} to VAIN
			—	—	10	μA	During A/D conversion cycle

† Data in "Typ" column is at 5V, 25°C unless otherwise stated.

Note 1: When A/D is off, it will not consume any current other than minor leakage current. The power-down current spec includes any such leakage from the A/D module.

2: VREF current is from RG0 and RG1 pins or AVDD and AVSS pins, whichever is selected as reference input.

3: The A/D conversion result never decreases with an increase in the Input Voltage and has no missing codes.

PIC17C7XX

FIGURE 20-23: A/D CONVERSION TIMING

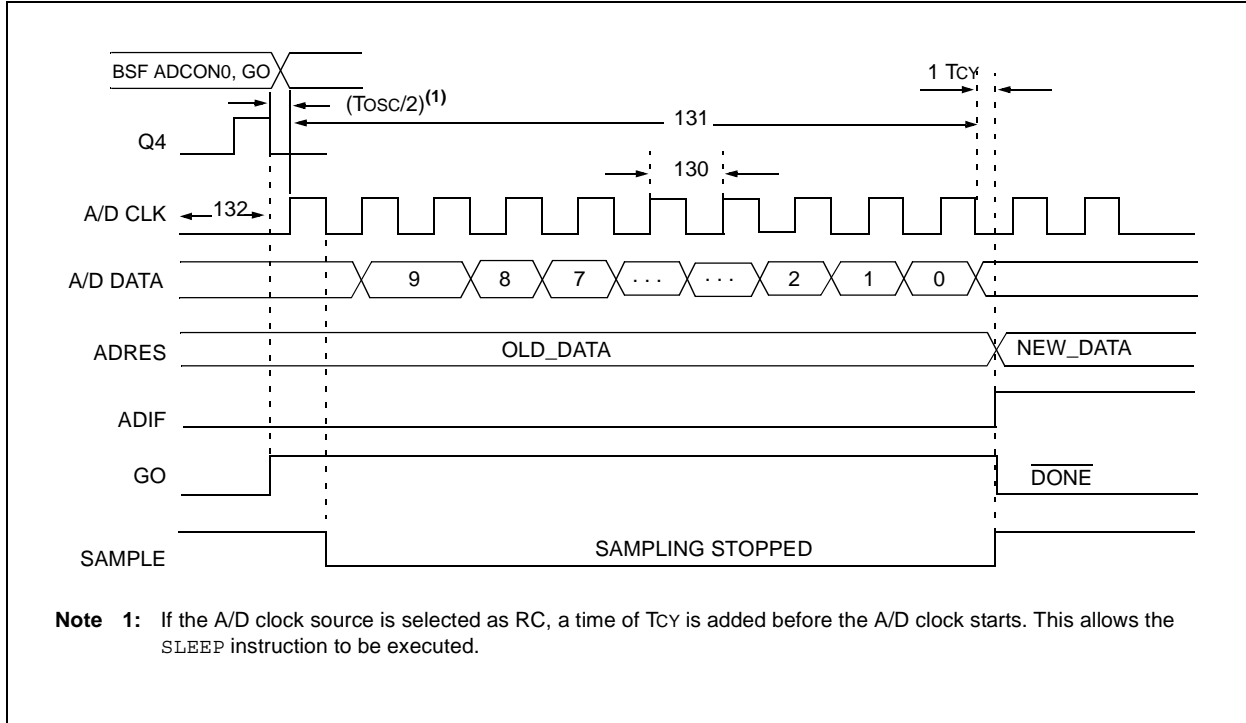

TABLE 20-19: A/D CONVERSION REQUIREMENTS

Param. No.	Sym	Characteristic	Min	Typ†	Max	Units	Conditions	
130	TAD	A/D clock period	PIC17CXXX	1.6	—	—	μs	TOSC based, $V_{REF} \geq 3.0\text{V}$
			PIC17LCXXX	3.0	—	—	μs	TOSC based, V_{REF} full range
			PIC17CXXX	2.0	4.0	6.0	μs	A/D RC mode
			PIC17LCXXX	3.0	6.0	9.0	μs	A/D RC mode
131	TCNV	Conversion time (not including acquisition time) (Note 1)	11	—	12	Tad		
132	TACQ	Acquisition time	(Note 2)	20	—	μs	The minimum time is the amplifier settling time. This may be used if the "new" input voltage has not changed by more than 1LSb (i.e., 5 mV @ 5.12V) from the last sampled voltage (as stated on CHOLD).	
			10	—	—	μs		
134	TGO	Q4 to ADCLK start	—	$T_{osc}/2$	—	—	If the A/D clock source is selected as RC, a time of T_{CY} is added before the A/D clock starts. This allows the SLEEP instruction to be executed.	

† Data in "Typ" column is at 5V, 25°C unless otherwise stated.

Note 1: ADRES register may be read on the following T_{CY} cycle.

Note 2: See Section 16.1 for minimum conditions when input voltage has changed more than 1 LSb.

FIGURE 20-24: MEMORY INTERFACE WRITE TIMING

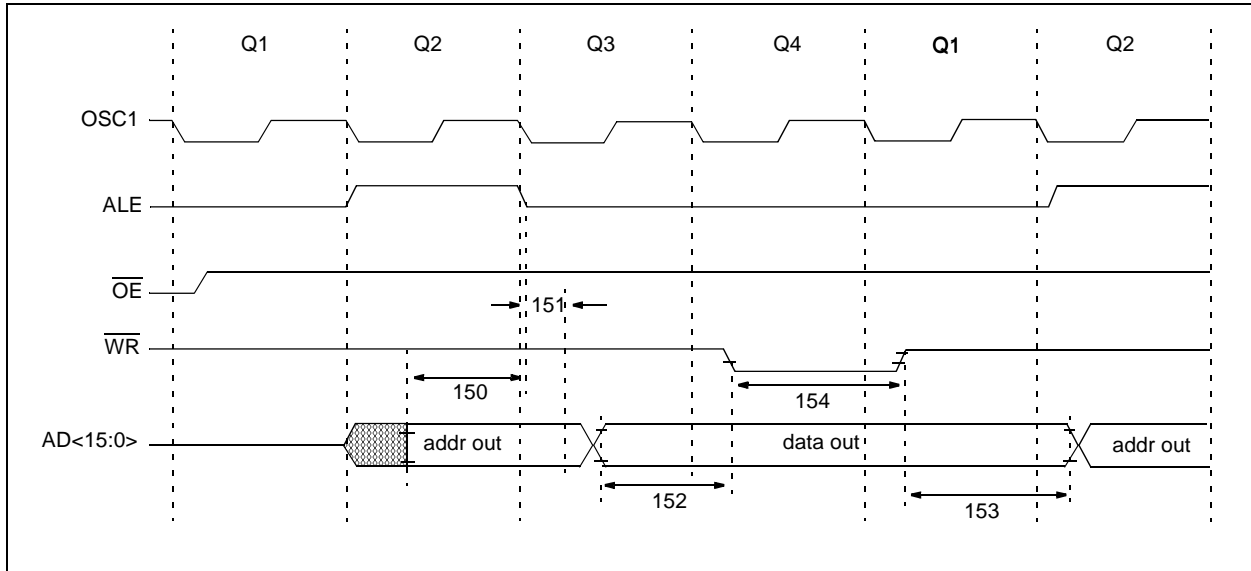

TABLE 20-20: MEMORY INTERFACE WRITE REQUIREMENTS

Param. No.	Sym	Characteristic		Min	Typ†	Max	Unit	Conditions
150	TadV2aL	AD<15:0> (address) valid to ALE↓ (address setup time)	PIC17CXXX	0.25Tcy - 10	—	—	ns	
			PIC17LCXXX	0.25Tcy - 10	—	—		
151	Tall2adI	ALE↓ to address out invalid (address hold time)	PIC17CXXX	0	—	—	ns	
			PIC17LCXXX	0	—	—		
152	TadV2wrL	Data out valid to WR↓ (data setup time)	PIC17CXXX	0.25Tcy - 40	—	—	ns	
			PIC17LCXXX	0.25Tcy - 40	—	—		
153	TwrH2adI	WR↑ to data out invalid (data hold time)	PIC17CXXX	—	0.25Tcy	—	ns	
			PIC17LCXXX	—	0.25Tcy	—		
154	TwrL	WR pulse width	PIC17CXXX	—	0.25Tcy	—	ns	
			PIC17LCXXX	—	0.25Tcy	—		

† Data in "Typ" column is at 5V, 25°C unless otherwise stated.

PIC17C7XX

FIGURE 20-25: MEMORY INTERFACE READ TIMING

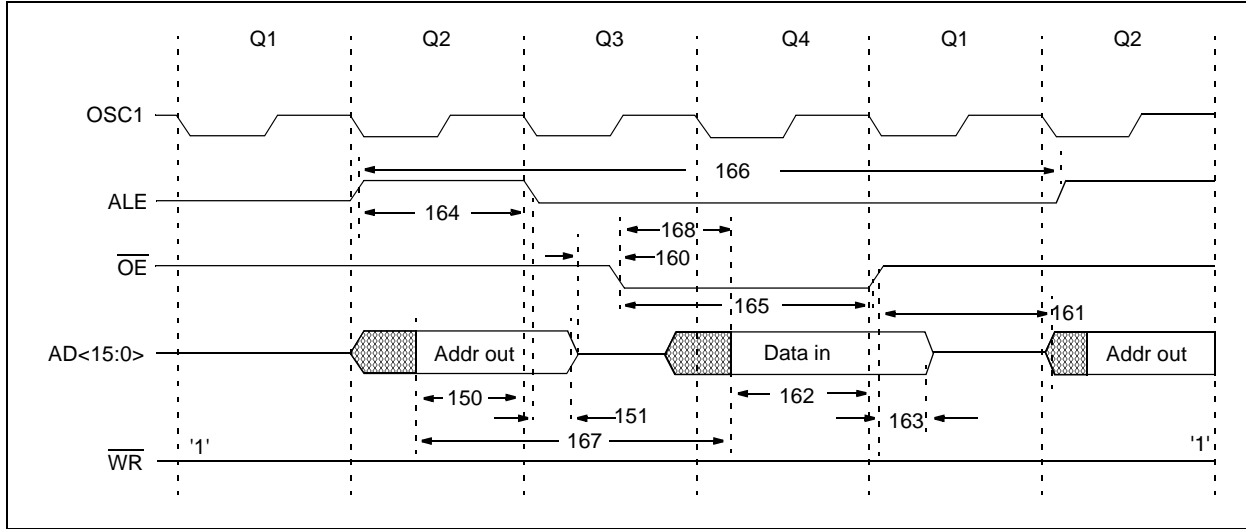

TABLE 20-21: MEMORY INTERFACE READ REQUIREMENTS

Param. No.	Sym	Characteristic	Min	Typ†	Max	Units	Conditions
150	TadV2alL	AD15:AD0 (address) valid to ALE↓ (address setup time)	PIC17CXXX	0.25Tcy - 10	—	—	ns
			PIC17LCXXX	0.25Tcy - 10	—	—	
151	TalL2adl	ALE↓ to address out invalid (address hold time)	PIC17CXXX	5	—	—	ns
			PIC17LCXXX	5	—	—	
160	TadZ2oeL	AD15:AD0 hi-impedance to OE↓	PIC17CXXX	0	—	—	ns
			PIC17LCXXX	0	—	—	
161	ToeH2adD	OE↑ to AD15:AD0 driven	PIC17CXXX	0.25Tcy - 15	—	—	ns
			PIC17LCXXX	0.25Tcy - 15	—	—	
162	TadV2oeH	Data in valid before OE↑ (data setup time)	PIC17CXXX	35	—	—	ns
			PIC17LCXXX	45	—	—	
163	ToeH2adl	OE↑ to data in invalid (data hold time)	PIC17CXXX	0	—	—	ns
			PIC17LCXXX	0	—	—	
164	TalH	ALE pulse width	PIC17CXXX	—	0.25Tcy	—	ns
			PIC17LCXXX	—	0.25Tcy	—	
165	ToeL	OE pulse width	PIC17CXXX	0.5Tcy - 35	—	—	ns
			PIC17LCXXX	0.5Tcy - 35	—	—	
166	TalH2alH	ALE↑ to ALE↑ (cycle time)	PIC17CXXX	—	Tcy	—	ns
			PIC17LCXXX	—	Tcy	—	
167	Tacc	Address access time	PIC17CXXX	—	—	0.75Tcy - 30	ns
			PIC17LCXXX	—	—	0.75Tcy - 45	
168	Toe	Output enable access time (OE low to data valid)	PIC17CXXX	—	—	0.5Tcy - 45	ns
			PIC17LCXXX	—	—	0.5Tcy - 75	

† Data in "Typ" column is at 5V, 25 °C unless otherwise stated.

21.0 PIC17C7XX DC AND AC CHARACTERISTICS

The graphs and tables provided in this section are for design guidance and are not tested nor guaranteed. In some graphs or tables the data presented is outside specified operating range (e.g., outside specified VDD range). This is for information only and devices are ensured to operate properly only within the specified range.

The data presented in this section is a statistical summary of data collected on units from different lots over a period of time.

- **Typ** or **Typical** represents the mean of the distribution at 25°C.
- **Max** or **Maximum** represents (mean + 3σ) over the temperature range of -40°C to 85°C.
- **Min** or **Minimum** represents (mean - 3σ) over the temperature range of -40°C to 85°C.

Note: Standard deviation is denoted by sigma (σ).

TABLE 21-1: PIN CAPACITANCE PER PACKAGE TYPE

Pin Name	Typical Capacitance (pF)	
	68-pin PLCC	64-pin TQFP
All pins, except $\overline{\text{MCLR}}$, VDD, and VSS	10	10
$\overline{\text{MCLR}}$ pin	20	20

FIGURE 21-1: TYPICAL RC OSCILLATOR FREQUENCY vs. TEMPERATURE

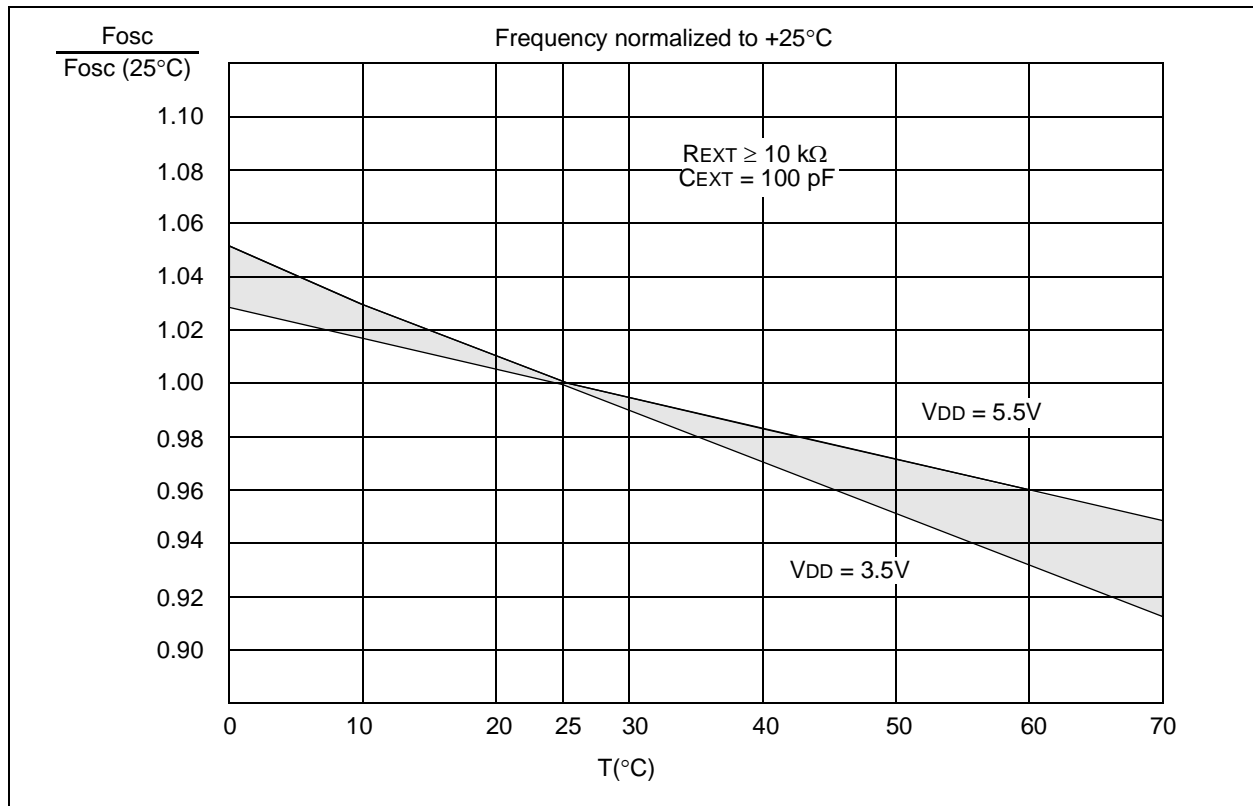

PIC17C7XX

FIGURE 21-2: TYPICAL RC OSCILLATOR FREQUENCY vs. VDD

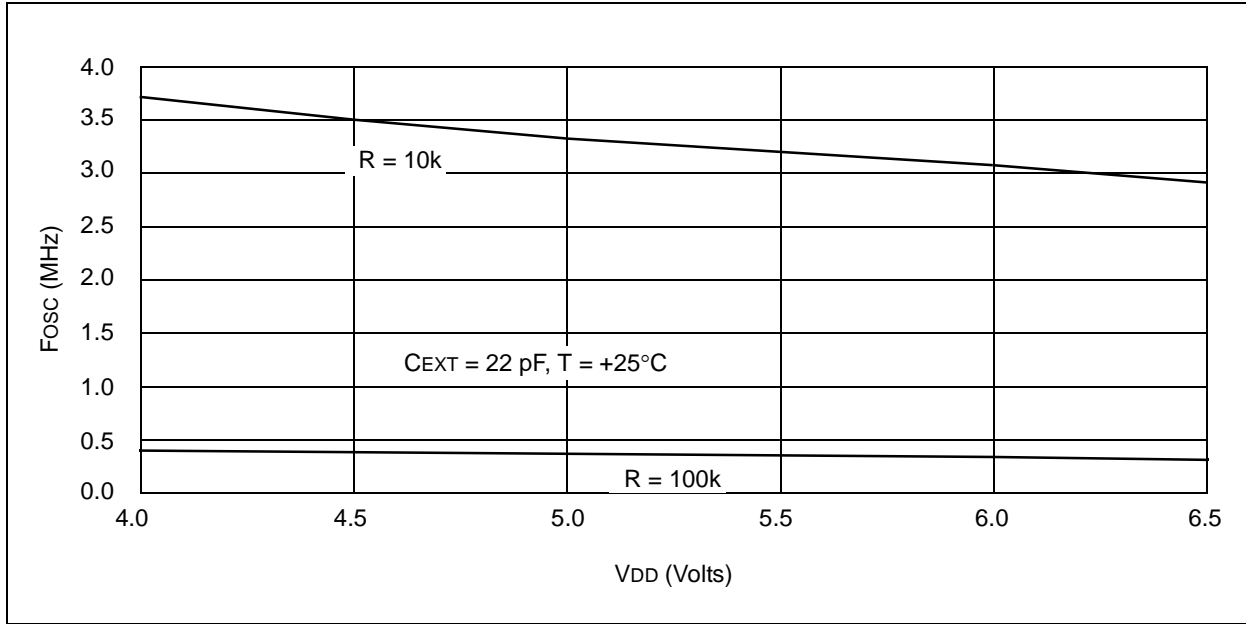

FIGURE 21-3: TYPICAL RC OSCILLATOR FREQUENCY vs. VDD

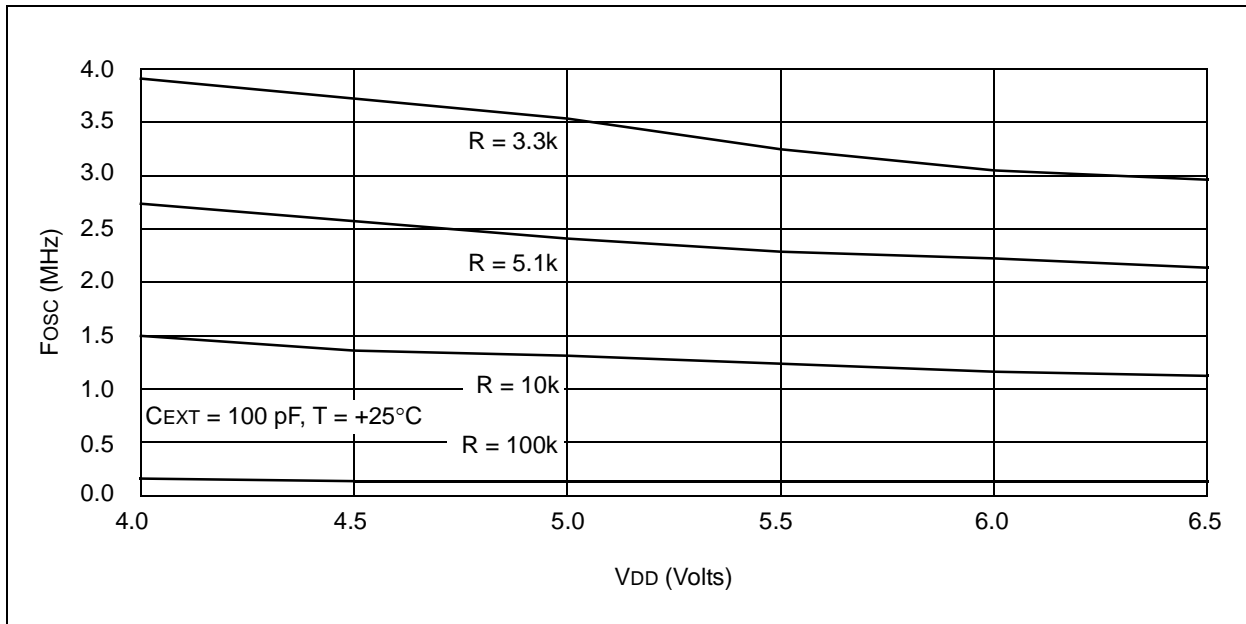

FIGURE 21-4: TYPICAL RC OSCILLATOR FREQUENCY vs. VDD

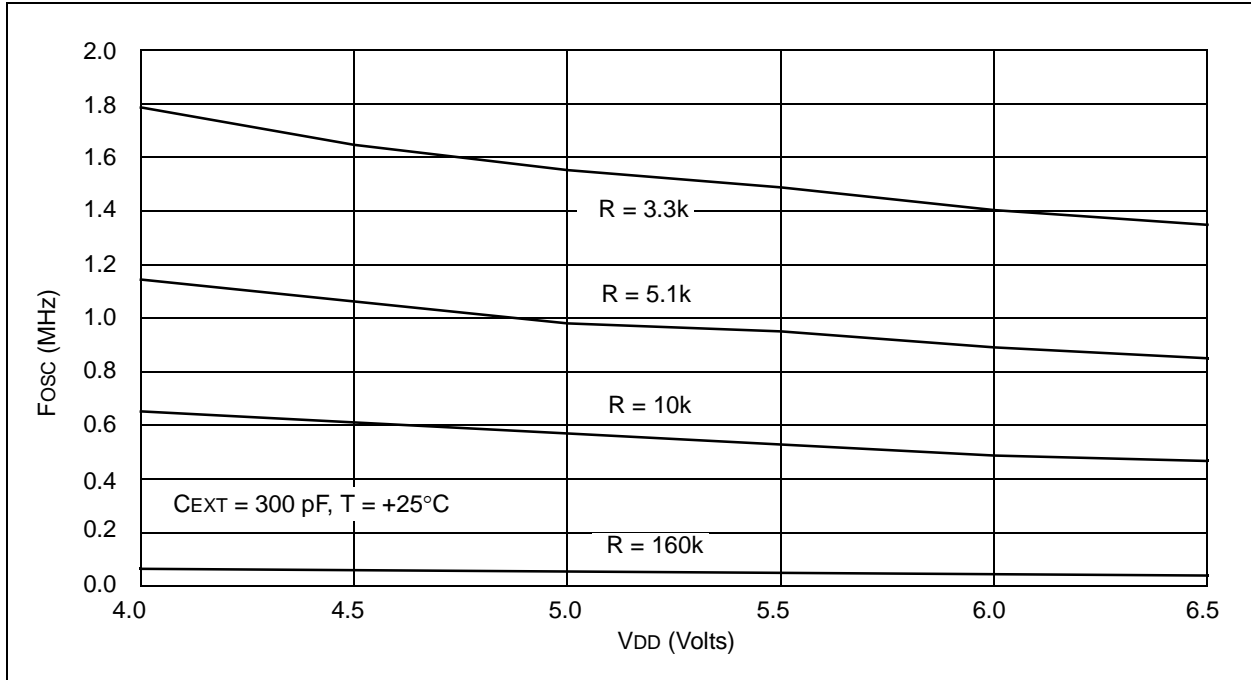

TABLE 21-2: RC OSCILLATOR FREQUENCIES

C _{EXT}	R _{EXT}	Average Fosc @ 5V, +25°C	
		Frequency	Tolerance
22 pF	10k	3.33 MHz	± 12%
	100k	353 kHz	± 13%
100 pF	3.3k	3.54 MHz	± 10%
	5.1k	2.43 MHz	± 14%
	10k	1.30 MHz	± 17%
	100k	129 kHz	± 10%
300 pF	3.3k	1.54 MHz	± 14%
	5.1k	980 kHz	± 12%
	10k	564 kHz	± 16%
	160k	35 kHz	± 18%

PIC17C7XX

FIGURE 21-5: TRANSCONDUCTANCE (gm) OF LF OSCILLATOR vs. VDD

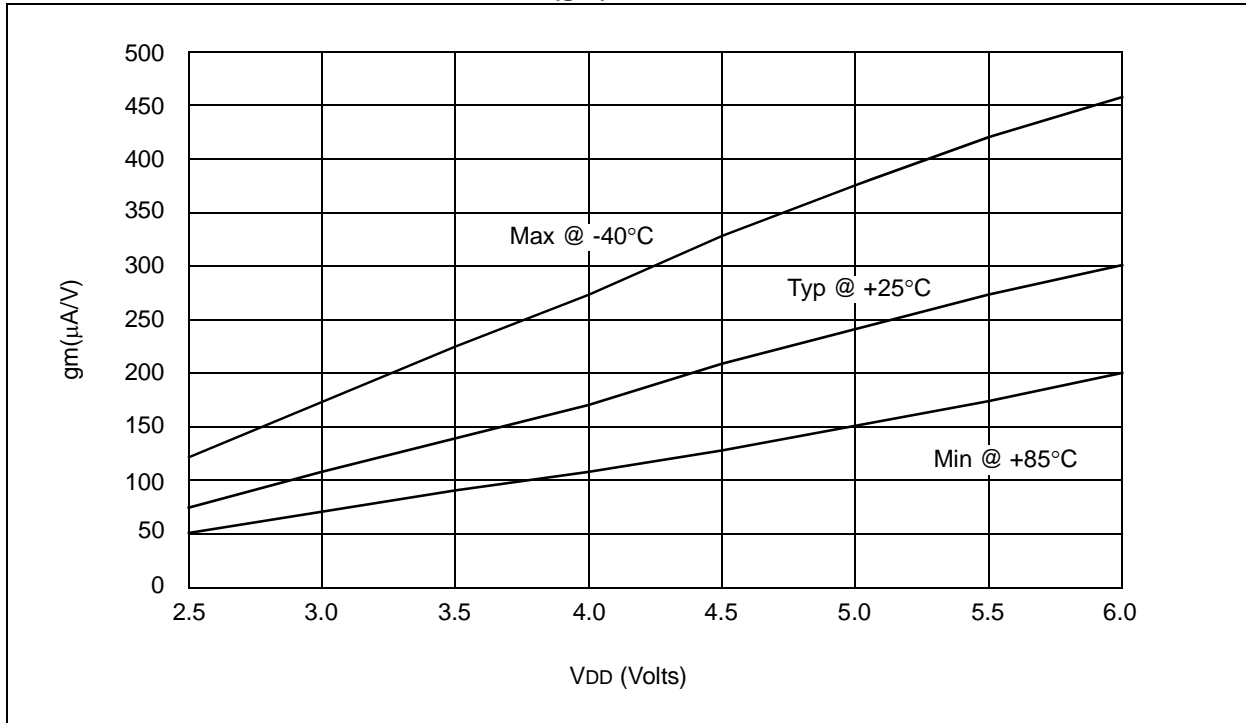

FIGURE 21-6: TRANSCONDUCTANCE (gm) OF XT OSCILLATOR vs. VDD

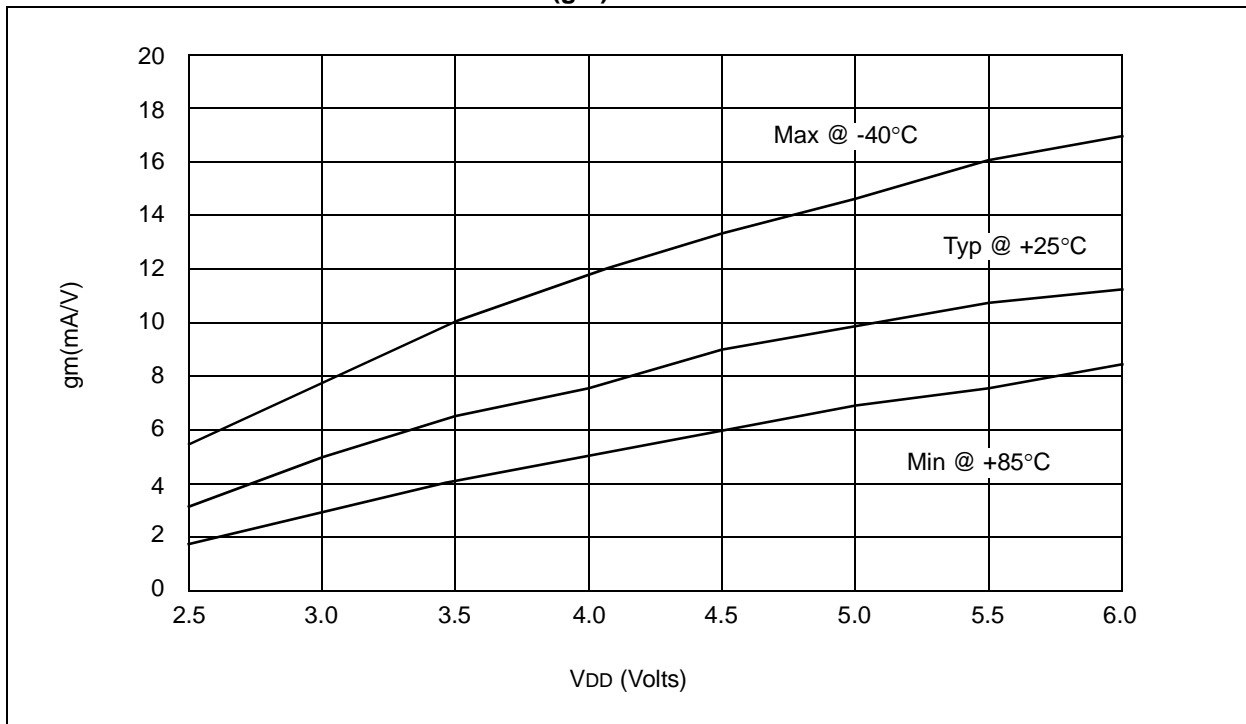

FIGURE 21-7: TYPICAL I_{DD} vs. F_{osc} OVER V_{DD} (LF MODE)

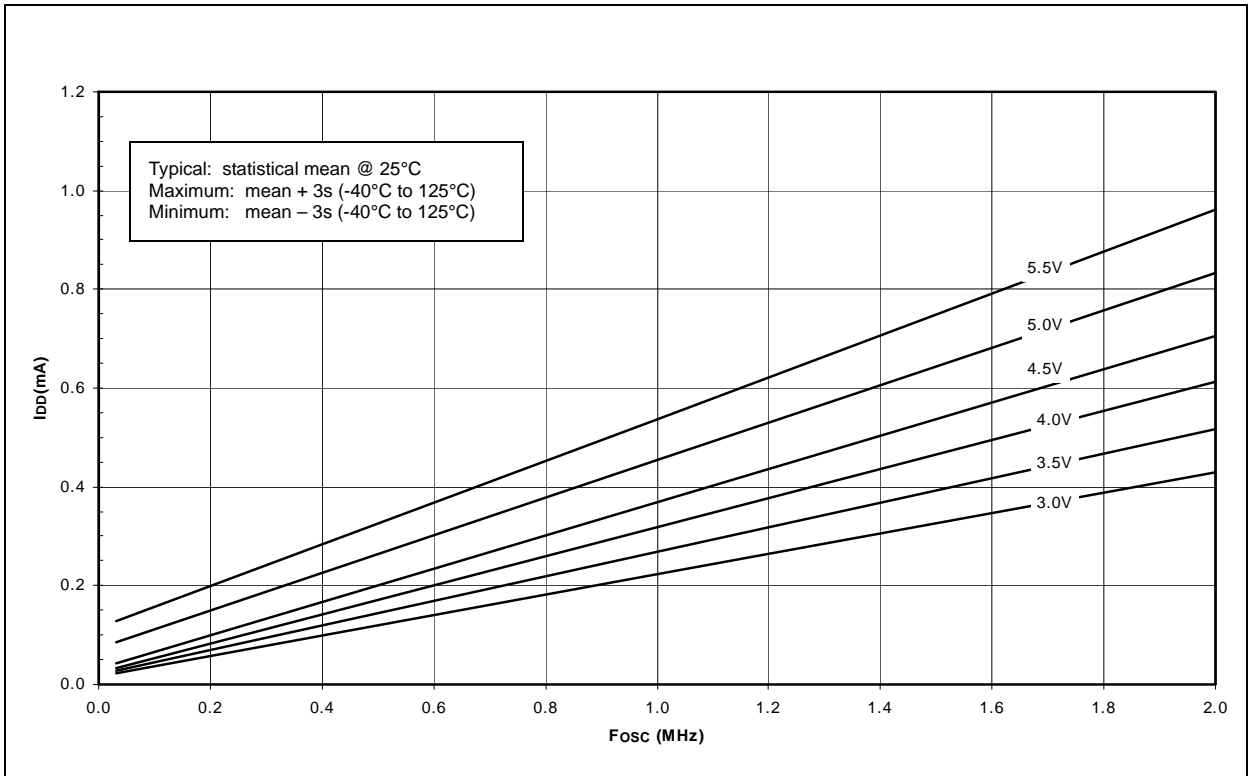
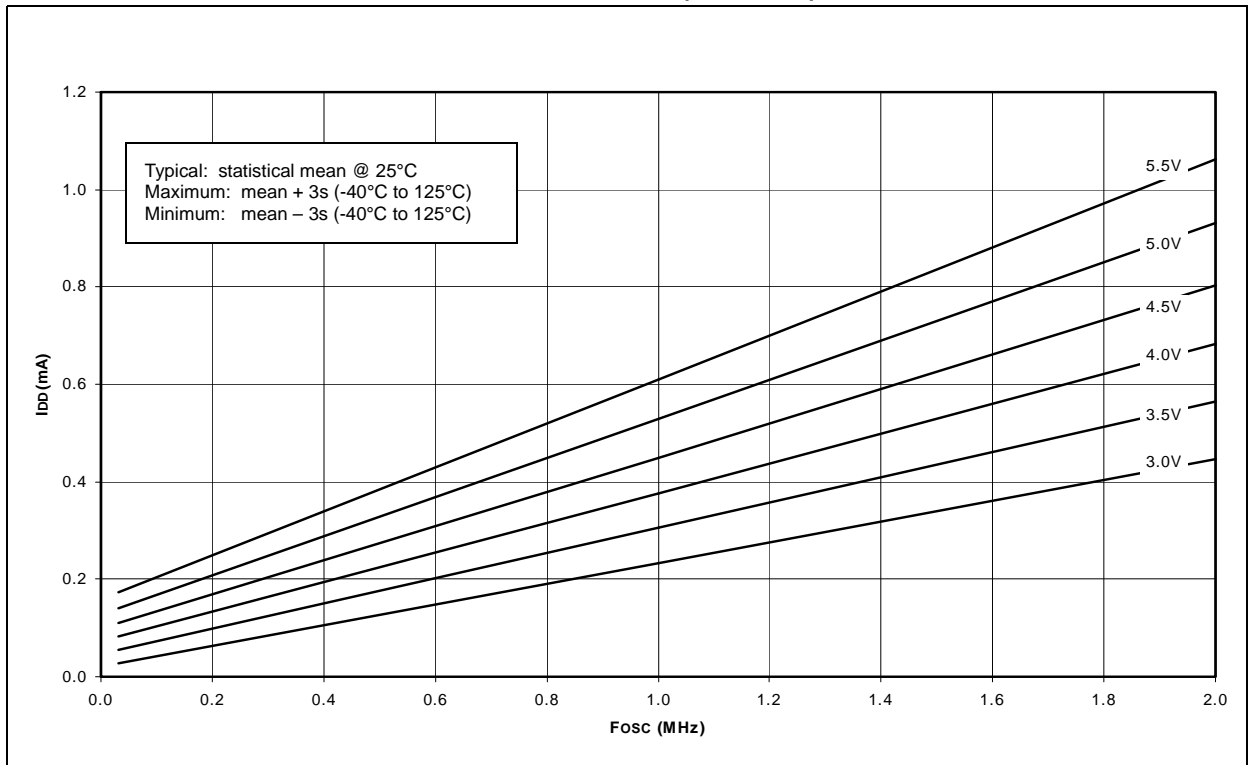

FIGURE 21-8: MAXIMUM I_{DD} vs. F_{osc} OVER V_{DD} (LF MODE)



PIC17C7XX

FIGURE 21-9: TYPICAL I_{DD} vs. F_{OSC} OVER V_{DD} (XT MODE)

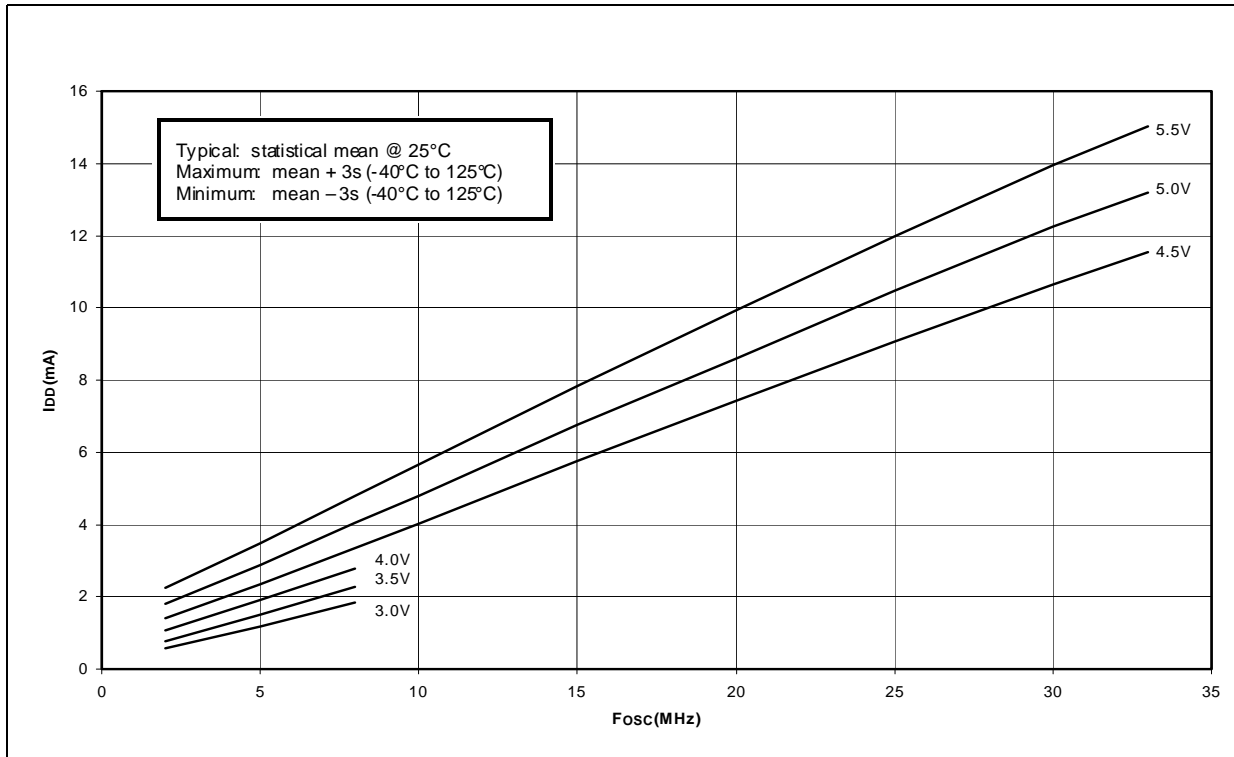

FIGURE 21-10: MAXIMUM I_{DD} vs. F_{OSC} OVER V_{DD} (XT MODE)

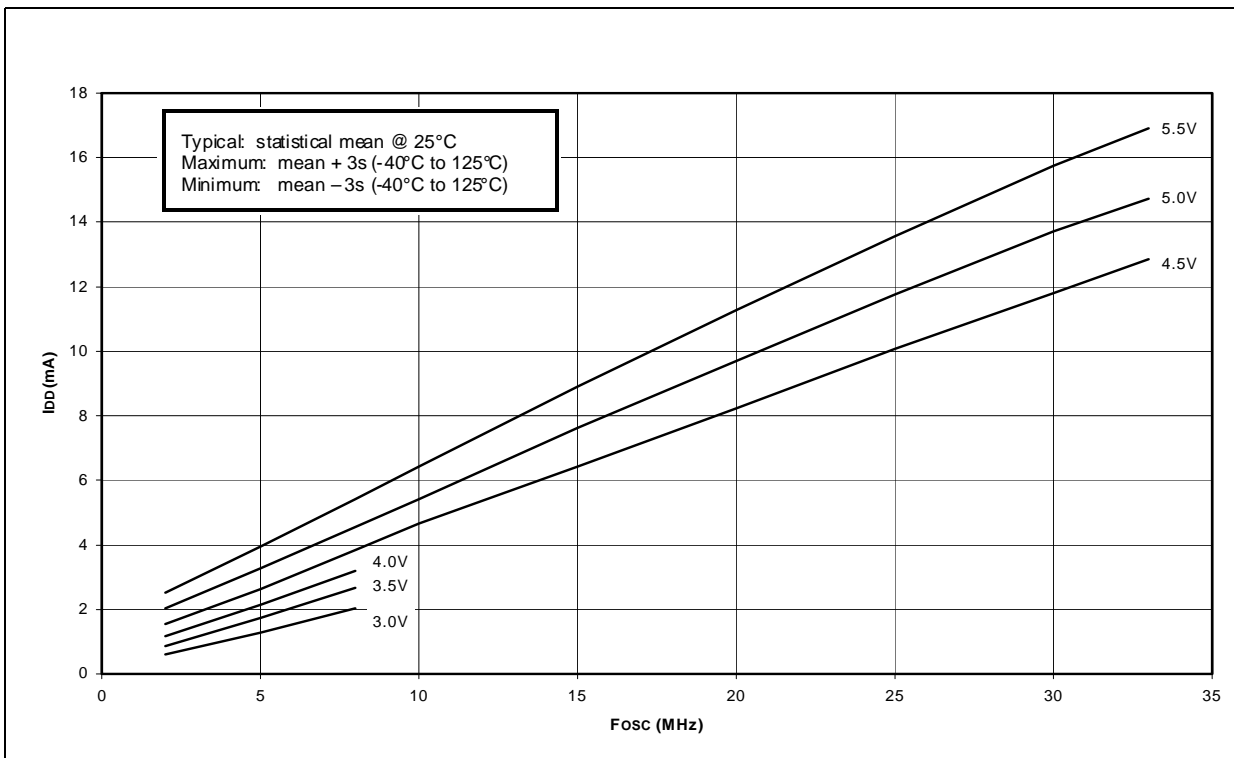

FIGURE 21-11: TYPICAL AND MAXIMUM I_{PD} vs. V_{DD} (SLEEP MODE, ALL PERIPHERALS DISABLED, -40°C to $+125^{\circ}\text{C}$)

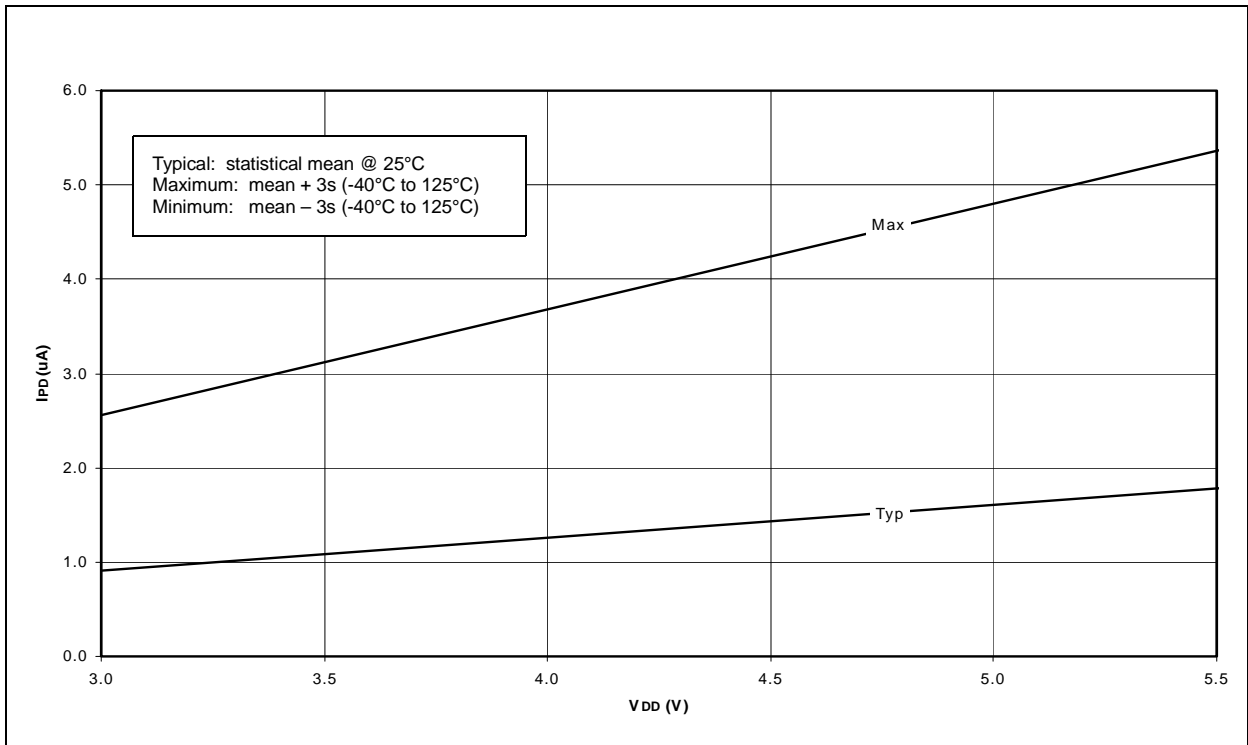
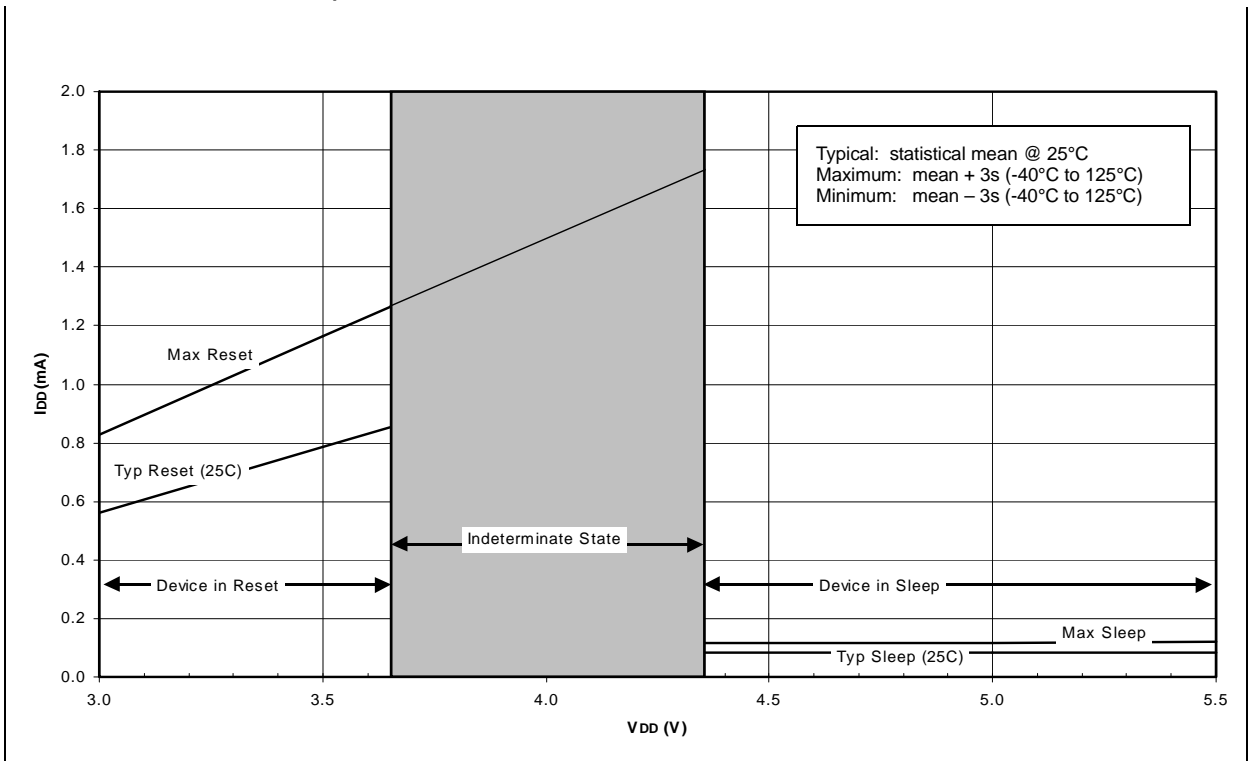

FIGURE 21-12: TYPICAL AND MAXIMUM I_{DD} vs. V_{DD} (SLEEP MODE, BOR ENABLED, -40°C to $+125^{\circ}\text{C}$)



PIC17C7XX

FIGURE 21-13: TYPICAL AND MAXIMUM ΔI_{PD} vs. V_{DD} (SLEEP MODE, WDT ENABLED, -40°C to $+125^{\circ}\text{C}$)

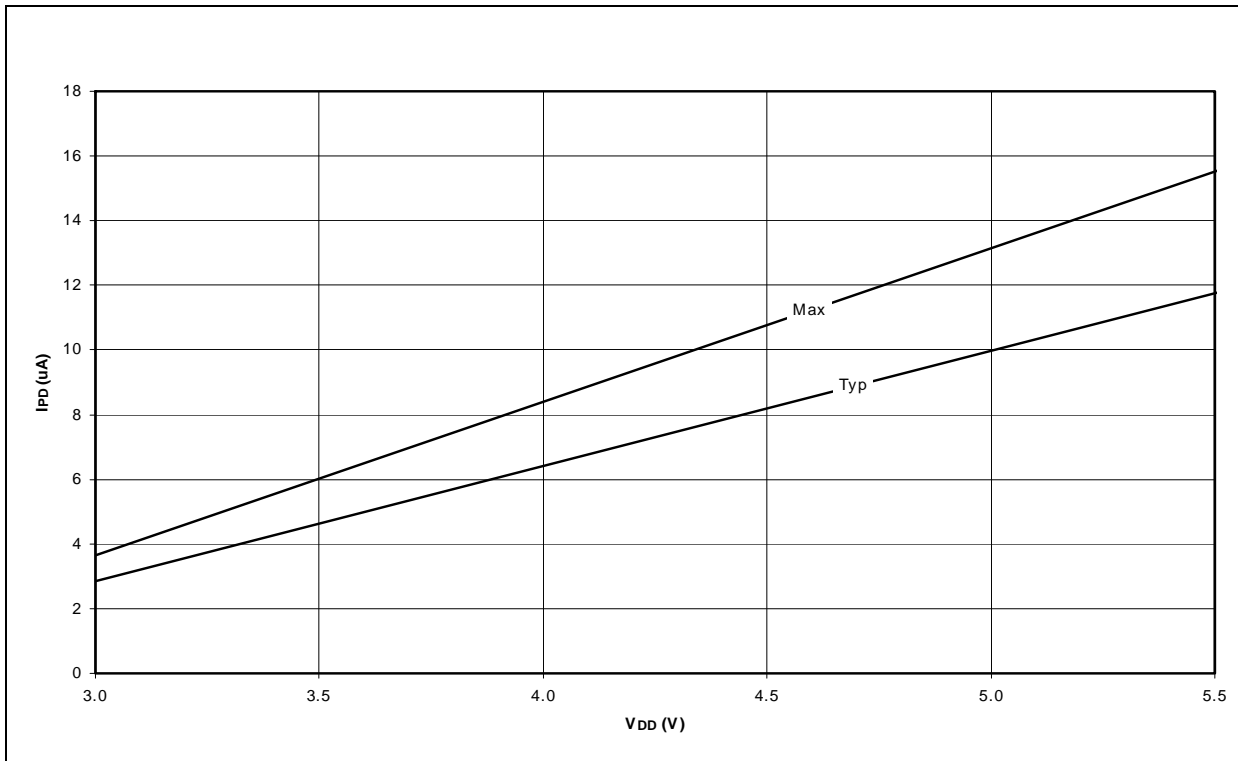

FIGURE 21-14: TYPICAL AND MAXIMUM ΔI_{RBPV} vs. V_{DD} (MEASURED PER INPUT PIN, -40°C TO $+125^{\circ}\text{C}$)

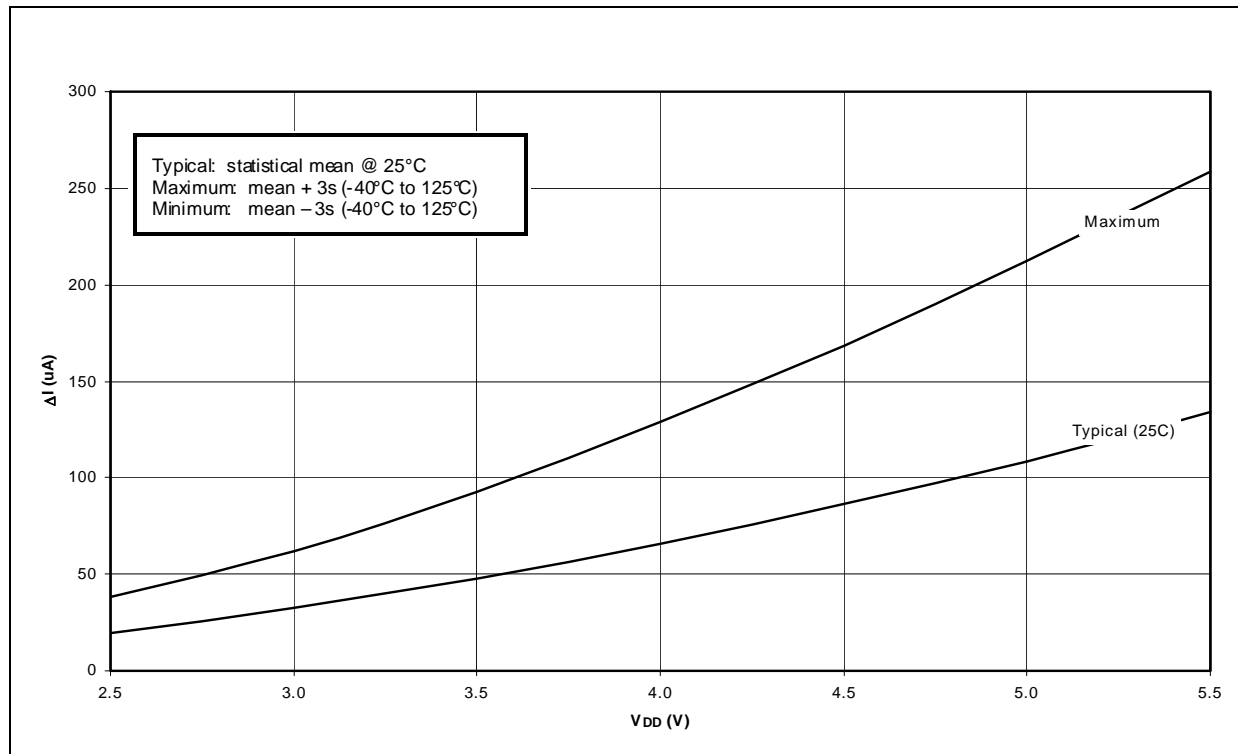

FIGURE 21-15: TYPICAL, MINIMUM AND MAXIMUM WDT PERIOD vs. V_{DD} (-40°C TO +125°C)

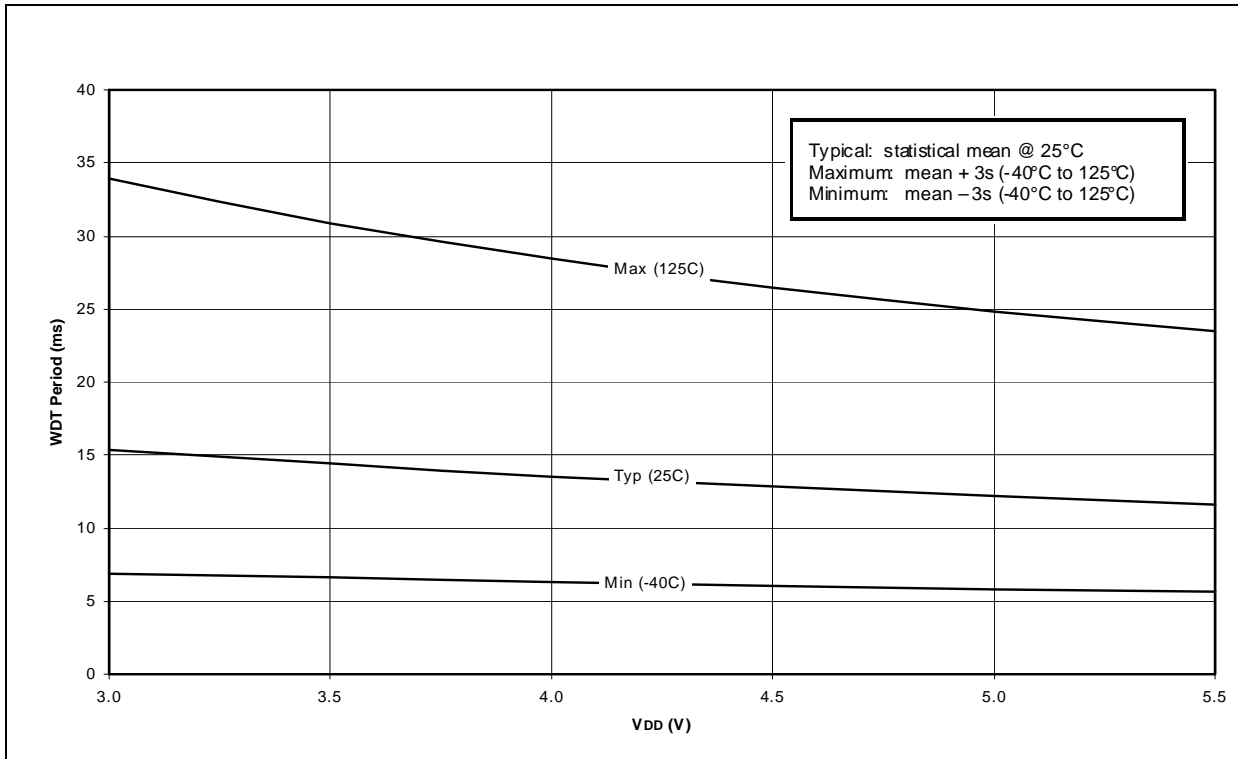
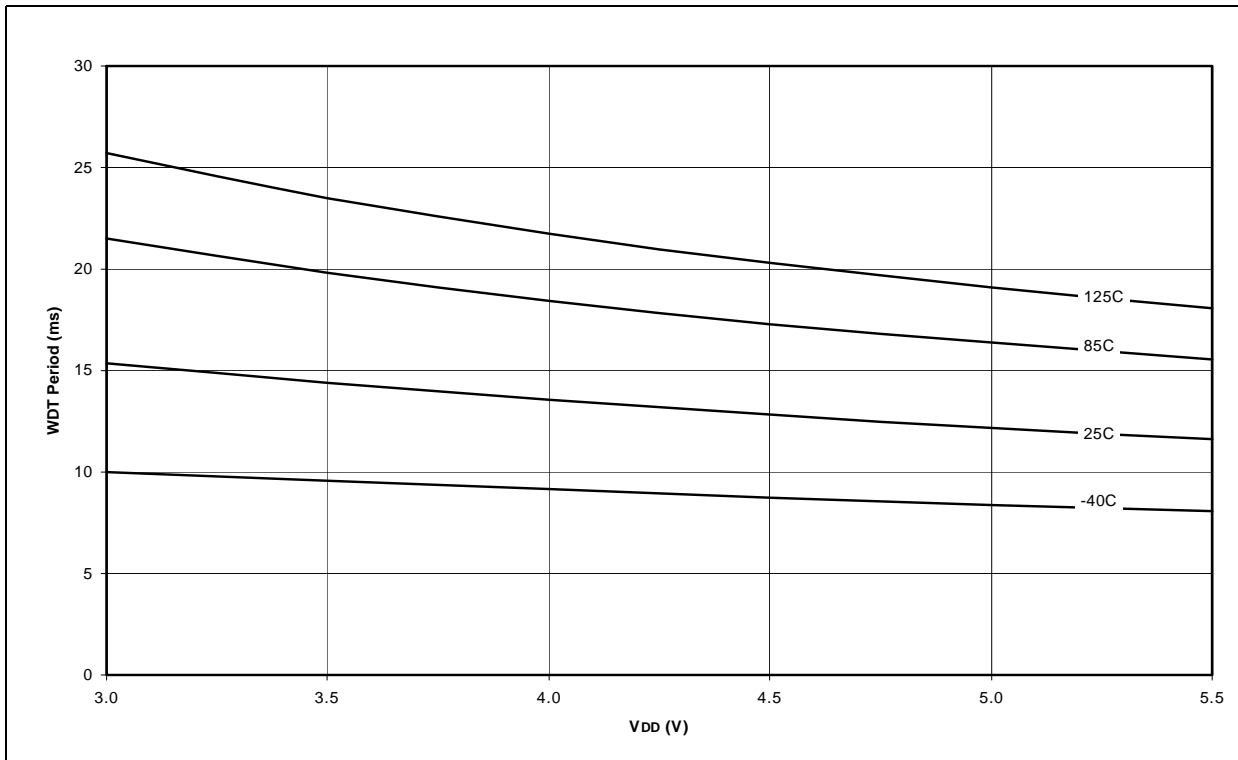

FIGURE 21-16: TYPICAL WDT PERIOD vs. V_{DD} OVER TEMPERATURE (-40°C TO +125°C)



PIC17C7XX

FIGURE 21-17: TYPICAL, MINIMUM AND MAXIMUM V_{OH} vs. I_{OH} ($V_{DD} = 5V$, $-40^{\circ}C$ TO $+125^{\circ}C$)

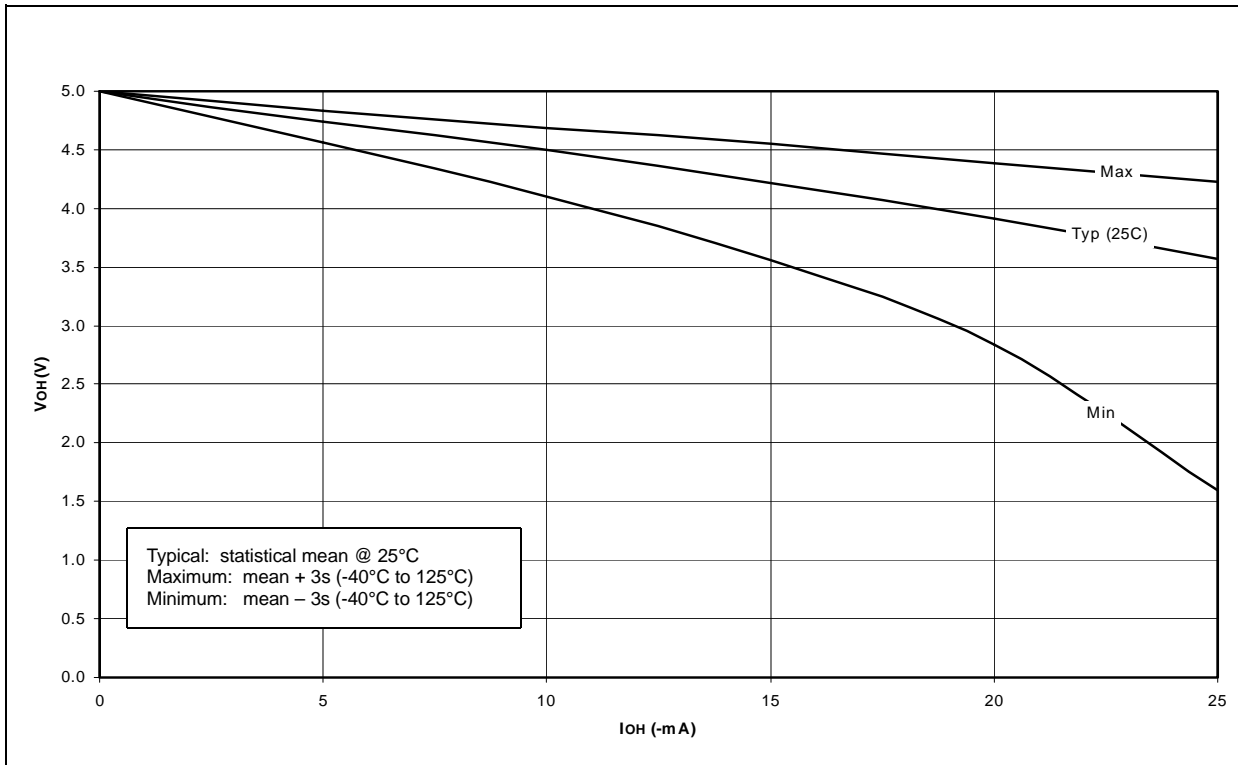

FIGURE 21-18: TYPICAL, MINIMUM AND MAXIMUM V_{OL} vs. I_{OL} ($V_{DD} = 5V$, $-40^{\circ}C$ TO $+125^{\circ}C$)

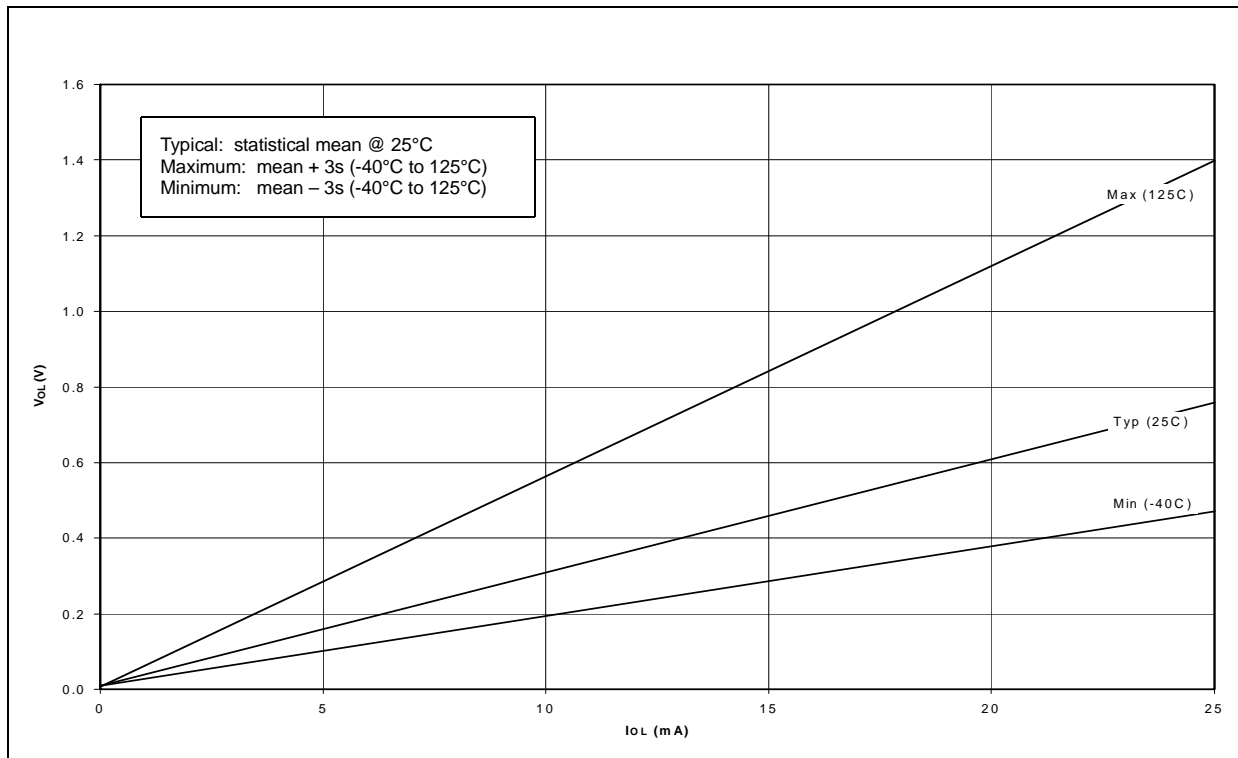

FIGURE 21-19: TYPICAL, MINIMUM AND MAXIMUM V_{OH} vs. I_{OH} ($V_{DD} = 3V$, $-40^{\circ}C$ TO $+125^{\circ}C$)

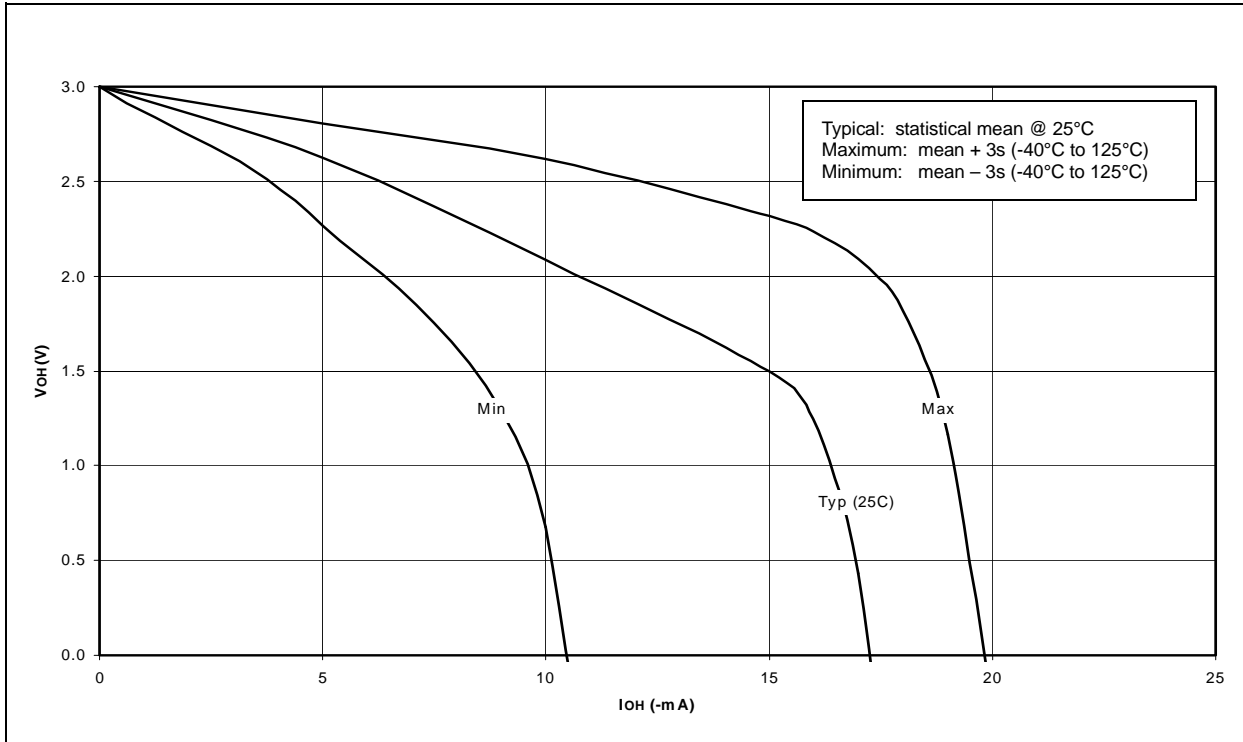
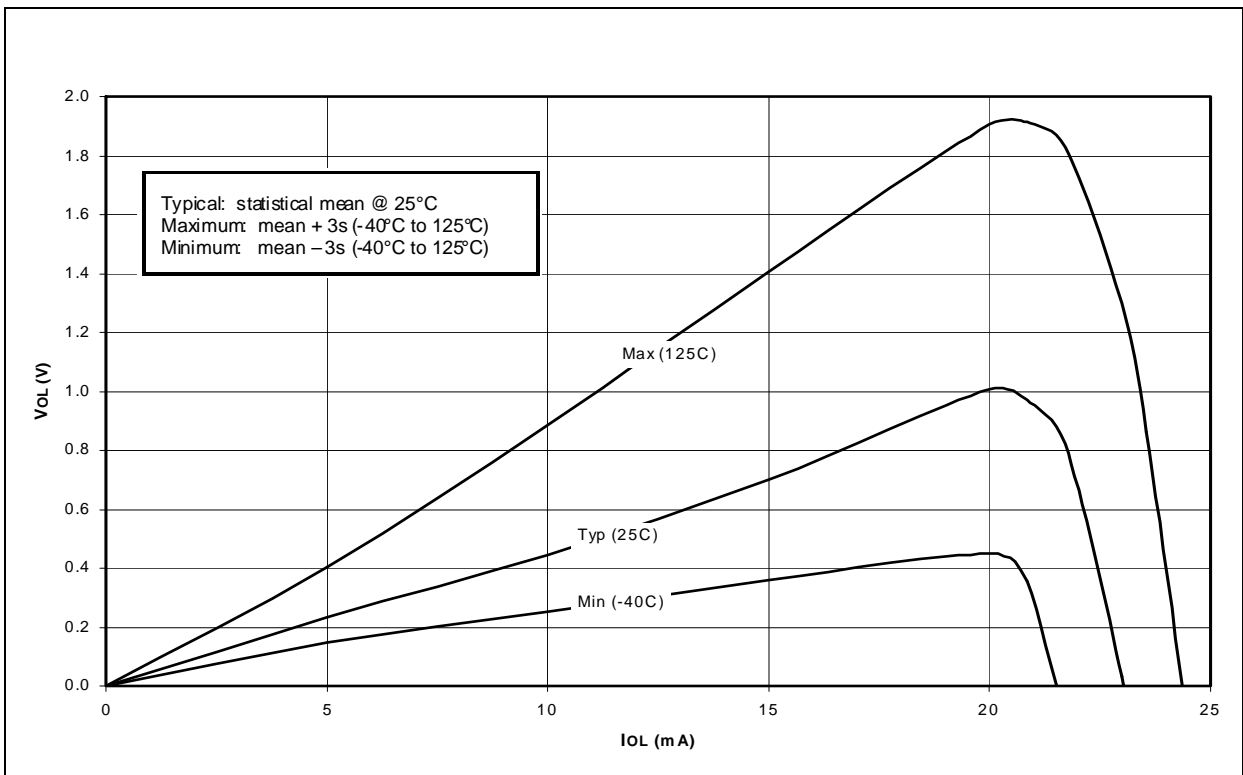

FIGURE 21-20: TYPICAL, MINIMUM AND MAXIMUM V_{OL} vs. I_{OL} ($V_{DD} = 3V$, $-40^{\circ}C$ TO $+125^{\circ}C$)



PIC17C7XX

FIGURE 21-21: TYPICAL, MAXIMUM AND MINIMUM V_{IN} vs. V_{DD} (TTL INPUT, -40°C to 125°C)

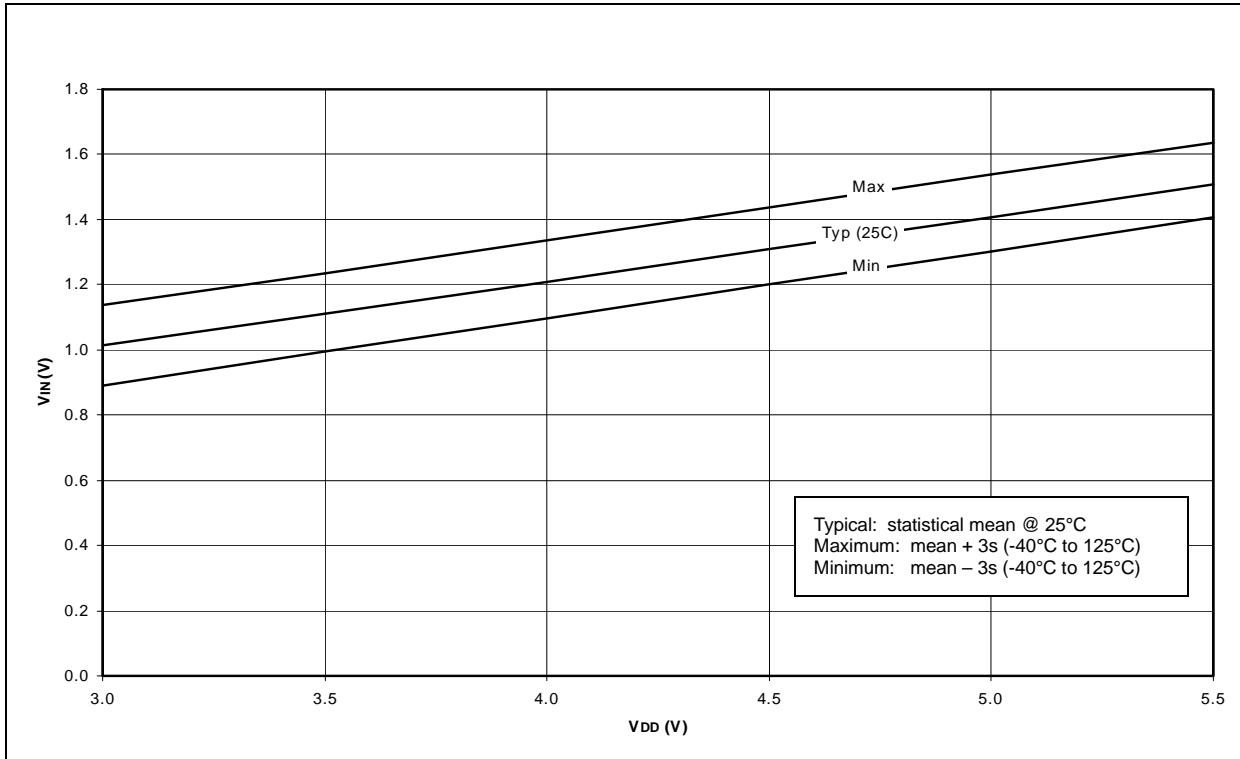

FIGURE 21-22: MAXIMUM AND MINIMUM V_{IN} vs. V_{DD} (ST Input, -40°C to $+125^{\circ}\text{C}$)

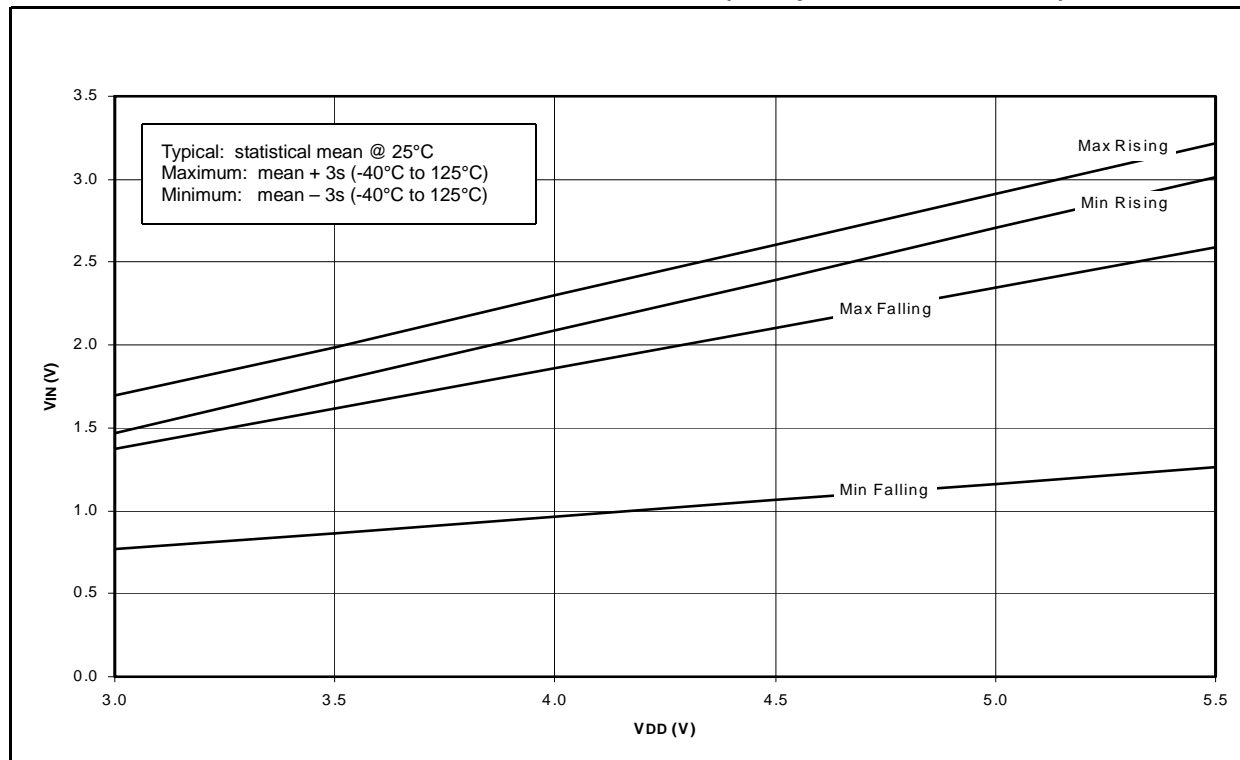
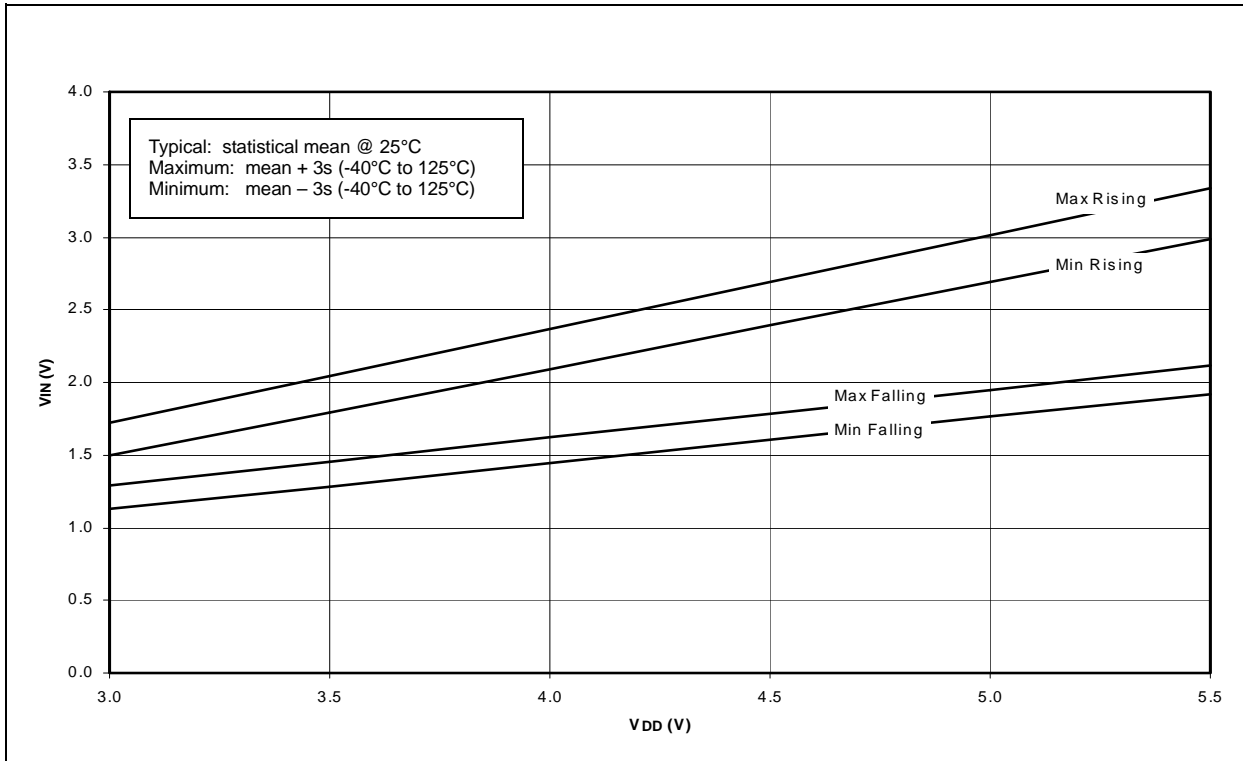

FIGURE 21-23: MAXIMUM AND MINIMUM V_{IN} vs. V_{DD} (I^2C Input, -40°C to $+125^{\circ}\text{C}$)



PIC17C7XX

NOTES:

22.0 PACKAGING INFORMATION

22.1 Package Marking Information

64-Lead TQFP

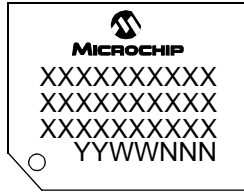

Example

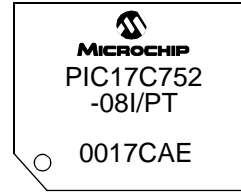

68-Lead PLCC

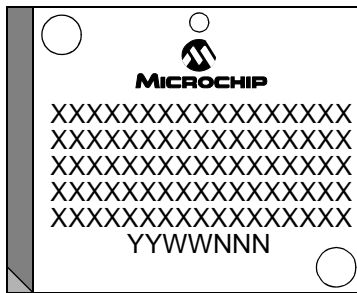

Example

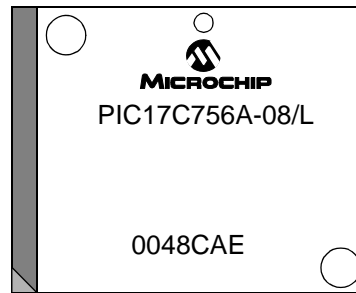

80-Lead TQFP

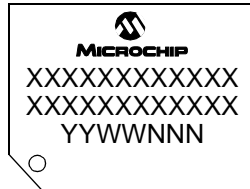

Example

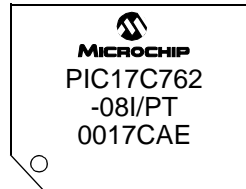

Legend:	XX...X	Customer-specific information
	Y	Year code (last digit of calendar year)
	YY	Year code (last 2 digits of calendar year)
	WW	Week code (week of January 1 is week '01')
	NNN	Alphanumeric traceability code
	(e3)	Pb-free JEDEC designator for Matte Tin (Sn)
	*	This package is Pb-free. The Pb-free JEDEC designator (e3) can be found on the outer packaging for this package.

Note: In the event the full Microchip part number cannot be marked on one line, it will be carried over to the next line, thus limiting the number of available characters for customer-specific information.

PIC17C7XX

Package Marking Information (Cont.)

84-Lead PLCC

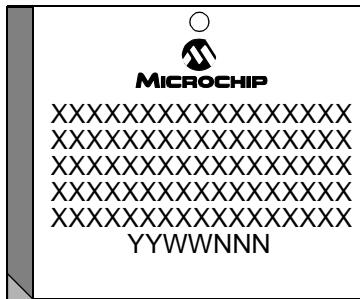

Example

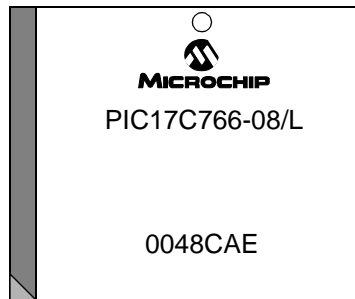

64-Lead Plastic Thin Quad Flatpack (PT) 10x10x1 mm Body, 1.0/0.10 mm Lead Form (TQFP)

Note: For the most current package drawings, please see the Microchip Packaging Specification located at <http://www.microchip.com/packaging>

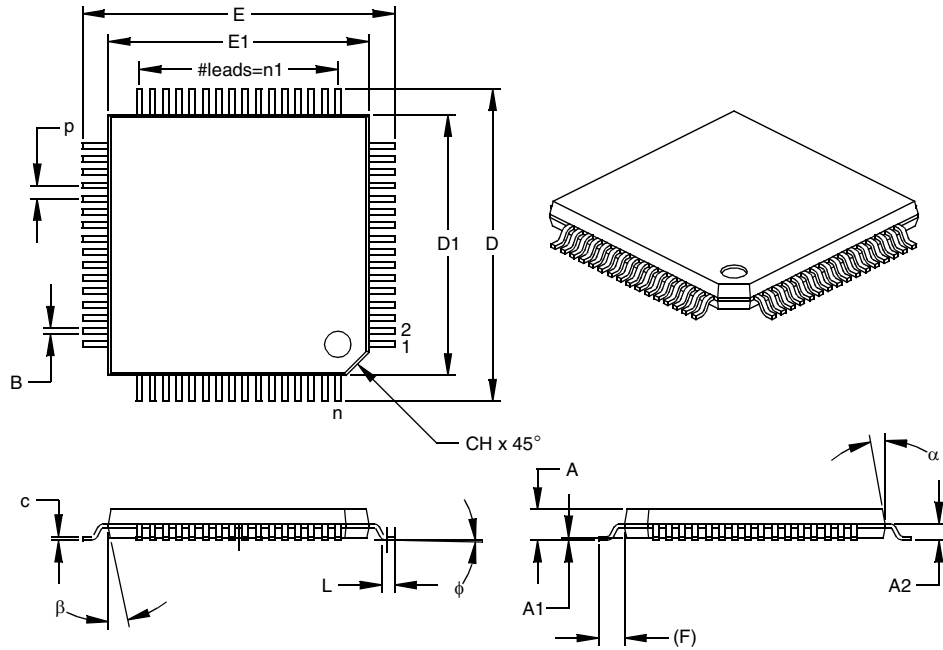

Units		INCHES			MILLIMETERS*		
Dimension Limits		MIN	NOM	MAX	MIN	NOM	MAX
Number of Pins	n		64			64	
Pitch	p		.020			0.50	
Pins per Side	n1		16			16	
Overall Height	A	.039	.043	.047	1.00	1.10	1.20
Molded Package Thickness	A2	.037	.039	.041	0.95	1.00	1.05
Standoff §	A1	.002	.006	.010	0.05	0.15	0.25
Foot Length	L	.018	.024	.030	0.45	0.60	0.75
Footprint (Reference)	(F)		.039			1.00	
Foot Angle	φ	0	3.5	7	0	3.5	7
Overall Width	E	.463	.472	.482	11.75	12.00	12.25
Overall Length	D	.463	.472	.482	11.75	12.00	12.25
Molded Package Width	E1	.390	.394	.398	9.90	10.00	10.10
Molded Package Length	D1	.390	.394	.398	9.90	10.00	10.10
Lead Thickness	c	.005	.007	.009	0.13	0.18	0.23
Lead Width	B	.007	.009	.011	0.17	0.22	0.27
Pin 1 Corner Chamfer	CH	.025	.035	.045	0.64	0.89	1.14
Mold Draft Angle Top	α	5	10	15	5	10	15
Mold Draft Angle Bottom	β	5	10	15	5	10	15

* Controlling Parameter
 § Significant Characteristic

Notes:

Dimensions D1 and E1 do not include mold flash or protrusions. Mold flash or protrusions shall not exceed .010" (0.254mm) per side.

JEDEC Equivalent: MS-026

Drawing No. C04-085

PIC17C7XX

68-Lead Plastic Leaded Chip Carrier (L) – Square (PLCC)

Note: For the most current package drawings, please see the Microchip Packaging Specification located at <http://www.microchip.com/packaging>

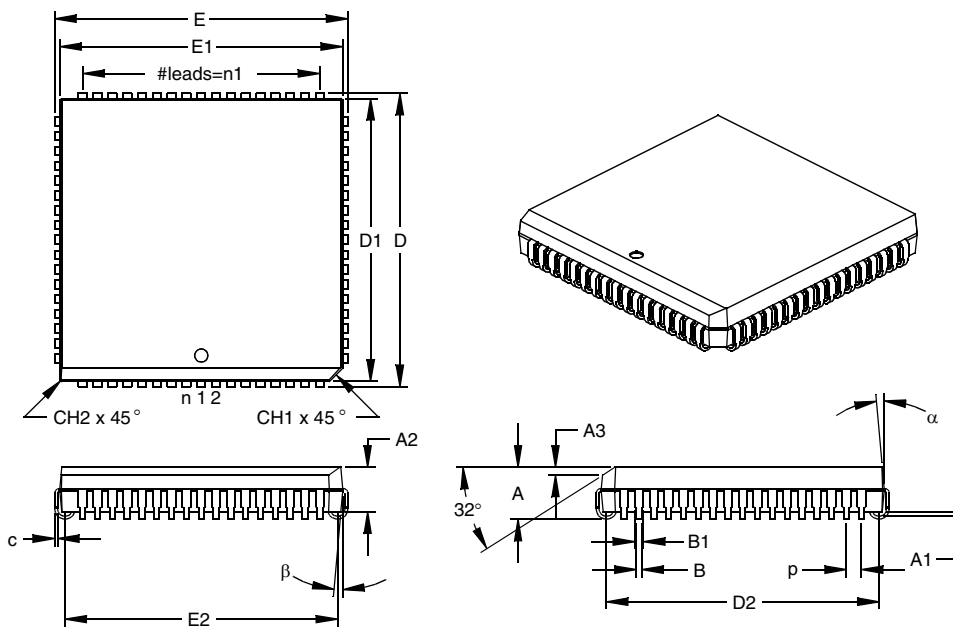

Dimension Limits	Units	INCHES*			MILLIMETERS		
		MIN	NOM	MAX	MIN	NOM	MAX
Number of Pins	n		68			68	
Pitch	p		.050			1.27	
Pins per Side	n1		17			17	
Overall Height	A	.165	.173	.180	4.19	4.39	4.57
Molded Package Thickness	A2	.145	.153	.160	3.68	3.87	4.06
Standoff §	A1	.020	.028	.035	0.51	0.71	0.89
Side 1 Chamfer Height	A3	.024	.029	.034	0.61	0.74	0.86
Corner Chamfer 1	CH1	.040	.045	.050	1.02	1.14	1.27
Corner Chamfer (others)	CH2	.000	.005	.010	0.00	0.13	0.25
Overall Width	E	.985	.990	.995	25.02	25.15	25.27
Overall Length	D	.985	.990	.995	25.02	25.15	25.27
Molded Package Width	E1	.950	.954	.958	24.13	24.23	24.33
Molded Package Length	D1	.950	.954	.958	24.13	24.23	24.33
Footprint Width	E2	.890	.920	.930	22.61	23.37	23.62
Footprint Length	D2	.890	.920	.930	22.61	23.37	23.62
Lead Thickness	c	.008	.011	.013	0.20	0.27	0.33
Upper Lead Width	B1	.026	.029	.032	0.66	0.74	0.81
Lower Lead Width	B	.013	.020	.021	0.33	0.51	0.53
Mold Draft Angle Top	α	0	5	10	0	5	10
Mold Draft Angle Bottom	β	0	5	10	0	5	10

* Controlling Parameter

§ Significant Characteristic

Notes:

Dimensions D and E1 do not include mold flash or protrusions. Mold flash or protrusions shall not exceed .010" (0.254mm) per side.

JEDEC Equivalent: MO-047

Drawing No. C04-049

80-Lead Plastic Thin Quad Flatpack (PT) 12x12x1 mm Body, 1.0/0.10 mm Lead Form (TQFP)

Note: For the most current package drawings, please see the Microchip Packaging Specification located at <http://www.microchip.com/packaging>

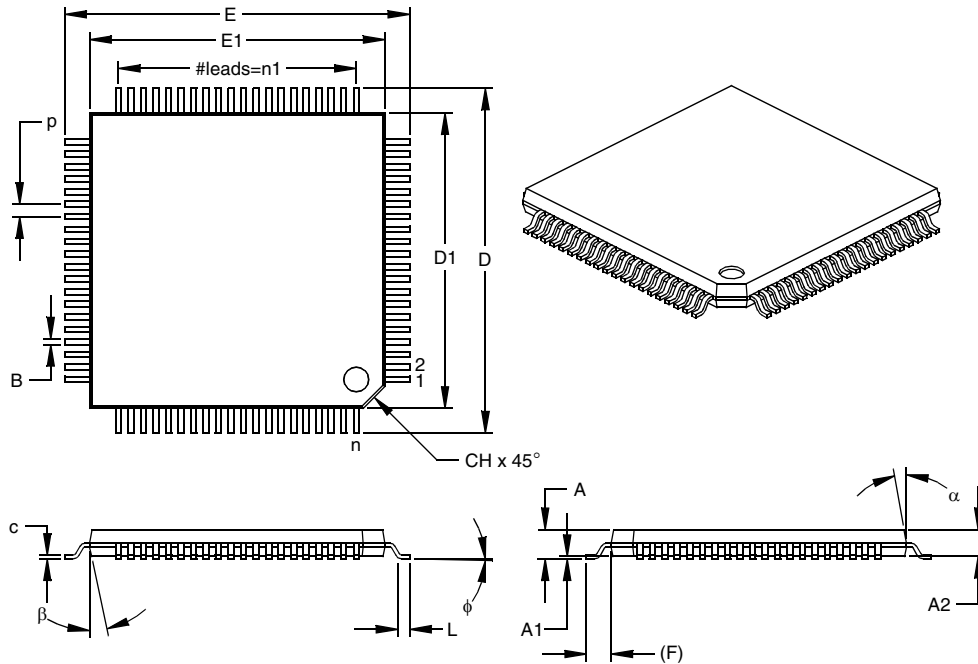

Dimension Limits	Units	INCHES			MILLIMETERS*		
		MIN	NOM	MAX	MIN	NOM	MAX
Number of Pins	n		80			80	
Pitch	p		.020			0.50	
Pins per Side	n1		20			20	
Overall Height	A	.039	.043	.047	1.00	1.10	1.20
Molded Package Thickness	A2	.037	.039	.041	0.95	1.00	1.05
Standoff §	A1	.002	.004	.006	0.05	0.10	0.15
Foot Length	L	.018	.024	.030	0.45	0.60	0.75
Footprint (Reference)	(F)		.039			1.00	
Foot Angle	φ	0	3.5	7	0	3.5	7
Overall Width	E	.541	.551	.561	13.75	14.00	14.25
Overall Length	D	.541	.551	.561	13.75	14.00	14.25
Molded Package Width	E1	.463	.472	.482	11.75	12.00	12.25
Molded Package Length	D1	.463	.472	.482	11.75	12.00	12.25
Lead Thickness	c	.004	.006	.008	0.09	0.15	0.20
Lead Width	B	.007	.009	.011	0.17	0.22	0.27
Pin 1 Corner Chamfer	CH	.025	.035	.045	0.64	0.89	1.14
Mold Draft Angle Top	α	5	10	15	5	10	15
Mold Draft Angle Bottom	β	5	10	15	5	10	15

* Controlling Parameter
 § Significant Characteristic

Notes:
 Dimensions D1 and E1 do not include mold flash or protrusions. Mold flash or protrusions shall not exceed .010" (0.254mm) per side.
 JEDEC Equivalent: MS-026
 Drawing No. C04-092

PIC17C7XX

84-Lead Plastic Leaded Chip Carrier (L) – Square (PLCC)

Note: For the most current package drawings, please see the Microchip Packaging Specification located at <http://www.microchip.com/packaging>

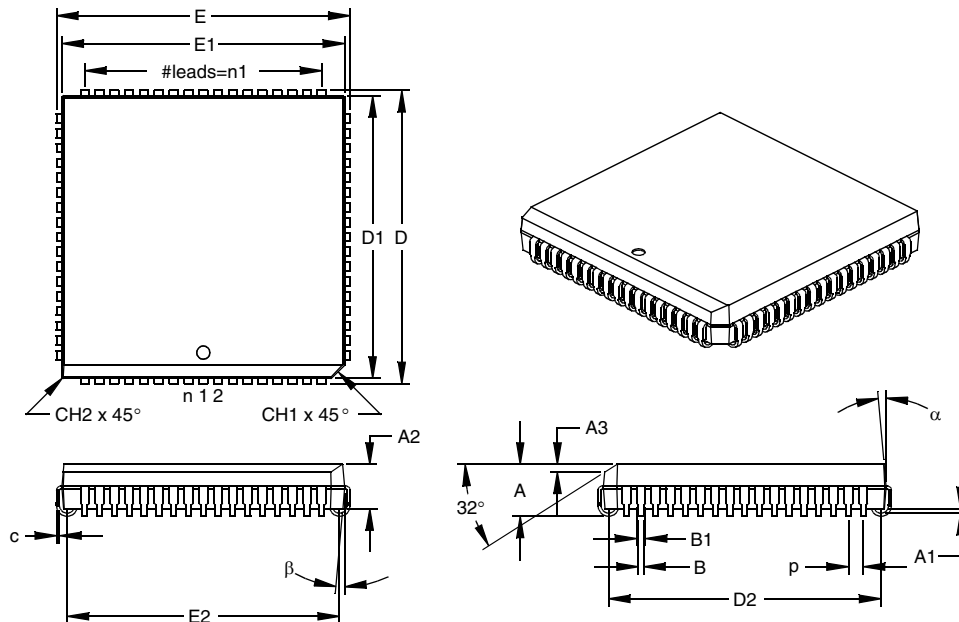

Units		INCHES*			MILLIMETERS		
Dimension Limits		MIN	NOM	MAX	MIN	NOM	MAX
Number of Pins	n		68			68	
Pitch	p		.050			1.27	
Pins per Side	n1		17			17	
Overall Height	A	.165	.173	.180	4.19	4.39	4.57
Molded Package Thickness	A2	.145	.153	.160	3.68	3.87	4.06
Standoff §	A1	.020	.028	.035	0.51	0.71	0.89
Side 1 Chamfer Height	A3	.024	.029	.034	0.61	0.74	0.86
Corner Chamfer 1	CH1	.040	.045	.050	1.02	1.14	1.27
Corner Chamfer (others)	CH2	.000	.005	.010	0.00	0.13	0.25
Overall Width	E	.985	.990	.995	25.02	25.15	25.27
Overall Length	D	.985	.990	.995	25.02	25.15	25.27
Molded Package Width	E1	.950	.954	.958	24.13	24.23	24.33
Molded Package Length	D1	.950	.954	.958	24.13	24.23	24.33
Footprint Width	E2	.890	.920	.930	22.61	23.37	23.62
Footprint Length	D2	.890	.920	.930	22.61	23.37	23.62
Lead Thickness	c	.008	.011	.013	0.20	0.27	0.33
Upper Lead Width	B1	.026	.029	.032	0.66	0.74	0.81
Lower Lead Width	B	.013	.020	.021	0.33	0.51	0.53
Mold Draft Angle Top	α	0	5	10	0	5	10
Mold Draft Angle Bottom	β	0	5	10	0	5	10

* Controlling Parameter

§ Significant Characteristic

Notes:

Dimensions D and E1 do not include mold flash or protrusions. Mold flash or protrusions shall not exceed .010" (0.254mm) per side.

JEDEC Equivalent: MO-047

Drawing No. C04-093

APPENDIX A: MODIFICATIONS

The following is the list of modifications over the PIC16CXX microcontroller family:

1. Instruction word length is increased to 16-bit. This allows larger page sizes, both in program memory (8 Kwords versus 2 Kwords) and register file (256 bytes versus 128 bytes).
2. Four modes of operation: Microcontroller, Protected Microcontroller, Extended Microcontroller, and Microprocessor.
3. 22 new instructions. The `MOVFP`, `TRIS` and `OPTION` instructions are no longer supported.
4. Four new instructions (`TLRD`, `TLWT`, `TABLRD`, `TABLWT`) for transferring data between data memory and program memory. They can be used to “self program” the EPROM program memory.
5. Single cycle data memory to data memory transfers possible (`MOVFPF` and `MOVFP` instructions). These instructions do not affect the Working register (WREG).
6. W register (WREG) is now directly addressable.
7. A PC high latch register (PCLATH) is extended to 8-bits. The PCLATCH register is now both readable and writable.
8. Data memory paging is redefined slightly.
9. DDR registers replace function of TRIS registers.
10. Multiple Interrupt vectors added. This can decrease the latency for servicing interrupts.
11. Stack size is increased to 16 deep.
12. BSR register for data memory paging.
13. Wake-up from SLEEP operates slightly differently.
14. The Oscillator Start-Up Timer (OST) and Power-Up Timer (PWRT) operate in parallel and not in series.
15. PORTB interrupt-on-change feature works on all eight port pins.
16. TMR0 is 16-bit, plus 8-bit prescaler.
17. Second indirect addressing register added (FSR1 and FSR2). Control bits can select the FSR registers to auto-increment, auto-decrement, remain unchanged after an indirect address.
18. Hardware multiplier added (8 x 8 → 16-bit).
19. Peripheral modules operate slightly differently.
20. A/D has both VREF+ and VREF- inputs.
21. USARTs do not implement BRGH feature.
22. Oscillator modes slightly redefined.
23. Control/Status bits and registers have been placed in different registers and the control bit for globally enabling interrupts has inverse polarity.
24. In-circuit serial programming is implemented differently.

APPENDIX B: COMPATIBILITY

To convert code written for PIC16CXXX to PIC17CXXX, the user should take the following steps:

1. Remove any `TRIS` and `OPTION` instructions, and implement the equivalent code.
 2. Separate the Interrupt Service Routine into its four vectors.
 3. Replace:

```
MOVFP    REG1, W
```

 with:

```
MOVFPF   REG1, WREG
```
 4. Replace:

```
MOVFP    REG1, W
```

```
MOVWFP   REG2
```

 with:

```
MOVFPF   REG1, REG2 ; Addr(REG1) < 20h
```

 or

```
MOVFPF   REG1, REG2 ; Addr(REG2) < 20h
```
- Note:** If REG1 and REG2 are both at addresses greater than 20h, two instructions are required.

```
MOVFPF   REG1, WREG ;
```

```
MOVFPF   WREG, REG2 ;
```
5. Ensure that all bit names and register names are updated to new data memory map locations.
 6. Verify data memory banking.
 7. Verify mode of operation for indirect addressing.
 8. Verify peripheral routines for compatibility.
 9. Weak pull-ups are enabled on RESET.
 10. WDT time-outs always reset the device (in run or SLEEP mode).

B.1 Upgrading from PIC17C42 Devices

To convert code from the PIC17C42 to all the other PIC17CXXX devices, the user should take the following steps.

1. If the hardware multiply is to be used, ensure that any variables at address 18h and 19h are moved to another address.
2. Ensure that the upper nibble of the BSR was not written with a non-zero value. This may cause unexpected operation since the RAM bank is no longer 0.
3. The disabling of global interrupts has been enhanced, so there is no additional testing of the GLINTD bit after a `BSF CPUSTA, GLINTD` instruction.

PIC17C7XX

APPENDIX C: WHAT'S NEW

This is a new Data Sheet for the Following Devices:

- PIC17C752
- PIC17C756A
- PIC17C762
- PIC17C766

This Data Sheet is based on the PIC17C75X Data Sheet (DS30246A).

APPENDIX D: WHAT'S CHANGED

Clarified the TAD vs. device maximum operating frequency tables in Section 16.2.

Added device characteristic graphs and charts in Section 21.

Removed the "Preliminary" status from the entire document.

Revision C (January 2013)

Added a note to each package outline drawing.

INDEX

A

A/D	
Accuracy/Error	189
ADCON0 Register	179
ADCON1 Register	180
ADIF bit	181
Analog Input Model Block Diagram	184
Analog-to-Digital Converter	179
Block Diagram	181
Configuring Analog Port Pins	186
Configuring the Interrupt	181
Configuring the Module	181
Connection Considerations	189
Conversion Clock	185
Conversions	186
Converter Characteristics	263
Delays	183
Effects of a RESET	188
Equations	183
Flow Chart of A/D Operation	187
GO/DONE bit	181
Internal Sampling Switch (R _{ss}) Impedence	183
Operation During SLEEP	188
Sampling Requirements	183
Sampling Time	183
Source Impedence	183
Time Delays	183
Transfer Function	189
A/D Interrupt	38
A/D Interrupt Flag bit, ADIF	38
A/D Module Interrupt Enable, ADIE	36
ACK	144
Acknowledge Data bit, AKD	136
Acknowledge Pulse	144
Acknowledge Sequence Enable bit, AKE	136
Acknowledge Status bit, AKS	136
ADCON0	49
ADCON1	49
ADDLW	202
ADDWF	202
ADDWFC	203
ADIE	36
ADIF	38
ADRES Register	179
ADRESH	49
ADRESL	49
AKD	136
AKE	136
AKS	136, 159
ALU	11
ALUSTA	198
ALUSTA Register	51
ANDLW	203
ANDWF	204
Application Note AN552, 'Implementing Wake-up on Keystroke.'	74
Application Note AN578, 'Use of the SSP Module in the I ² C Multi-Master Environment.'	143
Assembler	
MPASM Assembler	233
Asynchronous Master Transmission	123
Asynchronous Transmitter	123

B

Bank Select Register (BSR)	57
Banking	46, 57
Baud Rate Formula	120
Baud Rate Generator	153
Baud Rate Generator (BRG)	120
Baud Rates	
Asynchronous Mode	122
Synchronous Mode	121
BCF	204
BCLIE	36
BCLIF	38
BF	134, 144, 159, 162
Bit Manipulation	198
Block Diagrams	
A/D	181
Analog Input Model	184
Baud Rate Generator	153
BSR Operation	57
External Brown-out Protection Circuit (Case1)	31
External Power-on Reset Circuit	24
External Program Memory Connection	45
I ² C Master Mode	151
I ² C Module	143
Indirect Addressing	54
On-chip Reset Circuit	23
PORTD	80
PORTE	82, 90, 91
Program Counter Operation	56
PWM	107
RA0 and RA1	72
RA2	72
RA3	73
RA4 and RA5	73
RB3:RB2 Port Pins	75
RB7:RB4 and RB1:RB0 Port Pins	74
RC7:RC0 Port Pins	78
SSP (I ² C Mode)	143
SSP (SPI Mode)	137
SSP Module (I ² C Master Mode)	133
SSP Module (I ² C Slave Mode)	133
SSP Module (SPI Mode)	133
Timer3 with One Capture and One Period Register	110
TMR1 and TMR2 in 16-bit Timer/Counter Mode	105
TMR1 and TMR2 in Two 8-bit Timer/Counter Mode	104
TMR3 with Two Capture Registers	112
Using CALL, GOTO	56
WDT	193
BODEN	31
Borrow	11
BRG	120, 153
Brown-out Protection	31
Brown-out Reset (BOR)	31
BSF	205
BSR	57
BSR Operation	57
BTFSC	205
BTFSS	206
BTG	206
Buffer Full bit, BF	144
Buffer Full Status bit, BF	134
Bus Arbitration	170
Bus Collision	
Section	170

PIC17C7XX

Bus Collision During a RESTART Condition	173	Configuration	
Bus Collision During a START Condition	171	Bits	192
Bus Collision During a STOP Condition	174	Locations	192
Bus Collision Interrupt Enable, BCLIE	36	Oscillator	17, 192
Bus Collision Interrupt Flag bit, BCLIF	38	Word	191
C		CPFSEQ	209
C	11, 51	CPFSGT	209
CA1/PR3	102	CPFSLT	210
CA1ED0	101	CPUSTA	52, 194
CA1ED1	101	Crystal Operation, Overtone Crystals	18
CA1IE	35	Crystal or Ceramic Resonator Operation	18
CA1IF	37	Crystal Oscillator	17
CA1OVF	102	D	
CA2ED0	101	D/Ā	134
CA2ED1	101	Data Memory	
CA2H	28, 49	GPR	43, 46
CA2IE	35, 111	Indirect Addressing	54
CA2IF	37, 111	Organization	46
CA2L	28, 49	SFR	43
CA2OVF	102	Data Memory Banking	46
CA3H	50	Data/Address bit, D/Ā	134
CA3IE	36	DAW	210
CA3IF	38	DC	11, 51
CA3L	50	DDRB	27, 48, 74
CA4H	50	DDRC	28, 48, 78
CA4IE	36	DDRD	28, 48, 80
CA4IF	38	DDRE	28, 48, 82
Calculating Baud Rate Error	120	DDRF	49
CALL	54, 207	DDRG	49
Capacitor Selection		DECF	211
Ceramic Resonators	18	DECFSNZ	212
Crystal Oscillator	18	DECFSZ	211
Capture	101, 110	Delay From External Clock Edge	98
Capture Sequence to Read Example	113	Digit Borrow	11
Capture1		Digit Carry (DC)	11
Mode	101	Duty Cycle	107
Overflow	102, 103	E	
Capture1 Interrupt	37	Electrical Characteristics	
Capture2		PIC17C752/756	
Mode	101	Absolute Maximum Ratings	239
Overflow	102, 103	Capture Timing	253
Capture2 Interrupt	37	CLKOUT and I/O Timing	250
Capture3 Interrupt Enable, CA3IE	36	DC Characteristics	242
Capture3 Interrupt Flag bit, CA3IF	38	External Clock Timing	249
Capture4 Interrupt Enable, CA4IE	36	Memory Interface Read Timing	266
Capture4 Interrupt Flag bit, CA4IF	38	Memory Interface Write Timing	265
Carry (C)	11	Parameter Measurement Information	248
Ceramic Resonators	17	Reset, Watchdog Timer, Oscillator Start-up	
Circular Buffer	54	Timer and Power-up Timer Timing	251
CKE	134	Timer0 Clock Timing	252
CKP	135	Timer1, Timer2 and Timer3 Clock Timing	252
Clearing the Prescaler	193	Timing Parameter Symbology	247
Clock Polarity Select bit, CKP	135	USART Module Synchronous Receive Timing	261
Clock/Instruction Cycle (Figure)	21	USART Module Synchronous Transmission	
Clocking Scheme/Instruction Cycle	21	Timing	260
CLRF	207	EPROM Memory Access Time Order Suffix	45
CLRWDT	208	Errata	5
Code Examples		Extended Microcontroller	43
Indirect Addressing	55	Extended Microcontroller Mode	45
Loading the SSPBUF register	138	External Memory Interface	45
Saving Status and WREG in RAM	42	External Program Memory Waveforms	45
Table Read	64		
Table Write	62		
Code Protection	195		
COMF	208		

F		
Family of Devices		
PIC17C75X.....	8	
FERR	125	
Flowcharts		
Acknowledge.....	166	
Master Receiver.....	163	
Master Transmit.....	160	
RESTART Condition.....	157	
Start Condition.....	155	
STOP Condition.....	168	
FOSC0.....	191	
FOSC1.....	191	
FS0.....	51	
FS1.....	51	
FS2.....	51	
FS3.....	51	
FSR0.....	54	
FSR1.....	54	
G		
GCE.....	136	
General Call Address Sequence.....	149	
General Call Address Support.....	149	
General Call Enable bit, GCE.....	136	
General Format for Instructions.....	198	
General Purpose RAM.....	43	
General Purpose RAM Bank.....	57	
General Purpose Register (GPR).....	46	
GLINTD.....	39, 52, 111, 194	
Global Interrupt Disable bit, GLINTD.....	39	
GOTO.....	212	
GPR (General Purpose Register).....	46	
GPR Banks.....	57	
Graphs		
RC Oscillator Frequency vs. VDD (CEXT = 100 pF)....	268	
RC Oscillator Frequency vs. VDD (CEXT = 22 pF)....	268	
RC Oscillator Frequency vs. VDD (CEXT = 300 pF)....	269	
Transconductance of LF Oscillator vs. VDD.....	270	
Transconductance of XT Oscillator vs. VDD.....	270	
Typical RC Oscillator vs. Temperature.....	267	
H		
Hardware Multiplier.....	67	
I		
I/O Ports		
Bi-directional.....	93	
I/O Ports.....	71	
Programming Considerations.....	93	
Read-Modify-Write Instructions.....	93	
Successive Operations.....	94	
I ² C.....	143	
I ² C Input.....	279	
I ² C Master Mode Receiver Flow Chart.....	163	
I ² C Master Mode Reception.....	162	
I ² C Master Mode RESTART Condition.....	156	
I ² C Mode Selection.....	143	
I ² C Module		
Acknowledge Flow Chart.....	166	
Acknowledge Sequence Timing.....	165	
Addressing.....	145	
Baud Rate Generator.....	153	
Block Diagram.....	151	
BRG Block Diagram.....	153	
BRG Reset due to SDA Collision.....	172	
BRG Timing.....	153	
Bus Arbitration.....	170	
Bus Collision.....	170	
Acknowledge.....	170	
RESTART Condition.....	173	
RESTART Condition Timing (Case1).....	173	
RESTART Condition Timing (Case2).....	173	
START Condition.....	171	
START Condition Timing.....	171, 172	
STOP Condition.....	174	
STOP Condition Timing (Case1).....	174	
STOP Condition Timing (Case2).....	174	
Transmit Timing.....	170	
Bus Collision Timing.....	170	
Clock Arbitration.....	169	
Clock Arbitration Timing (Master Transmit).....	169	
Conditions to not give ACK Pulse.....	144	
General Call Address Support.....	149	
Master Mode.....	151	
Master Mode 7-bit Reception timing.....	164	
Master Mode Operation.....	152	
Master Mode Start Condition.....	154	
Master Mode Transmission.....	159	
Master Mode Transmit Sequence.....	152	
Master Transmit Flowchart.....	160	
Multi-Master Communication.....	170	
Multi-master Mode.....	152	
Operation.....	143	
Repeat Start Condition timing.....	156	
RESTART Condition Flowchart.....	157	
Slave Mode.....	144	
Slave Reception.....	145	
Slave Transmission.....	146	
SSPBUF.....	144	
Start Condition Flowchart.....	155	
Stop Condition Flowchart.....	168	
Stop Condition Receive or Transmit timing.....	167	
Stop Condition timing.....	167	
Waveforms for 7-bit Reception.....	146	
Waveforms for 7-bit Transmission.....	146	
I ² C Module Address Register, SSPADD.....	144	
I ² C Slave Mode.....	144	
INCF.....	213	
INCFSNZ.....	214	
INCFSZ.....	213	
In-Circuit Serial Programming.....	196	
INDF0.....	54	
INDF1.....	54	
Indirect Addressing		
Indirect Addressing.....	54	
Operation.....	55	
Registers.....	54	
Initializing PORTB.....	75	
Initializing PORTC.....	78	
Initializing PORTD.....	80	
Initializing PORTE.....	82, 84, 86	
INSTA.....	48	
Instruction Flow/Pipelining.....	21	
Instruction Set		
ADDLW.....	202	
ADDWF.....	202	
ADDWFC.....	203	
ANDLW.....	203	
ANDWF.....	204	
BCF.....	204	
BSF.....	205	
BTFSC.....	205	
BTFSS.....	206	

PIC17C7XX

BTG.....	206	Capture4 Interrupt	38
CALL.....	207	Context Saving	39
CLRF.....	207	Flag bits	
CLRWDT.....	208	TMR1IE	33
COMF.....	208	TMR1IF.....	33
CPFSEQ.....	209	TMR2IE	33
CPFSGT.....	209	TMR2IF.....	33
CPFSLT.....	210	TMR3IE	33
DAW.....	210	TMR3IF.....	33
DECF.....	211	Global Interrupt Disable.....	39
DECFSNZ.....	212	Interrupts	33
DECFSZ.....	211	Logic	33
GOTO.....	212	Operation	39
INCF.....	213	Peripheral Interrupt Enable.....	35
INCFSNZ.....	214	Peripheral Interrupt Request.....	37
INCFSZ.....	213	PIE2 Register	36
IORLW.....	214	PIR1 Register	37
IORWF.....	215	PIR2 Register	38
LCALL.....	215	PORTB Interrupt on Change	37
MOVFP.....	216	PWM.....	108
MOVLB.....	216	RA0/INT	39
MOVLR.....	217	Status Register	34
MOVLW.....	217	Synchronous Serial Port Interrupt.....	38
MOVPF.....	218	T0CKI Interrupt	39
MOVWF.....	218	Timing.....	40
MULLW.....	219	TMR1 Overflow Interrupt	37
MULWF.....	219	TMR2 Overflow Interrupt	37
NEGW.....	220	TMR3 Overflow Interrupt	37
NOP.....	220	USART1 Receive Interrupt	37
RETFIE.....	221	USART1 Transmit Interrupt	37
RETLW.....	221	USART2 Receive Interrupt	38
RETURN.....	222	Vectors	
RLCF.....	222	Peripheral Interrupt.....	39
RLNCF.....	223	Program Memory Locations	43
RRCF.....	223	RA0/INT Interrupt	39
RRNCF.....	224	T0CKI Interrupt.....	39
SETF.....	224	Vectors/Priorities.....	39
SLEEP.....	225	Wake-up from SLEEP.....	194
SUBLW.....	225	INTF.....	34
SUBWF.....	226	INTSTA Register.....	34
SUBWFB.....	226	IORLW.....	214
SWAPF.....	227	IORWF.....	215
TABLRD.....	227, 228	IRBPU vs. VDD	274
TABLWT.....	228, 229	K	
TLRD.....	229	KeeLoq Evaluation and Programming Tools	236
TLWT.....	230	L	
TSTFSZ.....	230	LCALL.....	54, 215
XORLW.....	231	M	
XORWF.....	231	Maps	
Instruction Set Summary.....	197	Register File Map.....	47
Instructions		Memory	
TABLRD.....	64	External Interface	45
TLRD.....	64	External Memory Waveforms	45
INT Pin.....	40	Memory Map (Different Modes).....	44
INTE.....	34	Mode Memory Access	44
INTEDG.....	53, 97	Organization	43
Inter-Integrated Circuit (I ² C).....	133	Program Memory	43
Internal Sampling Switch (R _{ss}) Impedance	183	Program Memory Map	43
Interrupt on Change Feature.....	74	Microcontroller	43
Interrupt Status Register (INTSTA)	34	Microprocessor	43
Interrupts		Minimizing Current Consumption.....	195
A/D Interrupt.....	38	MOVFP	46, 216
Bus Collision Interrupt.....	38	Moving Data Between Data and Program Memories	46
Capture1 Interrupt.....	37	MOVLB	46, 216
Capture2 Interrupt.....	37	MOVLR.....	217
Capture3 Interrupt.....	38	MOVLW	217

MOVPF	46, 218	PORTB	27, 48, 74
MOVWF	218	PORTB Interrupt on Change	37
MPLAB Integrated Development Environment Software ..	233	PORTC	28, 48, 78
MULLW	219	PORTD	28, 48, 80
Multi-Master Communication	170	PORTE	28, 48, 82
Multi-Master Mode	152	PORTF	49
Multiply Examples		PORTG	49
16 x 16 Routine	68	Power-down Mode	194
16 x 16 Signed Routine	69	Power-on Reset (POR)	24
8 x 8 Routine	67	Power-up Timer (PWRT)	24
8 x 8 Signed Routine	67	PR1	28, 49
MULWF	219	PR2	28, 49
N		PR3/CA1H	28
NEGW	220	PR3/CA1L	28
NOP	220	PR3H/CA1H	49
O		PR3L/CA1L	49
Opcode Field Descriptions	197	Prescaler Assignments	99
Opcodes	56	PRO MATE™ II Universal Programmer	235
Oscillator		PRODH	30, 50
Configuration	17, 192	PRODL	30, 50
Crystal	17	Program Counter (PC)	56
External Clock	19	Program Memory	
External Crystal Circuit	19	External Access Waveforms	45
External Parallel Resonant Crystal Circuit	19	External Connection Diagram	45
External Series Resonant Crystal Circuit	19	Map	43
RC	20	Modes	
RC Frequencies	269	Extended Microcontroller	43
Oscillator Start-up Time (Figure)	24	Microcontroller	43
Oscillator Start-up Timer (OST)	24	Microprocessor	43
OST	24	Protected Microcontroller	43
OV	11, 51	Operation	43
Overflow (OV)	11	Organization	43
P		Protected Microcontroller	43
P	134	PS0	53, 97
Packaging Information	281	PS1	53, 97
PC (Program Counter)	56	PS2	53, 97
PCFG0 bit	180	PS3	53, 97
PCFG1 bit	180	PUSH	39, 54
PCFG2 bit	180	PW1DCH	28, 49
PCH	56	PW1DCL	28, 49
PCL	56, 198	PW2DCH	28, 49
PCLATH	56	PW2DCL	28, 49
PD	52, 194	PW3DCH	30, 50
PEIE	34, 111	PW3DCL	30, 50
PEIF	34	PWM	101, 107
Peripheral Bank	57	Duty Cycle	108
Peripheral Banks	57	External Clock Source	109
Peripheral Interrupt Enable	35	Frequency vs. Resolution	108
Peripheral Interrupt Request (PIR1)	37	Interrupts	108
Peripheral Register Banks	46	Max Resolution/Frequency for External Clock Input ..	109
PICDEM-1 Low-Cost PICmicro Demo Board	235	Output	107
PICDEM-2 Low-Cost PIC16CXX Demo Board	235	Periods	108
PICDEM-3 Low-Cost PIC16CXXX Demo Board	236	PWM1	102, 103
PICSTART™ Plus Entry Level Development System	235	PWM1ON	102, 107
PIE	126, 130, 132	PWM2	102, 103
PIE1	28, 48	PWM2ON	102, 107
PIE2	28, 36, 49	PWM3ON	103
PIR	126, 130, 132	PWRT	24
PIR1	28, 48		
PIR2	28, 49		
PM0	191, 195		
PM1	191, 195		
POP	39, 54		
POR	24		
PORTA	27, 48, 72		

PIC17C7XX

R		
R/W	134
R/W bit	145
R/W bit	145
RA1/T0CKI pin	97
RBIE	35
RBIF	37
RBPU	74
RC Oscillator	20
RC Oscillator Frequencies	269
RC1IE	35
RC1IF	37
RC2IE	36
RC2IF	38
RCE, Receive Enable bit, RCE	136
RCREG 125, 126, 130, 131	
RCREG1	27, 48
RCREG2	27, 49
RCSTA 126, 130, 132	
RCSTA1	27, 48
RCSTA2	27, 49
Read/Write bit, R/W	134
Reading 16-bit Value	99
Receive Overflow Indicator bit, SSPOV	135
Receive Status and Control Register	117
Register File Map	47
Registers		
ADCON0	49
ADCON1	49
ADRESH	49
ADRESL	49
ALUSTA 39, 48, 51	
BRG	120
BSR 39, 48	
CA2H	49
CA2L	49
CA3H	50
CA3L	50
CA4H	50
CA4L	50
CPUSTA 48, 52	
DDRB	48
DDRC	48
DDRD	48
DDRE	48
DDRF	49
DDRG	49
FSR0 48, 54	
FSR1 48, 54	
INDF0 48, 54	
INDF1 48, 54	
INSTA	48
INTSTA	34
PCL	48
PCLATH	48
PIE1 35, 48	
PIE2 36, 49	
PIR1 37, 48	
PIR2 38, 49	
PORTA	48
PORTB	48
PORTC	48
PORTD	48
PORTE	48
PORTF	49
PORTG	49
PR1	49
PR2	49
PR3H/CA1H	49
PR3L/CA1L	49
PRODH	50
PRODL	50
PW1DCH	49
PW1DCL	49
PW2/DCL	49
PW2DCH	49
PW3DCH	50
PW3DCL	50
RCREG1	48
RCREG2	49
RCSTA1	48
RCSTA2	49
SPBRG1	48
SPBRG2	49
SSPADD	50
SSPBUF	50
SSPCON1	50
SSPCON2	50
SSPSTAT 50, 134	
T0STA 48, 53, 97	
TBLPTRH	48
TBLPTRL	48
TCON1 49, 101	
TCON2 49, 102	
TCON3 50, 103	
TMR0H	48
TMR1	49
TMR2	49
TMR3H	49
TMR3L	49
TXREG1	48
TXREG2	49
TXSTA1	48
TXSTA2	49
WREG 39, 48	
Registers		
TMR0L	48
Reset		
Section	23
Status Bits and Their Significance	25
Time-Out in Various Situations	25
Time-Out Sequence	25
Restart Condition Enabled bit, RSE	136
RETFIE	221
RETLW	221
RETURN	222
RLCF	222
RLNCF	223
RRCF	223
RRNCF	224
RSE	136
RX Pin Sampling Scheme	125
S		
S	134
SAE	136
Sampling	125
Saving STATUS and WREG in RAM	42
SCK	137
SCL	144
SDA	144
SDI	137
SDO	137

SEEVAL Evaluation and Programming System.....	236	SSPIE	36
Serial Clock, SCK	137	SSPIF	38, 145
Serial Clock, SCL.....	144	SSPM3:SSPM0	135
Serial Data Address, SDA.....	144	SSPOV	135, 144, 162
Serial Data In, SDI	137	SSPSTAT	50, 134, 144
Serial Data Out, SDO.....	137	ST Input	278
SETF	224	Stack	
SFR	198	Operation	54
SFR (Special Function Registers).....	43	Pointer	54
SFR As Source/Destination	198	Stack.....	43
Signed Math.....	11	START bit (S)	134
Slave Select Synchronization	140	START Condition Enabled bit, SAE.....	136
Slave Select, \overline{SS}	137	STKAV	52, 54
SLEEP	194, 225	STOP bit (P)	134
SLEEP Mode, All Peripherals Disabled	273	STOP Condition Enable bit.....	136
SLEEP Mode, BOR Enabled	273	SUBLW	225
SMP	134	SUBWF	226
Software Simulator (MPLAB SIM).....	234	SUBWFB	226
SPBRG	126, 130, 132	SWAPF	227
SPBRG1	27, 48	Synchronous Master Mode.....	127
SPBRG2	27, 49	Synchronous Master Reception.....	129
SPE	136	Synchronous Master Transmission	127
Special Features of the CPU	191	Synchronous Serial Port.....	133
Special Function Registers	43, 198	Synchronous Serial Port Enable bit, SSPEN.....	135
Summary.....	48	Synchronous Serial Port Interrupt.....	38
Special Function Registers, File Map	47	Synchronous Serial Port Interrupt Enable, SSPIE.....	36
SPI		Synchronous Serial Port Mode Select bits,	
Master Mode	139	SSPM3:SSPM0	135
Serial Clock.....	137	Synchronous Slave Mode.....	131
Serial Data In	137	T	
Serial Data Out	137	T0CKI	39
Serial Peripheral Interface (SPI)	133	T0CKI Pin	40
Slave Select.....	137	T0CKIE	34
SPI clock.....	139	T0CKIF	34
SPI Mode	137	T0CS	53, 97
SPI Clock Edge Select, CKE	134	T0IE	34
SPI Data Input Sample Phase Select, SMP	134	T0IF	34
SPI Master/Slave Connection	138	T0SE	53, 97
SPI Module		T0STA	53
Master/Slave Connection.....	138	T16	101
Slave Mode.....	140	Table Latch.....	55
Slave Select Synchronization	140	Table Pointer	55
Slave Synch Timing	140	Table Read	
\overline{SS}	137	Example.....	64
SSP	133	Table Reads Section	64
Block Diagram (SPI Mode)	137	TLRD	64
SPI Mode	137	Table Write	
SSPADD	144, 145	Code	62
SSPBUF.....	139, 144	Timing.....	62
SSPCON1.....	135	To External Memory	62
SSPCON2.....	136	TABLRD	227, 228
SSPSR.....	139, 144	TABLWT	228, 229
SSPSTAT.....	134, 144	TAD	185
SSP I ² C		TBLATH.....	55
SSP I ² C Operation.....	143	TBLATL	55
SSP Module		TBLPTRH	55
SPI Master Mode	139	TBLPTRL	55
SPI Master/Slave Connection.....	138	TCLK12	101
SPI Slave Mode	140	TCLK3	101
SSPCON1 Register	143	TCON1	28, 49
SSP Overflow Detect bit, SSPOV	144	TCON2	49
SSPADD	50	TCON2,TCON3	28
SSPBUF.....	50, 144	TCON3	50, 103
SSPCON1	50, 135, 143	Time-Out Sequence.....	25
SSPCON2.....	50, 136	Timer Resources	95
SSPEN.....	135		

PIC17C7XX

Timer0	97	TMR0	98, 99
Timer1		TMR0 Read/Write in Timer Mode	100
16-bit Mode	105	TMR1, TMR2, and TMR3 in Timer Mode	115
Clock Source Select.....	101	Wake-Up from SLEEP	194
On bit	102, 103	TLRD	229
Section	101, 104	TLWT	230
Timer2		TMR0	
16-bit Mode	105	16-bit Read	99
Clock Source Select.....	101	16-bit Write	99
On bit	102, 103	Module	98
Section	101, 104	Operation	98
Timer3		Overview	95
Clock Source Select.....	101	Prescaler Assignments	99
On bit	102, 103	Read/Write Considerations.....	99
Section	101, 110	Read/Write in Timer Mode.....	100
Timers		Timing.....	98, 99
TCON3.....	103	TMR0 Status/Control Register (T0STA)	53
Timing Diagrams		TMR1	28, 49
A/D Conversion	264	8-bit Mode.....	104
Acknowledge Sequence Timing.....	165	External Clock Input.....	104
Asynchronous Master Transmission.....	123	Overview	95
Asynchronous Reception	126	Timer Mode.....	115
Back to Back Asynchronous Master Transmission	124	Two 8-bit Timer/Counter Mode	104
Baud Rate Generator with Clock Arbitration	153	Using with PWM	107
BRG Reset Due to SDA Collision	172	TMR1 Overflow Interrupt	37
Bus Collision		TMR1CS	101
START Condition Timing	171	TMR1IE.....	35
Bus Collision During a RESTART Condition		TMR1IF.....	37
(Case 1)	173	TMR1ON.....	102
Bus Collision During a RESTART Condition		TMR2	28, 49
(Case 2)	173	8-bit Mode.....	104
Bus Collision During a START Condition		External Clock Input.....	104
(SCL = 0).....	172	In Timer Mode.....	115
Bus Collision During a		Two 8-bit Timer/Counter Mode	104
STOP Condition	174	Using with PWM	107
Bus Collision for Transmit and Acknowledge.....	170	TMR2 Overflow Interrupt	37
External Parallel Resonant Crystal Oscillator Circuit ..	19	TMR2CS	101
External Program Memory Access	45	TMR2IE.....	35
I ² C Bus Data	259	TMR2IF.....	37
I ² C Bus START/STOP bits	258	TMR2ON.....	102
I ² C Master Mode First START bit Timing	154	TMR3	
I ² C Master Mode Reception Timing	164	Example, Reading From	114
I ² C Master Mode Transmission Timing.....	161	Example, Writing To	114
Interrupt (INT, TMR0 Pins).....	40	External Clock Input.....	114
Master Mode Transmit Clock Arbitration.....	169	In Timer Mode	115
Oscillator Start-up Time	24	One Capture and One Period Register Mode.....	110
PIC17C752/756 Capture Timing.....	253	Overview	95
PIC17C752/756 CLKOUT and I/O	250	Reading/Writing	114
PIC17C752/756 External Clock	249	TMR3 Interrupt Flag bit, TMR3IF	37
PIC17C752/756 Memory Interface Read	266	TMR3CS	101, 110
PIC17C752/756 Memory Interface Write	265	TMR3H	28, 49
PIC17C752/756 PWM Timing	253	TMR3IE.....	35
PIC17C752/756 Reset, Watchdog Timer, Oscillator		TMR3IF.....	37, 110
Start-up Timer and Power-up Timer	251	TMR3L	28, 49
PIC17C752/756 Timer0 Clock	252	TMR3ON.....	102, 110
PIC17C752/756 Timer1, Timer2 and Timer3 Clock ..	252	TO	52, 193, 194
PIC17C752/756 USART Module Synchronous		Transmit Status and Control Register.....	117
Receive	261	TSTFSZ	230
PIC17C752/756 USART Module		TTL INPUT.....	278
Synchronous Transmission.....	260	Turning on 16-bit Timer	105
Repeat START Condition	156	TX1IE	35
Slave Synchronization	140	TX1IF	37
STOP Condition Receive or Transmit.....	167	TX2IE.....	36
Synchronous Reception.....	129	TX2IF.....	38
Synchronous Transmission.....	128	TXREG	123, 127, 131, 132
Table Write.....	62	TXREG1	27, 48

TXREG2.....	27, 49
TXSTA	126, 130, 132
TXSTA Register	
TXEN Bit.....	34, 51, 97, 101, 117
TXSTA1	27, 48
TXSTA2	27, 49
U	
UA	134
Update Address, UA	134
Upward Compatibility	7
USART	
Asynchronous Master Transmission.....	123
Asynchronous Mode	123
Asynchronous Receive	125
Asynchronous Transmitter	123
Baud Rate Generator.....	120
Synchronous Master Mode.....	127
Synchronous Master Reception.....	129
Synchronous Master Transmission.....	127
Synchronous Slave Mode	131
Synchronous Slave Transmit.....	131
Transmit Enable (TXEN Bit).....	34, 51, 97, 101, 117
USART1 Receive Interrupt	37
USART1 Transmit Interrupt	37
USART2 Receive Interrupt Enable, RC2IE.....	36
USART2 Receive Interrupt Flag bit, RC2IF	38
USART2 Receive Interrupt Flag bit, TX2IF	38
USART2 Transmit Interrupt Enable, TX2IE	36
V	
VDD.....	242
VOH vs. IOH	276
VOL vs. IOL	276

W	
Wake-up from SLEEP.....	194
Wake-up from SLEEP Through Interrupt.....	194
Watchdog Timer	193
Waveform for General Call Address Sequence.....	149
Waveforms	
External Program Memory Access	45
WCOL	135, 154, 159, 162, 165, 167
WCOL Status Flag.....	154
WDT	193
Clearing the WDT	193
Normal Timer.....	193
Period	193
Programming Considerations	193
WDT PERIOD.....	275
WDTPS0.....	191
WDTPS1.....	191
Write Collision Detect bit, WCOL.....	135
WWW, On-Line Support	5
X	
XORLW	231
XORWF	231
Z	
Z	11, 51
Zero (Z).....	11

PIC17C7XX

NOTES:

ON-LINE SUPPORT

Microchip provides on-line support on the Microchip World Wide Web (WWW) site.

The web site is used by Microchip as a means to make files and information easily available to customers. To view the site, the user must have access to the Internet and a web browser, such as Netscape or Microsoft Explorer. Files are also available for FTP download from our FTP site.

Connecting to the Microchip Internet Web Site

The Microchip web site is available by using your favorite Internet browser to attach to:

www.microchip.com

The file transfer site is available by using an FTP service to connect to:

<ftp://ftp.microchip.com>

The web site and file transfer site provide a variety of services. Users may download files for the latest Development Tools, Data Sheets, Application Notes, User's Guides, Articles and Sample Programs. A variety of Microchip specific business information is also available, including listings of Microchip sales offices, distributors and factory representatives. Other data available for consideration is:

- Latest Microchip Press Releases
- Technical Support Section with Frequently Asked Questions
- Design Tips
- Device Errata
- Job Postings
- Microchip Consultant Program Member Listing
- Links to other useful web sites related to Microchip Products
- Conferences for products, Development Systems, technical information and more
- Listing of seminars and events

PIC17C7XX

READER RESPONSE

It is our intention to provide you with the best documentation possible to ensure successful use of your Microchip product. If you wish to provide your comments on organization, clarity, subject matter, and ways in which our documentation can better serve you, please FAX your comments to the Technical Publications Manager at (480) 792-4150.

Please list the following information, and use this outline to provide us with your comments about this Data Sheet.

To: Technical Publications Manager Total Pages Sent
RE: Reader Response
From: Name _____
Company _____
Address _____
City / State / ZIP / Country _____
Telephone: (_____) _____ - _____ FAX: (_____) _____ - _____

Application (optional):

Would you like a reply? ___Y ___N

Device: **PIC17C7XX** Literature Number: **DS30289C**

Questions:

1. What are the best features of this document?

2. How does this document meet your hardware and software development needs?

3. Do you find the organization of this data sheet easy to follow? If not, why?

4. What additions to the data sheet do you think would enhance the structure and subject?

5. What deletions from the data sheet could be made without affecting the overall usefulness?

6. Is there any incorrect or misleading information (what and where)?

7. How would you improve this document?

8. How would you improve our software, systems, and silicon products?

PRODUCT IDENTIFICATION SYSTEM

To order or obtain information, e.g., on pricing or delivery, refer to the factory or the listed sales office.

PART NO.	X	/XX	XXX
Device	Temperature Range	Package	Pattern
Device	PIC17C756: Standard VDD range PIC17C756T: (Tape and Reel) PIC17LC756: Extended VDD range		
Temperature Range	- = 0°C to +70°C I = -40°C to +85°C		
Package	CL = Windowed LCC PT = TQFP L = PLCC		
Pattern	QTP, SQTP, ROM Code (factory specified) or Special Requirements . Blank for OTP and Windowed devices.		

Examples:

a) PIC17C756 – 16L Commercial Temp., PLCC package, 16 MHz, normal VDD limits

b) PIC17LC756–08/PT Commercial Temp., TQFP package, 8MHz, extended VDD limits

c) PIC17C756–33I/PT Industrial Temp., TQFP package, 33 MHz, normal VDD limits

* JW Devices are UV erasable and can be programmed to any device configuration. JW Devices meet the electrical requirement of each oscillator type.

Sales and Support

Data Sheets

Products supported by a preliminary Data Sheet may have an errata sheet describing minor operational differences and recommended workarounds. To determine if an errata sheet exists for a particular device, please contact one of the following:

1. Your local Microchip sales office
2. The Microchip Corporate Literature Center U.S. FAX: (480) 792-7277
3. The Microchip Worldwide Site (www.microchip.com)

Please specify which device, revision of silicon and Data Sheet (include Literature #) you are using.

New Customer Notification System

Register on our web site (www.microchip.com/cn) to receive the most current information on our products.

PIC17C7XX

NOTES:

NOTES:

PIC17C7XX

Note the following details of the code protection feature on Microchip devices:

- Microchip products meet the specification contained in their particular Microchip Data Sheet.
- Microchip believes that its family of products is one of the most secure families of its kind on the market today, when used in the intended manner and under normal conditions.
- There are dishonest and possibly illegal methods used to breach the code protection feature. All of these methods, to our knowledge, require using the Microchip products in a manner outside the operating specifications contained in Microchip's Data Sheets. Most likely, the person doing so is engaged in theft of intellectual property.
- Microchip is willing to work with the customer who is concerned about the integrity of their code.
- Neither Microchip nor any other semiconductor manufacturer can guarantee the security of their code. Code protection does not mean that we are guaranteeing the product as “unbreakable.”

Code protection is constantly evolving. We at Microchip are committed to continuously improving the code protection features of our products. Attempts to break Microchip's code protection feature may be a violation of the Digital Millennium Copyright Act. If such acts allow unauthorized access to your software or other copyrighted work, you may have a right to sue for relief under that Act.

Information contained in this publication regarding device applications and the like is provided only for your convenience and may be superseded by updates. It is your responsibility to ensure that your application meets with your specifications. MICROCHIP MAKES NO REPRESENTATIONS OR WARRANTIES OF ANY KIND WHETHER EXPRESS OR IMPLIED, WRITTEN OR ORAL, STATUTORY OR OTHERWISE, RELATED TO THE INFORMATION, INCLUDING BUT NOT LIMITED TO ITS CONDITION, QUALITY, PERFORMANCE, MERCHANTABILITY OR FITNESS FOR PURPOSE. Microchip disclaims all liability arising from this information and its use. Use of Microchip devices in life support and/or safety applications is entirely at the buyer's risk, and the buyer agrees to defend, indemnify and hold harmless Microchip from any and all damages, claims, suits, or expenses resulting from such use. No licenses are conveyed, implicitly or otherwise, under any Microchip intellectual property rights.

Trademarks

The Microchip name and logo, the Microchip logo, dsPIC, FlashFlex, KEELOQ, KEELOQ logo, MPLAB, PIC, PICmicro, PICSTART, PIC³² logo, rPIC, SST, SST Logo, SuperFlash and UNI/O are registered trademarks of Microchip Technology Incorporated in the U.S.A. and other countries.

FilterLab, Hampshire, HI-TECH C, Linear Active Thermistor, MTP, SEEVAL and The Embedded Control Solutions Company are registered trademarks of Microchip Technology Incorporated in the U.S.A.

Silicon Storage Technology is a registered trademark of Microchip Technology Inc. in other countries.

Analog-for-the-Digital Age, Application Maestro, BodyCom, chipKIT, chipKIT logo, CodeGuard, dsPICDEM, dsPICDEM.net, dsPICworks, dsSPEAK, ECAN, ECONOMONITOR, FanSense, HI-TIDE, In-Circuit Serial Programming, ICSP, Mindi, MiWi, MPASM, MPF, MPLAB Certified logo, MPLIB, MPLINK, mTouch, Omniclient Code Generation, PICC, PICC-18, PICDEM, PICDEM.net, PICkit, PICtail, REAL ICE, rLAB, Select Mode, SQI, Serial Quad I/O, Total Endurance, TSHARC, UniWinDriver, WiperLock, ZENA and Z-Scale are trademarks of Microchip Technology Incorporated in the U.S.A. and other countries.

SQTP is a service mark of Microchip Technology Incorporated in the U.S.A.

GestIC and ULPP are registered trademarks of Microchip Technology Germany II GmbH & Co. & KG, a subsidiary of Microchip Technology Inc., in other countries.

All other trademarks mentioned herein are property of their respective companies.

© 1998-2013, Microchip Technology Incorporated, Printed in the U.S.A., All Rights Reserved.

 Printed on recycled paper.

ISBN: 9781620769317

Microchip received ISO/TS-16949:2009 certification for its worldwide headquarters, design and wafer fabrication facilities in Chandler and Tempe, Arizona; Gresham, Oregon and design centers in California and India. The Company's quality system processes and procedures are for its PIC[®] MCUs and dsPIC[®] DSCs, KEELOQ[®] code hopping devices, Serial EEPROMs, microperipherals, nonvolatile memory and analog products. In addition, Microchip's quality system for the design and manufacture of development systems is ISO 9001:2000 certified.

QUALITY MANAGEMENT SYSTEM
CERTIFIED BY DNV
== ISO/TS 16949 ==



MICROCHIP

Worldwide Sales and Service

AMERICAS

Corporate Office
2355 West Chandler Blvd.
Chandler, AZ 85224-6199
Tel: 480-792-7200
Fax: 480-792-7277
Technical Support:
<http://www.microchip.com/support>
Web Address:
www.microchip.com

Atlanta
Duluth, GA
Tel: 678-957-9614
Fax: 678-957-1455

Boston
Westborough, MA
Tel: 774-760-0087
Fax: 774-760-0088

Chicago
Itasca, IL
Tel: 630-285-0071
Fax: 630-285-0075

Cleveland
Independence, OH
Tel: 216-447-0464
Fax: 216-447-0643

Dallas
Addison, TX
Tel: 972-818-7423
Fax: 972-818-2924

Detroit
Farmington Hills, MI
Tel: 248-538-2250
Fax: 248-538-2260

Indianapolis
Noblesville, IN
Tel: 317-773-8323
Fax: 317-773-5453

Los Angeles
Mission Viejo, CA
Tel: 949-462-9523
Fax: 949-462-9608

Santa Clara
Santa Clara, CA
Tel: 408-961-6444
Fax: 408-961-6445

Toronto
Mississauga, Ontario,
Canada
Tel: 905-673-0699
Fax: 905-673-6509

ASIA/PACIFIC

Asia Pacific Office
Suites 3707-14, 37th Floor
Tower 6, The Gateway
Harbour City, Kowloon
Hong Kong
Tel: 852-2401-1200
Fax: 852-2401-3431

Australia - Sydney
Tel: 61-2-9868-6733
Fax: 61-2-9868-6755

China - Beijing
Tel: 86-10-8569-7000
Fax: 86-10-8528-2104

China - Chengdu
Tel: 86-28-8665-5511
Fax: 86-28-8665-7889

China - Chongqing
Tel: 86-23-8980-9588
Fax: 86-23-8980-9500

China - Hangzhou
Tel: 86-571-2819-3187
Fax: 86-571-2819-3189

China - Hong Kong SAR
Tel: 852-2943-5100
Fax: 852-2401-3431

China - Nanjing
Tel: 86-25-8473-2460
Fax: 86-25-8473-2470

China - Qingdao
Tel: 86-532-8502-7355
Fax: 86-532-8502-7205

China - Shanghai
Tel: 86-21-5407-5533
Fax: 86-21-5407-5066

China - Shenyang
Tel: 86-24-2334-2829
Fax: 86-24-2334-2393

China - Shenzhen
Tel: 86-755-8864-2200
Fax: 86-755-8203-1760

China - Wuhan
Tel: 86-27-5980-5300
Fax: 86-27-5980-5118

China - Xian
Tel: 86-29-8833-7252
Fax: 86-29-8833-7256

China - Xiamen
Tel: 86-592-2388138
Fax: 86-592-2388130

China - Zhuhai
Tel: 86-756-3210040
Fax: 86-756-3210049

ASIA/PACIFIC

India - Bangalore
Tel: 91-80-3090-4444
Fax: 91-80-3090-4123

India - New Delhi
Tel: 91-11-4160-8631
Fax: 91-11-4160-8632

India - Pune
Tel: 91-20-2566-1512
Fax: 91-20-2566-1513

Japan - Osaka
Tel: 81-6-6152-7160
Fax: 81-6-6152-9310

Japan - Tokyo
Tel: 81-3-6880-3770
Fax: 81-3-6880-3771

Korea - Daegu
Tel: 82-53-744-4301
Fax: 82-53-744-4302

Korea - Seoul
Tel: 82-2-554-7200
Fax: 82-2-558-5932 or
82-2-558-5934

Malaysia - Kuala Lumpur
Tel: 60-3-6201-9857
Fax: 60-3-6201-9859

Malaysia - Penang
Tel: 60-4-227-8870
Fax: 60-4-227-4068

Philippines - Manila
Tel: 63-2-634-9065
Fax: 63-2-634-9069

Singapore
Tel: 65-6334-8870
Fax: 65-6334-8850

Taiwan - Hsin Chu
Tel: 886-3-5778-366
Fax: 886-3-5770-955

Taiwan - Kaohsiung
Tel: 886-7-213-7828
Fax: 886-7-330-9305

Taiwan - Taipei
Tel: 886-2-2508-8600
Fax: 886-2-2508-0102

Thailand - Bangkok
Tel: 66-2-694-1351
Fax: 66-2-694-1350

EUROPE

Austria - Wels
Tel: 43-7242-2244-39
Fax: 43-7242-2244-393

Denmark - Copenhagen
Tel: 45-4450-2828
Fax: 45-4485-2829

France - Paris
Tel: 33-1-69-53-63-20
Fax: 33-1-69-30-90-79

Germany - Munich
Tel: 49-89-627-144-0
Fax: 49-89-627-144-44

Italy - Milan
Tel: 39-0331-742611
Fax: 39-0331-466781

Netherlands - Drunen
Tel: 31-416-690399
Fax: 31-416-690340

Spain - Madrid
Tel: 34-91-708-08-90
Fax: 34-91-708-08-91

UK - Wokingham
Tel: 44-118-921-5869
Fax: 44-118-921-5820

11/29/12

Looking for pricing, stock, or lifecycle information?

Click below to explore more details on WIN SOURCE:

- ⊖ [View PIC17C756A-33I/PT on WIN SOURCE](#)
- ⊖ [Microchip Technology](#) Information

Optimize Your Supply Chain with WIN SOURCE Solutions

- ✓ Global Sourcing Solution
- ✓ Obsolete Management
- ✓ Cost Control Management
- ✓ Shortage Management
- ✓ Alternative Solution
- ✓ Excess Inventory Management