



**THE DATASHEET OF
AP3102M-G1**



Description

The AP3102/V/L series is a green-mode PWM controller with low start-up current. At normal operation, the switching frequency is externally programmable and trimmed to tight range, and the frequency dithering technique is also equipped to improve the EMI performance. When the load is very low or zero, the IC enters green mode and skip mode to minimize switching loss. In skip mode, the PWM switching frequency is about 20kHz to avoid the audible noise and reduce the standby loss.

The AP3102/V/L series features a lot of functions such as the Leading-Edge Blanking (LEB) of the current sensing, internal slope compensation, line compensation, and several protection functions including cycle-by-cycle current limit (OCP), over voltage protection (VCC or line voltage), OTP, OLP and brownout protection.

The AP3102/V/L series provides 3 different versions with optional protection functions. AP3102 has external trigger latch shutdown only (VOVP and OLP are auto recoverable). AP3102V supports both VOVP and external latch shutdown. AP3102L provides latch shutdown control for VOVP, OLP and external trigger.

This IC is available in SO-8 package.

Features

- Bi-CMOS Process with Excellent Performance
- Very Low Start-up Current: 5µA Typical
- Current Mode Control
- Non-audible-noise Green Mode Control
- Frequency Foldback for High Average Efficiency
- Internal Slope Compensation
- Programmable Brownout Protection
- Programmable Line Compensation
- Useful Pin Fault Protection:
 - SENSE Pin Floating
 - RI Pin Short to Ground
 - RI Pin Floating
- Smart Latch/Auto-recoverable Protection Option
- Comprehensive Protection Feature:
 - VCC Over Voltage Protection (VOVP)
 - Line Over Voltage Protection (LOVP)
 - Over Temperature Protection (OTP)
 - Over Load Protection (OLP)
- Internal Soft Start Function During Start-up
- 500mA Gate Output Current Capability
- **Totally Lead-free & Fully RoHS Compliant (Notes 1 & 2)**
- **Halogen and Antimony Free. "Green" Device (Note 3)**

Notes: 1. No purposely added lead. Fully EU Directive 2002/95/EC (RoHS) & 2011/65/EU (RoHS 2) compliant.
 2. See http://www.diodes.com/quality/lead_free.html for more information about Diodes Incorporated's definitions of Halogen- and Antimony-free, "Green" and Lead-free.
 3. Halogen- and Antimony-free "Green" products are defined as those which contain <900ppm bromine, <900ppm chlorine (<1500ppm total Br + Cl) and <1000ppm antimony compounds.

Pin Assignments

(Top View)

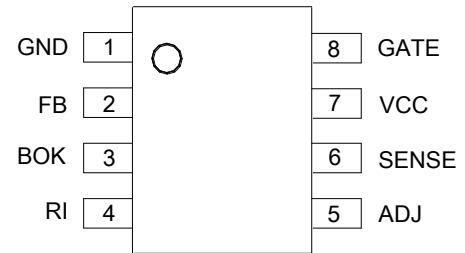

SO-8

Applications

- Switching AC-DC Adapter
- LCD Monitor/TV Power
- Open Frame Switching Power Supply

Typical Applications Circuit

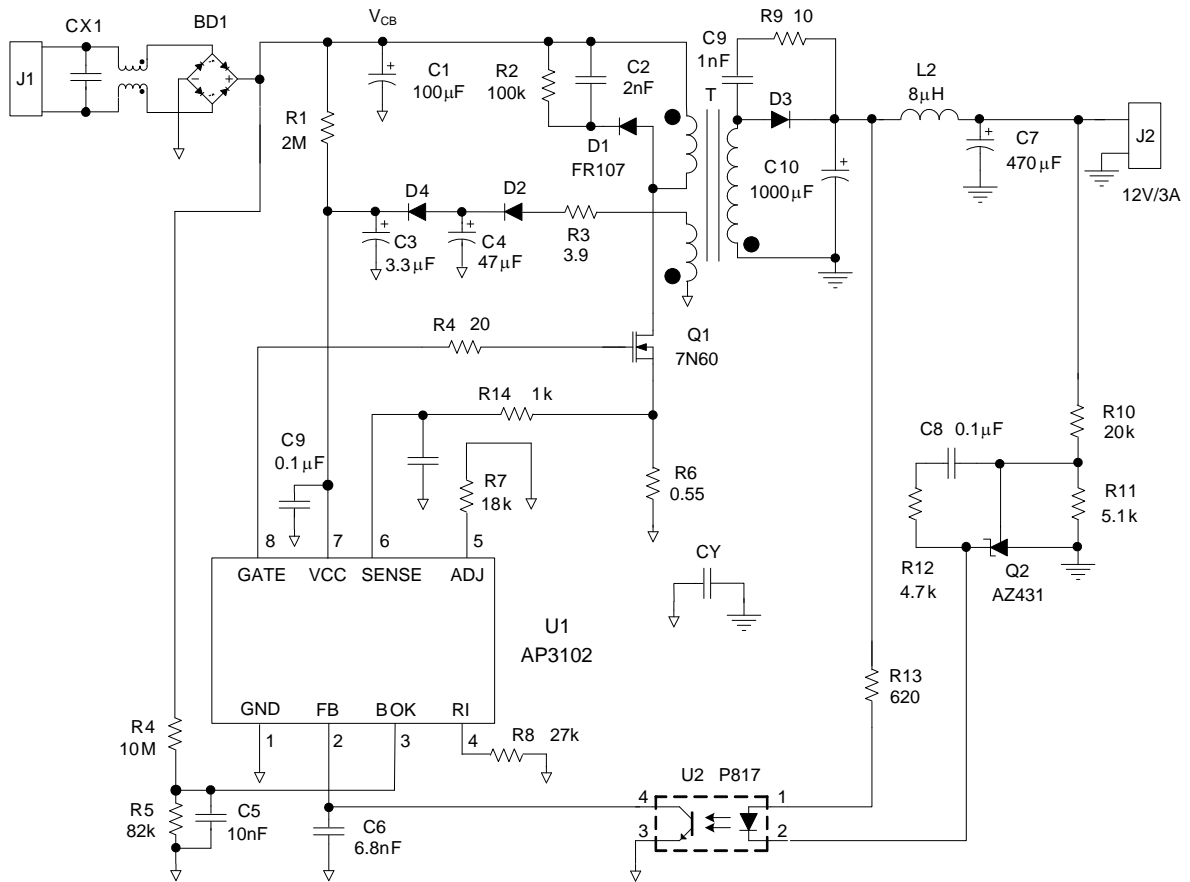

For AP3102

Pin Descriptions

Pin Number	Pin Name	Function
1	GND	Signal ground. Current return for driver and control circuits
2	FB	Feedback. Directly connected to the opto-coupler
3	BOK	Brownout Protection Pin. Connected to a resistor divider from the ground to bulk capacitor for setting the brownout level and line compensation. When the voltage of this pin is lower than 0.5V and lasts 35ms, the PWM signal will be off and system enters the auto recoverable protection mode (hiccup mode). Moreover, this pin is also applied for line OVP (trigger level is 4V) and line compensation (compensate the current sense for over load protection.)
4	RI	Set the bias current to determine the normal switching frequency
5	ADJ	To adjust the level of skip cycle. When its value is greater than 4.5V, the system will be latched
6	SENSE	Current sense
7	VCC	Supply voltage of driver and control circuits
8	GATE	Gate driver output

Functional Block Diagram

NEW PRODUCT

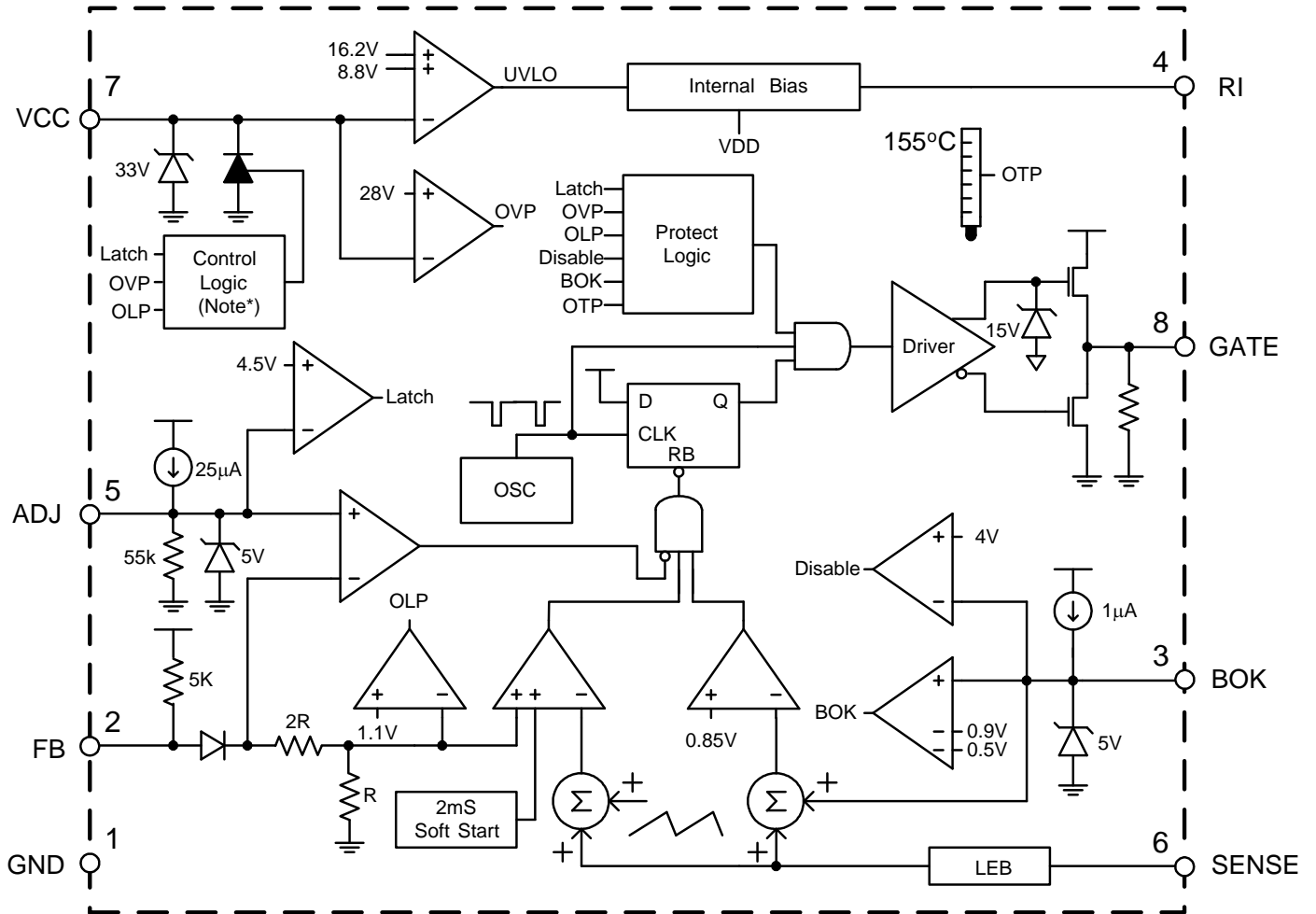

Note*

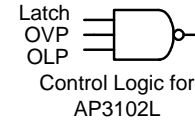
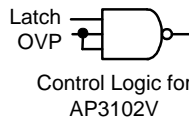
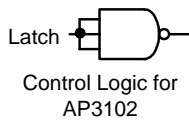

Absolute Maximum Ratings (Note 4)

Symbol	Parameter	Rating	Unit
V_{CC}	Power Supply Voltage	30	V
I_o	Gate Output Current	500	mA
V_{FB}, V_{SENSE}	Input Voltage to FB, SENSE pin	-0.3 to 7	V
V_{RI}, V_{ADJ}	Input Voltage to RI, ADJ pin	-0.3 to 7	V
θ_{JA}	Thermal Resistance (Junction to Ambient)	186	°C/W
P_D	Power Dissipation and Thermal Characteristic, SENSE at $T_A < +25^\circ\text{C}$	550	mW
T_J	Operation Junction Temperature	-40 to +150	°C
T_{STG}	Storage Temperature Range	+150	°C
–	ESD (Human Body Model)	2500	V
–	ESD (Machine Model)	250	V

Note 4: Stresses greater than those listed under "Absolute Maximum Ratings" may cause permanent damage to the device. These are stress ratings only, and functional operation of the device at these or any other conditions beyond those indicated under "Recommended Operating Conditions" is not implied. Exposure to "Absolute Maximum Ratings" for extended periods may affect device reliability.

Recommended Operating Conditions

Symbol	Parameter	Min	Max	Unit
V_{CC}	Supply Voltage	10	25	V
T_A	Ambient Operating Temperature Range	-40	+85	°C

Electrical Characteristics ($V_{CC}=16\text{V}$, $T_A=+25^\circ\text{C}$, unless otherwise specified.)

Symbol	Parameter	Conditions	Min	Typ	Max	Unit
Supply Voltage (VCC Pin)						
$I_{START-UP}$	Start-up Current	$V_{CC}=14.8\text{V}$	–	5	15	μA
I_{CC}	Operating Supply Current	$V_{FB}=0\text{V}$, $C_L=1\text{nF}$	1.5	2.5	3.5	mA
		$V_{FB}=3\text{V}$, $C_L=1\text{nF}$	2	3	4	
–	UVLO (on)	–	15.2	16.2	17.2	V
–	UVLO (off)	–	7.8	8.8	9.8	V
–	VCC OVP	–	27	28.5	30	V
–	VCC Clamp	$I_{CC}=5\text{mA}$	–	–	34	V
–	De-Latch VCC	–	4.5	6	7.5	V
PWM Section/Oscillator Section						
–	Maximum Duty Cycle	–	70	75	80	%
–	Minimum Duty Cycle	–	–	0	–	
–	Oscillation Frequency	$R_{RI}=26\text{k}\Omega$	60	65	70	kHz
–	Frequency in Skip Mode	$R_{RI}=26\text{k}\Omega$	22	–	–	kHz
–	Frequency Temperature Stability	-40°C to $+85^\circ\text{C}$	–	–	5	%
–	Frequency Voltage Stability	$V_{CC}=12\text{V}$ to 30V	–	–	3	%
–	Frequency Dithering	–	–	± 6	–	%

Electrical Characteristics ($V_{CC}=16V$, $T_A=+25^{\circ}C$, unless otherwise specified.) (Cont.)

Symbol	Parameter	Conditions	Min	Typ	Max	Unit
Current Sense Section (SENSE Pin)						
V_{CS}	Maximum SENSE Voltage	$V_{BOK}=0.95V$	0.75	0.8	0.85	V
		$V_{BOK}=2.76V$	0.63	0.68	0.73	
-	LEB Time of SENSE	$R_{RI}=26k\Omega$	150	250	350	ns
-	Delay to Output	-	50	150	250	ns
-	Soft-start Time	$R_{RI}=26k\Omega$	-	2	-	ms
Feedback Input Section (FB Pin)						
-	The Ratio of Input Voltage to Current Sense Voltage	-	2.5	3	3.5	V/V
-	Input Impedance	-	3	4.5	6	$k\Omega$
-	Source Current	-	-	-	-2	mA
-	Input Voltage for Zero Duty	$V_{ADJ}=0V$	-	-	1.2	V
Output Section (GATE Pin)						
-	Output Low Level	$I_O=50mA$, $V_{CC}=12V$	-	-	1	V
-	Output High Level	$I_O=50mA$, $V_{CC}=12V$	8.5	-	-	V
-	Output Clamping	-	13	15	17	V
-	Rising Time	$C_L=1nF$, $V_{CC}=13V$	150	250	350	ns
-	Falling Time	$C_L=1nF$, $V_{CC}=13V$	30	50	90	ns
Brownout Protection (BOK Pin)						
-	Brownout Turn-on	-	0.85	0.9	0.95	V
-	Brownout Turn-off	-	0.45	0.5	0.55	
-	Clamp Voltage on BOK	$I_{BOK}=1mA$	5.5	6.2	6.9	V
-	Line Compensation Ratio	-	-	0.055	-	-
-	Line OVP Voltage	-	3.5	4	4.5	V
Skip Cycle Section (ADJ Pin)						
-	Source Current	-	10	25	45	μA
-	Latch Trigger Voltage	-	4.2	4.5	4.8	V
-	Clamp Voltage on ADJ	-	4	5	6	V
-	Input Impedance	-	35	50	65	$k\Omega$
Over-Temperature Protection Section						
-	Shutdown Temperature	-	-	+155	-	$^{\circ}C$
-	Temperature Hysteresis	-	-	+25	-	$^{\circ}C$
Delay Time Section						
-	Delay 1 of Protection	$R_{RI}=26k\Omega$, Output short and OLP BOK pin trigger for turning off	25	35	45	ms
-	Delay 2 of Protection	$R_{RI}=26k\Omega$, ADJ, VCC OVP, Line OVP BOK pin trigger for turning on	-	25	-	μs

Performance Characteristics

Start-up Voltage vs. Ambient Temperature

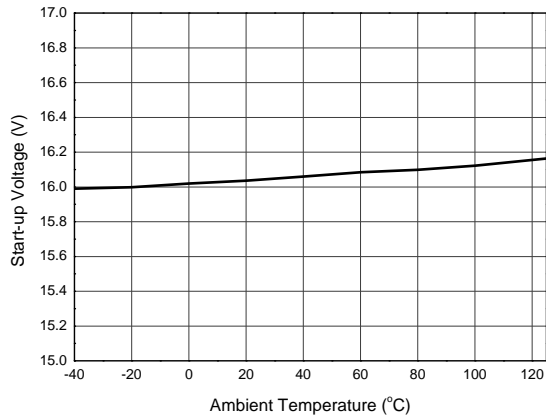

Shutdown Voltage vs. Ambient Temperature

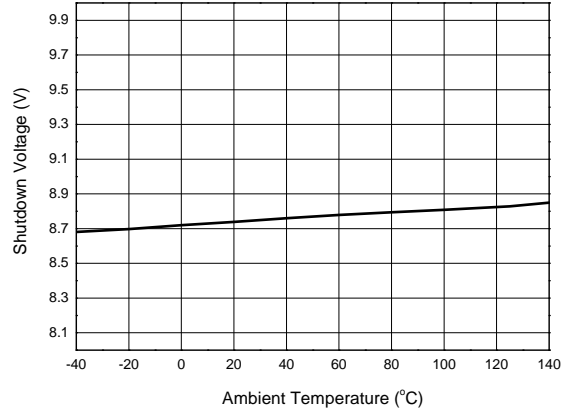

Start-up Current vs. Ambient Temperature

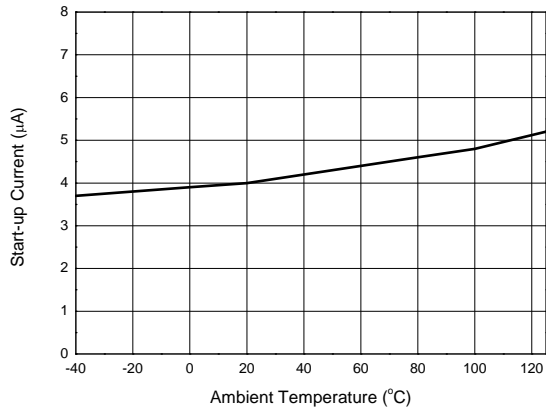

Operation Current vs. Ambient Temperature

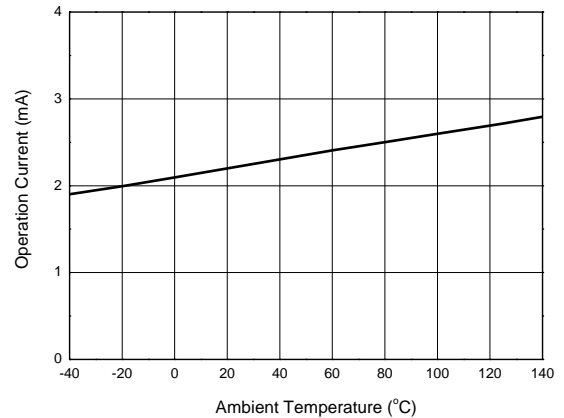

Maximum V_{CS} vs. Ambient Temperature

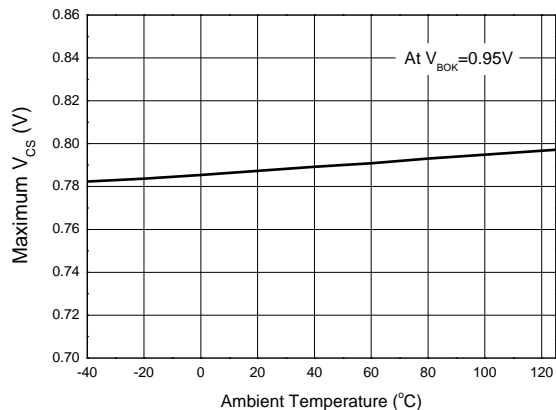

V_{BOK} vs. Ambient Temperature

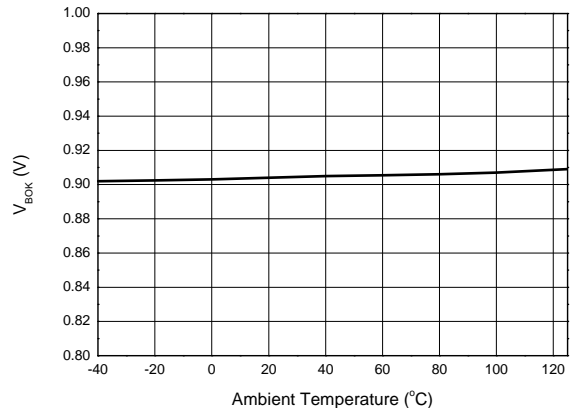

Performance Characteristics (Cont.)

VCC OVP Voltage vs. Ambient Temperature

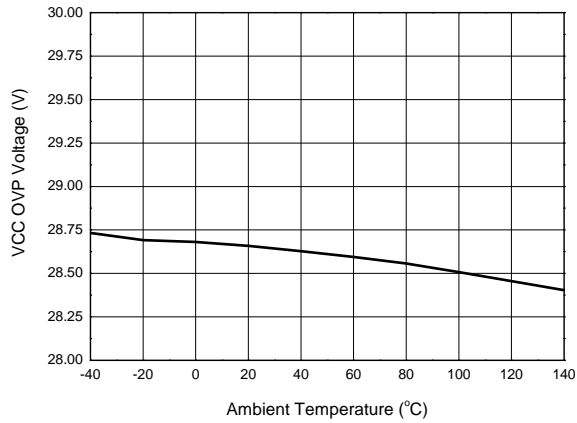

Oscillation Frequency vs. Bias Resistor

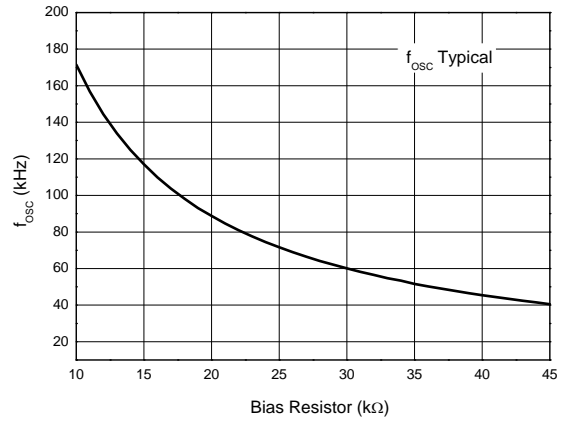

**Oscillation Frequency vs. Ambient Temperature
(R8=27kΩ)**

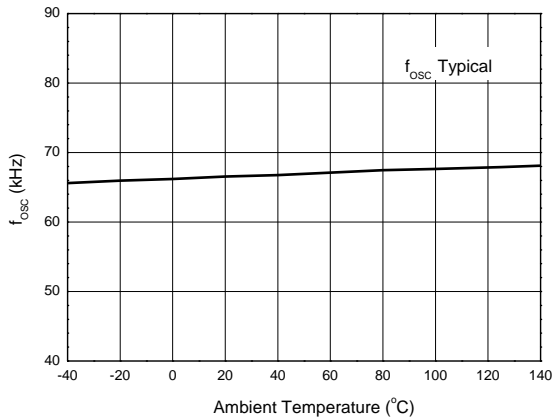

VCC Start-up Current vs. VCC Voltage

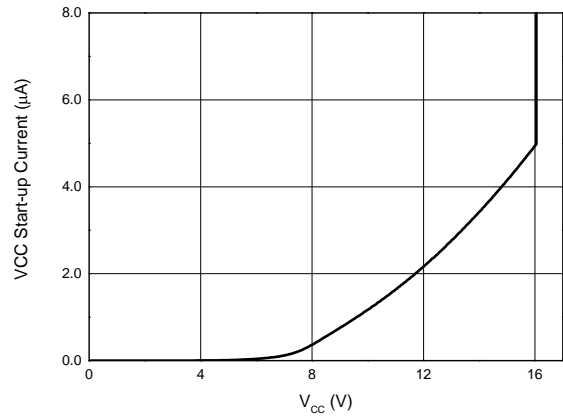

Operation Current vs. VCC Voltage

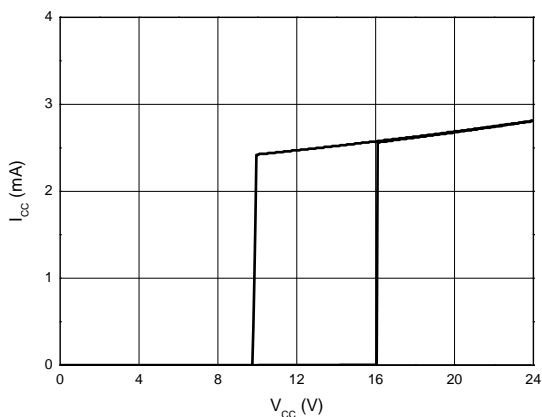

NEW PRODUCT

Operation Description

The AP3102V/L is specifically designed for off-line AC-DC power supply used in LCD monitor, notebook adapter and battery charger applications. It offers a cost effective solution with versatile protection functions for system designer.

Start-up Current and UVLO

The start-up current of AP3102V/L is optimized to realize ultra low current (5 μ A typical) so that VCC capacitor can be charged more quickly. The direct benefit of low start-up current is the availability of using large start-up resistor, which minimizes the resistor power loss for high voltage AC input.

A UVLO comparator is included in AP3102V/L to detect the voltage on the VCC pin. It ensures AP3102V/L to draw adequate energy from hold-up capacitor during power-on. The turn-on threshold is 16V and the turn-off threshold is 10V.

Oscillator

The oscillation frequency is programmed by the value of resistor R8, connected from pin RI to ground. The resistor will make a constant current source to determine the oscillation frequency by charging and discharging an internal capacitor.

The oscillation frequency can be expressed as:

$$f \approx \frac{1720}{R8(k\Omega)} (kHz)$$

The recommended oscillation frequency is 40 to 130kHz from the EMI consideration.

Current Sense Comparator and PWM Latch

AP3102V/L operates as a current mode controller; the output switch conduction is initiated by every oscillator cycle and terminated when the peak inductor current reaches the threshold level established by the FB pin. The inductor current signal is converted to a voltage signal by inserting a reference sense resistor R_S . The inductor current under normal operating conditions is controlled by the voltage at FB pin, the relation between peak inductor current (I_{PK}) and V_{FB} is:

$$I_{PK} = (V_{FB} - 0.9) / 3R_S$$

Abnormal operating conditions occur when the power supply output is overloaded or the output voltage sensing is lost. Under these conditions, the current sense comparator threshold will be internally clamped to a value related to the value of V_{BOK} . As V_{BOK} value is proportional to the input line voltage, the constant over load protection can be achieved by compensating the delay time effect from the input line. The maximum peak switch current is:

$$I_{PK(MAX)} = (0.85 - 0.055 \times V_{BOK}) / R_S$$

Leading-edge Blanking

A narrow spike on the leading edge of the current waveform can usually be observed when the power MOSFET is turned on. A 250ns leading-edge blank is built-in to prevent the false-triggering caused by the turn-on spike. During this period, the current limit comparator is disabled and the gate driver can not be switched off. A resistor is usually connected to the current sense pin to avoid the PCB trace interference and it also can adjust the inductor peak current tinely by the resistance. Of course, adding a RC filter to CS pin is better to attenuate any unexpected noise.

Built-in Slope Compensation

It is well known that a continuous current mode SMPS may become unstable when the duty cycle exceeds 50%. The built-in slope compensation can improve the stability, so there is no need for design engineer to spend much time on that.

FB Pin and Short Circuit Protection

This pin is normally connected to the opto-coupler and always paralleled with a capacitor for loop compensation. When the voltage at this pin is greater than 4.2V (such as output short to ground or the opto-coupler is broken) and lasts for about 35ms, the IC will enter the protection mode. For AP3102, the system will enter hiccup mode to wait the VCC decreasing to low UVLO level, then the IC will try to restart until the failure removes. For AP3102V, the IC will be latched unless unplugging the AC socket. Moreover, if the voltage is less than 0.7V, the IC will stop the drive pulse immediately. Therefore, this feature can be used for short circuit protection, which makes the system immune from catastrophic failure.

Operation Description (Cont.)

Brown-out and BOK Pin

The switching converter normally has a suitable input range, thus it makes the switching component operate under the safe operation condition. Too low or too high input will bring large heat shock or voltage spike on the switching device. Brown-out and line OVP function will avoid the supply to be worked in the unwanted condition such as below minimum and over maximum line voltage. The internal BOK connection is shown as the figure below:

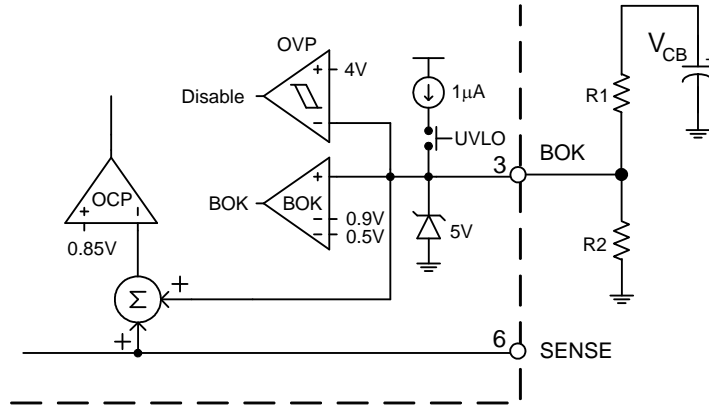

From the figure, it is seen that the BOK is connected to the OCP comparator and used as feedforward to the V_{CS_MAX} (Refer to current sense comparator description). The V_{BOK} range for enable IC is 0.9 to 3.0V and disable range is under 0.5V or over 4V. When V_{BOK} is over 4V (line OVP) or under 0.5V (brown-out trigger), the IC enters the auto-recoverable protection. The ratio of R1/R2 is used to adjust the line voltage divider value.

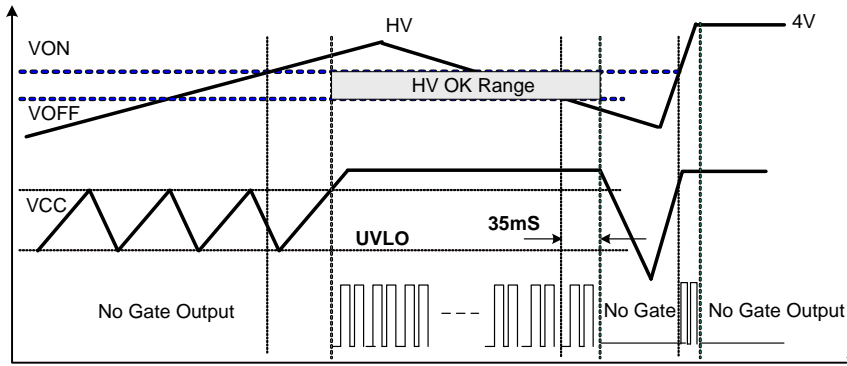

ADJ Pin and Green Mode Operation

Low standby loss is the main requirement for AC-DC off line power supply. The AP3102/V/L has a green mode operation to improve the light load or no load efficiency. When the load power becomes low and V_{FB} decreases to the threshold value, the IC will enter the green mode which means the switching frequency will decrease with the load decrease. And when the load power becomes much lower, the IC will operate at the skip mode to reduce switching loss, core loss and other high frequency loss due to blanking the driver. In skipping mode, the high frequency pulses is about 25kHz for the best standby performance.

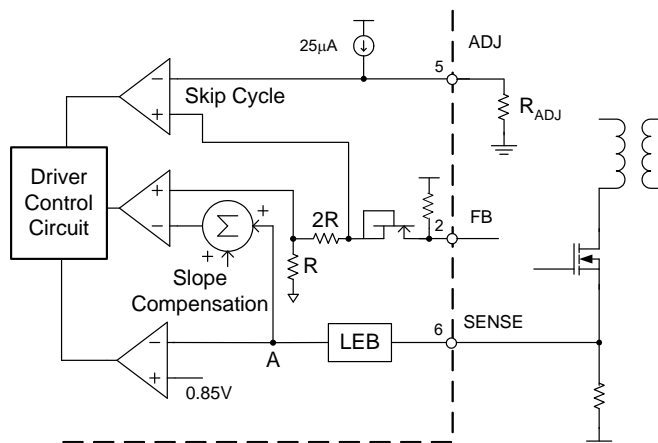

Operation Description (Cont.)

The V_{ADJ} threshold is adjustable by changing the external resistor connected from pin ADJ to the ground. Adjusting the V_{ADJ} voltage can optimize the standby power and audible noise for most applications.

Another function of ADJ pin is to use it as the latch trigger input. When the voltage at this pin is more than 4.5V, the system will be latched by limiting the V_{CC} to a lower voltage. If the IC is started from bulk capacitor through resistor, the system will be latched until the bulk voltage decreases to a very low value just like unplugged the AC input. Then, the IC latch current can't be maintained and latch will be released (see description below). This function can be used as system OTP and other protection.

System Protection and Pin Fault Protection

AP3102/V/L provides versatile system and pin fault protections. The OCP comparator realizes the cycle-by-cycle current limiting (OCP). Cooperating with BOK compensation from the input line voltage, the IC realizes the constant over load protection (OLP). VCC over voltage protection can be applied as the primary OVP or opto-coupler broken protection. The AP3102/V/L also has pin fault connection protection including floating and short connection. The floating pin protection includes the RI, SENSE, FB, etc; the short pin protection includes the RI pin short protection. When these pins are floated or RI pin is shorted to ground, PWM switching will be disabled, thus protect the power system. Below figures show the relative timing sequences of system protections.

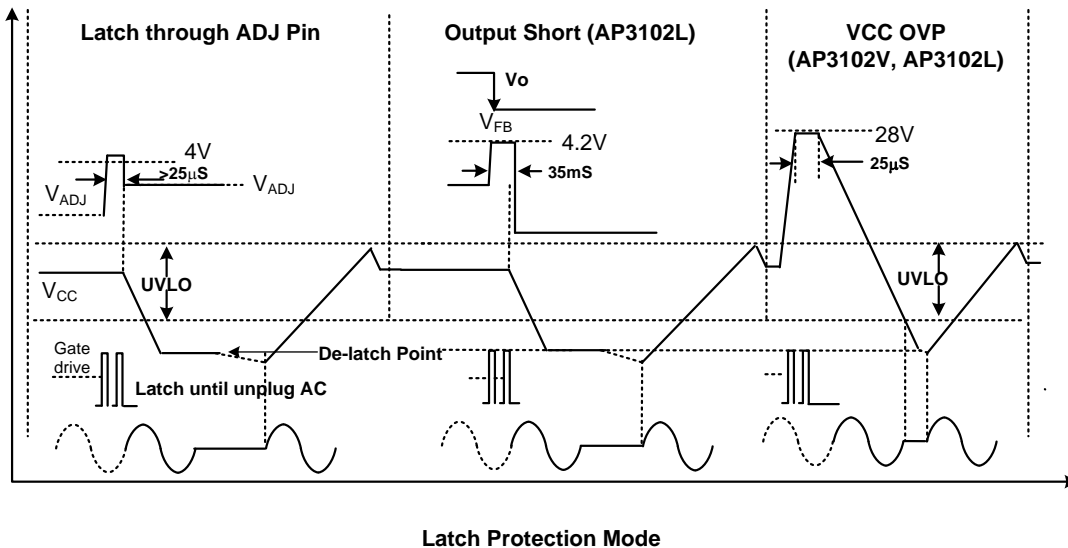
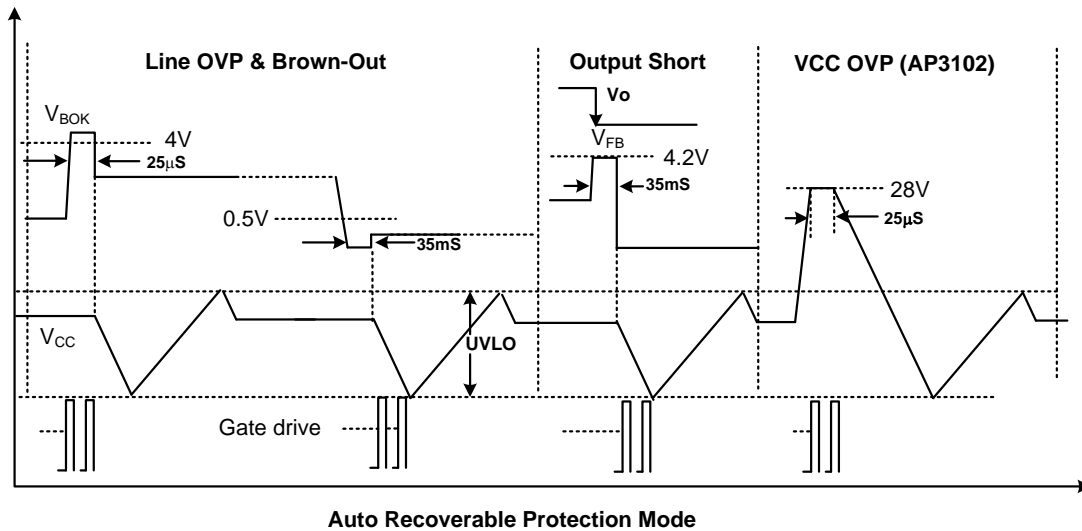

Typical Timing Sequences of AP3102/V/L Protections

NEW PRODUCT

Ordering Information

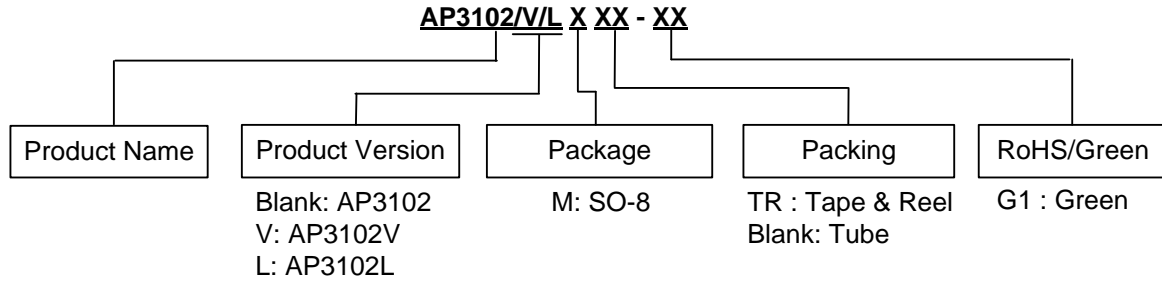

Diodes IC's Pb-free products with "G1" suffix in the part number, are RoHS compliant and green.

Package	Temperature Range	Part Number	Marking ID	Packing
SO-8	-40 to +85°C	AP3102M-G1	3102M-G1	100/Tube
		AP3102MTR-G1	3102M-G1	4000/Tape & Reel
		AP3102VM-G1	3102VM-G1	100/Tube
		AP3102VMTR-G1	3102VM-G1	4000/Tape & Reel
		AP3102LM-G1	3102LM-G1	100/Tube
		AP3102LMTR-G1	3102LM-G1	4000/Tape & Reel

Product Version Classification (with Different Protection Functions)

Product Version	External Trigger by ADJ	VOVP	Output Short (OLP)
AP3102	Latch	Auto-Recoverable	Auto-Recoverable
AP3102V	Latch	Latch	Auto-Recoverable
AP3102L	Latch	Latch	Latch

Marking Information

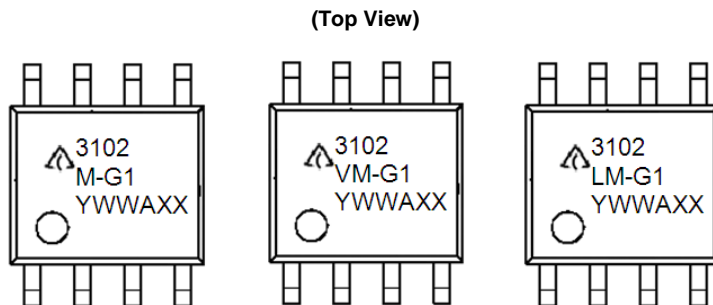

First and Second Lines: Logo and Marking ID
(See Ordering Information)
Third Line: Date Code
Y: Year
WW: Work Week of Molding
A: Assembly House Code
XX: 7th and 8th Digits of Batch No.

Package Outline Dimensions (All dimensions in mm(inch).)

(1) Package Type: SO-8

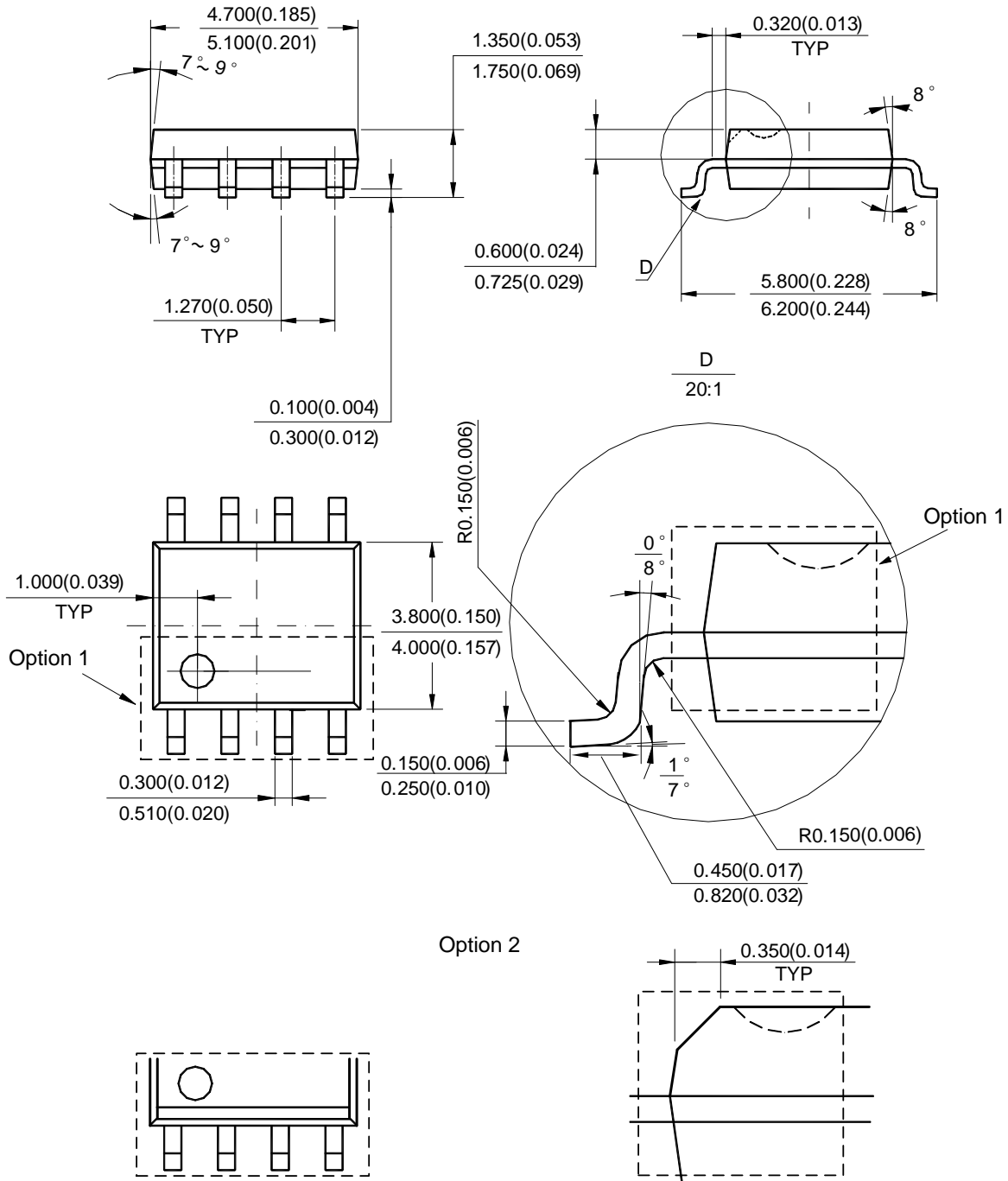

Note: Eject hole, oriented hole and mold mark is optional.

NEW PRODUCT

Suggested Pad Layout

(1) Package Type: SO-8

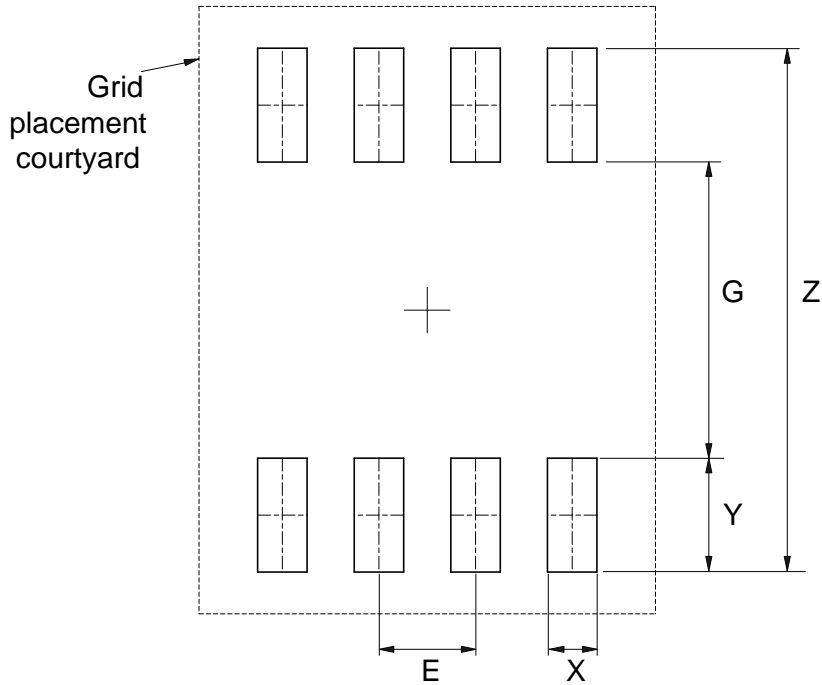

Dimensions	Z (mm)/(inch)	G (mm)/(inch)	X (mm)/(inch)	Y (mm)/(inch)	E (mm)/(inch)
Value	6.900/0.272	3.900/0.154	0.650/0.026	1.500/0.059	1.270/0.050

NEW PRODUCT

IMPORTANT NOTICE

DIODES INCORPORATED MAKES NO WARRANTY OF ANY KIND, EXPRESS OR IMPLIED, WITH REGARDS TO THIS DOCUMENT, INCLUDING, BUT NOT LIMITED TO, THE IMPLIED WARRANTIES OF MERCHANTABILITY AND FITNESS FOR A PARTICULAR PURPOSE (AND THEIR EQUIVALENTS UNDER THE LAWS OF ANY JURISDICTION).

Diodes Incorporated and its subsidiaries reserve the right to make modifications, enhancements, improvements, corrections or other changes without further notice to this document and any product described herein. Diodes Incorporated does not assume any liability arising out of the application or use of this document or any product described herein; neither does Diodes Incorporated convey any license under its patent or trademark rights, nor the rights of others. Any Customer or user of this document or products described herein in such applications shall assume all risks of such use and will agree to hold Diodes Incorporated and all the companies whose products are represented on Diodes Incorporated website, harmless against all damages.

Diodes Incorporated does not warrant or accept any liability whatsoever in respect of any products purchased through unauthorized sales channel. Should Customers purchase or use Diodes Incorporated products for any unintended or unauthorized application, Customers shall indemnify and hold Diodes Incorporated and its representatives harmless against all claims, damages, expenses, and attorney fees arising out of, directly or indirectly, any claim of personal injury or death associated with such unintended or unauthorized application.

Products described herein may be covered by one or more United States, international or foreign patents pending. Product names and markings noted herein may also be covered by one or more United States, international or foreign trademarks.

This document is written in English but may be translated into multiple languages for reference. Only the English version of this document is the final and determinative format released by Diodes Incorporated.

LIFE SUPPORT

Diodes Incorporated products are specifically not authorized for use as critical components in life support devices or systems without the express written approval of the Chief Executive Officer of Diodes Incorporated. As used herein:

A. Life support devices or systems are devices or systems which:

1. are intended to implant into the body, or
2. support or sustain life and whose failure to perform when properly used in accordance with instructions for use provided in the labeling can be reasonably expected to result in significant injury to the user.

B. A critical component is any component in a life support device or system whose failure to perform can be reasonably expected to cause the failure of the life support device or to affect its safety or effectiveness.

Customers represent that they have all necessary expertise in the safety and regulatory ramifications of their life support devices or systems, and acknowledge and agree that they are solely responsible for all legal, regulatory and safety-related requirements concerning their products and any use of Diodes Incorporated products in such safety-critical, life support devices or systems, notwithstanding any devices- or systems-related information or support that may be provided by Diodes Incorporated. Further, Customers must fully indemnify Diodes Incorporated and its representatives against any damages arising out of the use of Diodes Incorporated products in such safety-critical, life support devices or systems.

Copyright © 2014, Diodes Incorporated

www.diodes.com

Looking for pricing, stock, or lifecycle information?

Click below to explore more details on WIN SOURCE:

- ⊖ [View AP3102M-G1 on WIN SOURCE](#)
- ⊖ [Diodes Incorporated Information](#)

Optimize Your Supply Chain with WIN SOURCE Solutions

- ✓ Global Sourcing Solution
- ✓ Obsolete Management
- ✓ Cost Control Management
- ✓ Shortage Management
- ✓ Alternative Solution
- ✓ Excess Inventory Management