



**THE DATASHEET OF
NB7L216MNG**



NB7L216

2.5 V / 3.3 V, 12Gb/s Multi Level Clock/Data Input to RSECL, High Gain Receiver/Buffer/Translator with Internal Termination

Description

The NB7L216 is a differential receiver/driver with high gain output targeted for high frequency applications. The device is functionally equivalent to the NBSG16 but with much higher gain output. This highly versatile device provides 35 dB of gain up to 7 GHz.

Inputs incorporate internal 50 Ω termination resistors and accept Negative ECL (NECL), Positive ECL (PECL), LVTTTL, LVCMOS, CML, or LVDS. Outputs are Reduced Swing ECL (RSECL), 400 mV.

The V_{BB} pin is an internally generated voltage supply available to this device only. V_{BB} is used as a reference voltage for single-ended NECL or PECL inputs. For all single-ended input conditions, the unused complementary differential input should be connected to V_{BB} as a switching reference voltage. V_{BB} may also rebias AC coupled inputs. When used, decouple V_{BB} via a 0.01 μ F capacitor and limit current sourcing or sinking to 0.5 mA. When not used, V_{BB} output should be left open.

Application notes, models and support documentation are available at www.onsemi.com.

Features

- High Gain of 35 dB from DC to 7 GHz Typical
- High IIP3: 0 dBm Typical
- 20 mV Minimum Input Voltage Swing
- Maximum Input Clock Frequency up to 8.5 GHz
- Maximum Input Data Rate up to 12 Gb/s Typical
- < 0.5 ps of RMS Clock Jitter
- < 9 ps of Data Dependent Jitter
- 120 ps Typical Propagation Delay
- 30 ps Typical Rise and Fall Times
- RSPECL Output with Operating Range:
 $V_{CC} = 2.375$ V to 3.465 V with $V_{EE} = 0$ V
- RSNECL Output with RSNECL or NECL Inputs with Operating Range: $V_{CC} = 0$ V with $V_{EE} = -2.375$ V to -3.465 V
- RSECL Output Level (400 mV Peak-to-Peak Output),
- 50 Ω Internal Input Termination Resistors (Temperature-Coefficient of < 6.38 m Ω /°C)
- V_{BB} – ECL Reference Voltage Output
- This Device is Pb-Free, Halogen Free and is RoHS Compliant



ON Semiconductor®

www.onsemi.com



QFN-16
MN SUFFIX
CASE 485G

MARKING DIAGRAM*

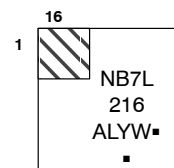

- A = Assembly Location
- L = Wafer Lot
- Y = Year
- W = Work Week
- = Pb-Free Package

(Note: Microdot may be in either location)

*For additional marking information, refer to Application Note [AND8002/D](#).

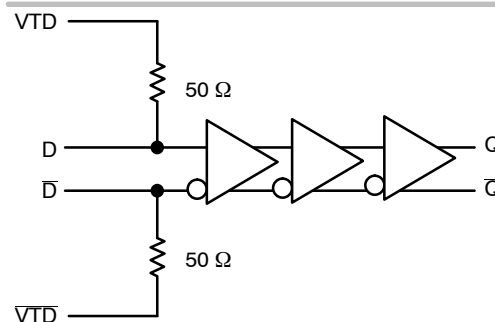

Figure 1. Functional Block Diagram

ORDERING INFORMATION

Device	Package	Shipping†
NB7L216MNG	QFN-16 (Pb-Free)	123 Units / Tube
NB7L216MNR2G	QFN-16 (Pb-Free)	3000 Tape & Reel

†For information on tape and reel specifications, including part orientation and tape sizes, please refer to our Tape and Reel Packaging Specifications Brochure, [BRD8011/D](#).

NB7L216

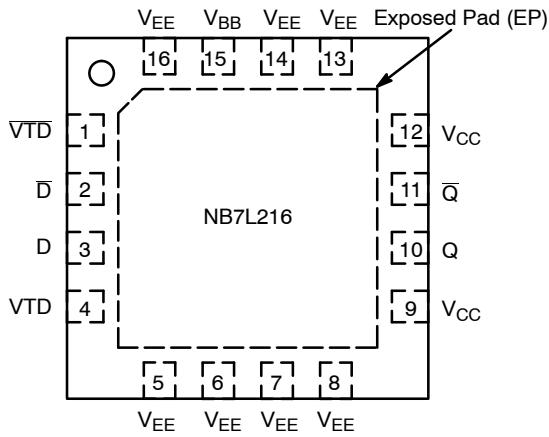

Figure 2. QFN-16 Pinout (Top View)

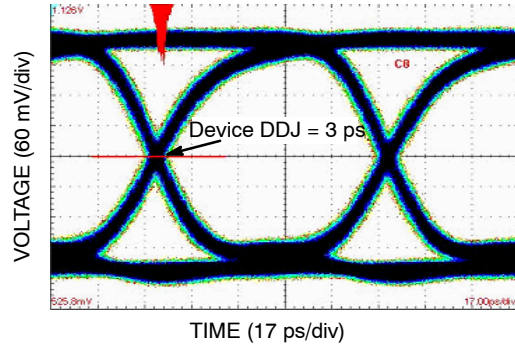

Figure 3. Typical Output Waveform at 12 Gb/s with PRBS $2^{23}-1$ ($V_{INPP} = 400$ mV, Input Signal DDJ = 12 ps)

Table 1. PIN DESCRIPTION

Pin	Name	I/O	Description
1	\overline{VTD}	-	Internal 50 Ω termination pin. See Table 7. Note 1
2	\overline{D}	LVPECL, CML, LVCMOS, LVDS, LVTTTL Input	Inverted differential input. Note 1.
3	D	LVPECL, CML, LVCMOS, LVDS, LVTTTL Input	Noninverted differential input. Note 1.
4	VTD	-	Internal 50 Ω termination pin. See Table 7. Note 1.
15	V_{BB}	-	Internally generated ECL reference voltage supply.
5, 6, 7, 8, 13, 14, 16	V_{EE}	-	Negative supply voltage. All V_{EE} pins must be externally connected to power supply to guarantee proper operation.
9, 12	V_{CC}	-	Positive supply voltage. All V_{CC} pins must be externally connected to power supply to guarantee proper operation
10	Q	RSECL Output	Noninverted differential output. Typically receiver terminated with 50 Ω resistor to $V_{TT} = V_{CC} - 2.0$ V.
11	\overline{Q}	RSECL Output	Inverted differential output. Typically receiver terminated with 50 Ω resistor to $V_{TT} = V_{CC} - 2.0$ V.
-	EP	-	Exposed pad (EP). Thermally exposed pad on the package bottom must be attached to a heat sinking conduit. It is recommended to connect the EP to the lower potential, V_{EE} .

1. In the differential configuration when the input termination pins (\overline{VTD} , VTD) are connected to a common termination voltage and if no signal is applied on D/ \overline{D} input then the device will be susceptible to self-oscillation.

NB7L216

Table 2. ATTRIBUTES

Characteristics	Value
ESD Protection Human Body Model Machine Model Charged Device Model	> 500 V > 10 V > 4 kV
Moisture Sensitivity (Note 2)	Pb-Free Pkg
QFN-16	Level 1
Flammability Rating Oxygen Index: 28 to 34	UL 94 V-0 @ 0.125 in
Transistor Count	164
Meets or exceeds JEDEC Spec EIA/JESD78 IC Latchup Test.	

1. For additional information, see Application Note [AND8003/D](#).

Table 3. MAXIMUM RATINGS (Note 1)

Symbol	Parameter	Condition 1	Condition 2	Rating	Unit
V_{CC}	Positive Power Supply	$V_{EE} = 0\text{ V}$		3.6	V
V_{EE}	Negative Power Supply	$V_{CC} = 0\text{ V}$		-3.6	V
V_I	Positive Input Negative Input	$V_{EE} = 0\text{ V}$ $V_{CC} = 0\text{ V}$	$V_I = V_{CC}$ $V_I = V_{EE}$	3.6 -3.6	V
V_{INPP}	Differential Input Voltage $ D - \bar{D} $			2.8	V
I_{IN}	Input Current Through R_T (50 Ω Resistor)	Static Surge		45 80	mA
I_{OUT}	Output Current	Continuous Surge		25 50	mA
I_{BB}	V_{BB} Sink/Source			± 0.5	mA
T_A	Operating Temperature Range			-40 to +85	$^{\circ}\text{C}$
T_{stg}	Storage Temperature Range			-65 to +150	$^{\circ}\text{C}$
θ_{JA}	Thermal Resistance (Junction-to-Ambient) (Note 2)	0 lfpm 500 lfpm	QFN-16 QFN-16	42 35	$^{\circ}\text{C}/\text{W}$
θ_{JC}	Thermal Resistance (Junction-to-Case)	1S2P (Note 4)	QFN-16	4	$^{\circ}\text{C}/\text{W}$
T_{sol}	Wave Solder (Pb-Free)			265	$^{\circ}\text{C}$

Stresses exceeding those listed in the Maximum Ratings table may damage the device. If any of these limits are exceeded, device functionality should not be assumed, damage may occur and reliability may be affected.

- Maximum ratings applied to the device are individual stress limit values (not normal operating conditions) and are not valid simultaneously. If stress limits are exceeded device functional operation is not implied, damage may occur and reliability may be affected.
- JEDEC standard multilayer board – 1S2P (1 signal, 2 power) with 8 filled thermal vias under exposed pad.

NB7L216

Table 4. DC CHARACTERISTICS, CLOCK INPUTS, RSECL OUTPUTS ($V_{CC} = 2.375\text{ V to }3.465\text{ V}$, $V_{EE} = 0\text{ V}$)

Symbol	Characteristic	-40 °C			25 °C			85 °C			Unit
		Min	Typ	Max	Min	Typ	Max	Min	Typ	Max	
I_{EE}	Power Supply Current (VTD/VTD open)		27	35		27	35		27	35	mA
V_{OH}	Output HIGH Voltage (Note 1 and 2)	$V_{CC} - 1040$	$V_{CC} - 980$	$V_{CC} - 940$	$V_{CC} - 1000$	$V_{CC} - 950$	$V_{CC} - 900$	$V_{CC} - 950$	$V_{CC} - 900$	$V_{CC} - 850$	mV
V_{OL}	Output LOW Voltage (Note 1 and 2)	$V_{CC} - 1520$	$V_{CC} - 1430$	$V_{CC} - 1320$	$V_{CC} - 1470$	$V_{CC} - 1370$	$V_{CC} - 1270$	$V_{CC} - 1440$	$V_{CC} - 1340$	$V_{CC} - 1240$	mV

DIFFERENTIAL INPUT DRIVEN SINGLE-ENDED (see Figures 14 and 16)

V_{TH}	Input Threshold Reference Voltage Range (Notes 3 and 5)	800		$V_{CC} - 10$	800		$V_{CC} - 10$	800		$V_{CC} - 10$	mV
V_{IH}	Single-ended Input HIGH Voltage	1105		V_{CC}	1105		V_{CC}	1105		V_{CC}	mV
V_{IL}	Single-ended Input LOW Voltage	V_{EE}		$V_{th} - 10$	V_{EE}		$V_{th} - 10$	V_{EE}		$V_{th} - 10$	mV
V_{ISE}	Single-Ended Input Voltage ($V_{IH} - V_{IL}$)	20		V_{CC}	20		V_{CC}	20		V_{CC}	mV

DIFFERENTIAL INPUTS DRIVEN DIFFERENTIALLY (see Figures 15 and 17)

V_{IHD}	Differential Input HIGH Voltage (Note 5)	1105		V_{CC}	1105		V_{CC}	1105		V_{CC}	mV
V_{ILD}	Differential Input LOW Voltage (Note 5)	V_{EE}		$V_{CC} - 10$	V_{EE}		$V_{CC} - 10$	V_{EE}		$V_{CC} - 10$	mV
V_{CMR}	Input Common Mode Range (Differential Configuration, Notes 5 and 6)	800		$V_{CC} - 5$	800		$V_{CC} - 5$	800		$V_{CC} - 5$	mV
V_{ID}	Differential Input Voltage ($V_{IHD} - V_{ILD}$)	10		2500	10		2500	10		2500	mV
V_{IO}	Input Offset Voltage (Note 4)	-5	0	+5	-5	0	+5	-5	0	+5	mV
V_{BB}	Internally Generated Reference Voltage Supply (Only 3 V – 3.6 V Supply Load with -100 μ A)	$V_{CC} - 1425$	$V_{CC} - 1345$	$V_{CC} - 1265$	$V_{CC} - 1425$	$V_{CC} - 1345$	$V_{CC} - 1265$	$V_{CC} - 1425$	$V_{CC} - 1345$	$V_{CC} - 1265$	mV
I_{IH}	Input HIGH Current D/Db (VTD/VTD Open)	0	20	100	0	20	100	0	20	100	μ A
I_{IL}	Input LOW Current D/Db (VTD/VTD Open)	-25	10	75	-25	10	75	-25	10	75	μ A
R_{TIN}	Internal Input Termination Resistor	45	50	55	45	50	55	45	50	55	Ω
R_{T_Coef}	Internal Input Termination Resistor Temperature Coefficient		6.38			6.38			6.38		m Ω /°C

NOTE: Device will meet the specifications after thermal equilibrium has been established when mounted in a test socket or printed circuit board with maintained airflow greater than 500 lfm. Electrical parameters are guaranteed only over the declared operating temperature range. Functional operation of the device exceeding these conditions is not implied. Device specification limit values are applied individually under normal operating conditions and not valid simultaneously.

1. Outputs evaluated with 50 Ω resistors to $V_{TT} = V_{CC} - 2.0\text{ V}$ for proper operation.
2. Input and output parameters vary 1:1 with V_{CC} .
3. V_{TH} is applied to the complementary input when operating in single-ended mode. $V_{th} = (V_{IH} - V_{IL}) / 2$.
4. Typical standard deviation of input offset voltage is 1.76 mV.
5. V_{th} , V_{IH} , V_{IL} , and V_{ISE} parameters must be complied with simultaneously.
6. V_{IHD} , V_{ILD} , V_{ID} and V_{CMR} parameters must be complied with simultaneously.
7. V_{CMR} min varies 1:1 with V_{EE} . V_{CMR} max varies 1:1 with V_{CC} . The V_{CMR} range is referenced to the most positive side of the differential input signal.

NB7L216

Table 5. AC CHARACTERISTICS ($V_{CC} = 2.375\text{ V to }3.465\text{ V}$, $V_{EE} = 0\text{ V}$; (Note 1))

Symbol	Characteristic	-40°C			25°C			85°C			Unit
		Min	Typ	Max	Min	Typ	Max	Min	Typ	Max	
V_{OUTPP}	Output Voltage Amplitude (@ $V_{INPPmin}$) $f_{in} \leq 7.0\text{ GHz}$ $f_{in} \leq 8.5\text{ GHz}$ (See Figure 4)	275 100	380 250		275 100	380 250		275 100	380 250		mV
f_{DATA}	Maximum Operating Data Rate	10	12		10	12		10	12		Gb/s
$ S_{21} $	Power Gain DC to 7 GHz		35		35			35			dB
$ S_{11} $	Input Return Loss @ 7 GHz		-10		-10			-10			dB
$ S_{22} $	Output Return Loss @ 7 GHz		-5		-5			-5			dB
$ S_{12} $	Reverse Isolation (Differential Configuration)		-25		-25			-25			dB
IIP3	Input Third Order Intercept		0		0			0			dBm
t_{PLH} , t_{PHL}	Propagation Delay to Output Differential @ 1 GHz	60	120	180	60	120	180	60	120	180	ps
t_{SKEW}	Duty Cycle Skew (Note 1) Device to Device Skew (Note 6)		2 5	10 20		2 5	10 20		2 5	10 20	ps
t_{JITTER}	RMS Random Clock Jitter $f_{in} \leq 8.5\text{ GHz}$ (Note 4) Peak-to-Peak Data Dependent Jitter (Note 5) $f_{DATA} = 3.5\text{ Gb/s}$ $f_{DATA} = 5.0\text{ Gb/s}$ $f_{DATA} = 10\text{ Gb/s}$ $f_{DATA} = 12\text{ Gb/s}$		0.1 1 3 4 4	0.5 7 9 9 9		0.1 1 3 4 4	0.5 7 9 9 9		0.1 1 3 4 4	0.5 7 9 9 9	ps
V_{INPP}	Input Voltage Swing/Sensitivity (Differential Configuration) (Note 3 and Figure 12)	20		2500	20		2500	20		2500	mV
t_r t_f	Output Rise/Fall Times @ 0.5 GHz (20% – 80%) Q, \bar{Q}		30	45		30	45		30	45	ps

NOTE: Device will meet the specifications after thermal equilibrium has been established when mounted in a test socket or printed circuit board with maintained airflow greater than 500 lfm. Electrical parameters are guaranteed only over the declared operating temperature range. Functional operation of the device exceeding these conditions is not implied. Device specification limit values are applied individually under normal operating conditions and not valid simultaneously.

1. Measured by forcing $V_{INPPmin}$ from a 50% duty cycle clock source. All loading with an external $R_L = 50\ \Omega$ to $V_{TT} = V_{CC} - 2.0\text{ V}$. Input edge rates 40 ps (20%– 80%).
2. Duty cycle skew is measured between differential outputs using the deviations of the sum of T_{pw-} and T_{pw+} @ 1 GHz.
3. V_{INPP} (MAX) cannot exceed $V_{CC} - V_{EE}$. Input voltage swing is a single-ended measurement operating in differential mode.
4. Additive RMS jitter with 50% duty cycle clock signal.
5. Additive peak-to-peak data dependent jitter with input NRZ data at PRBS 2²³-1.
6. Device to device skew is measured between outputs under identical transition @ 1 GHz.

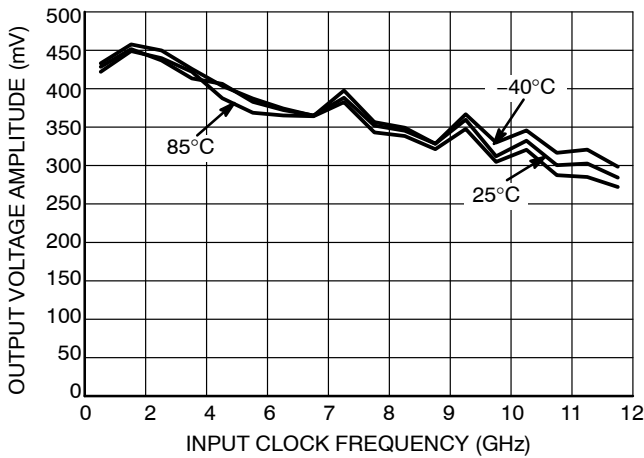

Figure 4. Output Voltage Amplitude (V_{OUTPP}) versus Input Clock Frequency (f_{IN}) and Temperature
($V_{INPP} = 400\text{ mV}$, $V_{CC} = 3.3\text{ V}$ and $V_{EE} = 0\text{ V}$)

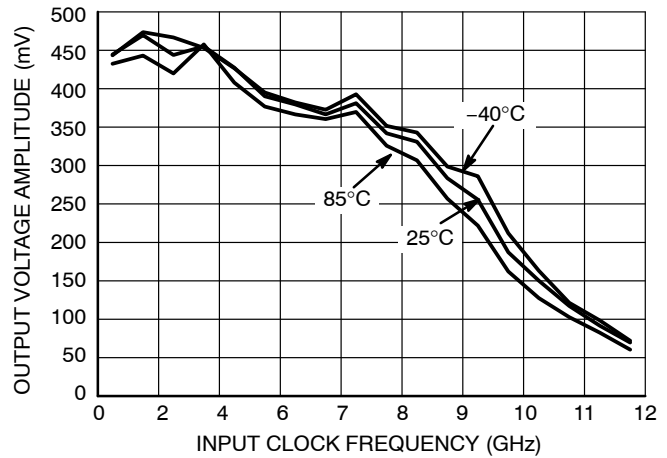

Figure 5. Output Voltage Amplitude (V_{OUTPP}) versus Input Clock Frequency (f_{IN}) and Temperature
($V_{INPP} = 20\text{ mV}$, $V_{CC} = 3.3\text{ V}$ and $V_{EE} = 0\text{ V}$)

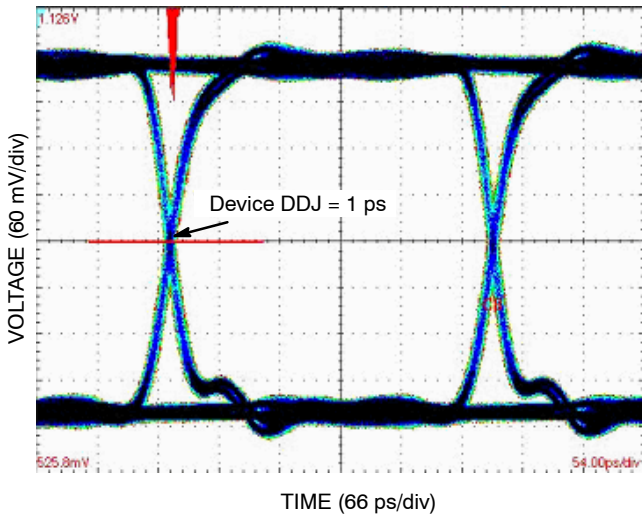

Figure 6. Typical Output Waveform at 2.488 Gb/s with PRBS $2^{23}-1$ ($V_{INPP} = 400$ mV, Input Signal DDJ = 12 ps)

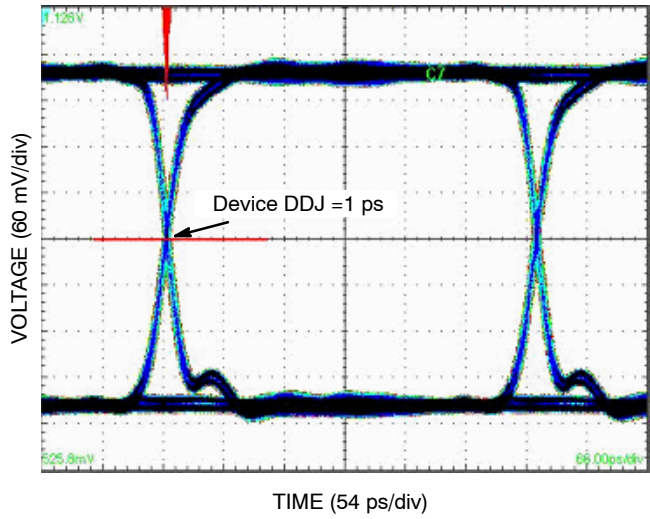

Figure 7. Typical Output Waveform at 3.5 Gb/s with PRBS $2^{23}-1$ ($V_{INPP} = 400$ mV, Input Signal DDJ = 12 ps)

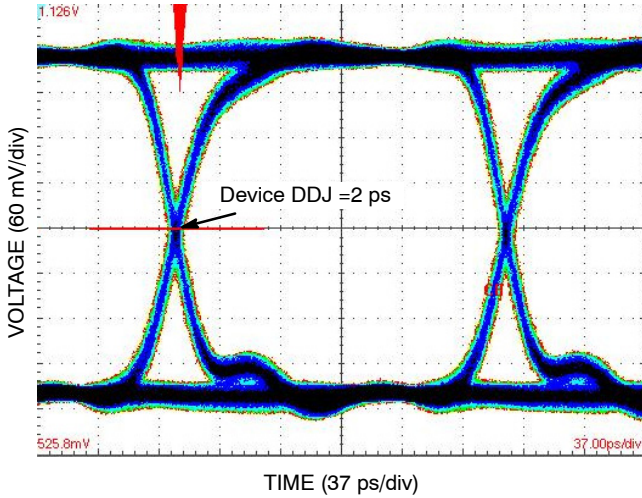

Figure 8. Typical Output Waveform at 5 Gb/s with PRBS $2^{23}-1$ ($V_{INPP} = 400$ mV, Input Signal DDJ = 12 ps)

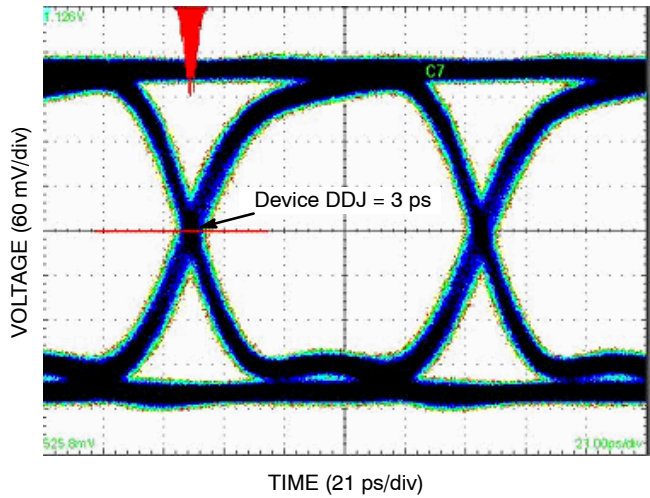

Figure 9. Typical Output Waveform at 10 Gb/s with PRBS $2^{23}-1$ ($V_{INPP} = 400$ mV, Input Signal DDJ = 12 ps)

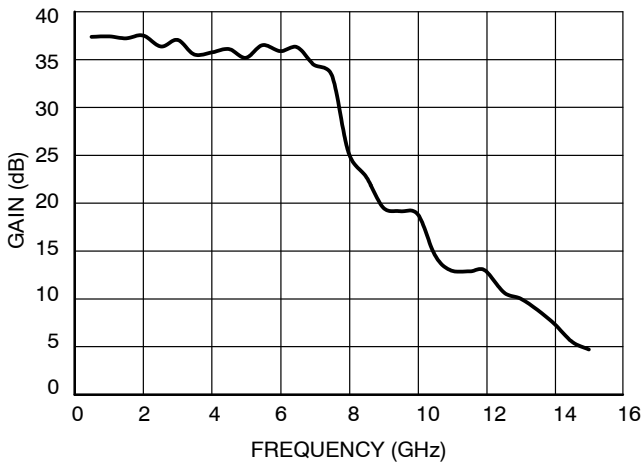

Figure 10. Small Signal Gain – S21 Magnitude*

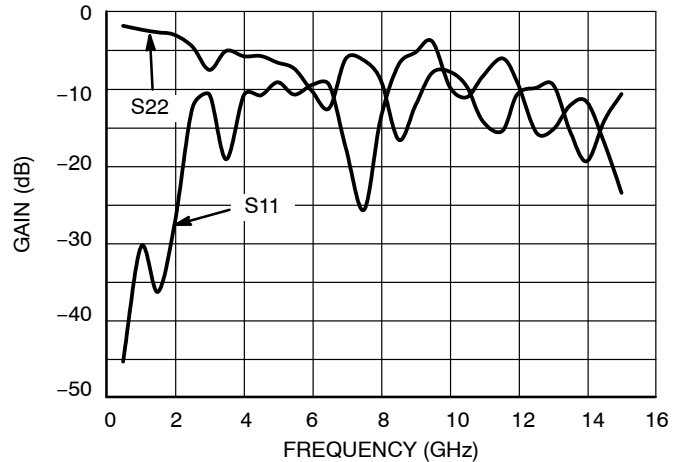

Figure 11. Input and Output Reflection – S11 and S22 Magnitude*

* $T_A = +25^\circ\text{C}$, $V_{CC} = 3.3$ V, $V_{EE} = 0$ V, $P_{IN} = -44$ dBm, $Z_S = Z_L = 50$ Ω , input and output matching network is not included.

NB7L216

Table 6. TYPICAL DEVICE S-PARAMETERS

Frequency (Hz)	S11			S21			S12			S22		
	dbS11	S11	∠S11	dbS21	S21	∠S21	dbS12	S12	∠S12	dbS22	S22	∠S22
4.97E+08	-45.2	0.005	-88.5	37.2	72.799	-33.2	-72.3	0.001	-139.1	-2.5	0.749	157.4
1.02E+09	-30.4	0.030	-134.7	37.3	73.145	-68.4	-45.8	0.005	129.8	-2.9	0.714	154.3
1.51E+09	-36.2	0.015	-146.5	37.1	71.433	-105.4	-43.3	0.007	98.5	-2.9	0.717	132.8
2.00E+09	-27.4	0.042	25.7	37.4	74.061	-139.0	-37.1	0.014	91.8	-3.5	0.666	107.1
2.52E+09	-12.3	0.244	-27.7	36.2	64.810	-179.5	-29.9	0.032	54.4	-4.4	0.599	92.1
3.01E+09	-10.6	0.295	-83.8	36.9	70.102	144.5	-26.1	0.050	9.4	-6.3	0.485	77.3
3.50E+09	-19.0	0.112	-22.1	35.4	58.933	99.9	-28.3	0.038	25.9	-5.0	0.566	67.9
4.02E+09	-10.6	0.294	-120.3	35.6	60.437	73.8	-24.8	0.058	-32.6	-7.6	0.417	54.2
4.51E+09	-10.7	0.291	167.4	36.0	62.843	41.1	-22.5	0.075	-68.3	-13.9	0.201	70.2
4.99E+09	-9.0	0.354	87.1	35.1	56.576	14.2	-25.2	0.055	-107.2	-8.7	0.367	81.2
5.48E+09	-10.6	0.294	62.7	36.4	65.812	-16.1	-24.3	0.061	-121.4	-8.0	0.398	50.4
6.01E+09	-9.3	0.341	108.2	35.8	61.327	-72.8	-24.5	0.060	-125.7	-8.0	0.397	-0.9
6.49E+09	-9.4	0.340	59.4	36.2	64.212	-119.4	-21.9	0.080	-152.4	-12.5	0.237	-27.2
6.98E+09	-17.5	0.133	25.5	34.3	52.039	-141.5	-22.7	0.073	177.5	-7.4	0.428	-32.2
7.51E+09	-25.6	0.053	107.9	33.2	45.861	164.6	-24.4	0.060	165.7	-7.0	0.445	-37.9
7.99E+09	-13.7	0.206	146.5	25.2	18.093	133.6	-21.5	0.084	152.8	-7.6	0.416	-54.7
8.52E+09	-6.7	0.462	117.9	22.6	13.434	116.2	-19.4	0.107	120.7	-12.1	0.249	-73.7
9.00E+09	-5.2	0.552	106.2	19.4	9.336	102.0	-19.0	0.112	109.9	-12.2	0.246	-62.5
9.49E+09	-3.7	0.652	71.1	19.0	8.937	61.1	-19.4	0.107	62.0	-11.5	0.267	-100.2
1.00E+10	-9.7	0.326	46.2	18.7	8.595	18.6	-24.0	0.063	50.6	-10.4	0.301	-117.0
1.05E+10	-11.0	0.283	35.8	14.5	5.298	-13.3	-25.9	0.051	12.9	-10.8	0.288	-172.0
1.10E+10	-8.3	0.384	7.2	12.9	4.408	-9.6	-29.4	0.034	21.1	-13.4	0.213	74.0
1.15E+10	-5.9	0.506	-0.4	12.7	4.339	-33.7	-21.4	0.085	36.3	-21.4	0.085	-148.6
1.20E+10	-9.0	0.356	-23.8	12.9	4.395	-63.4	-19.4	0.107	-9.5	-13.4	0.214	159.5
1.25E+10	-15.6	0.166	-46.9	10.5	3.360	-97.8	-21.0	0.089	-39.0	-12.4	0.239	169.2
1.30E+10	-15.1	0.175	-83.0	9.9	3.121	-119.7	-24.0	0.063	-39.9	-11.3	0.272	171.6
1.35E+10	-12.0	0.250	-96.5	8.7	2.728	-148.9	-22.0	0.079	-39.1	-14.9	0.181	177.8
1.40E+10	-11.5	0.265	-105.9	7.3	2.314	-167.1	-18.6	0.118	-74.2	-18.4	0.120	140.3
1.45E+10	-17.0	0.140	-97.8	5.4	1.856	167.6	-20.1	0.099	-107.0	-15.7	0.163	98.2
1.50E+10	-23.4	0.068	-108.9	4.6	1.695	145.0	-20.2	0.098	-128.1	-11.2	0.274	96.1

NOTE: $T_A = +25^\circ\text{C}$, $V_{CC} = 3.3\text{V}$, $V_{EE} = 0\text{V}$, $P_{IN} = -44\text{ dBm}$, $Z_S = Z_L = 50\ \Omega$, input and output matching network is not included.

NB7L216

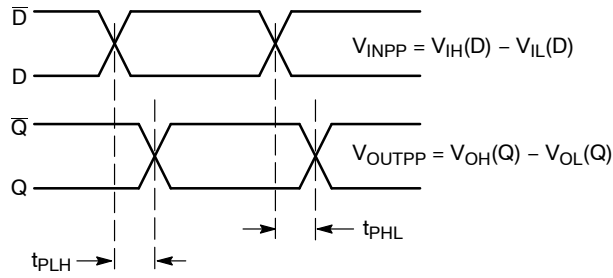

Figure 12. AC Reference Measurement

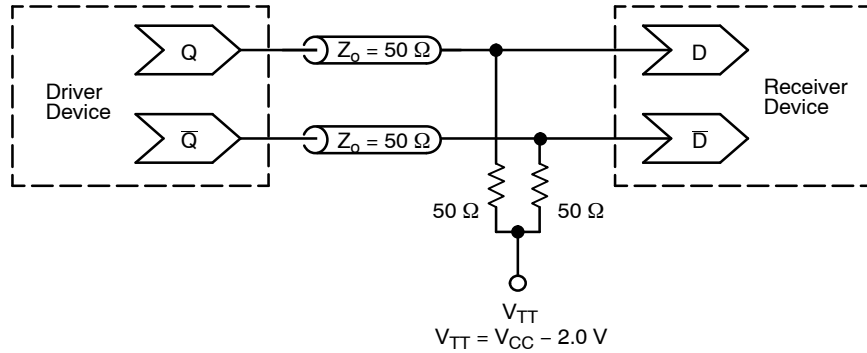

Figure 13. Typical Termination for Output Driver and Device Evaluation (See Application Note [AND8020/D](#) - Termination of ECL Logic Devices)

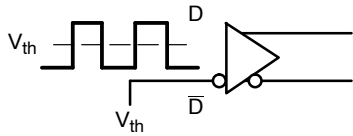

Figure 14. Differential Input Driven Single-Ended

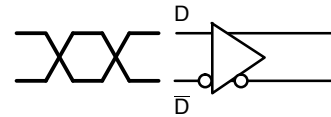

Figure 15. Differential Inputs Driven Differentially

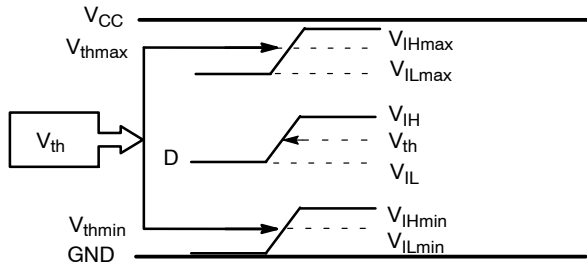

Figure 16. V_{th} Diagram

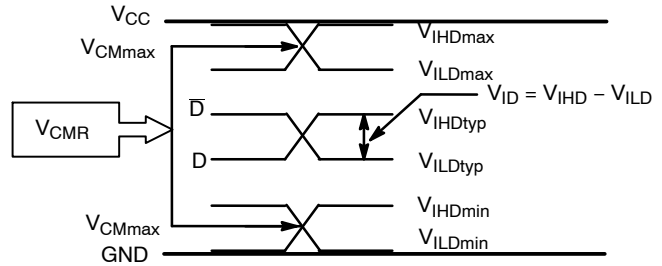

Figure 17. V_{CMR} Diagram

NOTE: $V_{EE} \leq V_{IN} \leq V_{CC}$; $V_{IH} > V_{IL}$

NB7L216

APPLICATION INFORMATION

All NB7L216 inputs can accept PECL, CML, LVTTTL, LVCMOS and LVDS signal levels. The limitations for differential input signal (LVDS, PECL, or CML) are minimum input swing of 75 mV and the maximum input swing of 2500 mV. Within these conditions, the input voltage can range from V_{CC} to 1.2 V. Examples interfaces are illustrated below in a 50 Ω environment ($Z = 50 \Omega$). For output termination and interface, refer to application note [AND8020/D](#).

Table 7. INTERFACING OPTIONS

Interfacing Options	Connections
CML	Connect VTD and \overline{VTD} to V_{CC} (See Figure 18)
LVDS	Connect VTD and \overline{VTD} Together (See Figure 20)
AC-COUPLED	Bias VTD and \overline{VTD} Inputs within Common Mode Range (V_{CMR}) (See Figure 19)
RSECL, PECL, NECL	Standard ECL Termination Techniques (See Figure 13)
LVTTTL, LVCMOS	An External Voltage (V_{THR}) should be Applied to the Unused Complementary Differential Input. Nominal V_{THR} is 1.5 V for LVTTTL and $V_{CC} / 2$ for LVCMOS Inputs. This Voltage must be within the V_{THR} Specification (See Figure 21)

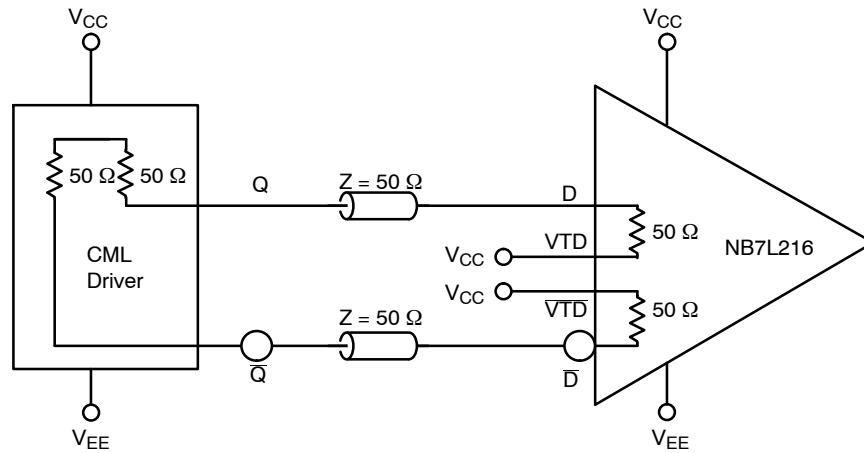
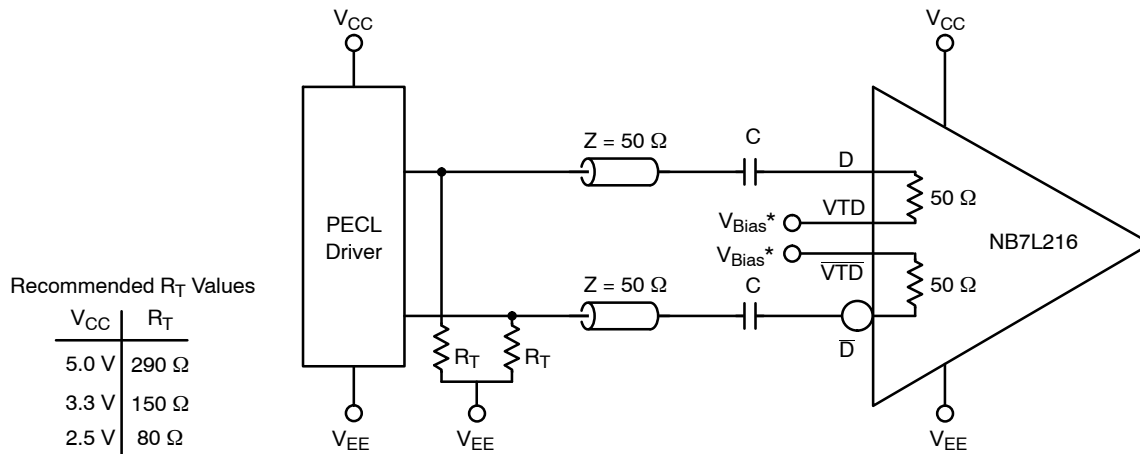

Figure 18. CML to NB7L216 Interface



* V_{Bias} must be within common mode range limits (V_{CMR})

Figure 19. PECL to NB7L216 Interface

NB7L216

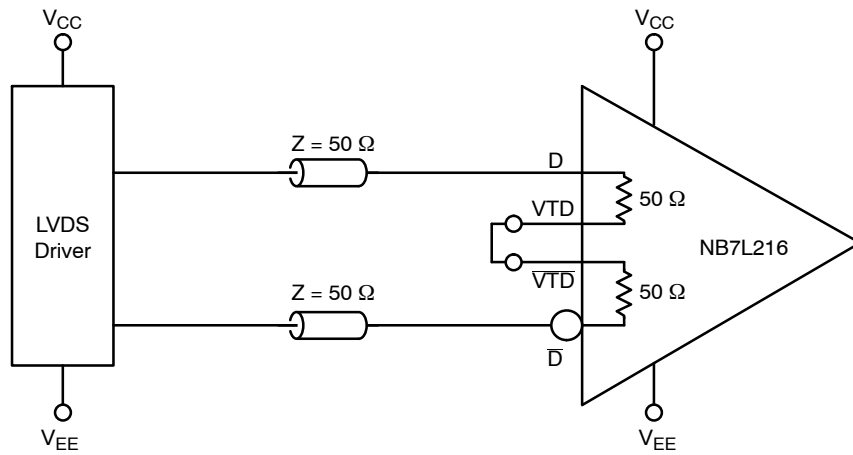

Figure 20. LVDS to NB7L216 Interface

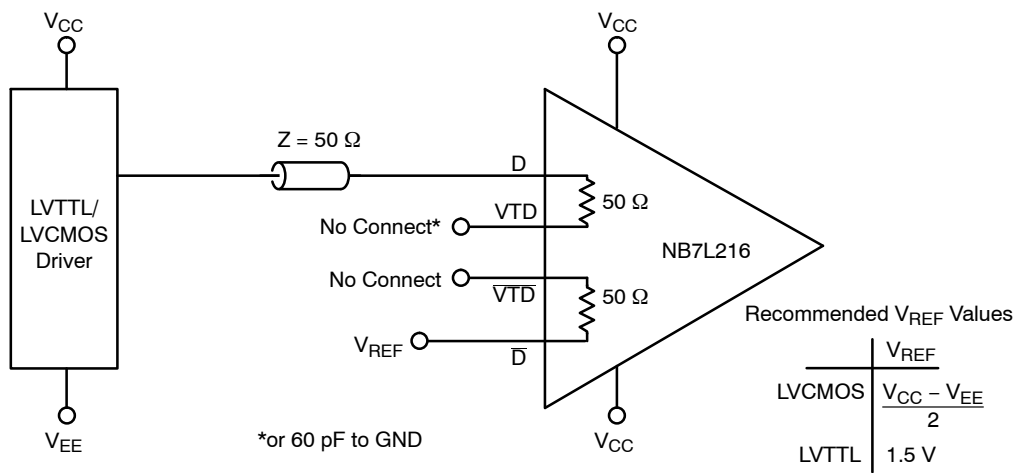
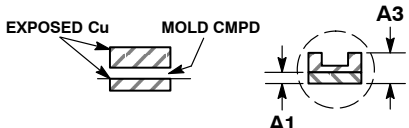
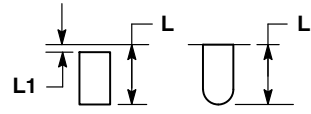
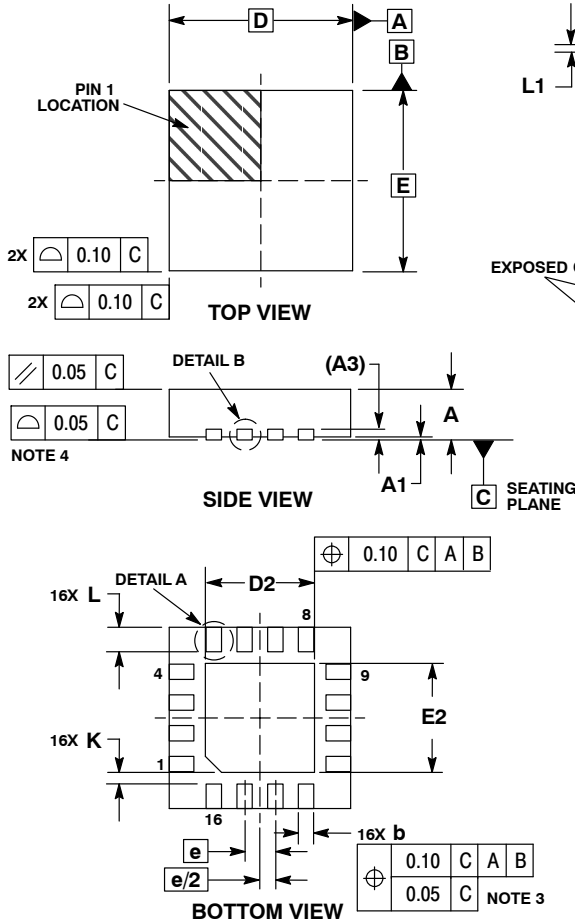

Figure 21. LVCMOS/LVTTL to NB7L216 Interface

NB7L216

PACKAGE DIMENSIONS

QFN-16 3x3, 0.5P
MN SUFFIX
CASE 485G
ISSUE F



NOTES:

1. DIMENSIONING AND TOLERANCING PER ASME Y14.5M, 1994.
2. CONTROLLING DIMENSION: MILLIMETERS.
3. DIMENSION b APPLIES TO PLATED TERMINAL AND IS MEASURED BETWEEN 0.25 AND 0.30 MM FROM TERMINAL.
4. COPLANARITY APPLIES TO THE EXPOSED PAD AS WELL AS THE TERMINALS.

MILLIMETERS			
DIM	MIN	NOM	MAX
A	0.80	0.90	1.00
A1	0.00	0.03	0.05
A3	0.20 REF		
b	0.18	0.24	0.30
D	3.00 BSC		
D2	1.65	1.75	1.85
E	3.00 BSC		
E2	1.65	1.75	1.85
e	0.50 BSC		
K	0.18 TYP		
L	0.30	0.40	0.50
L1	0.00	0.08	0.15

RECOMMENDED SOLDERING FOOTPRINT*

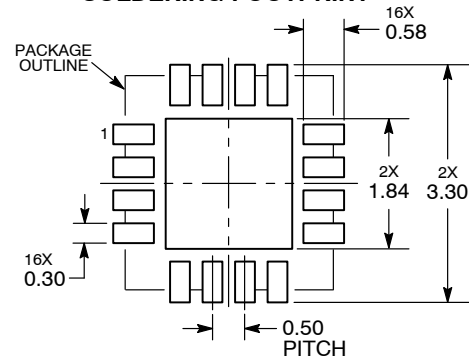

DIMENSIONS: MILLIMETERS

*For additional information on our Pb-Free strategy and soldering details, please download the ON Semiconductor Soldering and Mounting Techniques Reference Manual, SOLDERRM/D.

ECLinPS is a trademark of Semiconductor Components Industries, LLC (SCILLC) or its subsidiaries in the United States and/or other countries.

ON Semiconductor and are trademarks of Semiconductor Components Industries, LLC dba ON Semiconductor or its subsidiaries in the United States and/or other countries. ON Semiconductor owns the rights to a number of patents, trademarks, copyrights, trade secrets, and other intellectual property. A listing of ON Semiconductor's product/patent coverage may be accessed at www.onsemi.com/site/pdf/Patent-Marking.pdf. ON Semiconductor reserves the right to make changes without further notice to any products herein. ON Semiconductor makes no warranty, representation or guarantee regarding the suitability of its products for any particular purpose, nor does ON Semiconductor assume any liability arising out of the application or use of any product or circuit, and specifically disclaims any and all liability, including without limitation special, consequential or incidental damages. Buyer is responsible for its products and applications using ON Semiconductor products, including compliance with all laws, regulations and safety requirements or standards, regardless of any support or applications information provided by ON Semiconductor. "Typical" parameters which may be provided in ON Semiconductor data sheets and/or specifications can and do vary in different applications and actual performance may vary over time. All operating parameters, including "Typicals" must be validated for each customer application by customer's technical experts. ON Semiconductor does not convey any license under its patent rights nor the rights of others. ON Semiconductor products are not designed, intended, or authorized for use as a critical component in life support systems or any FDA Class 3 medical devices or medical devices with a same or similar classification in a foreign jurisdiction or any devices intended for implantation in the human body. Should Buyer purchase or use ON Semiconductor products for any such unintended or unauthorized application, Buyer shall indemnify and hold ON Semiconductor and its officers, employees, subsidiaries, affiliates, and distributors harmless against all claims, costs, damages, and expenses, and reasonable attorney fees arising out of, directly or indirectly, any claim of personal injury or death associated with such unintended or unauthorized use, even if such claim alleges that ON Semiconductor was negligent regarding the design or manufacture of the part. ON Semiconductor is an Equal Opportunity/Affirmative Action Employer. This literature is subject to all applicable copyright laws and is not for resale in any manner.

PUBLICATION ORDERING INFORMATION



LITERATURE FULFILLMENT:
 Literature Distribution Center for ON Semiconductor
 19521 E. 32nd Pkwy, Aurora, Colorado 80011 USA
Phone: 303-675-2175 or 800-344-3860 Toll Free USA/Canada
Fax: 303-675-2176 or 800-344-3867 Toll Free USA/Canada
Email: orderlit@onsemi.com

N. American Technical Support: 800-282-9855 Toll Free USA/Canada
Europe, Middle East and Africa Technical Support:
 Phone: 421 33 790 2910
Japan Customer Focus Center
 Phone: 81-3-5817-1050

ON Semiconductor Website: www.onsemi.com
Order Literature: <http://www.onsemi.com/orderlit>
 For additional information, please contact your local Sales Representative

Looking for pricing, stock, or lifecycle information?

Click below to explore more details on WIN SOURCE:

-  [View NB7L216MNG](#) on WIN SOURCE
-  [ON Semiconductor](#) Information

Optimize Your Supply Chain with WIN SOURCE Solutions

-  Global Sourcing Solution
-  Obsolete Management
-  Cost Control Management
-  Shortage Management
-  Alternative Solution
-  Excess Inventory Management