



**THE DATASHEET OF
TLV320AIC3263IYZFT**



Ultra Low Power Stereo Audio Codec With miniDSP, DirectPath Headphone, and Class-D Speaker Amplifier

Check for Samples: [TLV320AIC3263](#)

FEATURES

- Stereo Audio DAC with 101dB SNR
- 2.7mW Stereo 48kHz DAC Playback
- Stereo Audio ADC with 93dB SNR
- 6.1mW Stereo 48kHz ADC Record
- 8-192kHz Playback and Record
- 30mW DirectPath™ Headphone Driver Eliminates Large Output DC-Blocking Capacitors
- 128mW Differential Receiver Output Driver
- Class-D Speaker Driver
 - 1.7 W (8Ω , 5.5V, 10% THDN)
 - 1.4 W (8Ω , 5.5V, 1% THDN)
- Stereo Line Outputs
- PowerTune™ - Adjusts Power versus SNR
- Extensive Signal Processing Options
- Eight Single-Ended or 4 Fully-Differential Analog Inputs
- Analog Microphone Inputs, and Up to 4 Simultaneous Digital Microphone Channels
- Low Power Analog Bypass Mode
- Fully-programmable Enhanced miniDSP with PurePath™ Studio Support
 - Extensive Algorithm Support for Voice and Audio Applications
- Three Independent Digital Audio Serial Interfaces with Separate I/O Power Voltages
 - TDM and mono PCM support on all Audio Serial Interfaces
 - 8-channel Input and Output on Audio Serial Interface 1
- Programmable PLL, plus Low-Frequency Clocking
- Programmable 12-Bit SAR ADC
- SPI and I²C Control Interfaces
- 4.81 mm x 4.81 mm x 0.625 mm 81-Ball WCSP (DSBGA) Package

APPLICATIONS

- Mobile Handsets
- Tablets, eBooks
- Portable Navigation Devices (PND)
- Portable Media Player (PMP)
- Portable Gaming Systems
- Portable Computing
- Active Noise Cancellation (ANC)
- Speaker Protection
- Advanced DSP algorithms



Please be aware that an important notice concerning availability, standard warranty, and use in critical applications of Texas Instruments semiconductor products and disclaimers thereto appears at the end of this data sheet.

PowerTune is a trademark of Texas Instruments.

PRODUCTION DATA information is current as of publication date. Products conform to specifications per the terms of the Texas Instruments standard warranty. Production processing does not necessarily include testing of all parameters.

Copyright © 2013, Texas Instruments Incorporated

DESCRIPTION

The TLV320AIC3263 (also referred to as the AIC3263) is a flexible, highly-integrated, low-power, low-voltage stereo audio codec. The AIC3263 features four digital microphone inputs, plus programmable outputs, PowerTune capabilities, enhanced fully-programmable miniDSP, predefined and parameterizable signal processing blocks, integrated PLL, and flexible digital audio interfaces. Extensive register-based control of power, input and output channel configuration, gains, effects, pin-multiplexing and clocks are included, allowing the device to be precisely targeted to its application.

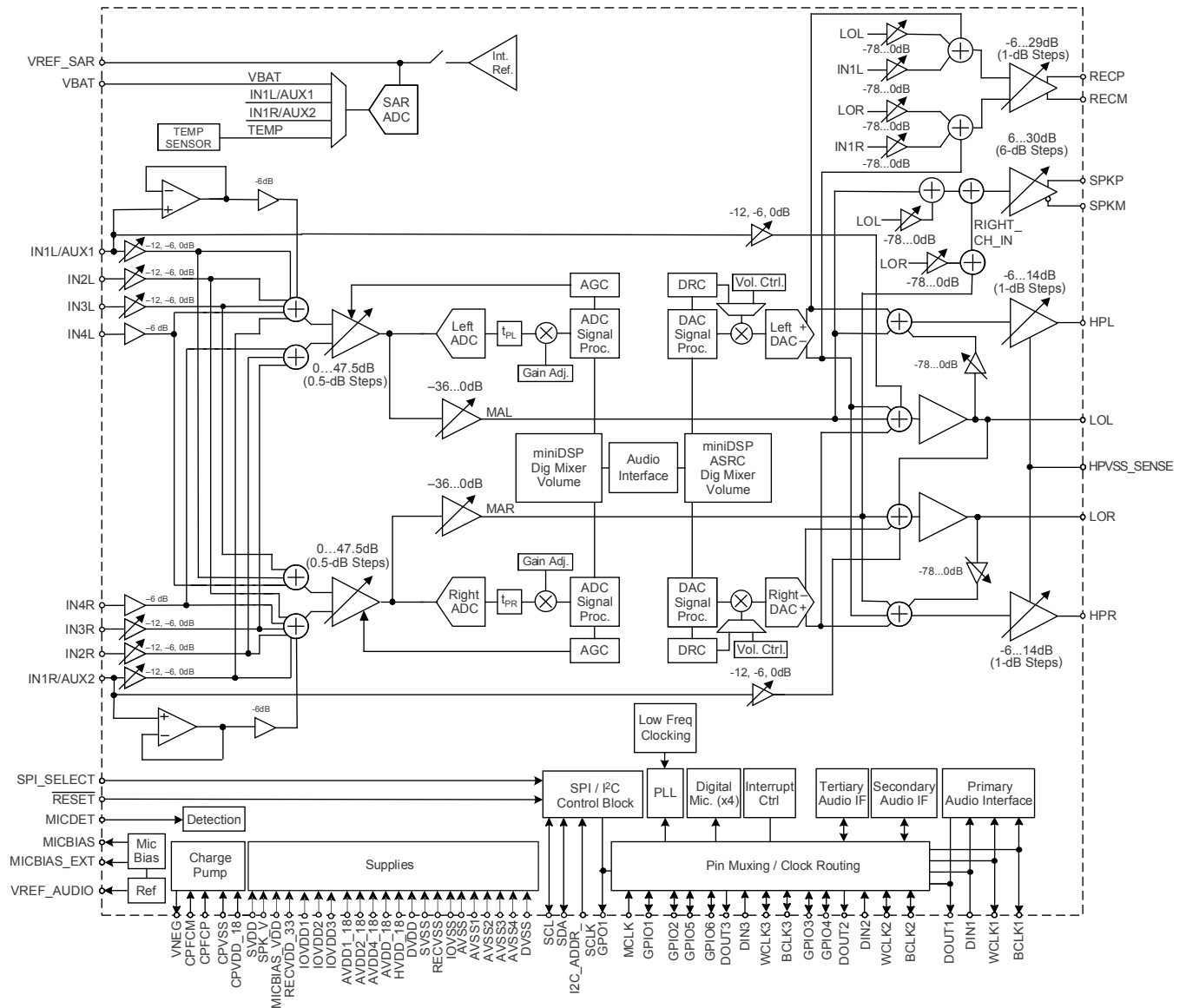

Figure 1. Simplified Block Diagram



This integrated circuit can be damaged by ESD. Texas Instruments recommends that all integrated circuits be handled with appropriate precautions. Failure to observe proper handling and installation procedures can cause damage.

ESD damage can range from subtle performance degradation to complete device failure. Precision integrated circuits may be more susceptible to damage because very small parametric changes could cause the device not to meet its published specifications.

DESCRIPTION (CONTINUED)

The TLV320AIC3263 features two fully-programmable miniDSP cores that support application-specific algorithms in the record and/or the playback path of the device. The miniDSP cores are fully software programmable. Targeted miniDSP algorithms, such as active noise cancellation, acoustic echo cancellation or advanced DSP filtering are loaded into the device after power-up.

Combined with the advanced PowerTune technology, the device can execute operations from 8kHz mono voice playback to stereo 192kHz DAC playback, making it ideal for portable battery-powered audio and telephony applications.

The record path of the TLV320AIC3263 covers operations from 8kHz mono to 192kHz stereo recording, and contains programmable input channel configurations which cover single-ended and differential setups, as well as floating or mixing input signals. It also provides a digitally-controlled stereo microphone preamplifier and integrated microphone bias. One application of the digital signal processing blocks is removable of audible noise that may be introduced by mechanical coupling, such as optical zooming in a digital camera. The record path can also be configured for up to two stereo (such as up to 4) simultaneous digital microphone Pulse Density Modulation (PDM) interfaces typically used at 64Fs or 128Fs.

The playback path offers signal processing blocks for filtering and effects; headphone, line, receiver, and Class-D speaker output; flexible mixing of DAC; and analog input signals as well as programmable volume controls. The playback path contains two high-power DirectPath™ headphone output drivers which eliminate the need for ac coupling capacitors. A built in charge pump generates the negative supply for the ground centered headphone drivers. These headphone output drivers can be configured in multiple ways, including stereo, and mono BTL. In addition, playback audio can be routed to an integrated Class-D speaker driver or a differential receiver amplifier.

The integrated PowerTune technology allows the device to be tuned to just the right power-performance trade-off. Mobile applications frequently have multiple use cases requiring very low-power operation while being used in a mobile environment. When used in a docked environment power consumption typically is less of a concern while lowest possible noise is important. With PowerTune the TLV320AIC3263 can address both cases.

The required internal clock of the TLV320AIC3263 can be derived from multiple sources, including the MCLK pin, the BCLK1 pin, the BCLK2 pin, several general purpose I/O pins or the output of the internal PLL, where the input to the PLL again can be derived from similar pins. Although using the internal fractional PLL ensures the availability of a suitable clock signal, it is not recommended for the lowest power settings. The PLL is highly programmable and can accept available input clocks in the range of 512kHz to 50MHz. To enable even lower clock frequencies, an integrated low-frequency clock multiplier can also be used as an input to the PLL.

The TLV320AIC3263 has a 12-bit SAR ADC converter that supports system voltage measurements. These system voltage measurements can be sourced from three dedicated analog inputs (IN1L/AUX1, IN1R/AUX2, or VBAT pins), or, alternatively, an on-chip temperature sensor that can be read by the SAR ADC.

The device also features three full Digital Audio Serial Interfaces, each supporting I2S, DSP/TDM, RJF, LJF, and mono PCM formats. This enables three simultaneous digital playback and record paths to three independent digital audio buses or chips. Additionally, the general purpose interrupt pins can be used to connect to a fourth digital audio bus, allowing the end system to easily switch in this fourth audio bus to one of the three Digital Audio Serial Interfaces. Each of the three Digital Audio Serial Interfaces can be run using separate power voltages to enable easy integration with separate chips with different I/O voltages.

The device is available in the 4.81 mm x 4.81 mm x 0.625 mm 81-Ball WCSP (DSBGA) Package.

Package and Signal Descriptions

Packaging/Ordering Information

PRODUCT ⁽¹⁾	PACKAGE	PACKAGE DESIGNATOR	OPERATING TEMPERATURE RANGE	ORDERING NUMBER	TRANSPORT MEDIA, QUANTITY
TLV320AIC3263	WCSP-81 (DSBGA)	YZF	-40°C to 85°C	TLV320AIC3263 I YZFT	Tape and Reel, 250
				TLV320AIC3263 I YZFR	Tape and Reel, 3000

(1) For the most current package and ordering information, see the Package Option Addendum at the end of this document, or visit the device product folder on www.ti.com.

Pin Assignments

**WCSP Package
(Top View)**

J	DVDD	WCLK2	WCLK3	BCLK3	SDA	IOVSS	DVDD	WCLK1	DIN1	
H	IOVDD2	DIN2	DIN3	IOVDD3	GPIO5	SCL	IOVDD1	DOUT1	BCLK1	
G	BCLK2	IOVSS	DOUT3	GPO1	GPIO6	RESET	GPIO2	GPIO1	MCLK	
F	DVSS	GPIO4	GPIO3	SPI_SELECT	I2C_ADDR_SCLK	DVSS	AVDD_18	IN2R	IN2L	
E	DVSS	DOUT2	DVDD	AVSS2	AVSS3	AVSS1	AVSS	IN3L	IN3R	
D	DVSS	VBAT	LOR	HPVSS_SENSE	IN4R	IN1R/AUX2	IN1L/AUX1	VREF_SAR	VREF_AUDIO	
C	SPK_V	SPKM	AVDD4_18	LOL	AVDD2_18	MICBIAS	MICBIAS_EXT	AVDD1_18	IN4L	
B	SVSS	SVDD	CPFCP	CPVSS	HPL	HVDD_18	RECM	RECP	MICDET	
A	SPKP	AVSS4	CPVDD_18	CPFCM	VNEG	HPR	RECVDD_33	RECVSS	MICBIAS_VDD	
		9	8	7	6	5	4	3	2	1

Figure 2. WCSP-81 (DSBGA) (YZF) Package Ball Assignments, Top View

Table 1. TERMINAL FUNCTIONS – 81 Ball WCSP (YZF) Package

WCSP (YZF) BALL LOCATION	NAME	I/O/P	POWER DOMAIN	DESCRIPTION
A1	MICBIAS_VDD	P	Analog	Power Supply for Micbias
A2	RECVSS	P	Analog	Receiver Driver Ground
A3	RECVDD_33	P	Analog	3.3V Power Supply for Receiver Driver
A4	HPR	O	Analog	Right Headphone Output
A5	VNEG	I/O	Analog	Charge Pump Negative Supply
A6	CPFCM	I/O	Analog	Charge Pump Flying Capacitor M terminal
A7	CPVDD_18	P	Analog	Power Supply Input for Charge Pump
A8	AVSS4	P	Analog	Analog Ground for Class-D
A9	SPKP	O	Speaker	Left Channel P side Class-D Output
B1	MICDET	I/O	Analog	Headset Detection Pin
B2	RECP	O	Analog	Receiver Driver P side Output
B3	RECM	O	Analog	Receiver Driver M side Output
B4	HVDD_18	P	Analog	Headphone Amp Power Supply
B5	HPL	O	Analog	Left Headphone Output
B6	CPVSS	P	Analog	Charge Pump Ground
B7	CPFCP	I/O	Analog	Charge Pump Flying Capacitor P Terminal
B8	SVDD	P	Speaker	Class-D Output Stage Power Supply
B9	SVSS	P	Speaker	Class-D Output Stage Ground
C1	IN4L	I	Analog	Analog Input 4 Left
C2	AVDD1_18	P	Analog	1.8V Analog Power Supply
C3	MICBIAS_EXT	O	Analog	Output Bias Voltage for Headset Microphone.
C4	MICBIAS	O	Analog	Output Bias Voltage for Microphone to be used for on-board Microphones
C5	AVDD2_18	P	Analog	1.8V Analog Power Supply
C6	LOL	O	Analog	Left Line Output
C7	AVDD4_18	P	Analog	1.8V Analog Power Supply for Class-D
C8	SPKM	O	Speaker	M side Class-D Output
C9	SPK_V	P	Speaker	Class-D Output Stage Power Supply (Connect to SVDD through a Resistor)
D1	VREF_AUDIO	O	Analog	Analog Reference Filter Output
D2	VREF_SAR	I/O	Analog	SAR ADC Voltage Reference Input or Internal SAR ADC Voltage Reference Bypass Capacitor Pin
D3	IN1L/AUX1	I	Analog	Analog Input 1 Left, Auxiliary 1 Input to SAR ADC (Special Function: Left Channel High Impedance Input for Capacitive Sensor Measurement)
D4	IN1R/AUX2	I	Analog	Analog Input 1 Right, Auxiliary 2 Input to SAR ADC (Special Function: Right Channel High Impedance Input for Capacitive Sensor Measurement)
D5	IN4R	I	Analog	Analog Input 4 Right
D6	HPVSS_SENSE	I	Analog	Headphone Ground Sense Terminal
D7	LOR	O	Analog	Right Line Output
D8	VBAT	I	Speaker	Battery Monitor Voltage Input
D9	DVSS	P	Digital	Digital Ground
E1	IN3R	I	Analog	Analog Input 3 Right
E2	IN3L	I	Analog	Analog Input 3 Left
E3	AVSS	P	Analog	Analog Ground
E4	AVSS1	P	Analog	Analog Ground
E5	AVSS3	P	Analog	Analog Ground
E6	AVSS2	P	Analog	Analog Ground
E7	DVDD	P	Digital	1.8V Digital Power Supply

Table 1. TERMINAL FUNCTIONS – 81 Ball WCSP (YZF) Package (continued)

WCSP (YZF) BALL LOCATION	NAME	I/O/P	POWER DOMAIN	DESCRIPTION
E8	DOUT2	O	IOVDD2	Primary: Audio Serial Data Bus 2 Data Output Secondary: See Table 8
E9	DVSS	P	Digital	Digital Ground
F1	IN2L	I	Analog	Analog Input 2 Left
F2	IN2R	I	Analog	Analog Input 2 Right
F3	AVDD_18	P	Analog	1.8V Analog Power Supply
F4	DVSS	P	Digital	Digital Ground
F5	I2C_ADDR_SCLK	I	IOVDD1	Primary: (SPI_SELECT = 1) SPI Serial Clock Secondary: (SPI_SELECT = 0) I ² C Address Bit (I2C_ADDR)
F6	SPI_SELECT	I	IOVDD1	Control Interface Select SPI_SELECT = '1': SPI Interface selected SPI_SELECT = '0': I ² C Interface selected
F7	GPIO3	I/O	IOVDD2	Multi Function Digital IO 3 See Table 9
F8	GPIO4	I/O	IOVDD2	Multi Function Digital IO 4 See Table 9
F9	DVSS	P	Digital	Digital Ground
G1	MCLK	I	IOVDD1	Master Clock Input
G2	GPIO1	I/O	IOVDD1	Multi Function Digital IO 1 See Table 9
G3	GPIO2	I/O	IOVDD1	Multi Function Digital IO 2 See Table 9
G4	RESET	I	IOVDD1	Active Low Reset
G5	GPIO6	I/O	IOVDD1	Multi Function Digital IO 6 See Table 9
G6	GPO1	O	IOVDD1	Multifunction Digital Output 1 Primary: (SPI_SELECT = 1) Serial Data Output Secondary: (SPI_SELECT = 0) See Table 9
G7	DOUT3	O	IOVDD3	Primary: Audio Serial Data Bus 3 Data Output Secondary: See Table 9
G8	IOVSS	P	Common for all IO Domains	Digital I/O Buffer Ground
G9	BCLK2	I/O	IOVDD2	Primary: Audio Serial Data Bus 2 Bit Clock Secondary: See Table 8

Table 1. TERMINAL FUNCTIONS – 81 Ball WCSP (YZF) Package (continued)

WCSP (YZF) BALL LOCATION	NAME	I/O/P	POWER DOMAIN	DESCRIPTION
H1	BCLK1	I/O	IOVDD1	Primary: Audio Serial Data Bus 1 Bit Clock Secondary: See Table 8
H2	DOUT1	O	IOVDD1	Primary: Audio Serial Data Bus 1 Data Output Secondary: See Table 8
H3	IOVDD1	P	IOVDD1	Digital I/O Buffer Supply 1
H4	SCL	I/O	IOVDD1	I ² C Interface Serial Clock (SPI_SELECT = 0) SPI interface mode chip-select signal (SPI_SELECT = 1)
H5	GPIO5	I/O	IOVDD1	Multifunction Digital IO 5 See Table 8
H6	IOVDD3	P	IOVDD3	Digital I/O Buffer Supply 3
H7	DIN3	I	IOVDD3	Primary: Audio Serial Data Bus 3 Data Input Secondary: See Table 9
H8	DIN2	I	IOVDD2	Primary: Audio Serial Data Bus 2 Data Input Secondary: See Table 8
H9	IOVDD2	P	IOVDD2	Digital I/O Buffer Supply 2
J1	DIN1	I	IOVDD1	Primary: Audio Serial Data Bus 1 Data Input Secondary: See Table 8
J2	WCLK1	I/O	IOVDD1	Primary: Audio Serial Data Bus 1 Word Clock Secondary: See Table 8
J3	DVDD	P	Digital	1.8V Digital Power Supply
J4	IOVSS	P	Common for all IO Domains	Digital I/O Buffer Ground
J5	SDA	I/O	IOVDD1	I ² C interface mode serial data input (SPI_SELECT = 0) SPI interface mode serial data input (SPI_SELECT = 1)
J6	BCLK3	I/O	IOVDD3	Primary: Audio Serial Data Bus 3 Bit Clock Secondary: See Table 9
J7	WCLK3	I/O	IOVDD3	Primary: Audio Serial Data Bus 3 Word Clock Secondary: See Table 9

Table 1. TERMINAL FUNCTIONS – 81 Ball WCSP (YZF) Package (continued)

WCSP (YZF) BALL LOCATION	NAME	I/O/P	POWER DOMAIN	DESCRIPTION
J8	WCLK2	I/O	IOVDD2	Primary: Audio Serial Data Bus 2 Word Clock Secondary: See Table 8
J9	DVDD	P	Digital	1.8V Digital Power Supply

Electrical Characteristics

Absolute Maximum Ratings

over operating free-air temperature range (unless otherwise noted) ⁽¹⁾

	VALUE	UNIT	
AVDD1_18, AVDD2_18, AVDD4_18, AVDD_18 to AVSS1, AVSS2, AVSS4, AVSS respectively ⁽²⁾	–0.3 to 2.2	V	
RECVDD_33 to RECVSS	–0.3 to 3.9	V	
DVDD to DVSS	–0.3 to 2.2	V	
IOVDDx to IOVSS	–0.3 to 3.9	V	
HVDD_18 to AVSS	–0.3 to 2.2	V	
CPVDD_18 to CPVSS	–0.3 to 2.2	V	
SVDD to SVSS, SPK_V to SVSS, and MICBIAS_VDD to AVSS3 ⁽³⁾	–0.3 to 6.0	V	
Digital Input voltage to ground	IOVSS – 0.3 to IOVDDx + 0.3	V	
Analog input voltage to ground	AVSS – 0.3 to AVDDx_18 + 0.3	V	
VBAT	–0.3 to 6	V	
Operating temperature range	–40 to 85	°C	
Storage temperature range	–55 to 125	°C	
Junction temperature (T _J Max)	105	°C	
WCSP-81 (DSBGA) package (YZF)	Power dissipation	(T _J Max – TA) / θ _{JA}	W
	θ _{JA} Junction-to-ambient thermal resistance	39.1	°C/W
	θ _{JCtop} Junction-to-case (top) thermal resistance	0.1	
	θ _{JB} Junction-to-board thermal resistance	12.0	
	Ψ _{JT} Junction-to-top characterization parameter	0.7	
	Ψ _{JB} Junction-to-board characterization parameter	11.5	

- (1) Stresses beyond those listed under “absolute maximum ratings” may cause permanent damage to the device. These are stress ratings only, and functional operation of the device at these or any other conditions beyond those indicated under “recommended operating conditions” is not implied. Exposure to absolute-maximum-rated conditions for extended periods may affect device reliability.
- (2) It's recommended to keep all AVDDx_18 supplies within ± 50 mV of each other.
- (3) It's recommended to keep SVDD and SPK_V supplies within ± 50 mV of each other.

Recommended Operating Conditions

			MIN	NOM	MAX	UNIT
AVDD1_18, AVDD2_18, AVDD4_18, AVDD_18	Power Supply Voltage Range	Referenced to AVSS1, AVSS2, AVSS4, AVSS respectively ⁽¹⁾ It is recommended to connect each of these supplies to a single supply rail.	1.5 ⁽²⁾	1.8	1.95	V
RECVDD_33			1.65 ⁽³⁾	3.3	3.6	
IOVDD1, IOVDD2, IOVDD3			1.1		3.6	
DVDD ⁽⁴⁾	Power Supply Voltage Range	Referenced to DVSS ⁽¹⁾	1.26	1.8	1.95	V
CPVDD_18	Power Supply Voltage Range	Referenced to CPVSS ⁽¹⁾	1.26	1.8	1.95	
HVDD_18		Referenced to AVSS ⁽¹⁾	1.5 ⁽³⁾	1.8	1.95	
		Ground-centered Configuration				
		Unipolar Configuration	1.65 ⁽³⁾		1.95	

- (1) All grounds on board are tied together, so they should not differ in voltage by more than 0.1V max, for any combination of ground signals. AVDDx_18 are within +/- 0.05 V of each other. SVDD and SPK_V are within +/- 0.05 V of each other.
- (2) For optimal performance with CM=0.9V, min AVDD = 1.8V.
- (3) Minimum voltage for HVDD_18 should be greater than or equal to AVDD2_18.
- (4) At DVDD values lower than 1.65V, the PLL and SAR ADC do not function. Please see table in SLAU475, *Maximum TLV320AIC3263 Clock Frequencies* for details on maximum clock frequencies.

Recommended Operating Conditions (continued)

			MIN	NOM	MAX	UNIT
SVDD ⁽¹⁾	Power Supply Voltage Range	Referenced to SVSS ⁽¹⁾	2.7		5.5	V
SPK_V ⁽¹⁾	Power Supply Voltage Range	Referenced to SVSS ⁽¹⁾	2.7		5.5	V
MICBIAS_VDD	Power Supply Voltage Range	Referenced to AVSS3 ⁽¹⁾	2.7		5.5	V
VREF_SAR	External voltage reference for SAR	Referenced to AVSS		1.8	AVDDx_18	V
	PLL Input Frequency ⁽⁵⁾	Clock divider uses fractional divide (D > 0), P=1, PLL_CLKIN_DIV=1, DVDD ≥ 1.65V (Refer to table in SLAU475, <i>Maximum TLV320AIC3263 Clock Frequencies</i>)	10		20	MHz
		Clock divider uses integer divide (D = 0), P=1, PLL_CLKIN_DIV=1, DVDD ≥ 1.65V (Refer to table in SLAU475, <i>Maximum TLV320AIC3263 Clock Frequencies</i>)	0.512		20	MHz
MCLK	Master Clock Frequency	MCLK; Master Clock Frequency; IOVDD ≥ 1.65V			50	MHz
		MCLK; Master Clock Frequency; IOVDD ≥ 1.1V			33	
SCL	SCL Clock Frequency				400	kHz
LOL, LOR	Stereo line output load resistance		0.6	10		kΩ
HPL, HPR	Stereo headphone output load resistance	Single-ended configuration	14.4	16		Ω
SPKP-SPKM	Speaker output load resistance	Differential	7.2	8		Ω
RECP-RECM	Receiver output resistance	Differential	24.4	32		Ω
C _{IN}	Charge pump input capacitor (CPVDD to CPVSS terminals)			10		μF
C _O	Charge pump output capacitor (VNEG terminal)	Type X7R		2.2		μF
C _F	Charge pump flying capacitor (CPFCP to CPFCM terminals)	Type X7R		2.2		μF
TOPR	Operating Temperature Range		-40		85	°C

(5) The PLL Input Frequency refers to clock frequency after PLL_CLKIN_DIV divider. Frequencies higher than 20MHz can be sent as an input to this PLL_CLKIN_DIV and reduced in frequency prior to input to the PLL.

Electrical Characteristics, SAR ADC

$T_A = 25^\circ\text{C}$; AVDD_18, AVDDx_18, HVDD_18, CPVDD_18, DVDD, IOVDDx = 1.8V; RECVDD_33 = 3.3V; SVDD, SPK_V, MICBIAS_VDD = 3.6V; f_S (Audio) = 48kHz; Audio Word Length = 20 bits; $C_{\text{ext}} = 1\mu\text{F}$ on VREF_SAR and VREF_AUDIO pins; PLL disabled unless otherwise noted.

PARAMETER		TEST CONDITIONS	MIN	TYP	MAX	UNIT
SAR ADC Inputs						
Analog Input	Input voltage range	IN1L/AUX1 or IN1R/AUX2 Selected	0	VREF_SAR		V
	Input impedance		$1 \div (f \times C_{\text{SAR_IN}})^{(1)}$			k Ω
	Input capacitance, $C_{\text{SAR_IN}}$		25			pF
	Input leakage current		1			μA
Battery Input	VBAT Input voltage range	VBAT (Battery measurement) selected ⁽²⁾	2.2		5.5	V
	VBAT Input impedance		5			k Ω
	VBAT Input capacitance		25			pF
	VBAT Input leakage current		1			μA
SAR ADC Conversion						
	Resolution	Programmable: 8-bit, 10-bit, 12-bit	8		12	Bits
	No missing codes	12-bit resolution		11		Bits
IN1L/AUX1	Integral linearity	12-bit resolution, SAR ADC clock = Internal Oscillator Clock, Conversion clock = Internal Oscillator / 4, External Reference = 1.8V ⁽³⁾		± 1		LSB
	Offset error			± 1		LSB
	Gain error			-0.09		%
	Noise	DC voltage applied to IN1L/AUX1 = 1 V, SAR ADC clock = Internal Oscillator Clock, Conversion clock = Internal Oscillator / 4, External Reference = 1.8V ⁽⁴⁾⁽³⁾		± 1		LSB
VBAT	Accuracy	12-bit resolution, SAR ADC clock = Internal Oscillator Clock, Conversion clock = Internal Oscillator / 4, Internal Reference = 1.25V		2		%
	Offset error			± 2		LSB
	Gain error			1.5		%
	Noise	DC voltage applied to VBAT = 3.6 V, 12-bit resolution, SAR ADC clock = Internal Oscillator Clock, Conversion clock = Internal Oscillator / 4, Internal Reference = 1.25V		± 0.5		LSB
Conversion Rate						
	Normal conversion operation	12-bit resolution, SAR ADC clock = 12 MHz External Clock, Conversion clock = External Clock / 4, External Reference = 1.8V ⁽³⁾ . With Fast SPI reading of data.			119	kHz
	High-speed conversion operation	8-bit resolution, SAR ADC clock = 12 MHz External Clock, Internal Conversion clock = External Clock (Conversion accuracy is reduced.), External Reference = 1.8V ⁽³⁾ . With Fast SPI reading of data.			250	kHz
Voltage Reference - VREF_SAR						
Voltage range	Internal VREF_SAR			1.25 \pm 0.05		V
	External VREF_SAR		1.25		AVDDx_18	V
Reference Noise	CM=0.9V, $C_{\text{ref}} = 1\mu\text{F}$			46		μV_{RMS}
Decoupling Capacitor				1		μF

(1) SAR input impedance is dependent on the sampling frequency (f designated in Hz), and the sampling capacitor is $C_{\text{SAR_IN}} = 25\text{pF}$.

(2) When VBAT is not being sampled/converted. When VBAT is being sampled, effective input impedance to GND is 5.24k Ω .

(3) When utilizing External SAR reference, this external reference should be restricted $V_{\text{EXT_SAR_REF}} \leq \text{AVDD}_{18}$ and AVDD_{2_18} .

(4) Noise from external reference voltage is excluded from this measurement.

Electrical Characteristics, ADC

$T_A = 25^\circ\text{C}$; AVDD_18, AVDDx_18, HVDD_18, CPVDD_18, DVDD, IOVDDx = 1.8V; RECVDD_33 = 3.3V; SVDD, SPK_V, MICBIAS_VDD = 3.6V; f_s (Audio) = 48kHz; Audio Word Length = 20 bits; $C_{\text{ext}} = 1\mu\text{F}$ on VREF_SAR and VREF_AUDIO pins; PLL disabled unless otherwise noted.

PARAMETER		TEST CONDITIONS	MIN	TYP	MAX	UNIT
AUDIO ADC (CM = 0.9V)						
	Input signal level (0dB)	Single-ended, CM = 0.9V		0.5		V_{RMS}
	Device Setup	1kHz sine wave input, Single-ended Configuration IN2R to Right ADC and IN2L to Left ADC, $R_{\text{in}} = 20\text{k}\Omega$, $f_s = 48\text{kHz}$, AOSR = 128, MCLK = $256 \cdot f_s$, PLL Disabled; AGC = OFF, Channel Gain = 0dB, Processing Block = PRB_R1, Power Tune = PTM_R4				
SNR	Signal-to-noise ratio, A-weighted ^{(1) (2)}	Inputs ac-shorted to ground	85	94		dB
		IN1R, IN3R, IN4R each exclusively routed in separate tests to Right ADC and ac-shorted to ground IN1L, IN3L, IN4L each exclusively routed in separate tests to Left ADC and ac-shorted to ground		94		
DR	Dynamic range A-weighted ^{(1) (2)}	–60dB full-scale, 1-kHz input signal		94		dB
THD+N	Total Harmonic Distortion plus Noise	–3 dB full-scale, 1-kHz input signal		–89	–75	dB
		IN1R, IN3R, IN4R each exclusively routed in separate tests to Right ADC IN1L, IN3L, IN4L each exclusively routed in separate tests to Left ADC –3dB full-scale, 1-kHz input signal		–88		
	Gain Error	1kHz sine wave input at –3dBFS, Single-ended configuration $R_{\text{in}} = 20\text{K}$ $f_s = 48\text{kHz}$, AOSR=128, MCLK = $256 \cdot f_s$, PLL Disabled AGC = OFF, Channel Gain=0dB, Processing Block = PRB_R1, Power Tune = PTM_R4, CM=0.9V		0.02		dB
	Input Channel Separation	1kHz sine wave input at –3dBFS, Single-ended configuration IN1L routed to Left ADC, IN1R routed to Right ADC, $R_{\text{in}} = 20\text{K}$ AGC = OFF, AOSR = 128, Channel Gain=0dB, CM=0.9V		110		dB
	Input Pin Crosstalk	1kHz sine wave input at –3dBFS on IN2L, IN2L internally not routed. IN1L routed to Left ADC, ac-coupled to ground 1kHz sine wave input at –3dBFS on IN2R, IN2R internally not routed. IN1R routed to Right ADC, ac-coupled to ground Single-ended configuration $R_{\text{in}} = 20\text{k}\Omega$, AOSR=128 Channel Gain=0dB, CM=0.9V		112		dB
	PSRR	217Hz, 100mVpp signal on AVDD_18, AVDDx_18 Single-ended configuration, $R_{\text{in}}=20\text{k}\Omega$, Channel Gain=0dB; CM=0.9V		59		dB

- (1) Ratio of output level with 1-kHz full-scale sine wave input, to the output level with the inputs short circuited, measured A-weighted over a 20-Hz to 20-kHz bandwidth using an audio analyzer.
- (2) All performance measurements done with pre-analyzer 20-kHz low-pass filter and, where noted, A-weighted filter. Failure to use such a filter may result in higher THD+N and lower SNR and dynamic range readings than shown in the Electrical Characteristics. The low-pass filter removes out-of-band noise, which, although not audible, may affect dynamic specification values

Electrical Characteristics, ADC (continued)

$T_A = 25^\circ\text{C}$; AVDD_18, AVDDx_18, HVDD_18, CPVDD_18, DVDD, IOVDDx = 1.8V; RECVDD_33 = 3.3V; SVDD, SPK_V, MICBIAS_VDD = 3.6V; f_s (Audio) = 48kHz; Audio Word Length = 20 bits; $C_{ext} = 1\mu\text{F}$ on VREF_SAR and VREF_AUDIO pins; PLL disabled unless otherwise noted.

PARAMETER		TEST CONDITIONS	MIN	TYP	MAX	UNIT
AUDIO ADC (CM = 0.75V)						
	Input signal level (0dB)	Single-ended, CM=0.75V, AVDD_18, AVDDx_18 = 1.5V		0.375		V _{RMS}
	Device Setup	1kHz sine wave input, Single-ended Configuration IN2R to Right ADC and IN2L to Left ADC, $R_{in} = 20\text{K}$, $f_s = 48\text{kHz}$, AOSR = 128, MCLK = $256 \cdot f_s$, PLL Disabled; AGC = OFF, Channel Gain = 0dB, Processing Block = PRB_R1, Power Tune = PTM_R4				
SNR	Signal-to-noise ratio, A-weighted ⁽³⁾ ⁽⁴⁾	Inputs ac-shortened to ground		91		dB
		IN1R, IN3R, IN4R each exclusively routed in separate tests to Right ADC and ac-shortened to ground IN1L, IN3L, IN4L each exclusively routed in separate tests to Left ADC and ac-shortened to ground		91		dB
DR	Dynamic range A-weighted ⁽³⁾ ⁽⁴⁾	−60dB full-scale, 1-kHz input signal		92		dB
THD+N	Total Harmonic Distortion plus Noise	−3dB full-scale, 1-kHz input signal		−85		dB

- (3) Ratio of output level with 1-kHz full-scale sine wave input, to the output level with the inputs short circuited, measured A-weighted over a 20-Hz to 20-kHz bandwidth using an audio analyzer.
- (4) All performance measurements done with pre-analyzer 20-kHz low-pass filter and, where noted, A-weighted filter. Failure to use such a filter may result in higher THD+N and lower SNR and dynamic range readings than shown in the Electrical Characteristics. The low-pass filter removes out-of-band noise, which, although not audible, may affect dynamic specification values

Electrical Characteristics, ADC (continued)

T_A = 25°C; AVDD₁₈, AVDDx₁₈, HVDD₁₈, CPVDD₁₈, DVDD, IOVDDx = 1.8V; RECVD₃₃ = 3.3V; SVDD, SPK_V, MICBIAS_VDD = 3.6V; f_S (Audio) = 48kHz; Audio Word Length = 20 bits; C_{ext} = 1µF on VREF_SAR and VREF_AUDIO pins; PLL disabled unless otherwise noted.

PARAMETER	TEST CONDITIONS	MIN	TYP	MAX	UNIT
AUDIO ADC (Differential Input, CM = 0.9V)					
Input signal level (0dB)	Differential, CM=0.9V, AVDD ₁₈ , AVDDx ₁₈ = 1.8V		1		V _{RMS}
Device Setup	1kHz sine wave input, Differential Configuration IN1L, IN1R Routed to Right ADC, IN2L, IN2R Routed to Left ADC R _{in} = 20kΩ, f _s = 48kHz, AOSR=128, MCLK = 256* f _s , PLL Disabled, AGC = OFF, Channel Gain = 0dB, Processing Block = PRB_R1, Power Tune = PTM_R4				
SNR	Signal-to-noise ratio, A-weighted ⁽⁵⁾ ⁽⁶⁾ Inputs ac-shorted to ground		94		dB
DR	Dynamic range A-weighted ⁽⁵⁾ ⁽⁶⁾ -60dB full-scale, 1-kHz input signal		95		dB
THD+N	Total Harmonic Distortion plus Noise -3dB full-scale, 1-kHz input signal		-89		dB
Gain Error	1kHz sine wave input at -3dBFS, Differential configuration R _{in} = 20kΩ, f _s = 48kHz, AOSR=128, MCLK = 256* f _s , PLL Disabled AGC = OFF, Channel Gain=0dB, Processing Block = PRB_R1, Power Tune = PTM_R4, CM=0.9V		0.04		dB
Input Channel Separation	1kHz sine wave input at -3dBFS, Differential configuration IN1L/IN1R differential signal routed to Right ADC, IN2L/IN2R differential signal routed to Left ADC, R _{in} = 20kΩ AGC = OFF, AOSR = 128, Channel Gain=0dB, CM=0.9V		108		dB
Input Pin Crosstalk	1kHz sine wave input at -3dBFS on IN2L/IN2R, IN2L/IN2R internally not routed. IN1L/IN1R differentially routed to Right ADC, ac-coupled to ground 1kHz sine wave input at -3dBFS on IN2L/IN2R, IN2L/IN2R internally not routed. IN3L/IN3R differentially routed to Left ADC, ac-coupled to ground Differential configuration R _{in} = 20kΩ, AOSR=128 Channel Gain=0dB, CM=0.9V		110		dB
PSRR	217Hz, 100mVpp signal on AVDD ₁₈ , AVDDx ₁₈ Differential configuration, Rin=20K, Channel Gain=0dB; CM=0.9V		52		dB
AUDIO ADC					
ADC programmable gain amplifier gain	IN1 - IN3, Single-Ended, Rin = 10K, PGA gain set to 0dB		0		dB
	IN1 - IN3, Single-Ended, Rin = 10K, PGA gain set to 47.5dB		47.5		dB
	IN1 - IN3, Single-Ended, Rin = 20K, PGA gain set to 0dB		-6		dB
	IN1 - IN3, Single-Ended, Rin = 20K, PGA gain set to 47.5dB		41.5		dB
	IN1 - IN3, Single-Ended, Rin = 40K, PGA gain set to 0dB		-12		dB
	IN1 - IN3, Single-Ended, Rin = 40K, PGA gain set to 47.5dB		35.5		dB
	IN4, Single-Ended, Rin = 20K, PGA gain set to 0dB		-6		dB
	IN4, Single-Ended, Rin = 20K, PGA gain set to 47.5dB		41.5		dB
ADC programmable gain amplifier step size	1-kHz tone		0.5		dB

- (5) Ratio of output level with 1-kHz full-scale sine wave input, to the output level with the inputs short circuited, measured A-weighted over a 20-Hz to 20-kHz bandwidth using an audio analyzer.
- (6) All performance measurements done with pre-analyzer 20-kHz low-pass filter and, where noted, A-weighted filter. Failure to use such a filter may result in higher THD+N and lower SNR and dynamic range readings than shown in the Electrical Characteristics. The low-pass filter removes out-of-band noise, which, although not audible, may affect dynamic specification values

Electrical Characteristics, Bypass Outputs

$T_A = 25^\circ\text{C}$; AVDD_18, AVDDx_18, HVDD_18, CPVDD_18, DVDD, IOVDDx = 1.8V; RECVDD_33 = 3.3V; SVDD, SPK_V, MICBIAS_VDD = 3.6V; f_S (Audio) = 48kHz; Audio Word Length = 20 bits; $C_{ext} = 1\mu\text{F}$ on VREF_SAR and VREF_AUDIO pins; PLL disabled unless otherwise noted.

PARAMETER	TEST CONDITIONS	MIN	TYP	MAX	UNIT
ANALOG BYPASS TO RECEIVER AMPLIFIER, DIRECT MODE					
Device Setup	Load = 32 Ω (differential), 56pF; Input CM=0.9V; Output CM=1.65V; IN1L routed to RECP and IN1R routed to RECM; Channel Gain=0dB				
Full scale differential input voltage (0dB)			1		V _{RMS}
Gain Error	707mVrms (-3dBFS), 1-kHz input signal		-0.7		dB
Noise, A-weighted ⁽¹⁾	Idle Channel, IN1L and IN1R ac-shorted to ground		12		μV_{RMS}
THD+N Total Harmonic Distortion plus Noise	707mVrms (-3dBFS), 1-kHz input signal		-89		dB
ANALOG BYPASS TO HEADPHONE AMPLIFIER, PGA MODE					
Device Setup	Load = 16 Ω (single-ended), 56pF; HVDD_18 = 3.3V Input CM=0.9V; Output CM=1.65V IN1L routed to ADCPGA_L, ADCPGA_L routed through MAL to HPL; and IN1R routed to ADCPGA_R, ADCPGA_R routed through MAR to HPR; R _{in} = 20K; Channel Gain = 0dB				
Full scale differential input voltage (0dB)			0.5		V _{RMS}
Gain Error	446mVrms (-1dBFS), 1-kHz input signal		-1.1		dB
Noise, A-weighted ⁽¹⁾	Idle Channel, IN1L and IN1R ac-shorted to ground		6.0		μV_{RMS}
THD+N Total Harmonic Distortion plus Noise	446mVrms (-1dBFS), 1-kHz input signal		-83		dB
ANALOG BYPASS TO HEADPHONE AMPLIFIER (GROUND-CENTERED CIRCUIT CONFIGURATION), PGA MODE					
Device Setup	Load = 16 Ω (single-ended), 56pF; Input CM=0.9V; IN1L routed to ADCPGA_L, ADCPGA_L routed through MAL to HPL; and IN1R routed to ADCPGA_R, ADCPGA_R routed through MAR to HPR; R _{in} = 20K; Channel Gain = 0dB				
Full scale input voltage (0dB)			0.5		V _{RMS}
Gain Error	446mVrms (-1dBFS), 1-kHz input signal		-1.0		dB
Noise, A-weighted ⁽¹⁾	Idle Channel, IN1L and IN1R ac-shorted to ground		11		μV_{RMS}
THD+N Total Harmonic Distortion plus Noise	446mVrms (-1dBFS), 1-kHz input signal		-71		dB

- (1) All performance measurements done with 20-kHz low-pass filter and, where noted, A-weighted filter. Failure to use such a filter may result in higher THD+N and lower SNR and dynamic range readings than shown in the Electrical Characteristics. The low-pass filter removes out-of-band noise, which, although not audible, may affect dynamic specification values

Electrical Characteristics, Bypass Outputs (continued)

T_A = 25°C; AVDD_18, AVDDx_18, HVDD_18, CPVDD_18, DVDD, IOVDDx = 1.8V; RECVDD_33 = 3.3V; SVDD, SPK_V, MICBIAS_VDD = 3.6V; f_S (Audio) = 48kHz; Audio Word Length = 20 bits; C_{ext} = 1µF on VREF_SAR and VREF_AUDIO pins; PLL disabled unless otherwise noted.

PARAMETER	TEST CONDITIONS	MIN	TYP	MAX	UNIT
ANALOG BYPASS TO LINE-OUT AMPLIFIER, PGA MODE					
Device Setup	Load = 10KOhm (single-ended), 56pF; Input and Output CM=0.9V; IN1L routed to ADCPGA_L and IN1R routed to ADCPGA_R; Rin = 20k ADCPGA_L routed through MAL to LOL and ADCPGA_R routed through MAR to LOR; Channel Gain = 0dB				
Full scale input voltage (0dB)			0.5		V _{RMS}
Gain Error	446mVrms (-1dBFS), 1-kHz input signal		-0.9		dB
Noise, A-weighted ⁽²⁾	Idle Channel, IN1L and IN1R ac-shorted to ground		5.9		µV _{RMS}
	Channel Gain=40dB, Inputs ac-shorted to ground, Input Referred		3.0		µV _{RMS}
ANALOG BYPASS TO LINE-OUT AMPLIFIER, DIRECT MODE					
Device Setup	Load = 10KOhm (single-ended), 56pF; Input and Output CM=0.9V; IN1L routed to LOL and IN1R routed to LOR; Channel Gain = 0dB				
Full scale input voltage (0dB)			0.5		V _{RMS}
Gain Error	446mVrms (-1dBFS), 1-kHz input signal		-0.4		dB
Noise, A-weighted ⁽²⁾	Idle Channel, IN1L and IN1R ac-shorted to ground		3.0		µV _{RMS}

(2) All performance measurements done with 20-kHz low-pass filter and, where noted, A-weighted filter. Failure to use such a filter may result in higher THD+N and lower SNR and dynamic range readings than shown in the Electrical Characteristics. The low-pass filter removes out-of-band noise, which, although not audible, may affect dynamic specification values

Electrical Characteristics, Microphone Interface

$T_A = 25^\circ\text{C}$; AVDD_18, AVDDx_18, HVDD_18, CPVDD_18, DVDD, IOVDDx = 1.8V; RECVDD_33 = 3.3V; SVDD, SPK_V, MICBIAS_VDD = 3.6V; f_S (Audio) = 48kHz; Audio Word Length = 20 bits; $C_{\text{ext}} = 1\mu\text{F}$ on VREF_SAR and VREF_AUDIO pins; PLL disabled unless otherwise noted.

PARAMETER	TEST CONDITIONS	MIN	TYP	MAX	UNIT
MICROPHONE BIAS (MICBIAS or MICBIAS_EXT)					
Bias voltage	CM=0.9V, MICBIAS_VDD = 3.3V				
	Micbias Mode 0		1.80		V
	Micbias Mode 1		2.00		V
	Micbias Mode 2		2.15		V
	Micbias Mode 3		2.49		V
	Micbias Mode 4 ⁽¹⁾		2.85		V
	Micbias Mode 5 ⁽¹⁾		3.00		V
	CM=0.75V, MICBIAS_VDD = 3.3V				
	Micbias Mode 0		1.50		V
	Micbias Mode 1		1.67		V
	Micbias Mode 2		1.79		V
	Micbias Mode 3		2.08		V
	Micbias Mode 4		2.37		V
	Micbias Mode 5		2.50		V
Output Noise	CM=0.9V, Micbias Mode 2, A-weighted, 20Hz to 20kHz bandwidth, Current load = 0mA.		10.04		μV_{RMS}
			70.99		nV/ $\sqrt{\text{Hz}}$
Current Sourcing	Micbias Mode 0, 1, 2, 3, 4, or 5 (CM=0.9V)		8		mA
Maximum Line Capacitance	Micbias Mode 0, 1, 2, 3, 4, or 5 (CM=0.9V) ⁽²⁾			10	pF
PSRR	217Hz, 100mVpp signal on AVDDx_18, DVDD, IOVDDx, MICBIAS_VDD=3.6V, CM=0.75V		48		dB
	217Hz, 100mVpp signal on MICBIAS_VDD, MICBIAS_VDD=3.6V, CM=0.75V		90		dB
	1kHz, 100mVpp signal on AVDDx_18, DVDD, IOVDDx, MICBIAS_VDD=3.6V, CM=0.75V		47		dB
	1kHz, 100mVpp signal on MICBIAS_VDD, MICBIAS_VDD=3.6V		85		dB

- (1) With Common Mode voltage of 0.9V, the MICBIAS_VDD voltage must be at minimum 3.05V to utilize Micbias Mode 4, and minimum of 3.2V to utilize Micbias Mode 5.
- (2) An explicit external capacitor should not be placed on MICBIAS or MICBIAS_EXT lines.

Electrical Characteristics, Audio DAC Outputs

$T_A = 25^\circ\text{C}$; AVDD_18, AVDDx_18, HVDD_18, CPVDD_18, DVDD, IOVDDx = 1.8V; RECVDD_33 = 3.3V; SVDD, SPK_V, MICBIAS_VDD = 3.6V; f_S (Audio) = 48kHz; Audio Word Length = 20 bits; $C_{\text{ext}} = 1\mu\text{F}$ on VREF_SAR and VREF_AUDIO pins; PLL disabled unless otherwise noted.

PARAMETER		TEST CONDITIONS	MIN	TYP	MAX	UNIT
AUDIO DAC – STEREO SINGLE-ENDED LINE OUTPUT						
Device Setup		Load = 10 k Ω (single-ended), 56pF Input and Output CM=0.9V DOSR = 128, MCLK=256* f_s , Channel Gain = 0dB, Processing Block = PRB_P1, Power Tune = PTM_P4				
	Full scale output voltage (0dB)			0.5		V _{RMS}
SNR	Signal-to-noise ratio A-weighted ^{(1) (2)}	All zeros fed to DAC input	85	101		dB
DR	Dynamic range, A-weighted ^{(1) (2)}	–60dB 1kHz input full-scale signal, Word length=20 bits		102		dB
THD+N	Total Harmonic Distortion plus Noise	–3dB full-scale, 1-kHz input signal		–92	–70	dB
	DAC Gain Error	–3dB full-scale, 1-kHz input signal		0.1		dB
	DAC Mute Attenuation	Mute		125		dB
	DAC channel separation	–1 dB, 1kHz signal, between left and right Line out		108		dB
DAC PSRR		100mVpp, 1kHz signal applied to AVDD_18, AVDDx_18		81		dB
		100mVpp, 217Hz signal applied to AVDD_18, AVDDx_18		79		dB
AUDIO DAC – STEREO SINGLE-ENDED LINE OUTPUT						
Device Setup		Load = 10 k Ω (single-ended), 56pF Input and Output CM=0.75V; AVDD_18, AVDDx_18, HVDD_18=1.5V DOSR = 128 MCLK=256* f_s Channel Gain = 0dB Processing Block = PRB_P1 Power Tune = PTM_P4				
	Full scale output voltage (0dB)			0.375		V _{RMS}
SNR	Signal-to-noise ratio, A-weighted ^{(1) (2)}	All zeros fed to DAC input		100		dB
DR	Dynamic range, A-weighted ^{(1) (2)}	–60dB 1 kHz input full-scale signal, Word length=20 bits		99		dB
THD+N	Total Harmonic Distortion plus Noise	–3 dB full-scale, 1-kHz input signal		–90		dB

- (1) Ratio of output level with 1kHz full-scale sine wave input, to the output level with the inputs short circuited, measured A-weighted over a 20Hz to 20kHz bandwidth using an audio analyzer.
- (2) All performance measurements done with 20kHz low-pass filter and, where noted, A-weighted filter. Failure to use such a filter may result in higher THD+N and lower SNR and dynamic range readings than shown in the Electrical Characteristics. The low-pass filter removes out-of-band noise, which, although not audible, may affect dynamic specification values.

Electrical Characteristics, Audio DAC Outputs (continued)

$T_A = 25^\circ\text{C}$; AVDD_18, AVDDx_18, HVDD_18, CPVDD_18, DVDD, IOVDDx = 1.8V; RECVDD_33 = 3.3V; SVDD, SPK_V, MICBIAS_VDD = 3.6V; f_S (Audio) = 48kHz; Audio Word Length = 20 bits; $C_{\text{ext}} = 1\mu\text{F}$ on VREF_SAR and VREF_AUDIO pins; PLL disabled unless otherwise noted.

PARAMETER	TEST CONDITIONS	MIN	TYP	MAX	UNIT
AUDIO DAC – MONO DIFFERENTIAL LINE OUTPUT					
Device Setup	Load = 10 k Ω (differential), 56pF Input and Output CM=0.9V, LOL signal routed to LOR amplifier DOSR = 128, MCLK=256* f_S , Channel Gain = 0dB, Processing Block = PRB_P1, Power Tune = PTM_P4				
Full scale output voltage (0dB)			1		V _{RMS}
SNR	Signal-to-noise ratio A-weighted ⁽³⁾ ⁽⁴⁾ All zeros fed to DAC input		101		dB
DR	Dynamic range, A-weighted ⁽³⁾ ⁽⁴⁾ –60dB 1kHz input full-scale signal,		101		dB
THD+N	Total Harmonic Distortion plus Noise –3dB full-scale, 1-kHz input signal		-91		dB
DAC Gain Error	–3dB full-scale, 1-kHz input signal		-0.03		dB
DAC Mute Attenuation	Mute		124		dB
DAC PSRR	100mVpp, 1kHz signal applied to AVDD_18, AVDDx_18		63		dB
	100mVpp, 217Hz signal applied to AVDD_18, AVDDx_18		63		dB

- (3) Ratio of output level with 1kHz full-scale sine wave input, to the output level with the inputs short circuited, measured A-weighted over a 20Hz to 20kHz bandwidth using an audio analyzer.
- (4) All performance measurements done with 20kHz low-pass filter and, where noted, A-weighted filter. Failure to use such a filter may result in higher THD+N and lower SNR and dynamic range readings than shown in the Electrical Characteristics. The low-pass filter removes out-of-band noise, which, although not audible, may affect dynamic specification values.

Electrical Characteristics, Audio DAC Outputs (continued)

$T_A = 25^\circ\text{C}$; AVDD_18, AVDDx_18, HVDD_18, CPVDD_18, DVDD, IOVDDx = 1.8V; RECVDD_33 = 3.3V; SVDD, SPK_V, MICBIAS_VDD = 3.6V; f_S (Audio) = 48kHz; Audio Word Length = 20 bits; $C_{ext} = 1\mu\text{F}$ on VREF_SAR and VREF_AUDIO pins; PLL disabled unless otherwise noted.

PARAMETER		TEST CONDITIONS	MIN	TYP	MAX	UNIT
AUDIO DAC – STEREO SINGLE-ENDED HEADPHONE OUTPUT (GROUND-CENTERED CIRCUIT CONFIGURATION)						
Device Setup		Load = 16 Ω (single-ended), 56pF, Input CM=0.9V; DOSR = 128, MCLK=256* f_S , Channel Gain = 0dB, Processing Block = PRB_P1, Power Tune = PTM_P3, Headphone Output Strength=100%				
Output 1	Output voltage			0.5		V_{RMS}
SNR	Signal-to-noise ratio, A-weighted ⁽⁵⁾ ₍₆₎	All zeros fed to DAC input	83	94		dB
DR	Dynamic range, A-weighted ⁽⁵⁾ ⁽⁶⁾	-60dB 1 kHz input full-scale signal		94		dB
THD+N	Total Harmonic Distortion plus Noise	-3dB full-scale, 1-kHz input signal		-75	-60	dB
	DAC Gain Error	-3dB, 1kHz input full scale signal		0.03		dB
	DAC Mute Attenuation	Mute		130		dB
	DAC channel separation	-3dB, 1kHz signal, between left and right HP out		80		dB
DAC PSRR		100mVpp, 1kHz signal applied to AVDD_18, AVDD1x_18		59		dB
		100mVpp, 217Hz signal applied to AVDD_18, AVDD1x_18		63		dB
	Power Delivered	THDN \leq -40dB, Load = 16 Ω		22		mW
Output 2	Output voltage	Load = 16 Ω (single-ended), Channel Gain = 5dB		0.8		V_{RMS}
SNR	Signal-to-noise ratio, A-weighted ⁽⁵⁾ ⁽⁶⁾	All zeros fed to DAC input, Load = 16 Ω		95		dB
	Power Delivered	THDN \leq -40dB, Load = 16 Ω		25		mW
Output 3	Output voltage	Load = 32 Ω (single-ended), Channel Gain = 5dB		0.9		V_{RMS}
SNR	Signal-to-noise ratio, A-weighted ⁽⁵⁾ ⁽⁶⁾	All zeros fed to DAC input, Load = 32 Ω		97		dB
	Power Delivered	THDN \leq -40dB, Load = 32 Ω		22		mW

(5) Ratio of output level with 1kHz full-scale sine wave input, to the output level with the inputs short circuited, measured A-weighted over a 20Hz to 20kHz bandwidth using an audio analyzer.

(6) All performance measurements done with 20kHz low-pass filter and, where noted, A-weighted filter. Failure to use such a filter may result in higher THD+N and lower SNR and dynamic range readings than shown in the Electrical Characteristics. The low-pass filter removes out-of-band noise, which, although not audible, may affect dynamic specification values.

Electrical Characteristics, Audio DAC Outputs (continued)

$T_A = 25^\circ\text{C}$; AVDD_18, AVDDx_18, HVDD_18, CPVDD_18, DVDD, IOVDDx = 1.8V; RECVD_33 = 3.3V; SVDD, SPK_V, MICBIAS_VDD = 3.6V; f_S (Audio) = 48kHz; Audio Word Length = 20 bits; $C_{\text{ext}} = 1\mu\text{F}$ on VREF_SAR and VREF_AUDIO pins; PLL disabled unless otherwise noted.

PARAMETER	TEST CONDITIONS	MIN	TYP	MAX	UNIT
AUDIO DAC – STEREO SINGLE-ENDED HEADPHONE OUTPUT (UNIPOLAR CIRCUIT CONFIGURATION)					
Device Setup	Load = 16Ω (single-ended), 56pF Input and Output CM=0.9V, DOSR = 128, MCLK=256* f_S , Channel Gain=0dB Processing Block = PRB_P1 Power Tune = PTM_P4 Headphone Output Control = 100%				
Full scale output voltage (0dB)			0.5		V_{RMS}
SNR	Signal-to-noise ratio, A-weighted ^{(7) (8)}	All zeros fed to DAC input	99		dB
DR	Dynamic range, A-weighted ^{(7) (8)}	-60dB 1kHz input full-scale signal, Power Tune = PTM_P4	99		dB
THD+N	Total Harmonic Distortion plus Noise	-3dB full-scale, 1-kHz input signal	-89	-65	dB
	DAC Gain Error	-3dB, 1kHz input full scale signal	-0.16		dB
	DAC Mute Attenuation	Mute	126		dB
	DAC channel separation	-1dB, 1kHz signal, between left and right HP out	119		dB
DAC PSRR	100mVpp, 1kHz signal applied to AVDD_18, AVDD1x_18		65		dB
	100mVpp, 217Hz signal applied to AVDD_18, AVDD1x_18		78		dB
Power Delivered	$R_L=16\Omega$ THDN \leq -40dB, Input CM=0.9V, Output CM=0.9V		16		mW

- (7) Ratio of output level with 1kHz full-scale sine wave input, to the output level with the inputs short circuited, measured A-weighted over a 20Hz to 20kHz bandwidth using an audio analyzer.
- (8) All performance measurements done with 20kHz low-pass filter and, where noted, A-weighted filter. Failure to use such a filter may result in higher THD+N and lower SNR and dynamic range readings than shown in the Electrical Characteristics. The low-pass filter removes out-of-band noise, which, although not audible, may affect dynamic specification values.

Electrical Characteristics, Audio DAC Outputs (continued)

$T_A = 25^\circ\text{C}$; AVDD_18, AVDDx_18, HVDD_18, CPVDD_18, DVDD, IOVDDx = 1.8V; RECVDD_33 = 3.3V; SVDD, SPK_V, MICBIAS_VDD = 3.6V; f_S (Audio) = 48kHz; Audio Word Length = 20 bits; $C_{\text{ext}} = 1\mu\text{F}$ on VREF_SAR and VREF_AUDIO pins; PLL disabled unless otherwise noted.

PARAMETER		TEST CONDITIONS	MIN	TYP	MAX	UNIT
AUDIO DAC – STEREO SINGLE-ENDED HEADPHONE OUTPUT (UNIPOLAR CIRCUIT CONFIGURATION)						
Device Setup		Load = 16 Ω (single-ended), 56pF, Input and Output CM=0.75V; AVDD_18, AVDDx_18, HVDD_18=1.5V, DOSR = 128, MCLK=256* f_S , Channel Gain = 0dB, Processing Block = PRB_P1, Power Tune = PTM_P4 Headphone Output Control = 100%				
Full scale output voltage (0dB)				0.375		V_{RMS}
SNR	Signal-to-noise ratio, A-weighted ⁽⁹⁾ (10)	All zeros fed to DAC input		99		dB
DR	Dynamic range, A-weighted ⁽⁹⁾ (10)	-60dB 1 kHz input full-scale signal		99		dB
THD+N	Total Harmonic Distortion plus Noise	-3dB full-scale, 1-kHz input signal		-90		dB
AUDIO DAC – MONO DIFFERENTIAL RECEIVER OUTPUT						
Device Setup		Load = 32 Ω (differential), 56pF, Output CM=1.65V, AVDDx_18=1.8V, DOSR = 128 MCLK=256* f_S , Left DAC routed to RECP, RECM, Channel (Receiver Driver) Gain = 6dB for full scale output signal, Processing Block = PRB_P4, Power Tune = PTM_P4				
Full scale output voltage (0dB)				2		V_{RMS}
SNR	Signal-to-noise ratio, A-weighted ⁽⁹⁾ (10)	All zeros fed to DAC input	87	102		dB
DR	Dynamic range, A-weighted ⁽⁹⁾ (10)	-60dB 1kHz input full-scale signal		102		dB
THD+N	Total Harmonic Distortion plus Noise	-3dB full-scale, 1-kHz input signal		-91	-70	dB
DAC PSRR		100mVpp, 1kHz signal applied to AVDD_18, AVDD1x_18		64		dB
		100mVpp, 217Hz signal applied to AVDD_18, AVDD1x_18		64		dB
Power Delivered		$R_L=32\Omega$ THDN \leq -40dB, Input CM=0.9V, Output CM=1.65V		123		mW

(9) Ratio of output level with 1kHz full-scale sine wave input, to the output level with the inputs short circuited, measured A-weighted over a 20Hz to 20kHz bandwidth using an audio analyzer.

(10) All performance measurements done with 20kHz low-pass filter and, where noted, A-weighted filter. Failure to use such a filter may result in higher THD+N and lower SNR and dynamic range readings than shown in the Electrical Characteristics. The low-pass filter removes out-of-band noise, which, although not audible, may affect dynamic specification values.

Electrical Characteristics, Class-D Outputs

$T_A = 25^\circ\text{C}$; AVDD_18, AVDDx_18, HVDD_18, CPVDD_18, DVDD, IOVDDx = 1.8V; RECVDD_33 = 3.3V; SVDD, SPK_V, MICBIAS_VDD = 3.6V; f_S (Audio) = 48kHz; Audio Word Length = 20 bits; $C_{\text{ext}} = 1\mu\text{F}$ on VREF_SAR and VREF_AUDIO pins; PLL disabled unless otherwise noted.

PARAMETER	TEST CONDITIONS		MIN	TYP	MAX	UNIT
DAC OUTPUT to CLASS-D SPEAKER OUTPUT; Load = 8Ω (Differential), 56pF+33μH						
Output voltage	SVDD=3.6, BTL measurement, DAC input = 0dBFS, class-D gain = 12dB, THD+N ≤ -20dB, CM=0.9V			2.64		V _{RMS}
SNR	Signal-to-noise ratio	SVDD=3.6V, BTL measurement, class-D gain = 6dB, measured as idle-channel noise, A-weighted (with respect to full-scale output value of 2 V _{rms}) ⁽¹⁾ ⁽²⁾ , CM=0.9V		91		dB
THD	Total harmonic distortion	SVDD=3.6V, BTL measurement, DAC input = 0dBFS, class-D gain = 6dB, CM=0.9V		-70		dB
THD+N	Total harmonic distortion + noise	SVDD=3.6V, BTL measurement, DAC input = 0dBFS, class-D gain = 6dB, CM=0.9V		-70		dB
PSRR	Power-supply rejection ratio	SVDD=3.6V, BTL measurement, ripple on SVDD = 200 mVp-p at 1 kHz, CM=0.9V		64		dB
		SVDD=3.6V, BTL measurement, ripple on SVDD = 200 mVp-p at 217 Hz, CM=0.9V		64		dB
	Mute attenuation	Analog Mute Only		92		dB
P _O	Maximum output power	THD+N = 10%, f = 1 kHz, Class-D Gain = 12 dB, CM = 0.9 V, R _L = 8 Ω	SVDD = 3.6 V	0.72		W
			SVDD = 4.2 V	0.99		
			SVDD = 5.5 V	1.68		
		THD+N = 1%, f = 1 kHz, Class-D Gain = 12 dB, CM = 0.9 V, R _L = 8 Ω	SVDD = 3.6 V	0.58		
			SVDD = 4.2 V	0.79		
			SVDD = 5.5 V	1.36		
DAC OUTPUT to CLASS-D SPEAKER OUTPUT; Load = 8Ω (Differential), 56pF+33μH						
Output voltage	SVDD=5.0V, BTL measurement, DAC input = 0dBFS, class-D gain = 12dB, THD+N ≤ -20dB, CM=0.9V			3.40		V _{RMS}
SNR	Signal-to-noise ratio	SVDD=5.0V, BTL measurement, class-D gain = 6dB, measured as idle-channel noise, A-weighted (with respect to full-scale output value of 2 V _{rms}) ⁽¹⁾ ⁽²⁾ , CM=0.9V		92		
THD	Total harmonic distortion	SVDD=5.0V, BTL measurement, DAC input = 0dBFS, class-D gain = 6dB, CM=0.9V		-72		
THD+N	Total harmonic distortion + noise	SVDD=5.0V, BTL measurement, DAC input = 0dBFS, class-D gain = 6dB, CM=0.9V		-72		
PSRR	Power-supply rejection ratio	SVDD=5.0V, BTL measurement, ripple on SVDD = 200mVp-p at 1kHz, CM=0.9V		60		
		SVDD=5.0V, BTL measurement, ripple on SVDD = 200 mVp-p at 217 Hz, CM=0.9V		60		
	Mute attenuation	Analog Mute Only		93		dB
P _O	Maximum output power	THD+N = 10%, f = 1 kHz, Class-D Gain = 12 dB, CM = 0.9 V, R _L = 8 Ω	SVDD = 5.0 V	1.40		W

(1) Ratio of output level with 1kHz full-scale sine wave input, to the output level with the inputs short circuited, measured A-weighted over a 20Hz to 20kHz bandwidth using an audio analyzer.

(2) All performance measurements done with 20kHz low-pass filter and, where noted, A-weighted filter. Failure to use such a filter may result in higher THD+N and lower SNR and dynamic range readings than shown in the Electrical Characteristics. The low-pass filter removes out-of-band noise, which, although not audible, may affect dynamic specification values.

Electrical Characteristics, Misc.

T_A = 25°C; AVDD_18, AVDDx_18, HVDD_18, CPVDD_18, DVDD, IOVDDx = 1.8V; RECVDD_33 = 3.3V; SVDD, SPK_V, MICBIAS_VDD = 3.6V; f_S (Audio) = 48kHz; Audio Word Length = 20 bits; C_{ext} = 1µF on VREF_SAR and VREF_AUDIO pins; PLL disabled unless otherwise noted.

PARAMETER	TEST CONDITIONS	MIN	TYP	MAX	UNIT
REFERENCE - VREF_AUDIO					
Reference Voltage Settings	CMMode = 0 (0.9V)		0.9		V
	CMMode = 1 (0.75V)		0.75		
Reference Noise	CM=0.9V, A-weighted, 20Hz to 20kHz bandwidth, C _{ref} = 1µF		1.62		µV _{RMS}
Decoupling Capacitor			1		µF
miniDSP⁽¹⁾					
miniDSP clock frequency - ADC	DVDD = 1.26V			37.5	MHz
miniDSP clock frequency - DAC	DVDD = 1.26V			35.0	MHz
miniDSP clock frequency - ADC	DVDD = 1.65V			63	MHz
miniDSP clock frequency - DAC	DVDD = 1.65V			59.0	MHz
miniDSP clock frequency - ADC	DVDD = 1.71V			69	MHz
miniDSP clock frequency - DAC	DVDD = 1.71V			62.5	MHz
Shutdown Power					
Device Setup	Coarse AVdd supply turned off, All External analog supplies powered and set available, No external digital input is toggled, register values are retained.				
P(total) ⁽²⁾	Sum of all supply currents, all supplies at 1.8 V except for SVDD = SPK_V = MICBIAS_VDD = 3.6 V and RECVDD_33 = 3.3 V		9.8		µW
I(DVDD)			2.6		µA
I(IOVDD1, IOVDD2, IOVDD3)			0.15		µA
I(AVDD1_18, AVDD2_18, AVDD4_18, AVDD_18, HVDD_18, CPVDD_18)			1.15		µA
I(RECVDD_33)			0.15		µA
I(SVDD, SPK_V, MICBIAS_VDD)			0.5		µA

- (1) miniDSP clock speed is specified by design and not tested in production.
- (2) For further details on playback and recording power consumption, refer to PowerTune section in SLAU475.

Electrical Characteristics, Logic Levels, IOVDDx

T_A = 25°C; AVDD_18, AVDDx_18, HVDD_18, CPVDD_18, DVDD, IOVDDx = 1.8V; RECVDD_33 = 3.3V; SVDD, SPK_V, MICBIAS_VDD = 3.6V; f_S (Audio) = 48kHz; Audio Word Length = 20 bits; C_{ext} = 1µF on VREF_SAR and VREF_AUDIO pins; PLL disabled unless otherwise noted.

PARAMETER	TEST CONDITIONS	MIN	TYP	MAX	UNIT
LOGIC FAMILY					
CMOS					
V _{IH} Logic Level	I _{IH} = 5 µA, IOVDDx > 1.65V	0.7 × IOVDDx			V
	I _{IH} = 5µA, 1.2V ≤ IOVDDx <1.65V	0.9 × IOVDDx			V
	I _{IH} = 5µA, IOVDDx < 1.2V	IOVDDx			V
V _{IL}	I _{IL} = 5 µA, IOVDDx > 1.65V	-0.3	0.3 × IOVDDx		V
	I _{IL} = 5µA, 1.2V ≤ IOVDDx <1.65V		0.1 × IOVDDx		V
	I _{IL} = 5µA, IOVDDx < 1.2V			0	V
V _{OH}	I _{OH} = 3mA load, IOVDDx > 1.65V	0.8 × IOVDDx			V
	I _{OH} = 1mA load, IOVDDx < 1.65V	0.8 × IOVDDx			V
V _{OL}	I _{OL} = 3mA load, IOVDDx > 1.65V		0.1 × IOVDDx		V
	I _{OL} = 1mA load, IOVDDx < 1.65V		0.1 × IOVDDx		V
Capacitive Load			10		pF

Interface Timing

Note: All timing specifications are measured at characterization but not tested at final test. The audio serial interface timing specifications are applied to Audio Serial Interface 1, Audio Serial Interface 2 and Audio Serial Interface 3.

Typical Timing Characteristics — Audio Data Serial Interface Timing (I²S)

WCLK represents WCLK1 pin for Audio Serial Interface 1 BCLK represents BCLK1 pin for Audio Serial Interface 1 DOUT represents DOUT1 pin for Audio Serial Interface 1 DIN represents DIN1 pin for Audio Serial Interface 1 Specifications are at 25° C with DVDD = 1.8V and IOVDDx = 1.8 V.

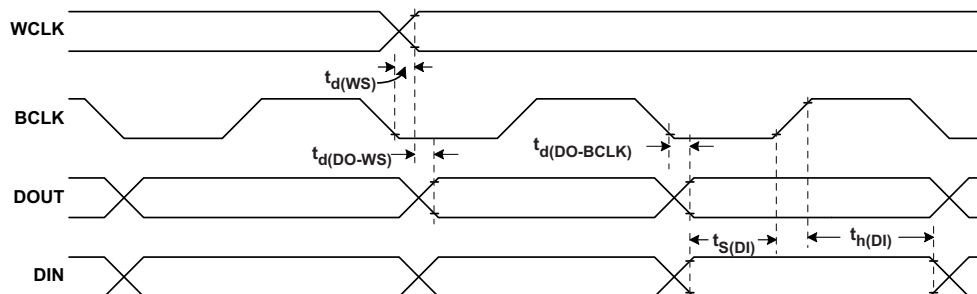

Figure 3. I²S/LJF/RJF Timing in Master Mode

Table 2. I²S/LJF/RJF Timing in Master Mode (see Figure 3)

PARAMETER		IOVDDx=1.8V		IOVDDx=3.3V		UNITS
		MIN	MAX	MIN	MAX	
$t_d(WS)$	WCLK delay		22		20	ns
$t_d(DO-WS)$	WCLK to DOUT delay (For LJF Mode only)		22		20	ns
$t_d(DO-BCLK)$	BCLK to DOUT delay		22		20	ns
$t_s(DI)$	DIN setup	4		4		ns
$t_h(DI)$	DIN hold	4		4		ns
t_r	BCLK Rise time		10		8	ns
t_f	BCLK Fall time		10		8	ns

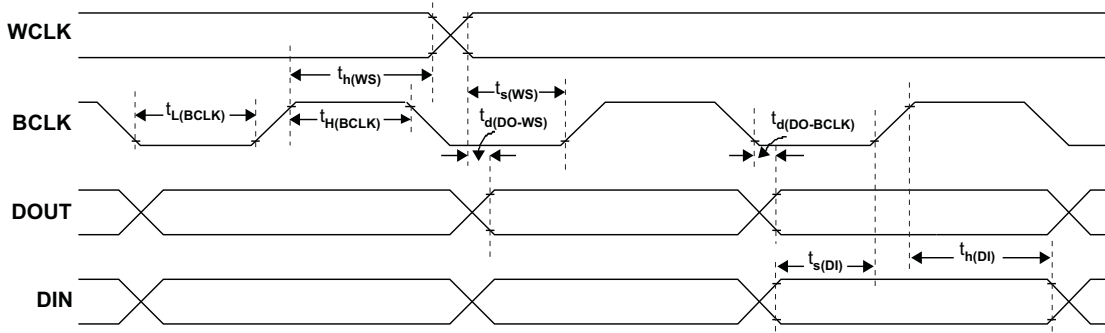

Figure 4. I²S/LJF/RJF Timing in Slave Mode

Table 3. I²S/LJF/RJF Timing in Slave Mode (see Figure 4)

PARAMETER		IOVDDx=1.8V		IOVDDx=3.3V		UNITS
		MIN	MAX	MIN	MAX	
t _H (BCLK)	BCLK high period	30		30		ns
t _L (BCLK)	BCLK low period	30		30		
t _s (WS)	WCLK setup	4		4		
t _h (WS)	WCLK hold	4		4		
t _d (DO-WS)	WCLK to DOUT delay (For LJF mode only)		22		20	
t _d (DO-BCLK)	BCLK to DOUT delay		22		20	
t _s (DI)	DIN setup	4		4		
t _h (DI)	DIN hold	4		4		
t _r	BCLK Rise time		5		4	
t _f	BCLK Fall time		5		4	

Typical DSP Timing Characteristics

Specifications are at 25° C with DVDD = 1.8 V.

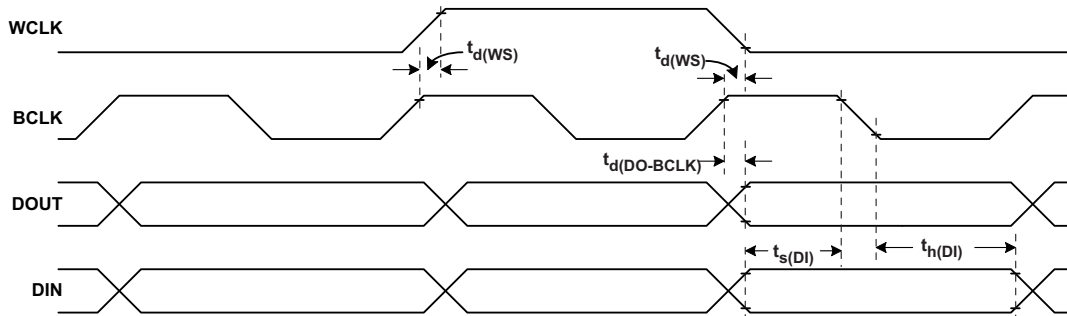

Figure 5. DSP/Mono PCM Timing in Master Mode

Table 4. DSP/Mono PCM Timing in Master Mode (see Figure 5)

PARAMETER		IOVDDx=1.8V		IOVDDx=3.3V		UNITS
		MIN	MAX	MIN	MAX	
$t_d(WS)$	WCLK delay		22		20	ns
$t_d(DO-BCLK)$	BCLK to DOUT delay		22		20	ns
$t_s(DI)$	DIN setup	4		4		ns
$t_h(DI)$	DIN hold	4		4		ns
t_r	BCLK Rise time		10		8	ns
t_f	BCLK Fall time		10		8	ns

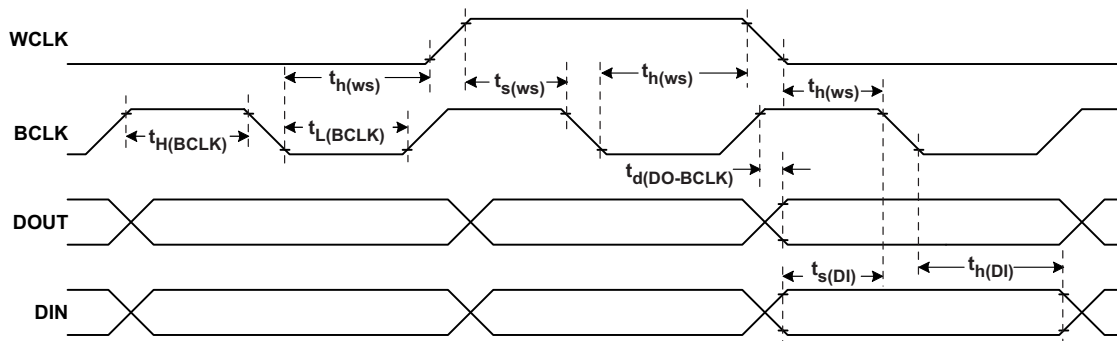

Figure 6. DSP/Mono PCM Timing in Slave Mode

Table 5. DSP/Mono PCM Timing in Slave Mode (see Figure 6)

PARAMETER		IOVDDx=1.8V		IOVDDx=3.3V		UNITS
		MIN	MAX	MIN	MAX	
$t_H(BCLK)$	BCLK high period	30		30		ns
$t_L(BCLK)$	BCLK low period	30		30		ns
$t_s(WS)$	WCLK setup	4		4		ns
$t_h(WS)$	WCLK hold	4		4		ns
$t_d(DO-BCLK)$	BCLK to DOUT delay		22		20	ns
$t_s(DI)$	DIN setup	5		5		ns
$t_h(DI)$	DIN hold	5		5		ns
t_r	BCLK Rise time		5		4	ns
t_f	BCLK Fall time		5		4	ns

I²C Interface Timing

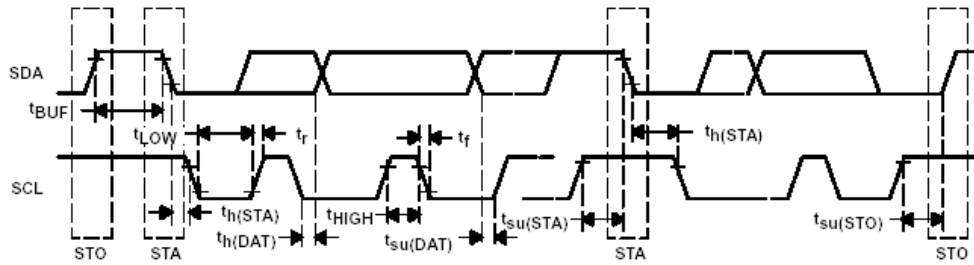

Figure 7. I²C Interface Timing Diagram

Table 6. I²C Interface Timing (see Figure 7)

PARAMETER	TEST CONDITION	Standard-Mode			Fast-Mode			UNITS			
		MIN	TYP	MAX	MIN	TYP	MAX				
f _{SCL}	SCL clock frequency			0		100		0		400	kHz
t _{HD;STA}	Hold time (repeated) START condition. After this period, the first clock pulse is generated.			4.0				0.8			μs
t _{LOW}	LOW period of the SCL clock			4.7				1.3			μs
t _{HIGH}	HIGH period of the SCL clock			4.0				0.6			μs
t _{SU;STA}	Setup time for a repeated START condition			4.7				0.8			μs
t _{HD;DAT}	Data hold time: For I2C bus devices			0		3.45		0		0.9	μs
t _{SU;DAT}	Data set-up time			250				100			ns
t _r	SDA and SCL Rise Time					1000		20 + 0.1C _b		300	ns
t _f	SDA and SCL Fall Time					300		20 + 0.1C _b		300	ns
t _{SU;STO}	Set-up time for STOP condition			4.0				0.8			μs
t _{BUF}	Bus free time between a STOP and START condition			4.7				1.3			μs
C _b	Capacitive load for each bus line					400				400	pF

SPI Interface Timing

SS = SCL pin, **SCLK** = I2C_ADDR_SCLK pin, **MISO** = GPO1 pin, and **MOSI** = SDA pin. Specifications are at 25° C with DVDD = 1.8V.

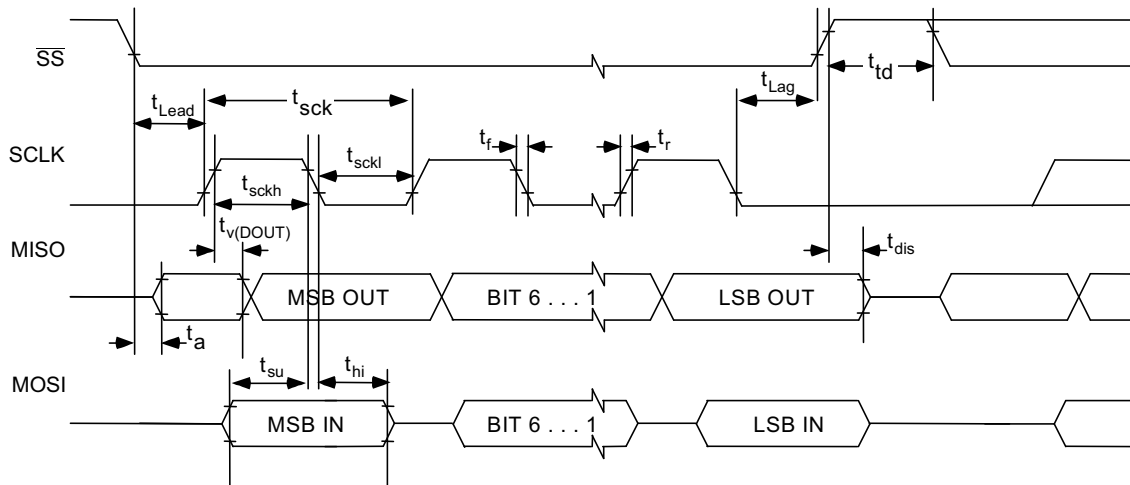

Figure 8. SPI Interface Timing Diagram

Timing Requirements (See Figure 8)

Specifications are at 25° C with DVDD = 1.8 V.

Table 7. SPI Interface Timing

PARAMETER	TEST CONDITION	IOVDD1=1.8V			IOVDD1=3.3V			UNITS
		MIN	TYP	MAX	MIN	TYP	MAX	
t _{sck}	SCLK Period ⁽¹⁾	50			40			ns
t _{sckh}	SCLK Pulse width High	25			20			ns
t _{sckl}	SCLK Pulse width Low	25			20			ns
t _{lead}	Enable Lead Time	25			20			ns
t _{trail}	Enable Trail Time	25			20			ns
t _{d,seqxfr}	Sequential Transfer Delay	25			20			ns
t _a	Slave DOUT (MISO) access time			25			20	ns
t _{dis}	Slave DOUT (MISO) disable time			25			20	ns
t _{su}	DIN (MOSI) data setup time	8			8			ns
t _{h,DIN}	DIN (MOSI) data hold time	8			8			ns
t _{v,DOUT}	DOUT (MISO) data valid time			20			14	ns
t _r	SCLK Rise Time			4			4	ns
t _f	SCLK Fall Time			4			4	ns

(1) These parameters are based on characterization and are not tested in production.

Typical Characteristics

Device Power Consumption

Device power consumption largely depends on PowerTune configuration. For information on device power consumption, see the *TLV320AIC3263 Application Reference Guide*, literature number SLAU475.

Typical Performance

Audio ADC Performance

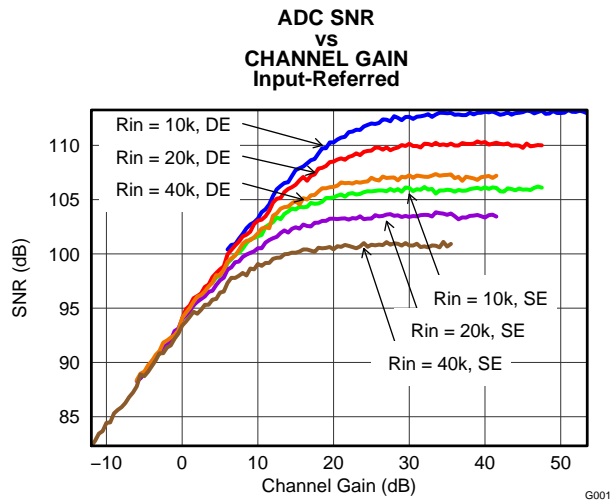

Figure 9.

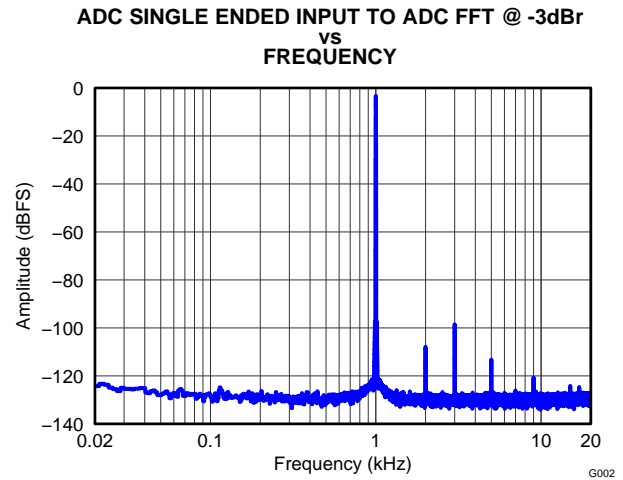

Figure 10.

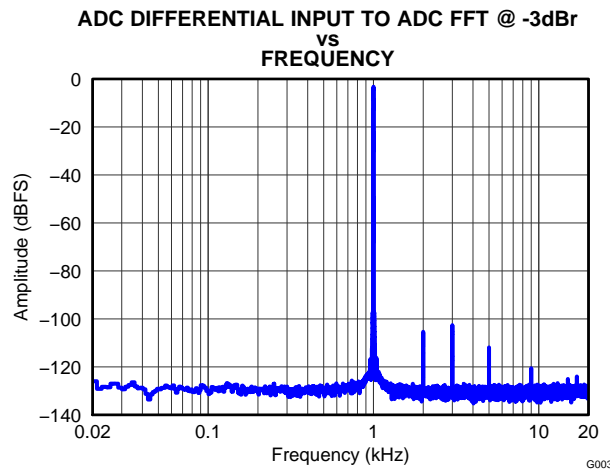

Figure 11.

Audio DAC Performance

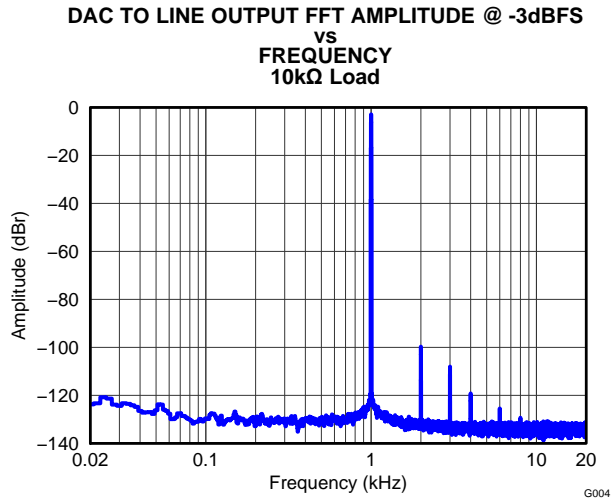

Figure 12.

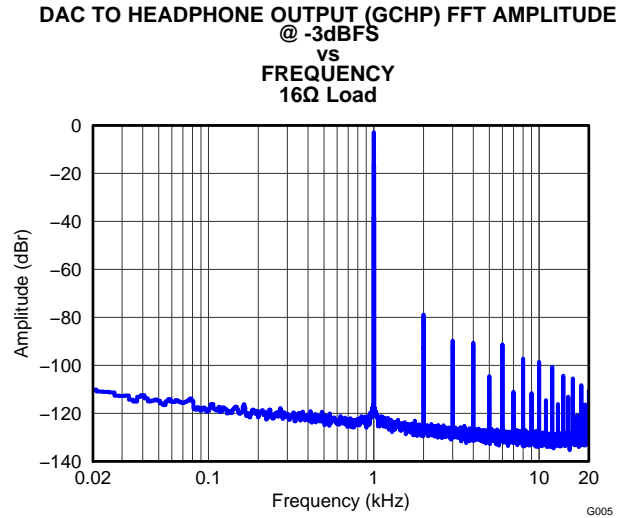

Figure 13.

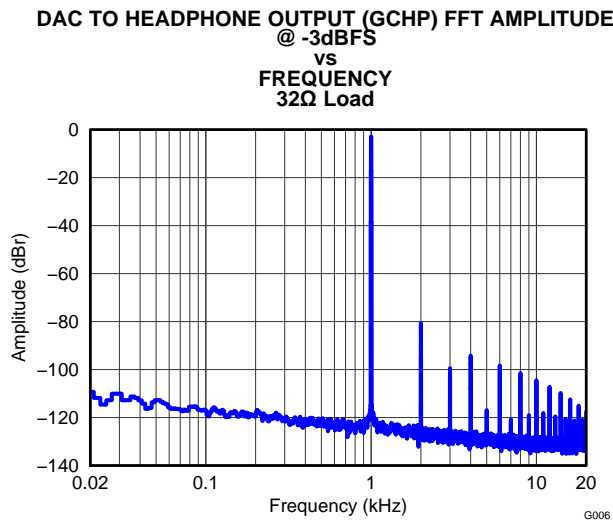

Figure 14.

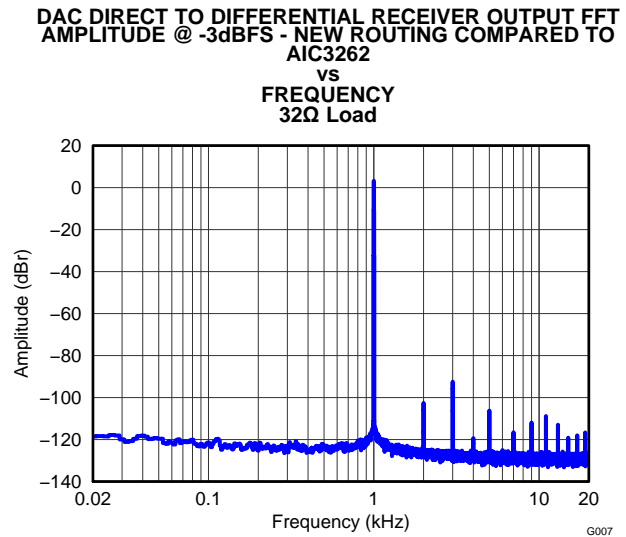

Figure 15.

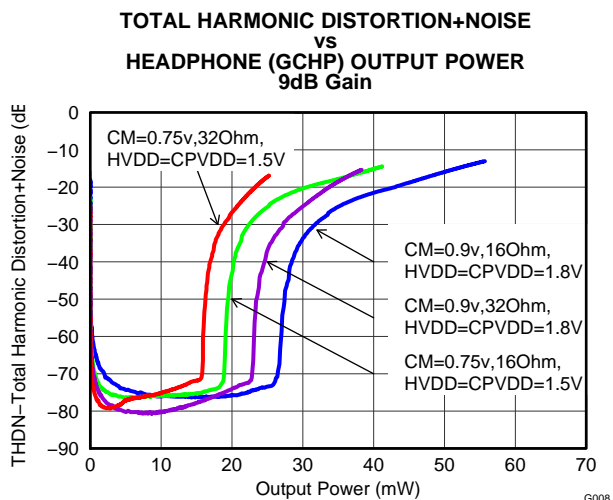

Figure 16.

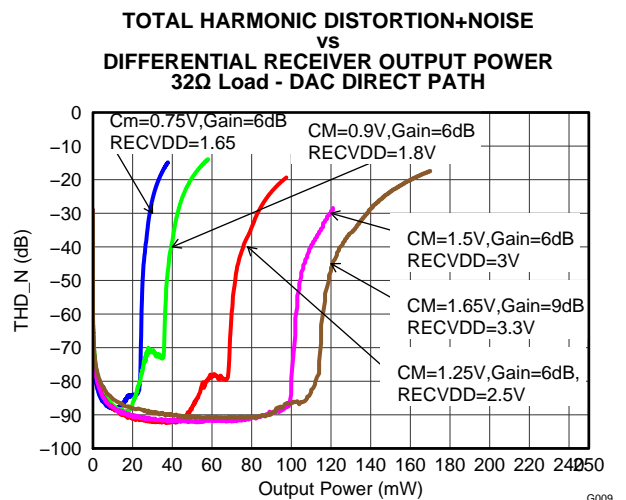

Figure 17.

**DIFFERENTIAL RECEIVER SNR AND OUTPUT POWER (DAC DIRECT PATH)
vs
OUTPUT COMMON MODE SETTING
32Ω Load**

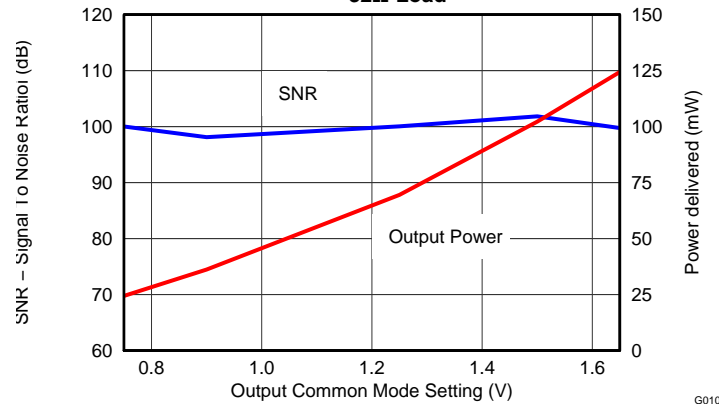

Figure 18.

Class-D Driver Performance

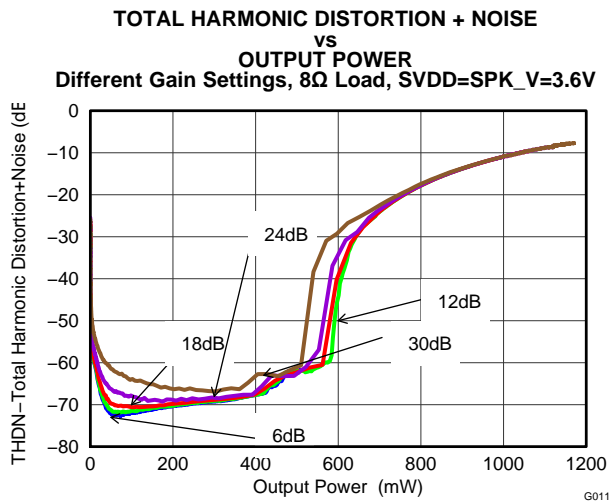

Figure 19.

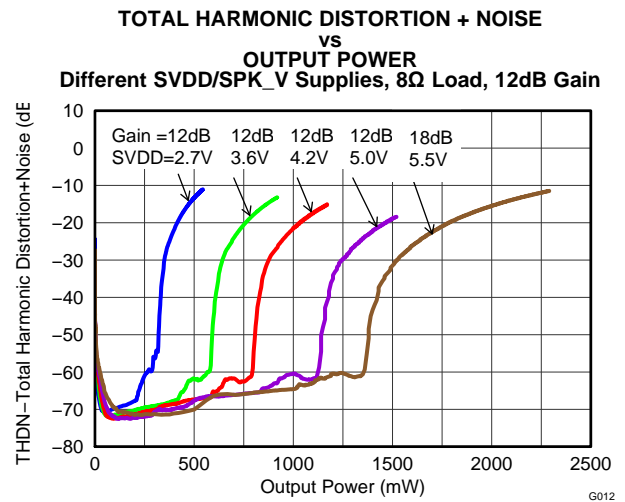

Figure 20.

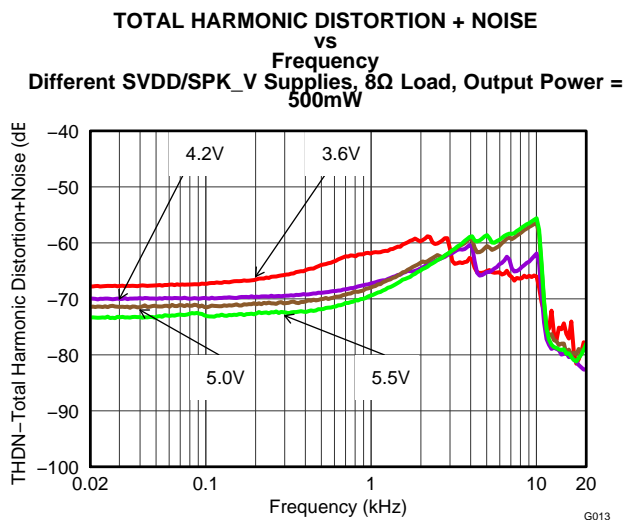

Figure 21.

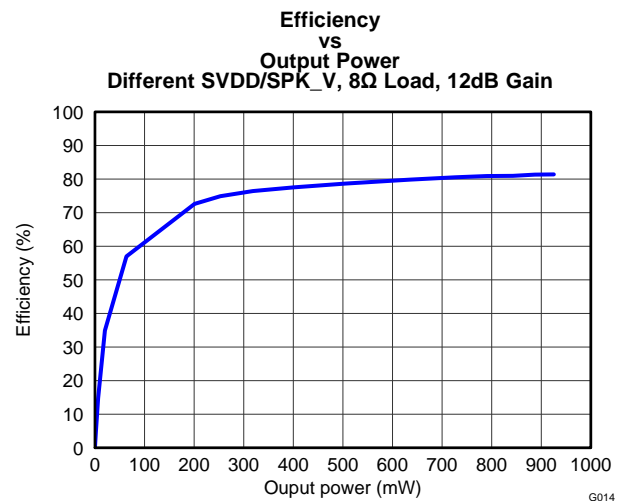

Figure 22.

MICBIAS Performance

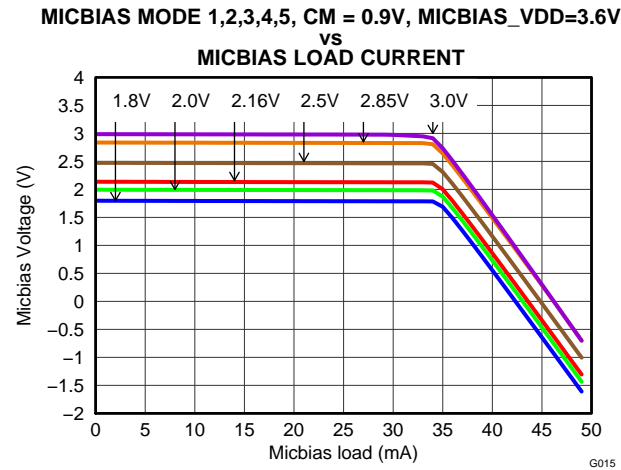

Figure 23.

The fixed-function pins are hardware-control pins $\overline{\text{RESET}}$ and SPI_SELECT pin. Depending on the state of SPI_SELECT, four pins SCL, SDA, GPO1, and I2C_ADDR_SCLK are configured for either I²C or SPI protocol. Only in I²C mode, I2C_ADDR_SCLK provide two possible I²C addresses for the TLV320AIC3263, while this pin receives the SPI SCLK when the device is set to SPI mode.

Other digital IO pins can be configured for various functions via register control.

Analog Pins

Analog functions can also be configured to a large degree. For minimum power consumption, analog blocks are powered down by default. The blocks can be powered up with fine granularity according to the application needs.

The possible analog routings of analog input pins to ADCs and output amplifiers as well as the routing from DACs to output amplifiers can be seen in the Analog Routing Diagram.

Multifunction Pins

Table 8 show the possible allocation of pins for specific functions. The PLL input, for example, can be programmed to be any of 9 pins (MCLK, BCLK1, DIN1, BCLK2, BCLK3, GPIO1, GPIO2, GPIO3, GPIO6).

Table 8. Multifunction Pin Assignments for Pins MCLK, GPIO5, WCLK1, BCLK1, DIN1, DOUT1, WCLK2, BCLK2, DIN2, and DOUT2

		1	2	3	4	5	6	7	8	9	10
	Pin Function	MCLK	GPIO5	WCLK1	BCLK1	DIN1	DOUT1	WCLK2	BCLK2	DIN2	DOUT2
A	INT1 Output						E	E	E		E
B	INT2 Output						E	E	E		E
D	CLOCKOUT Output			E			E	E	E		
E	ADC_MOD_CLOCK Output		E					E	E		E
F	Single DOUT for ASI1 (All Channels)		E				E, D				
F	Single DOUT for ASI2		E								E, D
F	Single DOUT for ASI3		E								
G	Multiple DOUTs for ASI1 (L1, R1)						E				
G	Multiple DOUTs for ASI1 (L2, R2)										E
G	Multiple DOUTs for ASI1 (L3, R3)								E		
G	Multiple DOUTs for ASI1 (L4, R4)							E			
I	General Purpose Output (via Reg)						E ⁽¹⁾	E	E		E
F	Single DIN for ASI1 (All Channels)					E, D ⁽²⁾					
F	Single DIN for ASI2									E, D	
F	Single DIN for ASI3										
H	Multiple DINs for ASI1 (L1, R1)					E					
H	Multiple DINs for ASI1 (L2, R2)									E	
H	Multiple DINs for ASI1 (L3, R3)		E						E		
H	Multiple DINs for ASI1 (L4, R4)		E					E			
J	Digital Mic Data		E			E				E	

(1) E: The pin is **exclusively** used for this function, no other function can be implemented with the same pin (such as if DOUT1 has been allocated for General Purpose Output, it cannot be used as the INT1 output at the same time)

(2) D: Default Function

Table 8. Multifunction Pin Assignments for Pins MCLK, GPIO5, WCLK1, BCLK1, DIN1, DOUT1, WCLK2, BCLK2, DIN2, and DOUT2 (continued)

		1	2	3	4	5	6	7	8	9	10
	Pin Function	MCLK	GPIO5	WCLK1	BCLK1	DIN1	DOUT1	WCLK2	BCLK2	DIN2	DOUT2
K	Input to PLL_CLKIN	S ⁽³⁾ , D			S ⁽⁴⁾	S			S ⁽⁴⁾		
L	Input to ADC_CLKIN	S ⁽³⁾ , D	S		S ⁽⁴⁾				S ⁽⁴⁾		
M	Input to DAC_CLKIN	S ⁽³⁾ , D	S		S ⁽⁴⁾				S ⁽⁴⁾		
N	Input to CDIV_CLKIN	S ⁽³⁾ , D	S		S	S			S		
O	Input to LFR_CLKIN	S ⁽³⁾ , D	S	S				S	S	S	
P	Input to HF_CLK	S ⁽³⁾									
Q	Input to REF_1MHz_CLK	S ⁽³⁾									
R	General Purpose Input (via Reg)		E			E		E	E	E	
S	ISR Interrupt for miniDSP (via Reg)									E	
T	WCLK Output for ASI1			E							
U	WCLK Input for ASI1			S, D							
V	BCLK Output for ASI1				E						
W	BCLK Input for ASI1				S ⁽⁴⁾ , D						
X	WCLK Output for ASI2							E			
Y	WCLK Input for ASI2							S, D			
Z	BCLK Output for ASI2								E		
AA	BCLK Input for ASI2								S ⁽⁴⁾ , D		
BB	WCLK Output for ASI3										
CC	WCLK Input for ASI3										
DD	BCLK Output for ASI3										
EE	BCLK Input for ASI3										

- (3) S⁽³⁾: The MCLK pin could be chosen to drive the PLL, ADC Clock, DAC Clock, CDIV Clock, LFR Clock, HF Clock, and REF_1MHz_CLK inputs **simultaneously**
- (4) S⁽⁴⁾: The BCLK1 or BCLK2 pins could be chosen to drive the PLL, ADC Clock, DAC Clock, and audio interface bit clock inputs **simultaneously**

Table 9. Multifunction Pin Assignments for Pins WCLK3, BCLK3, DIN3, DOUT3, GPIO1, GPIO2, GPO1, I2C_ADDR_SCL, GPIO6, GPIO3, and GPIO4

		11	12	13	14	15	16	17	18	19	20	21
	Pin Function	WCLK3	BCLK3	DIN3	DOUT3	GPIO1	GPIO2	GPO1/ MISO ⁽¹⁾	I2C_ADDR_SCL	GPIO6	GPIO3	GPIO4
A	INT1 Output					E	E	E				
B	INT2 Output					E	E	E				
D	CLOCKOUT Output					E	E	E				
E	ADC_MOD_CLOCK Output				E	E	E	E		E	E	E
F	Single DOUT for ASI1 (All Channels)							E		E		
F	Single DOUT for ASI2											
F	Single DOUT for ASI3				E, D							
G	Multiple DOUTs for ASI1 (L1, R1)											
G	Multiple DOUTs for ASI1 (L2, R2)				E		E	E				
G	Multiple DOUTs for ASI1 (L3, R3)		E		E	E	E	E				

(1) GPO1 can only be utilized for functions defined in this table when part utilizes I²C for control. In SPI mode, this pin serves as MISO.

Table 9. Multifunction Pin Assignments for Pins WCLK3, BCLK3, DIN3, DOUT3, GPIO1, GPIO2, GPIO3, I2C_ADDR_SCL, GPIO6, GPIO3, and GPIO4 (continued)

		11	12	13	14	15	16	17	18	19	20	21
	Pin Function	WCLK3	BCLK3	DIN3	DOUT3	GPIO1	GPIO2	GPO1/ MISO ⁽¹⁾	I2C_ADDR_SCL	GPIO6	GPIO3	GPIO4
G	Multiple DOUTs for ASI1 (L4, R4)	E				E	E	E				
I	General Purpose Output (via Reg)	E ⁽²⁾	E		E	E	E	E				
F	Single DIN for ASI1 (All Channels)									E		
F	Single DIN for ASI2									E		
F	Single DIN for ASI3			E, D						E		
H	Multiple DINs for ASI1 (L1, R1)											
H	Multiple DINs for ASI1 (L2, R2)						E			E	E	
H	Multiple DINs for ASI1 (L3, R3)			E		E	E			E	E	
H	Multiple DINs for ASI1 (L4, R4)					E	E			E	E	
J	Digital Mic Data	E	E	E		E	E			E	E	E
K	Input to PLL_CLKIN		S ⁽³⁾			S ⁽³⁾	S ⁽³⁾			S ⁽³⁾	S ⁽³⁾	
L	Input to ADC_CLKIN		S ⁽³⁾			S ⁽³⁾	S ⁽³⁾			S ⁽³⁾	S ⁽³⁾	
M	Input to DAC_CLKIN		S ⁽³⁾			S ⁽³⁾	S ⁽³⁾			S ⁽³⁾	S ⁽³⁾	
N	Input to CDIV_CLKIN									S	S	
O	Input to LFR_CLKIN	S	S			S	S			S	S	
P	Input to HF_CLK											
Q	Input to REF_1MHz_CLK											
R	General Purpose Input (via Reg)	E	E	E		E	E			E		E
S	ISR Interrupt for miniDSP (via Reg)					E	E				E	
T	WCLK Output for ASI1				E	E						
U	WCLK Input for ASI1					E						
V	BCLK Output for ASI1						E					
W	BCLK Input for ASI1						E					
X	WCLK Output for ASI2					E						
Y	WCLK Input for ASI2					E						
Z	BCLK Output for ASI2						E					
AA	BCLK Input for ASI2						E					
BB	WCLK Output for ASI3	E				E						
CC	WCLK Input for ASI3	S, D ⁽⁴⁾				E						
DD	BCLK Output for ASI3		E				E					
EE	BCLK Input for ASI3		S, D				E					
FF	ADC BCLK Input for ASI1					E	E			E	E	E

(2) E: The pin is **exclusively** used for this function, no other function can be implemented with the same pin (such as if WCLK3 has been allocated for General Purpose Output, it cannot be used as the ASI3 WCLK output at the same time)

(3) S⁽⁴⁾: The GPIO1, GPIO2, GPIO3, or GPIO6 pins could be chosen to drive the PLL, ADC Clock, and DAC Clock inputs **simultaneously**

(4) D: Default Function

Table 9. Multifunction Pin Assignments for Pins WCLK3, BCLK3, DIN3, DOUT3, GPIO1, GPIO2, GPO1, I2C_ADDR_SCL, GPIO6, GPIO3, and GPIO4 (continued)

		11	12	13	14	15	16	17	18	19	20	21
	Pin Function	WCLK3	BCLK3	DIN3	DOUT3	GPIO1	GPIO2	GPO1/ MISO ⁽¹⁾	I2C_ADDR_SCL	GPIO6	GPIO3	GPIO4
GG	ADC WCLK Input for ASI1					E	E			E	E	E
HH	ADC BCLK Output for ASI1					E	E					
II	ADC WCLK Output for ASI1					E	E					
JJ	ADC BCLK Input for ASI2					E	E			E	E	E
KK	ADC WCLK Input for ASI2					E	E			E	E	E
LL	ADC BCLK Output for ASI2					E	E					
MM	ADC WCLK Output for ASI2					E	E					
NN	ADC BCLK Input for ASI3					E	E			E	E	E
OO	ADC WCLK Input for ASI3					E	E			E	E	E
PP	ADC BCLK Output for ASI3					E	E					
QQ	ADC WCLK Output for ASI3					E	E					
RR	Bit Bang Input					E	E			E	E	E
SS	Bit Bang Output					E	E			E	E	E

Analog Audio I/O

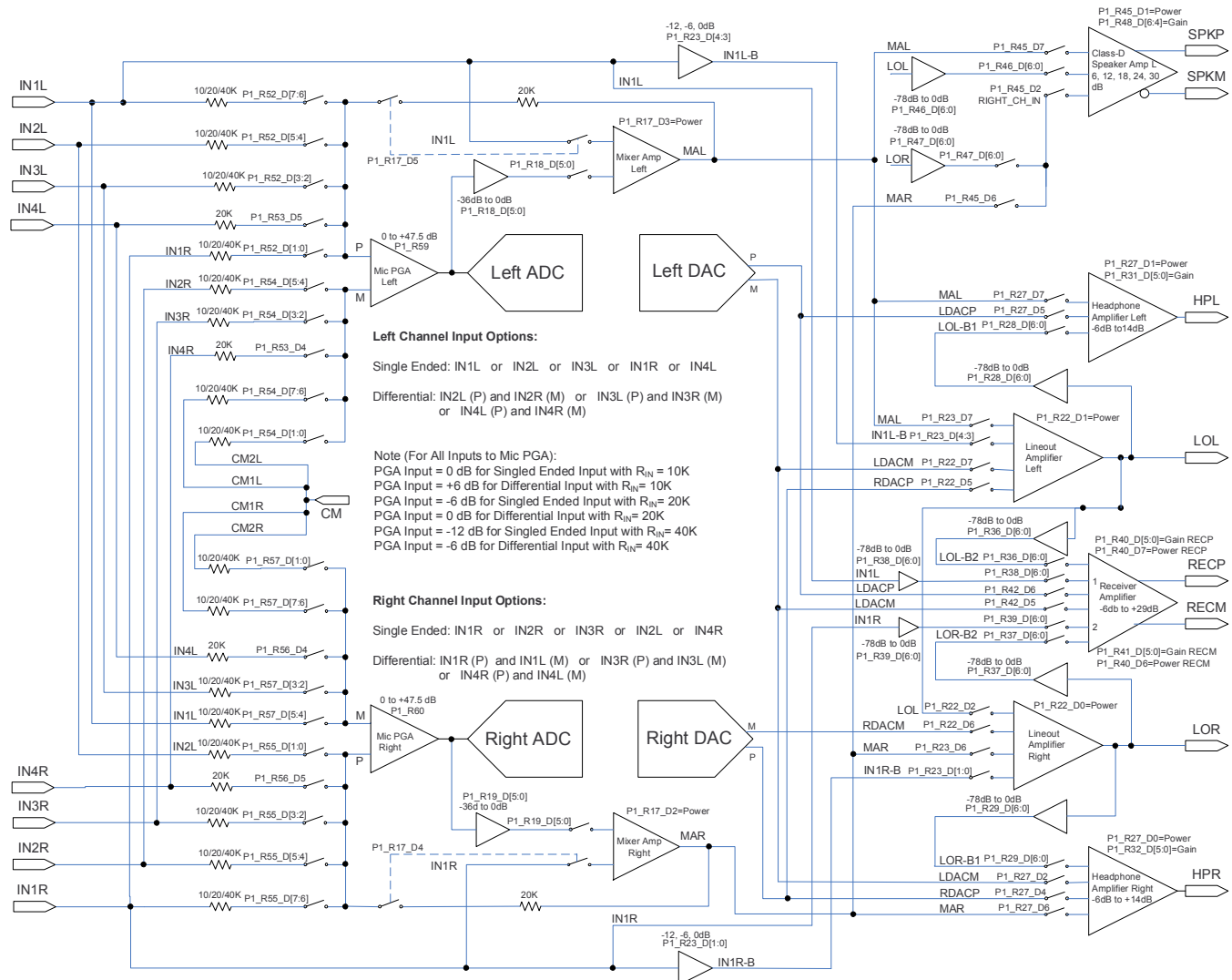

Figure 25. Analog Routing Diagram

For more detailed information see the TLV320AIC3263 Application Reference Guide [SLAU475](#).

Analog Low Power Bypass

The TLV320AIC3263 offers two analog-bypass modes. In either of the modes, an analog input signal can be routed from an analog input pin to an amplifier driving an analog output pin. Neither the ADC nor the DAC resources are required for such operation; this supports low-power operation during analog-bypass mode. In analog low-power bypass mode, line-level signals can be routed directly from the analog inputs IN1L to the left lineout amplifier (LOL) and IN1R to LOR. Additionally, line-level signals can be routed directly from these analog inputs to the amplifier, which outputs on RECP and RECM.

ADC Bypass Using Mixer Amplifiers

In addition to the low-power bypass mode, there is a bypass mode that uses the programmable gain amplifiers of the input stage in conjunction with a mixer amplifier. With this mode, microphone-level signals can be amplified and routed to the line, speaker, or headphone outputs, fully bypassing the ADC and DAC. To enable this mode, the mixer amplifiers are powered on via software command.

Headphone Outputs

The stereo headphone drivers on pins HPL and HPR can drive loads with impedances down to 16Ω in single-ended DC-coupled headphone configurations. An integral charge pump generates the negative supply required to operate the headphone drivers in dc-coupled mode, where the common mode of the output signal is made equal to the ground of the headphone load using a ground-sense circuit. Operation of headphone drivers in dc-coupled (ground centered mode) eliminates the need for large dc-blocking capacitors.

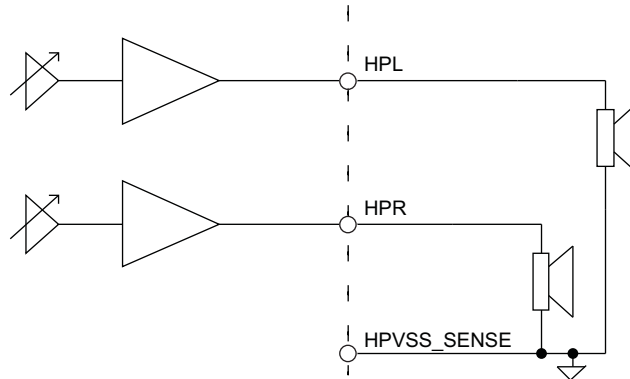

Figure 26. TLV320AIC3263 Ground-Centered Headphone Output

Alternatively the headphone amplifier can also be operated in a unipolar circuit configuration using DC blocking capacitors.

Stereo Line Outputs

The stereo line level drivers on LOL and LOR pins can drive a wide range of line level resistive impedances in the range of 600Ω to $10k\Omega$. The output common mode of line level drivers can be configured to equal the analog input common-mode setting, either $0.75V$ or $0.9V$. The line-level drivers can drive out a mixed combination of DAC signal and attenuated ADC PGA signal, and signal mixing is register-programmable.

Differential Receiver Output

The differential receiver amplifier output spans the RECP and RECM pins and can drive a 32Ω receiver driver. With output common-mode setting of $1.65V$ and RECVDD_33 supply at $3.3V$, the receiver driver can drive up to a $1V_{rms}$ output signal. With the RECVDD_33 supply at $3.3V$, the receiver driver can deliver greater than $128mW$ into a 32Ω BTL load. If desired, the RECVDD_33 supply can be set to $1.8V$, at which the driver can deliver about $40mW$ into the 32Ω BTL load.

Class-D Speaker Output

The integrated Class-D speaker driver (SPKP/SPKN) is capable of driving an 8Ω differential load. The speaker driver can be powered directly from the power supply ($2.7V$ to $5.5V$) on the SVDD pin, however the voltage (including spike voltage) must be limited below the Absolute Maximum Voltage of $6.0V$.

The speaker driver is capable of supplying $720mW$ at 10% THD+N with a $3.6V$ power supply and $1.40W$ at 10% THD+N with a $5.0V$ power supply. Separate left and right channels can be sent to the Class-D driver through the Lineout signal path, or from the mixer amplifiers in the ADC bypass. Additionally, the analog mixer before the Speaker amplifier can sum the left and right audio signals for monophonic playback.

ADC / Digital Microphone Interface

The TLV320AIC3263 includes a stereo audio ADC, which uses a delta-sigma modulator with a programmable oversampling ratio, followed by a digital decimation filter and a programmable miniDSP. The ADC supports sampling rates from $8kHz$ to $192kHz$. In order to provide optimal system power management, the stereo recording path can be powered up one channel at a time, to support the case where only mono record capability is required.

The ADC path of the TLV320AIC3263 features a large set of options for signal conditioning as well as signal routing:

- 2 ADCs
- 8 analog inputs which can be mixed and/or multiplexed in single-ended and/or differential configuration
- 2 programmable gain amplifiers (PGA) with a range of 0 to +47.5dB
- 2 mixer amplifiers for analog bypass
- 2 low power analog bypass channels
- Fine gain adjust of digital channels with 0.1 dB step size
- Digital volume control with a range of -12 to +20dB
- Mute function
- Automatic gain control (AGC)

In addition to the standard set of ADC features the TLV320AIC3263 also offers the following special functions:

- Built in microphone biases
- Four-channel digital microphone interface
 - Allows 4 total microphones
 - Up to 4 digital microphones
 - Up to 2 analog microphones
- Channel-to-channel phase adjustment
- Fast charge of ac-coupling capacitors
- Anti thump
- Adaptive filter mode

ADC Processing Blocks — Overview

The TLV320AIC3263 ADC channel includes a built-in digital decimation filter to process the oversampled data from the to generate digital data at Nyquist sampling rate with high dynamic range. The decimation filter can be chosen from three different types, depending on the required frequency response, group delay and sampling rate.

ADC Processing Blocks

The TLV320AIC3263 offers a range of processing blocks which implement various signal processing capabilities along with decimation filtering. These processing blocks give users the choice of how much and what type of signal processing they may use and which decimation filter is applied.

The choice between these processing blocks is part of the PowerTune strategy to balance power conservation and signal-processing flexibility. Decreasing the use of signal-processing capabilities reduces the power consumed by the device. [Table 10](#) gives an overview of the available processing blocks of the ADC channel and their properties. The Resource Class Column (RC) gives an approximate indication of power consumption.

The signal processing blocks available are:

- First-order IIR
- Scalable number of biquad filters
- Variable-tap FIR filter
- AGC

The processing blocks are tuned for common cases and can achieve high anti-alias filtering or low-group delay in combination with various signal processing effects such as audio effects and frequency shaping. The available first order IIR, BiQuad and FIR filters have fully user programmable coefficients.

Table 10. ADC Processing Blocks

Processing Blocks	Channel	Decimation Filter	1st Order IIR Available	Number BiQuads	FIR	Required AOSR Value	Resource Class
PRB_R1 ⁽¹⁾	Stereo	A	Yes	0	No	128,64,32,16,8,4	7
PRB_R2	Stereo	A	Yes	2	No	128,64,32,16,8,4	8
PRB_R3	Stereo	A	Yes	0	17-Tap	128,64,32,16,8,4	8
PRB_R4	Left	A	Yes	0	No	128,64,32,16,8,4	4
PRB_R5	Left	A	Yes	5	No	128,64,32,16,8,4	5
PRB_R6	Left	A	Yes	0	25-Tap	128,64,32,16,8,4	5
PRB_R7	Stereo	B	Yes	0	No	64,32,16,8,4,2	4
PRB_R8	Stereo	B	Yes	3	No	64,32,16,8,4,2	5
PRB_R9	Stereo	B	Yes	0	17-Tap	64,32,16,8,4,2	5
PRB_R10	Left	B	Yes	0	No	64,32,16,8,4,2	2
PRB_R11	Left	B	Yes	3	No	64,32,16,8,4,2	3
PRB_R12	Left	B	Yes	0	17-Tap	64,32,16,8,4,2	3
PRB_R13	Stereo	C	Yes	0	No	32,16,8,4,2,1	4
PRB_R14	Stereo	C	Yes	5	No	32,16,8,4,2,1	5
PRB_R15	Stereo	C	Yes	0	25-Tap	32,16,8,4,2,1	5
PRB_R16	Left	C	Yes	0	No	32,16,8,4,2,1	2
PRB_R17	Left	C	Yes	5	No	32,16,8,4,2,1	3
PRB_R18	Left	C	Yes	0	25-Tap	32,16,8,4,2,1	3
PRB_R19	Stereo	A	Yes	5	No	128,64,32,16,8,4	9
PRB_R20	Stereo	A	Yes	0	25-Tap	128,64,32,16,8,4	9

(1) Default

For more detailed information see the TLV320AIC3263 Application Reference Guide.

DAC

The TLV320AIC3263 includes a stereo audio DAC supporting data rates from 8kHz to 192kHz. Each channel of the stereo audio DAC consists of a signal-processing engine with fixed processing blocks, a digital interpolation filter, multi-bit digital delta-sigma modulator, and an analog reconstruction filter. The DAC is designed to provide enhanced performance at low sampling rates through increased oversampling and image filtering, thereby keeping quantization noise generated within the delta-sigma modulator and signal images strongly suppressed within the audio band to beyond 20kHz. To handle multiple input rates and optimize power dissipation and performance, the TLV320AIC3263 allows the system designer to program the oversampling rates over a wide range from 1 to 1024. The system designer can choose higher oversampling ratios for lower input data rates and lower oversampling ratios for higher input data rates.

The TLV320AIC3263 DAC channel includes a built-in digital interpolation filter to generate oversampled data for the sigma-delta modulator. The interpolation filter can be chosen from three different types depending on required frequency response, group delay and sampling rate.

The DAC path of the TLV320AIC3263 features many options for signal conditioning and signal routing:

- 2 headphone amplifiers
 - Usable in single-ended stereo or differential mono mode
 - Analog volume setting with a range of -6 to +14 dB
- 2 line-out amplifiers
 - Usable in single-ended stereo or differential mono mode
- Class-D speaker amplifier
 - Usable with left, right, or monophonic mix modes
 - Analog volume control with a settings of +6, +12, +18, +24, and +30 dB
- 1 Receiver amplifier
 - Usable in mono differential mode
 - Analog volume setting with a range of -6 to +29 dB
- Digital volume control with a range of -63.5 to +24dB
- Mute function
- Dynamic range compression (DRC)

In addition to the standard set of DAC features the TLV320AIC3263 also offers the following special features:

- Built in sine wave generation (beep generator)
- Digital auto mute
- Adaptive filter mode
- Asynchronous Sample Rate Conversion

DAC Processing Blocks — Overview

The TLV320AIC3263 implements signal processing capabilities and interpolation filtering via processing blocks. These fixed processing blocks give users the choice of how much and what type of signal processing they may use and which interpolation filter is applied.

The choice between these processing blocks is part of the PowerTune strategy balancing power conservation and signal processing flexibility. Less signal processing capability will result in less power consumed by the device. The [Table 11](#) gives an overview over all available processing blocks of the DAC channel and their properties. The Resource Class Column (RC) gives an approximate indication of power consumption.

The signal processing blocks available are:

- First-order IIR
- Scalable number of biquad filters
- 3D – Effect
- Beep Generator

The processing blocks are tuned for common cases and can achieve high image rejection or low group delay in combination with various signal processing effects such as audio effects and frequency shaping. The available first-order IIR and biquad filters have fully user-programmable coefficients.

Table 11. Overview – DAC Predefined Processing Blocks

Processing Block No.	Interpolation Filter	Channel	1st Order IIR Available	Num. of Biquads	DRC	3D	Beep Generator	RC Class
PRB_P1 ⁽¹⁾	A	Stereo	No	2	No	No	No	8
PRB_P2	A	Stereo	Yes	6	Yes	No	No	12
PRB_P3	A	Stereo	Yes	6	No	No	No	10
PRB_P4	A	Left	No	2	No	No	No	4
PRB_P5	A	Left	Yes	6	Yes	No	No	6
PRB_P6	A	Left	Yes	6	No	No	No	5
PRB_P7	B	Stereo	Yes	0	No	No	No	6
PRB_P8	B	Stereo	No	4	Yes	No	No	8
PRB_P9	B	Stereo	No	4	No	No	No	7
PRB_P10	B	Stereo	Yes	6	Yes	No	No	10
PRB_P11	B	Stereo	Yes	6	No	No	No	8
PRB_P12	B	Left	Yes	0	No	No	No	3
PRB_P13	B	Left	No	4	Yes	No	No	5
PRB_P14	B	Left	No	4	No	No	No	4
PRB_P15	B	Left	Yes	6	Yes	No	No	5
PRB_P16	B	Left	Yes	6	No	No	No	4
PRB_P17	C	Stereo	Yes	0	No	No	No	3
PRB_P18	C	Stereo	Yes	4	Yes	No	No	7
PRB_P19	C	Stereo	Yes	4	No	No	No	5
PRB_P20	C	Left	Yes	0	No	No	No	2
PRB_P21	C	Left	Yes	4	Yes	No	No	4
PRB_P22	C	Left	Yes	4	No	No	No	3
PRB_P23	A	Stereo	No	1	No	Yes	No	8
PRB_P24	A	Stereo	Yes	3	Yes	Yes	No	12
PRB_P25	A	Stereo	Yes	1	Yes	Yes	Yes	12
PRB_P26	D	Stereo	No	0	No	No	No	1
PRB_P27	A	Stereo	Yes	3	Yes	Yes	Yes	13

(1) Default

For more detailed information see the TLV320AIC3263 Application Reference Guide.

PowerTune

The TLV320AIC3263 features PowerTune, a mechanism to balance power-versus-performance trade-offs at the time of device configuration. The device can be tuned to minimize power dissipation, to maximize performance, or to an operating point between the two extremes to best fit the application.

For more detailed information see the TLV320AIC3263 Application Reference Guide.

Clock Generation and PLL

To minimize power consumption, the system ideally provides a master clock that is a suitable integer multiple of the desired sampling frequencies. In such cases, internal dividers can be programmed to set up the required internal clock signals at very low power consumption. For cases where such master clocks are not available, the built-in PLL can be used to generate a clock signal that serves as an internal master clock. In fact, this master clock can also be routed to an output pin and may be used elsewhere in the system. The clock system is flexible enough that it even allows the internal clocks to be derived directly from an external clock source, while the PLL is used to generate some other clock that is only used outside the TLV320AIC3263.

The TLV320AIC3263 supports a wide range of options for generating clocks for the ADC and DAC sections as well as interface and other control blocks. The clocks for ADC and DAC require source reference clocks, and these clocks can be from a single source or from two separate sources. They can be provided on a variety of device pins such as MCLK, BCLK1, BCLK2, BCLK3, or GPIOx pins. The clocks, ADC_CLKIN and DAC_CLKIN, can then be routed through highly-flexible clock dividers to generate the various clocks required for ADC, DAC and the miniDSP sections. In the event that the desired audio or miniDSP clocks cannot be generated from the reference clocks on MCLK, BCLK1, BCLK2, BCLK3, or GPIOx, the codec also provides the option of using the on-chip PLL which supports a wide range of fractional multiplication values to generate the required clocks. The ADC_CLKIN and DAC_CLKIN can then be routed through highly-flexible clock dividers to generate the various clocks required for ADC, DAC and the miniDSP sections.

For more detailed information see the TLV320AIC3263 Application Reference Guide.

Interfaces

Control Interfaces

The TLV320AIC3263 control interface supports SPI or I²C communication protocols. For SPI, the SPI_SELECT pin should be tied high; for I²C, SPI_SELECT should be tied low. It is not recommended to change the state of SPI_SELECT during device operation.

I²C Control

The TLV320AIC3263 supports the I²C control protocol, and will respond by default (I2C_ADDR_SCLK grounded) to the 7-bit I²C address of 0011000. With the one I²C address pin, I2C_ADDR_SCLK, the device can be configured to respond to one of two 7-bit I²C addresses, 0011000 or 0011001. The full 8-bit I²C address can be calculated as:

8-Bit I²C Address = "001100" + I2C_ADDR_SCLK + R/W

Example: to write to the TLV320AIC3263 with I2C_ADDR_SCLK = 1 the 8-Bit I²C Address is "001100" + I2C_ADDR_SCLK + R/W = "00110010" = 0x32

I²C is a two-wire, open-drain interface supporting multiple devices and masters on a single bus. Devices on the I²C bus only drive the bus lines LOW by connecting them to ground; they never drive the bus lines HIGH. Instead, the bus wires are pulled HIGH by pullup resistors, so the bus wires are HIGH when no device is driving them LOW. This way, two devices cannot conflict; if two devices drive the bus simultaneously, there is no driver contention.

SPI Control

In the SPI control mode, the TLV320AIC3263 uses the pins SCL as \overline{SS} , I2C_ADDR_SCLK as SCLK, GPO1 as MISO, SDA as MOSI; a standard SPI port with clock polarity setting of 0 (typical microprocessor SPI control bit CPOL = 0) and clock phase setting of 1 (typical microprocessor SPI control bit CPHA = 1). The SPI port allows full-duplex, synchronous, serial communication between a host processor (the master) and peripheral devices (slaves). The SPI master (in this case, the host processor) generates the synchronizing clock (driven onto SCLK) and initiates transmissions. The SPI slave devices (such as the TLV320AIC3263) depend on a master to start and synchronize transmissions. A transmission begins when initiated by an SPI master. The byte from the SPI master begins shifting in on the slave MOSI pin under the control of the master serial clock (driven onto SCLK). As the byte shifts in on the MOSI pin, a byte shifts out on the MISO pin to the master shift register.

For more detailed information see the TLV320AIC3263 Application Reference Guide.

Digital Audio Interfaces

The TLV320AIC3263 features three digital audio data serial interfaces, or audio buses. These three interfaces can be run simultaneously, thereby enabling reception and transmission of digital audio from/to three separate devices. A common example of this scenario would be individual connections to an application processor, a communication baseband processor, and a Bluetooth chipset. By utilizing the TLV320AIC3263 as the center of the audio processing in a portable audio system, mixing of voice and music audio is greatly simplified. In addition, the miniDSP can be utilized to greatly enhance the portable device experience by providing advanced audio processing to both communication and media audio streams simultaneously. In addition to the three simultaneous digital audio interfaces, a fourth set of digital audio pins can be muxed into Audio Serial Interface 1. In other words, four separate 4-wire digital audio buses can be connected to the TLV320AIC3263, with up to three of these 4-wire buses receiving and sending digital audio data.

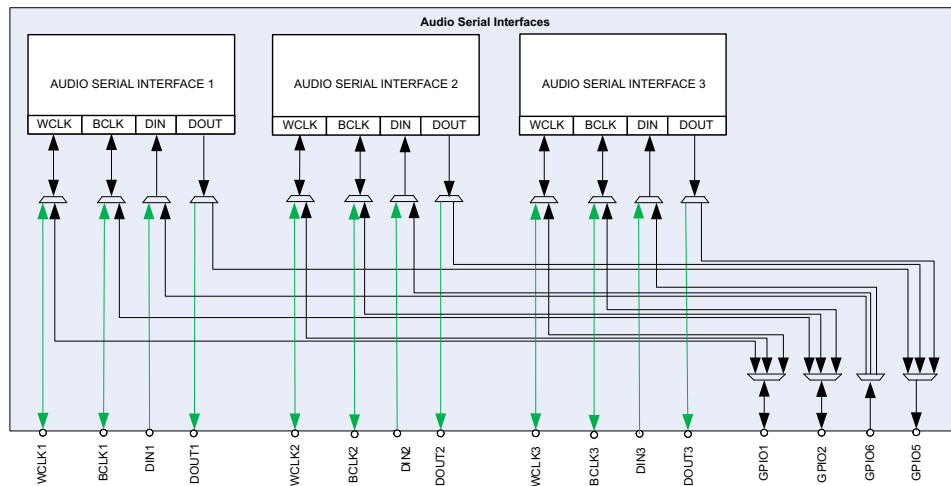

Figure 27. Typical Multiple Connections to Three Audio Serial Interfaces

Each audio bus on the TLV320AIC3263 is very flexible, including left or right-justified data options, support for I²S or PCM protocols, programmable data length options, a TDM mode for multichannel operation, very flexible master/slave configurability for each bus clock line, and the ability to communicate with multiple devices within a system directly.

Each of the three audio buses of the TLV320AIC3263 can be configured for left or right-justified, I²S, DSP, or TDM modes of operation, where communication with PCM interfaces is supported within the TDM mode. These modes are all MSB-first, with data width programmable as 16, 20, 24, or 32 bits. In addition, the word clock and bit clock can be independently configured in either Master or Slave mode, for flexible connectivity to a wide variety of processors. The word clock is used to define the beginning of a frame, and may be programmed as either a pulse or a square-wave signal. The frequency of this clock corresponds to the maximum of the selected ADC and DAC sampling frequencies. When configuring an audio interface for six-wire mode, the ADC and DAC paths can operate based on separate word clocks.

The bit clock is used to clock in and clock out the digital audio data across the serial bus. When in Master mode, this signal can be programmed to generate variable clock pulses by controlling the bit-clock divider. The number of bit-clock pulses in a frame may need adjustment to accommodate various word-lengths as well as to support the case when multiple TLV320AIC3263s may share the same audio bus. When configuring an audio interface for six-wire mode, the ADC and DAC paths can operate based on separate bit clocks.

The TLV320AIC3263 also includes a feature to offset the position of start of data transfer with respect to the word-clock. This offset can be controlled in terms of number of bit-clacks.

The TLV320AIC3263 also has the feature of inverting the polarity of the bit-clock used for transferring the audio data as compared to the default clock polarity used. This feature can be used independently of the mode of audio interface chosen.

The TLV320AIC3263 further includes programmability to 3-state the DOUT line during all bit clocks when valid data is not being sent. By combining this capability with the ability to program at what bit clock in a frame the audio data begins, time-division multiplexing (TDM) can be accomplished, enabling the use of multiple codecs on a single audio serial data bus. When the audio serial data bus is powered down while configured in master mode, the pins associated with the interface are put into a 3-state output condition.

By default, when the word-clocks and bit-clocks are generated by the TLV320AIC3263, these clocks are active only when the codec (ADC, DAC or both) are powered up within the device. This is done to save power. However, it also supports a feature when both the word clocks and bit-clocks can be active even when the codec is powered down. This is useful when using the TDM mode with multiple codecs on the same bus, or when word-clock or bit-clocks are used in the system as general-purpose clocks.

For more detailed information see the TLV320AIC3263 Application Reference Guide.

miniDSP

The TLV320AIC3263 features two fully programmable miniDSP cores. The first miniDSP core is tightly coupled to the ADC, the second miniDSP core is tightly coupled to the DAC. The algorithms for the miniDSP must be loaded into the device after power up. The miniDSPs have direct access to the digital stereo audio stream on the ADC and on the DAC side, offering the possibility for advanced, very-low group delay DSP algorithms. Each miniDSP can run up to 1145 instructions on every audio sample at a 48kHz sample rate. The two cores can run fully synchronized and can exchange data. The TLV320AIC3263 features the ability to process a multitude of algorithms simultaneously. For example, the miniDSPs enable simultaneous noise cancellation, acoustic echo cancellation, sidetone, equalization filtering, dynamic range compression, conversation recording, user-interface sound mixing, and other voice enhancement processing at voice-band sampling rates (such as 8kHz) and high-definition voice sampling rates (such as 16kHz). The TLV320AIC3263 miniDSPs also enable advanced DSP sound enhancement algorithms for an enhanced media experience on a portable audio device.

Software

Software development for the TLV320AIC3263 is supported through TI's comprehensive PurePath Studio Development Environment. A powerful, easy-to-use tool designed specifically to simplify software development on the TLV320AIC3xxx miniDSP audio platform. The Graphical Development Environment consists of a library of common audio functions that can be dragged-and-dropped into an audio signal flow and graphically connected together. The DSP code can then be assembled from the graphical signal flow with the click of a mouse.

For more detailed information see the TLV320AIC3263 Application Reference Guide.

Asynchronous Sample Rate Conversion (ASRC)

For playing back audio/speech signals at various sampling rates, AIC3263 provides an efficient asynchronous sampling rate conversion with the combination of a dedicated ASRC coefficient calculator and the DAC miniDSP engine. The coefficient calculator estimates the audio/speech data input rate versus the DAC playback rate and feeds the calculated coefficients to the miniDSP, with which it converts the audio/speech data to the DAC playback rate. The whole process can be configured automatically without the need of any input sampling rate related information. The input sampling rates as well as the DAC playback rate are not limited to the typical audio/speech sampling rates. A reliable and efficient handshaking is involved between the .

For more detailed information see the TLV320AIC3263 Application Reference Guide.

Power Supply

The TLV320AIC3263 integrates a large amount of digital and analog functionality, and each of these blocks can be powered separately to enable the system to select appropriate power supplies for desired performance and power consumption. The device has separate power domains for digital IO (including three separate digital IO supplies for three separate IOVDD domains), digital core, analog core, analog input, receiver driver, charge-pump input, headphone driver, and speaker driver. If desired, all of the supplies (except for the battery-direct supply for speaker driver and microphone bias) can be connected together and be supplied from one source in the range of 1.65 to 1.95V. Individually, each of the three IOVDD voltages can be supplied in the range of 1.1V to 3.6V. For improved power efficiency, the digital core power supply can range from 1.26V to 1.95V. The analog core voltages (AVDD1_18, AVDD2_18, AVDD4_18, and AVDD_18) can range from 1.5V to 1.95V. The receiver driver supply (RECVDD_33) voltages can range from 1.65V to 3.6V. The charge-pump input voltage (CPVDD_18) can range from 1.26V to 1.95V, and the headphone driver supply (HVDD_18) voltage can range from 1.5V to 1.95V. The speaker driver voltage (SVDD and SPK_V) and microphone bias voltage (MICBIAS_VDD, which is then internally filtered for optimal performance) can range from 2.7V to 5.5V.

For more detailed information see the TLV320AIC3263 Application Reference Guide.

Device Special Functions

The following special functions are available to support advanced system requirements:

- SAR ADC
- Headset detection
- Interrupt generation
- Flexible pin multiplexing

For more detailed information see the TLV320AIC3263 Application Reference Guide.

Register Map Summary

Table 12. Summary of Register Map

Decimal			Hex			DESCRIPTION
BOOK NO.	PAGE NO.	REG. NO.	BOOK NO.	PAGE NO.	REG. NO.	
0	0	0	0x00	0x00	0x00	Page Select Register
0	0	1	0x00	0x00	0x01	Software Reset Register
0	0	2-3	0x00	0x00	0x02-0x03	Reserved Registers
0	0	4	0x00	0x00	0x04	Clock Control Register 1, Clock Input Multiplexers
0	0	5	0x00	0x00	0x05	Clock Control Register 2, PLL Input Multiplexer
0	0	6	0x00	0x00	0x06	Clock Control Register 3, PLL P and R Values
0	0	7	0x00	0x00	0x07	Clock Control Register 4, PLL J Value
0	0	8	0x00	0x00	0x08	Clock Control Register 5, PLL D Values (MSB)
0	0	9	0x00	0x00	0x09	Clock Control Register 6, PLL D Values (LSB)
0	0	10	0x00	0x00	0x0A	Clock Control Register 7, PLL_CLKIN Divider
0	0	11	0x00	0x00	0x0B	Clock Control Register 8, NDAC Divider Values
0	0	12	0x00	0x00	0x0C	Clock Control Register 9, MDAC Divider Values
0	0	13	0x00	0x00	0x0D	DAC OSR Control Register 1, MSB Value
0	0	14	0x00	0x00	0x0E	DAC OSR Control Register 2, LSB Value
0	0	15-17	0x00	0x00	0x0F-0x11	Reserved Registers
0	0	18	0x00	0x00	0x12	Clock Control Register 10, NADC Values
0	0	19	0x00	0x00	0x13	Clock Control Register 11, MADC Values
0	0	20	0x00	0x00	0x14	ADC Oversampling (AOSR) Register
0	0	21	0x00	0x00	0x15	CLKOUT MUX
0	0	22	0x00	0x00	0x16	Clock Control Register 12, CLKOUT M Divider Value
0	0	23	0x00	0x00	0x17	Timer clock
0	0	24	0x00	0x00	0x18	Low Frequency Clock Generation Control
0	0	25	0x00	0x00	0x19	High Frequency Clock Generation Control 1
0	0	26	0x00	0x00	0x1A	High Frequency Clock Generation Control 2
0	0	27	0x00	0x00	0x1B	High Frequency Clock Generation Control 3
0	0	28	0x00	0x00	0x1C	High Frequency Clock Generation Control 4
0	0	29	0x00	0x00	0x1D	High Frequency Clock Trim Control 1
0	0	30	0x00	0x00	0x1E	High Frequency Clock Trim Control 2
0	0	31	0x00	0x00	0x1F	High Frequency Clock Trim Control 3
0	0	32	0x00	0x00	0x20	High Frequency Clock Trim Control 4
0	0	33-35	0x00	0x00	0x21-0x23	Reserved Registers
0	0	36	0x00	0x00	0x24	ADC Flag Register
0	0	37	0x00	0x00	0x25	DAC Flag Register
0	0	38	0x00	0x00	0x26	DAC Flag Register
0	0	39-41	0x00	0x00	0x27-0x29	Reserved Registers
0	0	42	0x00	0x00	0x2A	Sticky Flag Register 1
0	0	43	0x00	0x00	0x2B	Interrupt Flag Register 1
0	0	44	0x00	0x00	0x2C	Sticky Flag Register 2
0	0	45	0x00	0x00	0x2D	Sticky Flag Register 3
0	0	46	0x00	0x00	0x2E	Interrupt Flag Register 2
0	0	47	0x00	0x00	0x2F	Interrupt Flag Register 3

Table 12. Summary of Register Map (continued)

Decimal			Hex			DESCRIPTION
BOOK NO.	PAGE NO.	REG. NO.	BOOK NO.	PAGE NO.	REG. NO.	
0	0	48	0x00	0x00	0x30	INT1 Interrupt Control
0	0	49	0x00	0x00	0x31	INT2 Interrupt Control
0	0	50	0x00	0x00	0x32	SAR Control 1
0	0	51	0x00	0x00	0x33	Interrupt Format Control Register
0	0	52-59	0x00	0x00	0x34-0x3B	Reserved Registers
0	0	60	0x00	0x00	0x3C	DAC Processing Block and miniDSP Power Control
0	0	61	0x00	0x00	0x3D	ADC Processing Block Control
0	0	62	0x00	0x00	0x3E	Reserved Register
0	0	63	0x00	0x00	0x3F	Primary DAC Power and Soft-Stepping Control
0	0	64	0x00	0x00	0x40	Primary DAC Master Volume Configuration
0	0	65	0x00	0x00	0x41	Primary DAC Left Volume Control Setting
0	0	66	0x00	0x00	0x42	Primary DAC Right Volume Control Setting
0	0	67	0x00	0x00	0x43	Headset Detection
0	0	68	0x00	0x00	0x44	DRC Control Register 1
0	0	69	0x00	0x00	0x45	DRC Control Register 2
0	0	70	0x00	0x00	0x46	DRC Control Register 3
0	0	71	0x00	0x00	0x47	Beep Generator Register 1
0	0	72	0x00	0x00	0x48	Beep Generator Register 2
0	0	73	0x00	0x00	0x49	Beep Generator Register 3
0	0	74	0x00	0x00	0x4A	Beep Generator Register 4
0	0	75	0x00	0x00	0x4B	Beep Generator Register 5
0	0	76	0x00	0x00	0x4C	Beep Sin(x) MSB
0	0	77	0x00	0x00	0x4D	Beep Sin(x) LSB
0	0	78	0x00	0x00	0x4E	Beep Cos(x) MSB
0	0	79	0x00	0x00	0x4F	Beep Cos(x) LSB
0	0	80	0x00	0x00	0x50	Reserved Register
0	0	81	0x00	0x00	0x51	ADC Channel Power Control
0	0	82	0x00	0x00	0x52	ADC Fine Gain Volume Control
0	0	83	0x00	0x00	0x53	Left ADC Volume Control
0	0	84	0x00	0x00	0x54	Right ADC Volume Control
0	0	85	0x00	0x00	0x55	ADC Phase Control
0	0	86	0x00	0x00	0x56	Left AGC Control 1
0	0	87	0x00	0x00	0x57	Left AGC Control 2
0	0	88	0x00	0x00	0x58	Left AGC Control 3
0	0	89	0x00	0x00	0x59	Left AGC Attack Time
0	0	90	0x00	0x00	0x5A	Left AGC Decay Time
0	0	91	0x00	0x00	0x5B	Left AGC Noise Debounce
0	0	92	0x00	0x00	0x5C	Left AGC Signal Debounce
0	0	93	0x00	0x00	0x5D	Left AGC Gain
0	0	94	0x00	0x00	0x5E	Right AGC Control 1
0	0	95	0x00	0x00	0x5F	Right AGC Control 2
0	0	96	0x00	0x00	0x60	Right AGC Control 3
0	0	97	0x00	0x00	0x61	Right AGC Attack Time
0	0	98	0x00	0x00	0x62	Right AGC Decay Time
0	0	99	0x00	0x00	0x63	Right AGC Noise Debounce

Table 12. Summary of Register Map (continued)

Decimal			Hex			DESCRIPTION
BOOK NO.	PAGE NO.	REG. NO.	BOOK NO.	PAGE NO.	REG. NO.	
0	0	100	0x00	0x00	0x64	Right AGC Signal Debounce
0	0	101	0x00	0x00	0x65	Right AGC Gain
0	0	102	0x00	0x00	0x66	ADC DC Measurement Control Register 1
0	0	103	0x00	0x00	0x67	ADC DC Measurement Control Register 2
0	0	104	0x00	0x00	0x68	Left Channel DC Measurement Output Register 1 (MSB Byte)
0	0	105	0x00	0x00	0x69	Left Channel DC Measurement Output Register 2 (Middle Byte)
0	0	106	0x00	0x00	0x6A	Left Channel DC Measurement Output Register 3 (LSB Byte)
0	0	107	0x00	0x00	0x6B	Right Channel DC Measurement Output Register 1 (MSB Byte)
0	0	108	0x00	0x00	0x6C	Right Channel DC Measurement Output Register 2 (Middle Byte)
0	0	109	0x00	0x00	0x6D	Right Channel DC Measurement Output Register 3 (LSB Byte)
0	0	110-111	0x00	0x00	0x6E-0x6F	Reserved Registers
0	0	112	0x00	0x00	0x70	Digital Microphone 2 Control
0	0	113-114	0x00	0x00	0x71-0x72	Reserved Registers
0	0	115	0x00	0x00	0x73	I2C Interface Miscellaneous Control
0	0	116-118	0x00	0x00	0x74-0x76	Reserved Registers
0	0	119	0x00	0x00	0x77	miniDSP Control Register 1, Register Access Control
0	0	120	0x00	0x00	0x78	miniDSP Control Register 2, Register Access Control
0	0	121	0x00	0x00	0x79	miniDSP Control Register 3, Register Access Control
0	0	122-126	0x00	0x00	0x7A-0x7E	Reserved Registers
0	0	127	0x00	0x00	0x7F	Book Selection Register
0	1	0	0x00	0x01	0x00	Page Select Register
0	1	1	0x00	0x01	0x01	Power Configuration Register
0	1	2	0x00	0x01	0x02	Reserved Register
0	1	3	0x00	0x01	0x03	Left DAC PowerTune Configuration Register
0	1	4	0x00	0x01	0x04	Right DAC PowerTune Configuration Register
0	1	5-7	0x00	0x01	0x05-0x07	Reserved Registers
0	1	8	0x00	0x01	0x08	Common Mode Register
0	1	9	0x00	0x01	0x09	Headphone Output Driver Control
0	1	10	0x00	0x01	0x0A	Receiver Output Driver Control
0	1	11	0x00	0x01	0x0B	Headphone Output Driver De-pop Control
0	1	12	0x00	0x01	0x0C	Receiver Output Driver De-Pop Control
0	1	13-16	0x00	0x01	0x0D-0x10	Reserved Registers
0	1	17	0x00	0x01	0x11	Mixer Amplifier Control
0	1	18	0x00	0x01	0x12	Left ADC PGA to Left Mixer Amplifier (MAL) Volume Control
0	1	19	0x00	0x01	0x13	Right ADC PGA to Right Mixer Amplifier (MAR) Volume Control
0	1	20-21	0x00	0x01	0x14-0x15	Reserved Registers
0	1	22	0x00	0x01	0x16	Lineout Amplifier Control 1
0	1	23	0x00	0x01	0x17	Lineout Amplifier Control 2
0	1	24-26	0x00	0x01	0x18-0x1A	Reserved
0	1	27	0x00	0x01	0x1B	Headphone Amplifier Control 1

Table 12. Summary of Register Map (continued)

Decimal			Hex			DESCRIPTION
BOOK NO.	PAGE NO.	REG. NO.	BOOK NO.	PAGE NO.	REG. NO.	
0	1	28	0x00	0x01	0x1C	Headphone Amplifier Control 2
0	1	29	0x00	0x01	0x1D	Headphone Amplifier Control 3
0	1	30	0x00	0x01	0x1E	Reserved Register
0	1	31	0x00	0x01	0x1F	HPL Driver Volume Control
0	1	32	0x00	0x01	0x20	HPR Driver Volume Control
0	1	33	0x00	0x01	0x21	Charge Pump Control 1
0	1	34	0x00	0x01	0x22	Charge Pump Control 2
0	1	35	0x00	0x01	0x23	Charge Pump Control 3
0	1	36	0x00	0x01	0x24	Receiver Amplifier Control 1
0	1	37	0x00	0x01	0x25	Receiver Amplifier Control 2
0	1	38	0x00	0x01	0x26	Receiver Amplifier Control 3
0	1	39	0x00	0x01	0x27	Receiver Amplifier Control 4
0	1	40	0x00	0x01	0x28	Receiver Amplifier Control 5
0	1	41	0x00	0x01	0x29	Receiver Amplifier Control 6
0	1	42	0x00	0x01	0x2A	Receiver Amplifier Control 7
0	1	43-44	0x00	0x01	0x2B-0x2C	Reserved Registers
0	1	45	0x00	0x01	0x2D	Speaker Amplifier Control 1
0	1	46	0x00	0x01	0x2E	Speaker Amplifier Control 2
0	1	47	0x00	0x01	0x2F	Speaker Amplifier Control 3
0	1	48	0x00	0x01	0x30	Speaker Amplifier Volume Controls
0	1	49-50	0x00	0x01	0x31-0x32	Reserved Registers
0	1	51	0x00	0x01	0x33	Microphone Bias Control
0	1	52	0x00	0x01	0x34	Input Select 1 for Left Microphone PGA P-Terminal
0	1	53	0x00	0x01	0x35	Input Select 2 for Left Microphone PGA P-Terminal
0	1	54	0x00	0x01	0x36	Input Select for Left Microphone PGA M-Terminal
0	1	55	0x00	0x01	0x37	Input Select 1 for Right Microphone PGA P-Terminal
0	1	56	0x00	0x01	0x38	Input Select 2 for Right Microphone PGA P-Terminal
0	1	57	0x00	0x01	0x39	Input Select for Right Microphone PGA M-Terminal
0	1	58	0x00	0x01	0x3A	Input Common Mode Control
0	1	59	0x00	0x01	0x3B	Left Microphone PGA Control
0	1	60	0x00	0x01	0x3C	Right Microphone PGA Control
0	1	61	0x00	0x01	0x3D	ADC PowerTune Configuration Register
0	1	62	0x00	0x01	0x3E	ADC Analog PGA Gain Flag Register
0	1	63	0x00	0x01	0x3F	DAC Analog Gain Flags Register 1
0	1	64	0x00	0x01	0x40	DAC Analog Gain Flags Register 2
0	1	65	0x00	0x01	0x41	Analog Bypass Gain Flags Register
0	1	66	0x00	0x01	0x42	Driver Power-Up Flags Register
0	1	67-118	0x00	0x01	0x43-0x76	Reserved Registers
0	1	119	0x00	0x01	0x77	Headset Detection Tuning Register 1
0	1	120	0x00	0x01	0x78	Headset Detection Tuning Register 2
0	1	121	0x00	0x01	0x79	Microphone PGA Power-Up Control Register
0	1	122	0x00	0x01	0x7A	Reference Powerup Delay Register
0	1	123-127	0x00	0x01	0x7B-0x7F	Reserved Registers

Table 12. Summary of Register Map (continued)

Decimal			Hex			DESCRIPTION
BOOK NO.	PAGE NO.	REG. NO.	BOOK NO.	PAGE NO.	REG. NO.	
0	3	0	0x00	0x03	0x00	Page Select Register
0	3	1	0x00	0x03	0x01	Reserved Register
0	3	2	0x00	0x03	0x02	Primary SAR ADC Control
0	3	3	0x00	0x03	0x03	Primary SAR ADC Conversion Mode
0	3	4-5	0x00	0x03	0x04-0x05	Reserved Registers
0	3	6	0x00	0x03	0x06	SAR Reference Control
0	3	7-8	0x00	0x03	0x07-0x08	Reserved Registers
0	3	9	0x00	0x03	0x09	SAR ADC Flags Register 1
0	3	10	0x00	0x03	0x0A	SAR ADC Flags Register 2
0	3	11-12	0x00	0x03	0x0B-0x0C	Reserved Registers
0	3	13	0x00	0x03	0x0D	SAR ADC Buffer Mode Control
0	3	14	0x00	0x03	0x0E	Reserved Register
0	3	15	0x00	0x03	0x0F	Scan Mode Timer Control
0	3	16	0x00	0x03	0x10	Reserved Register
0	3	17	0x00	0x03	0x11	SAR ADC Clock Control
0	3	18	0x00	0x03	0x12	SAR ADC Buffer Mode Data Read Control
0	3	19	0x00	0x03	0x13	SAR ADC Measurement Control
0	3	20	0x00	0x03	0x14	Reserved Register
0	3	21	0x00	0x03	0x15	SAR ADC Measurement Threshold Flags
0	3	22	0x00	0x03	0x16	IN1L Max Threshold Check Control 1
0	3	23	0x00	0x03	0x17	IN1L Max Threshold Check Control 2
0	3	24	0x00	0x03	0x18	IN1L Min Threshold Check Control 1
0	3	25	0x00	0x03	0x19	IN1L Min Threshold Check Control 2
0	3	26	0x00	0x03	0x1A	IN1R Max Threshold Check Control 1
0	3	27	0x00	0x03	0x1B	IN1R Max Threshold Check Control 2
0	3	28	0x00	0x03	0x1C	IN1R Min Threshold Check Control 1
0	3	29	0x00	0x03	0x1D	IN1R Min Threshold Check Control 2
0	3	30	0x00	0x03	0x1E	TEMP Max Threshold Check Control 1
0	3	31	0x00	0x03	0x1F	TEMP Max Threshold Check Control 2
0	3	32	0x00	0x03	0x20	TEMP Min Threshold Check Control 1
0	3	33	0x00	0x03	0x21	TEMP Min Threshold Check Control 2
0	3	34-53	0x00	0x03	0x22-0x35	Reserved Registers
0	3	54	0x00	0x03	0x36	IN1L Measurement Data (MSB)
0	3	55	0x00	0x03	0x37	IN1L Measurement Data (LSB)
0	3	56	0x00	0x03	0x38	IN1R Measurement Data (MSB)
0	3	57	0x00	0x03	0x39	IN1R Measurement Data (LSB)
0	3	58	0x00	0x03	0x3A	VBAT Measurement Data (MSB)
0	3	59	0x00	0x03	0x3B	VBAT Measurement Data (LSB)
0	3	60-65	0x00	0x03	0x3C-0x41	Reserved Registers
0	3	66	0x00	0x03	0x42	TEMP1 Measurement Data (MSB)
0	3	67	0x00	0x03	0x43	TEMP1 Measurement Data (LSB)
0	3	68	0x00	0x03	0x44	TEMP2 Measurement Data (MSB)

Table 12. Summary of Register Map (continued)

Decimal			Hex			DESCRIPTION
BOOK NO.	PAGE NO.	REG. NO.	BOOK NO.	PAGE NO.	REG. NO.	
0	3	69	0x00	0x03	0x45	TEMP2 Measurement Data (LSB)
0	3	70-127	0x00	0x03	0x46-0x7F	Reserved Registers
0	4	0	0x00	0x04	0x00	Page Select Register
0	4	1	0x00	0x04	0x01	Audio Serial Interface 1, Audio Bus Format Control Register
0	4	2	0x00	0x04	0x02	Audio Serial Interface 1, Left Ch_Offset_1 Control Register
0	4	3	0x00	0x04	0x03	Audio Serial Interface 1, Right Ch_Offset_2 Control Register
0	4	4	0x00	0x04	0x04	Audio Serial Interface 1, Channel Setup Register
0	4	5	0x00	0x04	0x05	Audio Serial Interface 1, ADC Audio Bus Format Control Register
0	4	6	0x00	0x04	0x06	Audio Serial Interface 1, Multi-Channel Setup Register 2
0	4	7	0x00	0x04	0x07	Audio Serial Interface 1, ADC Input Control
0	4	8	0x00	0x04	0x08	Audio Serial Interface 1, DAC Output Control
0	4	9	0x00	0x04	0x09	Audio Serial Interface 1, Control Register 9, ADC Slot Tristate Control
0	4	10	0x00	0x04	0x0A	Audio Serial Interface 1, WCLK and BCLK Control Register
0	4	11	0x00	0x04	0x0B	Audio Serial Interface 1, Bit Clock N Divider Input Control
0	4	12	0x00	0x04	0x0C	Audio Serial Interface 1, Bit Clock N Divider
0	4	13	0x00	0x04	0x0D	Audio Serial Interface 1, Word Clock N Divider
0	4	14	0x00	0x04	0x0E	Audio Serial Interface 1, BCLK and WCLK Output
0	4	15	0x00	0x04	0x0F	Audio Serial Interface 1, Data Output
0	4	16	0x00	0x04	0x10	Audio Serial Interface 1, ADC WCLK and BCLK Control
0	4	17	0x00	0x04	0x11	Audio Serial Interface 2, Audio Bus Format Control Register
0	4	18	0x00	0x04	0x12	Audio Serial Interface 2, Data Offset Control Register
0	4	19-20	0x00	0x04	0x13-0x14	Reserved Registers
0	4	21	0x00	0x04	0x15	Audio Serial Interface 2, ADC Audio Bus Format Control Register
0	4	22	0x00	0x04	0x16	Reserved Register
0	4	23	0x00	0x04	0x17	Audio Serial Interface 2, ADC Input Control
0	4	24	0x00	0x04	0x18	Audio Serial Interface 2, DAC Output Control
0	4	25	0x00	0x04	0x19	Reserved Register
0	4	26	0x00	0x04	0x1A	Audio Serial Interface 2, WCLK and BCLK Control Register
0	4	27	0x00	0x04	0x1B	Audio Serial Interface 2, Bit Clock N Divider Input Control
0	4	28	0x00	0x04	0x1C	Audio Serial Interface 2, Bit Clock N Divider
0	4	29	0x00	0x04	0x1D	Audio Serial Interface 2, Word Clock N Divider
0	4	30	0x00	0x04	0x1E	Audio Serial Interface 2, BCLK and WCLK Output
0	4	31	0x00	0x04	0x1F	Audio Serial Interface 2, Data Output
0	4	32	0x00	0x04	0x20	Audio Serial Interface 2, ADC WCLK and BCLK Control
0	4	33	0x00	0x04	0x21	Audio Serial Interface 3, Audio Bus Format Control Register
0	4	34	0x00	0x04	0x22	Audio Serial Interface 3, Data Offset Control Register
0	4	35-36	0x00	0x04	0x23-0x24	Reserved Registers
0	4	37	0x00	0x04	0x25	Audio Serial Interface 3, ADC Audio Bus Format Control Register
0	4	38	0x00	0x04	0x26	Reserved Register
0	4	39	0x00	0x04	0x27	Audio Serial Interface 3, ADC Input Control
0	4	40	0x00	0x04	0x28	Audio Serial Interface 3, DAC Output Control
0	4	41	0x00	0x04	0x29	Reserved Register
0	4	42	0x00	0x04	0x2A	Audio Serial Interface 3, WCLK and BCLK Control Register

Table 12. Summary of Register Map (continued)

Decimal			Hex			DESCRIPTION
BOOK NO.	PAGE NO.	REG. NO.	BOOK NO.	PAGE NO.	REG. NO.	
0	4	43	0x00	0x04	0x2B	Audio Serial Interface 3, Bit Clock N Divider Input Control
0	4	44	0x00	0x04	0x2C	Audio Serial Interface 3, Bit Clock N Divider
0	4	45	0x00	0x04	0x2D	Audio Serial Interface 3, Word Clock N Divider
0	4	46	0x00	0x04	0x2E	Audio Serial Interface 3, BCLK and WCLK Output
0	4	47	0x00	0x04	0x2F	Audio Serial Interface 3, Data Output
0	4	48	0x00	0x04	0x30	Audio Serial Interface 3, ADC WCLK and BCLK Control
0	4	49	0x00	0x04	0x31	Audio Serial Interface 1, L1/R1 Input Control
0	4	50	0x00	0x04	0x32	Audio Serial Interface 1, L2/R2 Input Control
0	4	51	0x00	0x04	0x33	Audio Serial Interface 1, L3/R3 Input Control
0	4	52	0x00	0x04	0x34	Audio Serial Interface 1, L4/R4 Input Control
0	4	53	0x00	0x04	0x35	Audio Serial Interface 2, WCLK and BCLK Input Multiplexers Control
0	4	54	0x00	0x04	0x36	Audio Serial Interface 2, DIN Input Multiplexer Control
0	4	55	0x00	0x04	0x37	Audio Serial Interface 3, WCLK and BCLK Input Multiplexers Control
0	4	56	0x00	0x04	0x38	Audio Serial Interface 3, DIN Input Multiplexer Control
0	4	57-64	0x00	0x04	0x39-0x40	Reserved Registers
0	4	65	0x00	0x04	0x41	WCLK1 (Input/Output) Pin Control
0	4	66	0x00	0x04	0x42	Reserved Register
0	4	67	0x00	0x04	0x43	DOUT1 (Output) Pin Control
0	4	68	0x00	0x04	0x44	DIN1 (Input) Pin Control
0	4	69	0x00	0x04	0x45	WCLK2 (Input/Output) Pin Control
0	4	70	0x00	0x04	0x46	BCLK2 (Input/Output) Pin Control
0	4	71	0x00	0x04	0x47	DOUT2 (Output) Pin Control
0	4	72	0x00	0x04	0x48	DIN2 (Input) Pin Control
0	4	73	0x00	0x04	0x49	WCLK3 (Input/Output) Pin Control
0	4	74	0x00	0x04	0x4A	BCLK3 (Input/Output) Pin Control
0	4	75	0x00	0x04	0x4B	DOUT3 (Output) Pin Control
0	4	76	0x00	0x04	0x4C	DIN3 (Input) Pin Control
0	4	77-85	0x00	0x04	0x4D-0x55	Reserved Registers
0	4	86	0x00	0x04	0x56	GPIO1 (Input/Output) Pin Control
0	4	87	0x00	0x04	0x57	GPIO2 (Input/Output) Pin Control
0	4	88	0x00	0x04	0x58	GPIO3 (Input/Output) Pin Control
0	4	89	0x00	0x04	0x59	GPIO4 (Input/Output) Pin Control
0	4	90	0x00	0x04	0x5A	GPIO5 (Input/Output) Pin Control
0	4	91	0x00	0x04	0x5B	GPIO6 (Input/Output) Pin Control
0	4	92-95	0x00	0x04	0x5C-0x5F	Reserved Registers
0	4	96	0x00	0x04	0x60	GPO1 (Output) Pin Control
0	4	97-99	0x00	0x04	0x61-0x63	Reserved Registers
0	4	100	0x00	0x04	0x64	Digital Microphone Clock Control
0	4	101	0x00	0x04	0x65	Digital Microphone 1 Input Pin Control
0	4	102	0x00	0x04	0x66	Digital Microphone 2 Input Pin Control
0	4	103	0x00	0x04	0x67	Reserved Register
0	4	104	0x00	0x04	0x68	Bit-Bang Output

Table 12. Summary of Register Map (continued)

Decimal			Hex			DESCRIPTION
BOOK NO.	PAGE NO.	REG. NO.	BOOK NO.	PAGE NO.	REG. NO.	
0	4	105-106	0x00	0x04	0x69-0x6A	Reserved Registers
0	4	107	0x00	0x04	0x6B	Bit-Bang Input
0	4	108-112	0x00	0x04	0x6C-0x70	Reserved Registers
0	4	113	0x00	0x04	0x71	Bit-Bang miniDSP Output Control
0	4	114	0x00	0x04	0x72	Reserved Register
0	4	115	0x00	0x04	0x73	Audio Serial Interface 1, ADC BCLK and ADC WCLK Output
0	4	116	0x00	0x04	0x74	Audio Serial Interface 2, ADC BCLK and ADC WCLK Output
0	4	117	0x00	0x04	0x75	Audio Serial Interface 3, ADC BCLK and ADC WCLK Output
0	4	118	0x00	0x04	0x76	miniDSP Data Port Control
0	4	119	0x00	0x04	0x77	Digital Audio Engine Synchronization Control
0	4	120-127	0x00	0x04	0x78-0x7F	Reserved Registers
0	252	0	0x00	0xFC	0x00	Page Select Register
0	252	1	0x00	0xFC	0x01	SAR Buffer Mode Data (MSB) and Buffer Flags
0	252	2	0x00	0xFC	0x02	SAR Buffer Mode Data (LSB)
0	252	3-127	0x00	0xFC	0x03-0x7F	Reserved Registers
20	0	0	0x14	0x00	0x00	Page Select Register
20	0	1-126	0x14	0x00	0x01-0x7E	Reserved Registers
20	0	127	0x14	0x00	0x7F	Book Selection Register
20	1-26	0	0x14	0x01-0x1A	0x00	Page Select Register
20	1-26	1-7	0x14	0x01-0x1A	0x01-0x07	Reserved Registers
20	1-26	8-127	0x14	0x01-0x1A	0x08-0x7F	ADC Fixed Coefficients C(0:767)
40	0	0	0x28	0x00	0x00	Page Select Register
40	0	1	0x28	0x00	0x01	ADC Adaptive CRAM Configuration Register
40	0	2-126	0x28	0x00	0x02-0x7E	Reserved Registers
40	0	127	0x28	0x00	0x7F	Book Selection Register
40	1-17	0	0x28	0x01-0x11	0x00	Page Select Register
40	1-17	1-7	0x28	0x01-0x11	0x01-0x07	Reserved Registers
40	1-17	8-127	0x28	0x01-0x11	0x08-0x7F	ADC Adaptive Coefficients C(0:509)
40	18	0	0x28	0x12	0x00	Page Select Register
40	18	1-7	0x28	0x12	0x01-0x07	Reserved Registers
40	18	8-15	0x28	0x12	0x08-0x0F	ADC Adaptive Coefficients C(510:511)
40	18	16-127	0x28	0x12	0x10-0x7F	Reserved Registers
60	0	0	0x3C	0x00	0x00	Page Select Register
60	0	1-126	0x3C	0x00	0x01-0x7E	Reserved Registers
60	0	127	0x3C	0x00	0x7F	Book Selection Register

Table 12. Summary of Register Map (continued)

Decimal			Hex			DESCRIPTION
BOOK NO.	PAGE NO.	REG. NO.	BOOK NO.	PAGE NO.	REG. NO.	
60	1-35	0	0x3C	0x01-0x23	0x00	Page Select Register
60	1-35	1-7	0x3C	0x01-0x23	0x01-0x07	Reserved Registers
60	1-35	8-127	0x3C	0x01-0x23	0x08-0x7F	DAC Fixed Coefficients C(0:1023)
80	0	0	0x50	0x00	0x00	Page Select Register
80	0	1	0x50	0x00	0x01	DAC Adaptive Coefficient Bank #1 Configuration Register
80	0	2-126	0x50	0x00	0x02-0x7E	Reserved Registers
80	0	127	0x50	0x00	0x7F	Book Selection Register
80	1-17	0	0x50	0x01-0x11	0x00	Page Select Register
80	1-17	1-7	0x50	0x01-0x11	0x01-0x07	Reserved Registers
80	1-17	8-127	0x50	0x01-0x11	0x08-0x7F	DAC Adaptive Coefficient Bank #1 C(0:509)
80	18	0	0x50	0x12	0x00	Page Select Register
80	18	1-7	0x50	0x12	0x01-0x07	Reserved Registers
80	18	8-15	0x50	0x12	0x08-0x0F	DAC Adaptive Coefficient Bank #1 C(510:511)
80	18	16-127	0x50	0x12	0x10-0x7F	Reserved Registers
82	0	0	0x52	0x00	0x00	Page Select Register
82	0	1	0x52	0x00	0x01	DAC Adaptive Coefficient Bank #2 Configuration Register
82	0	2-126	0x52	0x00	0x02-0x7E	Reserved Registers
82	0	127	0x52	0x00	0x7F	Book Selection Register
82	1-17	0	0x52	0x01-0x11	0x00	Page Select Register
82	1-17	1-7	0x52	0x01-0x11	0x01-0x07	Reserved Registers
82	1-17	8-127	0x52	0x01-0x11	0x08-0x7F	DAC Adaptive Coefficient Bank #2 C(0:509)
82	18	0	0x52	0x12	0x00	Page Select Register
82	18	1-7	0x52	0x12	0x01-0x07	Reserved Registers
82	18	8-15	0x52	0x12	0x08-0x0F	DAC Adaptive Coefficient Bank #2 C(510:511)
82	18	16-127	0x52	0x12	0x10-0x7F	Reserved Registers
100	0	0	0x64	0x00	0x00	Page Select Register
100	0	1-46	0x64	0x00	0x01-0x2E	Reserved Registers
100	0	47	0x64	0x00	0x2F	Non-Programmable Override Options
100	0	48	0x64	0x00	0x30	ADC miniDSP_A Instruction Control Register 1
100	0	49	0x64	0x00	0x31	ADC miniDSP_A Instruction Control Register 2
100	0	50	0x64	0x00	0x32	ADC miniDSP_A CIC Input and Decimation Ratio Control Register
100	0	51-56	0x64	0x00	0x33-0x38	Reserved Registers
100	0	57	0x64	0x00	0x39	ADC miniDSP_A Instruction Control Register 3

Table 12. Summary of Register Map (continued)

Decimal			Hex			DESCRIPTION
BOOK NO.	PAGE NO.	REG. NO.	BOOK NO.	PAGE NO.	REG. NO.	
100	0	58	0x64	0x00	0x3A	ADC miniDSP_A ISR Interrupt Control
100	0	59	0x64	0x00	0x3B	Reserved Registers
100	0	60	0x64	0x00	0x3C	ADC miniDSP_A Secondary CIC Input Control
100	0	61	0x64	0x00	0x3D	miniDSP_A to Audio Serial Interface Handoff Control
100	0	62-126	0x64	0x00	0x3E-0x7E	Reserved Registers
100	0	127	0x64	0x00	0x7F	Book Selection Register
100	1-52	0	0x64	0x01-0x34	0x00	Page Select Register
100	1-52	1-7	0x64	0x01-0x34	0x01-0x07	Reserved Registers
100	1-52	8-127	0x64	0x01-0x34	0x08-0x7F	miniDSP_A Instructions
120	0	0	0x78	0x00	0x00	Page Select Register
120	0	1-46	0x78	0x00	0x01-0x2E	Reserved Registers
120	0	47	0x78	0x00	0x2F	Non-Programmable Override Options
120	0	48	0x78	0x00	0x30	DAC miniDSP_D Instruction Control Register 1
120	0	49	0x78	0x00	0x31	DAC miniDSP_D Instruction Control Register 2
120	0	50	0x78	0x00	0x32	DAC miniDSP_D Interpolation Factor Control Register
120	0	51-56	0x78	0x00	0x33-0x38	Reserved Registers
120	0	57	0x78	0x00	0x39	DAC miniDSP_D Instruction Control Register 3
120	0	58	0x78	0x00	0x3A	DAC miniDSP_D ISR Interrupt Control
120	0	59-126	0x78	0x00	0x3B-0x7E	Reserved Registers
120	0	127	0x78	0x00	0x7F	Book Selection Register
120	1-103	0	0x78	0x01-0x67	0x00	Page Select Register
120	1-103	1-7	0x78	0x01-0x67	0x01-0x07	Reserved Registers
120	1-103	8-127	0x78	0x01-0x67	0x08-0x7F	miniDSP_D Instructions

PACKAGING INFORMATION

Orderable Device	Status (1)	Package Type	Package Drawing	Pins	Package Qty	Eco Plan (2)	Lead/Ball Finish	MSL Peak Temp (3)	Op Temp (°C)	Device Marking (4/5)	Samples
TLV320AIC3263IYZFR	ACTIVE	DSBGA	YZF	81	2500	Green (RoHS & no Sb/Br)	SNAGCU	Level-1-260C-UNLIM	-40 to 85	AIC32AA	Samples
TLV320AIC3263IYZFT	ACTIVE	DSBGA	YZF	81	250	Green (RoHS & no Sb/Br)	SNAGCU	Level-1-260C-UNLIM	-40 to 85	AIC32AA	Samples

(1) The marketing status values are defined as follows:

ACTIVE: Product device recommended for new designs.

LIFEBUY: TI has announced that the device will be discontinued, and a lifetime-buy period is in effect.

NRND: Not recommended for new designs. Device is in production to support existing customers, but TI does not recommend using this part in a new design.

PREVIEW: Device has been announced but is not in production. Samples may or may not be available.

OBsolete: TI has discontinued the production of the device.

(2) Eco Plan - The planned eco-friendly classification: Pb-Free (RoHS), Pb-Free (RoHS Exempt), or Green (RoHS & no Sb/Br) - please check <http://www.ti.com/productcontent> for the latest availability information and additional product content details.

TBD: The Pb-Free/Green conversion plan has not been defined.

Pb-Free (RoHS): TI's terms "Lead-Free" or "Pb-Free" mean semiconductor products that are compatible with the current RoHS requirements for all 6 substances, including the requirement that lead not exceed 0.1% by weight in homogeneous materials. Where designed to be soldered at high temperatures, TI Pb-Free products are suitable for use in specified lead-free processes.

Pb-Free (RoHS Exempt): This component has a RoHS exemption for either 1) lead-based flip-chip solder bumps used between the die and package, or 2) lead-based die adhesive used between the die and leadframe. The component is otherwise considered Pb-Free (RoHS compatible) as defined above.

Green (RoHS & no Sb/Br): TI defines "Green" to mean Pb-Free (RoHS compatible), and free of Bromine (Br) and Antimony (Sb) based flame retardants (Br or Sb do not exceed 0.1% by weight in homogeneous material)

(3) MSL, Peak Temp. -- The Moisture Sensitivity Level rating according to the JEDEC industry standard classifications, and peak solder temperature.

(4) There may be additional marking, which relates to the logo, the lot trace code information, or the environmental category on the device.

(5) Multiple Device Markings will be inside parentheses. Only one Device Marking contained in parentheses and separated by a "~" will appear on a device. If a line is indented then it is a continuation of the previous line and the two combined represent the entire Device Marking for that device.

Important Information and Disclaimer: The information provided on this page represents TI's knowledge and belief as of the date that it is provided. TI bases its knowledge and belief on information provided by third parties, and makes no representation or warranty as to the accuracy of such information. Efforts are underway to better integrate information from third parties. TI has taken and continues to take reasonable steps to provide representative and accurate information but may not have conducted destructive testing or chemical analysis on incoming materials and chemicals. TI and TI suppliers consider certain information to be proprietary, and thus CAS numbers and other limited information may not be available for release.

In no event shall TI's liability arising out of such information exceed the total purchase price of the TI part(s) at issue in this document sold by TI to Customer on an annual basis.

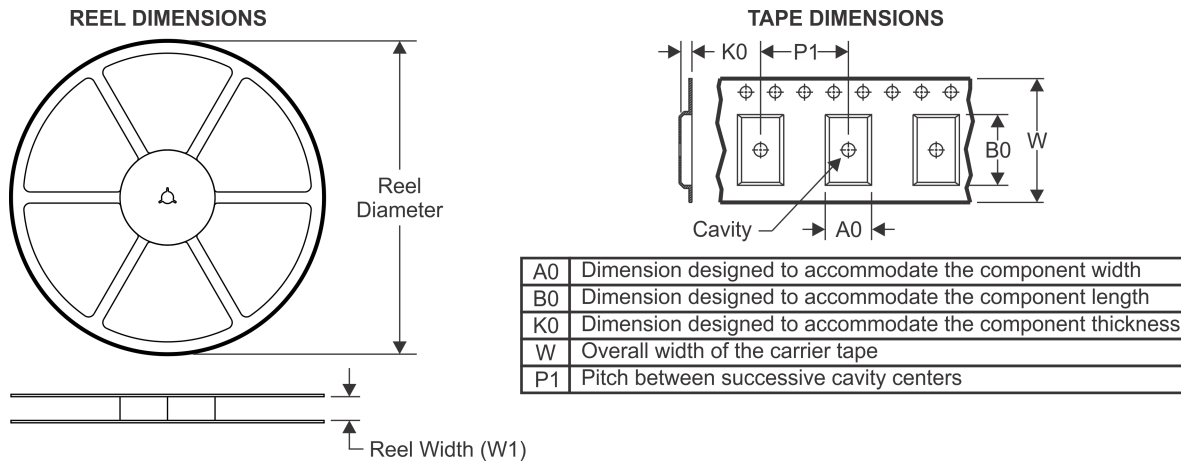
TAPE AND REEL INFORMATION

QUADRANT ASSIGNMENTS FOR PIN 1 ORIENTATION IN TAPE

*All dimensions are nominal

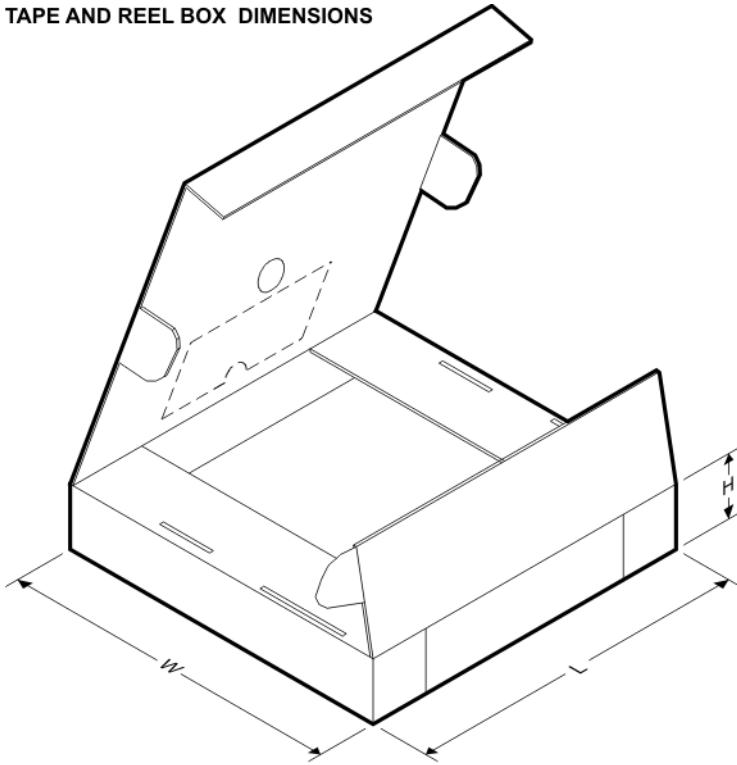
Device	Package Type	Package Drawing	Pins	SPQ	Reel Diameter (mm)	Reel Width W1 (mm)	A0 (mm)	B0 (mm)	K0 (mm)	P1 (mm)	W (mm)	Pin1 Quadrant
TLV320AIC3263IYZFR	DSBGA	YZF	81	2500	330.0	12.4	5.04	5.07	0.75	8.0	12.0	Q1
TLV320AIC3263IYZFT	DSBGA	YZF	81	250	330.0	12.4	5.04	5.07	0.75	8.0	12.0	Q1

TAPE AND REEL BOX DIMENSIONS

*All dimensions are nominal

Device	Package Type	Package Drawing	Pins	SPQ	Length (mm)	Width (mm)	Height (mm)
TLV320AIC3263IYZFR	DSBGA	YZF	81	2500	367.0	367.0	35.0
TLV320AIC3263IYZFT	DSBGA	YZF	81	250	367.0	367.0	35.0

YZF (R-XBGA-N81)

DIE-SIZE BALL GRID ARRAY

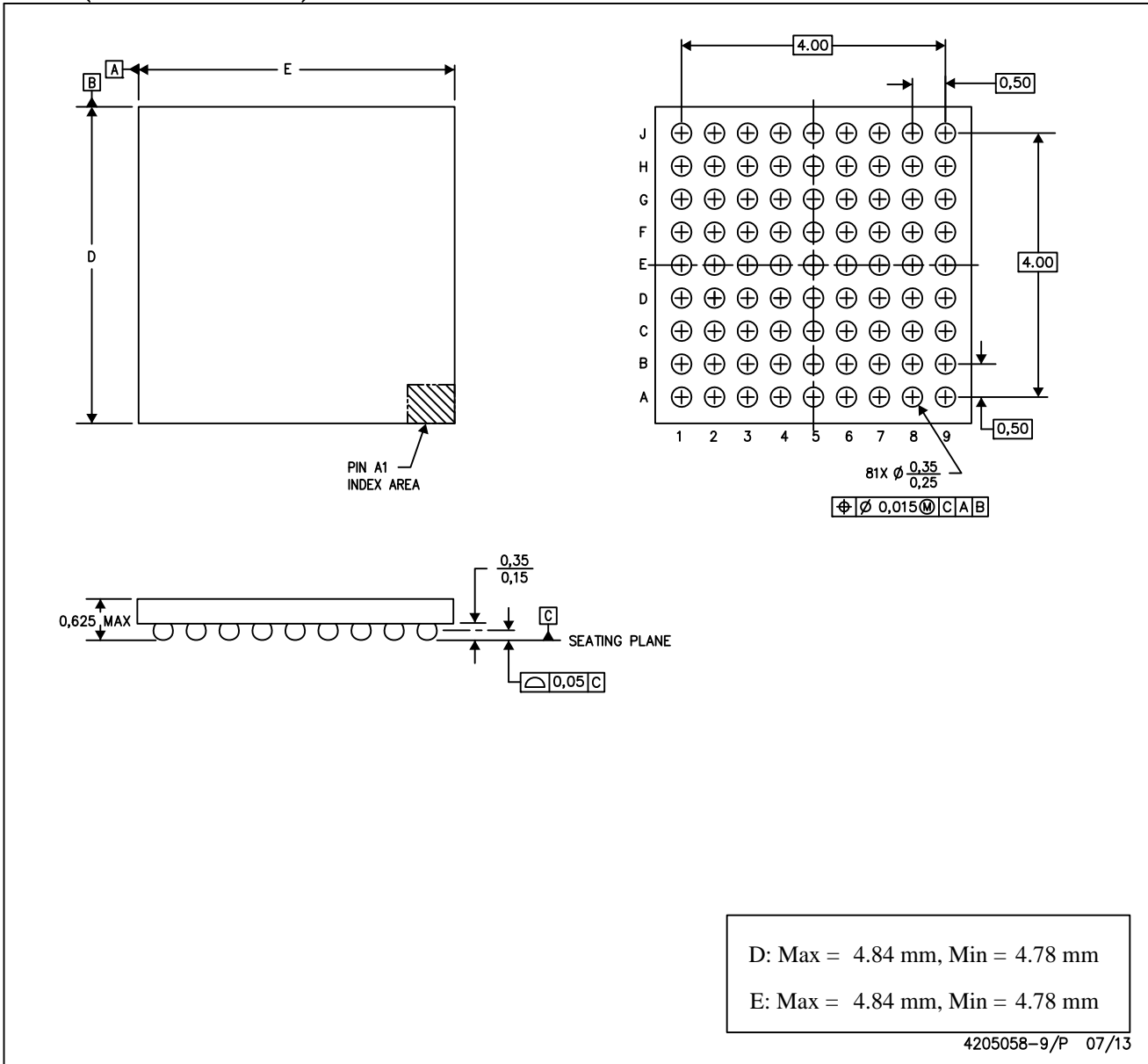

- NOTES: A. All linear dimensions are in millimeters. Dimensioning and tolerancing per ASME Y14.5M-1994.
 B. This drawing is subject to change without notice.
 C. NanoFree™ package configuration.

NanoFree is a trademark of Texas Instruments.

IMPORTANT NOTICE

Texas Instruments Incorporated (TI) reserves the right to make corrections, enhancements, improvements and other changes to its semiconductor products and services per JESD46, latest issue, and to discontinue any product or service per JESD48, latest issue. Buyers should obtain the latest relevant information before placing orders and should verify that such information is current and complete.

TI's published terms of sale for semiconductor products (<http://www.ti.com/sc/docs/stdterms.htm>) apply to the sale of packaged integrated circuit products that TI has qualified and released to market. Additional terms may apply to the use or sale of other types of TI products and services.

Reproduction of significant portions of TI information in TI data sheets is permissible only if reproduction is without alteration and is accompanied by all associated warranties, conditions, limitations, and notices. TI is not responsible or liable for such reproduced documentation. Information of third parties may be subject to additional restrictions. Resale of TI products or services with statements different from or beyond the parameters stated by TI for that product or service voids all express and any implied warranties for the associated TI product or service and is an unfair and deceptive business practice. TI is not responsible or liable for any such statements.

Buyers and others who are developing systems that incorporate TI products (collectively, "Designers") understand and agree that Designers remain responsible for using their independent analysis, evaluation and judgment in designing their applications and that Designers have full and exclusive responsibility to assure the safety of Designers' applications and compliance of their applications (and of all TI products used in or for Designers' applications) with all applicable regulations, laws and other applicable requirements. Designer represents that, with respect to their applications, Designer has all the necessary expertise to create and implement safeguards that (1) anticipate dangerous consequences of failures, (2) monitor failures and their consequences, and (3) lessen the likelihood of failures that might cause harm and take appropriate actions. Designer agrees that prior to using or distributing any applications that include TI products, Designer will thoroughly test such applications and the functionality of such TI products as used in such applications.

TI's provision of technical, application or other design advice, quality characterization, reliability data or other services or information, including, but not limited to, reference designs and materials relating to evaluation modules, (collectively, "TI Resources") are intended to assist designers who are developing applications that incorporate TI products; by downloading, accessing or using TI Resources in any way, Designer (individually or, if Designer is acting on behalf of a company, Designer's company) agrees to use any particular TI Resource solely for this purpose and subject to the terms of this Notice.

TI's provision of TI Resources does not expand or otherwise alter TI's applicable published warranties or warranty disclaimers for TI products, and no additional obligations or liabilities arise from TI providing such TI Resources. TI reserves the right to make corrections, enhancements, improvements and other changes to its TI Resources. TI has not conducted any testing other than that specifically described in the published documentation for a particular TI Resource.

Designer is authorized to use, copy and modify any individual TI Resource only in connection with the development of applications that include the TI product(s) identified in such TI Resource. NO OTHER LICENSE, EXPRESS OR IMPLIED, BY ESTOPPEL OR OTHERWISE TO ANY OTHER TI INTELLECTUAL PROPERTY RIGHT, AND NO LICENSE TO ANY TECHNOLOGY OR INTELLECTUAL PROPERTY RIGHT OF TI OR ANY THIRD PARTY IS GRANTED HEREIN, including but not limited to any patent right, copyright, mask work right, or other intellectual property right relating to any combination, machine, or process in which TI products or services are used. Information regarding or referencing third-party products or services does not constitute a license to use such products or services, or a warranty or endorsement thereof. Use of TI Resources may require a license from a third party under the patents or other intellectual property of the third party, or a license from TI under the patents or other intellectual property of TI.

TI RESOURCES ARE PROVIDED "AS IS" AND WITH ALL FAULTS. TI DISCLAIMS ALL OTHER WARRANTIES OR REPRESENTATIONS, EXPRESS OR IMPLIED, REGARDING RESOURCES OR USE THEREOF, INCLUDING BUT NOT LIMITED TO ACCURACY OR COMPLETENESS, TITLE, ANY EPIDEMIC FAILURE WARRANTY AND ANY IMPLIED WARRANTIES OF MERCHANTABILITY, FITNESS FOR A PARTICULAR PURPOSE, AND NON-INFRINGEMENT OF ANY THIRD PARTY INTELLECTUAL PROPERTY RIGHTS. TI SHALL NOT BE LIABLE FOR AND SHALL NOT DEFEND OR INDEMNIFY DESIGNER AGAINST ANY CLAIM, INCLUDING BUT NOT LIMITED TO ANY INFRINGEMENT CLAIM THAT RELATES TO OR IS BASED ON ANY COMBINATION OF PRODUCTS EVEN IF DESCRIBED IN TI RESOURCES OR OTHERWISE. IN NO EVENT SHALL TI BE LIABLE FOR ANY ACTUAL, DIRECT, SPECIAL, COLLATERAL, INDIRECT, PUNITIVE, INCIDENTAL, CONSEQUENTIAL OR EXEMPLARY DAMAGES IN CONNECTION WITH OR ARISING OUT OF TI RESOURCES OR USE THEREOF, AND REGARDLESS OF WHETHER TI HAS BEEN ADVISED OF THE POSSIBILITY OF SUCH DAMAGES.

Unless TI has explicitly designated an individual product as meeting the requirements of a particular industry standard (e.g., ISO/TS 16949 and ISO 26262), TI is not responsible for any failure to meet such industry standard requirements.

Where TI specifically promotes products as facilitating functional safety or as compliant with industry functional safety standards, such products are intended to help enable customers to design and create their own applications that meet applicable functional safety standards and requirements. Using products in an application does not by itself establish any safety features in the application. Designers must ensure compliance with safety-related requirements and standards applicable to their applications. Designer may not use any TI products in life-critical medical equipment unless authorized officers of the parties have executed a special contract specifically governing such use. Life-critical medical equipment is medical equipment where failure of such equipment would cause serious bodily injury or death (e.g., life support, pacemakers, defibrillators, heart pumps, neurostimulators, and implantables). Such equipment includes, without limitation, all medical devices identified by the U.S. Food and Drug Administration as Class III devices and equivalent classifications outside the U.S.

TI may expressly designate certain products as completing a particular qualification (e.g., Q100, Military Grade, or Enhanced Product). Designers agree that it has the necessary expertise to select the product with the appropriate qualification designation for their applications and that proper product selection is at Designers' own risk. Designers are solely responsible for compliance with all legal and regulatory requirements in connection with such selection.

Designer will fully indemnify TI and its representatives against any damages, costs, losses, and/or liabilities arising out of Designer's non-compliance with the terms and provisions of this Notice.

Looking for pricing, stock, or lifecycle information?

Click below to explore more details on WIN SOURCE:

 [View TLV320AIC3263IYZFT on WIN SOURCE](#)

 [Texas Instruments](#) Information

Optimize Your Supply Chain with WIN SOURCE Solutions

-  Global Sourcing Solution
-  Obsolete Management
-  Cost Control Management
-  Shortage Management
-  Alternative Solution
-  Excess Inventory Management