



**THE DATASHEET OF
CD4097BF**



CD40x7B CMOS Analog Multiplexers or Demultiplexers

1 Features

- High-voltage types (20V rating)
 - CD4067B – single 16-channel multiplexer or demultiplexer
- Low ON resistance: 125Ω (typ) over 15V_{p-p} signal-input range for V_{DD}–V_{SS} = 15V
- High OFF resistance: channel leakage of ±10pA (typ) at V_{DD} – V_{SS} = 10V
- Matched switch characteristics: R_{ON} = 5Ω (typ) for V_{DD} – V_{SS} = 15V
- Very low quiescent power dissipation under all digital-control input and supply conditions: 0.2μW (typ) at V_{DD} – V_{SS} = 10V
- Binary address decoding on chip
- 5V, 10V, and 15V parametric ratings
- 100% tested for quiescent current at 20V
- Standardized symmetrical output characteristics
- Maximum input current of 1μA at 18V over full package temperature range: 100nA at 18V and 25°C
- Meets all requirements of JEDEC tentative standard No. 13-B, *Standard Specifications for Description of "B" Series CMOS Devices*

2 Applications

- Analog signal and digital multiplexing
- Transmission-gate logic implementation
- A/DI and D/A conversion
- Signal gating

3 Description

CD40x7B CMOS analog multiplexers or demultiplexers are digitally controlled analog switches having low ON impedance, low OFF leakage current, and internal address decoding. When these devices are used as demultiplexers, the channel in or out terminals are the outputs and the common out or in terminals are the inputs. In addition, the ON resistance is relatively constant over the full input-signal range.

The CD4067B is a 16-channel multiplexer with four binary control inputs, A, B, C, D, and an inhibit input, arranged so that any combination of the inputs selects one switch.

A logic "1" present at the inhibit input turns all channels off.

The CD40x7B types are supplied in 24-lead hermetic dual-in-line ceramic packages (F3A suffix), 24-lead dual-in-line plastic packages (E suffix), 24-lead small-outline packages (M, M96, and NSR suffixes), and 24-lead thin shrink small-outline packages (P and PWR suffixes).

Device Information

PART NUMBER	CHANNEL	PACKAGE ⁽¹⁾
CD4067B	2 channel 8:1 differential multiplexer	PW (TSSOP, 24)
		DW (SOIC, 24)

(1) For more information, see [Section 11](#).



CD4067B, CD4097B

SCHS052C – JUNE 2003 – REVISED JULY 2024

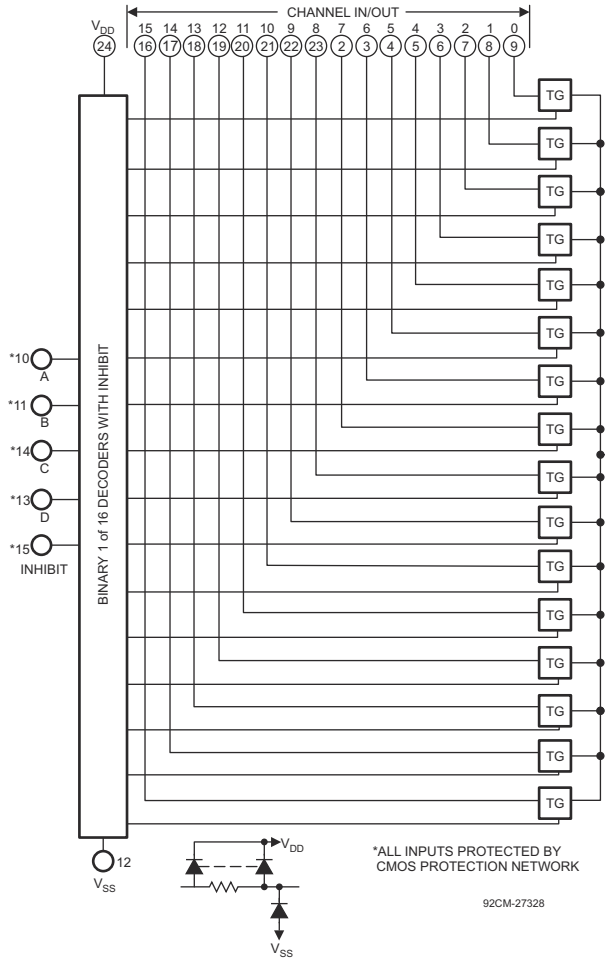

CD4067 Logic Diagram

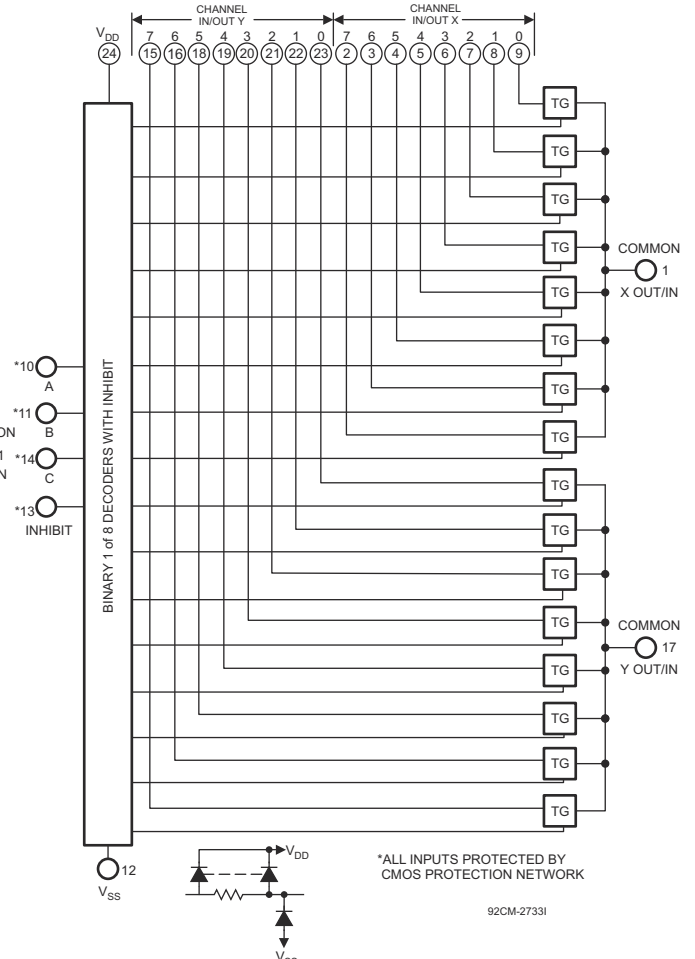

CD4097 Logic Diagram

Table of Contents

1 Features	1	7.1 Functional Block Diagram.....	12
2 Applications	1	7.2 Device Functional Modes.....	12
3 Description	1	8 Application and Implementation	14
4 Pin Configuration and Functions	3	8.1 Application Information.....	14
5 Specifications	5	8.2 Typical Application.....	14
5.1 Absolute Maximum Ratings.....	5	9 Device and Documentation Support	15
5.2 ESD Ratings.....	5	9.1 Receiving Notification of Documentation Updates... 15	
5.3 Recommended Operating Conditions.....	5	9.2 Support Resources.....	15
5.4 Thermal Information.....	6	9.3 Trademarks.....	15
5.5 Electrical Characteristics.....	6	9.4 Electrostatic Discharge Caution.....	15
5.6 AC Performance Characteristics.....	8	9.5 Glossary.....	15
5.7 Typical Characteristics.....	8	10 Revision History	15
6 Parameter Measurement Information	9	11 Mechanical, Packaging, and Orderable Information	15
6.1 Test Circuits.....	9		
7 Detailed Description	12		

4 Pin Configuration and Functions

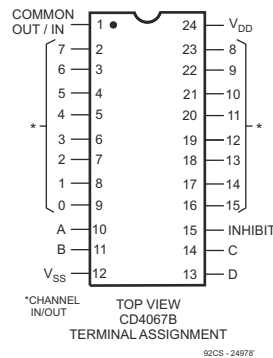

Figure 4-1. CD4067B 24 Pins (Top View)

Table 4-1. Function Table

CD4067 TRUTH TABLE					
A	B	C	D	inh	Selected Channel
X	X	X	X	1	None
0	0	0	0	0	0
1	0	0	0	0	1
0	1	0	0	0	2
1	1	0	0	0	3
0	0	1	0	0	4
1	0	1	0	0	5
0	1	1	0	0	6
1	1	1	0	0	7
0	0	0	1	0	8
1	0	0	1	0	9
0	1	0	1	0	10
1	1	0	1	0	11
0	0	1	1	0	12
1	0	1	1	0	13
0	1	1	1	0	14
1	1	1	1	0	15

Table 4-2. Function Table

CD4097 TRUTH TABLE				
A	B	C	inh	Selected Channel
X	X	X	1	None
0	0	0	0	0X, 0Y
1	0	0	0	1X, 1Y
0	1	0	0	2X, 2Y
1	1	0	0	3X, 3Y
0	0	1	0	4X, 4Y
1	0	1	0	5X, 5Y
0	1	1	0	6X, 6Y
1	1	1	0	7X, 7Y

5 Specifications

5.1 Absolute Maximum Ratings

over operating free-air temperature range (unless otherwise noted)^{(1) (2)}

		MIN	MAX	UNIT
$V_{DD} - V_{SS}$	Supply voltage		20	V
V_{DD}		-0.5	20	V
V_{SS}		-20	0.5	V
I_{SEL} or I_{EN}	Logic control input pin current (\overline{EN} , Ax, SELx)	-30	30	mA
V_S or V_D	Source or drain voltage (Sx, D)	$V_{SS}-0.5$	$V_{DD}+0.5$	V
I_S or I_D (CONT)	Source or drain continuous current (Sx, D)	-20	20	mA
T_J	Junction temperature		150	°C
T_{stg}	Storage temperature	-65	150	°C

- (1) Stresses beyond those listed under *Absolute Maximum Rating* may cause permanent damage to the device. These are stress ratings only, which do not imply functional operation of the device at these or any other conditions beyond those indicated under *Recommended Operating Condition*. Exposure to absolute-maximum-rated conditions for extended periods may affect device reliability.
- (2) All voltages are with respect to ground, unless otherwise specified.

5.2 ESD Ratings

		VALUE	UNIT	
$V_{(ESD)}$	Electrostatic discharge	Human body model (HBM), per ANSI/ESDA/ JEDEC JS-001, all pins ⁽¹⁾	±2000	V
		Charged device model (CDM), per JEDEC specification JESD22-C101, all pins ⁽²⁾	±200	

- (1) JEDEC document JEP155 states that 500V HBM allows safe manufacturing with a standard ESD control process.
- (2) JEDEC document JEP157 states that 250V CDM allows safe manufacturing with a standard ESD control process.

5.3 Recommended Operating Conditions

over operating free-air temperature range (unless otherwise noted)

		MIN	NOM	MAX	UNIT
$V_{DD} - V_{SS}$ ⁽¹⁾	Power supply voltage differential	3		18	V
V_{DD}	Positive power supply voltage	3		18	V
V_S or V_D	Signal path input/output voltage (source or drain pin) (Sx, D)	V_{SS}		V_{DD}	V
V_{SEL} or V_{EN}	Address or enable pin voltage	0		V_{DD}	V
I_S or I_D (CONT)	Source or drain continuous current (Sx, D)	-10		10	mA
T_A	Ambient temperature	-55		125	°C

- (1) V_{DD} and V_{SS} can be any value as long as $3V \leq (V_{DD} - V_{SS}) \leq 24V$, and the minimum V_{DD} is met.

5.4 Thermal Information

THERMAL METRIC ⁽¹⁾		CD406x	CD406x	UNIT
		D (SOIC)	PW (TSSOP)	
		14 PINS	14 PINS	
R _{θJA}	Junction-to-ambient thermal resistance	109.7	101.8	°C/W
R _{θJC(top)}	Junction-to-case (top) thermal resistance	69.4	44.3	°C/W
R _{θJB}	Junction-to-board thermal resistance	67.9	68.2	°C/W
Ψ _{JT}	Junction-to-top characterization parameter	25.8	3.2	°C/W
Ψ _{JB}	Junction-to-board characterization parameter	67.1	67.6	°C/W

(1) For more information about traditional and new thermal metrics, see the [Semiconductor and IC Package Thermal Metrics](#) application report.

5.5 Electrical Characteristics

Over operating free-air temperature range, V_{SUPPLY} = ±5V, and R_L = 100Ω, (unless otherwise noted)⁽¹⁾

PARAMETER	TEST CONDITIONS	TEST CONDITIONS	TEST CONDITIONS	TEST CONDITIONS	MIN	TYP	MAX	UNIT		
SIGNAL INPUTS (V_{IS}) AND OUTPUTS (V_{OS})										
I _{DD}	Quiescent Device Current	V _{IS} = 0 to 5V V _{DD} = 5V	T _A = -55°C					13	μA	
			T _A = -40°C					13		
			T _A = 25°C			5	14.5			
			T _A = 85°C				150			
			T _A = 125°C				150			
		V _{IS} = 0 to 5V V _{DD} = 10V	T _A = -55°C							14
			T _A = -40°C							14
			T _A = 25°C			6	15.5			
			T _A = 85°C				300			
			T _A = 125°C				300			
		V _{IS} = 0 to 5V V _{DD} = 15V	T _A = -55°C							20
			T _A = -40°C							20
			T _A = 25°C			6	20			
			T _A = 85°C				600			
			T _A = 125°C				600			
		V _{IS} = 0 to 5V V _{DD} = 20V	T _A = -55°C							100
			T _A = -40°C							100
			T _A = 25°C			7	100			
			T _A = 85°C				3000			
			T _A = 125°C				3000			
r _{ON}	ON Resistance r _{ON} Max	to (V _{DD} -V _{SS})/2, V _C = V _{DD} , R _L = 10kΩ returned V _{IS} = V _{SS} to V _{DD}	V _{DD} = 5V	T _A = -55°C				800	Ω	
				T _A = -40°C				850		
				T _A = 25°C		470	1050			
				T _A = 85°C			1200			
				T _A = 125°C			1300			
			V _{DD} = 10V	T _A = -55°C			310			
				T _A = -40°C			330			
				T _A = 25°C		180	400			
				T _A = 85°C			520			
				T _A = 125°C			550			
			V _{DD} = 15V	T _A = -55°C			200			
				T _A = -40°C			210			
T _A = 25°C		125		240						
V _{DD} = 15V	T _A = 85°C			300						
	T _A = 125°C			320						

5.5 Electrical Characteristics (continued)

Over operating free-air temperature range, $V_{SUPPLY} = \pm 5V$, and $R_L = 100\Omega$, (unless otherwise noted)⁽¹⁾

PARAMETER			TEST CONDITIONS	TEST CONDITIONS	TEST CONDITIONS	TEST CONDITIONS	MIN	TYP	MAX	UNIT	
ΔR_{ON}	On-state resistance difference between any two switches		$R_L = 10k\Omega, V_C = V_{DD}$	$V_{DD} = 5V$					15		Ω
	On-state resistance difference between any two switches	On-state resistance difference between any two switches		$V_{DD} = 10V$					10		
	On-state resistance difference between any two switches	On-state resistance difference between any two switches		$V_{DD} = 15V$					5		
OFF Channel Leakage Current: Any Channel OFF (Max) or ALL Channels OFF (COMMON OUT/IN) (Max)				$V_{DD} - V_{SS} = 18V$	$T_A = -55^\circ C$				± 100	nA	
					$T_A = -40^\circ C$				± 100		
					$T_A = 25^\circ C$			± 0.1	$\pm 100^{(2)}$		
					$T_A = 85^\circ C$				$\pm 1000^{(2)}$		
					$T_A = 125^\circ C$				$\pm 1000^{(2)}$		
C_{IS}	Input capacitance	$V_S = 0V$ $f = 1MHz$ CD4067	$V_{DD} = 5V, V_C = V_{SS} = -5V$	$V_{DD} = 5V, V_C = V_{SS} = -5V$	$V_{DD} = 5V, V_C = V_{SS} = -5V$	$V_{DD} = 5V, V_C = V_{SS} = -5V$		5		pF	
C_{OS}	Output capacitance	$V_S = 0V$ $f = 1MHz$ CD4067	$V_{DD} = 5V, V_C = V_{SS} = -5V$	$V_{DD} = 5V, V_C = V_{SS} = -5V$	$V_{DD} = 5V, V_C = V_{SS} = -5V$	$V_{DD} = 5V, V_C = V_{SS} = -5V$		55		pF	
C_{OS}	Output capacitance	$V_S = 0V$ $f = 1MHz$ CD4097	$V_{DD} = 5V, V_C = V_{SS} = -5V$	$V_{DD} = 5V, V_C = V_{SS} = -5V$	$V_{DD} = 5V, V_C = V_{SS} = -5V$	$V_{DD} = 5V, V_C = V_{SS} = -5V$		35		pF	
C_{IOS}	Feed through	$V_S = 0V$ $f = 1MHz$	$V_{DD} = 5V, V_C = V_{SS} = -5V$	$V_{DD} = 5V, V_C = V_{SS} = -5V$	$V_{DD} = 5V, V_C = V_{SS} = -5V$	$V_{DD} = 5V, V_C = V_{SS} = -5V$		0.2		pF	
V_{IHC}	Control input, high voltage		See Figure 6-1	$V_{DD} = 5V$					3.5		V
				$V_{DD} = 10V$					7		V
				$V_{DD} = 15V$					11		V
V_{ILC}	Control input, low voltage (max)			$V_{DD} = 5V$				1			V
				$V_{DD} = 10V$				1			V
				$V_{DD} = 15V$				1			V
I_{IN}	Input current (max)		$V_{IS} \leq V_{DD}, V_{DD} - V_{SS} = 18V, V_{CC} \leq V_{DD} - V_{SS}, V_{DD} = 18V$	$T_A = -55^\circ C$				-0.1		1	μA
				$T_A = -40^\circ C$				-0.1		1	
				$T_A = 25^\circ C$				-0.1	0.0001	1	
				$T_A = 85^\circ C$				-1		1	
	$T_A = 125^\circ C$				-1		1				
C_{IN}	Input Capacitance						5	7.5		pF	
BW	-3dB cutoff frequency (switch on)	CD4067	$V_C = V_{DD} = 5V, V_{SS} = -5V, V_{IS(p-p)} = 5V$ (sine wave centered on 0V), $R_L = 1k\Omega$ Common Out/In					14		MHz	
		CD4097						20			
	-3dB cutoff frequency (switch on)		$V_C = V_{DD} = 5V, V_{SS} = -5V, V_{IS(p-p)} = 5V$ (sine wave centered on 0V), $R_L = 1k\Omega$ Any channel					60			
THD	Total Harmonic Distortion	Total Harmonic Distortion	$V_C = V_{DD} = 5V, V_{SS} = 0V, V_{IS(p-p)} = 2V$ (sine wave centered on 0V), $R_L = 10k\Omega, f_{IS} = 1-kHz$ sine wave					0.3		%	
			$V_C = V_{DD} = 10V, V_{SS} = 0V, V_{IS(p-p)} = 3V$ (sine wave centered on 0V), $R_L = 10k\Omega, f_{IS} = 1-kHz$ sine wave					0.2			
			$V_C = V_{DD} = 15V, V_{SS} = 0V, V_{IS(p-p)} = 5V$ (sine wave centered on 0V), $R_L = 10k\Omega, f_{IS} = 1-kHz$ sine wave					0.12			
OISO	-40dB feed through frequency (switch off)	CD4067	$V_C = V_{DD} = 5V, V_{SS} = -5V, V_{IS(p-p)} = 5V$ (sine wave centered on 0V), $R_L = 1k\Omega$ Common Out/In					20		MHz	
		CD4097						12			
	-40dB feed through frequency (switch off)		$V_C = V_{DD} = 5V, V_{SS} = -5V, V_{IS(p-p)} = 5V$ (sine wave centered on 0V), $R_L = 1k\Omega$ Any channel					8			
XTALK	-40dB crosstalk frequency	Any 2 Channels						1		MHz	
		CD4097 on Common	$V_C = V_{DD} = 5V, V_{SS} = -5V, V_{IS(p-p)} = 5V$ (sine wave centered on 0V), $R_L = 1k\Omega$					10			
		CD4097 on Any						18			

5.5 Electrical Characteristics (continued)

Over operating free-air temperature range, $V_{SUPPLY} = \pm 5V$, and $R_L = 100\Omega$, (unless otherwise noted)⁽¹⁾

PARAMETER	TEST CONDITIONS	TEST CONDITIONS	TEST CONDITIONS	TEST CONDITIONS	MIN	TYP	MAX	UNIT
Crosstalk (control input to signal output)	$V_C = 10V$ (square wave), $R_L = 10k\Omega$, $V_{DD} = 10V$					75		mV

- (1) Peak-to-Peak voltage symmetrical about $(V_{DD} - V_{EE}) / 2$.
- (2) Determined by minimum feasible leakage measurement for automatic testing.

5.6 AC Performance Characteristics

$V_{DD} = +15V$, $V_{SS} = V_{EE} = 0V$,
 $T_A = 25^\circ C$ (unless otherwise noted)

PARAMETER	FROM	TO	TEST CONDITIONS	V_{CC}	MIN	TYP	MAX	UNIT
t_{pd}	Signal Input	Signal Output	$V_{IN} = V_{DD}$, $C_L = 50$ pF, $R_L = 1k\Omega$	5V		30	60	ns
				10V		15	30	
				15V		7	20	
t_{ph}	Signal Input	Signal Output	$V_{IN} = V_{DD}$, $C_L = 50$ pF, $R_L = 1k\Omega$	5V		325	650	ns
				10V		135	270	
				15V		95	190	
t_{phi}	Signal Input	Signal Output	$V_{IN} = V_{DD}$, $C_L = 50$ pF, $R_L = 1k\Omega$	5V		220	440	ns
				10V		90	180	
				15V		65	130	

5.7 Typical Characteristics

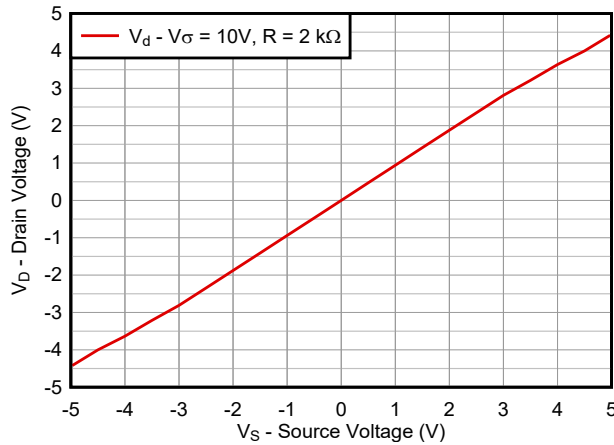

Figure 5-1. Source Voltage Input vs Drain Voltage Output

6 Parameter Measurement Information

6.1 Test Circuits

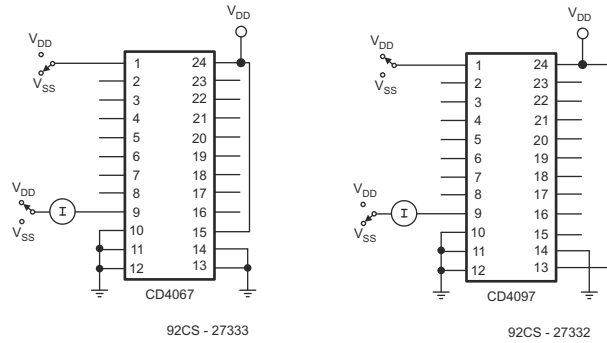

Figure 6-1. OFF Channel Leakage Current – Any Channel OFF

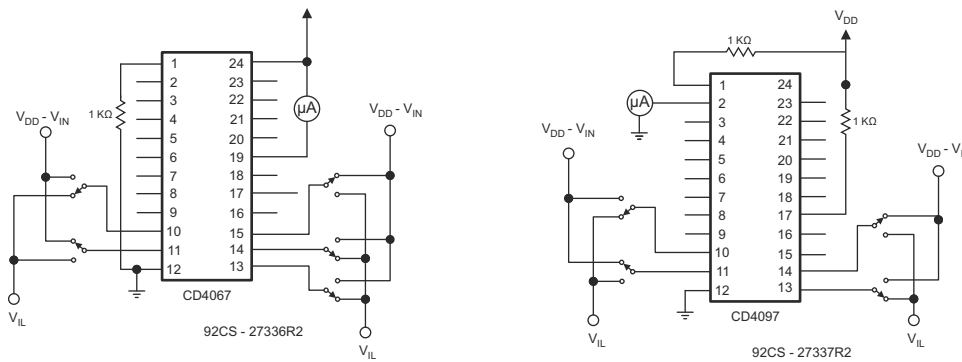

Figure 6-2. Input Voltage – Measure <2µA on all OFF Channels (For Example, Channel 12)

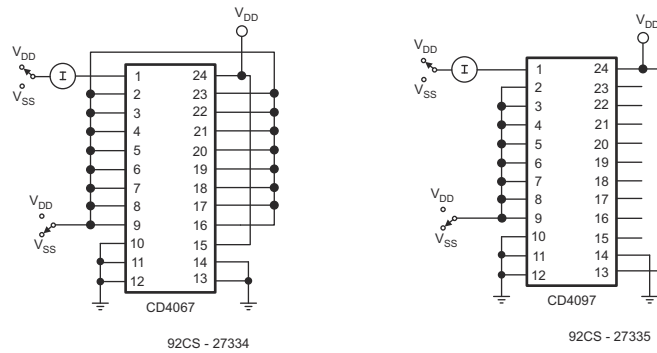

Figure 6-3. OFF Channel Leakage Current – All Channels OFF

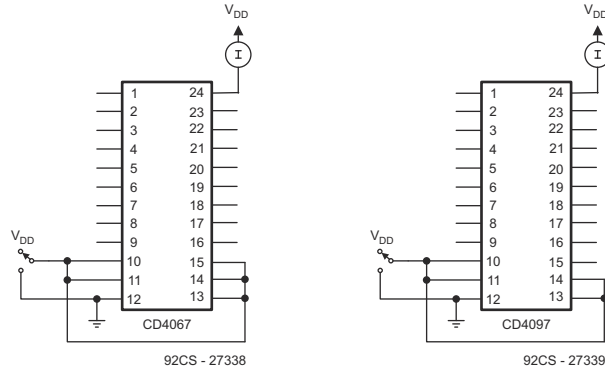

Figure 6-4. Quiescent Device Current

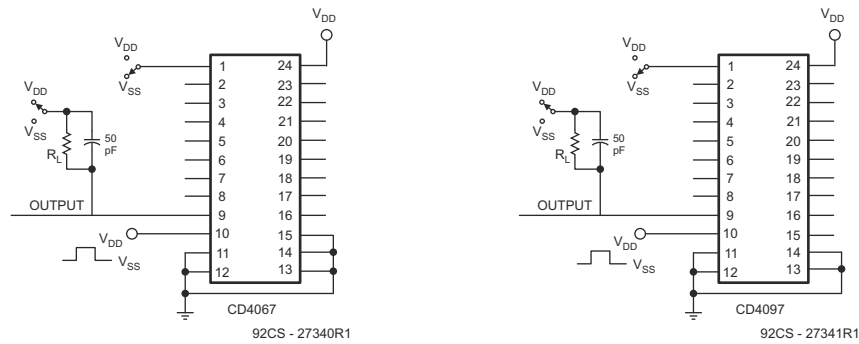

Figure 6-5. Turn-on and Turn-off Propagation Delay – Address Select Input to Signal Output (For Example,, Measured on Channel 0)

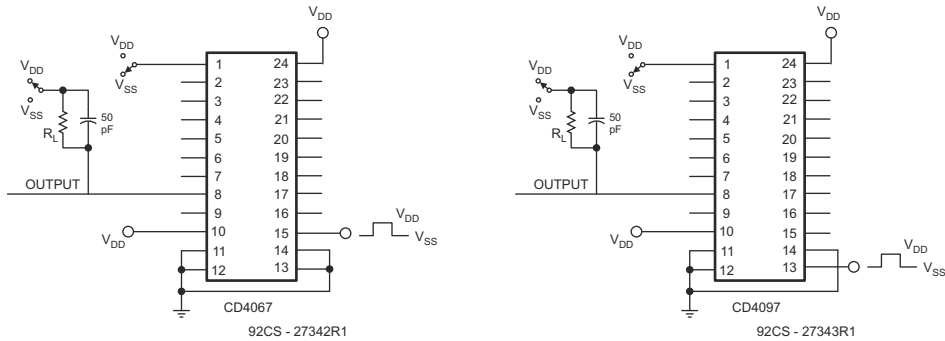

Figure 6-6. Turn-on and Turn-off Propagation Delay – Inhibit Input to Signal Output (For Example,, Measured on Channel 1)

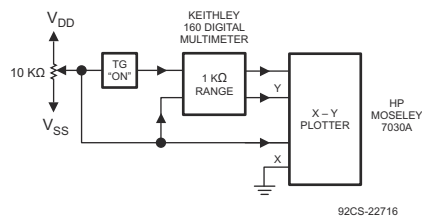

Figure 6-7. Channel ON Resistance Measurement Circuit

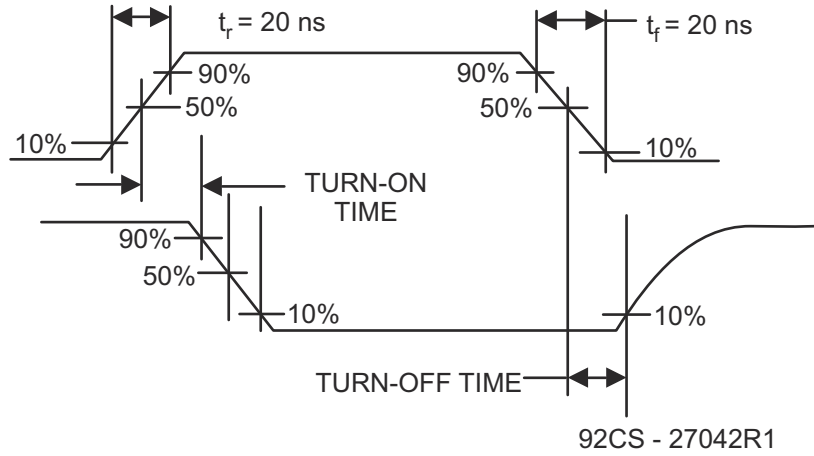

Figure 6-8. Propagation Delay Waveform Channel Being turned ON ($R_L = 10k\Omega$, $C_L = 50$ pF)

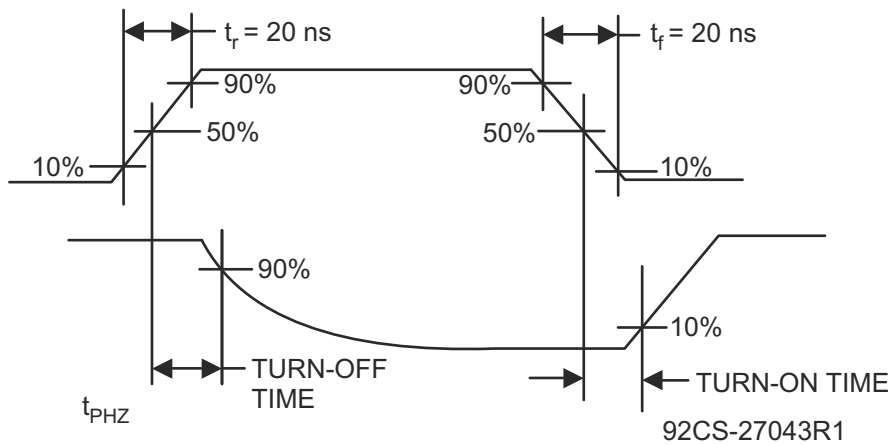

Figure 6-9. Propagation Delay Waveform Channel Being turned OFF ($R_L = 300\Omega$, $C_L = 50$ pF)

7 Detailed Description

7.1 Functional Block Diagram

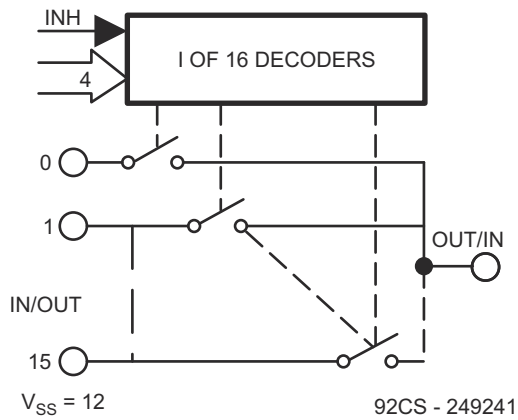

Figure 7-1. CD4067

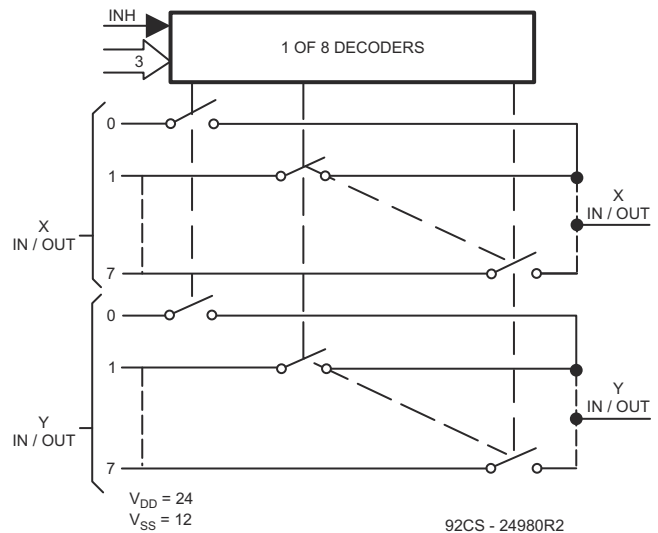

Figure 7-2. CD4097

7.2 Device Functional Modes

Table 7-1. Function Table

CD4067 TRUTH TABLE					
A	B	C	D	inh	Selected Channel
X	X	X	X	1	None
0	0	0	0	0	0
1	0	0	0	0	1
0	1	0	0	0	2
1	1	0	0	0	3
0	0	1	0	0	4
1	0	1	0	0	5
0	1	1	0	0	6
1	1	1	0	0	7
0	0	0	1	0	8
1	0	0	1	0	9
0	1	0	1	0	10
1	1	0	1	0	11
0	0	1	1	0	12
1	0	1	1	0	13
0	1	1	1	0	14
1	1	1	1	0	15

Table 7-2. Function Table

CD4097 TRUTH TABLE				
A	B	C	inh	Selected Channel
X	X	X	1	None
0	0	0	0	0X, 0Y
1	0	0	0	1X, 1Y
0	1	0	0	2X, 2Y
1	1	0	0	3X, 3Y
0	0	1	0	4X, 4Y
1	0	1	0	5X, 5Y
0	1	1	0	6X, 6Y
1	1	1	0	7X, 7Y

8 Application and Implementation

Note

Information in the following applications sections is not part of the TI component specification, and TI does not warrant its accuracy or completeness. TI's customers are responsible for determining suitability of components for their purposes, as well as validating and testing their design implementation to confirm system functionality.

8.1 Application Information

8.1.1 Special Considerations

In applications where separate power sources are used to drive V_{DD} and the signal inputs, the V_{DD} current capability should exceed V_{DD}/R_L (R_L = effective external load). This provision avoids permanent current flow or clamp action on the V_{DD} supply when power is applied or removed from the CD40x7B.

When switching from one address to another, some of the ON periods of the channels of the multiplexers will overlap momentarily, which may be objectionable in certain applications. Also, when a channel is turned on or off by an address input, there is a momentary conductive path from the channel to V_{SS} , which will dump some charge from any capacitor connected to the input or output of the channel. The inhibit input turning on a channel will similarly dump some charge to V_{SS} .

The amount of charge dumped is mostly a function of the signal level above V_{SS} . Typically, at $V_{DD}-V_{SS} = 10V$, a 100pF capacitor connected to the input or output of the channel will lose 3-4% of its voltage at the moment the channel turns on or off. This loss of voltage is essentially independent of the address or inhibit signal transition time, if the transition time is less than 1-2 μ s. When the inhibit signal turns a channel off, there is no charge dumping to V_{SS} . Rather, there is a slight rise in the channel voltage level (65mV typical) due to capacitive coupling from inhibit input to channel input or output. Address inputs also couple some voltage steps onto the channel signal levels.

In certain applications, the external load-resistor current may include both V_{DD} and signal-line components. To avoid drawing V_{DD} current when switch current flows into the transmission gate inputs, the voltage drop across the bidirectional switch must not exceed 0.8V (calculated from R_{TON} values shown in *Electrical Characteristics* tables). No V_{DD} current will flow through R_L if the switch current flows into terminal 1 on the CD4067B, terminals 1 and 17 on the CD4097B.

8.2 Typical Application

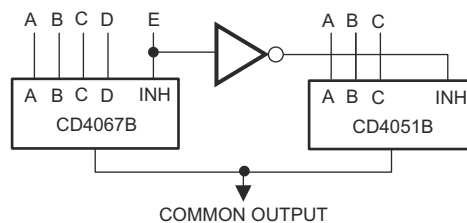

Figure 8-1. 18-24-to-1 MUX Addressing

9 Device and Documentation Support

9.1 Receiving Notification of Documentation Updates

To receive notification of documentation updates, navigate to the device product folder on ti.com. Click on *Notifications* to register and receive a weekly digest of any product information that has changed. For change details, review the revision history included in any revised document.

9.2 Support Resources

[TI E2E™ support forums](#) are an engineer's go-to source for fast, verified answers and design help — straight from the experts. Search existing answers or ask your own question to get the quick design help you need.

Linked content is provided "AS IS" by the respective contributors. They do not constitute TI specifications and do not necessarily reflect TI's views; see TI's [Terms of Use](#).

9.3 Trademarks

TI E2E™ is a trademark of Texas Instruments.
All trademarks are the property of their respective owners.

9.4 Electrostatic Discharge Caution



This integrated circuit can be damaged by ESD. Texas Instruments recommends that all integrated circuits be handled with appropriate precautions. Failure to observe proper handling and installation procedures can cause damage.

ESD damage can range from subtle performance degradation to complete device failure. Precision integrated circuits may be more susceptible to damage because very small parametric changes could cause the device not to meet its published specifications.

9.5 Glossary

[TI Glossary](#) This glossary lists and explains terms, acronyms, and definitions.

10 Revision History

NOTE: Page numbers for previous revisions may differ from page numbers in the current version.

Changes from Revision B (June 2003) to Revision C (July 2024)	Page
• Updated the numbering format for tables, figures, and cross-references throughout the document.....	1
• Changed max and typ IDD for lower supply voltages.....	6
• Changed max IIN at low temperature.....	6

11 Mechanical, Packaging, and Orderable Information

The following pages include mechanical, packaging, and orderable information. This information is the most current data available for the designated devices. This data is subject to change without notice and revision of this document. For browser-based versions of this data sheet, refer to the left-hand navigation.

PACKAGING INFORMATION

Orderable Device	Status (1)	Package Type	Package Drawing	Pins	Package Qty	Eco Plan (2)	Lead finish/ Ball material (6)	MSL Peak Temp (3)	Op Temp (°C)	Device Marking (4/5)	Samples
CD4067BF	ACTIVE	CDIP	J	24	15	Non-RoHS & Non-Green	Call TI	N / A for Pkg Type	-55 to 125	CD4067BF	Samples
CD4067BF3A	ACTIVE	CDIP	J	24	15	Non-RoHS & Non-Green	Call TI	N / A for Pkg Type	-55 to 125	CD4067BF3A	Samples
CD4067BM96	ACTIVE	SOIC	DW	24	2000	RoHS & Green	NIPDAU SN	Level-1-260C-UNLIM	-55 to 125	CD4067BM	Samples
CD4067BPWR	ACTIVE	TSSOP	PW	24	2000	RoHS & Green	NIPDAU	Level-1-260C-UNLIM	-55 to 125	CM067B	Samples
CD4097BF	ACTIVE	CDIP	J	24	15	Non-RoHS & Non-Green	Call TI	N / A for Pkg Type	-55 to 125	CD4097BF	Samples
CD4097BM	NRND	SOIC	DW	24	25	RoHS & Green	NIPDAU	Level-1-260C-UNLIM	-55 to 125	CD4097BM	
CD4097BME4	NRND	SOIC	DW	24	25	RoHS & Green	NIPDAU	Level-1-260C-UNLIM	-55 to 125	CD4097BM	
CD4097BMG4	NRND	SOIC	DW	24	25	RoHS & Green	NIPDAU	Level-1-260C-UNLIM	-55 to 125	CD4097BM	
CD4097BPW	NRND	TSSOP	PW	24	60	RoHS & Green	NIPDAU	Level-1-260C-UNLIM	-55 to 125	CM097B	
CD4097BPWR	NRND	TSSOP	PW	24	2000	RoHS & Green	NIPDAU	Level-1-260C-UNLIM	-55 to 125	CM097B	
CD4097BPWRE4	NRND	TSSOP	PW	24	2000	RoHS & Green	NIPDAU	Level-1-260C-UNLIM	-55 to 125	CM097B	

(1) The marketing status values are defined as follows:

ACTIVE: Product device recommended for new designs.

LIFEBUY: TI has announced that the device will be discontinued, and a lifetime-buy period is in effect.

NRND: Not recommended for new designs. Device is in production to support existing customers, but TI does not recommend using this part in a new design.

PREVIEW: Device has been announced but is not in production. Samples may or may not be available.

OBSELETE: TI has discontinued the production of the device.

(2) **RoHS:** TI defines "RoHS" to mean semiconductor products that are compliant with the current EU RoHS requirements for all 10 RoHS substances, including the requirement that RoHS substance do not exceed 0.1% by weight in homogeneous materials. Where designed to be soldered at high temperatures, "RoHS" products are suitable for use in specified lead-free processes. TI may reference these types of products as "Pb-Free".

RoHS Exempt: TI defines "RoHS Exempt" to mean products that contain lead but are compliant with EU RoHS pursuant to a specific EU RoHS exemption.

Green: TI defines "Green" to mean the content of Chlorine (Cl) and Bromine (Br) based flame retardants meet JS709B low halogen requirements of <=1000ppm threshold. Antimony trioxide based flame retardants must also meet the <=1000ppm threshold requirement.

(3) MSL, Peak Temp. - The Moisture Sensitivity Level rating according to the JEDEC industry standard classifications, and peak solder temperature.

(4) There may be additional marking, which relates to the logo, the lot trace code information, or the environmental category on the device.

⁽⁵⁾ Multiple Device Markings will be inside parentheses. Only one Device Marking contained in parentheses and separated by a "~" will appear on a device. If a line is indented then it is a continuation of the previous line and the two combined represent the entire Device Marking for that device.

⁽⁶⁾ Lead finish/Ball material - Orderable Devices may have multiple material finish options. Finish options are separated by a vertical ruled line. Lead finish/Ball material values may wrap to two lines if the finish value exceeds the maximum column width.

Important Information and Disclaimer:The information provided on this page represents TI's knowledge and belief as of the date that it is provided. TI bases its knowledge and belief on information provided by third parties, and makes no representation or warranty as to the accuracy of such information. Efforts are underway to better integrate information from third parties. TI has taken and continues to take reasonable steps to provide representative and accurate information but may not have conducted destructive testing or chemical analysis on incoming materials and chemicals. TI and TI suppliers consider certain information to be proprietary, and thus CAS numbers and other limited information may not be available for release.

In no event shall TI's liability arising out of such information exceed the total purchase price of the TI part(s) at issue in this document sold by TI to Customer on an annual basis.

OTHER QUALIFIED VERSIONS OF CD4067B, CD4067B-MIL, CD4097B, CD4097B-MIL :

- Catalog : [CD4067B](#), [CD4097B](#)
- Military : [CD4067B-MIL](#), [CD4097B-MIL](#)

NOTE: Qualified Version Definitions:

- Catalog - TI's standard catalog product
- Military - QML certified for Military and Defense Applications

TAPE AND REEL INFORMATION

QUADRANT ASSIGNMENTS FOR PIN 1 ORIENTATION IN TAPE

*All dimensions are nominal

Device	Package Type	Package Drawing	Pins	SPQ	Reel Diameter (mm)	Reel Width W1 (mm)	A0 (mm)	B0 (mm)	K0 (mm)	P1 (mm)	W (mm)	Pin1 Quadrant
CD4067BM96	SOIC	DW	24	2000	330.0	24.4	10.75	15.7	2.7	12.0	24.0	Q1
CD4067BM96G4	SOIC	DW	24	2000	330.0	24.4	10.75	15.7	2.7	12.0	24.0	Q1
CD4067BPWR	TSSOP	PW	24	2000	330.0	16.4	6.95	8.3	1.6	8.0	16.0	Q1
CD4097BPWR	TSSOP	PW	24	2000	330.0	16.4	6.95	8.3	1.6	8.0	16.0	Q1

TAPE AND REEL BOX DIMENSIONS

*All dimensions are nominal

Device	Package Type	Package Drawing	Pins	SPQ	Length (mm)	Width (mm)	Height (mm)
CD4067BM96	SOIC	DW	24	2000	350.0	350.0	43.0
CD4067BM96G4	SOIC	DW	24	2000	350.0	350.0	43.0
CD4067BPWR	TSSOP	PW	24	2000	356.0	356.0	35.0
CD4097BPWR	TSSOP	PW	24	2000	356.0	356.0	35.0

TUBE

*All dimensions are nominal

Device	Package Name	Package Type	Pins	SPQ	L (mm)	W (mm)	T (μm)	B (mm)
CD4067BM	DW	SOIC	24	25	506.98	12.7	4826	6.6
CD4067BPW	PW	TSSOP	24	60	530	10.2	3600	3.5
CD4067BPWG4	PW	TSSOP	24	60	530	10.2	3600	3.5
CD4097BM	DW	SOIC	24	25	506.98	12.7	4826	6.6
CD4097BME4	DW	SOIC	24	25	506.98	12.7	4826	6.6
CD4097BMG4	DW	SOIC	24	25	506.98	12.7	4826	6.6
CD4097BPW	PW	TSSOP	24	60	530	10.2	3600	3.5

DW (R-PDSO-G24)

PLASTIC SMALL OUTLINE

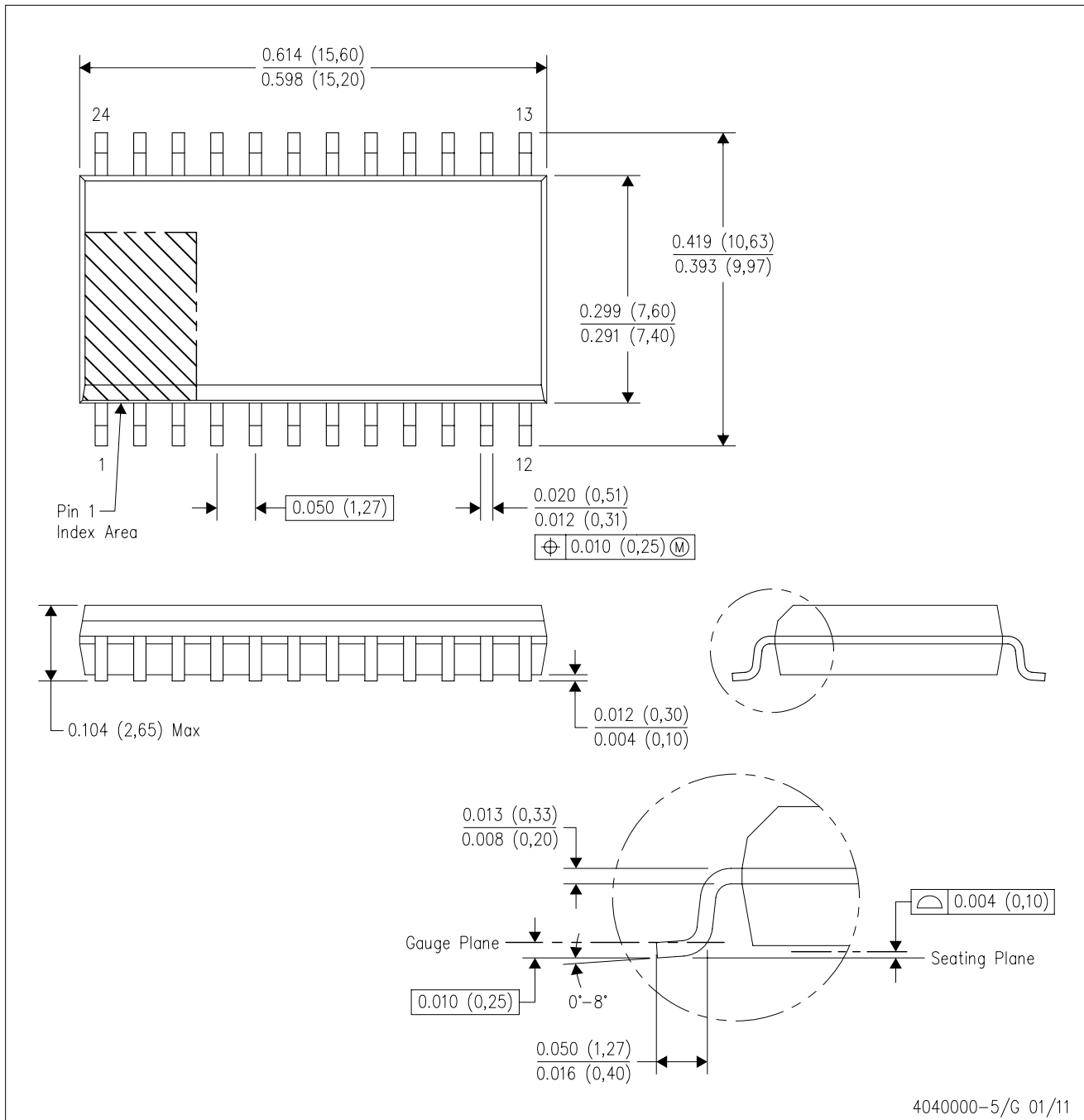

- NOTES:
- A. All linear dimensions are in inches (millimeters). Dimensioning and tolerancing per ASME Y14.5M-1994.
 - B. This drawing is subject to change without notice.
 - C. Body dimensions do not include mold flash or protrusion not to exceed 0.006 (0,15).
 - D. Falls within JEDEC MS-013 variation AD.

DW (R-PDSO-G24)

PLASTIC SMALL OUTLINE

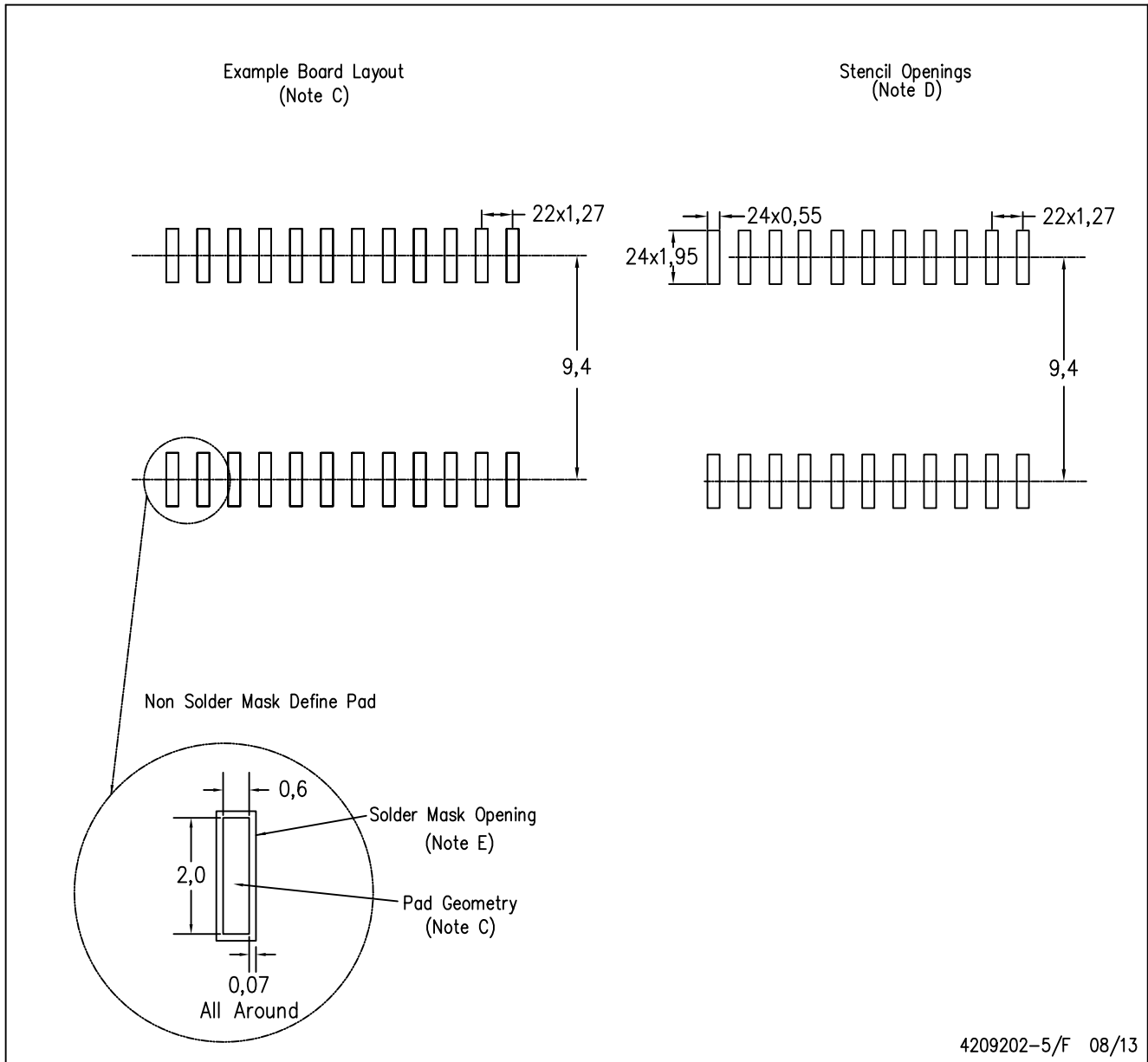

- NOTES:
- A. All linear dimensions are in millimeters.
 - B. This drawing is subject to change without notice.
 - C. Refer to IPC7351 for alternate board design.
 - D. Laser cutting apertures with trapezoidal walls and also rounding corners will offer better paste release. Customers should contact their board assembly site for stencil design recommendations. Refer to IPC-7525
 - E. Customers should contact their board fabrication site for solder mask tolerances between and around signal pads.

J (R-GDIP-T**)

CERAMIC DUAL-IN-LINE PACKAGE

24 PINS SHOWN

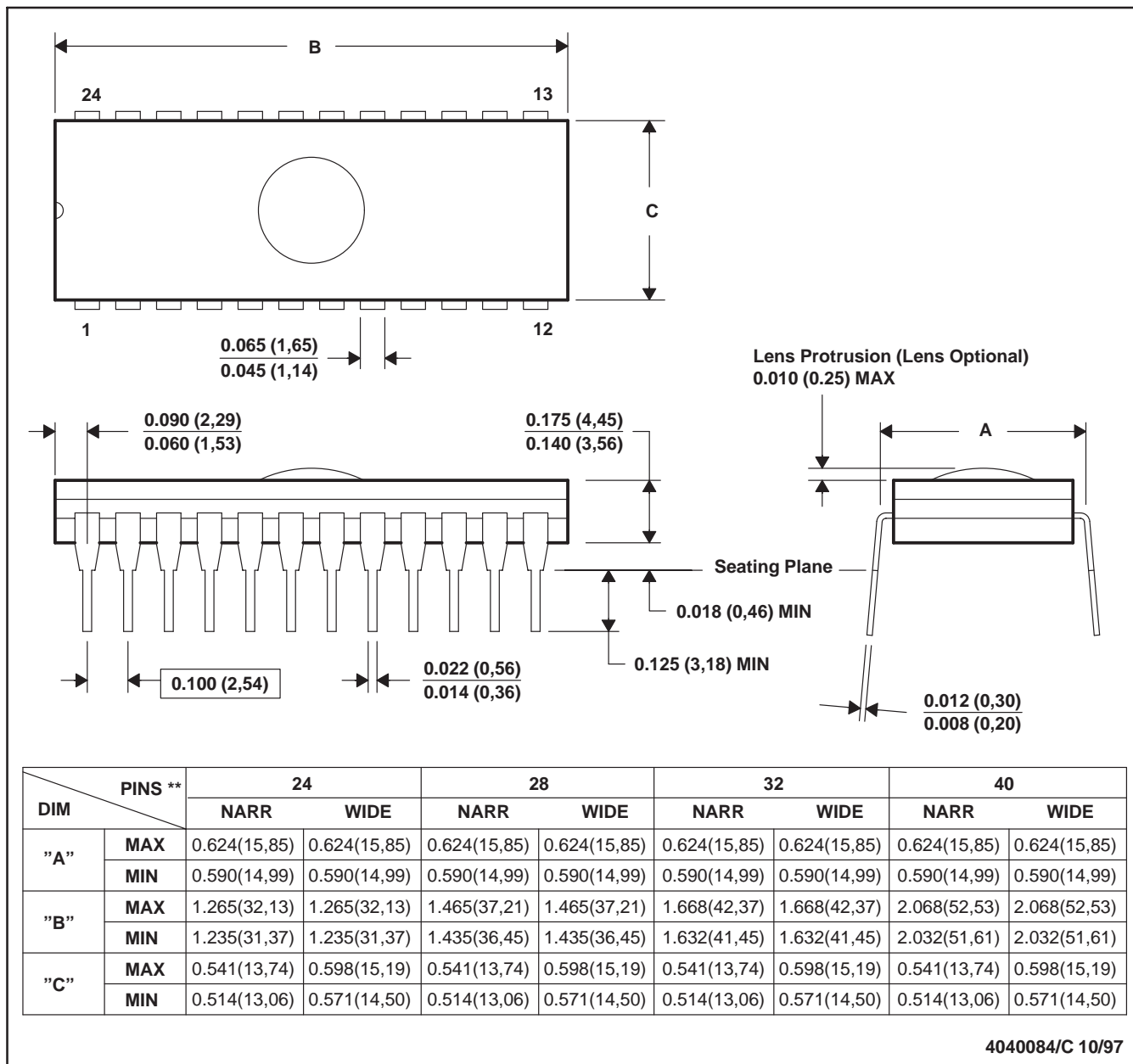

- NOTES: A. All linear dimensions are in inches (millimeters).
 B. This drawing is subject to change without notice.
 C. Window (lens) added to this group of packages (24-, 28-, 32-, 40-pin).
 D. This package can be hermetically sealed with a ceramic lid using glass frit.
 E. Index point is provided on cap for terminal identification.

PW0024A

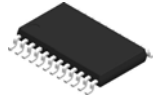

PACKAGE OUTLINE

TSSOP - 1.2 mm max height

SMALL OUTLINE PACKAGE

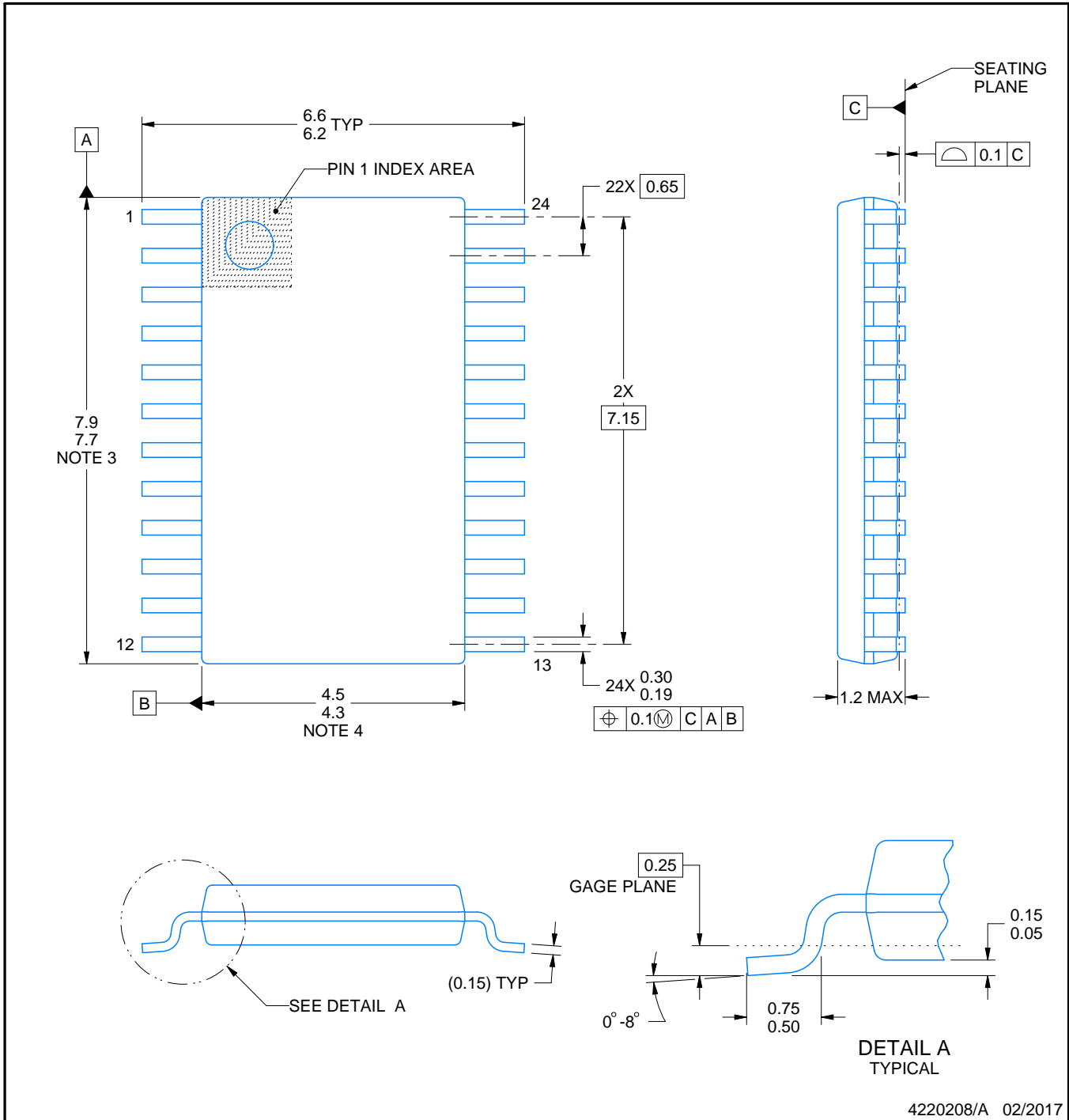

4220208/A 02/2017

NOTES:

1. All linear dimensions are in millimeters. Any dimensions in parenthesis are for reference only. Dimensioning and tolerancing per ASME Y14.5M.
2. This drawing is subject to change without notice.
3. This dimension does not include mold flash, protrusions, or gate burrs. Mold flash, protrusions, or gate burrs shall not exceed 0.15 mm per side.
4. This dimension does not include interlead flash. Interlead flash shall not exceed 0.25 mm per side.
5. Reference JEDEC registration MO-153.

EXAMPLE BOARD LAYOUT

PW0024A

TSSOP - 1.2 mm max height

SMALL OUTLINE PACKAGE

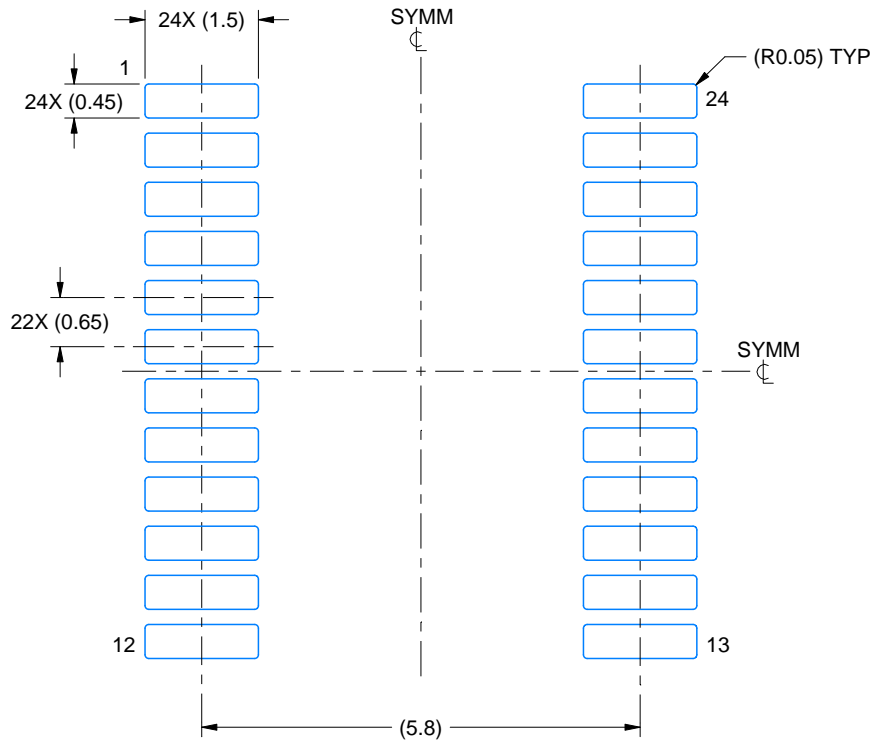

LAND PATTERN EXAMPLE
EXPOSED METAL SHOWN
SCALE: 10X

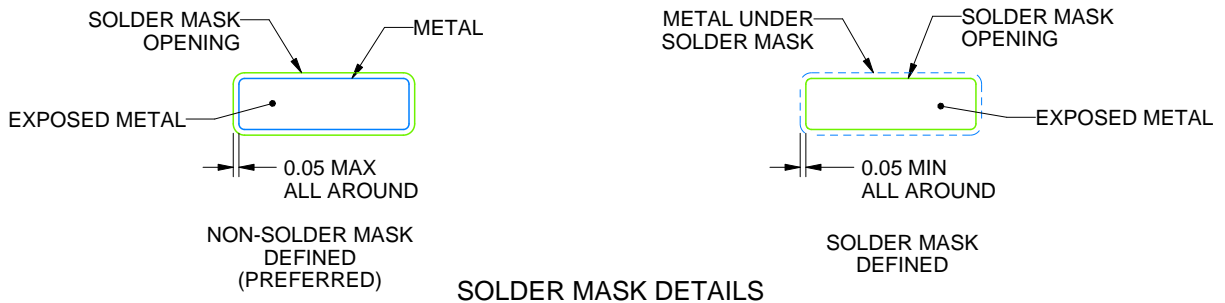

SOLDER MASK DETAILS

4220208/A 02/2017

NOTES: (continued)

- 6. Publication IPC-7351 may have alternate designs.
- 7. Solder mask tolerances between and around signal pads can vary based on board fabrication site.

EXAMPLE STENCIL DESIGN

PW0024A

TSSOP - 1.2 mm max height

SMALL OUTLINE PACKAGE

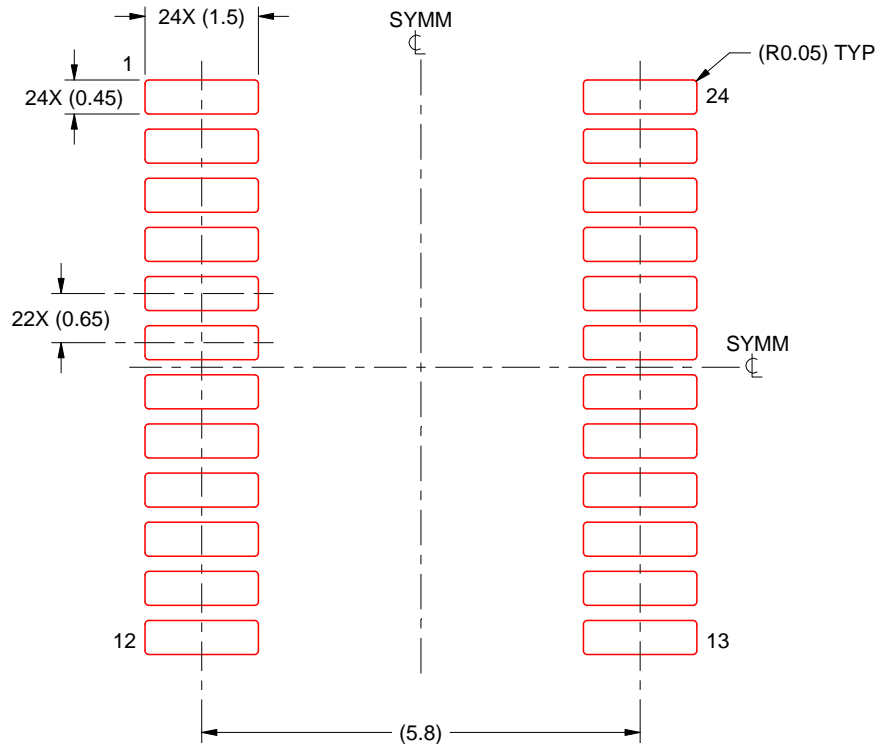

SOLDER PASTE EXAMPLE
BASED ON 0.125 mm THICK STENCIL
SCALE: 10X

4220208/A 02/2017

NOTES: (continued)

8. Laser cutting apertures with trapezoidal walls and rounded corners may offer better paste release. IPC-7525 may have alternate design recommendations.
9. Board assembly site may have different recommendations for stencil design.

IMPORTANT NOTICE AND DISCLAIMER

TI PROVIDES TECHNICAL AND RELIABILITY DATA (INCLUDING DATA SHEETS), DESIGN RESOURCES (INCLUDING REFERENCE DESIGNS), APPLICATION OR OTHER DESIGN ADVICE, WEB TOOLS, SAFETY INFORMATION, AND OTHER RESOURCES "AS IS" AND WITH ALL FAULTS, AND DISCLAIMS ALL WARRANTIES, EXPRESS AND IMPLIED, INCLUDING WITHOUT LIMITATION ANY IMPLIED WARRANTIES OF MERCHANTABILITY, FITNESS FOR A PARTICULAR PURPOSE OR NON-INFRINGEMENT OF THIRD PARTY INTELLECTUAL PROPERTY RIGHTS.

These resources are intended for skilled developers designing with TI products. You are solely responsible for (1) selecting the appropriate TI products for your application, (2) designing, validating and testing your application, and (3) ensuring your application meets applicable standards, and any other safety, security, regulatory or other requirements.

These resources are subject to change without notice. TI grants you permission to use these resources only for development of an application that uses the TI products described in the resource. Other reproduction and display of these resources is prohibited. No license is granted to any other TI intellectual property right or to any third party intellectual property right. TI disclaims responsibility for, and you will fully indemnify TI and its representatives against, any claims, damages, costs, losses, and liabilities arising out of your use of these resources.

TI's products are provided subject to [TI's Terms of Sale](#) or other applicable terms available either on [ti.com](https://www.ti.com) or provided in conjunction with such TI products. TI's provision of these resources does not expand or otherwise alter TI's applicable warranties or warranty disclaimers for TI products.

TI objects to and rejects any additional or different terms you may have proposed.

Mailing Address: Texas Instruments, Post Office Box 655303, Dallas, Texas 75265
Copyright © 2024, Texas Instruments Incorporated

Looking for pricing, stock, or lifecycle information?

Click below to explore more details on WIN SOURCE:

 [View CD4097BF](#) on WIN SOURCE

 [Texas Instruments](#) Information

Optimize Your Supply Chain with WIN SOURCE Solutions

-  Global Sourcing Solution
-  Obsolete Management
-  Cost Control Management
-  Shortage Management
-  Alternative Solution
-  Excess Inventory Management