



**THE DATASHEET OF  
STH210N75F6-2**





# STH210N75F6-2

N-channel 75 V, 2.7 mΩ typ., 180 A STripFET™ VI DeepGATE™ Power MOSFET in H<sup>2</sup>PAK-2 package

Datasheet — production data

## Features

Order code	V <sub>DSS</sub>	R <sub>DS(on)</sub> max	I <sub>D</sub>
STH210N75F6-2	75 V	< 3.4 mΩ	180 A

- Low gate charge
- Very low on-resistance
- High avalanche ruggedness

## Applications

- Switching applications

## Description

This device is an N-channel Power MOSFET developed using the 6<sup>th</sup> generation of STripFET™ DeepGATE™ technology, with a new gate structure. The resulting Power MOSFET exhibits the lowest R<sub>DS(on)</sub> in all packages.

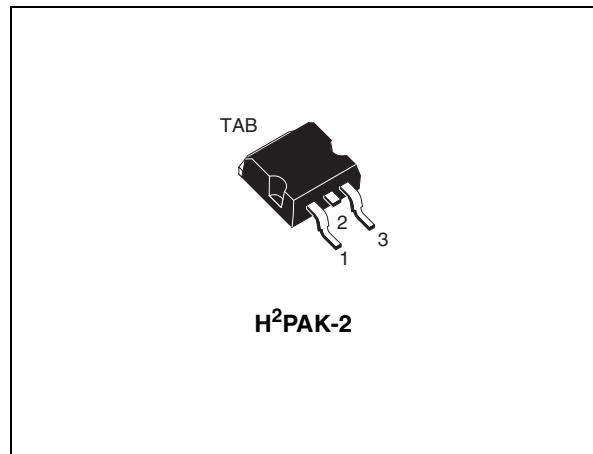

Figure 1. Internal schematic diagram

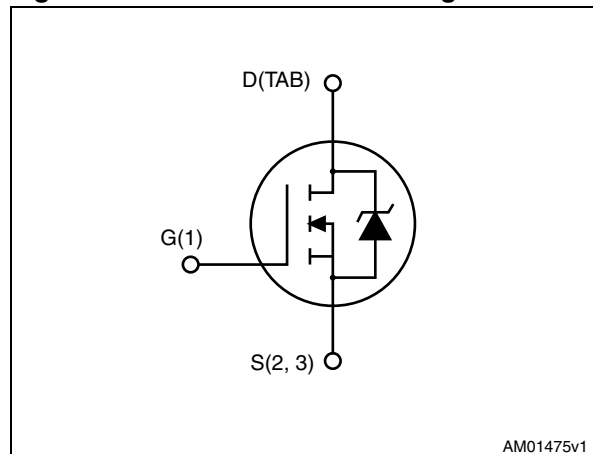

Table 1. Device summary

Order code	Marking	Package	Packaging
STH210N75F6-2	210N75F6	H <sup>2</sup> PAK-2	Tape and reel

## Contents

<b>1</b>	<b>Electrical ratings</b> .....	<b>3</b>
<b>2</b>	<b>Electrical characteristics</b> .....	<b>4</b>
2.1	Electrical characteristics (curves) .....	6
<b>3</b>	<b>Test circuits</b> .....	<b>8</b>
<b>4</b>	<b>Package mechanical data</b> .....	<b>9</b>
<b>5</b>	<b>Packaging mechanical data</b> .....	<b>13</b>
<b>6</b>	<b>Revision history</b> .....	<b>15</b>

# 1 Electrical ratings

**Table 2. Absolute maximum ratings**

Symbol	Parameter	Value	Unit
$V_{DS}$	Drain-source voltage	75	V
$V_{GS}$	Gate-source voltage	$\pm 20$	V
$I_D$	Drain current (continuous) at $T_C = 25\text{ }^\circ\text{C}$	180	A
$I_D$	Drain current (continuous) at $T_C = 100\text{ }^\circ\text{C}$	150	A
$I_{DM}^{(1)}$	Drain current (pulsed)	720	A
$P_{TOT}$	Total dissipation at $T_C = 25\text{ }^\circ\text{C}$	300	W
$E_{AS}^{(2)}$	Single pulse avalanche energy	540	mJ
	Derating factor	2	W/ $^\circ\text{C}$
$T_{stg}$	Storage temperature	- 55 to 175	$^\circ\text{C}$
$T_j$	Operating junction temperature		

1. Current limited by package.
2. Starting  $T_j = 25\text{ }^\circ\text{C}$ ,  $I_D = 60\text{ A}$ ,  $V_{DD} = 50\text{ V}$ .

**Table 3. Thermal data**

Symbol	Parameter	Value	Unit
$R_{thj-case}$	Thermal resistance junction-case max	0.5	$^\circ\text{C}/\text{W}$
$R_{thj-pcb}^{(1)}$	Thermal resistance junction-pcb max	35	$^\circ\text{C}/\text{W}$

1. When mounted on FR-4 board of 1 inch<sup>2</sup>, 2 oz Cu.

## 2 Electrical characteristics

( $T_{CASE} = 25\text{ °C}$  unless otherwise specified)

**Table 4. On/off states**

Symbol	Parameter	Test conditions	Min.	Typ.	Max.	Unit
$V_{(BR)DSS}$	Drain-source breakdown voltage ( $V_{GS} = 0$ )	$I_D = 250\ \mu A$	75			V
$I_{DSS}$	Zero gate voltage drain current ( $V_{GS} = 0$ )	$V_{DS} = 75\text{ V}$ $V_{DS} = 75\text{ V}, T_C = 125\text{ °C}$			1 100	$\mu A$ $\mu A$
$I_{GSS}$	Gate-body leakage current ( $V_{DS} = 0$ )	$V_{GS} = \pm 20\text{ V}$			$\pm 100$	nA
$V_{GS(th)}$	Gate threshold voltage	$V_{DS} = V_{GS}, I_D = 250\ \mu A$	2		4	V
$R_{DS(on)}$	Static drain-source on-resistance	$V_{GS} = 10\text{ V}, I_D = 90\text{ A}$		2.7	3.4	m $\Omega$

**Table 5. Dynamic**

Symbol	Parameter	Test conditions	Min.	Typ.	Max.	Unit
$C_{iss}$	Input capacitance			11800		pF
$C_{oss}$	Output capacitance	$V_{DS} = 25\text{ V}, f = 1\text{ MHz},$ $V_{GS} = 0$	-	1060	-	pF
$C_{rss}$	Reverse transfer capacitance			394		pF
$Q_g$	Total gate charge	$V_{DD} = 37.5\text{ V}, I_D = 120\text{ A},$ $V_{GS} = 10\text{ V}$		171		nC
$Q_{gs}$	Gate-source charge	$V_{GS} = 10\text{ V}$ <i>(see Figure 14)</i>	-	50	-	nC
$Q_{gd}$	Gate-drain charge			36		nC

**Table 6. Switching times**

Symbol	Parameter	Test conditions	Min.	Typ.	Max.	Unit
$t_{d(on)}$	Turn-on delay time	$V_{DD} = 40\text{ V}, I_D = 60\text{ A}$ $R_G = 4.7\ \Omega, V_{GS} = 10\text{ V}$ <i>(see Figure 13)</i>	-	34	-	ns
$t_r$	Rise time		-	70	-	ns
$t_{d(off)}$	Turn-off-delay time	$V_{DD} = 40\text{ V}, I_D = 60\text{ A}$ $R_G = 4.7\ \Omega, V_{GS} = 10\text{ V}$ <i>(see Figure 13)</i>	-	154	-	ns
$t_f$	Fall time		-	71	-	ns

**Table 7. Source drain diode**

Symbol	Parameter	Test conditions	Min.	Typ.	Max	Unit
$I_{SD}$	Source-drain current		-		180	A
$I_{SDM}^{(1)}$	Source-drain current (pulsed)		-		720	A
$V_{SD}^{(2)}$	Forward on voltage	$I_{SD} = 180 \text{ A}, V_{GS} = 0$	-		1.5	V
$t_{rr}$ $Q_{rr}$ $I_{RRM}$	Reverse recovery time Reverse recovery charge Reverse recovery current	$I_{SD} = 120 \text{ A}, V_{DD} = 60 \text{ V}$ $di/dt = 100 \text{ A}/\mu\text{s}$ , $T_j = 150 \text{ }^\circ\text{C}$ <i>(see Figure 15)</i>	-	60 144 4.8		ns nC A

1. Current limited by package.
2. Pulsed: pulse duration = 300  $\mu\text{s}$ , duty cycle 1.5%

## 2.1 Electrical characteristics (curves)

Figure 2. Safe operating area

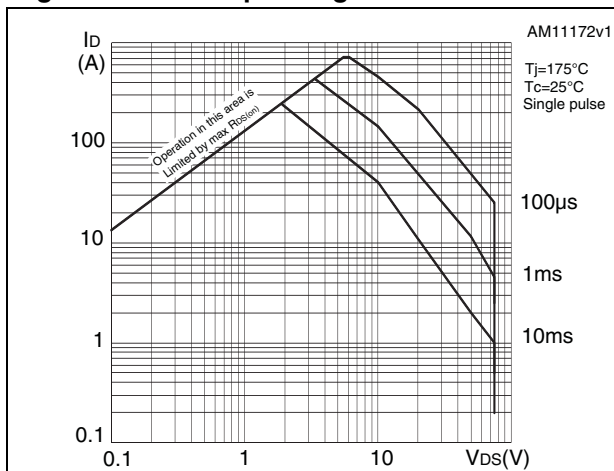

Figure 3. Thermal impedance

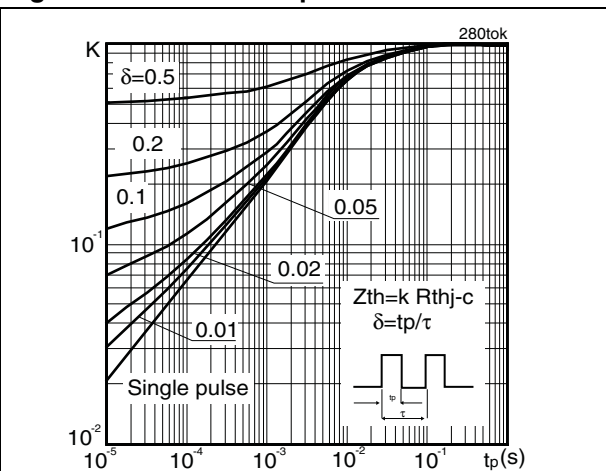

Figure 4. Output characteristics

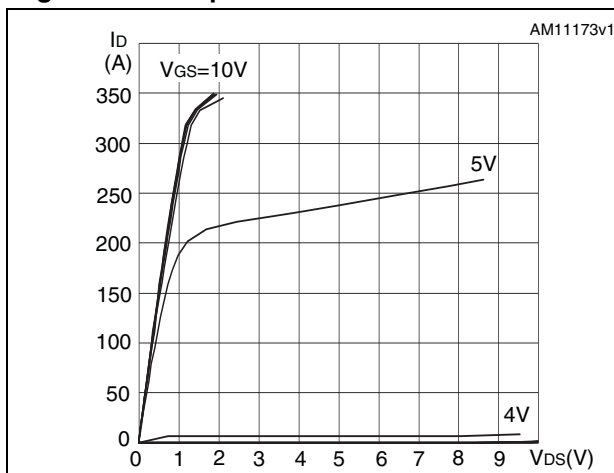

Figure 5. Transfer characteristics

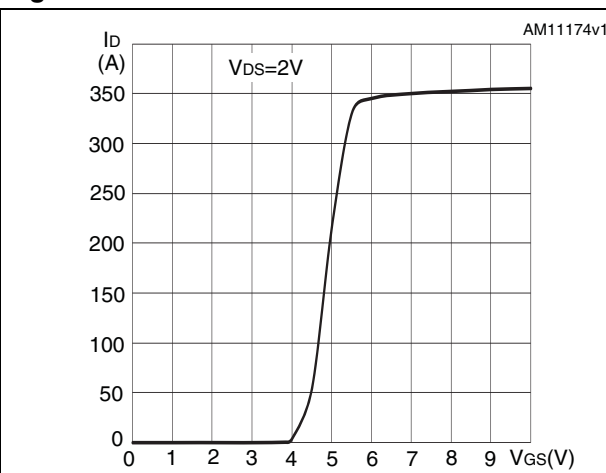

Figure 6. Normalized V<sub>DS</sub> vs temperature

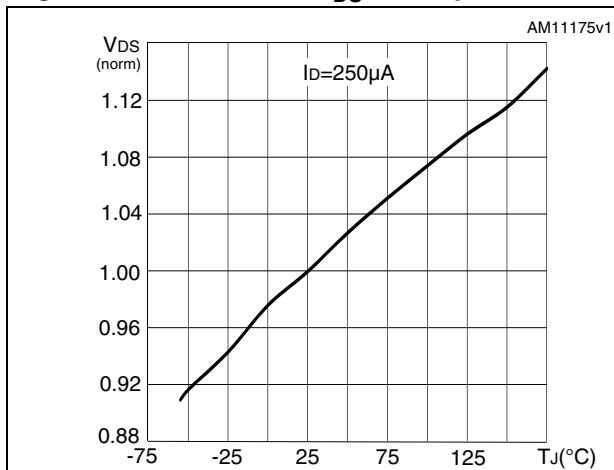

Figure 7. Static drain-source on-resistance

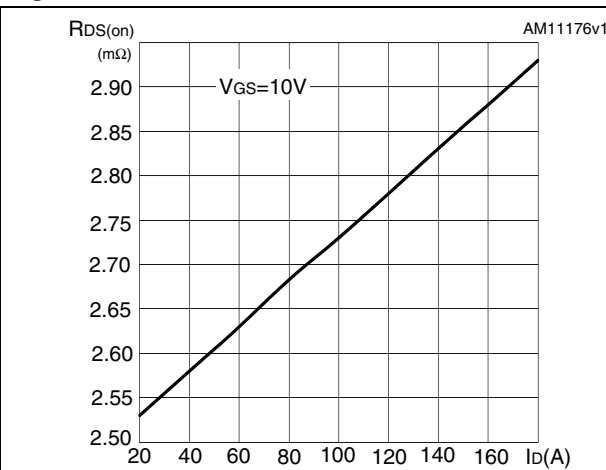

Figure 8. Gate charge vs gate-source voltage Figure 9. Capacitance variations

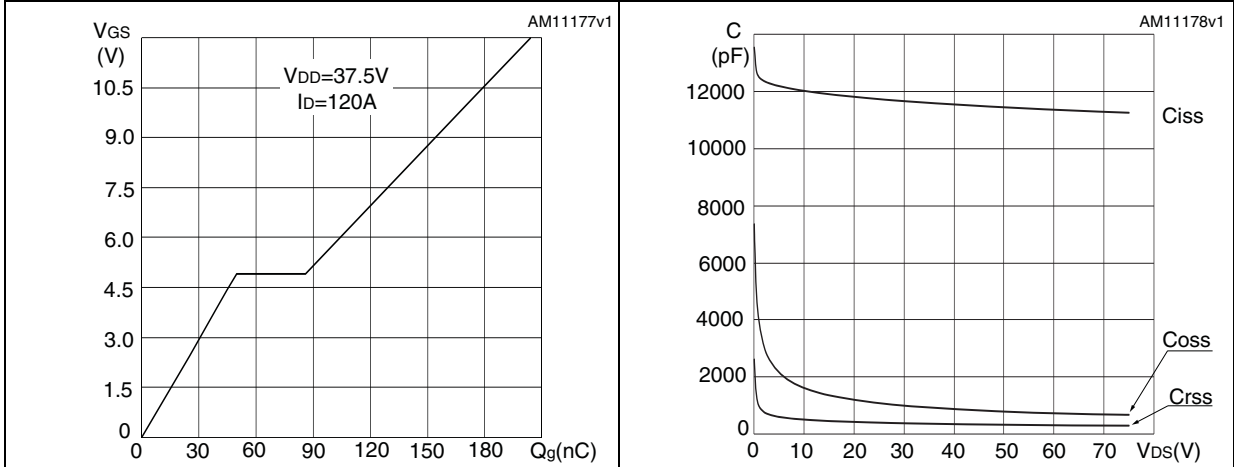

Figure 10. Normalized gate threshold voltage vs temperature Figure 11. Normalized on-resistance vs temperature

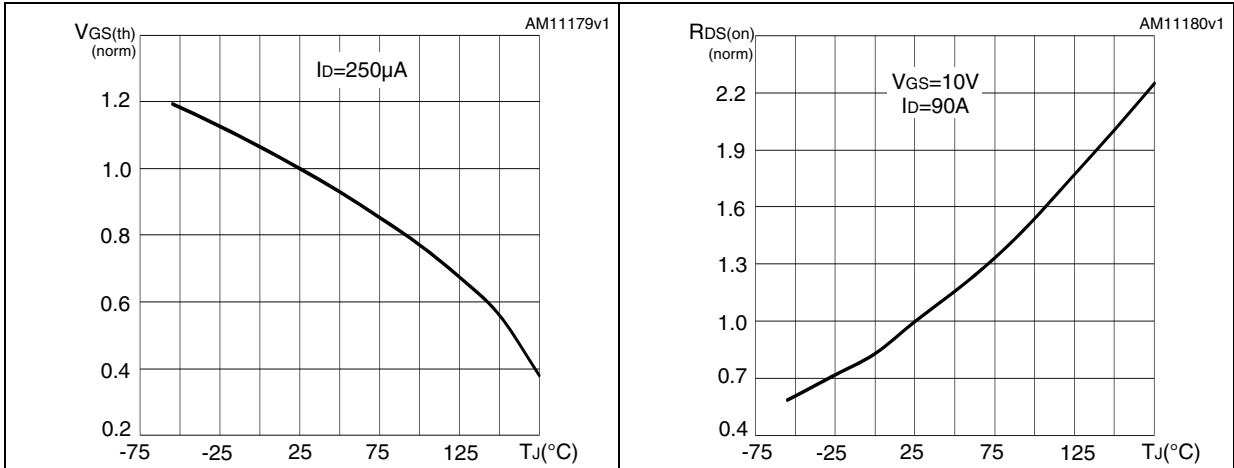
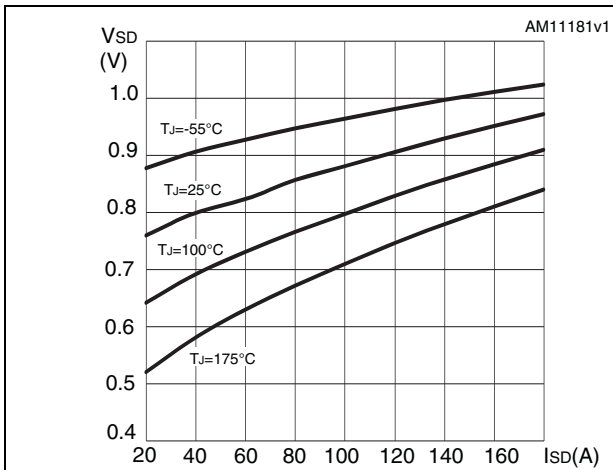

Figure 12. Source-drain diode forward characteristics





## 4 Package mechanical data

In order to meet environmental requirements, ST offers these devices in different grades of ECOPACK<sup>®</sup> packages, depending on their level of environmental compliance. ECOPACK<sup>®</sup> specifications, grade definitions and product status are available at: [www.st.com](http://www.st.com). ECOPACK is an ST trademark.

Table 8. H<sup>2</sup>PAK-2 mechanical data

Dim.	mm		
	Min.	Typ.	Max.
A	4.30		4.80
A1	0.03		0.20
C	1.17		1.37
e	4.98		5.18
E	0.50		0.90
F	0.78		0.85
H	10.00		10.40
H1	7.40		7.80
L	15.30		15.80
L1	1.27		1.40
L2	4.93		5.23
L3	6.85		7.25
L4	1.5		1.7
M	2.6		2.9
R	0.20		0.60
V	0°		8°

Figure 19. H<sup>2</sup>PAK-2 drawing

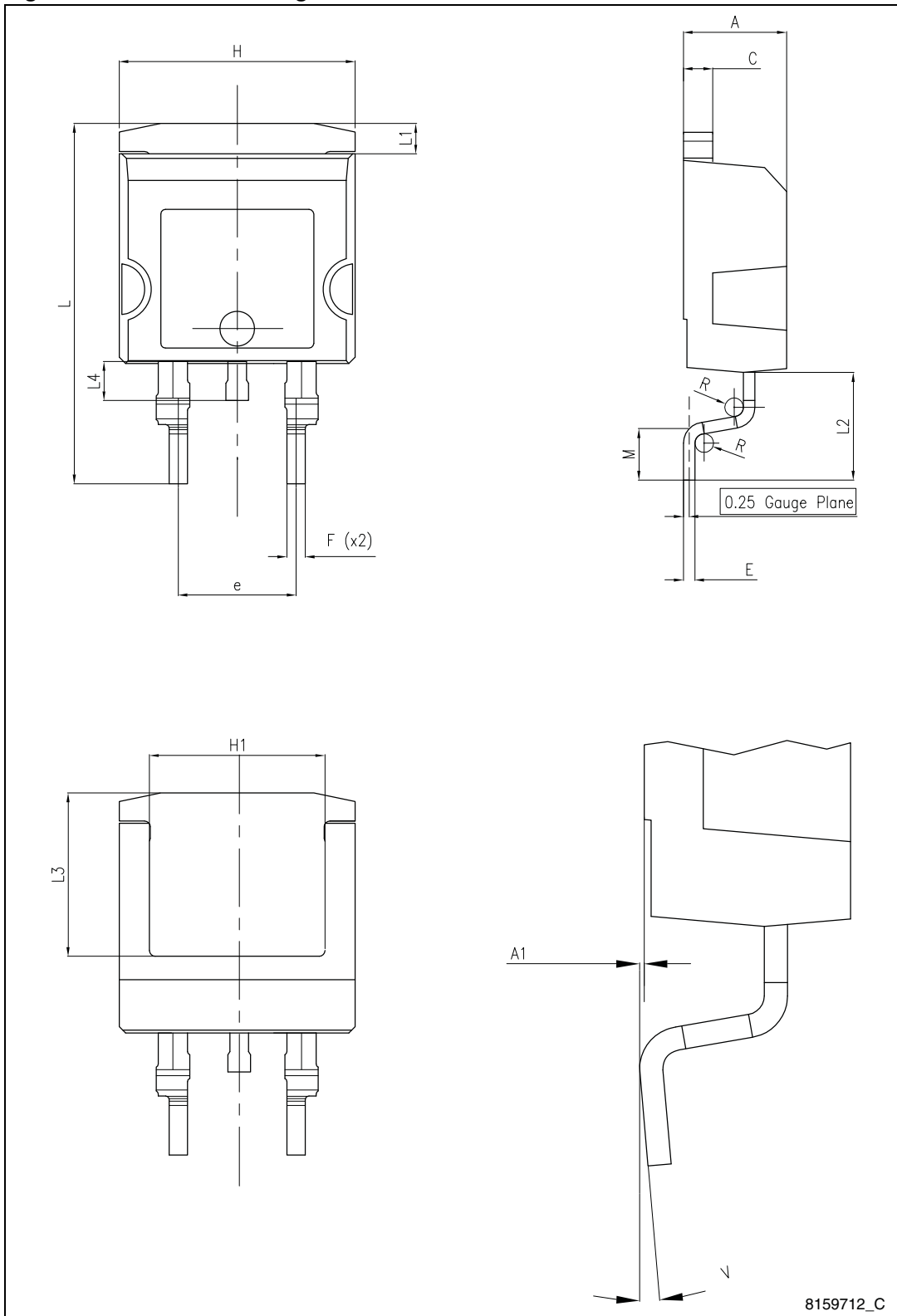
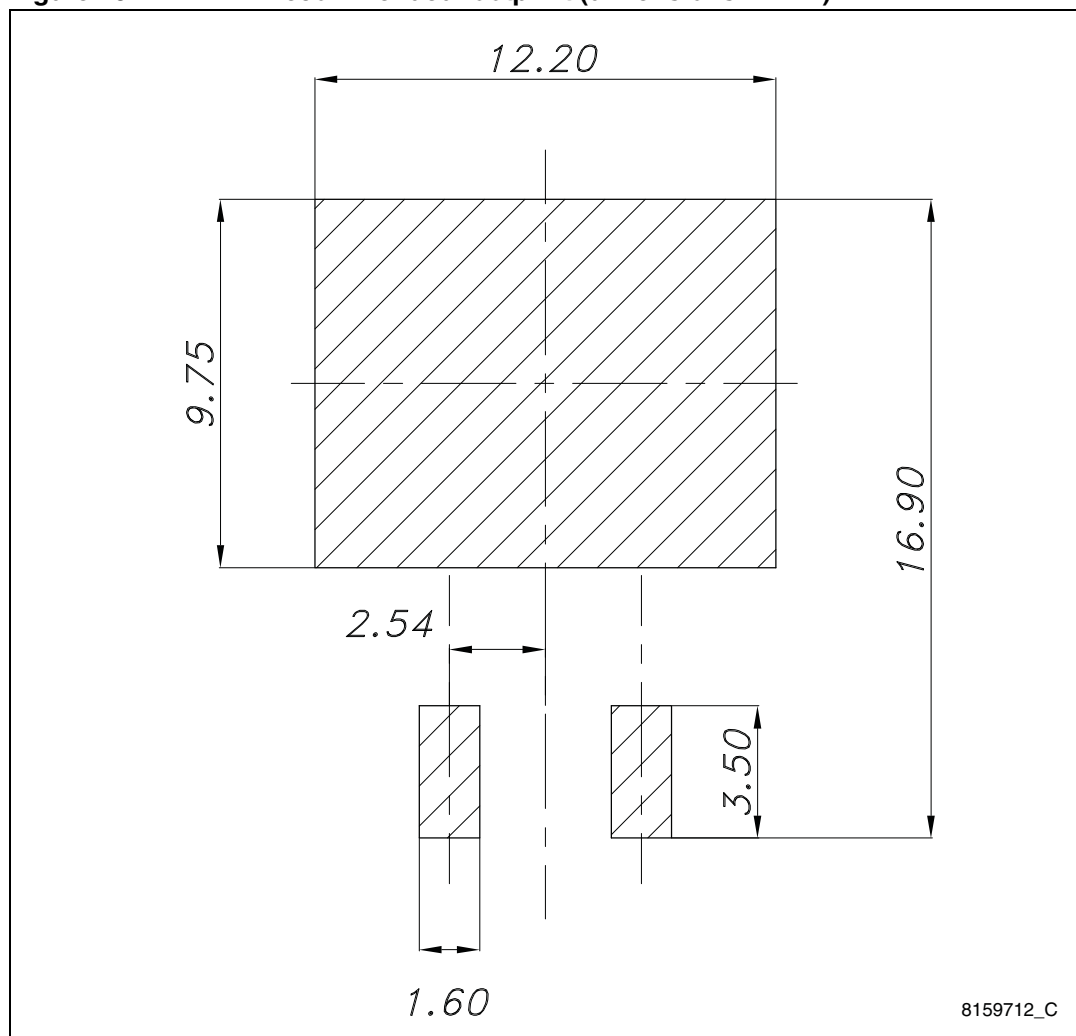

Figure 20. H<sup>2</sup>PAK-2 recommended footprint (dimensions in mm)



8159712\_C

## 5 Packaging mechanical data

Table 9. H<sup>2</sup>PAK-2 tape and reel mechanical data

Tape			Reel		
Dim.	mm		Dim.	mm	
	Min.	Max.		Min.	Max.
A0	10.5	10.7	A		330
B0	15.7	15.9	B	1.5	
D	1.5	1.6	C	12.8	13.2
D1	1.59	1.61	D	20.2	
E	1.65	1.85	G	24.4	26.4
F	11.4	11.6	N	100	
K0	4.8	5.0	T		30.4
P0	3.9	4.1			
P1	11.9	12.1	Base qty		1000
P2	1.9	2.1	Bulk qty		1000
R	50				
T	0.25	0.35			
W	23.7	24.3			

Figure 21. Tape

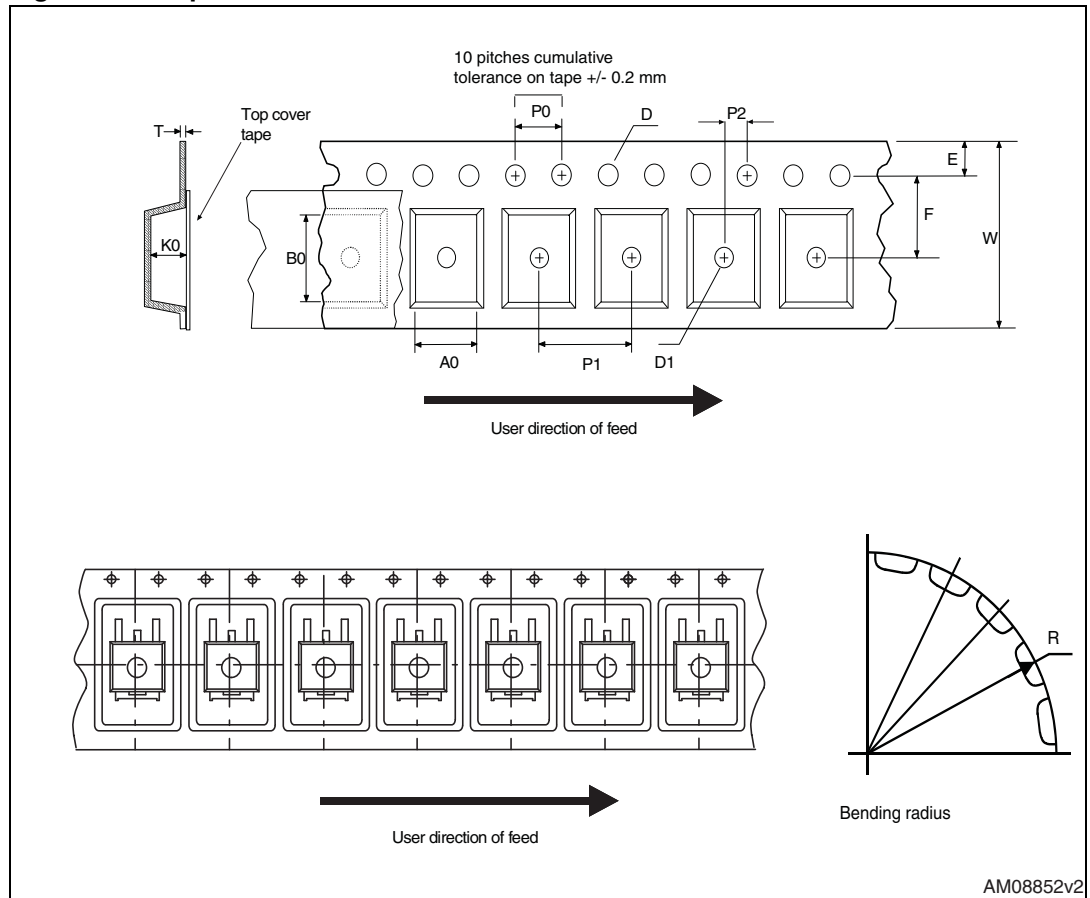

AM08852v2

Figure 22. Reel

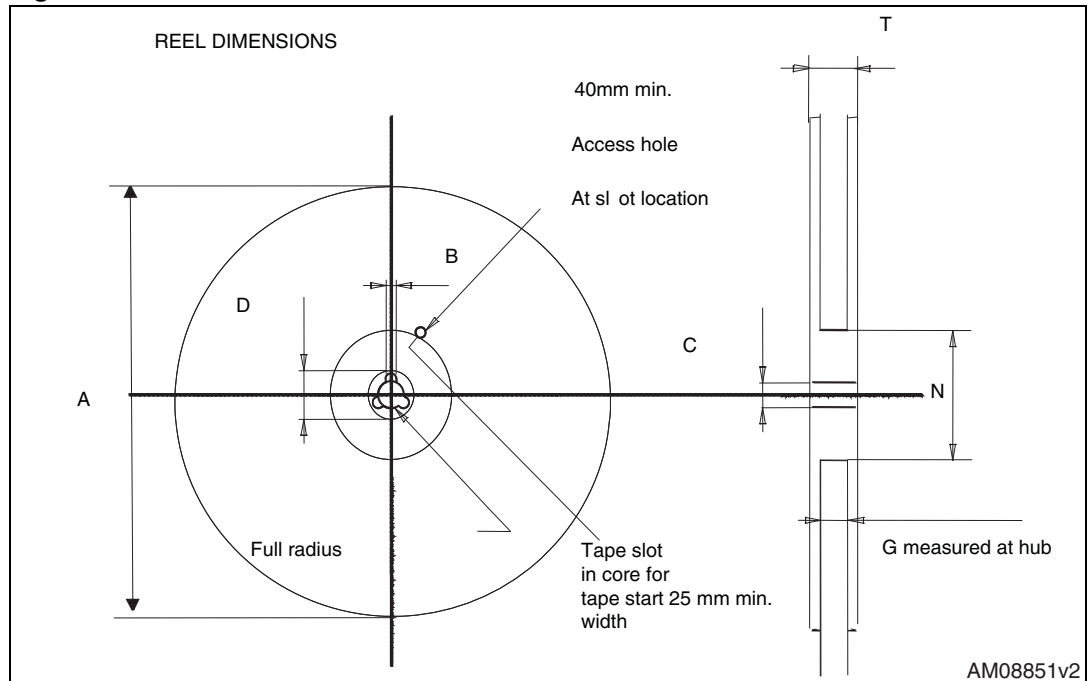

AM08851v2

## 6 Revision history

Table 10. Document revision history

Date	Revision	Changes
23-May-2011	1	First release.
20-Jul-2012	2	Document status promoted from preliminary data to datasheet. Updated mechanical data. Inserted <a href="#">Section 2.1: Electrical characteristics (curves)</a> . Inserted <a href="#">Section 5: Packaging mechanical data</a> .

**Please Read Carefully:**

Information in this document is provided solely in connection with ST products. STMicroelectronics NV and its subsidiaries ("ST") reserve the right to make changes, corrections, modifications or improvements, to this document, and the products and services described herein at any time, without notice.

All ST products are sold pursuant to ST's terms and conditions of sale.

Purchasers are solely responsible for the choice, selection and use of the ST products and services described herein, and ST assumes no liability whatsoever relating to the choice, selection or use of the ST products and services described herein.

No license, express or implied, by estoppel or otherwise, to any intellectual property rights is granted under this document. If any part of this document refers to any third party products or services it shall not be deemed a license grant by ST for the use of such third party products or services, or any intellectual property contained therein or considered as a warranty covering the use in any manner whatsoever of such third party products or services or any intellectual property contained therein.

**UNLESS OTHERWISE SET FORTH IN ST'S TERMS AND CONDITIONS OF SALE ST DISCLAIMS ANY EXPRESS OR IMPLIED WARRANTY WITH RESPECT TO THE USE AND/OR SALE OF ST PRODUCTS INCLUDING WITHOUT LIMITATION IMPLIED WARRANTIES OF MERCHANTABILITY, FITNESS FOR A PARTICULAR PURPOSE (AND THEIR EQUIVALENTS UNDER THE LAWS OF ANY JURISDICTION), OR INFRINGEMENT OF ANY PATENT, COPYRIGHT OR OTHER INTELLECTUAL PROPERTY RIGHT.**

**UNLESS EXPRESSLY APPROVED IN WRITING BY TWO AUTHORIZED ST REPRESENTATIVES, ST PRODUCTS ARE NOT RECOMMENDED, AUTHORIZED OR WARRANTED FOR USE IN MILITARY, AIR CRAFT, SPACE, LIFE SAVING, OR LIFE SUSTAINING APPLICATIONS, NOR IN PRODUCTS OR SYSTEMS WHERE FAILURE OR MALFUNCTION MAY RESULT IN PERSONAL INJURY, DEATH, OR SEVERE PROPERTY OR ENVIRONMENTAL DAMAGE. ST PRODUCTS WHICH ARE NOT SPECIFIED AS "AUTOMOTIVE GRADE" MAY ONLY BE USED IN AUTOMOTIVE APPLICATIONS AT USER'S OWN RISK.**

Resale of ST products with provisions different from the statements and/or technical features set forth in this document shall immediately void any warranty granted by ST for the ST product or service described herein and shall not create or extend in any manner whatsoever, any liability of ST.

ST and the ST logo are trademarks or registered trademarks of ST in various countries.

Information in this document supersedes and replaces all information previously supplied.

The ST logo is a registered trademark of STMicroelectronics. All other names are the property of their respective owners.

© 2012 STMicroelectronics - All rights reserved

STMicroelectronics group of companies

Australia - Belgium - Brazil - Canada - China - Czech Republic - Finland - France - Germany - Hong Kong - India - Israel - Italy - Japan - Malaysia - Malta - Morocco - Philippines - Singapore - Spain - Sweden - Switzerland - United Kingdom - United States of America

[www.st.com](http://www.st.com)

## Looking for pricing, stock, or lifecycle information?

Click below to explore more details on WIN SOURCE:

- ⊖ [View \*\*STH210N75F6-2\*\* on WIN SOURCE](#)
- ⊖ [STMicroelectronics](#) Information

## Optimize Your Supply Chain with WIN SOURCE Solutions

- ✓ Global Sourcing Solution
- ✓ Obsolete Management
- ✓ Cost Control Management
- ✓ Shortage Management
- ✓ Alternative Solution
- ✓ Excess Inventory Management