



Independent Clock Quad HOTLink II™ Serializer

Features

- Second-generation HOTLink® technology
- Compliant to SMPTE 292M and SMPTE 259M video standards
- Quad channel video serializer
 - 195- to 1500-Mbps serial data signaling rate
 - Simultaneous operation at different signaling rates
- Supports half-rate and full-rate clocking
- Internal phase-locked loops (PLLs) with no external PLL components
- Redundant differential PECL-compatible serial outputs per channel
 - No external bias resistors required
 - Signaling-rate controlled edge-rates
 - Internal source termination
- Synchronous LVTTTL parallel interface
- JTAG boundary scan
- Built-In Self-Test (BIST) for at-speed link testing
- Low-power 2W @ 3.3V typical
- Single 3.3V supply
- Thermally enhanced BGA
- Pb-Free package option available
- 0.25µ BiCMOS technology

Functional Description

The CYV15G0403TB Independent Clock Quad HOTLink II™ Serializer is a point-to-point or point-to-multipoint communications building block enabling transfer of data over a variety of

high-speed serial links including SMPTE 292M and SMPTE 259M video applications. It supports signaling rates in the range of 195 to 1500 Mbps per serial link. All four channels are independent and can simultaneously operate at different rates. Each channel accepts 10-bit parallel characters in an Input Register and converts them to serial data. *Figure 1* illustrates typical connections between independent video coprocessors and corresponding CYV15G0403TB Serializer and CYV15G0404RB Reclocking Deserializer chips.

The CYV15G0403TB satisfies the SMPTE-259M and SMPTE-292M compliance as per SMPTE EG34-1999 Pathological Test Requirements.

As a second-generation HOTLink device, the CYV15G0403TB extends the HOTLink family with enhanced levels of integration and faster data rates, while maintaining serial-link compatibility (data and BIST) with other HOTLink devices. Each channel of the CYV15G0403TB Quad HOTLink II device independently accepts scrambled 10-bit transmission characters. These characters are serialized and output from dual Positive ECL (PECL) compatible differential transmission-line drivers at a bit-rate of either 10- or 20-times the input reference clock for that channel.

Each channel contains an independent BIST pattern generator. This BIST hardware allows at-speed testing of the high-speed serial data paths in each transmit section of this device, each receive section of a connected HOTLink II device, and across the interconnecting links.

The CYV15G0403TB is ideal for SMPTE applications where different data rates and serial interface standards are necessary for each channel. Some applications include multi-format routers, switchers, format converters, and cameras.

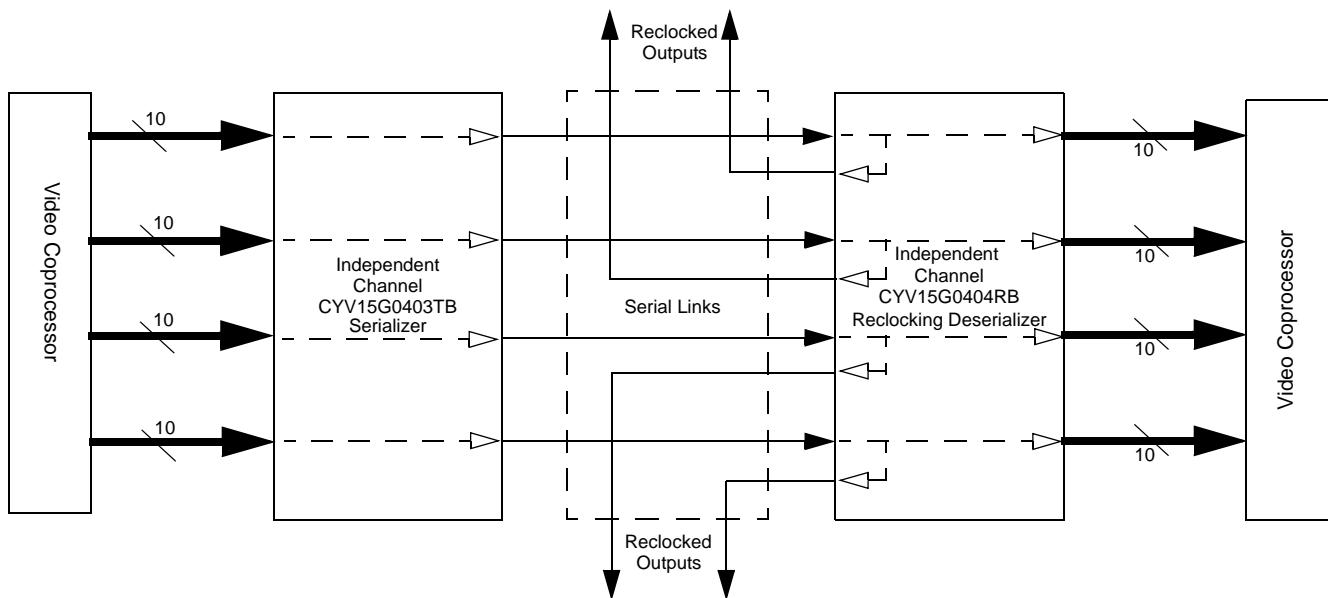
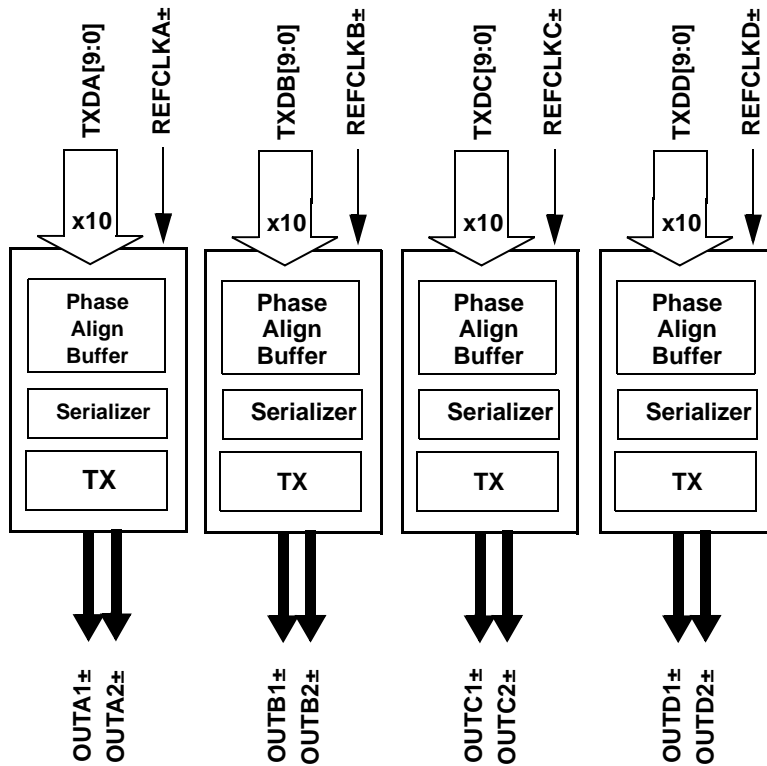
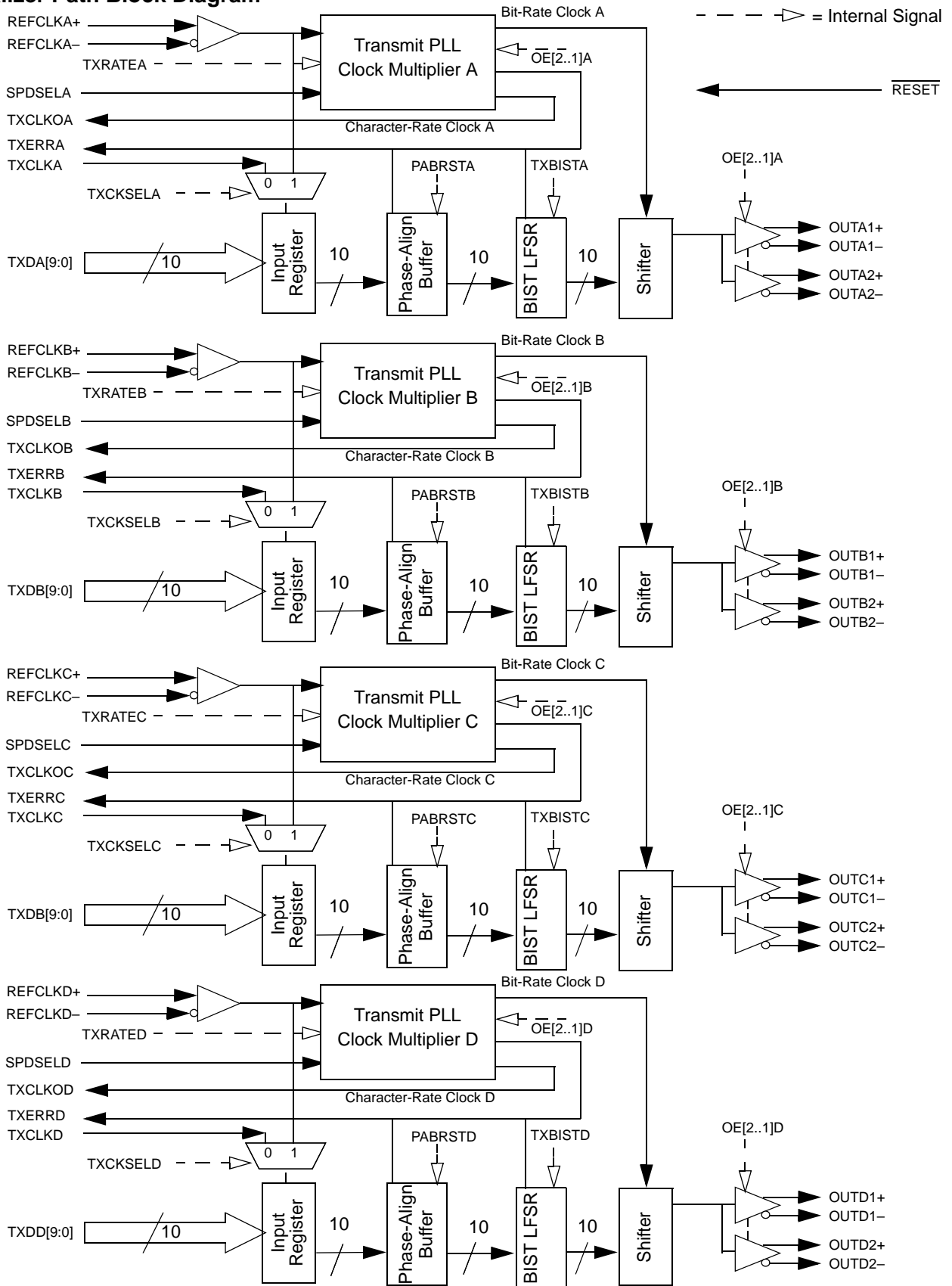
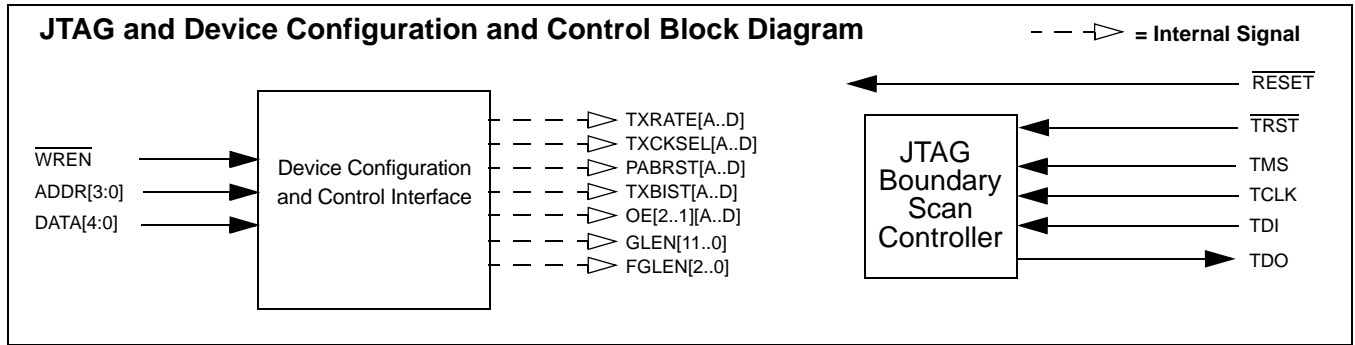

Figure 1. HOTLink II™ System Connections

CYV15G0403TB Serializer Logic Block Diagram



Serializer Path Block Diagram



Pin Configuration (Top View)^[1]

	1	2	3	4	5	6	7	8	9	10	11	12	13	14	15	16	17	18	19	20
A	NC	OUT C1-	NC	OUT C2-	V _{CC}	NC	OUT D1-	GND	GND	OUT D2-	GND	OUT A1-	GND	GND	OUT A2-	V _{CC}	V _{CC}	OUT B1-	V _{CC}	OUT B2-
B	V _{CC}	OUT C1+	V _{CC}	OUT C2+	V _{CC}	V _{CC}	OUT D1+	GND	NC	OUT D2+	NC	OUT A1+	GND	NC	OUT A2+	V _{CC}	NC	OUT B1+	NC	OUT B2+
C	TDI	TMS	V _{CC}	V _{CC}	V _{CC}	NC	NC	GND	NC	NC	DATA [3]	DATA [1]	GND	NC	SPD SELD	V _{CC}	NC	$\overline{\text{TRST}}$	GND	TDO
D	TCLK	$\overline{\text{RESET}}$	V _{CC}	V _{CC}	V _{CC}	V _{CC}	SPD SELC	GND	GND	DATA [4]	DATA [2]	DATA [0]	GND	GND	NC	V _{CC}	NC	NC	SCAN EN2	TMEN3
E	V _{CC}	V _{CC}	V _{CC}	V _{CC}													V _{CC}	V _{CC}	V _{CC}	V _{CC}
F	NC	NC	TX DC[0]	NC													NC	NC	TX CLKOB	NC
G	TX DC[7]	$\overline{\text{WREN}}$	TX DC[4]	TX DC[1]													SPD SELB	NC	SPD SELA	NC
H	GND	GND	GND	GND													GND	GND	GND	GND
J	TX DC[9]	TX DC[5]	TX DC[2]	TX DC[3]													NC	NC	NC	NC
K	NC	REF CLKC-	TX DC[8]	TX CLKC													NC	NC	NC	NC
L	NC	REF CLKC+	NC	TX DC[6]													NC	NC	NC	TX DB[6]
M	NC	NC	NC	TX ERRC													REF CLKB+	REF CLKB-	TX ERRB	TX CLKB
N	GND	GND	GND	GND													GND	GND	GND	GND
P	NC	NC	NC	NC													TX DB[5]	TX DB[4]	TX DB[3]	TX DB[2]
R	NC	TX CLKOC	NC	NC													TX DB[1]	TX DB[0]	TX DB[9]	TX DB[7]
T	V _{CC}	V _{CC}	V _{CC}	V _{CC}													V _{CC}	V _{CC}	V _{CC}	V _{CC}
U	TX DD[0]	TX DD[1]	TX DD[2]	TX DD[9]	V _{CC}	NC	NC	GND	TX DA[9]	ADDR [0]	REF CLKD-	TX DA[1]	GND	TX DA[4]	TX DA[8]	V _{CC}	NC	TX DB[8]	NC	NC
V	TX DD[3]	TX DD[4]	TX DD[8]	NC	V _{CC}	NC	NC	GND	NC	ADDR [2]	REF CLKD+	TX CLKOA	GND	TX DA[3]	TX DA[7]	V _{CC}	NC	NC	NC	NC
W	TX DD[5]	TX DD[7]	NC	NC	V _{CC}	NC	NC	GND	ADDR [3]	ADDR [1]	NC	TX ERRA	GND	TX DA[2]	TX DA[6]	V _{CC}	NC	REF CLKA+	NC	NC
Y	TX DD[6]	TX CLKD	NC	NC	V _{CC}	NC	NC	GND	TX CLKOD	NC	TX CLKA	NC	GND	TX DA[0]	TX DA[5]	V _{CC}	TX ERRD	REF CLKA-	NC	NC

Note:

1. NC = Do not connect.

Pin Configuration (Bottom View)^[1]

	20	19	18	17	16	15	14	13	12	11	10	9	8	7	6	5	4	3	2	1
A	OUT B2-	V _{CC}	OUT B1-	V _{CC}	V _{CC}	OUT A2-	GND	GND	OUT A1-	GND	OUT D2-	GND	GND	OUT D1-	NC	V _{CC}	OUT C2-	NC	OUT C1-	NC
B	OUT B2+	NC	OUT B1+	NC	V _{CC}	OUT A2+	NC	GND	OUT A1+	NC	OUT D2+	NC	GND	OUT D1+	V _{CC}	V _{CC}	OUT C2+	V _{CC}	OUT C1+	V _{CC}
C	TDO	GND	$\overline{\text{TRST}}$	NC	V _{CC}	SPD SELD	NC	GND	DATA [1]	DATA [3]	NC	NC	GND	NC	NC	V _{CC}	V _{CC}	V _{CC}	TMS	TDI
D	TMEN3	SCAN EN2	NC	NC	V _{CC}	NC	GND	GND	DATA [0]	DATA [2]	DATA [4]	GND	GND	SPD SELC	V _{CC}	V _{CC}	V _{CC}	V _{CC}	$\overline{\text{RESET}}$	TCLK
E	V _{CC}	V _{CC}	V _{CC}	V _{CC}													V _{CC}	V _{CC}	V _{CC}	V _{CC}
F	NC	TX CLKOB	NC	NC													NC	TX DC[0]	NC	NC
G	NC	SPD SELA	NC	SPD SELB													TX DC[1]	TX DC[4]	$\overline{\text{WREN}}$	TX DC[7]
H	GND	GND	GND	GND													GND	GND	GND	GND
J	NC	NC	NC	NC													TX DC[3]	TX DC[2]	TX DC[5]	TX DC[9]
K	NC	NC	NC	NC													TX CLKC	TX DC[8]	REF CLKC-	NC
L	TX DB[6]	NC	NC	NC													TX DC[6]	NC	REF CLKC+	NC
M	TX CLKB	TX ERRB	REF CLKB-	REF CLKB+													TX ERRC	NC	NC	NC
N	GND	GND	GND	GND													GND	GND	GND	GND
P	TX DB[2]	TX DB[3]	TX DB[4]	TX DB[5]													NC	NC	NC	NC
R	TX DB[7]	TX DB[9]	TX DB[0]	TX DB[1]													NC	NC	TX CLKOC	NC
T	V _{CC}	V _{CC}	V _{CC}	V _{CC}													V _{CC}	V _{CC}	V _{CC}	V _{CC}
U	NC	NC	TX DB[8]	NC	V _{CC}	TX DA[8]	TX DA[4]	GND	TX DA[1]	REF CLKD-	ADDR [0]	TX DA[9]	GND	NC	NC	V _{CC}	TX DD[9]	TX DD[2]	TX DD[1]	TX DD[0]
V	NC	NC	NC	NC	V _{CC}	TX DA[7]	TX DA[3]	GND	TX CLKOA	REF CLKD+	ADDR [2]	NC	GND	NC	NC	V _{CC}	NC	TX DD[8]	TX DD[4]	TX DD[3]
W	NC	NC	REF CLKA+	NC	V _{CC}	TX DA[6]	TX DA[2]	GND	TX ERRA	NC	ADDR [1]	ADDR [3]	GND	NC	NC	V _{CC}	NC	NC	TX DD[7]	TX DD[5]
Y	NC	NC	REF CLKA-	TX ERRD	V _{CC}	TX DA[5]	TX DA[0]	GND	NC	TX CLKA	NC	TX CLKOD	GND	NC	NC	V _{CC}	NC	NC	TX CLKD	TX DD[6]

Pin Definitions
CYV15G0403TB Quad HOTLink II Serializer

Name	I/O Characteristics	Signal Description
Transmit Path Data and Status Signals		
TXDA[9:0] TXDB[9:0] TXDC[9:0] TXDD[9:0]	LVTTTL Input, synchronous, sampled by the associated TXCLKx [↑] or REFCLKx ^{↑[2]}	Transmit Data Inputs. TXDx[9:0] data inputs are captured on the rising edge of the transmit interface clock. The transmit interface clock is selected by the TXCKSELx latch via the device configuration interface.
TXERRA TXERRB TXERRC TXERRD	LVTTTL Output, synchronous to REFCLKx ^{↑[3]} , asynchronous to transmit channel enable / disable, asynchronous to loss or return of REFCLKx [±]	Transmit Path Error. TXERRx is asserted HIGH to indicate detection of a transmit Phase-Align Buffer underflow or overflow. If an underflow or overflow condition is detected, TXERRx, for the channel in error, is asserted HIGH and remains asserted until the transmit Phase-Align Buffer is re-centered with the PABRSTx latch via the device configuration interface. When TXBISTx = 0, the BIST progress is presented on the associated TXERRx output. The TXERRx signal pulses HIGH for one transmit-character clock period to indicate a pass through the BIST sequence once every 511 character times. TXERRx is also asserted HIGH, when any of the following conditions is true: <ul style="list-style-type: none"> • The TXPLL for the associated channel is powered down. This occurs when OE2x and OE1x for a given channel are both disabled by setting OE2x = 0 and OE1x = 0. • The absence of the REFCLKx[±] signal.
Transmit Path Clock Signals		
REFCLKA [±] REFCLKB [±] REFCLKC [±] REFCLKD [±]	Differential LVPECL or single-ended LVTTTL input clock	Reference Clock. REFCLKx [±] clock inputs are used as the timing references for the associated transmit PLL. These input clocks may also be selected to clock the transmit parallel interface. When driven by a single-ended LVCMOS or LVTTTL clock source, connect the clock source to either the true or complement REFCLKx input, and leave the alternate REFCLKx input open (floating). When driven by an LVPECL clock source, the clock must be a differential clock, using both inputs.
TXCLKA TXCLKB TXCLKC TXCLKD	LVTTTL Clock Input, internal pull-down	Transmit Path Input Clock. When configuration latch TXCKSELx = 0, the associated TXCLKx input is selected as the character-rate input clock for the TXDx[9:0] input. In this mode, the TXCLKx input must be frequency-coherent to its associated TXCLKOx output clock, but may be offset in phase by any amount. Once initialized, TXCLKx is allowed to drift in phase as much as ±180 degrees. If the input phase of TXCLKx drifts beyond the handling capacity of the Phase Align Buffer, TXERRx is asserted to indicate the loss of data, and remains asserted until the Phase Align Buffer is initialized. The phase of the TXCLKx input clock relative to its associated REFCLKx [±] is initialized when the configuration latch PABRSTx is written as 0. When the associated TXERRx is deasserted, the Phase Align Buffer is initialized and input characters are correctly captured.
TXCLKOA TXCLKOB TXCLKOC TXCLKOD	LVTTTL Output	Transmit Clock Output. TXCLKOx output clock is synthesized by each channel's transmit PLL and operates synchronous to the internal transmit character clock. TXCLKOx operates at either the same frequency as REFCLKx [±] (TXRATEx = 0), or at twice the frequency of REFCLKx [±] (TXRATEx = 1). The transmit clock outputs have no fixed phase relationship to REFCLKx [±] .
Device Control Signals		
RESET	LVTTTL Input, asynchronous, internal pull-up	Asynchronous Device Reset. RESET initializes all state machines, counters, and configuration latches in the device to a known state. RESET must be asserted LOW for a minimum pulse width. When the reset is removed, all state machines, counters and configuration latches are at an initial state. See <i>Table 2</i> for the initialize values of the device configuration latches.
SPDSELA SPDSELB SPDSELC SPDSELD	3-Level Select ^[4] static control input	Serial Rate Select. The SPDSELx inputs specify the operating signaling-rate range of each channel's PLL. LOW = 195–400 MBd MID = 400–800 MBd HIGH = 800–1500 MBd.

Notes:

2. When REFCLKx[±] is configured for half-rate operation, these inputs are sampled relative to both the rising and falling edges of the associated REFCLKx[±].
3. When REFCLKx[±] is configured for half-rate operation, these outputs are presented relative to both the rising and falling edges of the associated REFCLKx[±].
4. 3-Level Select inputs are used for static configuration. These are ternary inputs that make use of logic levels of LOW, MID, and HIGH. The LOW level is usually implemented by direct connection to V_{SS} (ground). The HIGH level is usually implemented by direct connection to V_{CC} (power). The MID level is usually implemented by not connecting the input (left floating), which allows it to self bias to the proper level.

Pin Definitions (continued)
CYV15G0403TB Quad HOTLink II Serializer

Name	I/O Characteristics	Signal Description
Device Configuration and Control Bus Signals		
WREN	LVTTL input, asynchronous, internal pull-up	Control Write Enable. The WREN input writes the values of the DATA[4:0] bus into the latch specified by the address location on the ADDR[3:0] bus. ^[5]
ADDR[3:0]	LVTTL input asynchronous, internal pull-up	Control Addressing Bus. The ADDR[3:0] bus is the input address bus used to configure the device. The WREN input writes the values of the DATA[4:0] bus into the latch specified by the address location on the ADDR[3:0] bus. ^[5] <i>Table 2</i> lists the configuration latches within the device, and the initialization value of the latches upon the assertion of RESET. <i>Table 3</i> shows how the latches are mapped in the device.
DATA[4:0]	LVTTL input asynchronous, internal pull-up	Control Data Bus. The DATA[4:0] bus is the input data bus used to configure the device. The WREN input writes the values of the DATA[4:0] bus into the latch specified by address location on the ADDR[3:0] bus. ^[5] <i>Table 2</i> lists the configuration latches within the device, and the initialization value of the latches upon the assertion of RESET. <i>Table 3</i> shows how the latches are mapped in the device.
Internal Device Configuration Latches		
TXCKSEL[A..D]	Internal Latch ^[6]	Transmit Clock Select.
TXRATE[A..D]	Internal Latch ^[6]	Transmit PLL Clock Rate Select.
TXBIST[A..D]	Internal Latch ^[6]	Transmit Bist Disabled.
OE2[A..D]	Internal Latch ^[6]	Differential Serial Output Driver 2 Enable.
OE1[A..D]	Internal Latch ^[6]	Differential Serial Output Driver 1 Enable.
PABRST[A..D]	Internal Latch ^[6]	Transmit Clock Phase Alignment Buffer Reset.
GLEN[11..0]	Internal Latch ^[6]	Global Latch Enable.
FGLEN[2..0]	Internal Latch ^[6]	Force Global Latch Enable.
Factory Test Modes		
SCANEN2	LVTTL input, internal pull-down	Factory Test 2. SCANEN2 input is for factory testing only. This input may be left as a NO CONNECT, or GND only.
TMEN3	LVTTL input, internal pull-down	Factory Test 3. TMEN3 input is for factory testing only. This input may be left as a NO CONNECT, or GND only.
Analog I/O		
OUTA1± OUTB1± OUTC1± OUTD1±	CML Differential Output	Primary Differential Serial Data Output. The OUTx1± PECL-compatible CML outputs (+3.3V referenced) are capable of driving terminated transmission lines or standard fiber-optic transmitter modules, and must be AC-coupled for PECL-compatible connections.
OUTA2± OUTB2± OUTC2± OUTD2±	CML Differential Output	Secondary Differential Serial Data Output. The OUTx2± PECL-compatible CML outputs (+3.3V referenced) are capable of driving terminated transmission lines or standard fiber-optic transmitter modules, and must be AC-coupled for PECL-compatible connections.
JTAG Interface		
TMS	LVTTL Input, internal pull-up	Test Mode Select. Used to control access to the JTAG Test Modes. If maintained high for ≥5 TCLK cycles, the JTAG test controller is reset.
TCLK	LVTTL Input, internal pull-down	JTAG Test Clock.
TDO	3-State LVTTL Output	Test Data Out. JTAG data output buffer. High-Z while JTAG test mode is not selected.
TDI	LVTTL Input, internal pull-up	Test Data In. JTAG data input port.

Notes:

- See *Device Configuration and Control Interface* for detailed information on the operation of the Configuration Interface.
- See *Device Configuration and Control Interface* for detailed information on the internal latches.

Pin Definitions (continued)

CYV15G0403TB Quad HOTLink II Serializer

Name	I/O Characteristics	Signal Description
TRST	LVTTL Input, internal pull-up	JTAG reset signal. When asserted (LOW), this input asynchronously resets the JTAG test access port controller.
Power		
V _{CC}		+3.3V Power.
GND		Signal and Power Ground for all internal circuits.

CYV15G0403TB HOTLink II Operation

The CYV15G0403TB is a highly configurable, independent clocking, quad-channel serializer designed to support reliable transfer of large quantities of digital video data, using high-speed serial links from multiple sources to multiple destinations. This device supports four 10-bit channels.

CYV15G0403TB Transmit Data Path
Input Register

The parallel input bus TXDx[9:0] can be clocked in using TXCLKx (TXCKSELx = 0) or REFCLKx (TXCKSELx = 1).

Phase-Align Buffer

Data from each Input Register is passed to the associated Phase-Align Buffer, when the TXDx[9:0] input registers are clocked using TXCLKx (TXCKSELx = 0 and TXRATEx = 0). When the TXDx[9:0] input registers are clocked using REFCLKx± (TXCKSELx = 1) and REFCLKx± is a full-rate clock, the associated Phase Alignment Buffer in the transmit path is bypassed. These buffers are used to absorb clock phase differences between the TXCLKx input clock and the internal character clock for that channel.

Once initialized, TXCLKx is allowed to drift in phase as much as ±180 degrees. If the input phase of TXCLKx drifts beyond the handling capacity of the Phase Align Buffer, TXERRx is asserted to indicate the loss of data, and remains asserted until the Phase Align Buffer is initialized. The phase of the TXCLKx relative to its associated internal character rate clock is initialized when the configuration latch PABRSTx is written as 0. When the associated TXERRx is deasserted, the Phase Align Buffer is initialized and input characters are correctly captured.

If the phase offset, between the initialized location of the input clock and REFCLKx, exceeds the skew handling capabilities of the Phase-Align Buffer, an error is reported on that channel's TXERRx output. This output indicates an error continuously until the Phase-Align Buffer for that channel is reset. While the error remains active, the transmitter for that channel outputs a continuous "1001111000" character (LSB first) to indicate to the remote receiver that an error condition is present in the link.

Transmit BIST

Each channel contains an internal pattern generator that can be used to validate both the link and device operation. These generators are enabled by the associated TXBISTx latch via the device configuration interface. When enabled, a register in the associated channel becomes a signature pattern generator by logically converting to a Linear Feedback Shift Register (LFSR). This LFSR generates a 511-character

sequence. This provides a predictable yet pseudo-random sequence that can be matched to an identical LFSR in the attached Receiver(s).

A device reset ($\overline{\text{RESET}}$ sampled LOW) presets the BIST Enable Latches to disable BIST on all channels.

All data present at the associated TXDx[9:0] inputs are ignored when BIST is active on that channel.

Transmit PLL Clock Multiplier

Each Transmit PLL Clock Multiplier accepts a character-rate or half-character-rate external clock at the associated REFCLKx± input, and that clock is multiplied by 10 or 20 (as selected by TXRATEx) to generate a bit-rate clock for use by the transmit shifter. It also provides a character-rate clock used by the transmit paths, and outputs this character rate clock as TXCLKOx.

Each clock multiplier PLL can accept a REFCLKx± input between 19.5 MHz and 150 MHz, however, this clock range is limited by the operating mode of the CYV15G0403TB clock multiplier (TXRATEx) and by the level on the associated SPDSELx input.

SPDSELx are 3-level select^[4] inputs that select one of three operating ranges for the serial data outputs and inputs of the associated channel. The operating serial signaling-rate and allowable range of REFCLKx± frequencies are listed in *Table 1*.

Table 1. Operating Speed Settings

SPDSELx	TXRATEx	REFCLKx± Frequency (MHz)	Signaling Rate (Mbps)
LOW	1	reserved	195–400
	0	19.5–40	
MID (Open)	1	20–40	400–800
	0	40–80	
HIGH	1	40–75	800–1500
	0	80–150	

The REFCLKx± inputs are differential inputs with each input internally biased to 1.4V. If the REFCLKx+ input is connected to a TTL, LVTTL, or LVCMOS clock source, the input signal is recognized when it passes through the internally biased reference point. When driven by a single-ended TTL, LVTTL, or LVCMOS clock source, connect the clock source to either the true or complement REFCLKx input, and leave the alternate REFCLKx input open (floating).

When both the REFCLKx+ and REFCLKx– inputs are connected, the clock source must be a differential clock. This can either be a differential LVPECL clock that is DC-or AC-coupled or a differential LVTTL or LVCMOS clock.

By connecting the REFCLKx- input to an external voltage source, it is possible to adjust the reference point of the REFCLKx+ input for alternate logic levels. When doing so, it is necessary to ensure that the input differential crossing point remains within the parametric range supported by the input.

Serial Output Drivers

The serial output interface drivers use differential Current Mode Logic (CML) drivers to provide source-matched drivers for 50Ω transmission lines. These drivers accept data from the Transmit Shifter, which shifts the data out LSB first. These drivers have signal swings equivalent to that of standard PECL drivers, and are capable of driving AC-coupled optical modules or transmission lines.

Transmit Channels Enabled

Each driver can be enabled or disabled separately via the device configuration interface.

When a driver is disabled via the configuration interface, it is internally powered down to reduce device power. If both serial drivers for a channel are in this disabled state, the associated internal logic for that channel is also powered down. A device reset (RESET sampled LOW) disables all output drivers.

Note. When a disabled channel (i.e., both outputs disabled) is re-enabled:

- data on the serial outputs may not meet all timing specifications for up to 250 μs
- the state of the phase-align buffer cannot be guaranteed, and a phase-align reset is required if the phase-align buffer is used

Device Configuration and Control Interface

The CYV15G0403TB is highly configurable via the configuration interface. This interface allows the device to be configured globally or allows each channel to be configured independently. *Table 2* lists the configuration latches within the device including the initialization value of the latches upon the assertion of RESET. *Table 3* shows how the latches are mapped in the device. Each row in the *Table 3* maps to a 5-bit latch bank. There are 16 such write-only latch banks. When WREN = 0, the logic value in DATA[4:0] is latched to the latch bank specified by the values in ADDR[3:0]. The second column of *Table 3* specifies the channels associated with the corresponding latch bank. For example, the first three latch banks (0, 1 and 2) consist of configuration bits for channel A. The latch banks 12, 13 and 14 consist of Global configuration bits and the last latch bank (15) is the Mask latch bank that can be configured to perform bit-by-bit configuration.

Global Enable Function

The global enable function, controlled by the GLENx bits, is a feature that can be used to reduce the number of write operations needed to setup the latch banks. This function is beneficial in systems that use a common configuration in multiple channels. The GLENx bit is present in bit 0 of latch banks 0 through 11 only. Its default value (1) enables the global

update of the latch bank's contents. Setting the GLENx bit to 0 disables this functionality.

Latch Banks 12, 13, and 14 are used to load values in the related latch banks in a global manner. A write operation to latch bank 12 could do a global write to latch banks 0, 3, 6, and 9 depending on the value of GLENx in these latch banks; latch bank 13 could do a global write to latch banks 1, 4, 7 and 10; and latch banks 14 could do a global write to latch banks 2, 5, 8 and 11. The GLENx bit cannot be modified by a global write operation.

Force Global Enable Function

FGLENx forces the global update of the target latch banks, but does not change the contents of the GLENx bits. If FGLENx = 1 for the associated global channel, FGLENx forces the global update of the target latch banks.

Mask Function

An additional latch bank (15) is used as a global mask vector to control the update of the configuration latch banks on a bit-by-bit basis. A logic 1 in a bit location allows for the update of that same location of the target latch bank(s), whereas a logic 0 disables it. The reset value of this latch bank is FFh, thereby making its use optional by default. The mask latch bank is not maskable. The FGLEN functionality is not affected by the bit 0 value of the mask latch bank.

Latch Types

There are two types of latch banks: static (S) and dynamic (D). Each channel is configured by 2 static and 1 dynamic latch banks. The S type contain those settings that normally do not change for a given application, whereas the D type controls the settings that could change during the application's lifetime. The first and second rows of each channel (address numbers 0, 1, 3, 4, 6, 7, 9, and 10) are the static control latches. The third row of latches for each channel (address numbers 2, 5, 8, and 11) are the dynamic control latches that are associated with enabling dynamic functions within the device.

Latch Bank 14 is also useful for those users that do not need the latch-based programmable feature of the device. This latch bank could be used in those applications that do not need to modify the default value of the static latch banks, and that can afford a global (i.e., not independent) control of the dynamic signals. In this case, this feature becomes available when ADDR[3:0] is left unchanged with a value of "1110" and WREN is left asserted. The signals present in DATA[4:0] effectively become global control pins, and for the latch banks 2, 5, 8 and 11.

Static Latch Values

There are some latches in the table that have a static value (i.e. 1, 0, or X). The latches that have a '1' or '0' must be configured with their corresponding value each time that their associated latch bank is configured. The latches that have an 'X' are don't cares and can be configured with any value.

Table 2. Device Configuration and Control Latch Descriptions

Name	Signal Description
TXCKSELA TXCKSELB TXCKSELC TXCKSEL D	Transmit Clock Select. The initialization value of the TXCKSELx latch = 1. TXCKSELx selects the clock source used to write data into the Transmit Input Register. When TXCKSELx = 1, the associated input register TXDx[9:0] is clocked by REFCLKx \uparrow . In this mode, the phase alignment buffer in the transmit path is bypassed. When TXCKSELx = 0, the associated TXCLKx \uparrow is used to clock in the input register TXDx[9:0].
TXRATEA TXRATEB TXRATEC TXRATED	Transmit PLL Clock Rate Select. The initialization value of the TXRATEx latch = 0. TXRATEx is used to select the clock multiplier for the Transmit PLL. When TXRATEx = 0, each transmit PLL multiplies the associated REFCLKx \pm input by 10 to generate the serial bit-rate clock. When TXRATEx = 0, the TXCLKOx output clocks are full-rate clocks and follow the frequency and duty cycle of the associated REFCLKx \pm input. When TXRATEx = 1, each Transmit PLL multiplies the associated REFCLKx \pm input by 20 to generate the serial bit-rate clock. When TXRATEx = 1, the TXCLKOx output clocks are twice the frequency rate of the REFCLKx \pm input. When TXCLKSELx = 1 and TXRATEx = 1, the Transmit Data Inputs are captured using both the rising and falling edges of REFCLKx. TXRATEx = 1 and SPDSELx = LOW, is an invalid state and this combination is reserved.
TXBISTA TXBISTB TXBISTC TXBISTD	Transmit Bist Disabled. The initialization value of the TXBISTx latch = 1. TXBISTx selects if the transmit BIST is disabled or enabled. When TXBISTx = 1, the transmit BIST function is disabled. When TXBISTx = 0, the transmit BIST function is enabled.
OE2A OE2B OE2C OE2D	Secondary Differential Serial Data Output Driver Enable. The initialization value of the OE2x latch = 0. OE2x selects if the OUT2x \pm secondary differential output drivers are enabled or disabled. When OE2x = 1, the associated serial data output driver is enabled allowing data to be transmitted from the transmit shifter. When OE2x = 0, the associated serial data output driver is disabled. When a driver is disabled via the configuration interface, it is internally powered down to reduce device power. If both serial drivers for a channel are in this disabled state, the associated internal logic for that channel is also powered down. A device reset (RESET sampled LOW) disables all output drivers.
OE1A OE1B OE1C OE1D	Primary Differential Serial Data Output Driver Enable. The initialization value of the OE1x latch = 0. OE1x selects if the OUT1x \pm primary differential output drivers are enabled or disabled. When OE1x = 1, the associated serial data output driver is enabled allowing data to be transmitted from the transmit shifter. When OE1x = 0, the associated serial data output driver is disabled. When a driver is disabled via the configuration interface, it is internally powered down to reduce device power. If both serial drivers for a channel are in this disabled state, the associated internal logic for that channel is also powered down. A device reset (RESET sampled LOW) disables all output drivers.
PABRSTA PABRSTB PABRSTC PABRSTD	Transmit Clock Phase Alignment Buffer Reset. The initialization value of the PABRSTx latch = 1. The PABRSTx is used to re-center the Transmit Phase Align Buffer. When the configuration latch PABRSTx is written as a 0, the phase of the TXCLKx input clock relative to its associated REFCLKx \pm is initialized. PABRST is an asynchronous input, but is sampled by each TXCLKx \uparrow to synchronize it to the internal clock domain. PABRSTx is a self clearing latch. This eliminates the requirement of writing a 1 to complete the initialization of the Phase Alignment Buffer.
GLEN[11..0]	Global Enable. The initialization value of the GLENx latch = 1. The GLENx is used to reconfigure several channels simultaneously in applications where several channels may have the same configuration. When GLENx = 1 for a given address, that address is allowed to participate in a global configuration. When GLENx = 0 for a given address, that address is disabled from participating in a global configuration.
FGLEN[2..0]	Force Global Enable. The initialization value of the FGLENx latch is NA. The FGLENx latch forces a GLoBAL ENable no matter what the setting is on the GLENx latch. If FGLENx = 1 for the associated Global channel, FGLEN forces the global update of the target latch banks.

Device Configuration Strategy

The following is a series of ordered events needed to load the configuration latches on a per channel basis:

1. Pulse $\overline{\text{RESET}}$ Low after device power-up. This operation resets all four channels.
2. Set the static latch banks for the target channel. May be performed using a global operation, if the application permits it.
3. Set the dynamic bank of latches for the target channel. Enable the output drivers. May be performed using a global operation, if the application permits it. [Required step.]
4. Reset the Phase Alignment Buffer for the target channel. May be performed using a global operation, if the application permits it. [Optional if phase align buffer is bypassed.]

Table 3. Device Control Latch Configuration Table

ADDR	Channel	Type	DATA4	DATA3	DATA2	DATA1	DATA0	Reset Value
0 (0000b)	A	S	X	X	0	X	GLEN0	11111
1 (0001b)	A	S	X	0	TXCKSELA	TXRATEA	GLEN1	01101
2 (0010b)	A	D	TXBISTA	OE2A	OE1A	PABRSTA	GLEN2	10011
3 (0011b)	B	S	X	X	0	X	GLEN3	11111
4 (0100b)	B	S	X	0	TXCKSELB	TXRATEB	GLEN4	01101
5 (0101b)	B	D	TXBISTB	OE2B	OE1B	PABRSTB	GLEN5	10011
6 (0110b)	C	S	X	X	0	X	GLEN6	11111
7 (0111b)	C	S	X	0	TXCKSELC	TXRATEC	GLEN7	01101
8 (1000b)	C	D	TXBISTC	OE2C	OE1C	PABRSTC	GLEN8	10011
9 (1001b)	D	S	X	X	0	X	GLEN9	11111
10 (1010b)	D	S	X	0	TXCKSELD	TXRATED	GLEN10	01101
11 (1011b)	D	D	TXBISTD	OE2D	OE1D	PABRSTD	GLEN11	10011
12 (1100b)	GLOBAL	S	X	X	0	X	FGLEN0	N/A
13 (1101b)	GLOBAL	S	X	0	TXCKSELGL	TXRATEGL	FGLEN1	N/A
14 (1110b)	GLOBAL	D	TXBISTGL	OE2GL	OE1GL	PABRSTGL	FGLEN2	N/A
15 (1111b)	MASK	D	D4	D3	D2	D1	D0	11111

JTAG Support

The CYV15G0403TB contains a JTAG port to allow system level diagnosis of device interconnect. Of the available JTAG modes, boundary scan, and bypass are supported. This capability is present only on the LVTTL inputs and outputs and the REFCLKx± clock input. The high-speed serial inputs and outputs are not part of the JTAG test chain.

3-Level Select Inputs

Each 3-Level select inputs reports as two bits in the scan register. These bits report the LOW, MID, and HIGH state of the associated input as 00, 10, and 11 respectively

JTAG ID

The JTAG device ID for the CYV15G0403TB is '0C810069'x.

Maximum Ratings

Above which the useful life may be impaired. User guidelines only, not tested

Storage Temperature -65°C to +150°C
 Ambient Temperature with Power Applied..... -55°C to +125°C
 Supply Voltage to Ground Potential -0.5V to +3.8V
 DC Voltage Applied to LVTTTL Outputs in High-Z State -0.5V to $V_{CC} + 0.5V$
 Output Current into LVTTTL Outputs (LOW)..... 60 mA
 DC Input Voltage -0.5V to $V_{CC} + 0.5V$

Static Discharge Voltage..... > 2000 V (per MIL-STD-883, Method 3015)

Latch-up Current..... > 200 mA

Power-up Requirements

The CYV15G0403TB requires one power-supply. The Voltage on any input or I/O pin cannot exceed the power pin during power-up.

Operating Range

Range	Ambient Temperature	V_{CC}
Commercial	0°C to +70°C	+3.3V ±5%

CYV15G0403TB DC Electrical Characteristics

Parameter	Description	Test Conditions	Min.	Max.	Unit
LVTTTL-compatible Outputs					
V_{OHT}	Output HIGH Voltage	$I_{OH} = -4 \text{ mA}$, $V_{CC} = \text{Min.}$	2.4		V
V_{OLT}	Output LOW Voltage	$I_{OL} = 4 \text{ mA}$, $V_{CC} = \text{Min.}$		0.4	V
I_{OST}	Output Short Circuit Current	$V_{OUT} = 0V^{[7]}$, $V_{CC} = 3.3V$	-20	-100	mA
I_{OZL}	High-Z Output Leakage Current	$V_{OUT} = 0V$, V_{CC}	-20	20	µA
LVTTTL-compatible Inputs					
V_{IHT}	Input HIGH Voltage		2.0	$V_{CC} + 0.3$	V
V_{ILT}	Input LOW Voltage		-0.5	0.8	V
I_{IHT}	Input HIGH Current	REFCLKx Input, $V_{IN} = V_{CC}$		1.5	mA
		Other Inputs, $V_{IN} = V_{CC}$		+40	µA
I_{ILT}	Input LOW Current	REFCLKx Input, $V_{IN} = 0.0V$		-1.5	mA
		Other Inputs, $V_{IN} = 0.0V$		-40	µA
I_{IHPDT}	Input HIGH Current with internal pull-down	$V_{IN} = V_{CC}$		+200	µA
I_{ILPUT}	Input LOW Current with internal pull-up	$V_{IN} = 0.0V$		-200	µA
LVDIFF Inputs: REFCLKx±					
$V_{DIFF}^{[8]}$	Input Differential Voltage		400	V_{CC}	mV
V_{IHHP}	Highest Input HIGH Voltage		1.2	V_{CC}	V
V_{ILLP}	Lowest Input LOW voltage		0.0	$V_{CC}/2$	V
$V_{COMREF}^{[9]}$	Common Mode Range		1.0	$V_{CC} - 1.2V$	V
3-Level Inputs					
V_{IHH}	Three-Level Input HIGH Voltage	$\text{Min.} \leq V_{CC} \leq \text{Max.}$	$0.87 * V_{CC}$	V_{CC}	V
V_{IMM}	Three-Level Input MID Voltage	$\text{Min.} \leq V_{CC} \leq \text{Max.}$	$0.47 * V_{CC}$	$0.53 * V_{CC}$	V
V_{ILL}	Three-Level Input LOW Voltage	$\text{Min.} \leq V_{CC} \leq \text{Max.}$	0.0	$0.13 * V_{CC}$	V
I_{IHH}	Input HIGH Current	$V_{IN} = V_{CC}$		200	µA
I_{IMM}	Input MID current	$V_{IN} = V_{CC}/2$	-50	50	µA
I_{ILL}	Input LOW current	$V_{IN} = \text{GND}$		-200	µA
Differential CML Serial Outputs: OUTA1±, OUTA2±, OUTB1±, OUTB2±, OUTC1±, OUTC2±, OUTD1±, OUTD2±					
V_{OHC}	Output HIGH Voltage (V_{CC} Referenced)	100Ω differential load	$V_{CC} - 0.5$	$V_{CC} - 0.2$	V
		150Ω differential load	$V_{CC} - 0.5$	$V_{CC} - 0.2$	V
V_{OLC}	Output LOW Voltage (V_{CC} Referenced)	100Ω differential load	$V_{CC} - 1.4$	$V_{CC} - 0.7$	V
		150Ω differential load	$V_{CC} - 1.4$	$V_{CC} - 0.7$	V

Notes:

7. Tested one output at a time, output shorted for less than one second, less than 10% duty cycle.
8. This is the minimum difference in voltage between the true and complement inputs required to ensure detection of a logic-1 or logic-0. A logic-1 exists when the true (+) input is more positive than the complement (-) input. A logic-0 exists when the complement (-) input is more positive than true (+) input.
9. The common mode range defines the allowable range of REFCLKx+ and REFCLKx- when REFCLKx+ = REFCLKx-. This marks the zero-crossing between the true and complement inputs as the signal switches between a logic-1 and a logic-0.

CYV15G0403TB DC Electrical Characteristics (continued)

Parameter	Description	Test Conditions	Min.	Max.	Unit
V _{ODIF}	Output Differential Voltage (OUT+) - (OUT-)	100Ω differential load	450	900	mV
		150Ω differential load	560	1000	mV
Power Supply			Typ.	Max.	
I _{CC} ^[10,11]	Max Power Supply Current	REFCLKx = MAX Commercial	640	820	mA
I _{CC} ^[10,11]	Typical Power Supply Current	REFCLKx = 125 MHz Commercial	610	790	mA

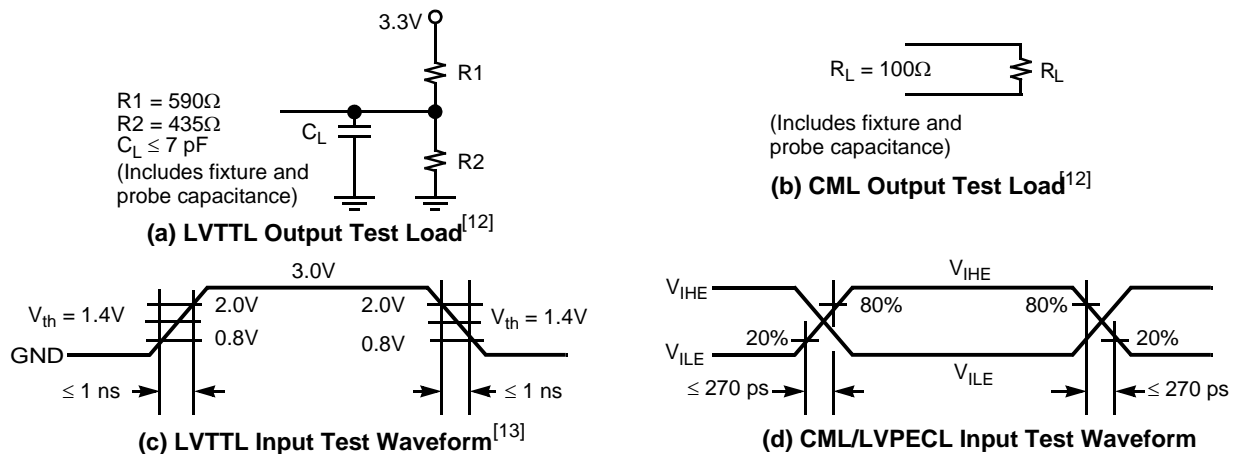
AC Test Loads and Waveforms

CYV15G0403TB AC Electrical Characteristics

Parameter	Description	Min.	Max.	Unit
CYV15G0403TB Transmitter LVTTTL Switching Characteristics Over the Operating Range				
f _{TS}	TXCLKx Clock Cycle Frequency	19.5	150	MHz
t _{TXCLK}	TXCLKx Period = 1/f _{TS}	6.66	51.28	ns
t _{TXCLKH} ^[14]	TXCLKx HIGH Time	2.2		ns
t _{TXCLKL} ^[14]	TXCLKx LOW Time	2.2		ns
t _{TXCLKR} ^[14, 15, 16, 17]	TXCLKx Rise Time	0.2	1.7	ns
t _{TXCLKF} ^[14, 15, 16, 17]	TXCLKx Fall Time	0.2	1.7	ns
t _{TXDS}	Transmit Data Set-up Time to TXCLKx↑ (TXCKSELx = 0)	2.2		ns
t _{TXDH}	Transmit Data Hold Time from TXCLKx↑ (TXCKSELx = 0)	1.0		ns
f _{TOS}	TXCLKOx Clock Frequency = 1x or 2x REFCLKx Frequency	19.5	150	MHz
t _{TXCLKO}	TXCLKOx Period = 1/f _{TOS}	6.66	51.28	ns
t _{TXCLKOD}	TXCLKO Duty Cycle centered at 60% HIGH time	-1.9	0	ns
CYV15G0403TB REFCLKx Switching Characteristics Over the Operating Range				
f _{REF}	REFCLKx Clock Frequency	19.5	150	MHz

Notes:

- Maximum I_{CC} is measured with V_{CC} = MAX, T_A = 25°C, with all channels and Serial Line Drivers enabled, sending a continuous alternating 01 pattern, and outputs unloaded.
- Typical I_{CC} is measured under similar conditions except with V_{CC} = 3.3V, T_A = 25°C, with all channels enabled and one Serial Line Driver per channel sending a continuous alternating 01 pattern. The redundant outputs on each channel are powered down.
- Cypress uses constant current (ATE) load configurations and forcing functions. This figure is for reference only.
- The LVTTTL switching threshold is 1.4V. All timing references are made relative to where the signal edges cross the threshold voltage.
- Tested initially and after any design or process changes that may affect these parameters, but not 100% tested.
- The ratio of rise time to falling time must not vary by greater than 2:1.
- For a given operating frequency, neither rise or fall specification can be greater than 20% of the clock-cycle period or the data sheet maximum time.
- All transmit AC timing parameters measured with 1 ns typical rise time and fall time.

CYV15G0403TB AC Electrical Characteristics (continued)

Parameter	Description	Min.	Max.	Unit
t _{REFCLK}	REFCLKx Period = 1/f _{REF}	6.6	51.28	ns
t _{REFH}	REFCLKx HIGH Time (TXRATEx = 1)(Half Rate)	5.9		ns
	REFCLKx HIGH Time (TXRATEx = 0)(Full Rate)	2.9 ^[14]		ns
t _{REFL}	REFCLKx LOW Time (TXRATEx = 1)(Half Rate)	5.9		ns
	REFCLKx LOW Time (TXRATEx = 0)(Full Rate)	2.9 ^[14]		ns
t _{REFD} ^[18]	REFCLKx Duty Cycle	30	70	%
t _{REFR} ^[14, 15, 16, 17]	REFCLKx Rise Time (20%–80%)		2	ns
t _{REFF} ^[14, 15, 16, 17]	REFCLKx Fall Time (20%–80%)		2	ns
t _{TREFDS}	Transmit Data Set-up Time to REFCLKx - Full Rate (TXRATEx = 0, TXCKSELx = 1)	2.4		ns
	Transmit Data Set-up Time to REFCLKx - Half Rate (TXRATEx = 1, TXCKSELx = 1)	2.3		ns
t _{TREFDH}	Transmit Data Hold Time from REFCLKx - Full Rate (TXRATEx = 0, TXCKSELx = 1)	1.0		ns
	Transmit Data Hold Time from REFCLKx - Half Rate (TXRATEx = 1, TXCKSELx = 1)	1.6		ns

CYV15G0403TB Bus Configuration Write Timing Characteristics Over the Operating Range

t _{DATAH}	Bus Configuration Data Hold	0		ns
t _{DATAS}	Bus Configuration Data Setup	10		ns
t _{WRENP}	Bus Configuration WREN Pulse Width	10		ns

CYV15G0403TB JTAG Test Clock Characteristics Over the Operating Range

f _{TCLK}	JTAG Test Clock Frequency		20	MHz
t _{TCLK}	JTAG Test Clock Period	50		ns

CYV15G0403TB Device RESET Characteristics Over the Operating Range

t _{RST}	Device RESET Pulse Width	30		ns
------------------	--------------------------	----	--	----

CYV15G0403TB Transmit Serial Outputs and TX PLL Characteristics Over the Operating Range

Parameter	Description	Condition	Min.	Max.	Unit
t _B	Bit Time		660	5128	ps
t _{RISE} ^[14]	CML Output Rise Time 20–80% (CML Test Load)	SPDSELx = HIGH	50	270	ps
		SPDSELx = MID	100	500	ps
		SPDSELx =LOW	180	1000	ps
t _{FALL} ^[14]	CML Output Fall Time 80–20% (CML Test Load)	SPDSELx = HIGH	50	270	ps
		SPDSELx = MID	100	500	ps
		SPDSELx =LOW	180	1000	ps

PLL Characteristics

Parameter	Description	Condition	Min.	Typ.	Max.	Unit
CYV15G0403TB Transmitter Output PLL Characteristics						
t _{JTGENSD} ^[14, 19]	Transmit Jitter Generation - SD Data Rate	REFCLKx = 27 MHz		200		ps
t _{JTGENHD} ^[14, 19]	Transmit Jitter Generation - HD Data Rate	REFCLKx = 148.5 MHz		76		ps
t _{TXLOCK}	Transmit PLL lock to REFCLKx±				200	µs

Notes:

18. The duty cycle specification is a simultaneous condition with the t_{REFH} and t_{REFL} parameters. This means that at faster character rates the REFCLKx± duty cycle cannot be as large as 30%–70%.
19. While sending BIST data at the corresponding data rate, after 10,000 histogram hits on a digital sampling oscilloscope, time referenced to REFCLKx± input.

Capacitance ^[14]

Parameter	Description	Test Conditions	Max.	Unit
C _{INTTL}	TTL Input Capacitance	T _A = 25°C, f ₀ = 1 MHz, V _{CC} = 3.3V	7	pF
C _{INPECL}	PECL input Capacitance	T _A = 25°C, f ₀ = 1 MHz, V _{CC} = 3.3V	4	pF

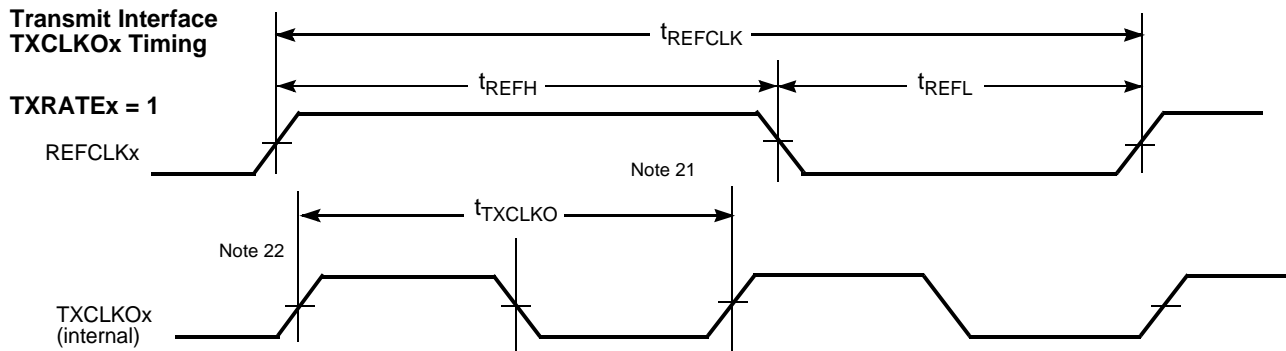
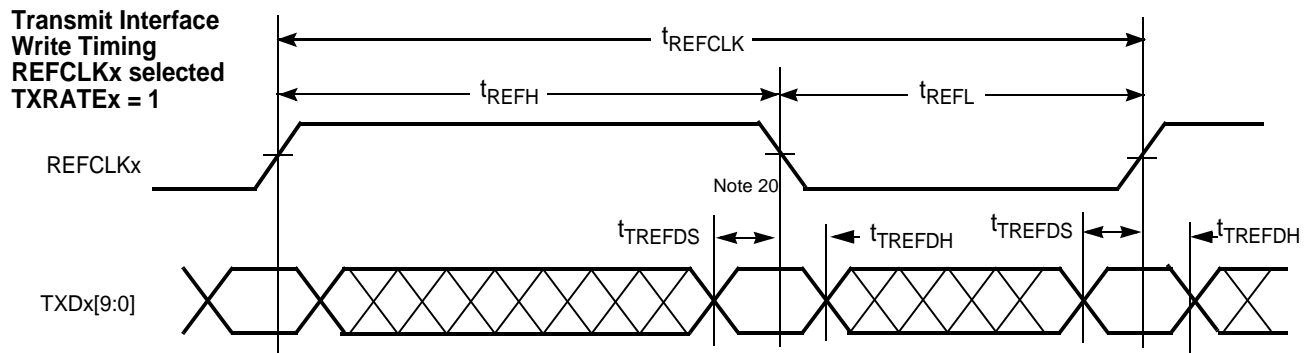
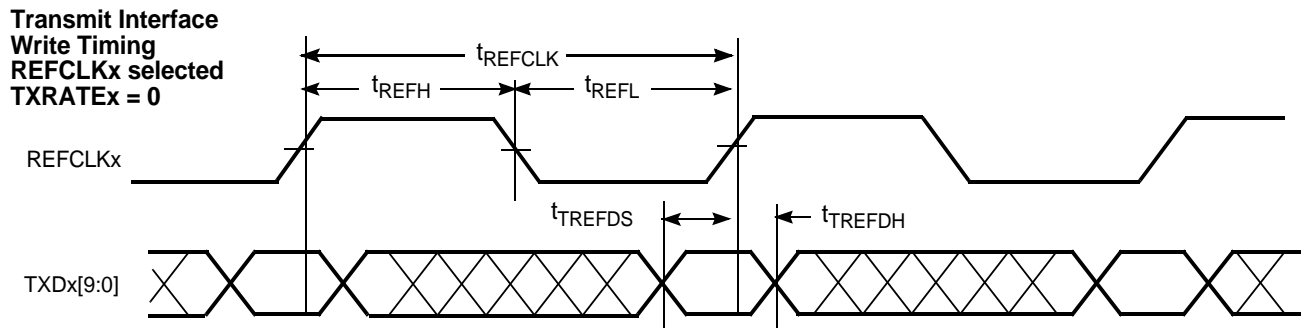
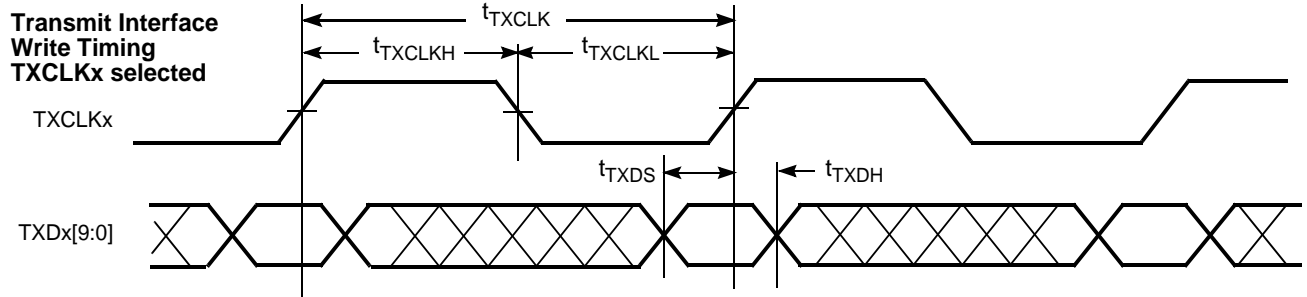
CYV15G0403TB HOTLink II Transmitter Switching Waveforms

Notes:

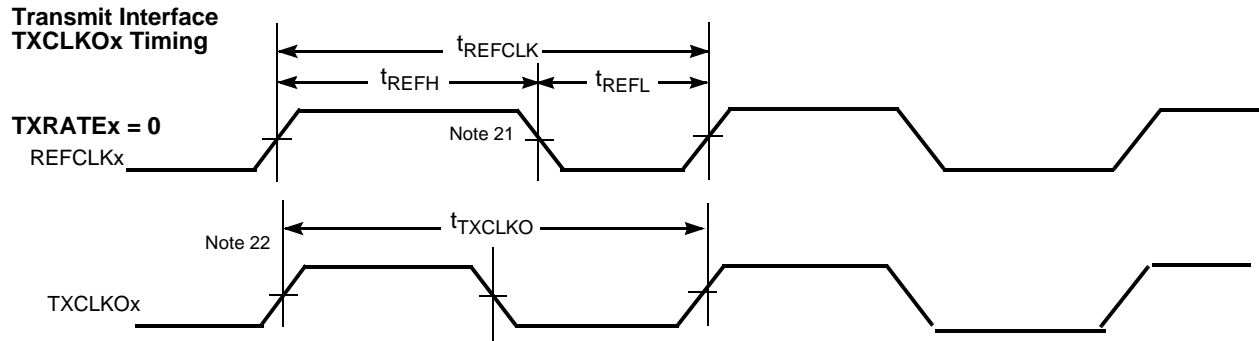
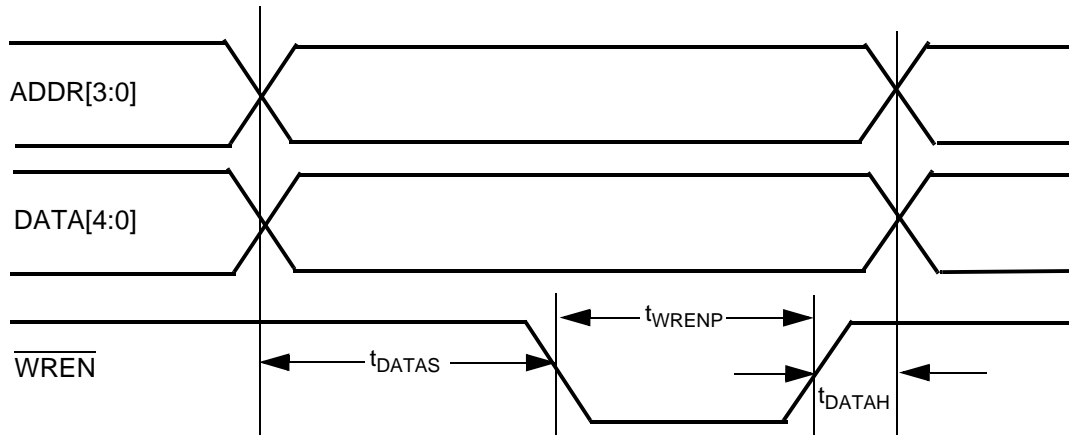
20. When REFCLKx± is configured for half-rate operation (TXRATEx = 1) and data is captured using REFCLKx instead of a TXCLKx clock. Data is captured using both the rising and falling edges of REFCLKx.
21. The TXCLKOx output remains at the character rate regardless of the state of TXRATEx and does not follow the duty cycle of REFCLKx±.

CYV15G0403TB HOTLink II Transmitter Switching Waveforms (continued)

CYV15G0403TB HOTLink II Bus Configuration Switching Waveforms
Bus Configuration Write Timing

Note:

22. The rising edge of TXCLKO_x output has no direct phase relationship to the REFCLK_{x±} input.

Table 4. Package Coordinate Signal Allocation

Ball ID	Signal Name	Signal Type	Ball ID	Signal Name	Signal Type	Ball ID	Signal Name	Signal Type
A01	NC	NO CONNECT	C07	NC	NO CONNECT	F17	NC	NO CONNECT
A02	OUTC1-	CML OUT	C08	GND	GROUND	F18	NC	NO CONNECT
A03	NC	NO CONNECT	C09	NC	NO CONNECT	F19	TXCLKOB	LVTTTL OUT
A04	OUTC2-	CML OUT	C10	NC	NO CONNECT	F20	NC	NO CONNECT
A05	VCC	POWER	C11	DATA[3]	LVTTTL IN PU	G01	TXDC[7]	LVTTTL IN
A06	NC	NO CONNECT	C12	DATA[1]	LVTTTL IN PU	G02	WREN	LVTTTL IN PU
A07	OUTD1-	CML OUT	C13	GND	GROUND	G03	TXDC[4]	LVTTTL IN
A08	GND	GROUND	C14	NC	NO CONNECT	G04	TXDC[1]	LVTTTL IN
A09	GND	GROUND	C15	SPDSELD	3-LEVEL SEL	G17	SPDSELB	3-LEVEL SEL
A10	OUTD2-	CML OUT	C16	VCC	POWER	G18	NC	NO CONNECT
A11	GND	GROUND	C17	NC	NO CONNECT	G19	SPDSELA	3-LEVEL SEL
A12	OUTA1-	CML OUT	C18	TRST	LVTTTL IN PU	G20	NC	NO CONNECT
A13	GND	GROUND	C19	GND	GROUND	H01	GND	GROUND
A14	GND	GROUND	C20	TDO	LVTTTL 3-S OUT	H02	GND	GROUND
A15	OUTA2-	CML OUT	D01	TCLK	LVTTTL IN PD	H03	GND	GROUND
A16	VCC	POWER	D02	RESET	LVTTTL IN PU	H04	GND	GROUND
A17	VCC	POWER	D03	VCC	POWER	H17	GND	GROUND
A18	OUTB1-	CML OUT	D04	VCC	POWER	H18	GND	GROUND
A19	VCC	POWER	D05	VCC	POWER	H19	GND	GROUND
A20	OUTB2-	CML OUT	D06	VCC	POWER	H20	GND	GROUND
B01	VCC	POWER	D07	SPDSELC	3-LEVEL SEL	J01	TXDC[9]	LVTTTL IN
B02	OUTC1+	CML OUT	D08	GND	GROUND	J02	TXDC[5]	LVTTTL IN
B03	VCC	POWER	D09	GND	GROUND	J03	TXDC[2]	LVTTTL IN
B04	OUTC2+	CML OUT	D10	DATA[4]	LVTTTL IN PU	J04	TXDC[3]	LVTTTL IN
B05	VCC	POWER	D11	DATA[2]	LVTTTL IN PU	J17	NC	NO CONNECT
B06	VCC	POWER	D12	DATA[0]	LVTTTL IN PU	J18	NC	NO CONNECT
B07	OUTD1+	CML OUT	D13	GND	GROUND	J19	NC	NO CONNECT
B08	GND	GROUND	D14	GND	GROUND	J20	NC	NO CONNECT
B09	NC	NO CONNECT	D15	NC	NO CONNECT	K01	NC	NO CONNECT
B10	OUTD2+	CML OUT	D16	VCC	POWER	K02	REFCLKC-	PECL IN
B11	NC	NO CONNECT	D17	NC	NO CONNECT	K03	TXDC[8]	LVTTTL IN
B12	OUTA1+	CML OUT	D18	NC	NO CONNECT	K04	TXCLKC	LVTTTL IN PD
B13	GND	GROUND	D19	SCANEN2	LVTTTL IN PD	K17	NC	NO CONNECT
B14	NC	NO CONNECT	D20	TMEN3	LVTTTL IN PD	K18	NC	NO CONNECT
B15	OUTA2+	CML OUT	E01	VCC	POWER	K19	NC	NO CONNECT
B16	VCC	POWER	E02	VCC	POWER	K20	NC	NO CONNECT
B17	NC	NO CONNECT	E03	VCC	POWER	L01	NC	NO CONNECT
B18	OUTB1+	CML OUT	E04	VCC	POWER	L02	REFCLKC+	PECL IN
B19	NC	NO CONNECT	E17	VCC	POWER	L03	NC	NO CONNECT
B20	OUTB2+	CML OUT	E18	VCC	POWER	L04	TXDC[6]	LVTTTL IN
C01	TDI	LVTTTL IN PU	E19	VCC	POWER	L17	NC	NO CONNECT
C02	TMS	LVTTTL IN PU	E20	VCC	POWER	L18	NC	NO CONNECT
C03	VCC	POWER	F01	NC	NO CONNECT	L19	NC	NO CONNECT

Table 4. Package Coordinate Signal Allocation (continued)

Ball ID	Signal Name	Signal Type	Ball ID	Signal Name	Signal Type	Ball ID	Signal Name	Signal Type
C04	VCC	POWER	F02	NC	NO CONNECT	L20	TXDB[6]	LVTTTL IN
C05	VCC	POWER	F03	TXDC[0]	LVTTTL IN	M01	NC	NO CONNECT
C06	NC	NO CONNECT	F04	NC	NO CONNECT	M02	NC	NO CONNECT
M03	NC	NO CONNECT	U03	TXDD[2]	LVTTTL IN	W03	NC	NO CONNECT
M04	TXERRC	LVTTTL OUT	U04	TXDD[9]	LVTTTL IN	W04	NC	NO CONNECT
M17	REFCLKB+	PECL IN	U05	VCC	POWER	W05	VCC	POWER
M18	REFCLKB-	PECL IN	U06	NC	NO CONNECT	W06	NC	NO CONNECT
M19	TXERRB	LVTTTL OUT	U07	NC	NO CONNECT	W07	NC	NO CONNECT
M20	TXCLKB	LVTTTL IN PD	U08	GND	GROUND	W08	GND	GROUND
N01	GND	GROUND	U09	TXDA[9]	LVTTTL IN	W09	ADDR [3]	LVTTTL IN PU
N02	GND	GROUND	U10	ADDR [0]	LVTTTL IN PU	W10	ADDR [1]	LVTTTL IN PU
N03	GND	GROUND	U11	REFCLKD-	PECL IN	W11	NC	NO CONNECT
N04	GND	GROUND	U12	TXDA[1]	LVTTTL IN	W12	TXERRA	LVTTTL OUT
N17	GND	GROUND	U13	GND	GROUND	W13	GND	GROUND
N18	GND	GROUND	U14	TXDA[4]	LVTTTL IN	W14	TXDA[2]	LVTTTL IN
N19	GND	GROUND	U15	TXDA[8]	LVTTTL IN	W15	TXDA[6]	LVTTTL IN
N20	GND	GROUND	U16	VCC	POWER	W16	VCC	POWER
P01	NC	NO CONNECT	U17	NC	NO CONNECT	W17	NC	NO CONNECT
P02	NC	NO CONNECT	U18	TXDB[8]	LVTTTL IN	W18	REFCLKA+	PECL IN
P03	NC	NO CONNECT	U19	NC	NO CONNECT	W19	NC	NO CONNECT
P04	NC	NO CONNECT	U20	NC	NO CONNECT	W20	NC	NO CONNECT
P17	TXDB[5]	LVTTTL IN	V01	TXDD[3]	LVTTTL IN	Y01	TXDD[6]	LVTTTL IN
P18	TXDB[4]	LVTTTL IN	V02	TXDD[4]	LVTTTL IN	Y02	TXCLKD	LVTTTL IN PD
P19	TXDB[3]	LVTTTL IN	V03	TXDD[8]	LVTTTL IN	Y03	NC	NO CONNECT
P20	TXDB[2]	LVTTTL IN	V04	NC	NO CONNECT	Y04	NC	NO CONNECT
R01	NC	NO CONNECT	V05	VCC	POWER	Y05	VCC	POWER
R02	TXCLKOC	LVTTTL OUT	V06	NC	NO CONNECT	Y06	NC	NO CONNECT
R03	NC	NO CONNECT	V07	NC	NO CONNECT	Y07	NC	NO CONNECT
R04	NC	NO CONNECT	V08	GND	GROUND	Y08	GND	GROUND
R17	TXDB[1]	LVTTTL IN	V09	NC	NO CONNECT	Y09	TXCLKOD	LVTTTL OUT
R18	TXDB[0]	LVTTTL IN	V10	ADDR [2]	LVTTTL IN PU	Y10	NC	NO CONNECT
R19	TXDB[9]	LVTTTL IN	V11	REFCLKD+	PECL IN	Y11	TXCLKA	LVTTTL IN PD
R20	TXDB[7]	LVTTTL IN	V12	TXCLKOA	LVTTTL OUT	Y12	NC	NO CONNECT
T01	VCC	POWER	V13	GND	GROUND	Y13	GND	GROUND
T02	VCC	POWER	V14	TXDA[3]	LVTTTL IN	Y14	TXDA[0]	LVTTTL IN
T03	VCC	POWER	V15	TXDA[7]	LVTTTL IN	Y15	TXDA[5]	LVTTTL IN
T04	VCC	POWER	V16	VCC	POWER	Y16	VCC	POWER
T17	VCC	POWER	V17	NC	NO CONNECT	Y17	TXERRD	LVTTTL OUT
T18	VCC	POWER	V18	NC	NO CONNECT	Y18	REFCLKA-	PECL IN
T19	VCC	POWER	V19	NC	NO CONNECT	Y19	NC	NO CONNECT
T20	VCC	POWER	V20	NC	NO CONNECT	Y20	NC	NO CONNECT
U01	TXDD[0]	LVTTTL IN	W01	TXDD[5]	LVTTTL IN			
U02	TXDD[1]	LVTTTL IN	W02	TXDD[7]	LVTTTL IN			

Ordering Information

Speed	Ordering Code	Package Name	Package Type	Operating Range
Standard	CYV15G0403TB-BGC	BL256	256-Ball Thermally Enhanced Ball Grid Array	Commercial
Standard	CYV15G0403TB-BGXC	BL256	Pb-Free 256-Ball Thermally Enhanced Ball Grid Array	Commercial

Package Diagram

256-Lead L2 Ball Grid Array (27 x 27 x 1.57 mm) BL256

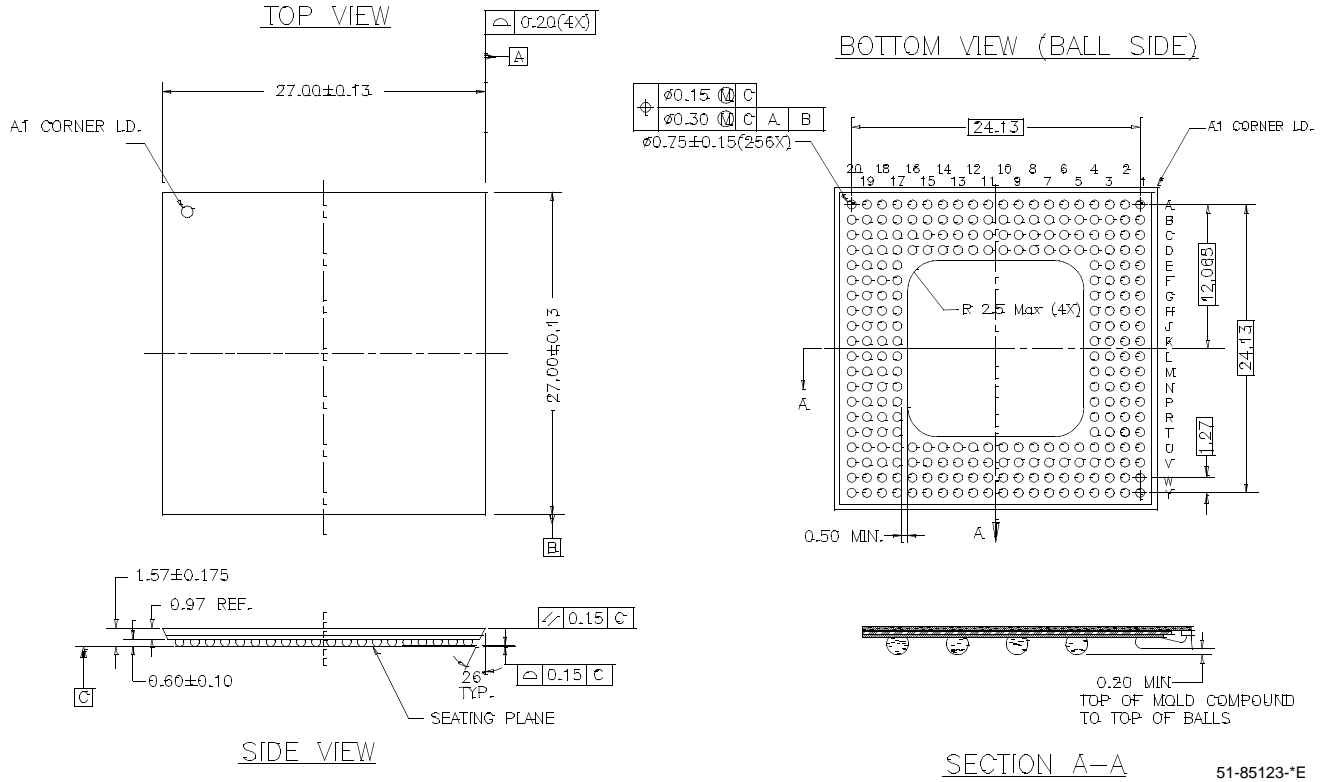

HOTLink is a registered trademark and HOTLink II is a trademark of Cypress Semiconductor. All product and company names mentioned in this document may be the trademarks of their respective holders.

Document History Page

Document Title: CYV15G0403TB Independent Clock Quad HOTLink II™ Serializer Document Number: 38-02104				
REV.	ECN NO.	ISSUE DATE	ORIG. OF CHANGE	DESCRIPTION OF CHANGE
**	246850	See ECN	FRE	New Data Sheet
*A	338721	See ECN	SUA	Added Pb-Free package option availability
*B	384307	See ECN	AGT	Revised setup and hold times (t_{TXDH} , t_{TREFDS} , t_{TREFDH})

Looking for pricing, stock, or lifecycle information?

Click below to explore more details on WIN SOURCE:

 [View CYV15G0403TB-BGXC on WIN SOURCE](#)

 [Cypress Semiconductor Corp](#) Information

Optimize Your Supply Chain with WIN SOURCE Solutions

-  Global Sourcing Solution
-  Obsolete Management
-  Cost Control Management
-  Shortage Management
-  Alternative Solution
-  Excess Inventory Management