



**THE DATASHEET OF
SG137T**



500mA Negative Adjustable Regulator

Description

The SG137A family of negative adjustable regulators deliver up to 500mA output current over an output voltage range of -1.2 V to -37 V. The device includes significant improvements, such as better line and load regulation, and a maximum output voltage error of 1%. The SG137 family uses the same chip design and guarantees maximum output voltage error of $\pm 2\%$.

Every effort is made to make these devices easy to use and difficult to damage. Internal current and power limiting coupled with true thermal limiting prevents device damage due to overloads or shorts even if the regulator is not fastened to a heat sink.

The SG137A/137 family of products are ideal complements to the SG117A/117 adjustable positive voltage regulators.

Features

- 1% Output Voltage Tolerance
- 0.01%/V Line Regulation
- 0.5% Load Regulation
- 0.02%/W Thermal Regulation

High Reliability Features - SG137A/SG137

- Available to MIL-STD-883
- MSC-AMS Level "S" Processing Available
- Available to DSCC
 - Standard Microcircuit Drawing (SMD)
- SGR137A/SGR137 Rad-Tolerant Version Available

Typical Application

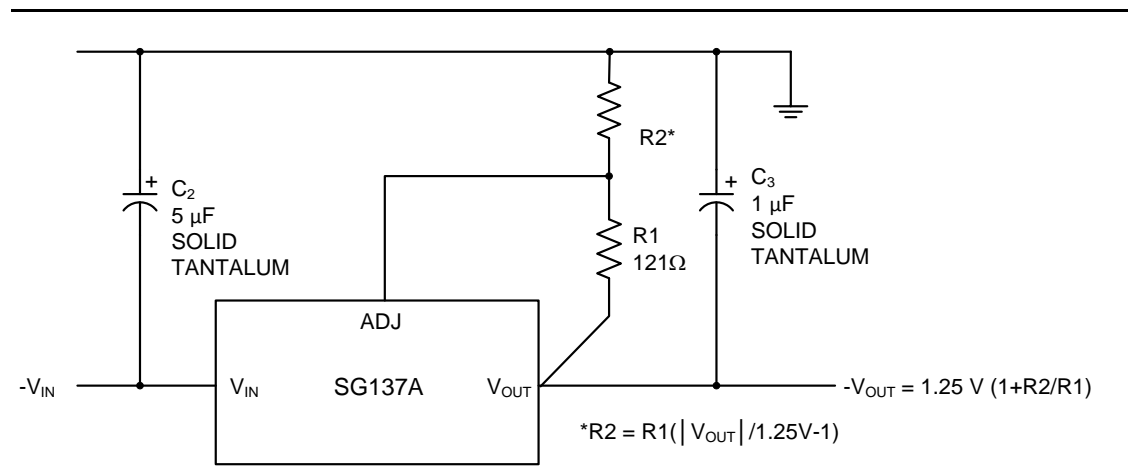

Figure 1 • Typical Application

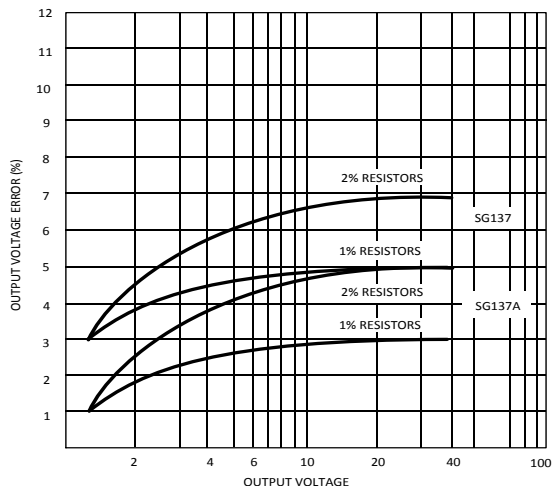

Figure 2 - Resistor Precision vs. Output Voltage Error

Connection Diagrams and Ordering Information

Ambient Temperature	Type	Package	Part Number	Packaging Type	Connection Diagram
-55°C to 125°C	T	3-Terminal Metal Can	SG137AT-883B	TO-39	
			SG137AT-DESC		
			SG137AT		
			SG137T-883B		
			SG137T-DESC		
			SG137T		
-55°C to 125°C	L	20-Pin CERAMIC Leadless Chip Carrier	SG137AL-883B	CLCC	<p>L PACKAGE (Top View) PbSn Lead Finish</p> <p>* Both V_{OUT} pins must be externally connected together at the device terminals.</p>
			SG137AL-DESC		
			SG137AL		
			SG137L-883B		
			SG137L-DESC		
			SG137L		

Absolute Maximum Ratings1

Parameter	Value	Units
Power Dissipation	Internally Limited	-
Input to Output Voltage Differential	40	V
Storage Temperature Range	-65 to 150	°C
Operating Junction Temperature	150	°C
Lead Temperature (Soldering, 10 Seconds)	300	°C
ESD Rating (Human Body Model)	2	kV

Notes:

1. Stresses above those listed in "ABSOLUTE MAXIMUM RATINGS", may cause permanent damage to the device. This is a stress only rating and operation of the device at these or any other conditions above those indicated in the operational sections of this specification is not implied. All voltages are with respect to Ground. Currents are positive into, negative out of specified terminal.

Thermal Data

Parameter	Value	Units
T Package:		
Thermal Resistance-Junction to Leads, θ_{JC}	15	°C/W
Thermal Resistance-Junction to Ambient, θ_{JA}	120	°C/W
L Package:		
Thermal Resistance-Junction to Leads, θ_{JC}	35	°C/W
Thermal Resistance-Junction to Ambient, θ_{JA}	120	°C/W

Notes:

- Junction Temperature Calculation: $T_J = T_A + (P_D \times \theta_{JA})$.
- The above numbers for θ_{JC} are maximums for limiting the thermal resistance of the package in a standard mounting configuration. The θ_{JA} numbers are the guidelines for the thermal performance of the device/pcboard system. All of the above assume no ambient airflow.

Recommended Operating Conditions^{2,3}

Symbol	Parameter	Recommended Operating Conditions			Units
		Min	Typ	Max	
V_{OUT}	Input Voltage Range	$-(V_{OUT} + 3.5V)$		-36	V
Operating Junction Temperature Range					
	SG137A/137	-55		150	°C

Note:

2. Range over which the device is functional.
3. These ratings are applicable for junction temperatures of less than 135°C.

Electrical Characteristics

Unless otherwise specified, these specifications apply over full operating ambient temperatures for SG137A/SG137 with $-55^{\circ}\text{C} \leq T_J \leq 150^{\circ}\text{C}$, $|V_{IN} - V_{OUT}| = 5.0\text{V}$, and for $I_{OUT} = 100\text{mA}$. Although power dissipation is internally limited, these specifications are applicable for power dissipations of 2W, and $I_{MAX} = 0.5\text{A}$. Low duty cycle pulse testing techniques are used which maintains junction and case temperatures equal to the ambient temperature.

Symbol	Test Conditions	SG137A			SG137			Units
		Min.	Typ.	Max	Min.	Typ.	Max	
Reference Voltage ⁶	$I_{OUT} = 10\text{mA}$, $T_J = 25^{\circ}\text{C}$	-1.238	-1.250	-1.262	-1.225	-1.250	-1.275	V
	$3\text{V} \leq V_{IN} - V_{OUT} \leq 40\text{V}$, $10\text{mA} \leq I_{OUT} \leq I_{MAX}$	-1.220	-1.250	-1.280	-1.200	-1.250	-1.300	V
Line Regulation ^{4,6}	$3\text{V} \leq V_{IN} - V_{OUT} \leq 40\text{V}$, $I_{OUT} \leq I_{MAX}$							
	$T_J = 25^{\circ}\text{C}$		0.005	0.01		0.01	0.02	%/V
Load Regulation ⁴	$10\text{mA} \leq I_{OUT} \leq I_{MAX}$							
	$ V_{OUT} \leq 5\text{V}$, $T_J = 25^{\circ}\text{C}$		5	25		15	25	mV
	$ V_{OUT} \geq 5\text{V}$, $T_J = 25^{\circ}\text{C}$		0.1	0.5		0.3	0.5	%
	$ V_{OUT} \leq 5\text{V}$		10	50		20	50	mV
	$ V_{OUT} \geq 5\text{V}$		0.2	1		0.3	1	%
Thermal Regulation ⁵	$T_J = 25^{\circ}\text{C}$, 10ms pulse		0.002	0.02		0.002	0.02	%/W
Ripple Rejection	$V_{OUT} = -10\text{V}$, $f = 120\text{Hz}$							
	$C_{ADJ} = 0$, $T_J = 25^{\circ}\text{C}$	60	66			60		dB
	$C_{ADJ} = 10\mu\text{F}$	70	80		66	77		dB
Adjust Pin Current	$T_A = 25^{\circ}\text{C}$		65	100		65	100	μA
Adjust Pin Current Change ⁶	$3\text{V} \leq V_{IN} - V_{OUT} \leq 40\text{V}$		1.0	5		2	5	μA
	$10\text{mA} \leq I_{OUT} \leq I_{MAX}$		0.2	2		0.5	5	μA
Minimum Load Current	$ V_{IN} - V_{OUT} \leq 40\text{V}$		2.5	5.0		2.5	5.0	mA
	$ V_{IN} - V_{OUT} \leq 10\text{V}$		1.2	3		1.2	3.0	mA
Current Limit	$ V_{IN} - V_{OUT} \leq 15\text{V}$	0.5	0.8	1.5	0.5	0.8		A
	$ V_{IN} - V_{OUT} \leq 40\text{V}$, $T_J = 25^{\circ}\text{C}$	0.15	0.25	0.5	0.15	0.25		A

Electrical Characteristics

Unless otherwise specified, these specifications apply over full operating ambient temperatures for SG137A/SG137 with $-55^{\circ}\text{C} \leq T_J \leq 150^{\circ}\text{C}$, $|V_{IN} - V_{OUT}| = 5.0\text{V}$, and for $I_{OUT} = 100\text{mA}$. Although power dissipation is internally limited, these specifications are applicable for power dissipations of 2W, and $I_{MAX} = 0.5\text{A}$. Low duty cycle pulse testing techniques are used which maintains junction and case temperatures equal to the ambient temperature.

Symbol	Test Conditions	SG137A			SG137			Units
		Min.	Typ.	Max	Min.	Typ.	Max	
Temperature Stability ⁵			0.6	1.5		0.6		%
Long Term Stability ⁵	$T_J = 125^{\circ}\text{C}$, 1000 Hours		0.3	1		0.3	1	%
RMS Output Noise (% of V_{OUT})	$T_J = 25^{\circ}\text{C}$, $10\text{Hz} \leq f \leq 10\text{kHz}$ ⁵		0.003			0.003		%

Notes:

4. Regulation is measured at constant junction temperature, using pulse testing with a low duty cycle. Changes in output voltage due to heating effects are covered under the specification for thermal regulation.
5. These parameters, although guaranteed, are not tested in production
6. I_{MAX} is $V_{IN} - V_{OUT} = 3\text{V} / 500\text{mA}$ and $V_{IN} - V_{OUT} = 40\text{V} / 150\text{mA}$.

Characteristic Curves

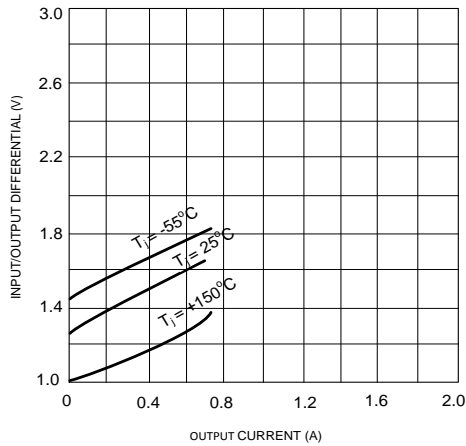

Figure 3 - Input/Output Differential vs. Output Current

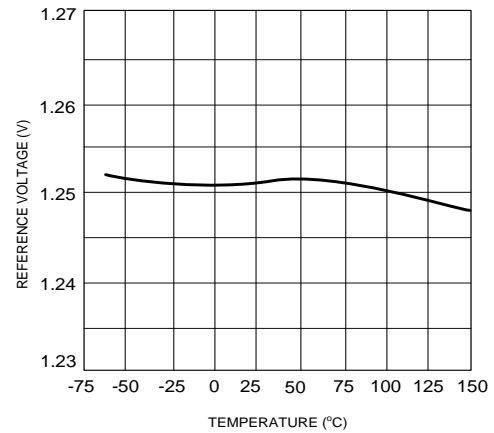

Figure 4 - Reference Voltage Vs. Temperature

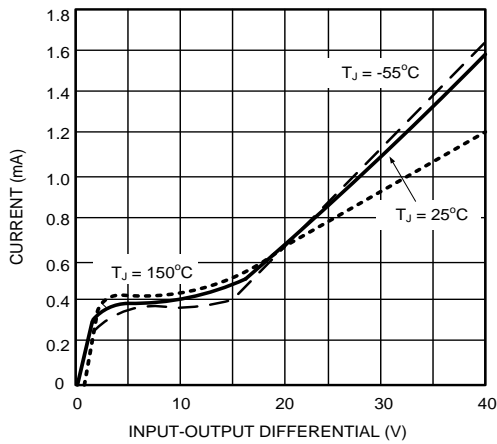

Figure 5 - Current Vs. Input/Output Differential

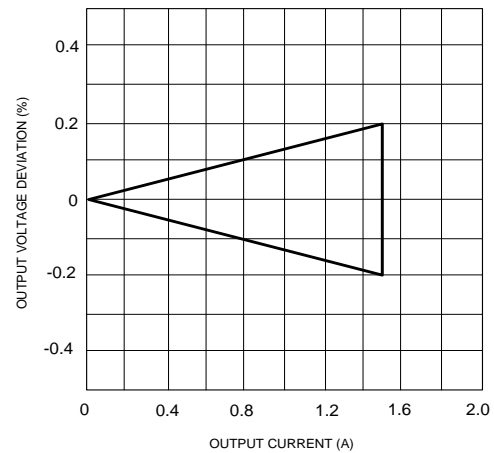

Figure 6 - Output Voltage Deviation Vs. Output Current*

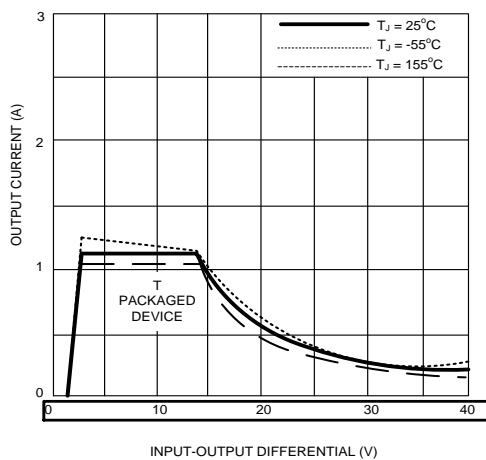

Figure 7 - Input/Output Differential Vs. Output Current

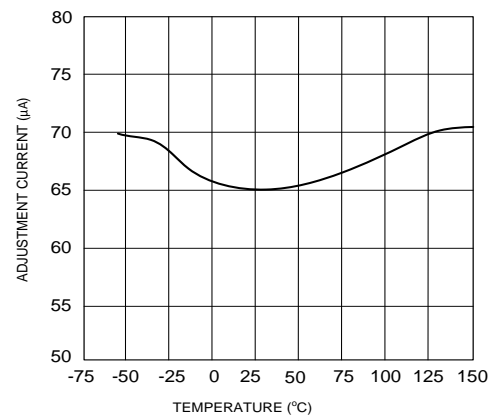

Figure 8 - Adjustment Current Vs. Temperature

*Notes: *The SG137A has load regulation compensation which makes the typical unit read close to zero. This band represents the typical production spread.*

Application Information

Output Voltage

The output voltage is determined by two external resistors, R_1 and R_2

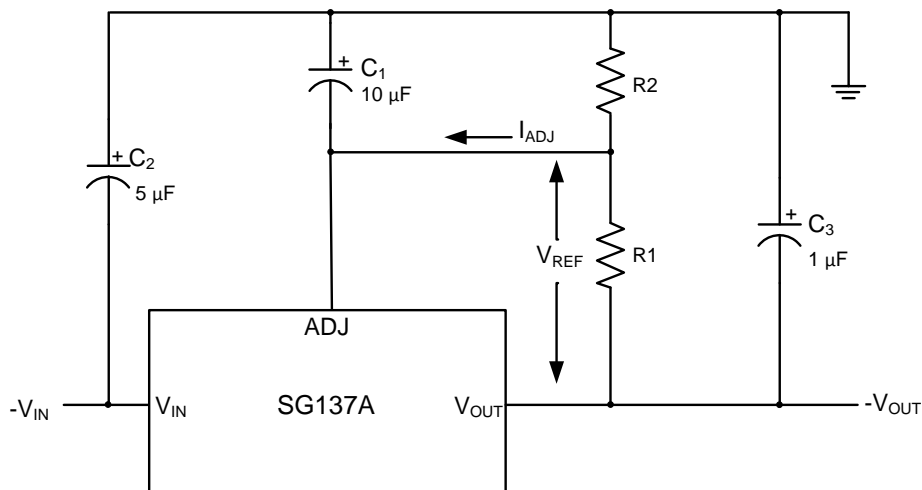

Figure 9 - Output Voltage

The exact formula for the output voltage is:

$$V_{OUT} = V_{REF} \left(\frac{R_2 + R_1}{R_1} \right) + I_{ADJ} (R_2)$$

Where: V_{REF} = Reference Voltage and I_{ADJ} = Adjustment Pin Current. In most applications, the second term is small enough to be ignored, typically about 0.5% of V_{OUT} . In more critical applications, the exact formula should be used, with I_{ADJ} equal to 65 μ A. Solving for R_2 yields:

$$R_2 = \frac{V_{OUT} - V_{REF}}{\frac{V_{REF}}{R_1} + I_{ADJ}}$$

Smaller values of R_1 and R_2 reduce the influence of I_{ADJ} on the output voltage, but the no-load current drain on the regulator is increased. Typical values for R_1 are between 100 Ω and 300 Ω , giving 12.5mA and 4.2mA no-load current. There is an additional consideration in selecting R_1 the minimum load current specification of the regulator. The operating current of the SG137A flows from input to output. If this current is not absorbed by the load, the output of the regulator rises above the regulated value. The current drawn by R_1 and R_2 is normally high enough to absorb the current, but care must be taken in no-load situations where R_1 and R_2 have high values. The maximum value for the operating current, which must be absorbed, is 5mA for the SG137A. If input and output voltage differential is less than 10V, the operating current that must be absorbed drops to 3mA.

Examples:

1. A precision 10V regulator to supply up to 1 Amp load current.
 - a. Select $R_1 = 100\Omega$ to minimize effect of I_{ADJ}
 - b. Calculate $R_2 = \frac{V_{OUT} - V_{REF}}{\left(\frac{V_{REF}}{R_1}\right) + I_{ADJ}} = \frac{10V - 1.25V}{\left(\frac{1.25V}{100\text{ ohms}}\right) + 65\mu A} = 704\text{ ohms}$

A 15 V regulator to run off batteries and supply 50mA. $V_{IN\ MAX} = 25V$

- c. To minimize battery drain, select R_1 as high as possible

$$R_1 = \frac{1.25V}{3mA} = 417\Omega, \text{ Use } 404\Omega, 1\%$$

Typical Application Circuits

The output stability, load regulation, line regulation, thermal regulation, temperature drift, long term drift, and noise can be improved by a factor of 6.6 over the standard regulator configuration. This assumes a zener whose drift and noise is considerably better than the regulator itself. The LM329B has 20PPM/°C maximum drift and about 10 times lower noise than the regulator.

In the application as shown figure 11, regulators #2 to #N tracks regulator #1 to within ± 24 mV initially, and to ± 60 mV over all load, line, and temperature conditions. If any regulator output is shorted to ground, all other outputs drop to -2V. Load regulation of regulators #2 to #N are improved by $V_{OUT}/1.25$ V compared to a standard regulator, so regulator #1 should be the one which has the lowest load current.

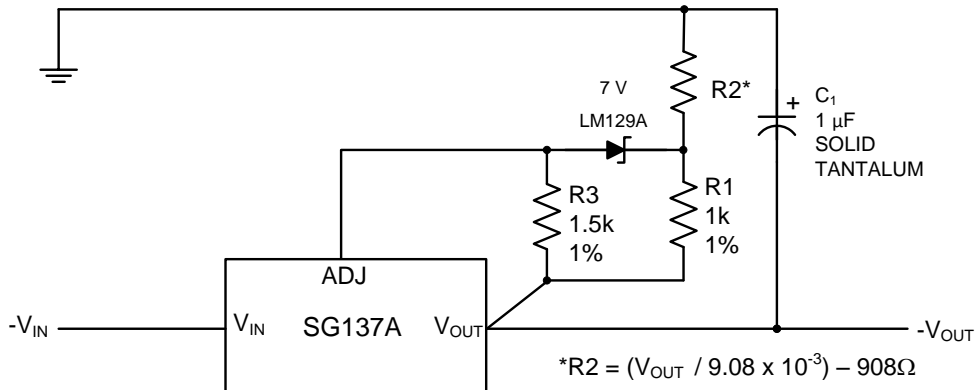

Figure 10 - High Stability Regulator

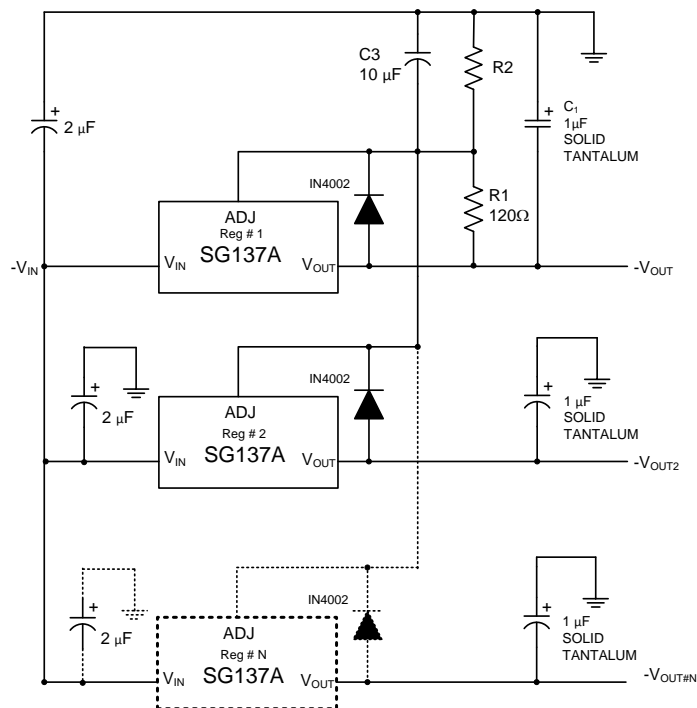

Figure 11 - Multiple Tracking Regulators

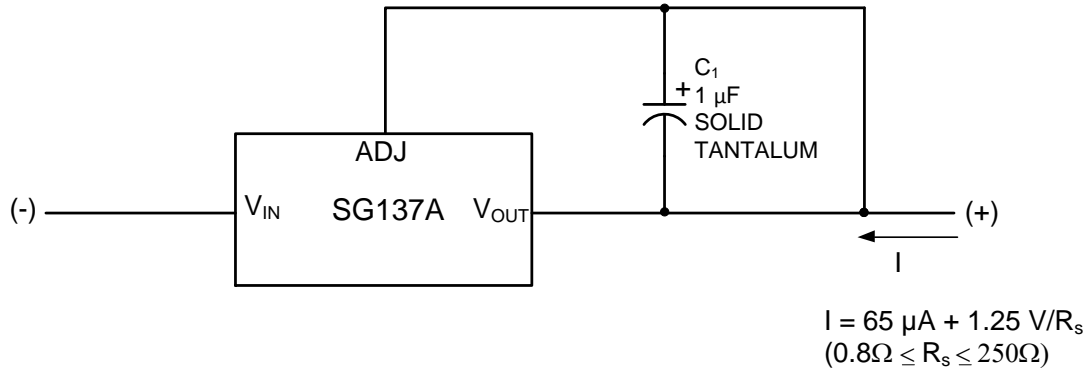

Figure 12 • Current Regulator

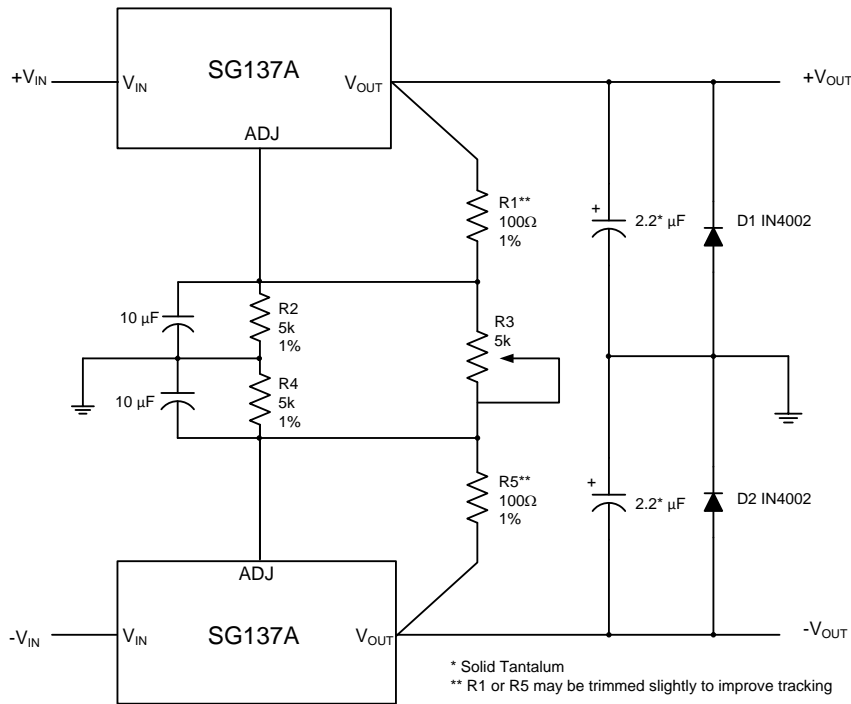
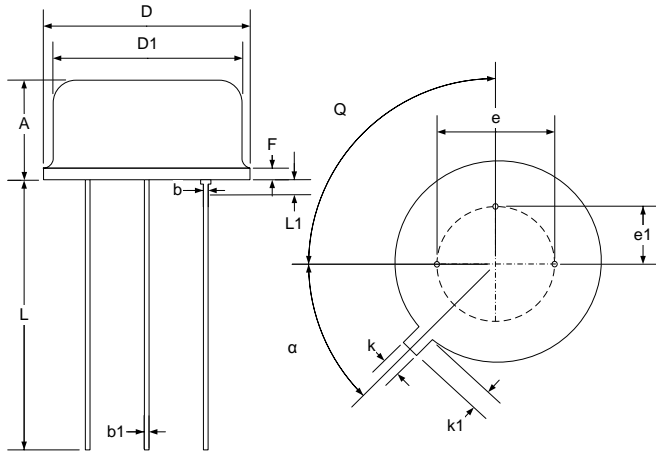

Figure 13 • Dual Tracking Supply $\pm 1.25 \text{ V}$ To $\pm 20 \text{ V}$

Package Outline Dimensions

Controlling dimensions are in inches, metric equivalents are shown for general information.



Dim	MILLIMETERS		INCHES	
	MIN	MAX	MIN	MAX
D	8.89	9.40	0.350	0.370
D1	8.13	8.51	0.320	0.335
A	4.19	4.70	0.165	0.185
b	0.41	0.48	0.016	0.019
F	-	1.02	-	0.040
e	5.08 BSC		0.200 BSC	
k	0.71	0.86	0.028	0.034
k1	0.74	1.14	0.029	0.045
L	12.70	14.48	0.500	0.570
α	45° TYP		45° TYP	
e1	2.54 TYP		0.100 TYP	
b1	0.41	0.53	0.016	0.021
Q	90° TYP		90° TYP	
L1	-	1.27	-	0.50

Figure 14 • T 3-Pin Metal Can TO-39 Package Dimensions

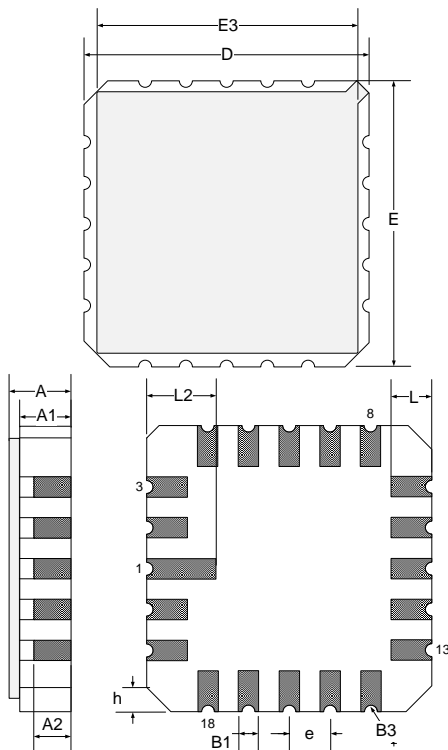

Dim	MILLIMETERS		INCHES	
	MIN	MAX	MIN	MAX
D/E	8.64	9.14	0.340	0.360
E3	-	8.128	-	0.320
e	1.270 BSC		0.050 BSC	
B1	0.635 TYP		0.025 TYP	
L	1.02	1.52	0.040	0.060
A	1.626	2.286	0.064	0.090
h	1.016 TYP		0.040 TYP	
A1	1.372	1.68	0.054	0.066
A2	-	1.168	-	0.046
L2	1.91	2.41	0.075	0.95
B3	0.203R		0.008R	

Note:

- All exposed metalized area shall be gold plated 60 micro-inch minimum thickness over nickel plated unless otherwise specified in purchase order.

Figure 15 • L 20-Pin Ceramic Leadless Chip Carrier (LCC) Package Dimensions



Microsemi Corporate Headquarters
One Enterprise, Aliso Viejo,
CA 92656 USA

Within the USA: +1 (800) 713-4113
Outside the USA: +1 (949) 380-6100
Sales: +1 (949) 380-6136
Fax: +1 (949) 215-4996

E-mail: sales.support@microsemi.com



© 2014 Microsemi Corporation. All rights reserved. Microsemi and the Microsemi logo are trademarks of Microsemi Corporation. All other trademarks and service marks are the property of their respective owners.

Microsemi Corporation (Nasdaq: MSCC) offers a comprehensive portfolio of semiconductor and system solutions for communications, defense & security, aerospace and industrial markets. Products include high-performance and radiation-hardened analog mixed-signal integrated circuits, FPGAs, SoCs and ASICs; power management products; timing and synchronization devices and precise time solutions, setting the world's standard for time; voice processing devices; RF solutions; discrete components; security technologies and scalable anti-tamper products; Power-over-Ethernet ICs and midspans; as well as custom design capabilities and services. Microsemi is headquartered in Aliso Viejo, Calif., and has approximately 3,400 employees globally. Learn more at www.microsemi.com.

Microsemi makes no warranty, representation, or guarantee regarding the information contained herein or the suitability of its products and services for any particular purpose, nor does Microsemi assume any liability whatsoever arising out of the application or use of any product or circuit. The products sold hereunder and any other products sold by Microsemi have been subject to limited testing and should not be used in conjunction with mission-critical equipment or applications. Any performance specifications are believed to be reliable but are not verified, and Buyer must conduct and complete all performance and other testing of the products, alone and together with, or installed in, any end-products. Buyer shall not rely on any data and performance specifications or parameters provided by Microsemi. It is the Buyer's responsibility to independently determine suitability of any products and to test and verify the same. The information provided by Microsemi hereunder is provided "as is, where is" and with all faults, and the entire risk associated with such information is entirely with the Buyer. Microsemi does not grant, explicitly or implicitly, to any party any patent rights, licenses, or any other IP rights, whether with regard to such information itself or anything described by such information. Information provided in this document is proprietary to Microsemi, and Microsemi reserves the right to make any changes to the information in this

Looking for pricing, stock, or lifecycle information?

Click below to explore more details on WIN SOURCE:

-  [View SG137T on WIN SOURCE](#)
-  [Microsemi Corporation](#) Information

Optimize Your Supply Chain with WIN SOURCE Solutions

-  Global Sourcing Solution
-  Obsolete Management
-  Cost Control Management
-  Shortage Management
-  Alternative Solution
-  Excess Inventory Management