



# RPM-Based Fan Controller with Hardware Thermal Shutdown

## PRODUCT FEATURES

Data Brief

### General Description

The EMC2103 is an SMBus compliant fan controller with up to up to 3 external and 1 internal temperature channels. The fan driver can be operated using two methods each with two modes. The methods include an RPM based Fan Speed Control Algorithm and a direct PWM drive setting. The modes include manually programming the desired settings or using the internal programmable temperature look-up table to select the desired setting based on measured temperature.

The temperature monitors offer 1°C accuracy (for external diodes) with sophisticated features to reduce errors introduced by series resistance and beta variation of substrate thermal diode transistors commonly found in processors.

The EMC2103 also includes a hardware programmable temperature limit and dedicated system shutdown output for thermal protection of critical circuitry.

### Applications

- Notebook Computers
- Projectors
- Graphics Cards
- Industrial and Networking Equipment

### Features

- Programmable Fan Control circuit
  - 4-wire fan compatible
  - High and low frequency PWM
- RPM based fan control algorithm
  - 2.5% accuracy from 500RPM to 16k RPM
  - Detects fan aging and variation
- Temperature Look-Up Table
  - Allows programmed fan response to temperature
  - Controls fan speed or PWM drive setting
  - Allows externally set temperature data to drive fan
  - Supports DTS data from CPU
- Up to Three External Temperature Channels (EMC2103-2 only)
  - Supports 45nm, 60nm, and 90nm CPU diodes
  - Automatically detects and supports CPUs requiring BJT or Transistor models
  - Resistance error correction
  - Supports discrete transistors (i.e. 2N3904)
  - 1°C accurate (60°C to 125°C)
  - 0.125°C resolution
- Hardware Programmable Thermal Shutdown Temperature
  - Cannot be altered by software
  - 65°C to 127°C Range
- Programmable High and Low Limits for all channels
- Internal Temperature Monitor
  - 2°C accuracy
  - 0.125°C resolution
- 3.3V Supply Voltage
- SMBus 2.0 Compliant
  - SMBus Alert compatible
- Two dedicated GPIOs (EMC2103-2 and EMC2103-4 only)
- Available in 12-pin, QFN Lead-Free RoHS Compliant Package (EMC2103-1 and EMC2103-3) or 16-pin, QFN Lead-Free RoHS Compliant Package (EMC2103-2 and EMC2103-4)

**ORDER NUMBERS:**

ORDERING NUMBER	PACKAGE	FEATURES
EMC2103-1-KP-TR	12-pin, QFN Lead-Free, ROHS Compliant	One external diode, RPM based Fan Speed Control Algorithm, High Frequency PWM driver, HW Thermal / Critical shutdown, EEPROM Load disabled
EMC2103-2-AP-TR	16-pin, QFN Lead-Free, ROHS Compliant	Up to three external diodes, RPM based Fan Speed Control algorithm, High Frequency PWM driver, HW Thermal / Critical shutdown, 2 GPIOs, EEPROM Load disabled
EMC2103-4-AP-TR	16-pin, QFN Lead-Free, ROHS Compliant	Up to three external diodes, RPM based Fan Speed Control algorithm, High Frequency PWM driver, HW Thermal / Critical shutdown, 2 GPIOs, EEPROM Load enabled

**REEL SIZE IS 4,000 PIECES**

**This product meets the halogen maximum concentration values per IEC61249-2-21  
For RoHS compliance and environmental information, please visit [www.smSC.com/rohs](http://www.smSC.com/rohs)**



80 ARKAY DRIVE, HAUPPAUGE, NY 11788 (631) 435-6000, FAX (631) 273-3123

Copyright © 2010 SMSC or its subsidiaries. All rights reserved.

Circuit diagrams and other information relating to SMSC products are included as a means of illustrating typical applications. Consequently, complete information sufficient for construction purposes is not necessarily given. Although the information has been checked and is believed to be accurate, no responsibility is assumed for inaccuracies. SMSC reserves the right to make changes to specifications and product descriptions at any time without notice. Contact your local SMSC sales office to obtain the latest specifications before placing your product order. The provision of this information does not convey to the purchaser of the described semiconductor devices any licenses under any patent rights or other intellectual property rights of SMSC or others. All sales are expressly conditional on your agreement to the terms and conditions of the most recently dated version of SMSC's standard Terms of Sale Agreement dated before the date of your order (the "Terms of Sale Agreement"). The product may contain design defects or errors known as anomalies which may cause the product's functions to deviate from published specifications. Anomaly sheets are available upon request. SMSC products are not designed, intended, authorized or warranted for use in any life support or other application where product failure could cause or contribute to personal injury or severe property damage. Any and all such uses without prior written approval of an Officer of SMSC and further testing and/or modification will be fully at the risk of the customer. Copies of this document or other SMSC literature, as well as the Terms of Sale Agreement, may be obtained by visiting SMSC's website at <http://www.smSC.com>. SMSC is a registered trademark of Standard Microsystems Corporation ("SMSC"). Product names and company names are the trademarks of their respective holders.

**SMSC DISCLAIMS AND EXCLUDES ANY AND ALL WARRANTIES, INCLUDING WITHOUT LIMITATION ANY AND ALL IMPLIED WARRANTIES OF MERCHANTABILITY, FITNESS FOR A PARTICULAR PURPOSE, TITLE, AND AGAINST INFRINGEMENT AND THE LIKE, AND ANY AND ALL WARRANTIES ARISING FROM ANY COURSE OF DEALING OR USAGE OF TRADE. IN NO EVENT SHALL SMSC BE LIABLE FOR ANY DIRECT, INCIDENTAL, INDIRECT, SPECIAL, PUNITIVE, OR CONSEQUENTIAL DAMAGES; OR FOR LOST DATA, PROFITS, SAVINGS OR REVENUES OF ANY KIND; REGARDLESS OF THE FORM OF ACTION, WHETHER BASED ON CONTRACT; TORT; NEGLIGENCE OF SMSC OR OTHERS; STRICT LIABILITY; BREACH OF WARRANTY; OR OTHERWISE; WHETHER OR NOT ANY REMEDY OF BUYER IS HELD TO HAVE FAILED OF ITS ESSENTIAL PURPOSE, AND WHETHER OR NOT SMSC HAS BEEN ADVISED OF THE POSSIBILITY OF SUCH DAMAGES.**

# Block Diagram

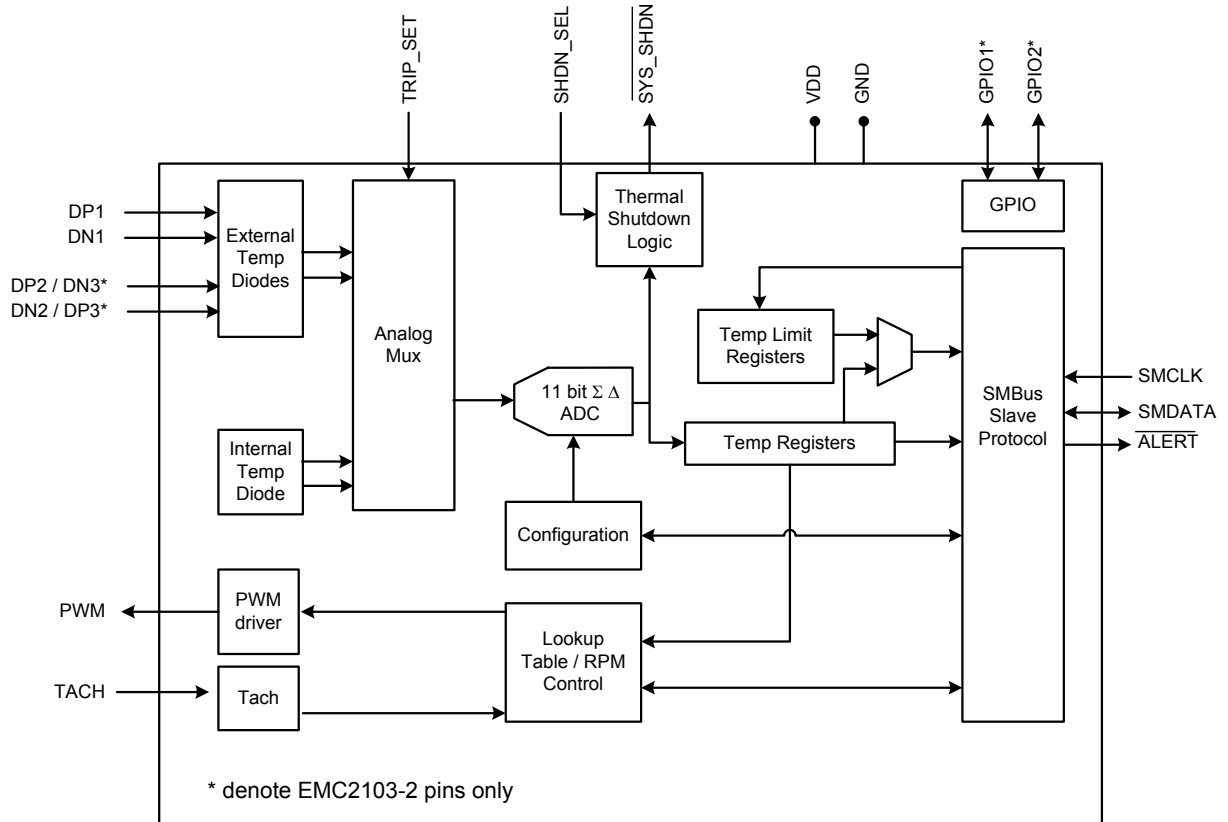

Figure 1 EMC2103 Block Diagram

## Package Outline

### EMC2103-1 Package Information

COMMON DIMENSIONS					
SYMBOL	MIN	NOM	MAX	NOTE	REMARK
A	0.80	0.85	0.90	-	OVERALL PACKAGE HEIGHT
A1	0	0.02	0.05	-	STANDOFF
A3	0.20 REF			-	LEAD-FRAME THICKNESS
D/E	3.90	4.00	4.10	-	X/Y BODY SIZE
D2/E2	2.00	2.10	2.20	2	X/Y EXPOSED PAD SIZE
L	0.45	0.50	0.55	-	TERMINAL LENGTH
b	0.25	0.30	0.35	2	TERMINAL WIDTH
K	0.20	-	-	-	TERMINAL TO PAD DISTANCE
e	0.80 BSC			-	TERMINAL PITCH

#### NOTES:

1. ALL DIMENSIONS ARE IN MILLIMETERS.
2. POSITION TOLERANCE OF EACH TERMINAL AND EXPOSED PAD IS  $\pm 0.05\text{mm}$  AT MAXIMUM MATERIAL CONDITION. DIMENSIONS "b" APPLIES TO PLATED TERMINALS AND IT IS MEASURED BETWEEN 0.15 AND 0.30 mm FROM THE TERMINAL TIP.
3. DETAILS OF TERMINAL #1 IDENTIFIER ARE OPTIONAL BUT MUST BE LOCATED WITHIN THE AREA INDICATED.

Figure 2 Preliminary 12-Pin QFN 4mm x 4mm Package Dimensions

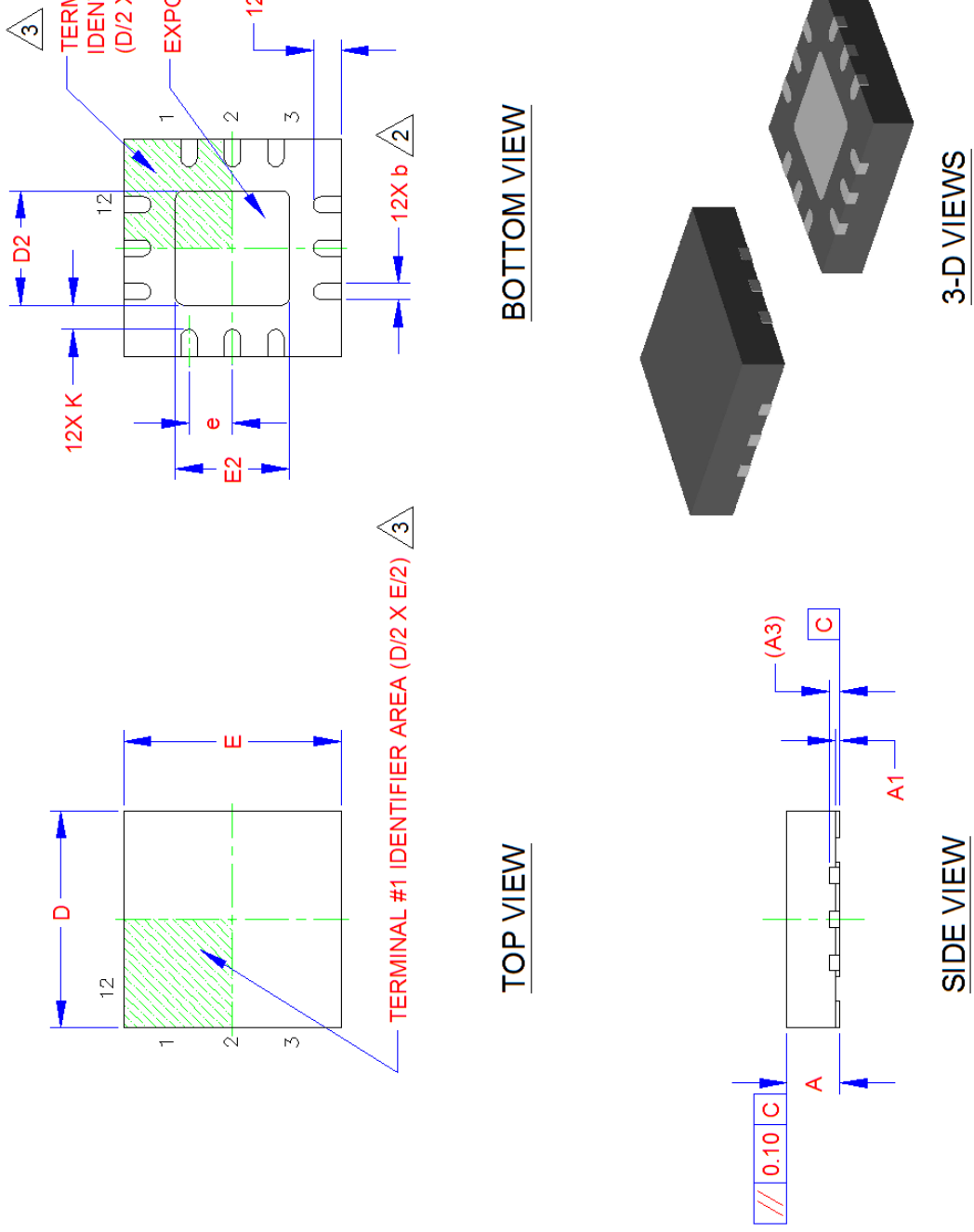
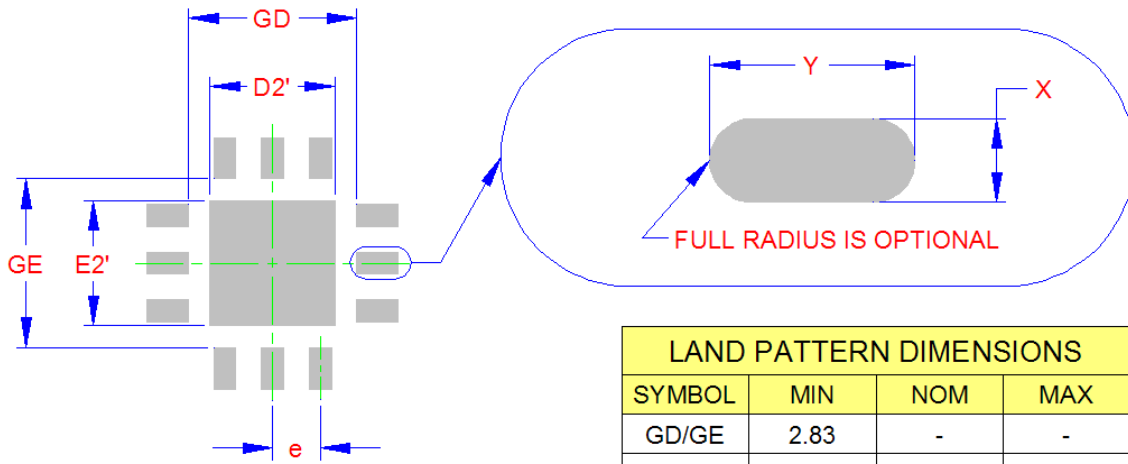

Figure 3 Preliminary 12-Pin QFN 4mm x 4mm Package Drawing



THE USER MAY MODIFY THE PCB  
LAND PATTERN DIMENSIONS  
BASED ON THEIR EXPERIENCE  
AND/OR PROCESS CAPABILITY

LAND PATTERN DIMENSIONS			
SYMBOL	MIN	NOM	MAX
GD/GE	2.83	-	-
D2'/E2'	-	2.10	-
X	-	-	0.37
Y	-	-	0.69
e	0.80		

### RECOMMENDED PCB LAND PATTERN

Figure 4 Recommended PCB Footprint 12-Pin QFN 4mm x 4mm

## EMC2103-2 Package Information

COMMON DIMENSIONS					
SYMBOL	MIN	NOM	MAX	NOTE	REMARK
A	0.80	0.85	0.90	-	OVERALL PACKAGE HEIGHT
A1	0	0.02	0.05	-	STANDOFF
A3	0.20 REF			-	LEAD-FRAME THICKNESS
D/E	3.90	4.00	4.10	-	X/Y BODY SIZE
D2/E2	2.00	2.10	2.20	2	X/Y EXPOSED PAD SIZE
L	0.45	0.50	0.55	-	TERMINAL LENGTH
b	0.25	0.30	0.35	2	TERMINAL WIDTH
K	0.20	-	-	-	TERMINAL TO PAD DISTANCE
e	0.65 BSC			-	TERMINAL PITCH

### NOTES:

1. ALL DIMENSIONS ARE IN MILLIMETERS.
2. POSITION TOLERANCE OF EACH TERMINAL AND EXPOSED PAD IS  $\pm 0.05$ mm AT MAXIMUM MATERIAL CONDITION. DIMENSIONS "b" APPLIES TO PLATED TERMINALS AND IT IS MEASURED BETWEEN 0.15 AND 0.30 mm FROM THE TERMINAL TIP.
3. DETAILS OF TERMINAL #1 IDENTIFIER ARE OPTIONAL BUT MUST BE LOCATED WITHIN THE AREA INDICATED.

Figure 5 Preliminary 16-Pin QFN 4mm x 4mm Package Dimensions

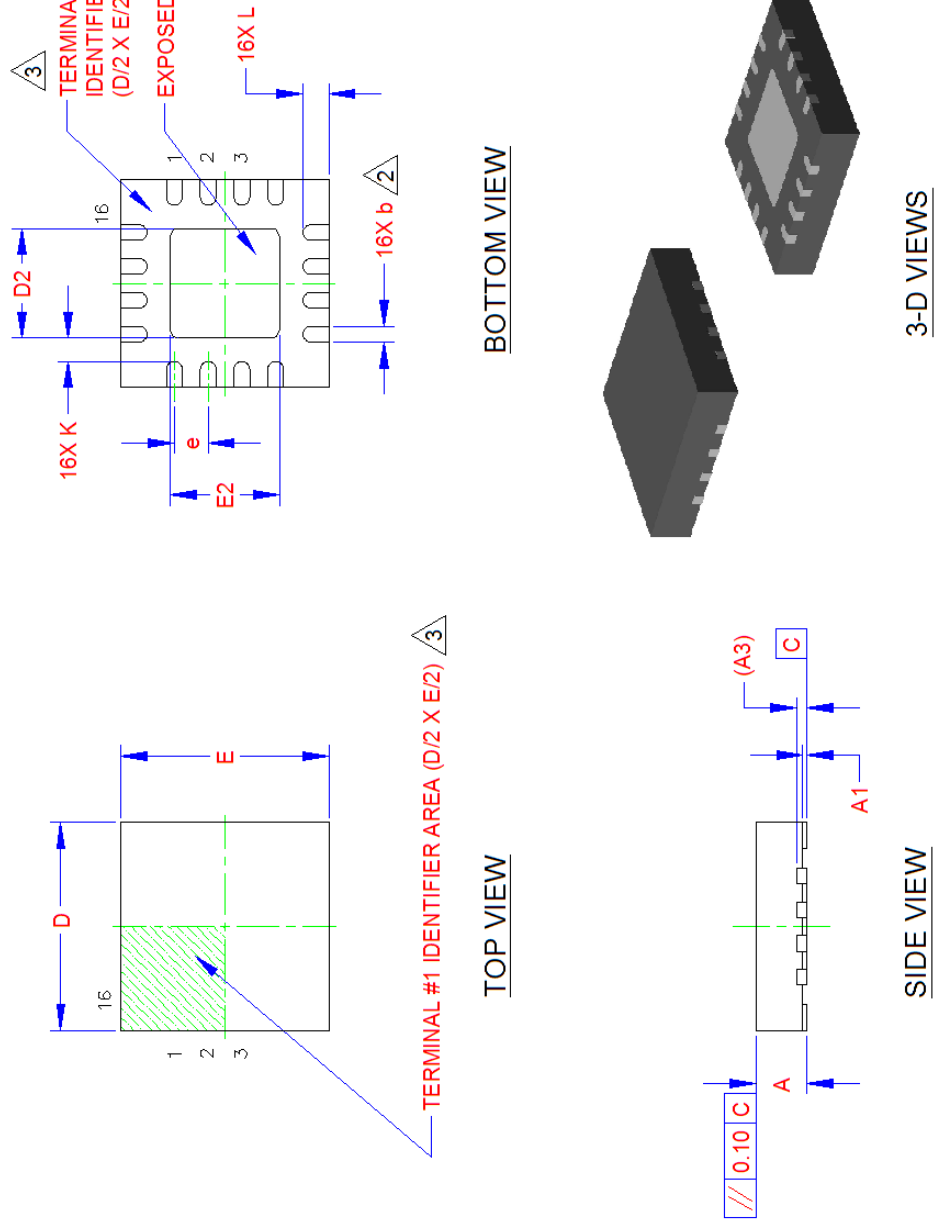
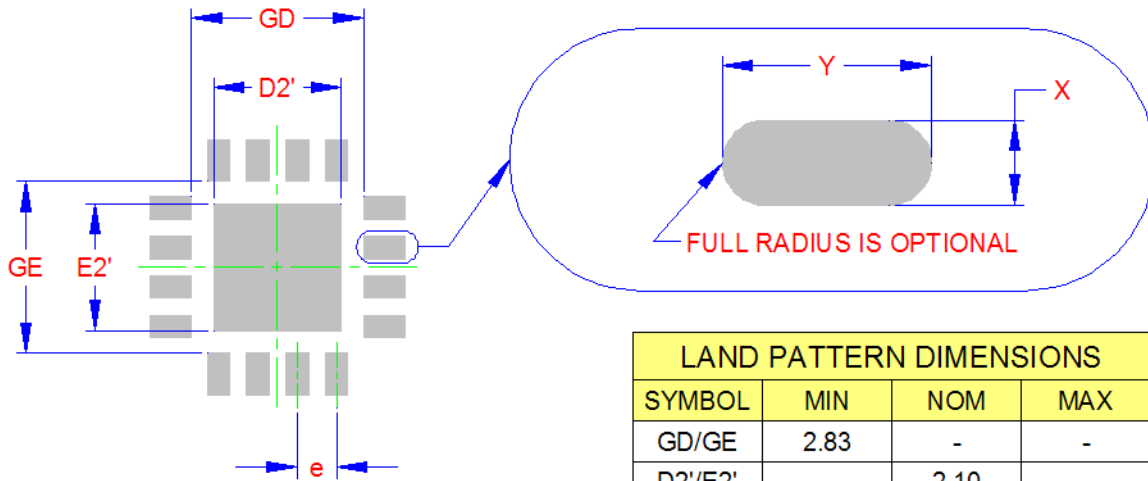

Figure 6 Preliminary 16-Pin QFN 4mm x 4mm Package Drawing



THE USER MAY MODIFY THE PCB  
LAND PATTERN DIMENSIONS  
BASED ON THEIR EXPERIENCE  
AND/OR PROCESS CAPABILITY

LAND PATTERN DIMENSIONS			
SYMBOL	MIN	NOM	MAX
GD/GE	2.83	-	-
D2'/E2'	-	2.10	-
X	-	-	0.37
Y	-	-	0.69
e	0.65		

### RECOMMENDED PCB LAND PATTERN

Figure 7 Recommended PCB Footprint 16-Pin QFN 4mm x 4mm

## Looking for pricing, stock, or lifecycle information?

Click below to explore more details on WIN SOURCE:

- ⊖ [View EMC2103-1-KP-TR on WIN SOURCE](#)
- ⊖ [Microchip Technology](#) Information

## Optimize Your Supply Chain with WIN SOURCE Solutions

- ✓ Global Sourcing Solution
- ✓ Obsolete Management
- ✓ Cost Control Management
- ✓ Shortage Management
- ✓ Alternative Solution
- ✓ Excess Inventory Management