



**THE DATASHEET OF  
LCP02-150B1**





# LCP02-150B1

A.S.D.™

## PROTECTION IC FOR RINGING SLICs

### FEATURES

- Protection IC recommended for ringing SLICs.
- Wide firing voltage range: from -110V to +95V.
- Low gate triggering current:  $I_G = 5\text{mA max.}$
- Peak pulse current:  $I_{PP} = 30\text{A (10/1000}\mu\text{s)}$ .
- Holding current:  $I_H = 150\text{mA min.}$
- UL497B approved (file E136224)

### MAIN APPLICATIONS

- Dual battery supply voltage SLICs
  - negative battery supply configuration
  - negative & positive battery supply configuration
- Central Office (CO)
- Private Branch Exchange (PBX)
- Digital Loop Carrier (DLC)
- Asymmetrical Digital Subscriber Line (ADSL G.Lite)
- Fiber in the Loop (FITL)
- Wireless Local Loop (WLL)
- Hybrid Fiber Coax (HFC)
- ISDN Terminal Adapter
- Cable modem

### DESCRIPTION

The LCP02-150B1 has been developed to protect SLICs operating on both negative and positive battery supplies, as well as on high voltage SLICs. It provides crowbar mode protection for both TIP and RING lines. The surge suppression is assumed for each wire by two thyristor structures, one dedicated to positive surges the second one for negative surges. Both positive and negative threshold levels are programmable by two gates (Gn and Gp). The use of transistors decreases the battery currents during surge suppression.

The LCP02-150B1 has high Bellcore Core, ITU-T and FCC Part 68 lightning surge ratings, ensuring rugged performance in the field. In addition, it is also specified to assist a designer to comply with UL1950, IEC950 and CSA C22.2. It is UL 497B approved (file E136224), and has UL94-V0 resin approved

TM: ASD is trademarks of STMicroelectronics.

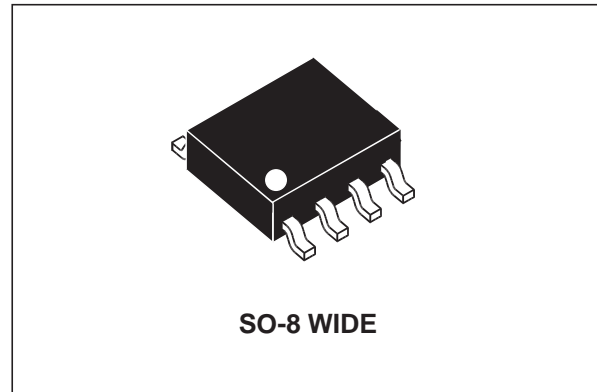

### FUNCTIONAL DIAGRAM

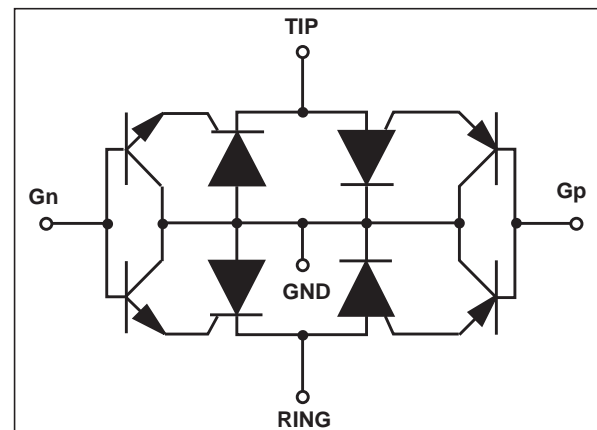

### PIN-OUT CONFIGURATION

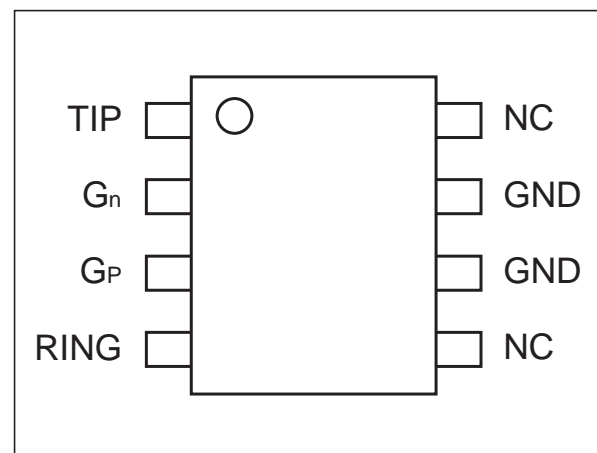

## LCP02-150B1

### COMPLIES WITH FOLLOWING STANDARDS

	Peak surge voltage (V)	Voltage waveform ( $\mu$ s)	Required peak current (A)	Current waveform ( $\mu$ s)	Minimum serial resistor to meet standard ( $\Omega$ )
ITU-T K20	4000 1000	10/700 10/700	100 25	5/310 5/310	50 0
ITU-T K21	4000 1500	10/700 10/700	100 37.5	5/310 5/310	50 0
VDE0433	2000	10/700	50	5/310	5
VDE0878	2000	1.2/50	50	1/20	0
IEC61000-4-5	level 3 level 4	10/700 1.2/50	50 100	5/310 8/20	5 25
FCC Part 68 lightning surge type A	1500 800	10/160 10/560	200 100	10/160 10/560	20 15
FCC Part 68 lightning surge type B	1000	9/720	25	5/320	0
BELLCORE GR-1089-CORE First level	2500 1000	2/10 10/1000	500 100	2/10 10/1000	20 25
BELLCORE GR-1089-CORE Second level	5000	2/10	500	2/10	40
BELLCORE GR-1089-CORE Intrabuilding	800 1500	2/10 2/10	100 100	2/10 2/10	0 0

### ABSOLUTE MAXIMUM RATINGS ( $T_{amb} = 25\text{ }^{\circ}\text{C}$ )

Symbol	Parameter	Value	Unit
$I_{PP}$	Peak pulse current	10/1000 $\mu$ s 5/310 $\mu$ s 1/20 $\mu$ s	30 45 65 A
$I_{TSM}$	Non repetitive surge peak on-state current (F = 50Hz)	$t_p = 0.2\text{ s}$ $t_p = 1\text{ s}$ $t_p = 15\text{ min}$	5.5 4.2 1.5 A
$V_{GN\text{ max}}$ $V_{GP\text{ max}}$ $\Delta V_{bat\text{ max}}$	Maximum negative battery voltage range Maximum positive battery voltage range Total battery supply voltage	See fig.1	-110 to 0 0 to +95 190 V
$T_{op}$	Operating temperature range (see note 1)		-20 to +85 $^{\circ}\text{C}$
$T_{stg}$	Storage temperature range		- 55 to + 150 $^{\circ}\text{C}$
$T_L$	Lead solder temperature (10s duration)		260 $^{\circ}\text{C}$

**Note 1:** Within the  $T_{op}$  range, the LCP02-150B1 keeps on operating. The impacts of the ambient temperature are given by derating curves.

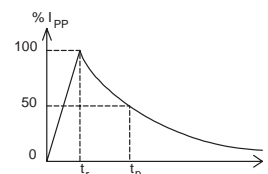
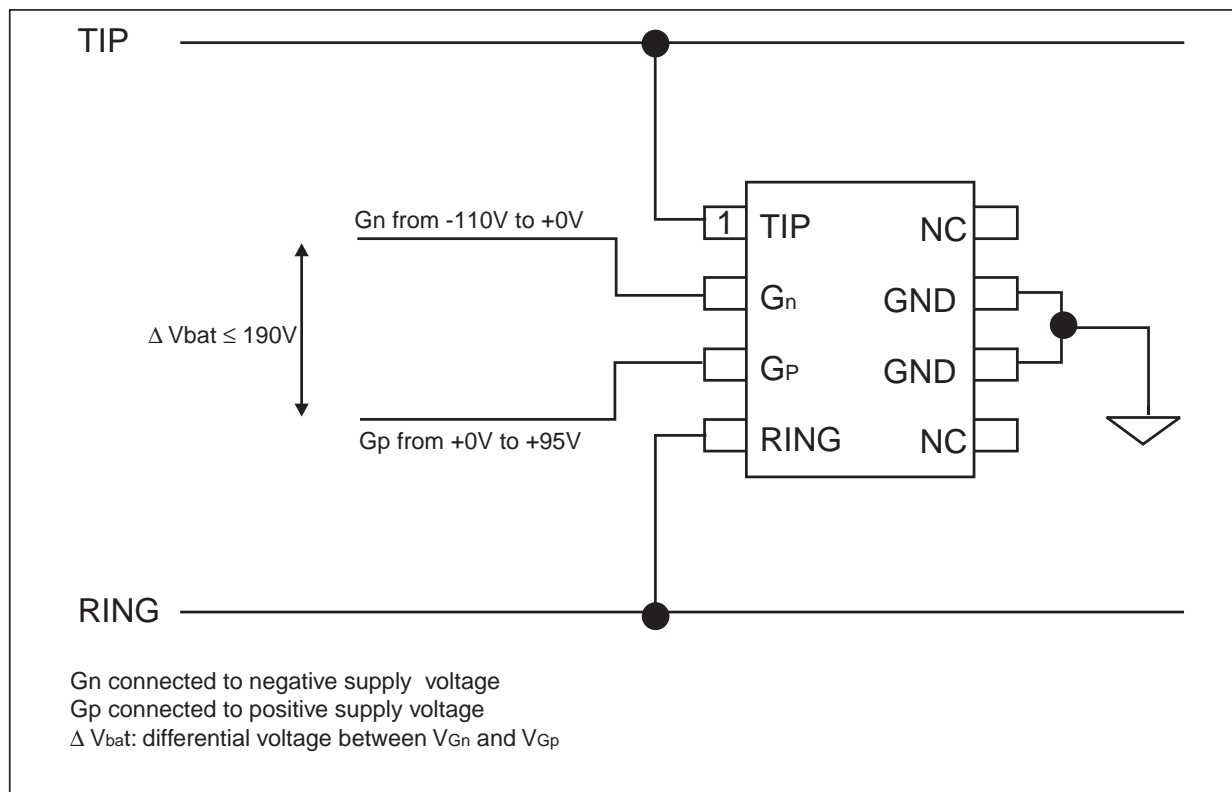

Fig. 1: Test circuit



## THERMAL RESISTANCE

Symbol	Parameter	Value	Unit
$R_{th(j-a)}$	Junction to ambient	150	$^{\circ}C/W$

## LCP02-150B1

### ELECTRICAL CHARACTERISTICS ( $T_{amb} = 25^{\circ}\text{C}$ )

#### 1 - PARAMETERS RELATED TO THE NEGATIVE SUPPRESSOR

Symbol	Parameter	Test conditions	Min.	Max.	Unit
$I_{Gn}$	Negative gate trigger current	$V_{Gn/GND} = -60\text{V}$ Measured at 50Hz		5	mA
$I_{H-}$	Holding current (see fig.2)	Go-No Go test, $V_{Gn} = -60\text{V}$	150		mA
$I_{RGL-}$	Reverse leakage current Gn/Line	$T_j = 25^{\circ}\text{C}$ , $V_{Gn/line} = -190\text{V}$		5	$\mu\text{A}$
$V_{DGL-}$	Dynamic switching voltage Gn / Line (see note 2)	$V_{Gn/GND} = -60\text{V}$ 10/1000 $\mu\text{s}$ 1kV $R_P = 25\Omega$ $I_{PP} = 30\text{A}$ 10/700 $\mu\text{s}$ 2kV $R_P = 25\Omega$ $I_{PP} = 30\text{A}$ 1.2/50 $\mu\text{s}$ 2kV $R_P = 25\Omega$ $I_{PP} = 30\text{A}$		18 8 15	V

#### 2 - PARAMETERS RELATED TO THE POSITIVE SUPPRESSOR

Symbol	Parameter	Test conditions	Min.	Max.	Unit
$I_{Gp}$	Positive gate trigger current	$V_{Gp/GND} = 60\text{V}$ Measured at 50Hz		5	mA
$I_{RGL+}$	Reverse leakage current Gp/LINE	$T_j = 25^{\circ}\text{C}$ , $V_{Gp/line} = +190\text{V}$		5	$\mu\text{A}$
$V_{DGL+}$	Dynamic switching voltage Gp / Line (see note 2)	$V_{Gp/GND} = +60\text{V}$ 10/1000 $\mu\text{s}$ 1kV $R_P = 25\Omega$ $I_{PP} = 30\text{A}$ 10/700 $\mu\text{s}$ 2kV $R_P = 25\Omega$ $I_{PP} = 30\text{A}$ 1.2/50 $\mu\text{s}$ 2kV $R_P = 25\Omega$ $I_{PP} = 30\text{A}$		18 8 35	V

#### 3 - PARAMETERS RELATED TO LINE/GND

Symbol	Parameter	Test conditions	Typ.	Max.	Unit
$I_R$	Reverse leakage current	$T_j = 25^{\circ}\text{C}$ , $V_{LINE} = +90\text{V}$ , $V_{GP/LINE} = +1\text{V}$ $T_j = 25^{\circ}\text{C}$ , $V_{LINE} = -105\text{V}$ , $V_{GN/LINE} = -1\text{V}$		5 5	$\mu\text{A}$
$C_{off}$	Capacitance LINE/GND	$V_R = -3\text{V}$ , $F = 1\text{MHz}$ , $V_{Gp} = 60\text{V}$ , $V_{Gn} = -60\text{V}$	60		pF

**Note 2:** The  $V_{DGL}$  value is the difference between the peak line voltage during the surge and the programmed gate voltage.

**Fig. 2:** Relative variation of holding current versus junction temperature.

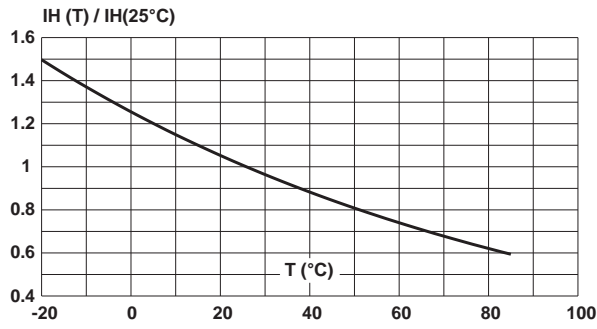

**Fig. 3:** Maximum non repetitive surge peak on state current versus overload duration (with 50Hz sinusoidal wave and initial junction temperature equal to +25°C).

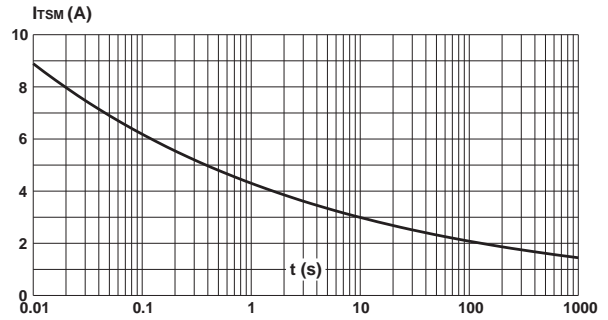

**Fig. 4:** Capacitance versus reverse applied voltage (typical values) with  $V_{GN} = -90\text{V}$  and  $V_{GP} = +90\text{V}$ .

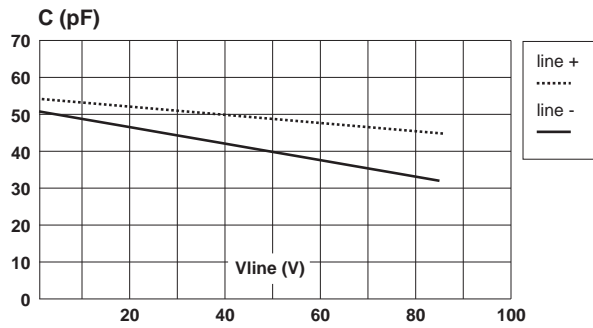

# LCP02-150B1

## TECHNICAL INFORMATION

Fig. 5: LCP02 concept behavior.

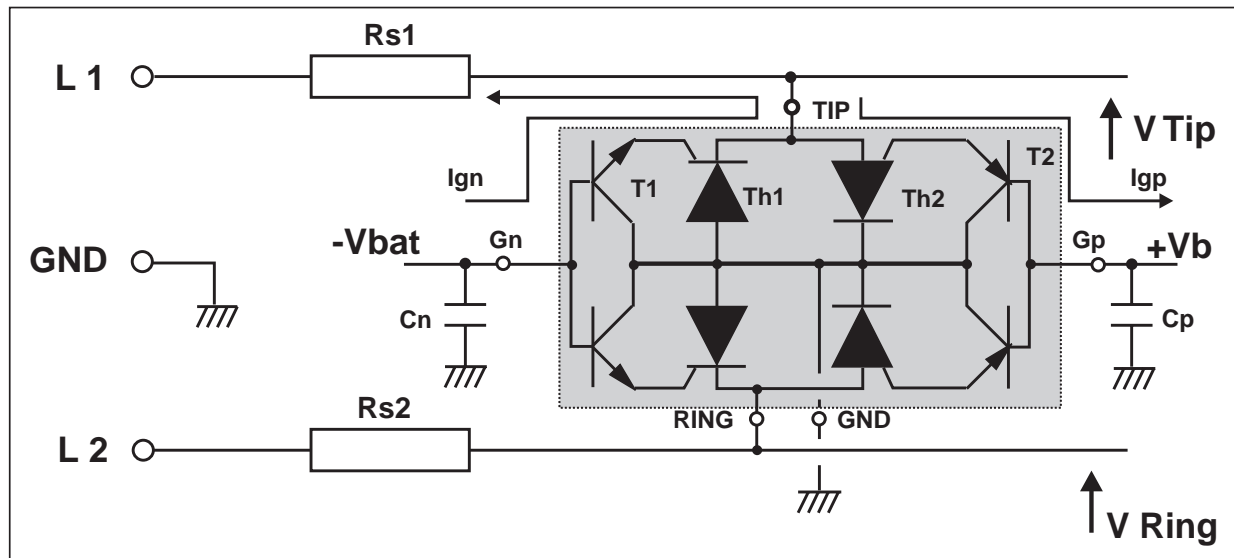

Figure 5 shows the classical protection circuit using the LCP02 crowbar concept. This topology has been developed to protect the new two-battery voltage SLICs. It allows both positive and negative firing thresholds to be programmed. The LCP02-150B1 has two gates (Gn and Gp). Gn is biased to negative battery voltage -Vbat, while Gp is biased to the positive battery voltage +Vb.

When a negative surge occurs on one wire (L1 for example), a current  $I_{gn}$  flows through the base of the transistor T1 and then injects a current in the gate of the thyristor Th1 which fires. All the surge current flows through the ground. After the surge, when the current flowing through Th1 becomes less negative than the negative holding current  $I_{H-}$ , Th1 switches off. This holding current  $I_{H-}$  is temperature dependant as per figure 2.

When a positive surge occurs on one wire (L1 for example), a current  $I_{gp}$  flows through the base of the transistor T2 and then injects a current in the gate of the thyristor Th2 which fires. All the surge current flows through the ground. After the surge, when the current flowing through Th2 becomes less positive than the positive holding current  $I_{H+}$ , Th2 switches off. This holding current  $I_{H+}$ , typically 20mA at 25°C, is temperature dependant and the same figure 2 also applies.

The capacitors Cn and Cp are used to speed up the crowbar structure firing during the fast rise or fall edges. This allows to minimize the dynamical breakover voltage at the SLIC Tip and Ring inputs during fast surges. Please note that these capacitors are generally available around the SLIC. To be efficient they have to be as close as possible to the LCP02-150B1 gate pins (Gn and Gp) and to the reference ground track (or plan). The optimized value for Cn and Cp is 220nF.

The series resistors Rs1 and Rs2 designed in figure 5 represent the fuse resistors or the PTCs which are needed to withstand the power contact or the power induction tests imposed by the country standards. Taking this factor into account, the actual lightning surge current flowing through the LCP02-150B1 is equal to :

$$I_{\text{surge}} = V_{\text{surge}} / (R_g + R_s)$$

With  $V_{\text{surge}}$  = peak surge voltage imposed by the standard.  
 $R_g$  = series resistor of the surge generator  
 $R_s$  = series resistor of the line card (e.g. PTC)

*e.g.* : For a line card with 50Ω of series resistors which has to be qualified under Bellcore 1000V 10/1000μs surge, the present current through the LCP02-150B1 is equal to :

$$I_{\text{surge}} = 1000 / (10 + 50) = \mathbf{17A}$$



# LCP02-150B1

## PACKAGE MECHANICAL DATA

### SO-8 Wide Plastic

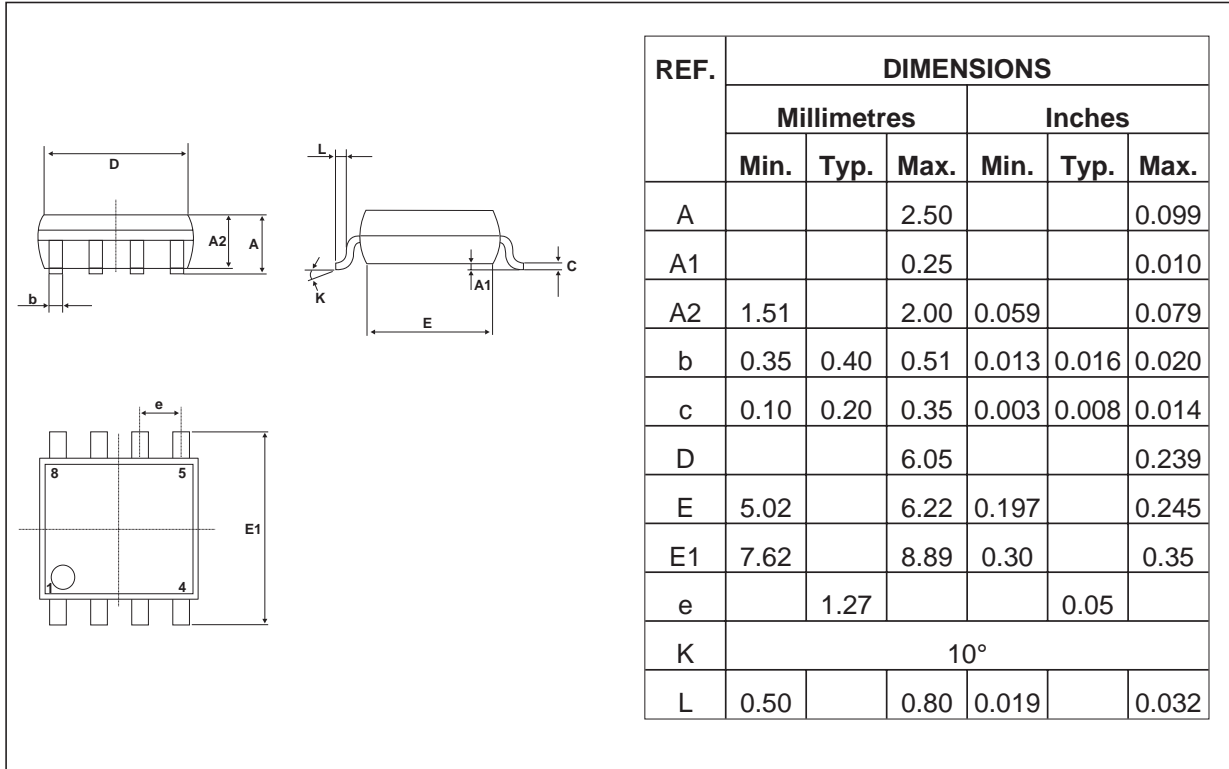

## ORDER CODE

Ordering Type	Marking	Package	Weight	Base qty	Delivery mode
LCP02-150B1	LCP02	SO-8-Wide	0.13g	90	Tube
LCP02-150B1RL				1500	Tape & Reel

Information furnished is believed to be accurate and reliable. However, STMicroelectronics assumes no responsibility for the consequences of use of such information nor for any infringement of patents or other rights of third parties which may result from its use. No license is granted by implication or otherwise under any patent or patent rights of STMicroelectronics. Specifications mentioned in this publication are subject to change without notice. This publication supersedes and replaces all information previously supplied. STMicroelectronics products are not authorized for use as critical components in life support devices or systems without express written approval of STMicroelectronics.



The ST logo is a registered trademark of STMicroelectronics  
 © 2000 STMicroelectronics - Printed in Italy - All rights reserved.

STMicroelectronics GROUP OF COMPANIES  
 Australia - Brazil - China - Finland - France - Germany - Hong Kong - India - Italy - Japan - Malaysia  
 Malta - Morocco - Singapore - Spain - Sweden - Switzerland - United Kingdom - U.S.A.

<http://www.st.com>

## Looking for pricing, stock, or lifecycle information?

Click below to explore more details on WIN SOURCE:

-  [View LCP02-150B1](#) on WIN SOURCE
-  [STMicroelectronics](#) Information

## Optimize Your Supply Chain with WIN SOURCE Solutions

-  Global Sourcing Solution
-  Obsolete Management
-  Cost Control Management
-  Shortage Management
-  Alternative Solution
-  Excess Inventory Management