



# MPC8272

## PowerQUICC II Family

### Hardware Specifications

This document contains detailed information about power considerations, DC/AC electrical characteristics, and AC timing specifications for .13 $\mu$ m (HiP7) members of the PowerQUICC II family of integrated communications processors—the MPC8272, the MPC8248, the MPC8271, and the MPC8247. They include on a single chip a 32-bit Power Architecture® core that incorporates memory management units (MMUs) and instruction and data caches and that implements the Power Architecture instruction set; a modified communications processor module (CPM); and an integrated security engine (SEC) for encryption (the MPC8272 and the MPC8248 only).

All four devices are collectively referred to throughout this hardware specification as “the MPC8272” unless otherwise noted.

#### Contents

1. Overview .....	2
2. Operating Conditions .....	7
3. DC Electrical Characteristics .....	9
4. Thermal Characteristics .....	14
5. Power Dissipation .....	17
6. AC Electrical Characteristics .....	18
7. Clock Configuration Modes .....	27
8. Pinout .....	43
9. Package Description .....	56
10. Ordering Information .....	58
11. Document Revision History .....	58

# 1 Overview

This table shows the functionality supported by each SoC in the MPC8272 family.

**Table 1. MPC8272 PowerQUICC II Family Functionality**

Functionality	Package <sup>1</sup>	SoCs			
		MPC8272	MPC8248	MPC8271	MPC8247
		516 PBGA			
Serial communications controllers (SCCs)		3	3	3	3
QUICC multi-channel controller (QMC)		Yes	Yes	Yes	Yes
Fast communication controllers (FCCs)		2	2	2	2
I-Cache (Kbyte)		16	16	16	16
D-Cache (Kbyte)		16	16	16	16
Ethernet (10/100)		2	2	2	2
UTOPIA II Ports		1	0	1	0
Multi-channel controllers (MCCs)		0	0	0	0
PCI bridge		Yes	Yes	Yes	Yes
Transmission convergence (TC) layer		—	—	—	—
Inverse multiplexing for ATM (IMA)		—	—	—	—
Universal serial bus (USB) 2.0 full/low rate		1	1	1	1
Security engine (SEC)		Yes	Yes	—	—

<sup>1</sup> See [Table 2](#).

Devices in the MPC8272 family are available in two packages—the VR or ZQ package—as shown in . For package ordering information, see [Section 10, “Ordering Information.”](#)

**Table 2. MPC8272 PowerQUICC II Device Packages**

Code (Package)	VR (516 PBGA—Lead free)	ZQ (516 PBGA—Lead spheres)
Device	MPC8272VR	MPC8272ZQ
	MPC8248VR	MPC8248ZQ
	MPC8271VR	MPC8271ZQ
	MPC8247VR	MPC8247ZQ

This figure shows the block diagram of the SoC.

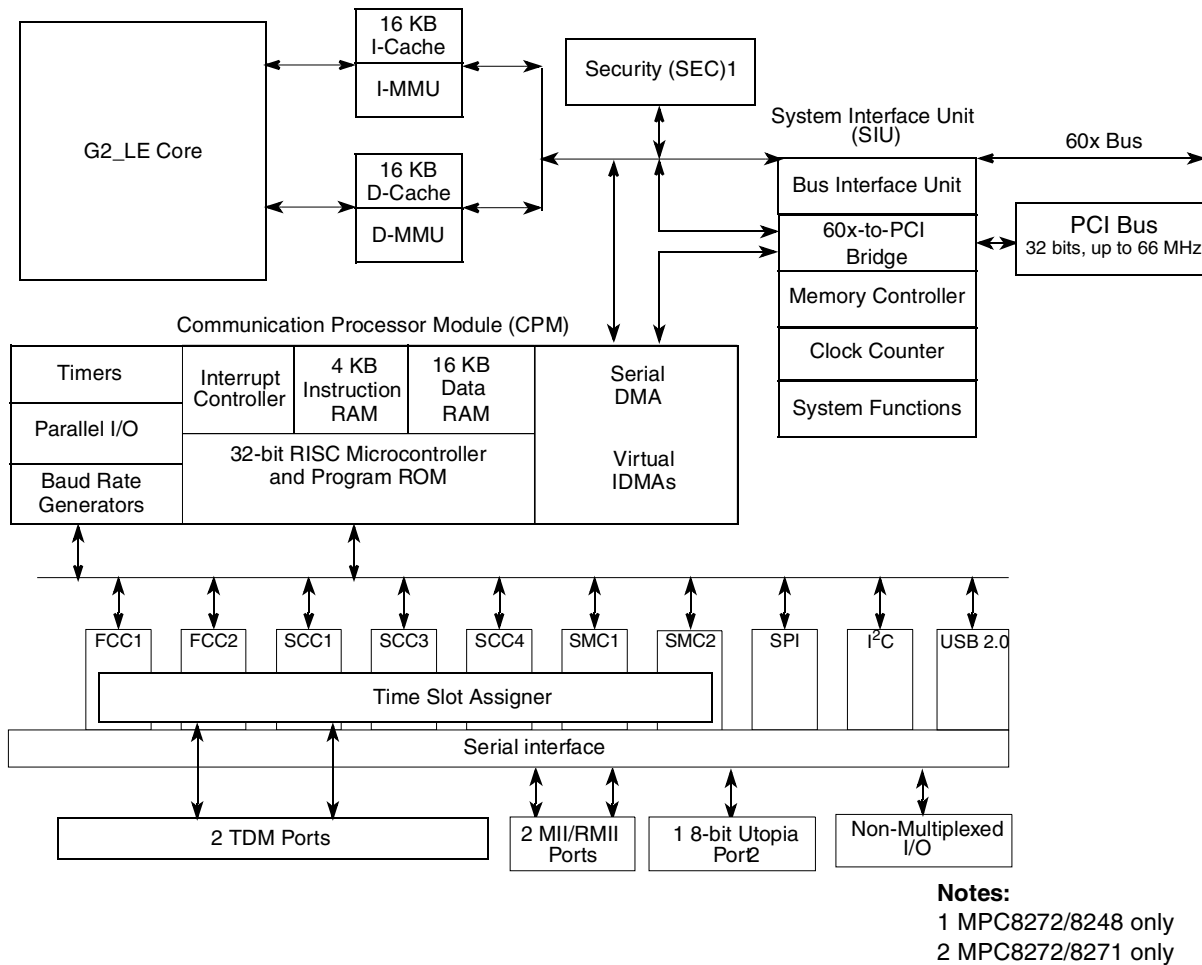

Figure 1. SoC Block Diagram

## 1.1 Features

The major features of the SoC are as follows:

- Dual-issue integer (G2\_LE) core
  - A core version of the MPC603e microprocessor
  - System core microprocessor supporting frequencies of 266–400 MHz
  - Separate 16 KB data and instruction caches:
    - Four-way set associative
    - Physically addressed
    - LRU replacement algorithm
  - Power Architecture®-compliant memory management unit (MMU)
  - Common on-chip processor (COP) test interface
  - Supports bus snooping for cache coherency

- Floating-point unit (FPU) supports floating-point arithmetic
- Support for cache locking
- Low-power consumption
- Separate power supply for internal logic (1.5 V) and for I/O (3.3 V)
- Separate PLLs for G2\_LE core and for the communications processor module (CPM)
  - G2\_LE core and CPM can run at different frequencies for power/performance optimization
  - Internal core/bus clock multiplier that provides ratios 2:1, 2.5:1, 3:1, 3.5:1, 4:1, 4.5:1, 5:1, 5.5:1, 6:1, 7:1, 8:1
  - Internal CPM/bus clock multiplier that provides ratios 2:1, 2.5:1, 3:1, 3.5:1, 4:1, 5:1, 6:1, 8:1 ratios
- 64-bit data and 32-bit address 60x bus
  - Bus supports multiple master designs—up to two external masters
  - Supports single transfers and burst transfers
  - 64-, 32-, 16-, and 8-bit port sizes controlled by on-chip memory controller
- 60x-to-PCI bridge
  - Programmable host bridge and agent
  - 32-bit data bus, 66 MHz, 3.3 V
  - Synchronous and asynchronous 60x and PCI clock modes
  - All internal address space available to external PCI host
  - DMA for memory block transfers
    - PCI-to-60x address remapping
- System interface unit (SIU)
  - Clock synthesizer
  - Reset controller
  - Real-time clock (RTC) register
  - Periodic interrupt timer
  - Hardware bus monitor and software watchdog timer
  - IEEE 1149.1 JTAG test access port
- Eight bank memory controller
  - Glueless interface to SRAM, page mode SDRAM, DRAM, EPROM, Flash, and other user-definable peripherals
  - Byte write enables
  - 32-bit address decodes with programmable bank size
  - Three user-programmable machines, general-purpose chip-select machine, and page mode pipeline SDRAM machine
  - Byte selects for 64-bit bus width (60x)
  - Dedicated interface logic for SDRAM
- Disable CPU mode

- Integrated security engine (SEC) (MPC8272 and MPC8248 only)
  - Supports DES, 3DES, MD-5, SHA-1, AES, PKEU, RNG and RC-4 encryption algorithms in hardware
- Communications processor module (CPM)
  - Embedded 32-bit communications processor (CP) uses a RISC architecture for flexible support for communications peripherals
  - Interfaces to G2\_LE core through on-chip dual-port RAM and DMA controller. (Dual-port RAM size is 16 KB plus 4 KB dedicated instruction RAM.)
  - Microcode tracing capabilities
  - Eight CPM trap registers
- Universal serial bus (USB) controller
  - Supports USB 2.0 full/low rate compatible
  - USB host mode
    - Supports control, bulk, interrupt, and isochronous data transfers
    - CRC16 generation and checking
    - NRZI encoding/decoding with bit stuffing
    - Supports both 12- and 1.5-Mbps data rates (automatic generation of preamble token and data rate configuration). Note that low-speed operation requires an external hub.
    - Flexible data buffers with multiple buffers per frame
    - Supports local loopback mode for diagnostics (12 Mbps only)
  - Supports USB slave mode
    - Four independent endpoints support control, bulk, interrupt, and isochronous data transfers
    - CRC16 generation and checking
    - CRC5 checking
    - NRZI encoding/decoding with bit stuffing
    - 12- or 1.5-Mbps data rate
    - Flexible data buffers with multiple buffers per frame
    - Automatic retransmission upon transmit error
  - Serial DMA channels for receive and transmit on all serial channels
  - Parallel I/O registers with open-drain and interrupt capability
  - Virtual DMA functionality executing memory-to-memory and memory-to-I/O transfers
  - Two fast communication controllers (FCCs) supporting the following protocols:
    - 10-/100-Mbit Ethernet/IEEE 802.3 CDMA/CS interface through media independent interface (MII)
    - Transparent
    - HDLC—up to T3 rates (clear channel)

- One of the FCCs supports ATM (MPC8272 and MPC8271 only)—full-duplex SAR at 155 Mbps, 8-bit UTOPIA interface 31 Mphys, AAL5, AAL1, AAL2, AAL0 protocols, TM 4.0 CBR, VBR, UBR, ABR traffic types, up to 64-K external connections
- Three serial communications controllers (SCCs) identical to those on the MPC860 supporting the digital portions of the following protocols:
  - Ethernet/IEEE 802.3 CDMA/CS
  - HDLC/SDLC and HDLC bus
  - Universal asynchronous receiver transmitter (UART)
  - Synchronous UART
  - Binary synchronous (BiSync) communications
  - Transparent
  - QUICC multichannel controller (QMC) up to 64 channels
    - Independent transmit and receive routing, frame synchronization.
    - Serial-multiplexed (full-duplex) input/output 2048, 1544, and 1536 Kbps PCM highways
    - Compatible with T1/DS1 24-channel and CEPT E1 32-channel PCM highway, ISDN basic rate, ISDN primary rate, and user defined.
    - Subchanneling on each time slot.
    - Independent transmit and receive routing, frame synchronization and clocking
    - Concatenation of any not necessarily consecutive time slots to channels independently for receiver/transmitter
    - Supports H1, H11, and H12 channels
    - Allows dynamic allocation of channels
  - SCC3 in NMSI mode is not usable when USB is enabled.
- Two serial management controllers (SMCs), identical to those of the MPC860
  - Provides management for BRI devices as general-circuit interface (GCI) controllers in time-division-multiplexed (TDM) channels
  - Transparent
  - UART (low-speed operation)
- One serial peripheral interface identical to the MPC860 SPI
- One I<sup>2</sup>C controller (identical to the MPC860 I<sup>2</sup>C controller)
  - Microwire compatible
  - Multiple-master, single-master, and slave modes
- Up to two TDM interfaces
  - Supports one groups of two TDM channels
  - 1024 bytes of SI RAM
- Eight independent baud rate generators and 14 input clock pins for supplying clocks to FCC, SCC, SMC, and USB serial channels
- Four independent 16-bit timers that can be interconnected as two 32-bit timers

- PCI bridge
  - PCI Specification revision 2.2-compliant and supports frequencies up to 66 MHz
  - On-chip arbitration
  - Support for PCI to 60x memory and 60x memory to PCI streaming
  - PCI host bridge or peripheral capabilities
  - Includes four DMA channels for the following transfers:
    - PCI-to-60x to 60x-to-PCI
    - 60x-to-PCI to PCI-to-60x
    - PCI-to-60x to PCI-to-60x
    - 60x-to-PCI to 60x-to-PCI
  - Includes the configuration registers required by the PCI standard (which are automatically loaded from the EPROM to configure the MPC8272) and message and doorbell registers
  - Supports the I<sub>2</sub>O standard
  - Hot-Swap friendly (supports the Hot Swap Specification as defined by PICMG 2.1 R1.0 August 3, 1998)
  - Support for 66 MHz, 3.3 V specification
  - 60x-PCI bus core logic, which uses a buffer pool to allocate buffers for each port

## 2 Operating Conditions

This table shows the maximum electrical ratings.

**Table 3. Absolute Maximum Ratings<sup>1</sup>**

Rating	Symbol	Value	Unit
Core supply voltage <sup>2</sup>	VDD	-0.3 – 2.25	V
PLL supply voltage <sup>2</sup>	VCCSYN	-0.3 – 2.25	V
I/O supply voltage <sup>3</sup>	VDDH	-0.3 – 4.0	V
Input voltage <sup>4</sup>	VIN	GND(-0.3) – 3.6	V
Junction temperature	T <sub>j</sub>	120	°C
Storage temperature range	T <sub>STG</sub>	(-55) – (+150)	°C

<sup>1</sup> Absolute maximum ratings are stress ratings only; functional operation (see [Table 4](#)) at the maximums is not guaranteed. Stress beyond those listed may affect device reliability or cause permanent damage.

<sup>2</sup> **Caution:** VDD/VCCSYN must not exceed VDDH by more than 0.4 V during normal operation. It is recommended that VDD/VCCSYN should be raised before or simultaneous with VDDH during power-on reset. VDD/VCCSYN may exceed VDDH by more than 0.4 V during power-on reset for no more than 100 ms.

<sup>3</sup> **Caution:** VDDH can exceed VDD/VCCSYN by 3.3 V during power on reset by no more than 100 mSec. VDDH should not exceed VDD/VCCSYN by more than 2.5 V during normal operation.

<sup>4</sup> **Caution:** VIN must not exceed VDDH by more than 2.5 V at any time, including during power-on reset.

This table lists recommended operational voltage conditions.

**Table 4. Recommended Operating Conditions<sup>1</sup>**

Rating	Symbol	Value	Unit
Core supply voltage	VDD	1.425 – 575	V
PLL supply voltage	VCCSYN	1.425 – 575	V
I/O supply voltage	VDDH	3.135 – 3.465	V
Input voltage	VIN	GND (–0.3) – 3.465	V
Junction temperature (maximum)	T <sub>j</sub>	105 <sup>2</sup>	°C
Ambient temperature	T <sub>A</sub>	0–70 <sup>2</sup>	°C

<sup>1</sup> **Caution:** These are the recommended and tested operating conditions. Proper operation outside of these conditions is not guaranteed.

<sup>2</sup> Note that for extended temperature parts the range is  $(-40)_{T_A} - 105_{T_j}$ .

This SoC contains circuitry protecting against damage due to high static voltage or electrical fields; however, it is advised that normal precautions be taken to avoid application of any voltages higher than maximum-rated voltages to this high-impedance circuit. Reliability of operation is enhanced if unused inputs are tied to an appropriate logic voltage level (either GND or V<sub>CC</sub>).

This figure shows the undershoot and overshoot voltage of the 60x bus memory interface of the SoC. Note that in PCI mode the I/O interface is different.

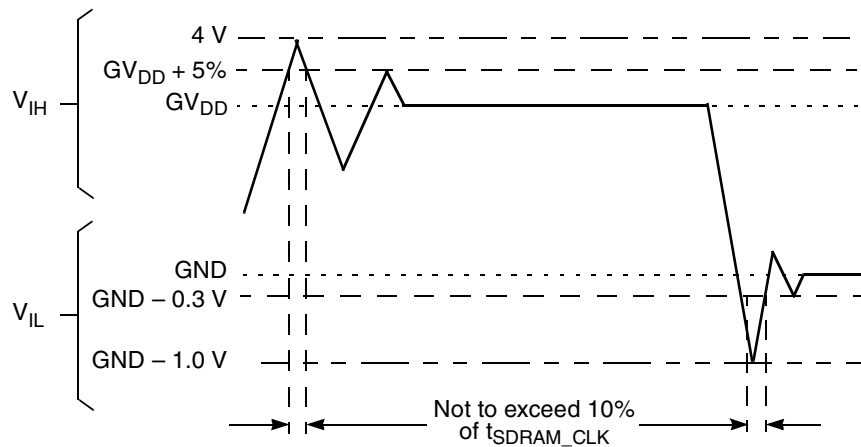

**Figure 2. Overshoot/Undershoot Voltage**

### 3 DC Electrical Characteristics

This table shows DC electrical characteristics.

**Table 5. DC Electrical Characteristics<sup>1</sup>**

Characteristic	Symbol	Min	Max	Unit
Input high voltage—all inputs except TCK, $\overline{\text{TRST}}$ and $\overline{\text{PORESET}}$ <sup>2</sup>	$V_{IH}$	2.0	3.465	V
Input low voltage <sup>3</sup>	$V_{IL}$	GND	0.8	V
CLKIN input high voltage	$V_{IHC}$	2.4	3.465	V
CLKIN input low voltage	$V_{ILC}$	GND	0.4	V
Input leakage current, $V_{IN} = V_{DDH}$ <sup>4</sup>	$I_{IN}$	—	10	$\mu\text{A}$
Hi-Z (off state) leakage current, $V_{IN} = V_{DDH}$ <sup>2</sup>	$I_{OZ}$	—	10	$\mu\text{A}$
Signal low input current, $V_{IL} = 0.8 \text{ V}$	$I_L$	—	1	$\mu\text{A}$
Signal high input current, $V_{IH} = 2.0 \text{ V}$	$I_H$	—	1	$\mu\text{A}$
Output high voltage, $I_{OH} = -2 \text{ mA}$ except UTOPIA mode, and open drain pins  In UTOPIA mode <sup>5</sup> (UTOPIA pins only): $I_{OH} = -8.0 \text{ mA}$ PA[8–31] PB[18–31] PC[0–1,4–29] PD[7–25, 29–31]	$V_{OH}$	2.4	—	V
In UTOPIA mode <sup>5</sup> (UTOPIA pins only): $I_{OL} = 8.0 \text{ mA}$ PA[8–31] PB[18–31] PC[0–1,4–29] PD[7–25, 29–31]	$V_{OL}$	—	0.5	V

Table 5. DC Electrical Characteristics<sup>1</sup> (continued)

Characteristic	Symbol	Min	Max	Unit
$I_{OL} = 6.0\text{mA}$ $\overline{\text{BR}}$ $\overline{\text{BG/IRQ6}}$ $\overline{\text{ABB/IRQ2}}$ $\overline{\text{TS}}$ $\text{A}[0-31]$ $\text{TT}[0-4]$ $\overline{\text{TBST}}$ $\overline{\text{TSIZE}[0-3]}$ $\overline{\text{AACK}}$ $\overline{\text{ARTRY}}$ $\overline{\text{DBG/IRQ7}}$ $\overline{\text{DBB/IRQ3}}$ $\text{D}[0-63]$ $\overline{\text{IRQ3/CKSTP\_OUT/EXT\_BR3}}$ $\overline{\text{IRQ4/CORE\_SRESET/EXT\_BG3}}$ $\overline{\text{IRQ5/TBEN/EXT\_DBG3/CINT}}$ $\overline{\text{PSDVAL}}$ $\overline{\text{TA}}$ $\overline{\text{TEA}}$ $\overline{\text{GBL/IRQ1}}$ $\overline{\text{CI/BADDR29/IRQ2}}$ $\overline{\text{WT/BADDR30/IRQ3}}$ $\overline{\text{BADDR31/IRQ5/CINT}}$ $\overline{\text{CPU\_BR/INT\_OUT}}$ $\overline{\text{IRQ0/NMI\_OUT}}$ $\overline{\text{PORESET/PCI\_RST}}$ $\overline{\text{HRESET}}$ $\overline{\text{SRESET}}$ $\overline{\text{RSTCONF}}$	$V_{OL}$	—	0.4	V

Table 5. DC Electrical Characteristics<sup>1</sup> (continued)

Characteristic	Symbol	Min	Max	Unit
$I_{OL} = 5.3\text{mA}$ $\overline{CS}[0-5]$ $\overline{CS6}/\overline{BCTL1}/\overline{SMI}$ $\overline{CS7}/\overline{TLBSYNC}$ $\overline{BADDR27}/\overline{IRQ1}$ $\overline{BADDR28}/\overline{IRQ2}$ $\overline{ALE}/\overline{IRQ4}$ $\overline{BCTL0}$ $\overline{PWE}[0-7]/\overline{PSDDQM}[0-7]/\overline{PBS}[0-7]$ $\overline{PSDA10}/\overline{PGPL0}$ $\overline{PSDWE}/\overline{PGPL1}$ $\overline{POE}/\overline{PSDRAS}/\overline{PGPL2}$ $\overline{PSDCAS}/\overline{PGPL3}$ $\overline{PGTA}/\overline{PUPMWAIT}/\overline{PGPL4}$ $\overline{PSDAMUX}/\overline{PGPL5}$ $\overline{PCI\_CFG0} (\overline{PCI\_HOST\_EN})$ $\overline{PCI\_CFG1} (\overline{PCI\_ARB\_EN})$ $\overline{PCI\_CFG2} (\overline{DLL\_ENABLE})$ $\overline{MODCK1}/\overline{RSRV}/\overline{TC}(0)/\overline{BNKSEL}(0)$ $\overline{MODCK2}/\overline{CSE0}/\overline{TC}(1)/\overline{BNKSEL}(1)$ $\overline{MODCK3}/\overline{CSE1}/\overline{TC}(2)/\overline{BNKSEL}(2)$ $I_{OL} = 3.2\text{mA}$ $\overline{PCI\_PAR}$ $\overline{PCI\_FRAME}$ $\overline{PCI\_TRDY}$ $\overline{PCI\_IRDY}$ $\overline{PCI\_STOP}$ $\overline{PCI\_DEVSEL}$ $\overline{PCI\_IDSEL}$ $\overline{PCI\_PERR}$ $\overline{PCI\_SERR}$ $\overline{PCI\_REQ0}$ $\overline{PCI\_REQ1}/\overline{CPI\_HS\_ES}$ $\overline{PCI\_GNT0}$ $\overline{PCI\_GNT1}/\overline{CPI\_HS\_LES}$ $\overline{PCI\_GNT2}/\overline{CPI\_HS\_ENUM}$ $\overline{PCI\_RST}$ $\overline{PCI\_INTA}$ $\overline{PCI\_REQ2}$ $\overline{DLLOUT}$ $\overline{PCI\_AD}(0-31)$ $\overline{PCI\_C}(0-3)/\overline{BE}(0-3)$ $\overline{PA}[8-31]$ $\overline{PB}[18-31]$ $\overline{PC}[0-1,4-29]$ $\overline{PD}[7-25, 29-31]$ $\overline{TDO}$	$V_{OL}$	—	0.4	V

<sup>1</sup> The default configuration of the CPM pins ( $\overline{PA}[8-31]$ ,  $\overline{PB}[18-31]$ ,  $\overline{PC}[0-1,4-29]$ ,  $\overline{PD}[7-25, 29-31]$ ) is input. To prevent excessive DC current, it is recommended either to pull unused pins to GND or VDDH, or to configure them as outputs.

<sup>2</sup>  $\overline{TCK}$ ,  $\overline{TRST}$  and  $\overline{PORESET}$  have min  $V_{IH} = 2.5\text{V}$ .

<sup>3</sup>  $V_{IL}$  for IIC interface does not match IIC standard, but does meet IIC standard for  $V_{OL}$  and should not cause any compatibility issue.

<sup>4</sup> The leakage current is measured for nominal VDDH, VCCSYN, and VDD.

DC Electrical Characteristics

<sup>5</sup> MPC8272 and MPC8271 only.

Table 6.

Characteristic	Symbol	Min	Max	Unit
Input high voltage—all inputs except TCK, TRST and PORESET <sup>1</sup>	V <sub>IH</sub>	2.0	3.465	V
Input low voltage	V <sub>IL</sub>	GND	0.8	V
CLKIN input high voltage	V <sub>IHC</sub>	2.4	3.465	V
CLKIN input low voltage	V <sub>ILC</sub>	GND	0.4	V
Input leakage current, V <sub>IN</sub> = VDDH <sup>2</sup>	I <sub>IN</sub>	—	10	μA
Hi-Z (off state) leakage current, V <sub>IN</sub> = VDDH <sup>2</sup>	I <sub>OZ</sub>	—	10	μA
Signal low input current, V <sub>IL</sub> = 0.8 V <sup>3</sup>	I <sub>L</sub>	—	1	μA
Signal high input current, V <sub>IH</sub> = 2.0 V	I <sub>H</sub>	—	1	μA
Output high voltage, I <sub>OH</sub> = -2 mA except UTOPIA mode, and open drain pins  In UTOPIA mode <sup>4</sup> (UTOPIA pins only): I <sub>OH</sub> = -8.0mA	V <sub>OH</sub>	2.4	—	V
In UTOPIA mode <sup>4</sup> (UTOPIA pins only): I <sub>OL</sub> = 8.0mA	V <sub>OL</sub>	—	0.5	V
I <sub>OL</sub> = 6.0mA BR BG ABB/IRQ2 TS A[0-31] TT[0-4] TBST TSIZE[0-3] AACK ARTRY DBG DBB/IRQ3 D[0-63] //EXT_BR3 //EXT_BG3 /TBEN/EXT_DBG3/CINT PSDVAL TA TEA GBL/IRQ1 CI/BADDR29/IRQ2 WT/BADDR30/IRQ3 BADDR31/IRQ5/CINT CPU_BR IRQ0/NMI_OUT /PCI_RST HRESET SRESET RSTCONF	V <sub>OL</sub>	—	0.4	V

Table 6.

Characteristic	Symbol	Min	Max	Unit
$I_{OL} = 5.3\text{mA}$ $\overline{CS}[0-9]$ $\overline{CS}(10)/\overline{BCTL1}$ $\overline{CS}(11)/\overline{AP}(0)$ $\overline{BADDR}[27-28]$ $\overline{ALE}$ $\overline{BCTL0}$ $\overline{PWE}[0-7]/\overline{PSDDQM}[0-7]/\overline{PBS}[0-7]$ $\overline{PSDA10}/\overline{PGPL0}$ $\overline{PSDWE}/\overline{PGPL1}$ $\overline{POE}/\overline{PSDRAS}/\overline{PGPL2}$ $\overline{PSDCAS}/\overline{PGPL3}$ $\overline{PGTA}/\overline{PUPMWAIT}/\overline{PGPL4}/\overline{PPBS}$ $\overline{PSDAMUX}/\overline{PGPL5}$ $\overline{LWE}[0-3]/\overline{LSDDQM}[0-3]/\overline{LBS}[0-3]/\overline{PCI\_CFG}[0-3]$ $\overline{LSDA10}/\overline{LGPL0}/\overline{PCI\_MODCKH0}$ $\overline{LSDWE}/\overline{LGPL1}/\overline{PCI\_MODCKH1}$ $\overline{LOE}/\overline{LSDRAS}/\overline{LGPL2}/\overline{PCI\_MODCKH2}$ $\overline{LSDCAS}/\overline{LGPL3}/\overline{PCI\_MODCKH3}$ $\overline{LGTA}/\overline{LUPMWAIT}/\overline{LGPL4}/\overline{LPBS}$ $\overline{LSDAMUX}/\overline{LGPL5}/\overline{PCI\_MODCK}$ $\overline{LWR}$ $\overline{MODCK}[1-3]/\overline{AP}[1-3]/\overline{TC}[0-2]/\overline{BNKSEL}[0-2]$ $I_{OL} = 3.2\text{mA}$ $\overline{L\_A14}/\overline{PAR}$ $\overline{L\_A15}/\overline{FRAME}/\overline{SMI}$ $\overline{L\_A16}/\overline{TRDY}$ $\overline{L\_A17}/\overline{IRDY}/\overline{CKSTP\_OUT}$ $\overline{L\_A18}/\overline{STOP}$ $\overline{L\_A19}/\overline{DEVSEL}$ $\overline{L\_A20}/\overline{IDSEL}$ $\overline{L\_A21}/\overline{PERR}$ $\overline{L\_A22}/\overline{SERR}$ $\overline{L\_A23}/\overline{REQ0}$ $\overline{L\_A24}/\overline{REQ1}/\overline{HSEJSW}$ $\overline{L\_A25}/\overline{GNT0}$ $\overline{L\_A26}/\overline{GNT1}/\overline{HSLED}$ $\overline{L\_A27}/\overline{GNT2}/\overline{HSENUM}$ $\overline{L\_A28}/\overline{RST}/\overline{CORE\_SRESET}$ $\overline{L\_A29}/\overline{INTAL\_A30}/\overline{REQ2}$ $\overline{L\_A31}$ $\overline{LCL\_D}[0-31]/\overline{AD}[0-31]$ $\overline{LCL\_DP}[03]/\overline{C}/\overline{BE}[0-3]$ $\overline{PA}[0-31]$ $\overline{PB}[4-31]$ $\overline{PC}[0-31]$ $\overline{PD}[4-31]$ $\overline{TDO}$ $\overline{QREQ}$	$V_{OL}$	—	0.4	V

<sup>1</sup> TCK, TRST and PORESET have min  $V_{IH} = 2.5\text{V}$ .

<sup>2</sup> The leakage current is measured for nominal VDDH, VCCSYN, and VDD.

<sup>3</sup>  $V_{IL}$  for IIC interface does not match IIC standard, but does meet IIC standard for  $V_{OL}$  and should not cause any compatibility issue.

<sup>4</sup> MPC8280, MPC8275VR, MPC8275ZQ only.

## 4 Thermal Characteristics

This table describes thermal characteristics. See [Table 2](#) for information on a given SoC's package. Discussions of each characteristic are provided in [Section 4.1, "Estimation with Junction-to-Ambient Thermal Resistance,"](#) through [Section 4.7, "References."](#) For the these discussions,  $P_D = (V_{DD} \times I_{DD}) + PI/O$ , where PI/O is the power dissipation of the I/O drivers.

**Table 7. Thermal Characteristics**

Characteristic	Symbol	Value	Unit	Air Flow
Junction-to-ambient— single-layer board <sup>1</sup>	$R_{\theta JA}$	27	°C/W	Natural convection
		21		1 m/s
Junction-to-ambient— four-layer board	$R_{\theta JA}$	19	°C/W	Natural convection
		16		1 m/s
Junction-to-board <sup>2</sup>	$R_{\theta JB}$	11	°C/W	—
Junction-to-case <sup>3</sup>	$R_{\theta JC}$	8	°C/W	—
Junction-to-package top <sup>4</sup>	$R_{\theta JT}$	2	°C/W	—

<sup>1</sup> Assumes no thermal vias

<sup>2</sup> Thermal resistance between the die and the printed circuit board per JEDEC JESD51-8. Board temperature is measured on the top surface of the board near the package.

<sup>3</sup> Thermal resistance between the die and the case top surface as measured by the cold plate method (MIL SPEC-883 Method 1012.1).

<sup>4</sup> Thermal characterization parameter indicating the temperature difference between package top and the junction temperature per JEDEC JESD51-2. When Greek letters are not available, the thermal characterization parameter is written as Psi-JT.

### 4.1 Estimation with Junction-to-Ambient Thermal Resistance

An estimation of the chip junction temperature,  $T_J$ , in °C can be obtained from the following equation:

$$T_J = T_A + (R_{\theta JA} \times P_D)$$

where:

$T_A$  = ambient temperature (°C)

$R_{\theta JA}$  = package junction-to-ambient thermal resistance (°C/W)

$P_D$  = power dissipation in package

The junction-to-ambient thermal resistance is an industry standard value that provides a quick and easy estimation of thermal performance. However, the answer is only an estimate; test cases have demonstrated that errors of a factor of two (in the quantity  $T_J - T_A$ ) are possible.

## 4.2 Estimation with Junction-to-Case Thermal Resistance

Historically, the thermal resistance has frequently been expressed as the sum of a junction-to-case thermal resistance and a case-to-ambient thermal resistance:

$$R_{\theta JA} = R_{\theta JC} + R_{\theta CA}$$

where:

$R_{\theta JA}$  = junction-to-ambient thermal resistance ( $^{\circ}\text{C}/\text{W}$ )

$R_{\theta JC}$  = junction-to-case thermal resistance ( $^{\circ}\text{C}/\text{W}$ )

$R_{\theta CA}$  = case-to-ambient thermal resistance ( $^{\circ}\text{C}/\text{W}$ )

$R_{\theta JC}$  is device related and cannot be influenced by the user. The user adjusts the thermal environment to affect the case-to-ambient thermal resistance,  $R_{\theta CA}$ . For instance, the user can change the air flow around the device, add a heat sink, change the mounting arrangement on the printed circuit board, or change the thermal dissipation on the printed circuit board surrounding the device. This thermal model is most useful for ceramic packages with heat sinks where some 90% of the heat flows through the case and the heat sink to the ambient environment. For most packages, a better model is required.

## 4.3 Estimation with Junction-to-Board Thermal Resistance

A simple package thermal model which has demonstrated reasonable accuracy (about 20%) is a two-resistor model consisting of a junction-to-board and a junction-to-case thermal resistance. The junction-to-case thermal resistance covers the situation where a heat sink is used or where a substantial amount of heat is dissipated from the top of the package. The junction-to-board thermal resistance describes the thermal performance when most of the heat is conducted to the printed circuit board. It has been observed that the thermal performance of most plastic packages, especially PBGA packages, is strongly dependent on the board temperature.

If the board temperature is known, an estimate of the junction temperature in the environment can be made using the following equation:

$$T_J = T_B + (R_{\theta JB} \times P_D)$$

where:

$R_{\theta JB}$  = junction-to-board thermal resistance ( $^{\circ}\text{C}/\text{W}$ )

$T_B$  = board temperature ( $^{\circ}\text{C}$ )

$P_D$  = power dissipation in package

If the board temperature is known and the heat loss from the package case to the air can be ignored, acceptable predictions of junction temperature can be made. For this method to work, the board and board mounting must be similar to the test board used to determine the junction-to-board thermal resistance, namely a 2s2p (board with a power and a ground plane) and by attaching the thermal balls to the ground plane.

## 4.4 Estimation Using Simulation

When the board temperature is not known, a thermal simulation of the application is needed. The simple two-resistor model can be used with the thermal simulation of the application, or a more accurate and complex model of the package can be used in the thermal simulation.

## 4.5 Experimental Determination

To determine the junction temperature of the device in the application after prototypes are available, the thermal characterization parameter ( $\Psi_{JT}$ ) can be used to determine the junction temperature with a measurement of the temperature at the top center of the package case using the following equation:

$$T_J = T_T + (\Psi_{JT} \times P_D)$$

where:

$\Psi_{JT}$  = thermal characterization parameter

$T_T$  = thermocouple temperature on top of package

$P_D$  = power dissipation in package

The thermal characterization parameter is measured per JEDEC JESD51-2 specification using a 40-gauge type T thermocouple epoxied to the top center of the package case. The thermocouple should be positioned so that the thermocouple junction rests on the package. A small amount of epoxy is placed over the thermocouple junction and over 1 mm of wire extending from the junction. The thermocouple wire is placed flat against the case to avoid measurement errors caused by cooling effects of the thermocouple wire.

## 4.6 Layout Practices

Each VDD and VDDH pin should be provided with a low-impedance path to the board's power supplies. Each ground pin should likewise be provided with a low-impedance path to ground. The power supply pins drive distinct groups of logic on chip. The VDD and VDDH power supplies should be bypassed to ground using bypass capacitors located as close as possible to the four sides of the package. For filtering high frequency noise, a capacitor of 0.1uF on each VDD and VDDH pin is recommended. Further, for medium frequency noise, a total of 2 capacitors of 47uF for VDD and 2 capacitors of 47uF for VDDH are also recommended. The capacitor leads and associated printed circuit traces connecting to chip VDD, VDDH and ground should be kept to less than half an inch per capacitor lead. Boards should employ separate inner layers for power and GND planes.

All output pins on the SoC have fast rise and fall times. Printed circuit (PC) trace interconnection length should be minimized to minimize overdamped conditions and reflections caused by these fast output switching times. This recommendation particularly applies to the address and data buses. Maximum PC trace lengths of six inches are recommended. Capacitance calculations should consider all device loads as well as parasitic capacitances due to the PC traces. Attention to proper PCB layout and bypassing becomes especially critical in systems with higher capacitive loads because these loads create higher transient currents in the VDD and GND circuits. Pull up all unused inputs or signals that will be inputs during reset. Special care should be taken to minimize the noise levels on the PLL supply pins.

## 4.7 References

Semiconductor Equipment and Materials International(415) 964-5111  
 805 East Middlefield Rd.  
 Mountain View, CA 94043

MIL-SPEC and EIA/JESD (JEDEC) Specifications800-854-7179 or  
 (Available from Global Engineering Documents)303-397-7956

JEDEC Specifications <http://www.jedec.org>

1. C.E. Triplett and B. Joiner, “An Experimental Characterization of a 272 PBGA Within an Automotive Engine Controller Module,” Proceedings of SemiTherm, San Diego, 1998, pp. 47–54.
2. B. Joiner and V. Adams, “Measurement and Simulation of Junction to Board Thermal Resistance and Its Application in Thermal Modeling,” Proceedings of SemiTherm, San Diego, 1999, pp. 212–220.

## 5 Power Dissipation

This table provides preliminary, estimated power dissipation for various configurations. Note that suitable thermal management is required to ensure the junction temperature does not exceed the maximum specified value. Also note that the I/O power should be included when determining whether to use a heat sink. For a complete list of possible clock configurations, see [Section 7, “Clock Configuration Modes.”](#)

**Table 8. Estimated Power Dissipation for Various Configurations<sup>1</sup>**

Bus (MHz)	CPM Multiplication Factor	CPM (MHz)	CPU Multiplication Factor	CPU (MHz)	P <sub>INT</sub> (W) <sup>2,3</sup>	
					V <sub>ddl</sub> 1.5 Volts	
					Nominal	Maximum
66.67	3	200	4	266	1	1.2
100	2	200	3	300	1.1	1.3
100	2	200	4	400	1.3	1.5
133	2	267	3	400	1.5	1.8

<sup>1</sup> Test temperature = 105° C

<sup>2</sup> P<sub>INT</sub> = I<sub>DD</sub> × V<sub>DD</sub> Watts

<sup>3</sup> Values do not include I/O. Add the following estimates for active I/O based on the following bus speeds:

66.7 MHz = 0.35 W (nominal), 0.4 W (maximum)

83.3 MHz = 0.4 W (nominal), 0.5 W (maximum)

100 MHz = 0.5 W (nominal), 0.6 W (maximum)

133 MHz = 0.7 W (nominal), 0.8 W (maximum)

## 6 AC Electrical Characteristics

The following sections include illustrations and tables of clock diagrams, signals, and CPM outputs and inputs for 66.67/83.33/100/133 MHz devices. Note that AC timings are based on a 50-pf load for MAX Delay and 10-pf load for MIN delay. Typical output buffer impedances are shown in this table.

**Table 9. Output Buffer Impedances<sup>1</sup>**

Output Buffers	Typical Impedance ( $\Omega$ )
60x bus	45 or 27 <sup>2</sup>
Memory controller	45 or 27 <sup>2</sup>
Parallel I/O	45
PCI	27

<sup>1</sup> These are typical values at 65° C. Impedance may vary by  $\pm 25\%$  with process and temperature.

<sup>2</sup> Impedance value is selected through SIUMCR[20,21]. See the SoC reference manual.

### 6.1 CPM AC Characteristics

This table lists CPM output characteristics.

**Table 10. AC Characteristics for CPM Outputs<sup>1</sup>**

Spec Number		Characteristic	Value (ns)							
Max	Min		Maximum Delay				Minimum Delay			
			66 MHz	83 MHz	100 MHz	133 MHz	66 MHz	83 MHz	100 MHz	133 MHz
sp36a	sp37a	FCC outputs—internal clock (NMSI)	6	5.5	5.5	5.5	0.5	0.5	0.5	0.5
sp36b	sp37b	FCC outputs—external clock (NMSI)	8	8	8	8	2	2	2	2
sp38a	sp39a	SCC/SMC/SPI/I2C outputs—internal clock (NMSI)	10	10	10	10	0	0	0	0
sp38b	sp39b	SCC/SMC/SPI/I2C outputs—external clock (NMSI)	8	8	8	8	2	2	2	2
sp40	sp41	TDM outputs/SI	11	11	11	11	2.5	2.5	2.5	2.5
sp42	sp43	TIMER/IDMA outputs	11	11	11	11	0.5	0.5	0.5	0.5
sp42a	sp43a	PIO outputs	11	11	11	11	0.5	0.5	0.5	0.5

<sup>1</sup> Output specifications are measured from the 50% level of the rising edge of CLKIN to the 50% level of the signal. Timings are measured at the pin.

This table lists CPM input characteristics.

**NOTE: Rise/Fall Time on CPM Input Pins**

It is recommended that the rise/fall time on CPM input pins should not exceed 5 ns. This should be enforced especially on clock signals. Rise time refers to signal transitions from 10% to 90% of VCC; fall time refers to transitions from 90% to 10% of VCC.

**Table 11. AC Characteristics for CPM Inputs<sup>1</sup>**

Spec Number		Characteristic	Value (ns)							
Setup	Hold		Setup				Hold			
			66 MHz	83 MHz	100 MHz	133 MHz	66 MHz	83 MHz	100 MHz	133 MHz
sp16a	sp17a	FCC inputs—internal clock (NMSI)	6	6	6	6	0	0	0	0
sp16b	sp17b	FCC inputs—external clock (NMSI)	2.5	2.5	2.5	2.5	2	2	2	2
sp18a	sp19a	SCC/SMC/SPI/I2C inputs—internal clock (NMSI)	6	6	6	6	0	0	0	0
sp18b	sp19b	SCC/SMC/SPI/I2C inputs—external clock (NMSI)	4	4	4	4	2	2	2	2
sp20	sp21	TDM inputs/SI	3	3	3	3	2.5	2.5	2.5	2.5
sp22	sp23	PIO/TIMER/IDMA inputs	8	8	8	8	0.5	0.5	0.5	0.5

<sup>1</sup> Input specifications are measured from the 50% level of the signal to the 50% level of the rising edge of CLKIN. Timings are measured at the pin.

**NOTE**

Although the specifications generally reference the rising edge of the clock, the following AC timing diagrams also apply when the falling edge is the active edge.

This figure shows the FCC internal clock.

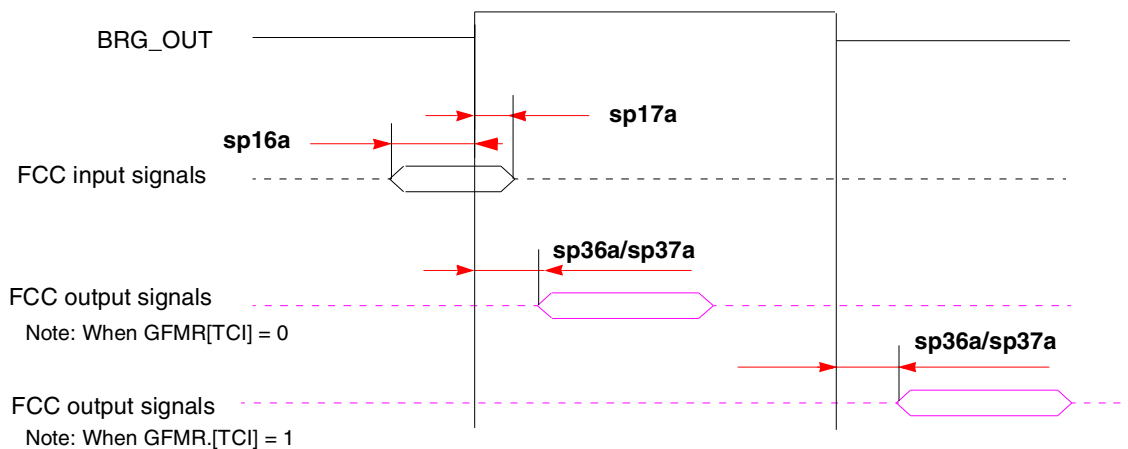

**Figure 3. FCC Internal Clock Diagram**

This figure shows the FCC external clock.

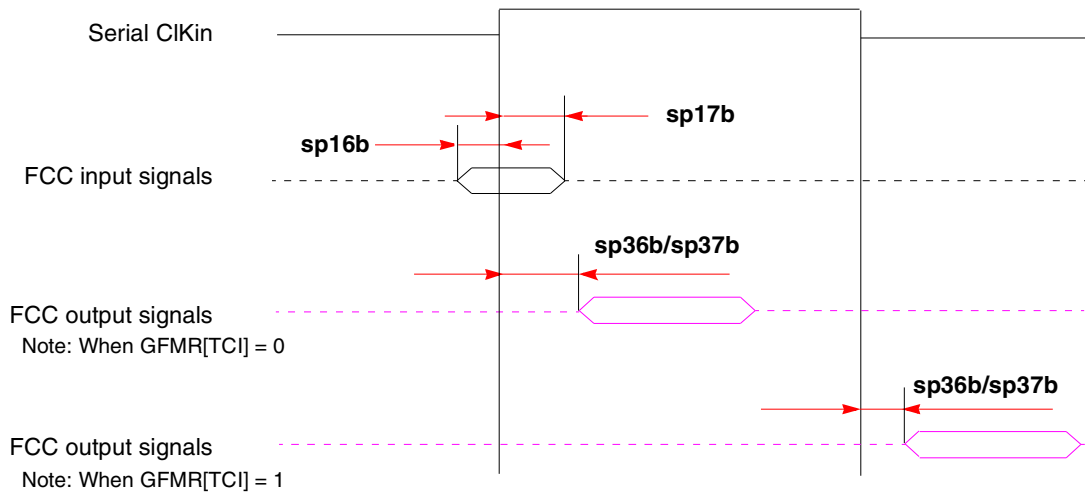
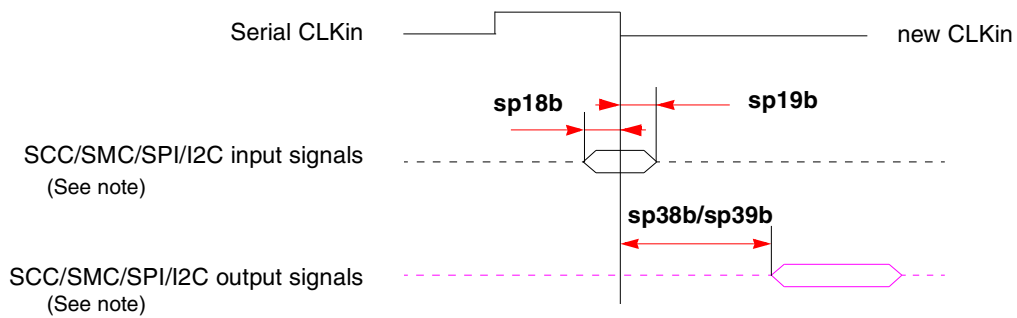

Figure 4. FCC External Clock Diagram

This figure shows the SCC/SMC/SPI/I<sup>2</sup>C external clock.



**Note:** There are four possible timing conditions for SPI:

1. Input sampled on the rising edge and output driven on the rising edge.
2. Input sampled on the rising edge and output driven on the falling edge.
3. Input sampled on the falling edge and output driven on the falling edge (shown).
4. Input sampled on the falling edge and output driven on the rising edge.

**Note:** There are two possible timing conditions for SCC/SMC/I<sup>2</sup>C:

1. Input sampled on the falling edge and output driven on the falling edge (shown).
2. Input sampled on the falling edge and output driven on the rising edge.

Figure 5. SCC/SMC/SPI/I<sup>2</sup>C External Clock Diagram

This figure shows the SCC/SMC/SPI/I<sup>2</sup>C internal clock.



- Note:** There are four possible timing conditions for SCC and SPI:
1. Input sampled on the rising edge and output driven on the rising edge (shown).
  2. Input sampled on the rising edge and output driven on the falling edge.
  3. Input sampled on the falling edge and output driven on the falling edge.
  4. Input sampled on the falling edge and output driven on the rising edge.

**Figure 6. SCC/SMC/SPI/I<sup>2</sup>C Internal Clock Diagram**

This figure shows TDM input and output signals.



- Note:** There are four possible TDM timing conditions:
1. Input sampled on the rising edge and output driven on the rising edge (shown).
  2. Input sampled on the rising edge and output driven on the falling edge.
  3. Input sampled on the falling edge and output driven on the falling edge.
  4. Input sampled on the falling edge and output driven on the rising edge.

**Figure 7. TDM Signal Diagram**

This figure shows PIO and timer signals.



**Note:** TGATE is asserted on the rising edge of the clock; it is deasserted on the falling edge.

**Figure 8. PIO and Timer Signal Diagram**

## 6.2 SIU AC Characteristics

This table lists SIU input characteristics.

### **NOTE: CLKIN Jitter and Duty Cycle**

The CLKIN input to the SoC should not exceed  $\pm 150$  psec of jitter (peak-to-peak). This represents total input jitter—the combination of short term (peak-to-peak) and long term (cumulative). The duty cycle of CLKIN should not exceed the ratio of 40:60.

### **NOTE: Spread Spectrum Clocking**

Spread spectrum clocking is allowed with 1% input frequency down-spread at maximum 60 KHz modulation rate regardless of input frequency.

### **NOTE: PCI AC Timing**

The SoC meets the timing requirements of *PCI Specification Revision 2.2*. See [Section 7, “Clock Configuration Modes,”](#) and “Note: Tval (Output Hold)” to determine if a specific clock configuration is compliant.

**NOTE: Conditions**

The following conditions must be met in order to operate the MPC8272 family devices with 133 MHz bus: single PowerQUICC II Bus mode must be used (no external master, BCR[EBM] = 0); data bus must be in Pipeline mode (BRx[DR] = 1); internal arbiter and memory controller must be used. For expected load of above 40 pF, it is recommended that data and address buses be configured to low (25 Ω) impedance (SIUMCR[HLBE0] = 1, SIUMCR[HLBE1] = 1).

**Table 12. AC Characteristics for SIU Inputs<sup>1</sup>**

Spec Number		Characteristic	Value (ns)							
Setup	Hold		Setup				Hold			
			66 MHz	83 MHz	100 MHz	133 MHz	66 MHz	83 MHz	100 MHz	133 MHz
sp11	sp10	$\overline{AACK}/\overline{TA}/\overline{TS}/\overline{DBG}/\overline{BG}/\overline{BR}/\overline{ARTRY}/\overline{TEA}$	6	5	3.5	N/A	0.5	0.5	0.5	N/A
sp12	sp10	Data bus in normal mode	5	4	3.5	N/A	0.5	0.5	0.5	N/A
sp13	sp10	Data bus in pipeline mode (without ECC and PARITY)	N/A	4	2.5	1.5	N/A	0.5	0.5	0.5
sp15	sp10	All other pins	5	4	3.5	N/A	0.5	0.5	0.5	N/A

<sup>1</sup> Input specifications are measured from the 50% level of the signal to the 50% level of the rising edge of CLKIN. Timings are measured at the pin.

This table lists SIU output characteristics.

**Table 13. AC Characteristics for SIU Outputs<sup>1</sup>**

Spec Number		Characteristic	Value (ns)							
Max	Min		Maximum Delay				Minimum Delay			
			66 MHz	83 MHz	100 MHz	133 MHz	66 MHz	83 MHz	100 MHz	133 MHz
sp31	sp30	$\overline{PSDVAL}/\overline{TEA}/\overline{TA}$	7	6	5.5	N/A	1	1	1	N/A
sp32	sp30	ADD/ADD_atr./BADDR/CI/GBL/WT	8	6.5	5.5	4.5 <sup>2</sup>	1	1	1	1 <sup>2</sup>
sp33	sp30	Data bus <sup>3</sup>	6.5	6.5	5.5	4.5	0.8	0.8	0.8	1
sp34	sp30	Memory controller signals/ALE	6	5.5	5.5	4.5	1	1	1	1
sp35	sp30	All other signals	6	5.5	5.5	N/A	1	1	1	N/A

<sup>1</sup> Output specifications are measured from the 50% level of the rising edge of CLKIN to the 50% level of the signal. Timings are measured at the pin.

<sup>2</sup> Value is for ADD only; other sp32/sp30 signals are not applicable.

<sup>3</sup> To achieve 1 ns of hold time at 66.67/83.33/100 MHz, a minimum loading of 20 pF is required.

**NOTE**

Activating data pipelining (setting BRx[DR] in the memory controller) improves the AC timing.

This figure shows the interaction of several bus signals.



**Figure 9. Bus Signals**

This figure shows signal behavior in MEMC mode.

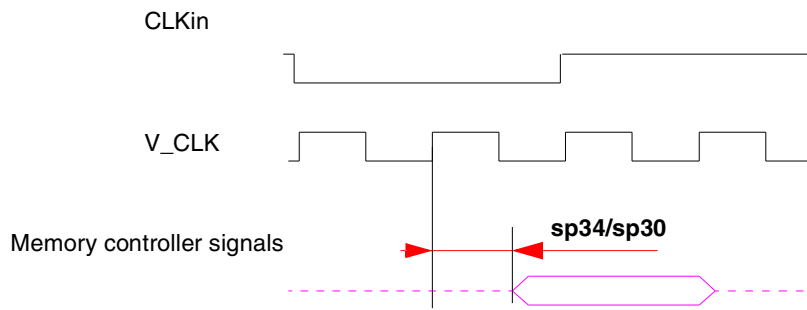

Figure 10. MEMC Mode Diagram

**NOTE**

Generally, all SoC bus and system output signals are driven from the rising edge of the input clock (CLKIn). Memory controller signals, however, trigger on four points within a CLKIn cycle. Each cycle is divided by four internal ticks: T1, T2, T3, and T4. T1 always occurs at the rising edge, and T3 at the falling edge, of CLKIn. However, the spacing of T2 and T4 depends on the PLL clock ratio selected, as shown in Table 14.

**Table 14. Tick Spacing for Memory Controller Signals**

PLL Clock Ratio	Tick Spacing (T1 Occurs at the Rising Edge of CLKIn)		
	T2	T3	T4
1:2, 1:3, 1:4, 1:5, 1:6	1/4 CLKIn	1/2 CLKIn	3/4 CLKIn
1:2.5	3/10 CLKIn	1/2 CLKIn	8/10 CLKIn
1:3.5	4/14 CLKIn	1/2 CLKIn	11/14 CLKIn

This table is a representation of the information in Table 14.



Figure 11. Internal Tick Spacing for Memory Controller Signals

**NOTE**

The UPM machine outputs change on the internal tick determined by the memory controller programming; the AC specifications are relative to the internal tick. Note that SDRAM and GPCM machine outputs change on CLKIn's rising edge.

### 6.3 JTAG Timings

This table lists the JTAG timings.

**Table 15. JTAG Timings<sup>1</sup>**

Parameter	Symbol <sup>2</sup>	Min	Max	Unit	Notes	
JTAG external clock frequency of operation	$f_{JTG}$	0	33.3	MHz	—	
JTAG external clock cycle time	$t_{JTG}$	30	—	ns	—	
JTAG external clock pulse width measured at 1.4V	$t_{JTKHKL}$	15	—	ns	—	
JTAG external clock rise and fall times	$t_{JTGR}$ and $t_{JTGF}$	0	5	ns	<sup>6</sup>	
TRST assert time	$t_{TRST}$	25	—	ns	<sup>3, 6</sup>	
Input setup times	Boundary-scan data	$t_{JTDVKH}$	4	—	ns	<sup>4, 7</sup>
	TMS, TDI	$t_{JTIVKH}$	4	—	ns	<sup>4, 7</sup>
Input hold times	Boundary-scan data	$t_{JTDXKH}$	10	—	ns	<sup>4, 7</sup>
	TMS, TDI	$t_{JTIXKH}$	10	—	ns	<sup>4, 7</sup>
Output valid times	Boundary-scan data	$t_{JTKLDV}$	—	10	ns	<sup>5, 7</sup>
	TDO	$t_{JTKLOV}$	—	10	ns	<sup>5, 7</sup>
Output hold times	Boundary-scan data	$t_{JTKLDX}$	1	—	ns	<sup>5, 7</sup>
	TDO	$t_{JTKLOX}$	1	—	ns	<sup>5, 7</sup>
JTAG external clock to output high impedance	Boundary-scan data	$t_{JTKLDZ}$	1	10	ns	<sup>5, 6</sup>
	TDO	$t_{JTKLOZ}$	1	10	ns	<sup>5, 6</sup>

<sup>1</sup> All outputs are measured from the midpoint voltage of the falling/rising edge of  $t_{TCLK}$  to the midpoint of the signal in question. The output timings are measured at the pins. All output timings assume a purely resistive 50-Ω load. Time-of-flight delays must be added for trace lengths, vias, and connectors in the system.

<sup>2</sup> The symbols used for timing specifications herein follow the pattern of  $t_{(first\ two\ letters\ of\ functional\ block)(signal)(state)\ (reference)(state)}$  for inputs and  $t_{(first\ two\ letters\ of\ functional\ block)(reference)(state)(signal)(state)}$  for outputs. For example,  $t_{JTDVKH}$  symbolizes JTAG device timing (JT) with respect to the time data input signals (D) reaching the valid state (V) relative to the  $t_{JTG}$  clock reference (K) going to the high (H) state or setup time. Also,  $t_{JTDXKH}$  symbolizes JTAG timing (JT) with respect to the time data input signals (D) went invalid (X) relative to the  $t_{JTG}$  clock reference (K) going to the high (H) state. Note that, in general, the clock reference symbol representation is based on three letters representing the clock of a particular functional. For rise and fall times, the latter convention is used with the appropriate letter: R (rise) or F (fall).

<sup>3</sup> TRST is an asynchronous level sensitive signal. The setup time is for test purposes only.

<sup>4</sup> Non-JTAG signal input timing with respect to  $t_{TCLK}$ .

<sup>5</sup> Non-JTAG signal output timing with respect to  $t_{TCLK}$ .

<sup>6</sup> Guaranteed by design.

<sup>7</sup> Guaranteed by design and device characterization.

## 7 Clock Configuration Modes

As shown in this table, the clocking mode is set according to two sources:

- PCI\_CFG[0]— An input signal. Also defined as “PCI\_HOST\_EN.” See Chapter 6, “External Signals,” and Chapter 9, “PCI Bridge,” in the SoC reference manual.
- PCI\_MODCK—Bit 27 in the Hard Reset Configuration Word. See Chapter 5, “Reset,” in the SoC reference manual.

**Table 16. SoC Clocking Modes**

Pins		Clocking Mode	PCI Clock Frequency Range (MHz)	Reference
PCI_CFG[0] <sup>1</sup>	PCI_MODCK <sup>2</sup>			
0	0	PCI host	50–66	<a href="#">Table 17</a>
0	1		25–50	<a href="#">Table 18</a>
1	0	PCI agent	50–66	<a href="#">Table 19</a>
1	1		25–50	<a href="#">Table 20</a>

<sup>1</sup> PCI\_HOST\_EN

<sup>2</sup> Determines PCI clock frequency range.

Within each mode, the configuration of bus, core, PCI, and CPM frequencies is determined by seven bits during the power-on reset—three hardware configuration pins (MODCK[1–3]) and four bits from hardware configuration word[28–31] (MODCK\_H). Both the PLLs and the dividers are set according to the selected clock operation mode as described in the following sections.

### NOTE

Clock configurations change only after  $\overline{\text{PORESET}}$  is asserted.

### NOTE: Tval (Output Hold)

The minimum Tval = 2 ns when PCI\_MODCK = 1, and the minimum Tval = 1 ns when PCI\_MODCK = 0. Therefore, designers should use clock configurations that fit this condition to achieve PCI-compliant AC timing.

### 7.1 PCI Host Mode

These tables show configurations for PCI host mode. The frequency values listed are for the purpose of illustration only. Users must select a mode and input bus frequency so that the resulting configuration does not exceed the frequency rating of the user’s device. Note that in PCI host mode the input clock is the bus clock.

**Table 17. Clock Configurations for PCI Host Mode (PCI\_MODCK=0)<sup>1,2</sup>**

Mode <sup>3</sup>	Bus Clock (MHz)		CPM Multiplication Factor <sup>4</sup>	CPM Clock (MHz)		CPU Multiplication Factor <sup>5</sup>	CPU Clock (MHz)		PCI Division Factor <sup>6</sup>	PCI Clock (MHz)	
	MODCK_H-MODCK[1-3]	Low		High	Low		High	Low		High	Low
<b>Default Modes (MODCK_H=0000)</b>											
0000_000	60.0	66.7	2	120.0	133.3	2.5	150.0	166.7	2	60.0	66.7
0000_001	50.0	66.7	2	100.0	133.3	3	150.0	200.0	2	50.0	66.7
0000_010	60.0	80.0	2.5	150.0	200.0	3	180.0	240.0	3	50.0	66.7
0000_011	60.0	80.0	2.5	150.0	200.0	3.5	210.0	280.0	3	50.0	66.7
0000_100	60.0	80.0	2.5	150.0	200.0	4	240.0	320.0	3	50.0	66.7
0000_101	50.0	66.7	3	150.0	200.0	3	150.0	200.0	3	50.0	66.7
0000_110	50.0	66.7	3.5	150.0	200.0	3.5	175.0	233.3	3	50.0	66.7
0000_111	50.0	66.7	3	150.0	200.0	4	200.0	266.6	3	50.0	66.7
<b>Full Configuration Modes</b>											
0001_000	50.0	66.7	3	150.0	200.0	5	250.0	333.3	3	50.0	66.7
0001_001	50.0	66.7	3	150.0	200.0	6	300.0	400.0	3	50.0	66.7
0001_010	50.0	66.7	3	150.0	200.0	7	350.0	466.6	3	50.0	66.7
0001_011	50.0	66.7	3	150.0	200.0	8	400.0	533.3	3	50.0	66.7
<b>Reserved</b>											
0010_000	50.0	66.7	4	200.0	266.6	5	250.0	333.3	4	50.0	66.7
0010_001	50.0	66.7	4	200.0	266.6	6	300.0	400.0	4	50.0	66.7
0010_010	50.0	66.7	4	200.0	266.6	7	350.0	466.6	4	50.0	66.7
0010_011	50.0	66.7	4	200.0	266.6	8	400.0	533.3	4	50.0	66.7
<b>Reserved</b>											
0010_100	75.0	100.0	4	300.0	400.0	5	375.0	500.0	6	50.0	66.7
0010_101	75.0	100.0	4	300.0	400.0	5.5	412.5	549.9	6	50.0	66.7
0010_110	75.0	100.0	4	300.0	400.0	6	450.0	599.9	6	50.0	66.7
<b>Reserved</b>											
0011_000	50.0	66.7	5	250.0	333.3	5	250.0	333.3	5	50.0	66.7
0011_001	50.0	66.7	5	250.0	333.3	6	300.0	400.0	5	50.0	66.7
0011_010	50.0	66.7	5	250.0	333.3	7	350.0	466.6	5	50.0	66.7
0011_011	50.0	66.7	5	250.0	333.3	8	400.0	533.3	5	50.0	66.7
<b>Reserved</b>											
0100_000	Reserved										

Table 17. Clock Configurations for PCI Host Mode (PCI\_MODCK=0)<sup>1,2</sup> (continued)

Mode <sup>3</sup>	Bus Clock (MHz)		CPM Multiplication Factor <sup>4</sup>	CPM Clock (MHz)		CPU Multiplication Factor <sup>5</sup>	CPU Clock (MHz)		PCI Division Factor <sup>6</sup>	PCI Clock (MHz)	
	MODCK_H-MODCK[1-3]	Low		High	Low		High	Low		High	Low
0100_001	50.0	66.7	6	300.0	400.0	6	300.0	400.0	6	50.0	66.7
0100_010	50.0	66.7	6	300.0	400.0	7	350.0	466.6	6	50.0	66.7
0100_011	50.0	66.7	6	300.0	400.0	8	400.0	533.3	6	50.0	66.7
0101_000	60.0	66.7	2	120.0	133.3	2.5	150.0	166.7	2	60.0	66.7
0101_001	50.0	66.7	2	100.0	133.3	3	150.0	200.0	2	50.0	66.7
0101_010	50.0	66.7	2	100.0	133.3	3.5	175.0	233.3	2	50.0	66.7
0101_011	50.0	66.7	2	100.0	133.3	4	200.0	266.6	2	50.0	66.7
0101_100	50.0	66.7	2	100.0	133.3	4.5	225.0	300.0	2	50.0	66.7
0101_101	83.3	111.1	3	250.0	333.3	3.5	291.7	388.9	5	50.0	66.7
0101_110	83.3	111.1	3	250.0	333.3	4	333.3	444.4	5	50.0	66.7
0101_111	83.3	111.1	3	250.0	333.3	4.5	375.0	500.0	5	50.0	66.7
0110_000	60.0	80.0	2.5	150.0	200.0	2.5	150.0	200.0	3	50.0	66.7
0110_001	60.0	80.0	2.5	150.0	200.0	3	180.0	240.0	3	50.0	66.7
0110_010	60.0	80.0	2.5	150.0	200.0	3.5	210.0	280.0	3	50.0	66.7
0110_011	60.0	80.0	2.5	150.0	200.0	4	240.0	320.0	3	50.0	66.7
0110_100	60.0	80.0	2.5	150.0	200.0	4.5	270.0	360.0	3	50.0	66.7
0110_101	60.0	80.0	2.5	150.0	200.0	5	300.0	400.0	3	50.0	66.7
0110_110	60.0	80.0	2.5	150.0	200.0	6	360.0	480.0	3	50.0	66.7
0111_000	Reserved										
0111_001	50.0	66.7	3	150.0	200.0	3	150.0	200.0	3	50.0	66.7
0111_010	50.0	66.7	3	150.0	200.0	3.5	175.0	233.3	3	50.0	66.7
0111_011	50.0	66.7	3	150.0	200.0	4	200.0	266.6	3	50.0	66.7
0111_100	50.0	66.7	3	150.0	200.0	4.5	225.0	300.0	3	50.0	66.7
1000_000	Reserved										
1000_001	66.7	88.9	3	200.0	266.6	3	200.0	266.6	4	50.0	66.7

**Table 17. Clock Configurations for PCI Host Mode (PCI\_MODCK=0)<sup>1,2</sup> (continued)**

Mode <sup>3</sup>	Bus Clock (MHz)		CPM Multiplication Factor <sup>4</sup>	CPM Clock (MHz)		CPU Multiplication Factor <sup>5</sup>	CPU Clock (MHz)		PCI Division Factor <sup>6</sup>	PCI Clock (MHz)	
	Low	High		Low	High		Low	High		Low	High
1000_010	66.7	88.9	3	200.0	266.6	3.5	233.3	311.1	4	50.0	66.7
1000_011	66.7	88.9	3	200.0	266.6	4	266.7	355.5	4	50.0	66.7
1000_100	66.7	88.9	3	200.0	266.6	4.5	300.0	400.0	4	50.0	66.7
1000_101	66.7	88.9	3	200.0	266.6	6	400.0	533.3	4	50.0	66.7
1000_110	66.7	88.9	3	200.0	266.6	6.5	433.3	577.7	4	50.0	66.7
1001_000	Reserved										
1001_001	Reserved										
1001_010	57.1	76.2	3.5	200.0	266.6	3.5	200.0	266.6	4	50.0	66.7
1001_011	57.1	76.2	3.5	200.0	266.6	4	228.6	304.7	4	50.0	66.7
1001_100	57.1	76.2	3.5	200.0	266.6	4.5	257.1	342.8	4	50.0	66.7
1001_101	85.7	114.3	3.5	300.0	400.0	5	428.6	571.4	6	50.0	66.7
1001_110	85.7	114.3	3.5	300.0	400.0	5.5	471.4	628.5	6	50.0	66.7
1001_111	85.7	114.3	3.5	300.0	400.0	6	514.3	685.6	6	50.0	66.7
1010_000	75.0	100.0	2	150.0	200.0	2	150.0	200.0	3	50.0	66.7
1010_001	75.0	100.0	2	150.0	200.0	2.5	187.5	250.0	3	50.0	66.7
1010_010	75.0	100.0	2	150.0	200.0	3	225.0	300.0	3	50.0	66.7
1010_011	75.0	100.0	2	150.0	200.0	3.5	262.5	350.0	3	50.0	66.7
1010_100	75.0	100.0	2	150.0	200.0	4	300.0	400.0	3	50.0	66.7
1010_101	100.0	133.3	2	200.0	266.6	2.5	250.0	333.3	4	50.0	66.7
1010_110	100.0	133.3	2	200.0	266.6	3	300.0	400.0	4	50.0	66.7
1010_111	100.0	133.3	2	200.0	266.6	3.5	350.0	466.6	4	50.0	66.7
1011_000	Reserved										
1011_001	80.0	106.7	2.5	200.0	266.6	2.5	200.0	266.6	4	50.0	66.7
1011_010	80.0	106.7	2.5	200.0	266.6	3	240.0	320.0	4	50.0	66.7
1011_011	80.0	106.7	2.5	200.0	266.6	3.5	280.0	373.3	4	50.0	66.7

**Table 17. Clock Configurations for PCI Host Mode (PCI\_MODCK=0)<sup>1,2</sup> (continued)**

Mode <sup>3</sup>	Bus Clock (MHz)		CPM Multiplication Factor <sup>4</sup>	CPM Clock (MHz)		CPU Multiplication Factor <sup>5</sup>	CPU Clock (MHz)		PCI Division Factor <sup>6</sup>	PCI Clock (MHz)	
	Low	High		Low	High		Low	High		Low	High
1011_100	80.0	106.7	2.5	200.0	266.6	4	320.0	426.6	4	50.0	66.7
1011_101	80.0	106.7	2.5	200.0	266.6	4.5	360.0	480.0	4	50.0	66.7
1101_000	100.0	133.3	2.5	250.0	333.3	3	300.0	400.0	5	50.0	66.7
1101_001	100.0	133.3	2.5	250.0	333.3	3.5	350.0	466.6	5	50.0	66.7
1101_010	100.0	133.3	2.5	250.0	333.3	4	400.0	533.3	5	50.0	66.7
1101_011	100.0	133.3	2.5	250.0	333.3	4.5	450.0	599.9	5	50.0	66.7
1101_100	100.0	133.3	2.5	250.0	333.3	5	500.0	666.6	5	50.0	66.7
1101_101	125.0	166.7	2	250.0	333.3	3	375.0	500.0	5	50.0	66.7
1101_110	125.0	166.7	2	250.0	333.3	4	500.0	666.6	5	50.0	66.7
1110_000	100.0	133.3	3	300.0	400.0	3.5	350.0	466.6	6	50.0	66.7
1110_001	100.0	133.3	3	300.0	400.0	4	400.0	533.3	6	50.0	66.7
1110_010	100.0	133.3	3	300.0	400.0	4.5	450.0	599.9	6	50.0	66.7
1110_011	100.0	133.3	3	300.0	400.0	5	500.0	666.6	6	50.0	66.7
1110_100	100.0	133.3	3	300.0	400.0	5.5	550.0	733.3	6	50.0	66.7
1100_000	Reserved										
1100_001	Reserved										
1100_010	Reserved										

<sup>1</sup> The “low” values are the minimum allowable frequencies for a given clock mode. The minimum bus frequency in a table entry guarantees only the required minimum CPU operating frequency. The “high” values are for the purpose of illustration only. Users must select a mode and input bus frequency so that the resulting configuration does not exceed the frequency rating of the user’s device. The minimum CPU frequency is 150 MHz for commercial temperature devices and 175 MHz for extended temperature devices. The minimum CPM frequency is 120 MHz.

<sup>2</sup> PCI\_MODCK determines the PCI clock frequency range. See [Table 18](#) for lower range configurations.

<sup>3</sup> MODCK\_H = hard reset configuration word [28–31] (see Section 5.4 in the SoC reference manual). MODCK[1-3] = three hardware configuration pins.

<sup>4</sup> CPM multiplication factor = CPM clock/bus clock

<sup>5</sup> CPU multiplication factor = Core PLL multiplication factor

<sup>6</sup> CPM\_CLK/PCI\_CLK ratio. When PCI\_MODCK = 0, the ratio of CPM\_CLK/PCI\_CLK should be calculated from SCCR[PCIDF] as follows:

$$\text{CPM\_CLK/PCI\_CLK} = (\text{PCIDF} + 1) / 2.$$

**Table 18. Clock Configurations for PCI Host Mode (PCI\_MODCK=1)<sup>1,2</sup>**

Mode <sup>3</sup>	Bus Clock (MHz)		CPM Multiplication Factor <sup>4</sup>	CPM Clock (MHz)		CPU Multiplication Factor <sup>5</sup>	CPU Clock (MHz)		PCI Division Factor <sup>6</sup>	PCI Clock (MHz)	
	Low	High		Low	High		Low	High		Low	High
Default Modes (MODCK_H=0000)											
0000_000	60.0	100.0	2	120.0	200.0	2.5	150.0	250.0	4	30.0	50.0
0000_001	50.0	100.0	2	100.0	200.0	3	150.0	300.0	4	25.0	50.0
0000_010	60.0	120.0	2.5	150.0	300.0	3	180.0	360.0	6	25.0	50.0
0000_011	60.0	120.0	2.5	150.0	300.0	3.5	210.0	420.0	6	25.0	50.0
0000_100	60.0	120.0	2.5	150.0	300.0	4	240.0	480.0	6	25.0	50.0
0000_101	50.0	100.0	3	150.0	300.0	3	150.0	300.0	6	25.0	50.0
0000_110	50.0	100.0	3	150.0	300.0	3.5	175.0	350.0	6	25.0	50.0
0000_111	50.0	100.0	3	150.0	300.0	4	200.0	400.0	6	25.0	50.0
Full Configuration Modes											
0001_000	50.0	100.0	3	150.0	300.0	5	250.0	500.0	6	25.0	50.0
0001_001	50.0	100.0	3	150.0	300.0	6	300.0	600.0	6	25.0	50.0
0001_010	50.0	100.0	3	150.0	300.0	7	350.0	700.0	6	25.0	50.0
0001_011	50.0	100.0	3	150.0	300.0	8	400.0	800.0	6	25.0	50.0
0010_000	50.0	100.0	4	200.0	400.0	5	250.0	500.0	8	25.0	50.0
0010_001	50.0	100.0	4	200.0	400.0	6	300.0	600.0	8	25.0	50.0
0010_010	50.0	100.0	4	200.0	400.0	7	350.0	700.0	8	25.0	50.0
0010_011	50.0	100.0	4	200.0	400.0	8	400.0	800.0	8	25.0	50.0
0010_100	37.5	75.0	4	150.0	300.0	5	187.5	375.0	6	25.0	50.0
0010_101	37.5	75.0	4	150.0	300.0	5.5	206.3	412.5	6	25.0	50.0
0010_110	37.5	75.0	4	150.0	300.0	6	225.0	450.0	6	25.0	50.0
0011_000	30.0	50.0	5	150.0	250.0	5	150.0	250.0	5	30.0	50.0
0011_001	25.0	50.0	5	125.0	250.0	6	150.0	300.0	5	25.0	50.0
0011_010	25.0	50.0	5	125.0	250.0	7	175.0	350.0	5	25.0	50.0
0011_011	25.0	50.0	5	125.0	250.0	8	200.0	400.0	5	25.0	50.0
0100_000	Reserved										

Table 18. Clock Configurations for PCI Host Mode (PCI\_MODCK=1)<sup>1,2</sup> (continued)

Mode <sup>3</sup>	Bus Clock (MHz)		CPM Multiplication Factor <sup>4</sup>	CPM Clock (MHz)		CPU Multiplication Factor <sup>5</sup>	CPU Clock (MHz)		PCI Division Factor <sup>6</sup>	PCI Clock (MHz)	
	MODCK_H-MODCK[1-3]	Low		High	Low		High	Low		High	Low
0100_001	25.0	50.0	6	150.0	300.0	6	150.0	300.0	6	25.0	50.0
0100_010	25.0	50.0	6	150.0	300.0	7	175.0	350.0	6	25.0	50.0
0100_011	25.0	50.0	6	150.0	300.0	8	200.0	400.0	6	25.0	50.0
0101_000	60.0	100.0	2	120.0	200.0	2.5	150.0	250.0	4	30.0	50.0
0101_001	50.0	100.0	2	100.0	200.0	3	150.0	300.0	4	25.0	50.0
0101_010	50.0	100.0	2	100.0	200.0	3.5	175.0	350.0	4	25.0	50.0
0101_011	50.0	100.0	2	100.0	200.0	4	200.0	400.0	4	25.0	50.0
0101_100	50.0	100.0	2	100.0	200.0	4.5	225.0	450.0	4	25.0	50.0
0101_101	42.9	83.3	3	128.6	250.0	3.5	150.0	291.7	5	25.7	50.0
0101_110	41.7	83.3	3	125.0	250.0	4	166.7	333.3	5	25.0	50.0
0101_111	41.7	83.3	3	125.0	250.0	4.5	187.5	375.0	5	25.0	50.0
0110_000	60.0	120.0	2.5	150.0	300.0	2.5	150.0	300.0	6	25.0	50.0
0110_001	60.0	120.0	2.5	150.0	300.0	3	180.0	360.0	6	25.0	50.0
0110_010	60.0	120.0	2.5	150.0	300.0	3.5	210.0	420.0	6	25.0	50.0
0110_011	60.0	120.0	2.5	150.0	300.0	4	240.0	480.0	6	25.0	50.0
0110_100	60.0	120.0	2.5	150.0	300.0	4.5	270.0	540.0	6	25.0	50.0
0110_101	60.0	120.0	2.5	150.0	300.0	5	300.0	600.0	6	25.0	50.0
0110_110	60.0	120.0	2.5	150.0	300.0	6	360.0	720.0	6	25.0	50.0
0111_000	Reserved										
0111_001	50.0	100.0	3	150.0	300.0	3	150.0	300.0	6	25.0	50.0
0111_010	50.0	100.0	3	150.0	300.0	3.5	175.0	350.0	6	25.0	50.0
0111_011	50.0	100.0	3	150.0	300.0	4	200.0	400.0	6	25.0	50.0
0111_100	50.0	100.0	3	150.0	300.0	4.5	225.0	450.0	6	25.0	50.0
1000_000	Reserved										
1000_001	66.7	133.3	3	200.0	400.0	3	200.0	400.0	8	25.0	50.0

**Table 18. Clock Configurations for PCI Host Mode (PCI\_MODCK=1)<sup>1,2</sup> (continued)**

Mode <sup>3</sup>	Bus Clock (MHz)		CPM Multiplication Factor <sup>4</sup>	CPM Clock (MHz)		CPU Multiplication Factor <sup>5</sup>	CPU Clock (MHz)		PCI Division Factor <sup>6</sup>	PCI Clock (MHz)	
	MODCK_H-MODCK[1-3]	Low		High	Low		High	Low		High	Low
1000_010	66.7	133.3	3	200.0	400.0	3.5	233.3	466.7	8	25.0	50.0
1000_011	66.7	133.3	3	200.0	400.0	4	266.7	533.3	8	25.0	50.0
1000_100	66.7	133.3	3	200.0	400.0	4.5	300.0	600.0	8	25.0	50.0
1000_101	66.7	133.3	3	200.0	400.0	6	400.0	800.0	8	25.0	50.0
1000_110	66.7	133.3	3	200.0	400.0	6.5	433.3	866.7	8	25.0	50.0
1001_000	Reserved										
1001_001	Reserved										
1001_010	57.1	114.3	3.5	200.0	400.0	3.5	200.0	400.0	8	25.0	50.0
1001_011	57.1	114.3	3.5	200.0	400.0	4	228.6	457.1	8	25.0	50.0
1001_100	57.1	114.3	3.5	200.0	400.0	4.5	257.1	514.3	8	25.0	50.0
1001_101	42.9	85.7	3.5	150.0	300.0	5	214.3	428.6	6	25.0	50.0
1001_110	42.9	85.7	3.5	150.0	300.0	5.5	235.7	471.4	6	25.0	50.0
1001_111	42.9	85.7	3.5	150.0	300.0	6	257.1	514.3	6	25.0	50.0
1010_000	75.0	150.0	2	150.0	300.0	2	150.0	300.0	6	25.0	50.0
1010_001	75.0	150.0	2	150.0	300.0	2.5	187.5	375.0	6	25.0	50.0
1010_010	75.0	150.0	2	150.0	300.0	3	225.0	450.0	6	25.0	50.0
1010_011	75.0	150.0	2	150.0	300.0	3.5	262.5	525.0	6	25.0	50.0
1010_100	75.0	150.0	2	150.0	300.0	4	300.0	600.0	6	25.0	50.0
1010_101	100.0	200.0	2	200.0	400.0	2.5	250.0	500.0	8	25.0	50.0
1010_110	100.0	200.0	2	200.0	400.0	3	300.0	600.0	8	25.0	50.0
1010_111	100.0	200.0	2	200.0	400.0	3.5	350.0	700.0	8	25.0	50.0
1011_000	Reserved										
1011_001	80.0	160.0	2.5	200.0	400.0	2.5	200.0	400.0	8	25.0	50.0
1011_010	80.0	160.0	2.5	200.0	400.0	3	240.0	480.0	8	25.0	50.0
1011_011	80.0	160.0	2.5	200.0	400.0	3.5	280.0	560.0	8	25.0	50.0
1011_100	80.0	160.0	2.5	200.0	400.0	4	320.0	640.0	8	25.0	50.0

**Table 18. Clock Configurations for PCI Host Mode (PCI\_MODCK=1)<sup>1,2</sup> (continued)**

Mode <sup>3</sup>	Bus Clock (MHz)		CPM Multiplication Factor <sup>4</sup>	CPM Clock (MHz)		CPU Multiplication Factor <sup>5</sup>	CPU Clock (MHz)		PCI Division Factor <sup>6</sup>	PCI Clock (MHz)	
	Low	High		Low	High		Low	High		Low	High
1011_101	80.0	160.0	2.5	200.0	400.0	4.5	360.0	720.0	8	25.0	50.0
1101_000	50.0	100.0	2.5	125.0	250.0	3	150.0	300.0	5	25.0	50.0
1101_001	50.0	100.0	2.5	125.0	250.0	3.5	175.0	350.0	5	25.0	50.0
1101_010	50.0	100.0	2.5	125.0	250.0	4	200.0	400.0	5	25.0	50.0
1101_011	50.0	100.0	2.5	125.0	250.0	4.5	225.0	450.0	5	25.0	50.0
1101_100	50.0	100.0	2.5	125.0	250.0	5	250.0	500.0	5	25.0	50.0
1101_101	62.5	125.0	2	125.0	250.0	3	187.5	375.0	5	25.0	50.0
1101_110	62.5	125.0	2	125.0	250.0	4	250.0	500.0	5	25.0	50.0
1110_000	50.0	100.0	3	150.0	300.0	3.5	175.0	350.0	6	25.0	50.0
1110_001	50.0	100.0	3	150.0	300.0	4	200.0	400.0	6	25.0	50.0
1110_010	50.0	100.0	3	150.0	300.0	4.5	225.0	450.0	6	25.0	50.0
1110_011	50.0	100.0	3	150.0	300.0	5	250.0	500.0	6	25.0	50.0
1110_100	50.0	100.0	3	150.0	300.0	5.5	275.0	550.0	6	25.0	50.0
1100_000	Reserved										
1100_001	Reserved										
1100_010	Reserved										

<sup>1</sup> The “low” values are the minimum allowable frequencies for a given clock mode. The minimum bus frequency in a table entry guarantees only the required minimum CPU operating frequency. The “high” values are for the purpose of illustration only. Users must select a mode and input bus frequency so that the resulting configuration does not exceed the frequency rating of the user’s device. The minimum CPU frequency is 150 MHz for commercial temperature devices and 175 MHz for extended temperature devices. The minimum CPM frequency is 120 MHz.

<sup>2</sup> PCI\_MODCK determines the PCI clock frequency range. See [Table 17](#) for higher range configurations.

<sup>3</sup> MODCK\_H = hard reset configuration word [28–31] (see Section 5.4 in the SoC reference manual). MODCK[1-3] = three hardware configuration pins.

<sup>4</sup> CPM multiplication factor = CPM clock/bus clock

<sup>5</sup> CPU multiplication factor = Core PLL multiplication factor

- <sup>6</sup> CPM\_CLK/PCI\_CLK ratio. When PCI\_MODCK = 1, the ratio of CPM\_CLK/PCI\_CLK should be calculated from PCIDF as follows:  
 PCIDF = 3 > CPM\_CLK/PCI\_CLK = 4  
 PCIDF = 5 > CPM\_CLK/PCI\_CLK = 6  
 PCIDF = 7 > CPM\_CLK/PCI\_CLK = 8  
 PCIDF = 9 > CPM\_CLK/PCI\_CLK = 5  
 PCIDF = B > CPM\_CLK/PCI\_CLK = 6

## 7.2 PCI Agent Mode

These tables show configurations for PCI agent mode. The frequency values listed are for the purpose of illustration only. Users must select a mode and input bus frequency so that the resulting configuration does not exceed the frequency rating of the user’s device. Note that in PCI agent mode the input clock is PCI clock.

**Table 19. Clock Configurations for PCI Agent Mode (PCI\_MODCK=0)<sup>1,2</sup>**

Mode <sup>3</sup>	PCI Clock (MHz)		CPM Multiplication Factor <sup>4</sup>	CPM Clock (MHz)		CPU Multiplication Factor <sup>5</sup>	CPU Clock (MHz)		Bus Division Factor	Bus Clock (MHz)	
	Low	High		Low	High		Low	High		Low	High
<b>Default Modes (MODCK_H=0000)</b>											
0000_000	60.0	66.7	2	120.0	133.3	2.5	150.0	166.7	2	60.0	66.7
0000_001	50.0	66.7	2	100.0	133.3	3	150.0	200.0	2	50.0	66.7
0000_010	50.0	66.7	3	150.0	200.0	3	150.0	200.0	3	50.0	66.7
0000_011	50.0	66.7	3	150.0	200.0	4	200.0	266.6	3	50.0	66.7
0000_100	50.0	66.7	3	150.0	200.0	3	180.0	240.0	2.5	60.0	80.0
0000_101	50.0	66.7	3	150.0	200.0	3.5	210.0	280.0	2.5	60.0	80.0
0000_110	50.0	66.7	4	200.0	266.6	3.5	233.3	311.1	3	66.7	88.9
0000_111	50.0	66.7	4	200.0	266.6	3	240.0	320.0	2.5	80.0	106.7
<b>Full Configuration Modes</b>											
0001_001	60.0	66.7	2	120.0	133.3	5	150.0	166.7	4	30.0	33.3
0001_010	50.0	66.7	2	100.0	133.3	6	150.0	200.0	4	25.0	33.3
0001_011	50.0	66.7	2	100.0	133.3	7	175.0	233.3	4	25.0	33.3
0001_100	50.0	66.7	2	100.0	133.3	8	200.0	266.6	4	25.0	33.3
0010_001	50.0	66.7	3	150.0	200.0	3	180.0	240.0	2.5	60.0	80.0
0010_010	50.0	66.7	3	150.0	200.0	3.5	210.0	280.0	2.5	60.0	80.0
0010_011	50.0	66.7	3	150.0	200.0	4	240.0	320.0	2.5	60.0	80.0
0010_100	50.0	66.7	3	150.0	200.0	4.5	270.0	360.0	2.5	60.0	80.0

Table 19. Clock Configurations for PCI Agent Mode (PCI\_MODCK=0)<sup>1,2</sup> (continued)

Mode <sup>3</sup>	PCI Clock (MHz)		CPM Multiplication Factor <sup>4</sup>	CPM Clock (MHz)		CPU Multiplication Factor <sup>5</sup>	CPU Clock (MHz)		Bus Division Factor	Bus Clock (MHz)	
	Low	High		Low	High		Low	High		Low	High
0011_000	Reserved										
0011_001	Reserved										
0011_010	Reserved										
0011_011	Reserved										
0011_100	Reserved										
0100_000	Reserved										
0100_001	50.0	66.7	3	150.0	200.0	3	150.0	200.0	3	50.0	66.7
0100_010	50.0	66.7	3	150.0	200.0	3.5	175.0	200.0	3	50.0	66.7
0100_011	50.0	66.7	3	150.0	200.0	4	200.0	266.6	3	50.0	66.7
0100_100	50.0	66.7	3	150.0	200.0	4.5	225.0	300.0	3	50.0	66.7
0101_000	50.0	66.7	5	250.0	333.3	2.5	250.0	333.3	2.5	100.0	133.3
0101_001	50.0	66.7	5	250.0	333.3	3	300.0	400.0	2.5	100.0	133.3
0101_010	50.0	66.7	5	250.0	333.3	3.5	350.0	466.6	2.5	100.0	133.3
0101_011	50.0	66.7	5	250.0	333.3	4	400.0	533.3	2.5	100.0	133.3
0101_100	50.0	66.7	5	250.0	333.3	4.5	450.0	599.9	2.5	100.0	133.3
0101_101	50.0	66.7	5	250.0	333.3	5	500.0	666.6	2.5	100.0	133.3
0101_110	50.0	66.7	5	250.0	333.3	5.5	550.0	733.3	2.5	100.0	133.3
0110_000	Reserved										
0110_001	50.0	66.7	4	200.0	266.6	3	200.0	266.6	3	66.7	88.9
0110_010	50.0	66.7	4	200.0	266.6	3.5	233.3	311.1	3	66.7	88.9
0110_011	50.0	66.7	4	200.0	266.6	4	266.7	355.5	3	66.7	88.9
0110_100	50.0	66.7	4	200.0	266.6	4.5	300.0	400.0	3	66.7	88.9
0111_000	50.0	66.7	3	150.0	200.0	2	150.0	200.0	2	75.0	100.0
0111_001	50.0	66.7	3	150.0	200.0	2.5	187.5	250.0	2	75.0	100.0
0111_010	50.0	66.7	3	150.0	200.0	3	225.0	300.0	2	75.0	100.0
0111_011	50.0	66.7	3	150.0	200.0	3.5	262.5	350.0	2	75.0	100.0

**Table 19. Clock Configurations for PCI Agent Mode (PCI\_MODCK=0)<sup>1,2</sup> (continued)**

Mode <sup>3</sup>	PCI Clock (MHz)		CPM Multiplication Factor <sup>4</sup>	CPM Clock (MHz)		CPU Multiplication Factor <sup>5</sup>	CPU Clock (MHz)		Bus Division Factor	Bus Clock (MHz)	
	MODCK_H-MODCK[1-3]	Low		High	Low		High	Low		High	Low
1000_000	Reserved										
1000_001	50.0	66.7	3	150.0	200.0	2.5	150.0	166.7	2.5	60.0	80.0
1000_010	50.0	66.7	3	150.0	200.0	3	180.0	240.0	2.5	60.0	80.0
1000_011	50.0	66.7	3	150.0	200.0	3.5	210.0	280.0	2.5	60.0	80.0
1000_100	50.0	66.7	3	150.0	200.0	4	240.0	320.0	2.5	60.0	80.0
1000_101	50.0	66.7	3	150.0	200.0	4.5	270.0	360.0	2.5	60.0	80.0
1001_000	Reserved										
1001_001	Reserved										
1001_010	Reserved										
1001_011	50.0	66.7	4	200.0	266.6	4	200.0	266.6	4	50.0	66.7
1001_100	50.0	66.7	4	200.0	266.6	4.5	225.0	300.0	4	50.0	66.7
1010_000	Reserved										
1010_001	50.0	66.7	4	200.0	266.6	3	200.0	266.6	3	66.7	88.9
1010_010	50.0	66.7	4	200.0	266.6	3.5	233.3	311.1	3	66.7	88.9
1010_011	50.0	66.7	4	200.0	266.6	4	266.7	355.5	3	66.7	88.9
1010_100	50.0	66.7	4	200.0	266.6	4.5	300.0	400.0	3	66.7	88.9
1011_000	Reserved										
1011_001	50.0	66.7	4	200.0	266.6	2.5	200.0	266.6	2.5	80.0	106.7
1011_010	50.0	66.7	4	200.0	266.6	3	240.0	320.0	2.5	80.0	106.7
1011_011	50.0	66.7	4	200.0	266.6	3.5	280.0	373.3	2.5	80.0	106.7
1011_100	50.0	66.7	4	200.0	266.6	4	320.0	426.6	2.5	80.0	106.7
1011_101	50.0	66.7	4	200.0	266.6	2.5	250.0	333.3	2	100.0	133.3
1011_110	50.0	66.7	4	200.0	266.6	3	300.0	400.0	2	100.0	133.3
1011_111	50.0	66.7	4	200.0	266.6	3.5	350.0	466.6	2	100.0	133.3

**Table 19. Clock Configurations for PCI Agent Mode (PCI\_MODCK=0)<sup>1,2</sup> (continued)**

Mode <sup>3</sup>	PCI Clock (MHz)		CPM Multiplication Factor <sup>4</sup>	CPM Clock (MHz)		CPU Multiplication Factor <sup>5</sup>	CPU Clock (MHz)		Bus Division Factor	Bus Clock (MHz)	
	Low	High		Low	High		Low	High		Low	High
1100_101	50.0	66.7	6	300.0	400.0	4	400.0	533.3	3	100.0	133.3
1100_110	50.0	66.7	6	300.0	400.0	4.5	450.0	599.9	3	100.0	133.3
1100_111	50.0	66.7	6	300.0	400.0	5	500.0	666.6	3	100.0	133.3
1101_000	50.0	66.7	6	300.0	400.0	5.5	550.0	733.3	3	100.0	133.3
1101_001	50.0	66.7	6	300.0	400.0	3.5	420.0	559.9	2.5	120.0	160.0
1101_010	50.0	66.7	6	300.0	400.0	4	480.0	639.9	2.5	120.0	160.0
1101_011	50.0	66.7	6	300.0	400.0	4.5	540.0	719.9	2.5	120.0	160.0
1101_100	50.0	66.7	6	300.0	400.0	5	600.0	799.9	2.5	120.0	160.0
1110_000	50.0	66.7	5	250.0	333.3	2.5	312.5	416.6	2	125.0	166.7
1110_001	50.0	66.7	5	250.0	333.3	3	375.0	500.0	2	125.0	166.7
1110_010	50.0	66.7	5	250.0	333.3	3.5	437.5	583.3	2	125.0	166.7
1110_011	50.0	66.7	5	250.0	333.3	4	500.0	666.6	2	125.0	166.7
1110_100	50.0	66.7	5	250.0	333.3	4	333.3	444.4	3	83.3	111.1
1110_101	50.0	66.7	5	250.0	333.3	4.5	375.0	500.0	3	83.3	111.1
1110_110	50.0	66.7	5	250.0	333.3	5	416.7	555.5	3	83.3	111.1
1110_111	50.0	66.7	5	250.0	333.3	5.5	458.3	611.1	3	83.3	111.1
1100_000	Reserved										
1100_001	Reserved										
1100_010	Reserved										

<sup>1</sup> The “low” values are the minimum allowable frequencies for a given clock mode. The minimum bus frequency in a table entry guarantees only the required minimum CPU operating frequency. The “high” values are for the purpose of illustration only. Users must select a mode and input bus frequency so that the resulting configuration does not exceed the frequency rating of the user’s device. The minimum CPU frequency is 150 MHz for commercial temperature devices and 175 MHz for extended temperature devices. The minimum CPM frequency is 120 MHz.

<sup>2</sup> PCI\_MODCK determines the PCI clock frequency range. See [Table 20](#) for lower range configurations.

<sup>3</sup> MODCK\_H = hard reset configuration word [28–31] (see Section 5.4 in the SoC reference manual). MODCK[1-3] = three hardware configuration pins.

<sup>4</sup> CPM multiplication factor = CPM clock/bus clock

<sup>5</sup> CPU multiplication factor = Core PLL multiplication factor

**Table 20. Clock Configurations for PCI Agent Mode (PCI\_MODCK=1)<sup>1,2</sup>**

Mode <sup>3</sup>	PCI Clock (MHz)		CPM Multiplication Factor <sup>4</sup>	CPM Clock (MHz)		CPU Multiplication Factor <sup>5</sup>	CPU Clock (MHz)		Bus Division Factor	Bus Clock (MHz)	
	MODCK_H-MODCK[1-3]	Low		High	Low		High	Low		High	Low
<b>Default Modes (MODCK_H=0000)</b>											
0000_000	30.0	50.0	4	120.0	200.0	2.5	150.0	250.0	2	60.0	100.0
0000_001	25.0	50.0	4	100.0	200.0	3	150.0	300.0	2	50.0	100.0
0000_010	25.0	50.0	6	150.0	300.0	3	150.0	300.0	3	50.0	100.0
0000_011	25.0	50.0	6	150.0	300.0	4	200.0	400.0	3	50.0	100.0
0000_100	25.0	50.0	6	150.0	300.0	3	180.0	360.0	2.5	60.0	120.0
0000_101	25.0	50.0	6	150.0	300.0	3.5	210.0	420.0	2.5	60.0	120.0
0000_110	25.0	50.0	8	200.0	400.0	3.5	233.3	466.7	3	66.7	133.3
0000_111	25.0	50.0	8	200.0	400.0	3	240.0	480.0	2.5	80.0	160.0
<b>Full Configuration Modes</b>											
0001_001	30.0	50.0	4	120.0	200.0	5	150.0	250.0	4	30.0	50.0
0001_010	25.0	50.0	4	100.0	200.0	6	150.0	300.0	4	25.0	50.0
0001_011	25.0	50.0	4	100.0	200.0	7	175.0	350.0	4	25.0	50.0
0001_100	25.0	50.0	4	100.0	200.0	8	200.0	400.0	4	25.0	50.0
<b>Reserved</b>											
0010_001	25.0	50.0	6	150.0	300.0	3	180.0	360.0	2.5	60.0	120.0
0010_010	25.0	50.0	6	150.0	300.0	3.5	210.0	420.0	2.5	60.0	120.0
0010_011	25.0	50.0	6	150.0	300.0	4	240.0	480.0	2.5	60.0	120.0
0010_100	25.0	50.0	6	150.0	300.0	4.5	270.0	540.0	2.5	60.0	120.0
<b>Reserved</b>											
0011_000	Reserved										
0011_001	37.5	50.0	4	150.0	200.0	3	150.0	200.0	3	50.0	66.7
0011_010	32.1	50.0	4	128.6	200.0	3.5	150.0	233.3	3	42.9	66.7
0011_011	28.1	50.0	4	112.5	200.0	4	150.0	266.7	3	37.5	66.7
0011_100	25.0	50.0	4	100.0	200.0	4.5	150.0	300.0	3	33.3	66.7
<b>Reserved</b>											
0100_000	Reserved										
0100_001	25.0	50.0	6	150.0	300.0	3	150.0	300.0	3	50.0	100.0
0100_010	25.0	50.0	6	150.0	300.0	3.5	175.0	350.0	3	50.0	100.0
0100_011	25.0	50.0	6	150.0	300.0	4	200.0	400.0	3	50.0	100.0

Table 20. Clock Configurations for PCI Agent Mode (PCI\_MODCK=1)<sup>1,2</sup> (continued)

Mode <sup>3</sup>	PCI Clock (MHz)		CPM Multiplication Factor <sup>4</sup>	CPM Clock (MHz)		CPU Multiplication Factor <sup>5</sup>	CPU Clock (MHz)		Bus Division Factor	Bus Clock (MHz)	
	Low	High		Low	High		Low	High		Low	High
0100_100	25.0	50.0	6	150.0	300.0	4.5	225.0	450.0	3	50.0	100.0
0101_000	30.0	50.0	5	150.0	250.0	2.5	150.0	250.0	2.5	60.0	100.0
0101_001	25.0	50.0	5	125.0	250.0	3	150.0	300.0	2.5	50.0	100.0
0101_010	25.0	50.0	5	125.0	250.0	3.5	175.0	350.0	2.5	50.0	100.0
0101_011	25.0	50.0	5	125.0	250.0	4	200.0	400.0	2.5	50.0	100.0
0101_100	25.0	50.0	5	125.0	250.0	4.5	225.0	450.0	2.5	50.0	100.0
0101_101	25.0	50.0	5	125.0	250.0	5	250.0	500.0	2.5	50.0	100.0
0101_110	25.0	50.0	5	125.0	250.0	5.5	275.0	550.0	2.5	50.0	100.0
0110_000	Reserved										
0110_001	25.0	50.0	8	200.0	400.0	3	200.0	400.0	3	66.7	133.3
0110_010	25.0	50.0	8	200.0	400.0	3.5	233.3	466.7	3	66.7	133.3
0110_011	25.0	50.0	8	200.0	400.0	4	266.7	533.3	3	66.7	133.3
0110_100	25.0	50.0	8	200.0	400.0	4.5	300.0	600.0	3	66.7	133.3
0111_000	25.0	50.0	6	150.0	300.0	2	150.0	300.0	2	75.0	150.0
0111_001	25.0	50.0	6	150.0	300.0	2.5	187.5	375.0	2	75.0	150.0
0111_010	25.0	50.0	6	150.0	300.0	3	225.0	450.0	2	75.0	150.0
0111_011	25.0	50.0	6	150.0	300.0	3.5	262.5	525.0	2	75.0	150.0
1000_000	Reserved										
1000_001	25.0	50.0	6	150.0	300.0	2.5	150.0	300.0	2.5	60.0	120.0
1000_010	25.0	50.0	6	150.0	300.0	3	180.0	360.0	2.5	60.0	120.0
1000_011	25.0	50.0	6	150.0	300.0	3.5	210.0	420.0	2.5	60.0	120.0
1000_100	25.0	50.0	6	150.0	300.0	4	240.0	480.0	2.5	60.0	120.0
1000_101	25.0	50.0	6	150.0	300.0	4.5	270.0	540.0	2.5	60.0	120.0
1001_000	Reserved										
1001_001	Reserved										

**Table 20. Clock Configurations for PCI Agent Mode (PCI\_MODCK=1)<sup>1,2</sup> (continued)**

Mode <sup>3</sup>	PCI Clock (MHz)		CPM Multiplication Factor <sup>4</sup>	CPM Clock (MHz)		CPU Multiplication Factor <sup>5</sup>	CPU Clock (MHz)		Bus Division Factor	Bus Clock (MHz)	
	Low	High		Low	High		Low	High		Low	High
1001_010	Reserved										
1001_011	25.0	50.0	8	200.0	400.0	4	200.0	400.0	4	50.0	100.0
1001_100	25.0	50.0	8	200.0	400.0	4.5	225.0	450.0	4	50.0	100.0
1010_000	Reserved										
1010_001	25.0	50.0	8	200.0	400.0	3	200.0	400.0	3	66.7	133.3
1010_010	25.0	50.0	8	200.0	400.0	3.5	233.3	466.7	3	66.7	133.3
1010_011	25.0	50.0	8	200.0	400.0	4	266.7	533.3	3	66.7	133.3
1010_100	25.0	50.0	8	200.0	400.0	4.5	300.0	600.0	3	66.7	133.3
1011_000	Reserved										
1011_001	25.0	50.0	8	200.0	400.0	2.5	200.0	400.0	2.5	80.0	160.0
1011_010	25.0	50.0	8	200.0	400.0	3	240.0	480.0	2.5	80.0	160.0
1011_011	25.0	50.0	8	200.0	400.0	3.5	280.0	560.0	2.5	80.0	160.0
1011_100	25.0	50.0	8	200.0	400.0	4	320.0	640.0	2.5	80.0	160.0
1011_101	25.0	50.0	8	200.0	400.0	2.5	250.0	500.0	2	100.0	200.0
1011_110	25.0	50.0	8	200.0	400.0	3	300.0	600.0	2	100.0	200.0
1011_111	25.0	50.0	8	200.0	400.0	3.5	350.0	700.0	2	100.0	200.0
1100_101	25.0	50.0	6	150.0	300.0	4	200.0	400.0	3	50.0	100.0
1100_110	25.0	50.0	6	150.0	300.0	4.5	225.0	450.0	3	50.0	100.0
1100_111	25.0	50.0	6	150.0	300.0	5	250.0	500.0	3	50.0	100.0
1101_000	25.0	50.0	6	150.0	300.0	5.5	275.0	550.0	3	50.0	100.0
1101_001	25.0	50.0	6	150.0	300.0	3.5	210.0	420.0	2.5	60.0	120.0
1101_010	25.0	50.0	6	150.0	300.0	4	240.0	480.0	2.5	60.0	120.0
1101_011	25.0	50.0	6	150.0	300.0	4.5	270.0	540.0	2.5	60.0	120.0
1101_100	25.0	50.0	6	150.0	300.0	5	300.0	600.0	2.5	60.0	120.0

**Table 20. Clock Configurations for PCI Agent Mode (PCI\_MODCK=1)<sup>1,2</sup> (continued)**

Mode <sup>3</sup>	PCI Clock (MHz)		CPM Multiplication Factor <sup>4</sup>	CPM Clock (MHz)		CPU Multiplication Factor <sup>5</sup>	CPU Clock (MHz)		Bus Division Factor	Bus Clock (MHz)	
	Low	High		Low	High		Low	High		Low	High
1110_000	25.0	50.0	5	125.0	250.0	2.5	156.3	312.5	2	62.5	125.0
1110_001	25.0	50.0	5	125.0	250.0	3	187.5	375.0	2	62.5	125.0
1110_010	28.6	50.0	5	142.9	250.0	3.5	250.0	437.5	2	71.4	125.0
1110_011	25.0	50.0	5	125.0	250.0	4	250.0	500.0	2	62.5	125.0
1110_100	25.0	50.0	5	125.0	250.0	4	166.7	333.3	3	41.7	83.3
1110_101	25.0	50.0	5	125.0	250.0	4.5	187.5	375.0	3	41.7	83.3
1110_110	25.0	50.0	5	125.0	250.0	5	208.3	416.7	3	41.7	83.3
1110_111	25.0	50.0	5	125.0	250.0	5.5	229.2	458.3	3	41.7	83.3
1100_000	Reserved										
1100_001	Reserved										
1100_010	Reserved										

<sup>1</sup> The “low” values are the minimum allowable frequencies for a given clock mode. The minimum bus frequency in a table entry guarantees only the required minimum CPU operating frequency. The “high” values are for the purpose of illustration only. Users must select a mode and input bus frequency so that the resulting configuration does not exceed the frequency rating of the user’s device. The minimum CPU frequency is 150 MHz for commercial temperature devices and 175 MHz for extended temperature devices. The minimum CPM frequency is 120 MHz.

<sup>2</sup> PCI\_MODCK determines the PCI clock frequency range. See [Table 19](#) for higher range configurations.

<sup>3</sup> MODCK\_H = hard reset configuration word [28–31] (see Section 5.4 in the SoC reference manual). MODCK[1-3] = three hardware configuration pins.

<sup>4</sup> CPM multiplication factor = CPM clock/bus clock

<sup>5</sup> CPU multiplication factor = Core PLL multiplication factor

## 8 Pinout

This figure and table show the pin assignments and pinout for the 516 PBGA package.

This figure shows the pinout of the 516 PBGA package as viewed from the top surface.

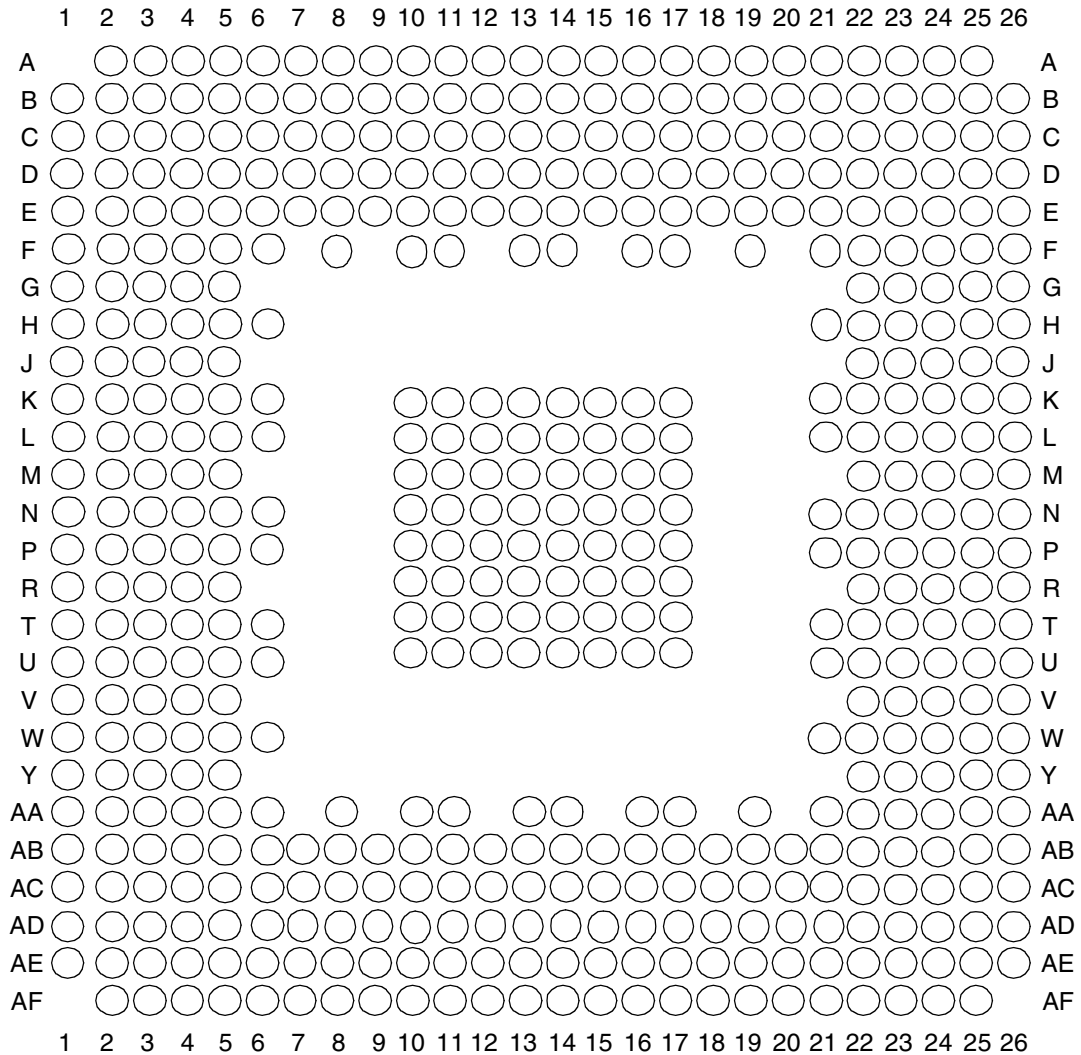

Not to Scale

**Figure 12. Pinout of the 516 PBGA Package (View from Top)**

This table lists the pins of the MPC8272. Note that the pins in the “MPC8272/8271 Only” column relate to Utopia functionality.

**Table 21. Pinout**

Pin Name		Ball
MPC8272/MPC8248 and MPC8271/MPC8247	MPC8272/MPC8271 Only	
$\overline{BR}$		A19
$\overline{BG/IRQ6}$		D2
$\overline{ABB/IRQ2}$		C1

Table 21. Pinout (continued)

Pin Name		Ball
MPC8272/MPC8248 and MPC8271/MPC8247	MPC8272/MPC8271 Only	
	$\overline{TS}$	D1
	A0	A3
	A1	B5
	A2	D8
	A3	C6
	A4	A4
	A5	A6
	A6	B6
	A7	C7
	A8	B7
	A9	A7
	A10	D9
	A11	E11
	A12	C9
	A13	B9
	A14	D11
	A15	A9
	A16	B10
	A17	A10
	A18	B11
	A19	A11
	A20	D12
	A21	A12
	A22	D13
	A23	B13
	A24	C13
	A25	C14
	A26	B14
	A27	D14
	A28	E14
	A29	A14

**Table 21. Pinout (continued)**

Pin Name		Ball
MPC8272/MPC8248 and MPC8271/MPC8247	MPC8272/MPC8271 Only	
	A30	B15
	A31	A15
	TT0	B3
	TT1	E8
	TT2	D7
	TT3	C4
	TT4	E7
	$\overline{\text{TBST}}$	E3
	TSIZ0	E4
	TSIZ1	E5
	TSIZ2	C3
	TSIZ3	D5
	$\overline{\text{AACK}}$	D3
	$\overline{\text{ARTRY}}$	C2
	$\overline{\text{DBG/IRQ7}}$	F16
	$\overline{\text{DBB/IRQ3}}$	D18
	D0	AC1
	D1	AA1
	D2	V3
	D3	R5
	D4	P4
	D5	M4
	D6	J4
	D7	G1
	D8	W6
	D9	Y3
	D10	V1
	D11	N6
	D12	P3
	D13	M2
	D14	J5

Table 21. Pinout (continued)

Pin Name		Ball
MPC8272/MPC8248 and MPC8271/MPC8247	MPC8272/MPC8271 Only	
	D15	G3
	D16	AB3
	D17	Y1
	D18	T4
	D19	T3
	D20	P2
	D21	M1
	D22	J1
	D23	G4
	D24	AB2
	D25	W4
	D26	V2
	D27	T1
	D28	N5
	D29	L1
	D30	H1
	D31	G5
	D32	W5
	D33	W2
	D34	T5
	D35	T2
	D36	N1
	D37	K3
	D38	H2
	D39	F1
	D40	AA2
	D41	W1
	D42	U3
	D43	R2
	D44	N2
	D45	L2

Table 21. Pinout (continued)

Pin Name		Ball
MPC8272/MPC8248 and MPC8271/MPC8247	MPC8272/MPC8271 Only	
D46		H4
D47		F2
D48		AB1
D49		U4
D50		U1
D51		R3
D52		N3
D53		K2
D54		H5
D55		F4
D56		AA3
D57		U5
D58		U2
D59		P5
D60		M3
D61		K4
D62		H3
D63		E1
$\overline{\text{IRQ3}}/\text{CKSTP\_OUT}/\text{EXT\_BR3}$		B16
$\overline{\text{IRQ4}}/\text{CORE\_SRESET}/\text{EXT\_BG3}$		C15
$\overline{\text{IRQ5}}/\text{TBEN}/\text{EXT\_DBG3}/\text{CINT}$		Y4
$\overline{\text{PSDVAL}}$		C19
$\overline{\text{TA}}$		AA4
$\overline{\text{TEA}}$		AB6
$\overline{\text{GBL}}/\text{IRQ1}$		D15
$\overline{\text{CI}}/\text{BADDR29}/\text{IRQ2}$		D16
$\overline{\text{WT}}/\text{BADDR30}/\text{IRQ3}$		C16
$\text{BADDR31}/\text{IRQ5}/\text{CINT}$		E17
$\overline{\text{CPU\_BR}}/\text{INT\_OUT}$		B20
$\overline{\text{CS0}}$		AE6
$\overline{\text{CS1}}$		AD7

Table 21. Pinout (continued)

Pin Name		Ball
MPC8272/MPC8248 and MPC8271/MPC8247	MPC8272/MPC8271 Only	
	$\overline{CS2}$	AF5
	$\overline{CS3}$	AC8
	$\overline{CS4}$	AF6
	$\overline{CS5}$	AD8
	$\overline{CS6/BCTL1/SMI}$	AC9
	$\overline{CS7/TLBISYNC}$	AB9
	BADDR27/ $\overline{IRQ1}$	AB8
	BADDR28/ $\overline{IRQ2}$	AC7
	ALE/ $\overline{IRQ4}$	AF4
	$\overline{BCTL0}$	AF3
	$\overline{PWE0/PSDDQM0/PBS0}$	AD6
	$\overline{PWE1/PSDDQM1/PBS1}$	AE5
	$\overline{PWE2/PSDDQM2/PBS2}$	AE3
	$\overline{PWE3/PSDDQM3/PBS3}$	AF2
	$\overline{PWE4/PSDDQM4/PBS4}$	AC6
	$\overline{PWE5/PSDDQM5/PBS5}$	AC5
	$\overline{PWE6/PSDDQM6/PBS6}$	AD4
	$\overline{PWE7/PSDDQM7/PBS7}$	AB5
	PSDA10/PGPL0	AE2
	$\overline{PSDWE}/PGPL1$	AD3
	$\overline{POE/PSDRAS}/PGPL2$	AB4
	$\overline{PSDCAS}/PGPL3$	AC3
	$\overline{PGTA}/PUPMWAIT/PGPL4$	AD2
	PSDAMUX/PGPL5	AC2
	$\overline{PCI\_MODE}^1$	AD22
	PCI_CFG0 ( $\overline{PCI\_HOST\_EN}$ )	AC21
	PCI_CFG1 ( $\overline{PCI\_ARB\_EN}$ )	AE22
	PCI_CFG2 (DLL_ENABLE)	AE23
	PCI_PAR	AF12
	$\overline{PCI\_FRAME}$	AD15
	$\overline{PCI\_TRDY}$	AF16

**Table 21. Pinout (continued)**

Pin Name		Ball
MPC8272/MPC8248 and MPC8271/MPC8247	MPC8272/MPC8271 Only	
	PCI_IRDY	AF15
	PCI_STOP	AE15
	PCI_DEVSEL	AE14
	PCI_IDSEL	AC17
	PCI_PERR	AD14
	PCI_SERR	AD13
	PCI_REQ0	AE20
	PCI_REQ1/CPCI_HS_ES	AF14
	PCI_GNT0	AD20
	PCI_GNT1/CPCI_HS_LED	AE13
	PCI_GNT2/CPCI_HS_ENUM	AF21
	PCI_RST	AF22
	PCI_INTA	AE21
	PCI_REQ2	AB14
	DLLOUT	AC22
	PCI_AD0	AF7
	PCI_AD1	AE10
	PCI_AD2	AB10
	PCI_AD3	AD10
	PCI_AD4	AE9
	PCI_AD5	AF8
	PCI_AD6	AC10
	PCI_AD7	AE11
	PCI_AD8	AB11
	PCI_AD9	AF10
	PCI_AD10	AF9
	PCI_AD11	AB12
	PCI_AD12	AC12
	PCI_AD13	AD12
	PCI_AD14	AF11
	PCI_AD15	AB13

Table 21. Pinout (continued)

Pin Name		Ball
MPC8272/MPC8248 and MPC8271/MPC8247	MPC8272/MPC8271 Only	
	PCI_AD16	AE16
	PCI_AD17	AF17
	PCI_AD18	AD16
	PCI_AD19	AC16
	PCI_AD20	AF18
	PCI_AD21	AB16
	PCI_AD22	AD17
	PCI_AD23	AF19
	PCI_AD24	AB17
	PCI_AD25	AF20
	PCI_AD26	AE19
	PCI_AD27	AC18
	PCI_AD28	AB18
	PCI_AD29	AD19
	PCI_AD30	AD21
	PCI_AD31	AC20
	$\overline{\text{PCI\_C0/BE0}}$	AE12
	$\overline{\text{PCI\_C1/BE1}}$	AF13
	$\overline{\text{PCI\_C2/BE2}}$	AC15
	$\overline{\text{PCI\_C3/BE3}}$	AE18
	$\overline{\text{IRQ0/NMI\_OUT}}$	A17
	$\overline{\text{TRST}}^2$	E21
	TCK	B22
	TMS	C23
	TDI	B24
	TDO	A22
	$\overline{\text{TRIS}}$	B23
	$\overline{\text{PORESET}}^2/\overline{\text{PCI\_RST}}$	C24
	$\overline{\text{HRESET}}$	D22
	$\overline{\text{SRESET}}$	F22
	$\overline{\text{RSTCONF}}$	A24

**Table 21. Pinout (continued)**

Pin Name		Ball
MPC8272/MPC8248 and MPC8271/MPC8247	MPC8272/MPC8271 Only	
MODCK1/ $\overline{\text{RSRV}}$ /TC0/ $\overline{\text{BNKSEL0}}$		A20
MODCK2/CSE0/TC1/ $\overline{\text{BNKSEL1}}$		C20
MODCK3/CSE1/TC2/ $\overline{\text{BNKSEL2}}$		A21
CLKIN1		D21
PA8/SMRXD2		AF25 <sup>3</sup>
PA9/SMTXD2		AA22 <sup>3</sup>
PA10/MSNUM5	FCC1_UT_RXD0	AB23 <sup>3</sup>
PA11/MSNUM4	FCC1_UT_RXD1	AD26 <sup>3</sup>
PA12/MSNUM3	FCC1_UT_RXD2	AD25 <sup>3</sup>
PA13/MSNUM2	FCC1_UT_RXD3	AA24 <sup>3</sup>
PA14/FCC1_MII_HDLC_RXD3	FCC1_UT_RXD4	W22 <sup>3</sup>
PA15/FCC1_MII_HDLC_RXD2	FCC1_UT_RXD5	Y24 <sup>3</sup>
PA16/FCC1_MII_HDLC_RXD1	FCC1_UT_RXD6	T22 <sup>3</sup>
PA17/FCC1_MII_HDLC_RXD0/ FCC1_MII_TRAN_RXD/FCC1_RMII_RX D0	FCC1_UT_RXD7	W26 <sup>3</sup>
PA18/FCC1_MII_HDLC_TXD0/FCC1_MII _TRAN_TXD/ FCC1_RMII_TXD0	FCC1_UT_TXD7	V26 <sup>3</sup>
PA19/FCC1_MII_HDLC_TXD1/FCC1_RM II_TXD1	FCC1_UT_TXD6	R23 <sup>3</sup>
PA20/FCC1_MII_HDLC_TXD2	FCC1_UT_TXD5	P25 <sup>3</sup>
PA21/FCC1_MII_HDLC_TXD3	FCC1_UT_TXD4	N22 <sup>3</sup>
PA22	FCC1_UT_TXD3	N26 <sup>3</sup>
PA23	FCC1_UT_TXD2	N23 <sup>3</sup>
PA24/MSNUM1	FCC1_UT_TXD1	H26 <sup>3</sup>
PA25/MSNUM0	FCC1_UT_TXD0	G25 <sup>3</sup>
PA26/FCC1_MII_RMII_RX_ER	FCC1_UT_RXCLAV	L22 <sup>3</sup>
PA27/FCC1_MII_RX_DV/FCC1_RMII_CR S_DV	FCC1_UT_RXSOC	G24 <sup>3</sup>
PA28/FCC1_MII_RMII_TX_EN	FCC1_UT_RXENB	G23 <sup>3</sup>
PA29/FCC1_MII_TX_ER	$\overline{\text{FCC1\_UT\_TXSOC}}$	B26 <sup>3</sup>
PA30/FCC1_MII_CRS/ $\overline{\text{FCC1\_RTS}}$	FCC1_UT_TXCLAV	A25 <sup>3</sup>

Table 21. Pinout (continued)

Pin Name		Ball
MPC8272/MPC8248 and MPC8271/MPC8247	MPC8272/MPC8271 Only	
PA31/FCC1_MII_COL	$\overline{\text{FCC1\_UT\_TXENB}}$	G22 <sup>3</sup>
PB18/FCC2_MII_HDLC_RXD3		T25 <sup>3</sup>
PB19/FCC2_MII_HDLC_RXD2		P22 <sup>3</sup>
PB20/FCC2_MII_HDLC_RMII_RXD1		L25 <sup>3</sup>
PB21/FCC2_MII_HDLC_RMII_RXD0/FCC2_TRAN_RXD		J26 <sup>3</sup>
PB22/FCC2_MII_HDLC_TXD0/FCC2_TRAN_TXD/ FCC2_RMII_TXD0		U23 <sup>3</sup>
PB23/FCC2_MII_HDLC_TXD1/FCC2_RMII_TXD1		U26 <sup>3</sup>
PB24/FCC2_MII_HDLC_TXD2/L1RSYNCB2		M24 <sup>3</sup>
PB25/FCC2_MII_HDLC_TXD3/L1TSYNCB2		M23 <sup>3</sup>
PB26/FCC2_MII_CRS/L1RXDB2		H24 <sup>3</sup>
PB27/FCC2_MII_COL/L1TXDB2		E25 <sup>3</sup>
PB28/FCC2_MII_RMII_RX_ER/ $\overline{\text{FCC2\_RTS}}$ /TXD1		D26 <sup>3</sup>
PB29/FCC2_MII_RMII_TX_EN		K21 <sup>3</sup>
PB30/FCC2_MII_RX_DV/FCC2_RMII_CRS_DV		D24 <sup>3</sup>
PB31/FCC2_MII_TX_ER		E23 <sup>3</sup>
PC0/ $\overline{\text{DREQ3}}$ /BRGO7/ $\overline{\text{SMSYN1}}$ /L1CLKOA2		AF23 <sup>3</sup>
PC1/BRGO6/ $\overline{\text{L1RQA2}}$		AD23 <sup>3</sup>
PC4/SMRXD1/SI2_L1ST4/ $\overline{\text{FCC2\_CD}}$		AB22 <sup>3</sup>
PC5/SMTXD1/SI2_L1ST3/ $\overline{\text{FCC2\_CTS}}$		AE24 <sup>3</sup>
PC6/ $\overline{\text{FCC1\_CD}}$ /SI2_L1ST2	FCC1_UT_RXADDR2	AF24 <sup>3</sup>
PC7/ $\overline{\text{FCC1\_CTS}}$	FCC1_UT_TXADDR2	AE26 <sup>3</sup>
PC8/ $\overline{\text{CD4}}$ /RTS1/SI2_L1ST2/ $\overline{\text{CTS3}}$		AC24 <sup>3</sup>
PC9/ $\overline{\text{CTS4}}$ /L1TSYNCA2		AA23 <sup>3</sup>
PC10/ $\overline{\text{CD3}}$ /USB_RN		AB25 <sup>3</sup>
PC11/ $\overline{\text{CTS3}}$ /USB_RP/L1TXD3A2		V22 <sup>3</sup>
PC12	FCC1_UT_RXADDR1	AA26 <sup>3</sup>
PC13/BRGO5	FCC1_UT_TXADDR1	V23 <sup>3</sup>
PC14/ $\overline{\text{CD1}}$	FCC1_UT_RXADDR0	W24 <sup>3</sup>
PC15/ $\overline{\text{CTS1}}$	FCC1_UT_TXADDR0	U24 <sup>3</sup>
PC16/CLK16		T23 <sup>3</sup>

**Table 21. Pinout (continued)**

Pin Name		Ball
MPC8272/MPC8248 and MPC8271/MPC8247	MPC8272/MPC8271 Only	
PC17/CLK15/BRGO8/ $\overline{DONE2}$		T26 <sup>3</sup>
PC18/CLK14/ $\overline{TGATE2}$		R26 <sup>3</sup>
PC19/CLK13/BRGO7/ $\overline{TGATE1}$		P24 <sup>3</sup>
PC20/CLK12/ $\overline{USB0E}$		L26 <sup>3</sup>
PC21/CLK11/BRGO6/CP_INT		L24 <sup>3</sup>
PC22/CLK10/ $\overline{DONE3}$	FCC1_UT_TXPRTY	L23 <sup>3</sup>
PC23/CLK9/BRGO5/ $\overline{DACK3}/\overline{CD1}$		K24 <sup>3</sup>
PC24/CLK8/TIN3/ $\overline{TOUT4}/DREQ2/BRGO1$		K23 <sup>3</sup>
PC25/CLK7/BRGO4/ $\overline{DACK2}/SPISEL$		F26 <sup>3</sup>
PC26/CLK6/ $\overline{TOUT3}/TMCLK$		H23 <sup>3</sup>
PC27/CLK5/BRGO3/ $\overline{TOUT1}$	FCC1_UT_RXPRTY	K22 <sup>3</sup>
PC28/CLK4/TIN1/ $\overline{TOUT2}/SPICLK$		D25 <sup>3</sup>
PC29/CLK3/TIN2/BRGO2/ $\overline{CTS1}$		F24 <sup>3</sup>
PD7/SMSYN2	FCC1_UT_TXADDR3	AB21 <sup>3</sup>
PD14/I2CSCL		AC26 <sup>3</sup>
PD15/I2CSDA		Y23 <sup>3</sup>
PD16/SPIMISO	FCC1_UT_TXPRTY	AA25 <sup>3</sup>
PD17/BRGO2/SPIMOSI	FCC1_UT_RXPRTY	Y26 <sup>3</sup>
PD18/SPICLK	FCC1_UT_RXADDR4	W25 <sup>3</sup>
PD19/SPISEL/BRGO1	FCC1_UT_TXADDR4	V25 <sup>3</sup>
PD20/ $\overline{RTS4}/L1RSYNCA2$		R24 <sup>3</sup>
PD21/TXD4/L1RXD0A2		P23 <sup>3</sup>
PD22/RXD4/L1TXD0A2		N25 <sup>3</sup>
PD23/ $\overline{RTS3}/USB_TP$		K26 <sup>3</sup>
PD24/TXD3/USB_TN		K25 <sup>3</sup>
PD25/RXD3/USB_RXD		J25 <sup>3</sup>
PD29/ $\overline{RTS1}$	FCC1_UT_RXADDR3	C26 <sup>3</sup>
PD30/TXD1		E24 <sup>3</sup>
PD31/RXD1		B25 <sup>3</sup>
VCCSYN		C18
VCCSYN1		K6

**Table 21. Pinout (continued)**

Pin Name		Ball
MPC8272/MPC8248 and MPC8271/MPC8247	MPC8272/MPC8271 Only	
CLKIN2		C21
No connect <sup>4</sup>		D19 <sup>4</sup> , J3 <sup>4</sup> , AD24 <sup>5</sup>
I/O power		B4, F3, J2, N4, AD1, AD5, AE8, AC13, AD18, AB24, AB26, W23, R25, M25, F25, C25, C22, B17, B12, B8, E6, F6, H6, L5, L6, P6, T6, U6, V5, Y5, AA6, AA8, AA10, AA11, AA14, AA16, AA17, AB19, AB20, W21, U21, T21, P21, N21, M22, J22, H21, F21, F19, F17, E16, F14, E13, E12, F10, E10, E9
Core Power		F5, K5, M5, AA5, AB7, AA13, AA19, AA21, Y22, AC25, U22, R22, L21, H22, E22, E20, E15, F13, F11, F8, L3, V4, W3, AC11, AD11, AB15, U25, T24, J24, H25, F23, B19, D17, C17, D10, C10
Ground		E19, E2, K1, Y2, AE1, AE4, AD9, AC14, AE17, AC19, AE25, V24, P26, M26, G26, E26, B21, C12, C11, C8, A8, B18, A18, A2, B1, B2, A5, C5, D4, D6, G2, L4, P1, R1, R4, AC4, AE7, AC23, Y25, N24, J23, A23, D23, D20, E18, A13, A16, K10, K11, K12, K13, K14, K15, K16, K17, L10, L11, L12, L13, L14, L15, L16, L17, M10, M11, M12, M13, M14, M15, M16, M17, N10, N11, N12, N13, N14, N15, N16, N17, P10, P11, P12, P13, P14, P15, P16, P17, R10, R11, R12, R13, R14, R15, R16, R17, T10, T11, T12, T13, T14, T15, T16, T17, U10, U11, U12, U13, U14, U15, U16, U17

<sup>1</sup> Must be tied to ground.

<sup>2</sup> Should be tied to VDDH via a 2K  $\Omega$  external pull-up resistor.

<sup>3</sup> The default configuration of the CPM pins (PA[8–31], PB[18–31], PC[0–1,4–29], PD[7–25, 29–31]) is input. To prevent excessive DC current, it is recommended either to pull unused pins to GND or VDDH, or to configure them as outputs.

<sup>4</sup> This pin is not connected. It should be left floating.

<sup>5</sup> Must be pulled down or left floating

# 9 Package Description

This figure shows the side profile of the PBGA package to indicate the direction of the top surface view.

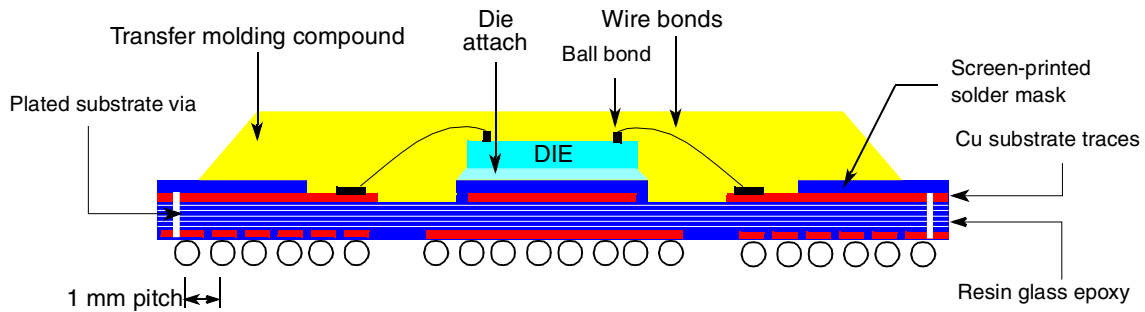

Figure 13. Side View of the PBGA Package Remove

## 9.1 Package Parameters

This table provides package parameters.

Table 22. Package Parameters

Code	Type	Outline (mm)	Interconnects	Pitch (mm)	Nominal Unmounted Height (mm)
VR, ZQ	PBGA	27 x 27	516	1	2.25

### NOTE: Temperature Reflow for the VR Package

In the VR package, sphere composition is lead-free (see [Table 2](#)). This requires higher temperature reflow than what is required for other PowerQUICC II packages. Consult “Freescale PowerQUICC II Pb-Free Packaging Information” (MPC8250PBFREEPKG) available on [www.freescale.com](http://www.freescale.com).

## 9.2 Mechanical Dimensions

This figure provides the mechanical dimensions and bottom surface nomenclature of the 516 PBGA package.

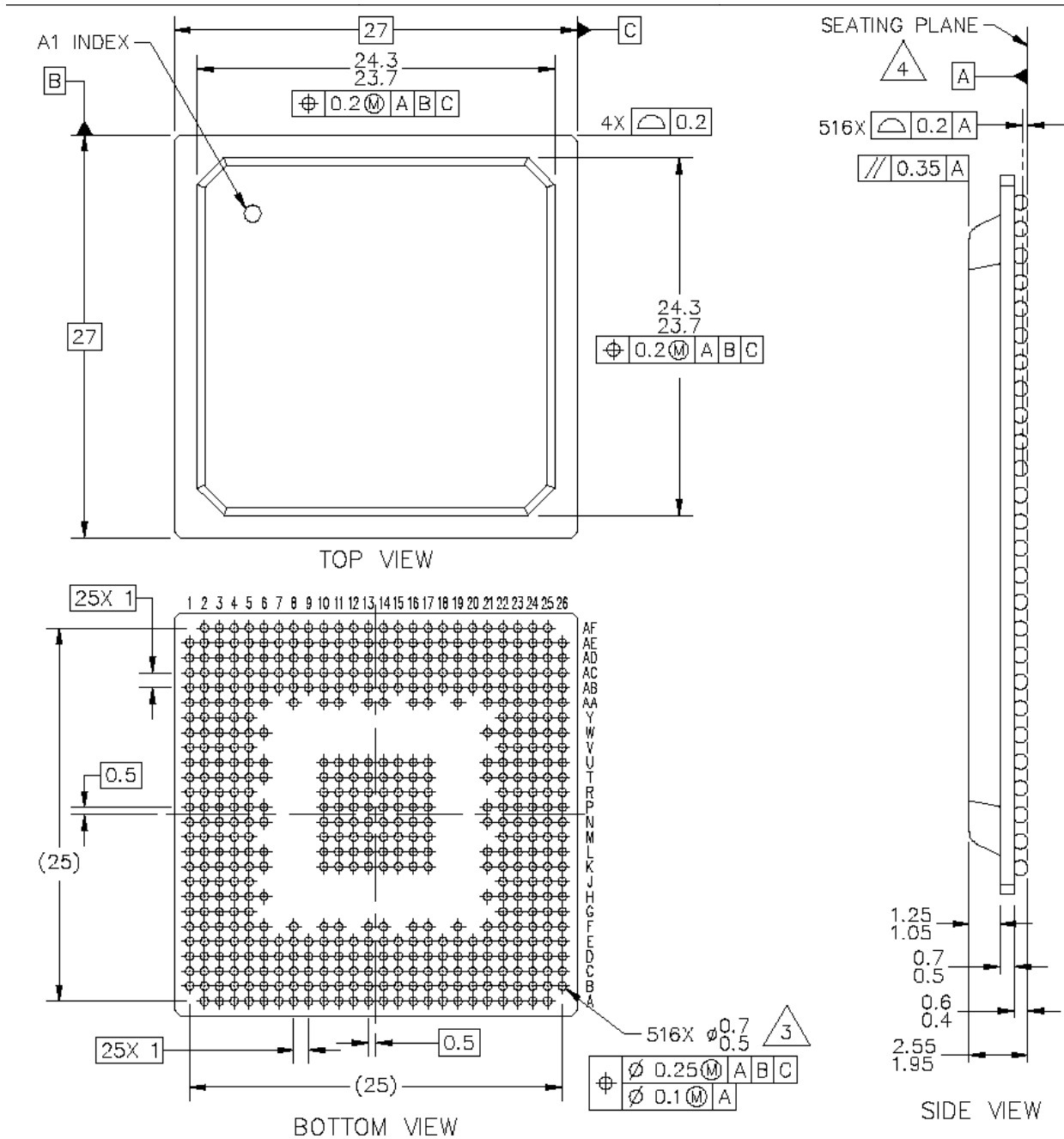

Figure 14. Mechanical Dimensions and Bottom Surface Nomenclature—516 PBGA

## 10 Ordering Information

This figure provides an example of the Freescale part numbering nomenclature for the SoC. In addition to the processor frequency, the part numbering scheme also consists of a part modifier that indicates any enhancement(s) in the part from the original production design. Each part number also contains a revision code that refers to the die mask revision number and is specified in the part numbering scheme for identification purposes only. For more information, contact your local Freescale sales office.

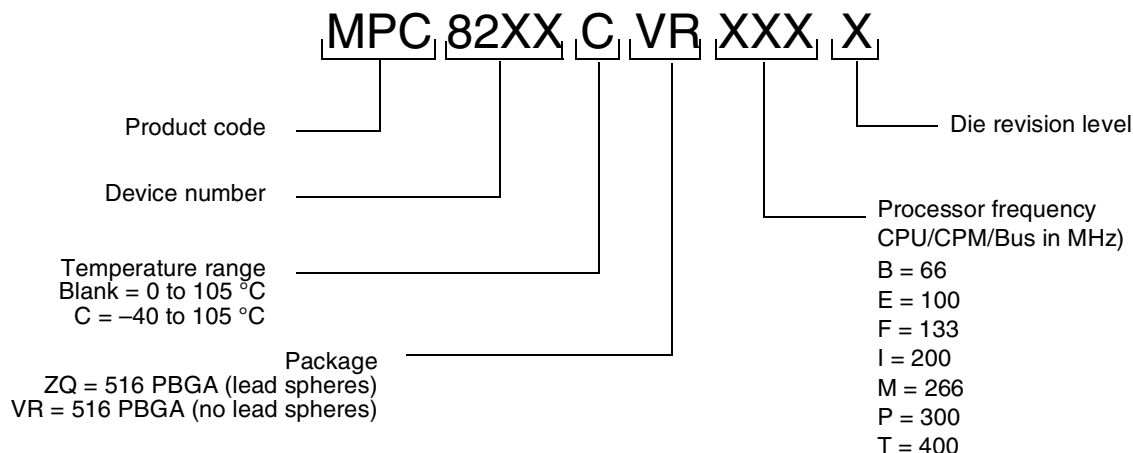

Figure 15. Freescale Part Number Key

## 11 Document Revision History

This table summarizes changes to this document.

Table 23. Document Revision History

Revision	Date	Substantive Changes
3	09/2011	In <a href="#">Figure 15</a> , "Freescale Part Number Key," added speed decoding information below processor frequency information.
2	12/2008	<ul style="list-style-type: none"> <li>Modified <a href="#">Figure 5</a>, "SCC/SMC/SPI/I2C External Clock Diagram," and added second section of figure notes.</li> <li>In <a href="#">Table 12</a>, modified "Data bus in pipeline mode" row and showed 66 MHz as "N/A."</li> <li>In <a href="#">Section 10</a>, "Ordering Information," added "F = 133" to CPU/CPM/Bus Frequency.</li> <li>Added footnote concerning CPM_CLK/PCI_CLK ratio to column "PCI Division Factor" in <a href="#">Table 17</a>, "Clock Configurations for PCI Host Mode (PCI_MODCK=0)," and <a href="#">Table 18</a>, "Clock Configurations for PCI Host Mode (PCI_MODCK=1)."</li> <li>Removed overbar from DLL_ENABLE in <a href="#">Table 21</a>, "Pinout."</li> </ul>
1.5	12/2006	<ul style="list-style-type: none"> <li><a href="#">Section 6</a>, "AC Electrical Characteristics," removed deratings statement and clarified AC timing descriptions.</li> </ul>
1.4	05/2006	<ul style="list-style-type: none"> <li>Added row for 133 MHz configurations to <a href="#">Table 8</a>.</li> </ul>
1.3	02/2006	<ul style="list-style-type: none"> <li>Inserted <a href="#">Section 6.3</a>, "JTAG Timings."</li> </ul>

**Table 23. Document Revision History (continued)**

Revision	Date	Substantive Changes
1.2	09/2005	<ul style="list-style-type: none"> <li>Added 133-MHz to the list of frequencies in the opening sentence of <a href="#">Section 6, “AC Electrical Characteristics”</a>.</li> <li>Added 133 MHz columns to <a href="#">Table 9</a>, <a href="#">Table 11</a>, <a href="#">Table 12</a>, and <a href="#">Table 13</a>.</li> <li>Added footnote 2 to <a href="#">Table 13</a>.</li> <li>Added the conditions note directly above <a href="#">Table 12</a>.</li> </ul>
1.1	01/2005	<ul style="list-style-type: none"> <li>Modification for correct display of assertion level (“<math>\overline{\text{overbar}}</math>”) for some signals</li> </ul>
1.0	12/2004	<ul style="list-style-type: none"> <li>Section 1.1: Added 8:1 ratio to Internal CPM/bus clock multiplier values</li> <li>Section 2: removed voltage tracking note</li> <li><a href="#">Table 3</a>: Note 2 updated regarding VDD/VCCSYN relationship to VDDH during power-on reset</li> <li><a href="#">Table 4</a>: Updated VDD and VCCSYN to 1.425 V - 1.575 V</li> <li><a href="#">Table 8</a>: Note 2 updated to reflect VIH=2.5 for TCK, TRST, PORESET; request for external pull-up removed.</li> <li>Section 4.6: Updated description of layout practices</li> <li><a href="#">Table 8</a>: Note 3 added regarding IIC compatibility</li> <li><a href="#">Table 8</a>: Updated nominal and maximum power dissipation values</li> <li><a href="#">Table 9</a>: updated PCI impedance to 27<math>\Omega</math>, updated 60x and MEMC values and added note to reflect configurable impedance</li> <li>Section 6: Added sentence providing derating factor</li> <li>Section 6.1: added Note: Rise/Fall Time on CPM Input Pins</li> <li><a href="#">Table 9</a>: updated values for following specs: sp36b, sp37a, sp38a, sp39a, sp38b, sp40, sp41, sp42, sp43, sp42a</li> <li><a href="#">Table 11</a>: updated values for following specs: sp16a, sp16b, sp18a, sp18b, sp20, sp21, sp22</li> <li>Section 6.2: added spread spectrum clocking note</li> <li>Section 6.2: added CLKIN jitter note</li> <li><a href="#">Table 12</a>: combined specs sp11 and sp11a</li> <li><a href="#">Table 13</a>: sp30 Data Bus minimum delay values changed to 0.8</li> <li>Section 7: unit of ns added to Tval notes</li> <li>Section 7: Updated all notes to reflect updated CPU Fmin of 150 MHz commercial temp devices, 175 MHz extended temp; CPM Fmin of 120 MHz.</li> <li><a href="#">Section 7, “Clock Configuration Modes”</a>: Updated all table footnotes reflect updated CPU Fmin of 150 MHz commercial temp devices, 175 MHz extended temp; CPM Fmin of 120 MHz.</li> <li><a href="#">Table 21</a>: correct superscript of footnote number after pin AD22</li> <li><a href="#">Table 21</a>: remove DONE3 from PC12</li> <li><a href="#">Table 21</a>: signals referring to TDMs C2 and D2 removed</li> </ul>

**Table 23. Document Revision History (continued)**

Revision	Date	Substantive Changes
0.2	12/2003	<ul style="list-style-type: none"> <li>• <a href="#">Table 1</a>: New</li> <li>• <a href="#">Table 2</a>: New</li> <li>• <a href="#">Table 4</a>: Modification of VDD and VCCSYN to 1.45–1.60 V</li> <li>• <a href="#">Table 8</a>: Addition of note 2 regarding <math>\overline{\text{TRST}}</math> and <math>\overline{\text{PORESET}}</math> (see <math>V_{IH}</math> row of <a href="#">Table 8</a>)</li> <li>• <a href="#">Table 8</a> and <a href="#">Table 21</a>: Addition of muxed signals  CPCI_HS_ES to <math>\overline{\text{PCI\_REQ1}}</math> (AF14)  CPCI_HS_LED to <math>\overline{\text{PCI\_GNT1}}</math> (AE13)  CPCI_HS_ENUM to <math>\overline{\text{PCI\_GNT2}}</math> (AF21)</li> <li>• <a href="#">Table 8</a> and <a href="#">Table 21</a>: Modification of PCI signal names for consistency with PCI signal names on other PowerQUICC II devices:  <math>\overline{\text{PCI\_CFG0}}</math> (<math>\overline{\text{PCI\_HOST\_EN}}</math>) (AC21)  <math>\overline{\text{PCI\_CFG1}}</math> (<math>\overline{\text{PCI\_ARB\_EN}}</math>) (AE22)  <math>\overline{\text{PCI\_CFG2}}</math> (DLL_ENABLE) (AE23)  <math>\overline{\text{PCI\_PAR}}</math> (AF12)  <math>\overline{\text{PCI\_FRAME}}</math> (AD15)  <math>\overline{\text{PCI\_TRDY}}</math> (AF16)  <math>\overline{\text{PCI\_IRDY}}</math> (AF15)  <math>\overline{\text{PCI\_STOP}}</math> (AE15)  <math>\overline{\text{DEVSEL}}</math> (AE14)  <math>\overline{\text{PCI\_IDSEL}}</math> (AC17)  <math>\overline{\text{PCI\_PERR}}</math> (AD14)  <math>\overline{\text{PCI\_SERR}}</math> (AD13)  <math>\overline{\text{PCI\_REQ0-2}}</math> (AAE20, AF14, AB14)  <math>\overline{\text{PCI\_GNT0-2}}</math> (AD20, AE13, AF21)  <math>\overline{\text{PCI\_RST}}</math> (AF22)  <math>\overline{\text{PCI\_INTA}}</math> (AE21)  <math>\overline{\text{PCI\_C0-3}}</math> (AE12, AF13, AC15, AE18)  <math>\overline{\text{PCI\_AD0-31}}</math></li> <li>• <a href="#">Table 8</a> and <a href="#">Table 21</a>: Corrected assertion level (added “<math>\overline{\text{ ”</math>) <math>\overline{\text{PCI\_HOST\_EN}}</math> (AC21) and <math>\overline{\text{PCI\_ARB\_EN}}</math> (AE22)</li> <li>• <a href="#">Table 7</a>: Addition of <math>R_{\theta JT}</math> and note 4</li> <li>• Sections 4.1–4.5 and 4.7 on thermal characteristics: New</li> <li>• <a href="#">Section 7, “Clock Configuration Modes”</a>: Modification to first paragraph. Note that <math>\overline{\text{PCI\_MODCK}}</math> is a bit in the Hard Reset Configuration Word. It is not an input signal as it is in the MPC8280 Family and MPC8260 Family.</li> <li>• Addition of “Note: Temperature Reflow for the VR Package” on page 56</li> <li>• <a href="#">Table 21</a>: Addition of note 2 to <math>\overline{\text{TRST}}</math> (E21) and <math>\overline{\text{PORESET}}</math> (C24)</li> <li>• <a href="#">Table 21</a>: Removal of Thermal0 (D19) and Thermal1(J3). These pins are now “No connects.” Note 4 unchanged.</li> <li>• <a href="#">Table 21</a>: Removal of Spare0 (AD24). This pin is now a “No connect.” Note 5 unchanged.</li> <li>• <a href="#">Table 21</a>: Addition of <math>\overline{\text{PCI\_MODE}}</math> (AD22). This pin was previously listed as “Ground.” Addition of note 1.</li> </ul>
0.1	9/2003	<ul style="list-style-type: none"> <li>• Addition of the MPC8271 and the MPC8247 (these devices do not have a security engine)</li> <li>• <a href="#">Table 8</a>: Addition of note 2 to <math>V_{IH}</math></li> <li>• <a href="#">Table 8</a>: Changed <math>I_{OL}</math> for 60x signals to 6.0 mA</li> <li>• Modification of note 1 for <a href="#">Table 17</a>, <a href="#">Table 18</a>, <a href="#">Table 19</a>, and <a href="#">Table 20</a></li> <li>• <a href="#">Table 21</a>: Addition of ball AD9 to GND. In rev 0 of this document, AD8 was listed as assigned to both <math>\overline{\text{CS5}}</math> and GND. AD8 is only assigned to <math>\overline{\text{CS5}}</math>.</li> <li>• <a href="#">Table 21</a>: Addition of note 4 to Thermal0 (D19) and Thermal1(J3)</li> <li>• Addition of ZQ package code to <a href="#">Figure 15</a></li> </ul>
0	5/2003	NDA release

## How to Reach Us:

### Home Page:

[www.freescale.com](http://www.freescale.com)

### Web Support:

<http://www.freescale.com/support>

### USA/Europe or Locations Not Listed:

Freescale Semiconductor, Inc.  
 Technical Information Center, EL516  
 2100 East Elliot Road  
 Tempe, Arizona 85284  
 1-800-521-6274 or  
 +1-480-768-2130  
[www.freescale.com/support](http://www.freescale.com/support)

### Europe, Middle East, and Africa:

Freescale Halbleiter Deutschland GmbH  
 Technical Information Center  
 Schatzbogen 7  
 81829 Muenchen, Germany  
 +44 1296 380 456 (English)  
 +46 8 52200080 (English)  
 +49 89 92103 559 (German)  
 +33 1 69 35 48 48 (French)  
[www.freescale.com/support](http://www.freescale.com/support)

### Japan:

Freescale Semiconductor Japan Ltd.  
 Headquarters  
 ARCO Tower 15F  
 1-8-1, Shimo-Meguro, Meguro-ku  
 Tokyo 153-0064  
 Japan  
 0120 191014 or  
 +81 3 5437 9125  
[support.japan@freescale.com](mailto:support.japan@freescale.com)

### Asia/Pacific:

Freescale Semiconductor China Ltd.  
 Exchange Building 23F  
 No. 118 Jianguo Road  
 Chaoyang District  
 Beijing 100022  
 China  
 +86 10 5879 8000  
[support.asia@freescale.com](mailto:support.asia@freescale.com)

### For Literature Requests Only:

Freescale Semiconductor  
 Literature Distribution Center  
 1-800 441-2447 or  
 +1-303-675-2140  
 Fax: +1-303-675-2150  
[LDCForFreescaleSemiconductor@hibbertgroup.com](mailto:LDCForFreescaleSemiconductor@hibbertgroup.com)

Information in this document is provided solely to enable system and software implementers to use Freescale Semiconductor products. There are no express or implied copyright licenses granted hereunder to design or fabricate any integrated circuits or integrated circuits based on the information in this document.

Freescale Semiconductor reserves the right to make changes without further notice to any products herein. Freescale Semiconductor makes no warranty, representation or guarantee regarding the suitability of its products for any particular purpose, nor does Freescale Semiconductor assume any liability arising out of the application or use of any product or circuit, and specifically disclaims any and all liability, including without limitation consequential or incidental damages. "Typical" parameters which may be provided in Freescale Semiconductor data sheets and/or specifications can and do vary in different applications and actual performance may vary over time. All operating parameters, including "Typicals" must be validated for each customer application by customer's technical experts. Freescale Semiconductor does not convey any license under its patent rights nor the rights of others. Freescale Semiconductor products are not designed, intended, or authorized for use as components in systems intended for surgical implant into the body, or other applications intended to support or sustain life, or for any other application in which the failure of the Freescale Semiconductor product could create a situation where personal injury or death may occur. Should Buyer purchase or use Freescale Semiconductor products for any such unintended or unauthorized application, Buyer shall indemnify and hold Freescale Semiconductor and its officers, employees, subsidiaries, affiliates, and distributors harmless against all claims, costs, damages, and expenses, and reasonable attorney fees arising out of, directly or indirectly, any claim of personal injury or death associated with such unintended or unauthorized use, even if such claim alleges that Freescale Semiconductor was negligent regarding the design or manufacture of the part.

Freescale, the Freescale logo, CodeWarrior, ColdFire, PowerQUICC, QorIQ, StarCore, and Symphony are trademarks of Freescale Semiconductor, Inc., Reg. U.S. Pat. & Tm. Off. CoreNet, QorIQ Converge, QUICC Engine, and VortiQa are trademarks of Freescale Semiconductor, Inc. All other product or service names are the property of their respective owners. The Power Architecture and Power.org word marks and the Power and Power.org logos and related marks are trademarks and service marks licensed by Power.org.

© 2002–2011 Freescale Semiconductor, Inc.



## Looking for pricing, stock, or lifecycle information?

Click below to explore more details on WIN SOURCE:

⊖ [View MPC8248VRPIEA on WIN SOURCE](#)

⊖ [NXP / Nexperia Information](#)

## Optimize Your Supply Chain with WIN SOURCE Solutions

- ✓ Global Sourcing Solution
- ✓ Obsolete Management
- ✓ Cost Control Management
- ✓ Shortage Management
- ✓ Alternative Solution
- ✓ Excess Inventory Management