



**THE DATASHEET OF
CY7B9940V-2AXC**



High-Speed Multi-frequency PLL Clock Buffer

Features

- 12–100 MHz (CY7B9930V), or 24–200 MHz (CY7B9940V) input/output operation
- Matched pair output skew < 200 ps
- Zero input-to-output delay
- 10 LVTTTL 50% duty-cycle outputs capable of driving 50 Ω terminated lines
- Commercial temperature range with eight outputs at 200 MHz
- Industrial temperature range with eight outputs at 200 MHz
- 3.3 V LVTTTL/LV differential (LVPECL), fault-tolerant and hot insertable reference inputs
- Multiply ratios of (1–6, 8, 10, 12)
- Operation up to 12x input frequency
- Individual output bank disable for aggressive power management and EMI reduction
- Output high impedance option for testing purposes
- Fully integrated PLL with lock indicator
- Low cycle-to-cycle jitter (<100 ps peak-peak)
- Single 3.3 V ± 10% supply
- 44-pin TQFP package

Functional Description

The CY7B9930V and CY7B9940V High-Speed Multi-frequency PLL Clock Buffers offer user-selectable control over system clock functions. This multiple output clock driver provides the system integrator with functions necessary to optimize the timing of high performance computer or communication systems.

Ten configurable outputs can each drive terminated transmission lines with impedances as low as 50 Ω while delivering minimal and specified output skews at LVTTTL levels. The outputs are arranged in three banks. The FB feedback bank consists of two outputs, which allows divide-by functionality from 1 to 12. Any one of these ten outputs can be connected to the feedback input as well as driving other inputs.

Selectable reference input is a fault tolerance feature that allows smooth change over to secondary clock source, when the primary clock source is not in operation. The reference inputs are configurable to accommodate both LVTTTL or differential (LVPECL) inputs. The completely integrated PLL reduces jitter and simplifies board layout.

For a complete list of related documentation, [click here](#).

Logic Block Diagram

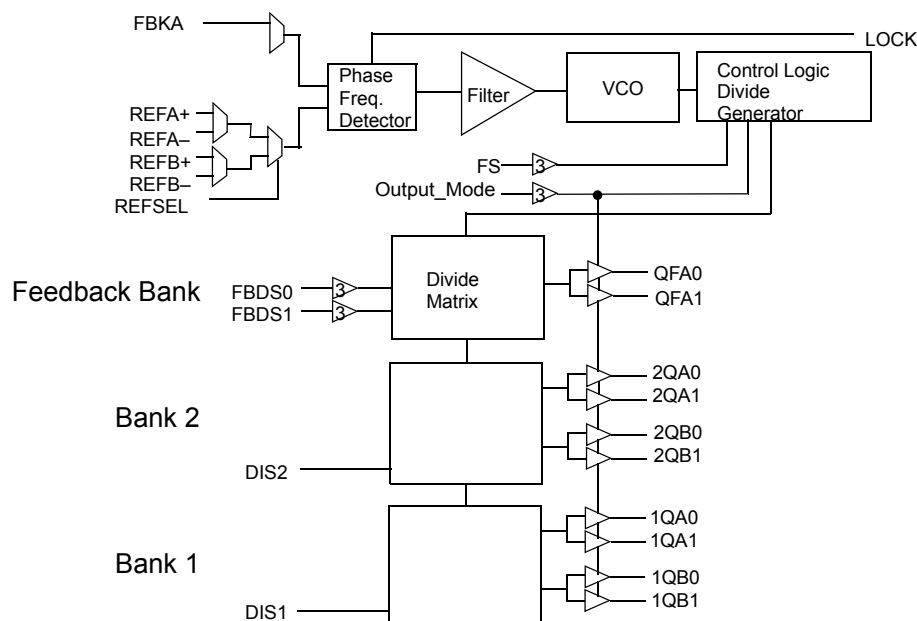

Contents

Logic Block Diagram Description	3	Switching Characteristics	10
Phase Frequency Detector and Filter	3	AC Timing Diagrams	11
VCO, Control Logic, and Divide Generator	3	Ordering Information	12
Divide Matrix	3	Ordering Code Definitions	12
Output Disable Description	3	Package Diagram	13
Lock Detect Output Description	4	Acronyms	13
Factory Test Mode Description	4	Document Conventions	14
Pin Configuration	5	Units of Measure	14
Pin Definitions	6	Document History Page	15
Absolute Maximum Conditions	7	Sales, Solutions, and Legal Information	16
Operating Range	7	Worldwide Sales and Design Support	16
Electrical Characteristics	7	Products	16
Capacitance	9	PSoC@Solutions	16
Thermal Resistance	9	Cypress Developer Community	16
AC Test Loads and Waveforms	9	Technical Support	16

Logic Block Diagram Description

Phase Frequency Detector and Filter

These two blocks accept signals from the REF inputs (REFA+, REFA-, REFB+ or REFB-) and the FB input (FBKA). Correction information is then generated to control the frequency of the Voltage Controlled Oscillator (VCO). These two blocks, along with the VCO, form a Phase-Locked Loop (PLL) that tracks the incoming REF signal.

The RoboClockII™ Junior has a flexible REF input scheme. These inputs allow the use of either differential LVPECL or single ended LVTTTL inputs. To configure as single ended LVTTTL inputs, leave the complementary pin to 1.5V, then use the other input pin as an LVTTTL input. The REF inputs are also tolerant to hot insertion.

The REF inputs can be changed dynamically. When changing from one reference input to the other reference input of the same frequency, the PLL is optimized to ensure that the clock outputs period is not less than the calculated system budget ($t_{MIN} = t_{REF}$ (nominal reference clock period) - t_{CCJ} (cycle-to-cycle jitter) - t_{PDEV} (max. period deviation)) while reacquiring lock.

VCO, Control Logic, and Divide Generator

The VCO accepts analog control inputs from the PLL filter block. The FS control pin setting determines the nominal operational frequency range of the divide by one output (f_{NOM}) of the device. f_{NOM} is directly related to the VCO frequency. There are two versions of the RoboClockII Junior, a low speed device (CY7B9930V) where f_{NOM} ranges from 12 MHz to 100 MHz, and a high speed device (CY7B9940V), which ranges from 24 MHz to 200 MHz. The FS setting for each device is shown in Table 1. The f_{NOM} frequency is seen on “divide-by-one” outputs.

Table 1. Frequency Range Select

FS ^[1]	CY7B9930V		CY7B9940V	
	f_{NOM} (MHz)		f_{NOM} (MHz)	
	Min.	Max.	Min.	Max.
LOW	12	26	24	52
MID	24	52	48	100
HIGH	48	100	96	200 ^[2]

Divide Matrix

The Divide Matrix is comprised of three independent banks: two banks of clock outputs and one bank for feedback. Each clock output bank has two pairs of low-skew, high fanout output buffers ([1:2]Q[A:B][0:1]), and an output disable (DIS[1:2]).

The feedback bank has one pair of low-skew, high fanout output buffers (QFA[0:1]). One of these outputs may connect to the

selected feedback input (FBKA+). This feedback bank also has two divider function selects FBDS[0:1].

The divide capabilities for each bank are shown in Table 2.

Table 2. Output Divider Function

Function Selects		Output Divider Function		
FBDS1	FBDS0	Bank 1	Bank 2	Feedback Bank
LOW	LOW	/1	/1	/1
LOW	MID	/1	/1	/2
LOW	HIGH	/1	/1	/3
MID	LOW	/1	/1	/4
MID	MID	/1	/1	/5
MID	HIGH	/1	/1	/6
HIGH	LOW	/1	/1	/8
HIGH	MID	/1	/1	/10
HIGH	HIGH	/1	/1	/12

Output Disable Description

The outputs of Bank 1 and Bank 2 can be independently put into a HOLD OFF or high impedance state. The combination of the Output_Mode and DIS[1:2] inputs determines the clock outputs' state for each bank. When the DIS[1:2] is LOW, the outputs of the corresponding bank are enabled. When the DIS[1:2] is HIGH, the outputs for that bank are disabled to a high impedance (HI-Z) or HOLD OFF state depending on the Output_Mode input. Table 3 defines the disabled output functions.

The HOLD OFF state is designed as a power saving feature. An output bank is disabled to the HOLD OFF state in a maximum of six output clock cycles from the time when the disable input (DIS[1:2]) is HIGH. When disabled to the HOLD OFF state, outputs are driven to a logic LOW state on its falling edge. This ensures the output clocks are stopped without glitch. When a bank of outputs is disabled to HI-Z state, the respective bank of outputs go HI-Z immediately.

Table 3. DIS[1:2] Pin Functionality

OUTPUT_MODE	DIS[1:2]/FBDIS	Output Mode
HIGH/LOW	LOW	ENABLED
HIGH	HIGH	HI-Z
LOW	HIGH	HOLD-OFF
MID	X	FACTORY TEST

Notes

- The level to be set on FS is determined by the “nominal” operating frequency (f_{NOM}) of the VCO. f_{NOM} always appears on an output when the output is operating in the undivided mode. The REF and FB are at f_{NOM} when the output connected to FB is undivided.
- The maximum output frequency is 200 MHz.

Lock Detect Output Description

The LOCK detect output indicates the lock condition of the integrated PLL. Lock detection is accomplished by comparing the phase difference between the reference and feedback inputs. Phase error is declared when the phase difference between the two inputs is greater than the specified device propagation delay limit (t_{PD}).

When in the locked state, after four or more consecutive feedback clock cycles with phase errors, the LOCK output is forced LOW to indicate out-of-lock state.

When in the out-of-lock state, 32 consecutive phase errorless feedback clock cycles are required to allow the LOCK output to indicate lock condition (LOCK = HIGH).

If the feedback clock is removed after LOCK has gone HIGH, a Watchdog circuit is implemented to indicate the out-of-lock condition after a timeout period by deasserting LOCK LOW. This timeout period is based upon a divided down reference clock.

This assumes that there is activity on the selected REF input. If there is no activity on the selected REF input then the LOCK detect pin may not accurately reflect the state of the internal PLL.

Factory Test Mode Description

The device enters factory test mode when the OUTPUT_MODE is driven to MID. In factory test mode, the device operates with

its internal PLL disconnected; the input level supplied to the reference input is used in place of the PLL output. In TEST mode the selected FB input must be tied LOW. All functions of the device remain operational in factory test mode except the internal PLL and output bank disables. The OUTPUT_MODE input is designed as a static input. Dynamically toggling this input from LOW to HIGH may temporarily cause the device to go into factory test mode (when passing through the MID state).

Factory Test Reset

When in factory test mode (OUTPUT_MODE = MID), the device is reset to a deterministic state by driving the DIS2 input HIGH. When the DIS2 input is driven HIGH in factory test mode, all clock outputs go to HI-Z; after the selected reference clock pin has five positive transitions, all the internal finite state machines (FSM) are set to a deterministic state. The deterministic state of the state machines depends on the configurations of the divide selects and frequency select input. All clock outputs stay in high impedance mode and all FSMs stay in the deterministic state until DIS2 is deasserted. When DIS2 is deasserted (with OUTPUT_MODE still at MID), the device reenters factory test mode.

Pin Configuration

Figure 1. 44-pin TQFP pinout

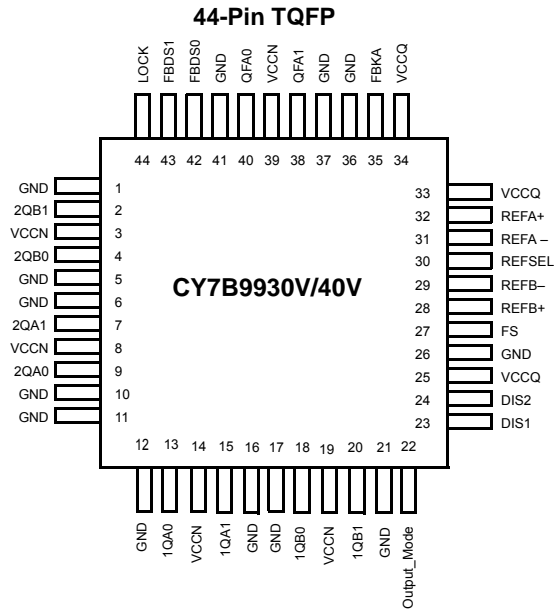

Pin Definitions

Name	I/O	Type	Description
FBKA	Input	LVTTL	Feedback Input.
REFA+, REFA-, REFB+, REFB-	Input	LVTTL/ LVDIFF	Reference Inputs: These inputs operate as either differential PECL or single ended TTL reference inputs to the PLL. When operating as a single ended LVTTL input, leave the complementary input must be left open.
REFSEL	Input	LVTTL	Reference Select Input: The REFSEL input controls reference input configuration. When LOW, it uses the REFA pair as the reference input. When HIGH, it uses the REFB pair as the reference input. This input has an internal pull down.
FS ^[3]	Input	3 Level Input	Frequency Select: Set this input according to the nominal frequency (f_{NOM}). See Table 1 .
FBDS[0:1] ^[3]	Input	3 Level Input	Feedback Divider Function Select. These inputs determine the function of the QFA0 and QFA1 outputs. See Table 2 .
DIS[1:2]	Input	LVTTL	Output Disable: Each input controls the state of the respective output bank. When HIGH, the output bank is disabled to the “HOLD OFF” or “HI-Z” state; the disable state is determined by OUTPUT_MODE. When LOW, the [1:4]Q[A:B][0:1] is enabled. See Table 3 . These inputs each have an internal pull down.
LOCK	Output	LVTTL	PLL Lock Indicator: When HIGH, this output indicates that the internal PLL is locked to the reference signal. When LOW, the PLL is attempting to acquire lock.
Output_Mode ^[3]	Input	3 Level Input	Output Mode: This pin determines the clock outputs’ disable state. When this input is HIGH, the clock outputs disable to high impedance (HI-Z). When this input is LOW, the clock outputs disables to “HOLD OFF” mode. When in MID, the device enters factory test mode.
QFA[0:1]	Output	LVTTL	Clock Feedback Output: This pair of clock outputs connects to the FB input. These outputs have numerous divide options. The function is determined by the setting of the FBDS[0:1] pins.
[1:2]Q[A:B][0:1]	Output	LVTTL	Clock Output.
VCCN		PWR	Output Buffer Power: Power supply for each output pair.
VCCQ		PWR	Internal Power: Power supply for the internal circuitry.
GND		PWR	Device Ground.

Note

3. For all tri-state inputs, HIGH indicates a connection to V_{CC} , LOW indicates a connection to GND, and MID indicates an open connection. Internal termination circuitry holds an unconnected input to $V_{CC}/2$.

Absolute Maximum Conditions

Exceeding the maximum ratings may impair the useful life of the device. These user guidelines are not tested.

Storage temperature -40 °C to +125 °C
 Ambient temperature with power applied -40 °C to +125 °C
 Supply voltage to ground potential -0.5V to +4.6V
 DC input voltage -0.3V to $V_{CC}+0.5V$
 Output current into outputs (LOW) 40 mA

Static discharge voltage
 (MIL-STD-883, Method 3015) >2000 V

Latch up current >±200 mA

Operating Range

Range	Ambient Temperature	V_{CC}
Commercial	0 °C to +70 °C	3.3 V ±10%
Industrial	-40 °C to +85 °C	3.3 V ±10%

Electrical Characteristics

Over the Operating Range

Parameter	Description	Test Conditions	Min	Max	Unit	
LVTTTL Compatible Output Pins (QFA[0:1], [1:4]Q[A:B][0:1], LOCK)						
V_{OH}	LVTTTL HIGH voltage	QFA[0:1], [1:2]Q[A:B][0:1]	$V_{CC} = \text{Min.}, I_{OH} = -30 \text{ mA}$	2.4	-	V
		LOCK	$I_{OH} = -2 \text{ mA}, V_{CC} = \text{Min.}$	2.4	-	V
V_{OL}	LVTTTL LOW voltage	QFA[0:1], [1:2]Q[A:B][0:1]	$V_{CC} = \text{Min.}, I_{OL} = 30 \text{ mA}$	-	0.5	V
		LOCK	$I_{OL} = 2 \text{ mA}, V_{CC} = \text{Min.}$	-	0.5	V
I_{OZ}	High impedance state leakage current		-100	100	μA	
LVTTTL Compatible Input Pins (FBKA, REFA±, REFB±, REFSEL, DIS[1:2])						
V_{IH}	LVTTTL Input HIGH	FBKA+, REF[A:B]±	$\text{Min.} \leq V_{CC} \leq \text{Max.}$	2.0	$V_{CC} + 0.3$	V
		REFSEL, DIS[1:2]		2.0	$V_{CC} + 0.3$	V
V_{IL}	LVTTTL Input LOW	FBKA+, REF[A:B]±	$\text{Min.} \leq V_{CC} \leq \text{Max.}$	-0.3	0.8	V
		REFSEL, DIS[1:2]		-0.3	0.8	V
I_I	LVTTTL $V_{IN} > V_{CC}$	FBKA+, REF[A:B]±	$V_{CC} = \text{GND}, V_{IN} = 3.63\text{V}$	-	100	μA
I_{IH}	LVTTTL Input HIGH Current	FBKA+, REF[A:B]±	$V_{CC} = \text{Max.}, V_{IN} = V_{CC}$	-	500	μA
		REFSEL, DIS[1:2]	$V_{IN} = V_{CC}$	-	500	μA
I_{IL}	LVTTTL Input LOW Current	FBKA+, REF[A:B]±	$V_{CC} = \text{Max.}, V_{IN} = \text{GND}$	-500	-	μA
		REFSEL, DIS[1:2]		-500	-	μA
3-Level Input Pins (FBDS[0:1], FS, Output_Mode)						
V_{IHH}	Three level input HIGH ^[4]		$\text{Min.} \leq V_{CC} \leq \text{Max.}$	$0.87 \times V_{CC}$	-	V
V_{IMM}	Three level input MID ^[4]		$\text{Min.} \leq V_{CC} \leq \text{Max.}$	$0.47 \times V_{CC}$	$0.53 \times V_{CC}$	V
V_{ILL}	Three level input LOW ^[4]		$\text{Min.} \leq V_{CC} \leq \text{Max.}$	-	$0.13 \times V_{CC}$	V
I_{IHH}	Three level input HIGH current	Three level input pins	$V_{IN} = V_{CC}$	-	200	μA
I_{IMM}	Three level input MID current	Three level input pins	$V_{IN} = V_{CC}/2$	-50	50	μA
I_{ILL}	Three level input LOW current	Three level input pins	$V_{IN} = \text{GND}$	-200	-	μA

Note

4. These inputs are normally wired to V_{CC} , GND, or left unconnected (actual threshold voltages vary as a percentage of V_{CC}). Internal termination resistors hold the unconnected inputs at $V_{CC}/2$. If these inputs are switched, the function and timing of the outputs may glitch and the PLL may require an additional t_{LOCK} time before all data sheet limits are achieved.

Electrical Characteristics (continued)

Over the Operating Range

Parameter	Description	Test Conditions	Min	Max	Unit	
LVDIFF Input Pins (REF[A:B]±)						
V _{DIFF}	Input differential voltage		400	V _{CC}	mV	
V _{IHHP}	Highest input HIGH voltage		1.0	V _{CC}	V	
V _{ILLP}	Lowest input LOW voltage		GND	V _{CC} - 0.4	V	
V _{COM}	Common mode range (crossing voltage)		0.8	V _{CC}	V	
Operating Current						
I _{CCI}	Internal operating current	CY7B9930V	V _{CC} = Max., f _{MAX} ^[5]	-	200	mA
		CY7B9940V		-	200	mA
I _{CCN}	Output current dissipation/pair ^[6]	CY7B9930V	V _{CC} = Max., C _{LOAD} = 25 pF, R _{LOAD} = 50Ω at V _{CC} /2, f _{MAX}	-	40	mA
		CY7B9940V		-	50	mA

Notes

- I_{CCI} measurement is performed with Bank1 and FB Bank configured to run at maximum frequency (f_{NOM} = 100 MHz for CY7B9930V, f_{NOM} = 200 MHz for CY7B9940V), and all other clock output banks to run at half the maximum frequency. FS and OUTPUT_MODE are asserted to the HIGH state.
- This is dependent upon frequency and number of outputs of a bank being loaded. The value indicates maximum I_{CCN} at maximum frequency and maximum load of 25 pF terminated to 50Ω at V_{CC}/2.

Capacitance

Parameter	Description	Test Conditions	Min.	Max.	Unit
C _{IN}	Input capacitance	T _A = 25 °C, f = 1 MHz, V _{CC} = 3.3 V	–	5	pF

Thermal Resistance

Parameter ^[7]	Description	Test Conditions	44-pin TQFP	Unit
θ _{JA}	Thermal resistance (junction to ambient)	Test conditions follow standard test methods and procedures for measuring thermal impedance, in accordance with EIA/JESD51.	50	°C/W
θ _{JC}	Thermal resistance (junction to case)		15	°C/W

AC Test Loads and Waveforms

Figure 2. AC Test Loads and Waveforms ^[8]

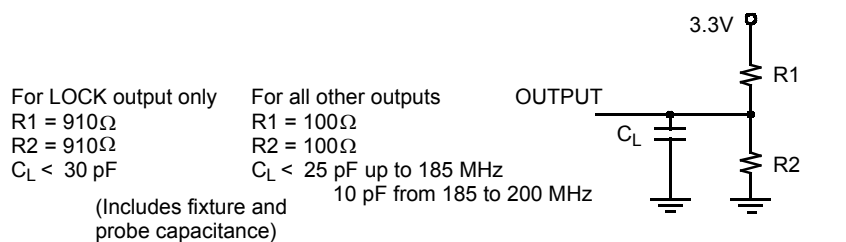

(a) LVTTL AC Test Load

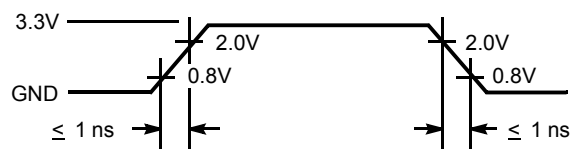

(b) TTL Input Test Waveform

Notes

7. These parameters are guaranteed by design and are not tested.
8. These figures are for illustration only. The actual ATE loads may vary.

Switching Characteristics

Over the Operating Range [9, 10, 11, 12, 13]

Parameter	Description	CY7B9930/40V-2		CY7B9930/40V-5		Unit	
		Min.	Max.	Min.	Max.		
f _{in}	Clock input frequency	CY7B9930V	12	100	12	100	MHz
		CY7B9940V	24	200	24	200	MHz
f _{out}	Clock input frequency	CY7B9930V	12	100	12	100	MHz
		CY7B9940V	24	200	24	200	MHz
t _{SKEWPR}	Matched pair skew [14, 15]	–	185	–	185	ps	
t _{SKEWBNK}	Intrabank skew [14, 15]	–	200	–	250	ps	
t _{SKEW0}	Output-Output skew (same frequency and phase, rise to rise, fall to fall) [14, 15]	–	250	–	550	ps	
t _{SKEW1}	Output-Output skew (same frequency and phase, other banks at different frequency, rise to rise, fall to fall) [14, 15]	–	250	–	650	ps	
t _{CCJ1-3}	Cycle-to-cycle jitter (divide by 1 output frequency, FB = divide by 1, 2, 3)	–	150	–	150	ps Peak-Peak	
t _{CCJ4-12}	Cycle-to-cycle jitter (divide by 1 output frequency, FB = divide by 4, 5, 6, 8, 10, 12)	–	100	–	100	ps Peak-Peak	
t _{PD}	Propagation delay, REF to FB Rise	–250	250	–500	500	ps	
t _{PDELTA}	Propagation delay difference between two devices [16]	–	200	–	200	ps	
t _{REFpwh}	REF input (pulse width HIGH) [17]	2.0	–	2.0	–	ns	
t _{REFpwl}	REF input (pulse width LOW) [17]	2.0	–	2.0	–	ns	
t _r /t _f	Output rise/fall time [18]	0.15	2.0	0.15	2.0	ns	
t _{LOCK}	PLL lock time from power-up	–	10	–	10	ms	
t _{RELOCK1}	PLL relock time (from same frequency, different phase) with stable power supply	–	500	–	500	μs	
t _{RELOCK2}	PLL Relock Time (from different frequency, different phase) with Stable Power Supply [19]	–	1000	–	1000	μs	
t _{ODCV}	Output duty cycle deviation from 50% [13]	–1.0	1.0	–1.0	1.0	ns	
t _{PWH}	Output HIGH time deviation from 50% [20]	–	1.5	–	1.5	ns	
t _{PWL}	Output LOW time deviation from 50% [20]	–	2.0	–	2.0	ns	
t _{PDEV}	Period deviation when changing from reference to reference [21]	–	0.025	–	0.025	UI	
t _{OAZ}	DIS[1:2] HIGH to output high impedance from ACTIVE [14, 22]	1.0	10	1.0	10	ns	
t _{OZA}	DIS[1:2] LOW to output ACTIVE from output is high impedance [22, 23]	0.5	14	0.5	14	ns	

Notes

9. This is for non-three level inputs.
10. Assumes 25 pF Max. Load Capacitance up to 185 Mhz. At 200 MHz the max load is 10 pF.
11. Both outputs of pair must be terminated, even if only one is being used.
12. Each package must be properly decoupled.
13. AC parameters are measured at 1.5V, unless otherwise indicated.
14. Test Load C_L = 25 pF, terminated to V_{CC}/2 with 50Ω.
15. SKEW is defined as the time between the earliest and the latest output transition among all outputs for which the same phase delay has been selected when all outputs are loaded with 25 pF and properly terminated up to 185 MHz. At 200 MHz the max load is 10 pF.
16. Guaranteed by statistical correlation. Tested initially and after any design or process changes that may affect these parameters.
17. Tested initially and after any design or process changes that may affect these parameters.
18. Rise and fall times are measured between 2.0V and 0.8V.
19. f_{NOM} must be within the frequency range defined by the same FS state.
20. t_{PWH} is measured at 2.0V. t_{PWL} is measured at 0.8V.
21. UI = Unit Interval. Examples: 1 UI is a full period. 0.1 UI is 10% of period.
22. Measured at 0.5V deviation from starting voltage.
23. For t_{OZA} minimum, C_L = 0 pF. For t_{OZA} maximum, C_L = 25 pF to 18 MHz, 10 pF from 185 to 200 MHz.

AC Timing Diagrams

Figure 3. AC Timing Diagrams [24]

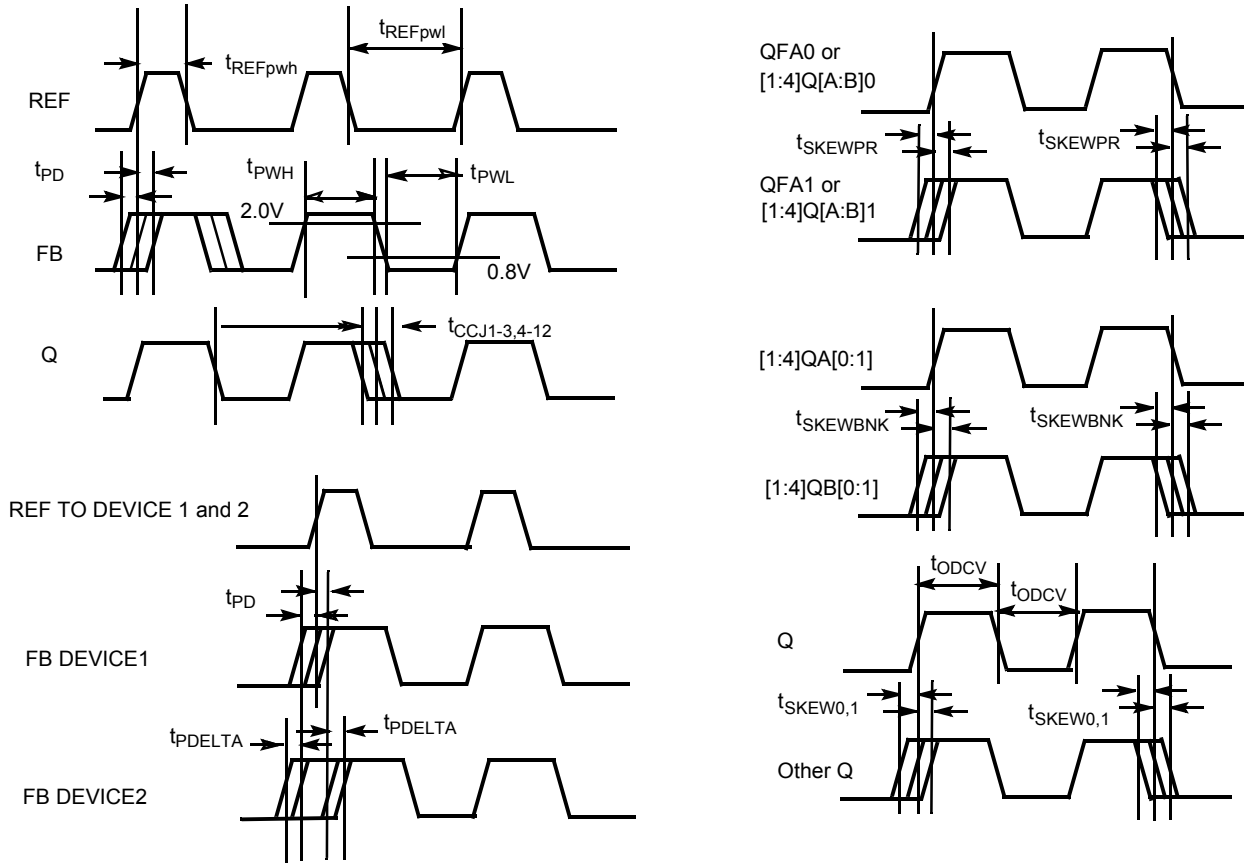

Note
24. AC parameters are measured at 1.5 V, unless otherwise indicated.

Ordering Information

Propagation Delay (ps)	Max Speed (MHz)	Ordering Code	Package Type	Operating Range
Pb-free				
500	100	CY7B9930V-5AXC	44-pin TQFP	Commercial
500	100	CY7B9930V-5AXCT	44-pin TQFP – Tape and Reel	Commercial
500	200	CY7B9940V-5AXC	44-pin TQFP	Commercial
500	200	CY7B9940V-5AXCT	44-pin TQFP – Tape and Reel	
250	200	CY7B9940V-2AXC	44-pin TQFP	Commercial
250	200	CY7B9940V-2AXCT	44-pin TQFP – Tape and Reel	

Ordering Code Definitions

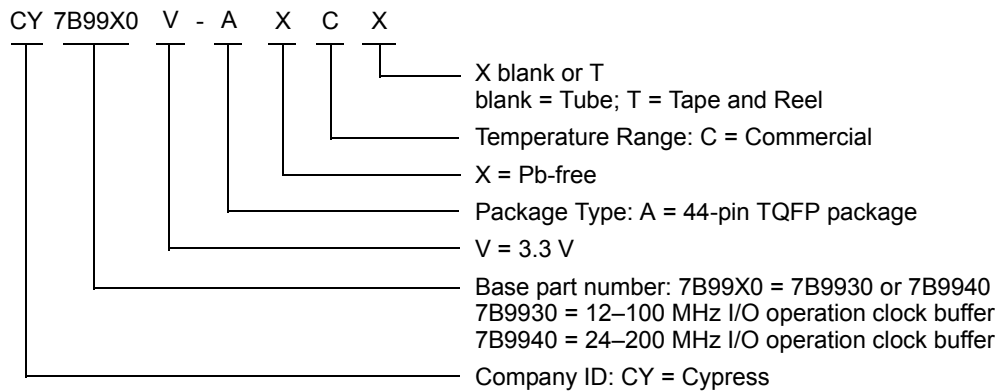

Package Diagram

Figure 4. 44-pin TQFP (10 × 10 × 1.4 mm) A44S Package Outline, 51-85064

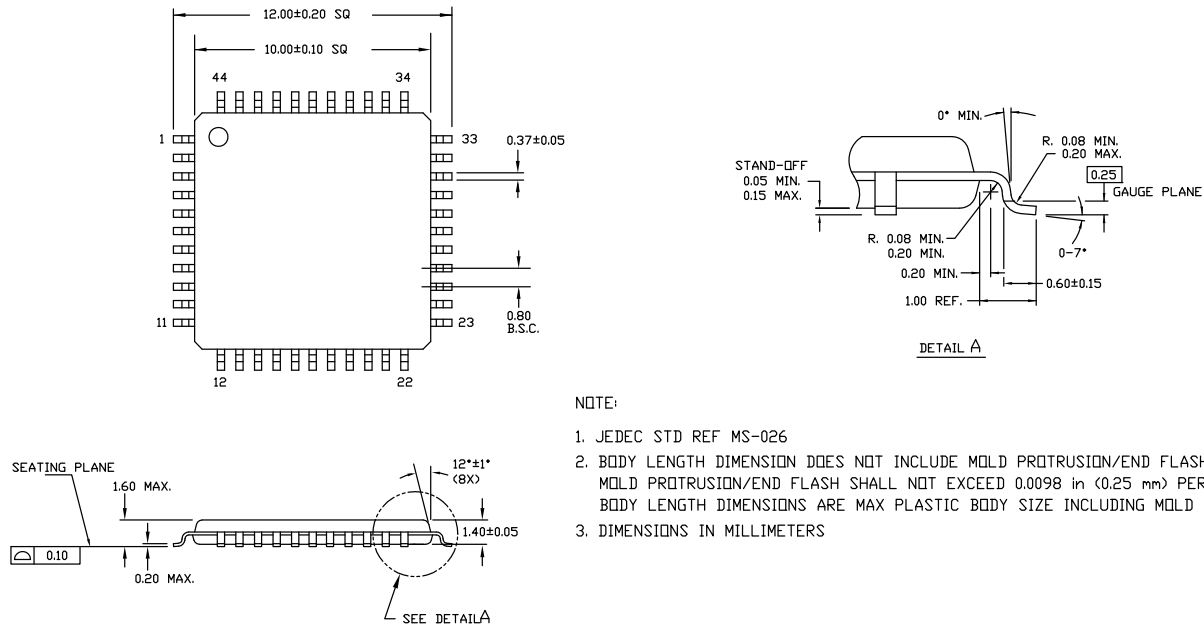

NOTE:

1. JEDEC STD REF MS-026
2. BODY LENGTH DIMENSION DOES NOT INCLUDE MOLD PROTRUSION/END FLASH
 MOLD PROTRUSION/END FLASH SHALL NOT EXCEED 0.0098 in (0.25 mm) PER SIDE
 BODY LENGTH DIMENSIONS ARE MAX PLASTIC BODY SIZE INCLUDING MOLD MISMATCH
3. DIMENSIONS IN MILLIMETERS

51-85064 *G

Acronyms

Acronym	Description
EMI	Electromagnetic Interference
LVPECL	Low-Voltage Positive-Referenced Emitter Coupled Logic
LVTTTL	Low Voltage Transistor-Transistor Logic
PLL	Phase-Locked Loop
TQFP	Thin Quad Flat Pack
VCO	Voltage Controlled Oscillator

Document Conventions

Units of Measure

Symbol	Unit of Measure
°C	degree Celsius
MHz	megahertz
μA	microampere
mA	milliampere
ms	millisecond
mV	millivolt
ns	nanosecond
Ω	ohm
%	percent
pF	picofarad
ps	picosecond
V	volt

Document History Page

Document Title: CY7B9930V/CY7B9940V RoboClock II™ Junior, High-Speed Multi-frequency PLL Clock Buffer Document Number: 38-07271				
Rev.	ECN No.	Submission Date	Orig. of Change	Description of Change
**	110536	12/02/01	SZV	Change from Spec number: 38-01141
*A	115109	7/03/02	HWT	Updated Ordering Information (Updated part numbers).
*B	128463	7/29/03	RGL	Updated Switching Characteristics : Added f_{in} parameter and its details. Added minimum values for f_{out} parameter.
*C	1346903	8/8/07	WWZ / VED / ARI	Updated Ordering Information : Updated part numbers. Updated Package Diagram . Updated to new template.
*D	2894960	03/18/2010	KVM	Added Contents . Updated Ordering Information : Removed part numbers CY7B9930V-5AC, CY7B9930V-5AI, CY7B9940V-5AC, CY7B9940V-5AI, CY7B9930V-2AC, CY7B9930V-2AI and CY7B9940V-2AI. Updated Package Diagram . Added Sales, Solutions, and Legal Information .
*E	2906750	04/07/2010	KVM	Updated Ordering Information : Removed inactive parts.
*F	3053421	10/08/2010	CXQ	Updated Ordering Information : Removed inactive parts CY7B9940V-2AXI, CY7B9940V-2AXIT. Added Ordering Code Definitions .
*G	3859773	01/07/2013	AJU	Updated Ordering Information (Updated part numbers). Updated Package Diagram : spec 51-85064 – Changed revision from *D to *E.
*H	4177300	10/29/2013	CINM	Added Acronyms and Units of Measure . Updated to new template. Completing Sunset Review.
*I	4570131	11/14/2014	CINM	Updated Functional Description : Added “For a complete list of related documentation, click here .” at the end. Updated Package Diagram : spec 51-85064 – Changed revision from *E to *F.
*J	5256972	05/03/2016	PSR	Added Thermal Resistance . Updated Package Diagram : spec 51-85064 – Changed revision from *F to *G. Updated to new template.
*K	5521868	11/15/2016	TAVA	Updated to new template. Completing Sunset Review.

Sales, Solutions, and Legal Information

Worldwide Sales and Design Support

Cypress maintains a worldwide network of offices, solution centers, manufacturer's representatives, and distributors. To find the office closest to you, visit us at [Cypress Locations](#).

Products

ARM® Cortex® Microcontrollers	cypress.com/arm
Automotive	cypress.com/automotive
Clocks & Buffers	cypress.com/clocks
Interface	cypress.com/interface
Internet of Things	cypress.com/iot
Lighting & Power Control	cypress.com/powerpsoc
Memory	cypress.com/memory
PSoC	cypress.com/psoc
Touch Sensing	cypress.com/touch
USB Controllers	cypress.com/usb
Wireless/RF	cypress.com/wireless

PSoC® Solutions

[PSoC 1](#) | [PSoC 3](#) | [PSoC 4](#) | [PSoC 5LP](#)

Cypress Developer Community

[Forums](#) | [Projects](#) | [Video](#) | [Blogs](#) | [Training](#) | [Components](#)

Technical Support

cypress.com/support

© Cypress Semiconductor Corporation, 2001-2016. This document is the property of Cypress Semiconductor Corporation and its subsidiaries, including Spansion LLC ("Cypress"). This document, including any software or firmware included or referenced in this document ("Software"), is owned by Cypress under the intellectual property laws and treaties of the United States and other countries worldwide. Cypress reserves all rights under such laws and treaties and does not, except as specifically stated in this paragraph, grant any license under its patents, copyrights, trademarks, or other intellectual property rights. If the Software is not accompanied by a license agreement and you do not otherwise have a written agreement with Cypress governing the use of the Software, then Cypress hereby grants you a personal, non-exclusive, nontransferable license (without the right to sublicense) (1) under its copyright rights in the Software (a) for Software provided in source code form, to modify and reproduce the Software solely for use with Cypress hardware products, only internally within your organization, and (b) to distribute the Software in binary code form externally to end users (either directly or indirectly through resellers and distributors), solely for use on Cypress hardware product units, and (2) under those claims of Cypress's patents that are infringed by the Software (as provided by Cypress, unmodified) to make, use, distribute, and import the Software solely for use with Cypress hardware products. Any other use, reproduction, modification, translation, or compilation of the Software is prohibited.

TO THE EXTENT PERMITTED BY APPLICABLE LAW, CYPRESS MAKES NO WARRANTY OF ANY KIND, EXPRESS OR IMPLIED, WITH REGARD TO THIS DOCUMENT OR ANY SOFTWARE OR ACCOMPANYING HARDWARE, INCLUDING, BUT NOT LIMITED TO, THE IMPLIED WARRANTIES OF MERCHANTABILITY AND FITNESS FOR A PARTICULAR PURPOSE. To the extent permitted by applicable law, Cypress reserves the right to make changes to this document without further notice. Cypress does not assume any liability arising out of the application or use of any product or circuit described in this document. Any information provided in this document, including any sample design information or programming code, is provided only for reference purposes. It is the responsibility of the user of this document to properly design, program, and test the functionality and safety of any application made of this information and any resulting product. Cypress products are not designed, intended, or authorized for use as critical components in systems designed or intended for the operation of weapons, weapons systems, nuclear installations, life-support devices or systems, other medical devices or systems (including resuscitation equipment and surgical implants), pollution control or hazardous substances management, or other uses where the failure of the device or system could cause personal injury, death, or property damage ("Unintended Uses"). A critical component is any component of a device or system whose failure to perform can be reasonably expected to cause the failure of the device or system, or to affect its safety or effectiveness. Cypress is not liable, in whole or in part, and you shall and hereby do release Cypress from any claim, damage, or other liability arising from or related to all Unintended Uses of Cypress products. You shall indemnify and hold Cypress harmless from and against all claims, costs, damages, and other liabilities, including claims for personal injury or death, arising from or related to any Unintended Uses of Cypress products.

Cypress, the Cypress logo, Spansion, the Spansion logo, and combinations thereof, PSoC, CapSense, EZ-USB, F-RAM, and Traveo are trademarks or registered trademarks of Cypress in the United States and other countries. For a more complete list of Cypress trademarks, visit cypress.com. Other names and brands may be claimed as property of their respective owners.

Looking for pricing, stock, or lifecycle information?

Click below to explore more details on WIN SOURCE:

 [View CY7B9940V-2AXC on WIN SOURCE](#)

 [Cypress Semiconductor Corp](#) Information

Optimize Your Supply Chain with WIN SOURCE Solutions

-  Global Sourcing Solution
-  Obsolete Management
-  Cost Control Management
-  Shortage Management
-  Alternative Solution
-  Excess Inventory Management