



THE DATASHEET OF
MJ11033





ELECTRONICS, INC.
 44 FARRAND STREET
 BLOOMFIELD, NJ 07003
 (973) 748-5089
<http://www.nteinc.com>

MJ11032 (NPN) & MJ11033 (PNP) Silicon Darlington Transistors High Current, General Purpose TO-3 Type Package

Description:

The MJ11032 (NPN) and MJ11033 (PNP) are silicon complementary Darlington transistors in a TO-3 type package designed for use as output devices in general purpose amplifier applications.

Features:

- High Gain Darlington Performance
- High DC Current Gain: $h_{FE} = 1000$ (Min) @ $I_C = 25A$
 $h_{FE} = 400$ (Min) @ $I_C = 50A$
- Monolithic Construction ^w/Built-In Base-Emitter Shunt Resistor

Absolute Maximum Ratings:

Collector-Emitter Voltage, V_{CEO}	120V
Collector-Base Voltage, V_{CB}	120V
Emitter-Base Voltage, V_{EBO}	5V
Collector Current, I_C	
Continuous	50A
Peak	100A
Continuous Base Current, I_B	2A
Total Power Dissipation ($T_C = +25^\circ C$), P_D	300W
Derate Above $25^\circ C$ @ $T_C = +100^\circ C$	1.71W/ $^\circ C$
Operating Junction Temperature Range, T_J	-65° to $+200^\circ C$
Storage Temperature Range, T_{stg}	-65° to $+200^\circ C$
Thermal Resistance, Junction-to-Case, R_{thJC}	0.584 $^\circ C/W$

Electrical Characteristics: ($T_C = +25^\circ C$ unless otherwise specified)

Parameter	Symbol	Test Conditions	Min	Typ	Max	Unit
OFF Characteristics						
Collector-Emitter Sustaining Voltage	$V_{CEO(sus)}$	$I_C = 100mA, I_B = 0$, Note 1	120	-	-	V
Collector Cutoff Current	I_{CEO}	$V_{CE} = 50V, I_B = 0$	-	-	2	mA
Collector-Emitter Leakage Current	I_{CER}	$V_{CE} = 120V, R_{BE} = 1k\Omega$	-	-	2	mA
		$V_{CE} = 120V, R_{BE} = 1k\Omega, T_C = +125^\circ C$	-	-	10	mA
Emitter Cutoff Current	I_{EBO}	$V_{BE} = 5V, I_C = 0$	-	-	5	mA

Note 1. Pulse Test: Pulse Width = 300 μs , Duty Cycle $\leq 2\%$.

Electrical Characteristics (Cont'd): ($T_C = +25^\circ\text{C}$ unless otherwise specified)

Parameter	Symbol	Test Conditions	Min	Typ	Max	Unit
ON Characteristics (Note 1)						
DC Current Gain	h_{FE}	$I_C = 25\text{A}, V_{CE} = 5\text{V}$	1000	-	18000	
		$I_C = 50\text{A}, V_{CE} = 5\text{V}$	400	-	-	
Collector-Emitter Saturation Voltage	$V_{CE(sat)}$	$I_C = 25\text{A}, I_B = 250\text{mA}$	-	-	2.5	V
		$I_C = 50\text{A}, I_B = 500\text{mA}$	-	-	3.5	V
Base-Emitter Saturation Voltage	$V_{BE(sat)}$	$I_C = 25\text{A}, I_B = 200\text{mA}$	-	-	3.0	V
		$I_C = 50\text{A}, I_B = 300\text{mA}$	-	-	4.5	V
Dynamic Characteristics						
Small-Signal Current Gain	$ h_{fe} $	$I_C = 10\text{A}, V_{CE} = 3\text{V}, f = 1.0\text{MHz}$	4	-	-	

Note 1. Pulse Test: Pulse Width = $300\mu\text{s}$, Duty Cycle $\leq 2\%$.

Note 2. $f_T = |h_{fe}| \cdot f_{test}$

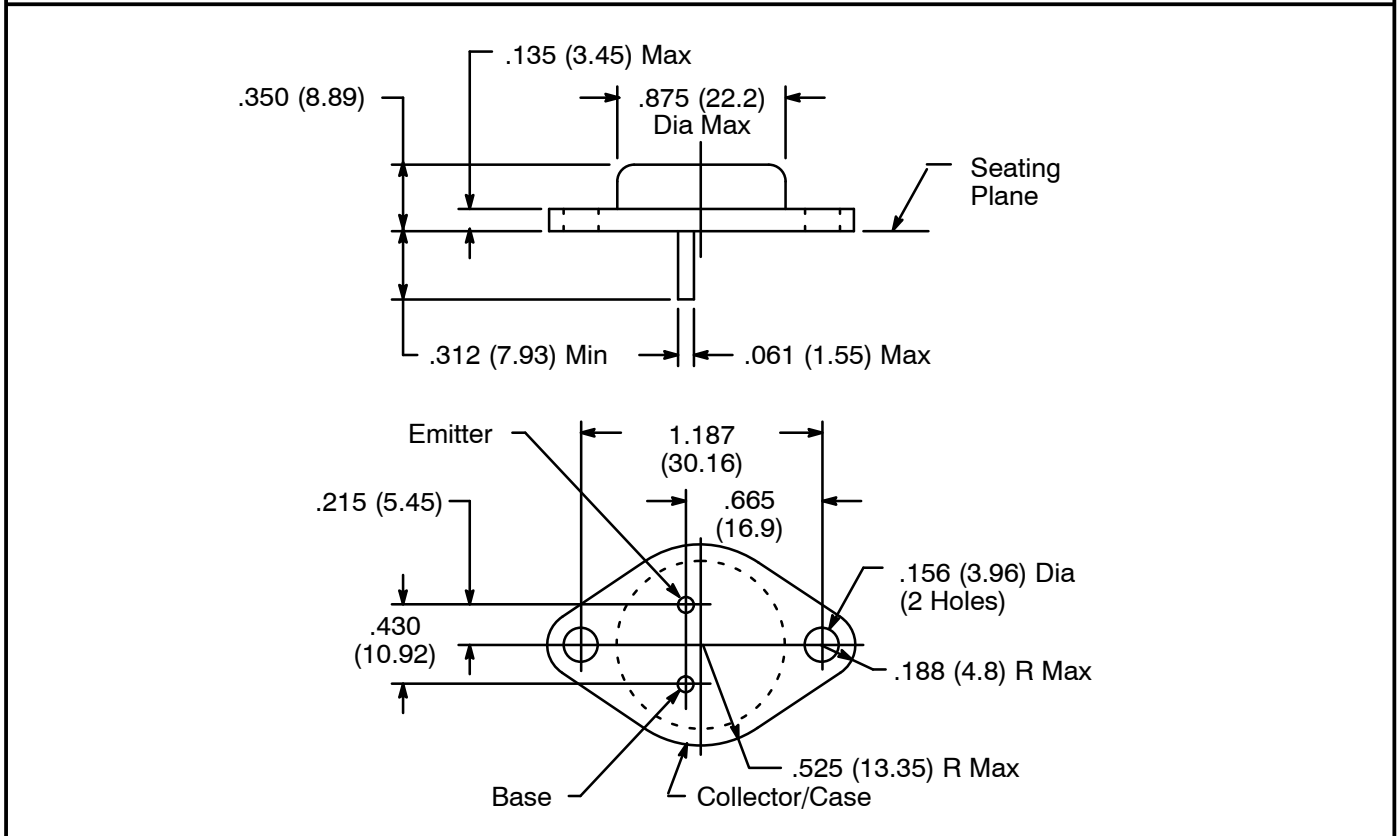
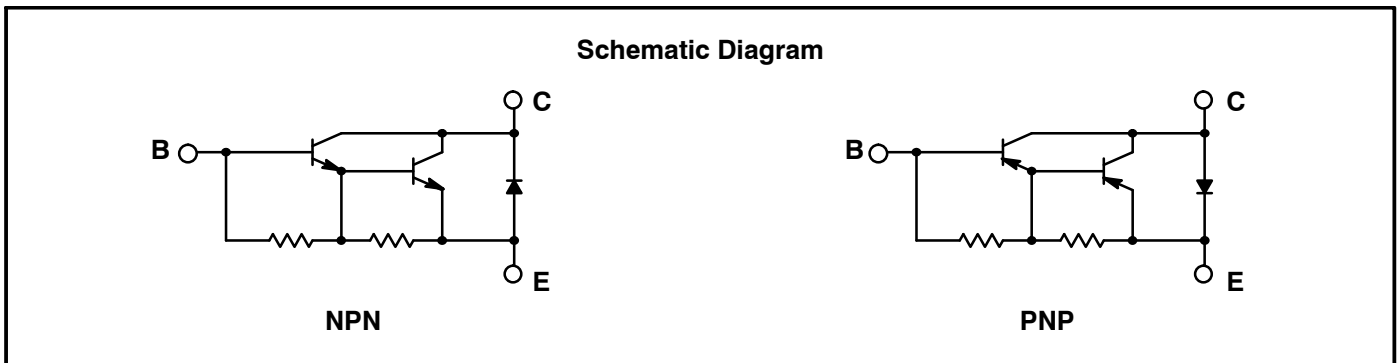

Looking for pricing, stock, or lifecycle information?

Click below to explore more details on WIN SOURCE:

 [View MJ11033 on WIN SOURCE](#)

 [NTE Information](#)

Optimize Your Supply Chain with WIN SOURCE Solutions

-  Global Sourcing Solution
-  Obsolete Management
-  Cost Control Management
-  Shortage Management
-  Alternative Solution
-  Excess Inventory Management