



**THE DATASHEET OF
CY22050KFZXI**



One-PLL General-Purpose Flash-Programmable Clock Generator

Features

- Integrated phase-locked loop (PLL)
- Commercial and Industrial operation
- Flash-programmable
- Field-programmable
- Low-skew, low-jitter, high-accuracy outputs
- 3.3 V operation with 2.5 V output option
- 16-pin TSSOP package (CY22050)
- Input frequency range:
 - 8 MHz–30 MHz (external crystal)
 - 1 MHz–133 MHz (driven clock)
- Output frequency range:
 - Commercial temperature
 - 8 kHz–200 MHz (3.3 V)
 - 8 kHz–166.6 MHz (2.5 V)
 - Industrial temperature
 - 8 kHz–166.6 MHz (3.3 V)
 - 8 kHz–150 MHz (2.5 V)

Functional Description

The CY22050 is programmable clock generator for use in networking, telecommunication, datacom, and other general-purpose applications. The CY22050 offers up to six configurable outputs in a 16-pin TSSOP, running off a 3.3 V power supply. The on-chip reference oscillator is designed to run off an 8–30-MHz crystal, or a 1–133-MHz external clock signal.

The CY22050 has a single PLL driving 6 programmable output clocks. The output clocks are derived from the PLL or the reference frequency (REF). Output post dividers are available for either. Four of the outputs can be set as 3.3 V or 2.5 V, for use in a wide variety of portable and low-power applications.

For a complete list of related documentation, click [here](#).

Logic Block Diagram

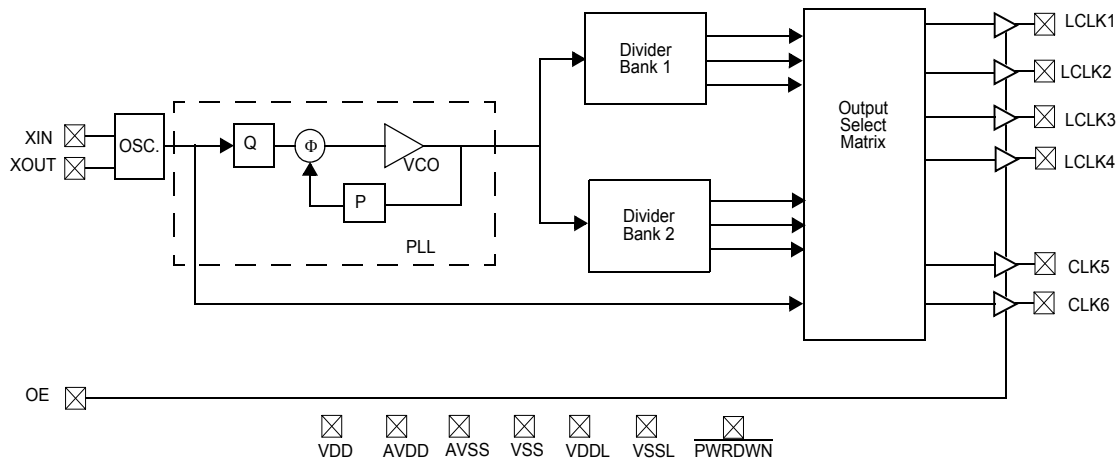

Contents

Pin Configuration	3	Test Circuit	9
Pin Definitions	3	Switching Waveforms	9
Programming Description	4	Ordering Information	10
Field Programming the CY22050F	4	Possible Configurations	10
CyberClocks™ Software	4	Ordering Code Definitions	10
CY3672 Development Kit	4	16-pin TSSOP Package Characteristics	11
Applications	4	Package Drawing and Dimensions	11
Controlling Jitter	4	Acronyms	12
CY22050 Frequency Calculation	5	Document Conventions	12
Clock Output Settings: Crosspoint Switch Matrix	5	Units of Measure	12
Reference Crystal Input	6	Document History Page	13
Crystal Drive Level and Power	6	Sales, Solutions, and Legal Information	15
Absolute Maximum Conditions	6	Worldwide Sales and Design Support	15
Recommended Operating Conditions	7	Products	15
Recommended Crystal Specifications	7	PSoC® Solutions	15
DC Electrical Characteristics	8	Cypress Developer Community	15
AC Electrical Characteristics	8	Technical Support	15

Pin Configuration

Figure 1. 16-pin TSSOP pinout

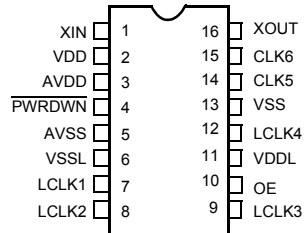

Pin Definitions

Name	Pin Number	Description
XIN	1	Reference Input. Driven by a crystal (8 MHz–30 MHz) or external clock (1 MHz–133 MHz). Programmable input load capacitors allow for maximum flexibility in selecting a crystal, based on manufacturer, process, performance, or quality.
VDD	2	3.3 V voltage supply
AVDD	3	3.3 V analog voltage supply
PWRDWN ^[1]	4	Power Down. When pin 4 is driven LOW, the CY22050 goes into shut down mode.
AVSS	5	Analog ground
VSSL	6	LCLK ground
LCLK1	7	Configurable clock output 1 at V _{DDL} level (3.3 V or 2.5 V)
LCLK2	8	Configurable clock output 2 at V _{DDL} level (3.3 V or 2.5 V)
LCLK3	9	Configurable clock output 3 at V _{DDL} level (3.3 V or 2.5 V)
OE ^[1]	10	Output Enable. When pin 10 is driven LOW, all outputs are three-stated.
VDDL	11	LCLK voltage supply (2.5 V or 3.3 V)
LCLK4	12	Configurable clock output 4 at V _{DDL} level (3.3 V or 2.5 V)
VSS	13	Ground
CLK5	14	Configurable clock output 5 (3.3 V)
CLK6	15	Configurable clock output 6 (3.3 V)
XOUT ^[2]	16	Reference output

Notes

1. The CY22050 has no internal pull up or pull down resistors. PWRDWN and OE pins need to be driven as appropriate or tied to power or ground.
2. Float XOUT if XIN is driven by an external clock source.

Programming Description

Field Programming the CY22050F

The CY22050 is programmed at the package level, that is, in a programmer socket, prior to installation on a PCB. The CY22050 is flash-technology based, so the parts can be reprogrammed up to 100 times. This allows for fast and easy design changes and product updates, and eliminates any issues with old and out-of-date inventory.

Samples and small prototype quantities can be programmed on the CY3672 programmer. Cypress's value-added distribution partners and third-party programming systems from BP Microsystems, HiLo Systems, and others are available for large-production quantities.

CyberClocks™ Software

CyberClocks is an easy-to-use software application that allows the user to custom-configure the CY22050. Within CyberClocks, select the CyClocksRT™ tool. Users can specify the REF, PLL frequency, output frequencies and/or post-dividers, and different functional options. CyClocksRT outputs an industry-standard JEDEC file used for programming the CY22050.

CyClocksRT can be downloaded free of charge from the Cypress website at <http://www.cypress.com>. Install and run it on any PC running the Windows operating system.

CY3672 Development Kit

The Cypress CY3672 Development Kit comes complete with everything needed to design with the CY22050 and program samples and small prototype quantities. The kit comes with the latest version of CyClocksRT and a small portable programmer that connects to a PC for on-the-fly programming of custom frequencies.

The JEDEC file output of CyClocksRT can be downloaded to the portable programmer for small-volume programming, or for use with a production programming system for larger volumes.

Applications

Controlling Jitter

Jitter is defined in many ways, including: phase noise, long-term jitter, cycle-to-cycle jitter, period jitter, absolute jitter, and deterministic jitter. These jitter terms are usually given in terms of rms, peak-to-peak, or in the case of phase noise dBc/Hz with respect to the fundamental frequency. Actual jitter is dependent on XIN jitter and edge rate, number of active outputs, output frequencies, V_{DDL} (2.5 V or 3.3 V), temperature, and output load.

Power supply noise and clock output loading are two major system sources of clock jitter. Power supply noise can be mitigated by proper power supply decoupling (0.1- μ F ceramic cap) of the clock and ensuring a low-impedance ground to the chip. Reducing capacitive clock output loading to a minimum lowers current spikes on the clock edges and thus reduces jitter.

Reducing the total number of active outputs also reduce jitter in a linear fashion. However, it is better to use two outputs to drive two loads than one output to drive two loads.

The rate and magnitude that the PLL corrects the VCO frequency is directly related to jitter performance. If the rate is too slow, then long term jitter and phase noise is poor. Therefore, to improve long-term jitter and phase noise, reducing Q to a minimum is advisable. This technique increases the speed of the phase frequency detector, which in turn drives the input voltage of the VCO. In a similar manner, increasing P until the VCO is near its maximum rated speed also decreases long term jitter and phase noise. For example: input reference of 12 MHz; desired output frequency of 33.3 MHz. One might arrive at the following solution: Set Q = 3, P = 25, Post Div = 3. However, the best jitter results are Q = 2, P = 50, Post Div = 9.

For additional information, refer to the application note, "Jitter in PLL-based Systems: Causes, Effects, and Solutions," available at <http://www.cypress.com> (click on "Application Notes"), or contact your local Cypress Field Applications Engineer.

CY22050 Frequency Calculation

The CY22050 is an extremely flexible clock generator with up to six individual outputs, generated from an integrated PLL.

There are four variables used to determine the final output frequency. They are: the input REF, the P and Q dividers, and the post divider. The three basic formulas for determining the final output frequency of a CY22150-based design are:

- $CLK = ((REF * P)/Q)/Post\ Divider$
- $CLK = REF/Post\ Divider$
- $CLK = REF$

The basic PLL block diagram is shown in Figure 2. Each of the six clock outputs has a total of seven output options available to it. There are six post divider options: /2 (two of these), /3, /4, /DIV1N, and DIV2N. DIV1N and DIV2N are separately calculated and can be independent of each other. The post divider options can be applied to the calculated PLL frequency or to the REF directly.

In addition to the six post divider options, the seventh option bypasses the PLL and passes the REF directly to the crosspoint switch matrix.

Figure 2. Basic PLL Block Diagram

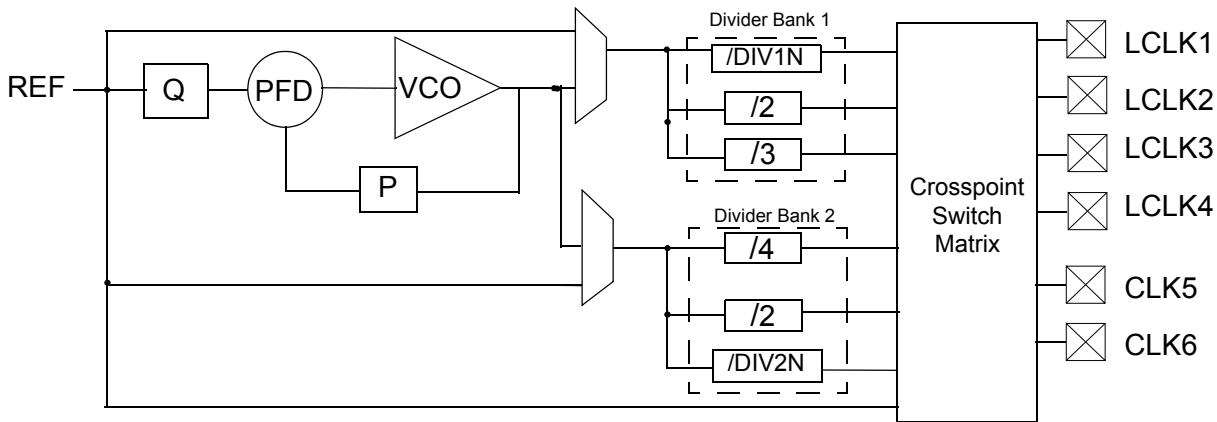

Clock Output Settings: Crosspoint Switch Matrix

Each of the six clock outputs can come from any of seven unique frequency sources. The crosspoint switch matrix defines which

source is attached to each individual clock output. Although it may seem that there are an unlimited number of divider options, there are several rules that must be taken into account when selecting divider options.

Table 1. Clock Output Definition

Clock Output Divider	Definition and Notes
None	Clock output source is the reference input frequency.
/DIV1N	Clock output uses a generated /DIV1N option from Divider Bank 1. Allowable values for DIV1N are 4 to 130. If Divider Bank 1 is not being used, set DIV1N to 8.
/2	Clock output uses a fixed /2 option from Divider Bank 1. If this option is used, DIV1N must be divisible by 4.
/3	Clock output uses a fixed /3 option from Divider Bank 1. If this option is used, set DIV1N to 6.
/DIV2N	Clock output uses a generated /DIV2N option from Divider Bank 2. Allowable values for DIV2N are 4 to 130. If Divider Bank 2 is not being used, set DIV2N to 8.
/2	Clock output uses a fixed /2 option from Divider Bank 2. If this option is used, DIV2N must be divisible by 4.
/4	Clock output 2 uses a fixed /4 option from Divider Bank 2. If this option is used, DIV2N must be divisible by 8.

Reference Crystal Input

The input crystal oscillator of the CY22050 is an important feature because of the flexibility it allows the user in selecting a crystal as a reference clock source. The oscillator inverter has programmable gain, allowing for maximum compatibility with a reference crystal, based on manufacturer, process, performance, and quality.

The value of the input load capacitors is determined by eight bits in a programmable register. Total load capacitance is determined by the formula:

$$\text{CapLoad} = (C_L - C_{BRD} - C_{CHIP})/0.09375 \text{ pF}$$

In CyClocksRT, enter the crystal capacitance (C_L). The value of CapLoad is determined automatically and programmed into the CY22050.

If you require greater control over the CapLoad value, consider using the CY22150 for serial configuration and control of the input load capacitors. For an external clock source, the default is 0.

Input load capacitors are placed on the CY22050 die to reduce external component cost. These capacitors are true parallel-plate capacitors, designed to reduce the frequency shift that occurs when non-linear load capacitance is affected by load, bias, supply, and temperature changes.

Crystal Drive Level and Power

Crystals are specified to accept a maximum drive level. Generally, larger crystals can accept more power. The drive level specification in the table below is a general upper bound for the power driven by the oscillator circuit in the CY22050.

For a given voltage swing, power dissipation in the crystal is proportional to ESR and proportional to the square of the crystal frequency. (Note that actual ESR is sometimes much less than the value specified by the crystal manufacturer.) Power is also almost proportional to the square of C_L .

Power can be reduced to less than the DL specification in the table below by selecting a reduced frequency crystal with low C_L and low R_1 (ESR).

Absolute Maximum Conditions

Parameter	Description	Min	Max	Unit
V_{DD}	Supply Voltage	-0.5	7.0	V
V_{DDL}	I/O Supply Voltage	-0.5	7.0	V
T_S	Storage Temperature [3]	-65	125	°C
T_J	Junction Temperature	-	125	°C
	Package Power Dissipation—Commercial Temp	-	450	mW
	Package Power Dissipation—Industrial Temp	-	380	mW
	Digital Inputs	$AV_{SS} - 0.3$	$AV_{DD} + 0.3$	V
	Digital Outputs referred to V_{DD}	$V_{SS} - 0.3$	$V_{DD} + 0.3$	V
	Digital Outputs referred to V_{DDL}	$V_{SS} - 0.3$	$V_{DDL} + 0.3$	V
ESD	Static Discharge Voltage per MIL-STD-833, Method 3015	-	2000	V

Note

3. Rated for 10 years

Recommended Operating Conditions

Parameter	Description	Min	Typ	Max	Unit
V _{DD}	Operating Voltage	3.135	3.3	3.465	V
V _{DDLHI}	Operating Voltage	3.135	3.3	3.465	V
V _{DDLLO}	Operating Voltage	2.375	2.5	2.625	V
T _{AC}	Ambient Commercial Temp	0	–	70	°C
T _{AI}	Ambient Industrial Temp	–40	–	85	°C
C _{LOAD}	Max. Load Capacitance V _{DD} /V _{DDL} = 3.3 V	–	–	15	pF
C _{LOAD}	Max. Load Capacitance V _{DDL} = 2.5 V	–	–	15	pF
f _{REFD}	Driven REF	1	–	133	MHz
f _{REFC}	Crystal REF	8	–	30	MHz
t _{PU}	Power up time for all V _{DD} s to reach minimum specified voltage (power ramps must be monotonic)	0.05	–	500	ms

Recommended Crystal Specifications

Parameter	Description	Comments	Min	Typ	Max	Unit
f _{NOM}	Nominal crystal frequency	Parallel resonance, fundamental mode	8	–	30	MHz
C _{LNOM}	Nominal load capacitance		10	–	20	pF
R ₁	Equivalent series resistance (ESR)	Fundamental mode	–	–	50	Ω
DL	Crystal drive level	No external series resistor assumed	–	0.5	2	mW

DC Electrical Characteristics

Parameter ^[4]	Description	Condition	Min	Typ	Max	Unit
$I_{OH3.3}$	Output High Current	$V_{OH} = V_{DD} - 0.5\text{ V}$, $V_{DD}/V_{DDL} = 3.3\text{ V}$	12	24	–	mA
$I_{OL3.3}$	Output Low Current	$V_{OL} = 0.5\text{ V}$, $V_{DD}/V_{DDL} = 3.3\text{ V}$	12	24	–	mA
$I_{OH2.5}$	Output High Current	$V_{OH} = V_{DDL} - 0.5\text{ V}$, $V_{DDL} = 2.5\text{ V}$	8	16	–	mA
$I_{OL2.5}$	Output Low Current	$V_{OL} = 0.5\text{ V}$, $V_{DDL} = 2.5\text{ V}$	8	16	–	mA
V_{IH}	Input High Voltage	CMOS levels, 70% of V_{DD}	0.7	–	1.0	V_{DD}
V_{IL}	Input Low Voltage	CMOS levels, 30% of V_{DD}	0	–	0.3	V_{DD}
I_{VDD} ^[5, 6]	Supply Current	AV_{DD}/V_{DD} Current	–	45	–	mA
$I_{VDDL3.3}$ ^[5, 6]	Supply Current	V_{DDL} Current ($V_{DDL} = 3.465\text{ V}$)	–	25	–	mA
$I_{VDDL2.5}$ ^[5, 6]	Supply Current	V_{DDL} Current ($V_{DDL} = 2.625\text{ V}$)	–	17	–	mA
I_{DDS}	Power Down Current	$V_{DD} = V_{DDL} = AV_{DD} = 3.465\text{ V}$	–	–	50	μA
I_{OHZ} I_{OLZ}	Output Leakage	$V_{DD} = V_{DDL} = AV_{DD} = 3.465\text{ V}$	–	–	10	μA

AC Electrical Characteristics

Parameter ^[4]	Description	Condition	Min	Typ	Max	Unit
t_1	Output frequency, commercial temperature	Clock output limit, 3.3 V	0.008 (8 kHz)	–	200	MHz
		Clock output limit, 2.5 V	0.008 (8 kHz)	–	166.6	MHz
	Output frequency, industrial temperature	Clock output limit, 3.3 V	0.008 (8 kHz)	–	166.6	MHz
		Clock output limit, 2.5 V	0.008 (8 kHz)	–	150	MHz
t_2	Output duty cycle	Duty cycle is defined in Figure 4, t_1/t_2 , $f_{OUT} > 166\text{ MHz}$, 50% of V_{DD}	40	50	60	%
		Duty cycle is defined in Figure 4, t_1/t_2 , $f_{OUT} < 166\text{ MHz}$, 50% of V_{DD}	45	50	55	%
t_{3LO}	Rising edge slew rate ($V_{DDL} = 2.5\text{ V}$)	Output clock rise time, 20%–80% of V_{DDL} , defined in Figure 5	0.6	1.2	–	V/ns
t_{4LO}	Falling edge slew rate ($V_{DDL} = 2.5\text{ V}$)	Output clock fall time, 80%–20% of V_{DDL} , defined in Figure 5	0.6	1.2	–	V/ns
t_{3HI}	Rising edge slew rate ($V_{DDL} = 3.3\text{ V}$)	Output clock rise time, 20%–80% of V_{DD}/V_{DDL} , defined in Figure 5	0.8	1.4	–	V/ns
t_{4HI}	Falling edge slew rate ($V_{DDL} = 3.3\text{ V}$)	Output clock fall time, 80%–20% of V_{DD}/V_{DDL} , defined in Figure 5	0.8	1.4	–	V/ns
t_5 ^[7]	Skew	Output-output skew between related outputs	–	–	250	ps
t_6 ^[8]	Clock jitter	Peak-to-peak period jitter (see Figure 6)	–	250	–	ps
t_{10}	PLL lock time		–	0.30	3	ms

Notes

- Not 100% tested, guaranteed by design.
- I_{VDD} currents specified for two CLK outputs running at 125 MHz, two LCLK outputs running at 80 MHz, and two LCLK outputs running at 66.6 MHz. All outputs are loaded with 15 pF.
- Use CyClocksRT to calculate actual I_{VDD} and I_{VDDL} for specific output frequency configurations.
- Skew value guaranteed when outputs are generated from the same divider bank. See Logic Block Diagram for more information.
- Jitter measurement will vary. Actual jitter is dependent on X_{IN} jitter and edge rate, number of active outputs, output frequencies, V_{DDL} (2.5 V or 3.3 V), temperature, and output load. For more information, refer to the application note, "Jitter in PLL-based Systems: Causes, Effects, and Solutions," available at <http://www.cypress.com>, or contact your local Cypress Field Applications Engineer.

Test Circuit

Figure 3. Test Circuit

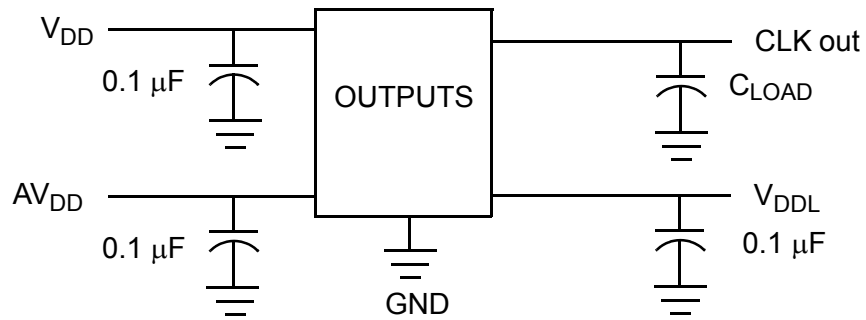

Switching Waveforms

Figure 4. Duty Cycle Definition: $DC = t2/t1$

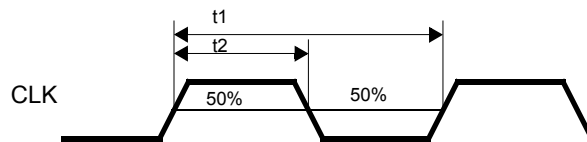

Figure 5. Rise and Fall Time Definitions

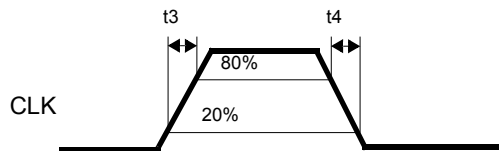
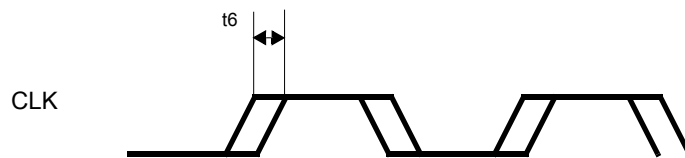

Figure 6. Peak-to-Peak Jitter



16-pin TSSOP Package Characteristics

Parameter	Name	Value	Unit
θ_{JA}	theta JA	115	°C/W
Complexity	Transistor Count	74,600	Transistors

Package Drawing and Dimensions

Figure 7. 16-pin TSSOP 4.40 mm Body Z16.173/ZZ16.173 Package Outline, 51-85091

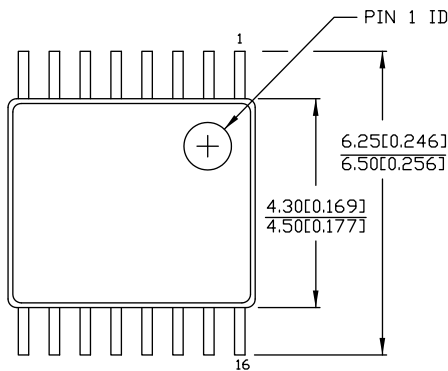

DIMENSIONS IN MM[INCHES] MIN.
MAX.

REFERENCE JEDEC MO-153

PACKAGE WEIGHT 0.05gms

PART #	
Z16.173	STANDARD PKG.
ZZ16.173	LEAD FREE PKG.

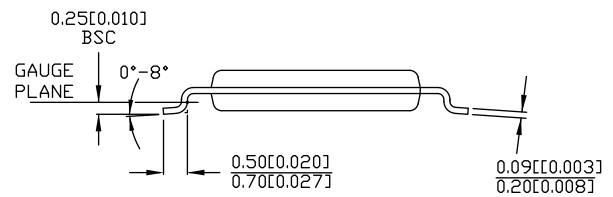
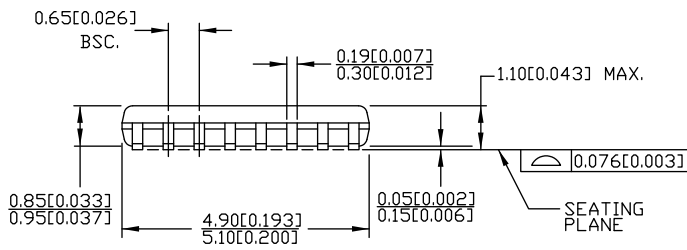

51-85091 *E

Acronyms

Acronym	Description
ESR	Equivalent Series Resistance
FAE	Field Application Engineer
I/O	Input/Output
JEDEC	Joint Electron Devices Engineering Council
OE	Output Enable
PC	Personal Computer
PCB	Printed Circuit Board
PLL	Phase-Locked Loop
TSSOP	Thin Shrunk Small Outline Package
VCO	Voltage Controlled Oscillator

Document Conventions

Units of Measure

Symbol	Unit of Measure
°C	degree Celsius
dBC	decibels relative to carrier
Hz	hertz
kHz	kilohertz
MHz	megahertz
μA	microampere
μF	microfarad
mA	milliampere
mm	millimeter
ms	millisecond
mW	milliwatt
ns	nanosecond
Ω	ohm
%	percent
pF	picofarad
ps	picosecond
V	volt
W	watt

Document History Page

Document Title: CY22050, One-PLL General-Purpose Flash-Programmable Clock Generator				
Document Number: 38-07006				
Rev.	ECN	Orig. of Change	Submission Date	Description of Change
**	108185	CKN	08/08/01	New data sheet.
*A	110054	CKN	03/04/02	Changed status from Preliminary to Final.
*B	121862	RBI	12/14/02	Power up requirements added to Operating Conditions Information.
*C	310575	RGL	01/20/05	Added Lead-free devices.
*D	314233	RGL	01/31/05	Removed the Tape and Reel devices in the non-dash parts.
*E	2440826	AESA	05/15/08	Added Note "Not recommended for new designs." and "38-07409, CY3672 PTG Programming Kit". Corrected "FTG" to "PTG" in Ordering information table. Added part numbers CY22050KFC, CY22050KFI, CY22050KFZXC, CY22050KFZXI, CY22050KZXC-xxx, CY22050KZXC-xxxT, CY22050KZXI-xxx, and CY22050KZXI-xxxT in ordering information table. Changed Lead-Free to Pb-free. Updated to new template.
*F	2642064	KVM	01/21/09	Added CY220501 to title. Added CY220501KFZXI to ordering table.
*G	2743347	KVM	07/24/09	Revised the Device Selection table on page 1 and renamed it. Updates to programmer and software descriptions. Clarified that I _{VDD} and I _{VDDL} are for loaded outputs. Updated footnotes to show that the standard part numbers are now with a "K". Changed CY3672 part number to CY3672-USB, changed CY3672ADP000 to CY3695, and repositioned them in the Ordering Information table. Deleted part numbers CY22050ZC-xxxT, CY22050ZI-xxx and CY22050ZI-xxxT.
*H	2899683	KVM	03/26/10	Updated Ordering Information : Removed inactive parts from ordering information table. Updated Possible Configurations : Moved xxx parts to 'Possible Configurations' table. Updated Package Drawing and Dimensions .
*I	3167517	BASH	02/09/11	Add crystal parameter table on page 6, ordering code definition, acronym and units tables. Remove references to FTG. Deleted table 1 from page 1, device selection: this table provides no additional information. Consolidated its input/output range information as a "features" bullet. Removed "benefits" section. Updated footnote#9 on page 8.
*J	3210223	BASH	03/30/2011	Updated Ordering Information (Removed CY220501KFZXI, CY22050KZXC-139 and CY22050KZXC-139T). Updated Package Drawing and Dimensions (spec 51-85091 (Changed revision from *B to *C)).
*K	3366417	PURU	09/08/2011	Updated to new template.
*L	3776296	PURU	10/12/2012	Updated Ordering Information (Updated part numbers (Added a new MPN namely CY22050KFZXCT)). Updated Package Drawing and Dimensions (spec 51-85091 (Changed revision from *C to *D)).

Document History Page (continued)

Document Title: CY22050, One-PLL General-Purpose Flash-Programmable Clock Generator				
Document Number: 38-07006				
Rev.	ECN	Orig. of Change	Submission Date	Description of Change
*M	4531394	TAVA	10/15/2014	Updated Features : Replaced 80 kHz with 8 kHz under "Output frequency range". Updated Clock Output Settings: Crosspoint Switch Matrix : Updated Table 1 : Replaced "127" with "130" in "Definition and Notes" column corresponding to "/DIV1N" and "/DIV2N". Updated AC Electrical Characteristics : Replaced 80 kHz with 8 kHz and 0.08 MHz with 0.008 MHz in minimum value of t ₁ parameter. Updated to new template. Completing Sunset Review.
*N	4575273	TAVA	11/20/2014	Added related documentation hyperlink in page 1. Updated Ordering Information : Removed pruned part CY22050KFC. Updated Package Drawing and Dimensions .
*O	4643736	TAVA	01/28/2015	Removed CY220501 related information in all instances across the document as the CY220501 MPN has already been removed in ordering information as the part got pruned. Updated Document Title to read as "CY22050, One-PLL General-Purpose Flash-Programmable Clock Generator". Updated Ordering Information : Updated Possible Configurations : Updated details in "Ordering Code" column.

Sales, Solutions, and Legal Information

Worldwide Sales and Design Support

Cypress maintains a worldwide network of offices, solution centers, manufacturer's representatives, and distributors. To find the office closest to you, visit us at [Cypress Locations](#).

Products

Automotive	cypress.com/go/automotive
Clocks & Buffers	cypress.com/go/clocks
Interface	cypress.com/go/interface
Lighting & Power Control	cypress.com/go/powerpsoc cypress.com/go/plc
Memory	cypress.com/go/memory
PSoC	cypress.com/go/psoc
Touch Sensing	cypress.com/go/touch
USB Controllers	cypress.com/go/USB
Wireless/RF	cypress.com/go/wireless

PSoC[®] Solutions

[psoc.cypress.com/solutions](#)
[PSoC 1](#) | [PSoC 3](#) | [PSoC 4](#) | [PSoC 5LP](#)

Cypress Developer Community

[Community](#) | [Forums](#) | [Blogs](#) | [Video](#) | [Training](#)

Technical Support

[cypress.com/go/support](#)

© Cypress Semiconductor Corporation, 2001-2015. The information contained herein is subject to change without notice. Cypress Semiconductor Corporation assumes no responsibility for the use of any circuitry other than circuitry embodied in a Cypress product. Nor does it convey or imply any license under patent or other rights. Cypress products are not warranted nor intended to be used for medical, life support, life saving, critical control or safety applications, unless pursuant to an express written agreement with Cypress. Furthermore, Cypress does not authorize its products for use as critical components in life-support systems where a malfunction or failure may reasonably be expected to result in significant injury to the user. The inclusion of Cypress products in life-support systems application implies that the manufacturer assumes all risk of such use and in doing so indemnifies Cypress against all charges.

Any Source Code (software and/or firmware) is owned by Cypress Semiconductor Corporation (Cypress) and is protected by and subject to worldwide patent protection (United States and foreign), United States copyright laws and international treaty provisions. Cypress hereby grants to licensee a personal, non-exclusive, non-transferable license to copy, use, modify, create derivative works of, and compile the Cypress Source Code and derivative works for the sole purpose of creating custom software and or firmware in support of licensee product to be used only in conjunction with a Cypress integrated circuit as specified in the applicable agreement. Any reproduction, modification, translation, compilation, or representation of this Source Code except as specified above is prohibited without the express written permission of Cypress.

Disclaimer: CYPRESS MAKES NO WARRANTY OF ANY KIND, EXPRESS OR IMPLIED, WITH REGARD TO THIS MATERIAL, INCLUDING, BUT NOT LIMITED TO, THE IMPLIED WARRANTIES OF MERCHANTABILITY AND FITNESS FOR A PARTICULAR PURPOSE. Cypress reserves the right to make changes without further notice to the materials described herein. Cypress does not assume any liability arising out of the application or use of any product or circuit described herein. Cypress does not authorize its products for use as critical components in life-support systems where a malfunction or failure may reasonably be expected to result in significant injury to the user. The inclusion of Cypress' product in a life-support systems application implies that the manufacturer assumes all risk of such use and in doing so indemnifies Cypress against all charges.

Use may be limited by and subject to the applicable Cypress software license agreement.

Looking for pricing, stock, or lifecycle information?

Click below to explore more details on WIN SOURCE:

 [View CY22050KFZXI on WIN SOURCE](#)

 [Infineon Technologies](#) Information

Optimize Your Supply Chain with WIN SOURCE Solutions

-  Global Sourcing Solution
-  Obsolete Management
-  Cost Control Management
-  Shortage Management
-  Alternative Solution
-  Excess Inventory Management