



**THE DATASHEET OF  
STPSC2006CW**



## 600 V power Schottky silicon carbide diode

### Features

- No or negligible reverse recovery
- Switching behavior independent of temperature
- Particularly suitable in PFC boost diode function

### Description

The SiC diode is an ultrahigh performance power Schottky diode. It is manufactured using a silicon carbide substrate. The wide band gap material allows the design of a Schottky diode structure with a 600 V rating. Due to the Schottky construction no recovery is shown at turn-off and ringing patterns are negligible. The minimal capacitive turn-off behavior is independent of temperature.

ST SiC diodes will boost the performance of PFC operations in hard switching conditions.

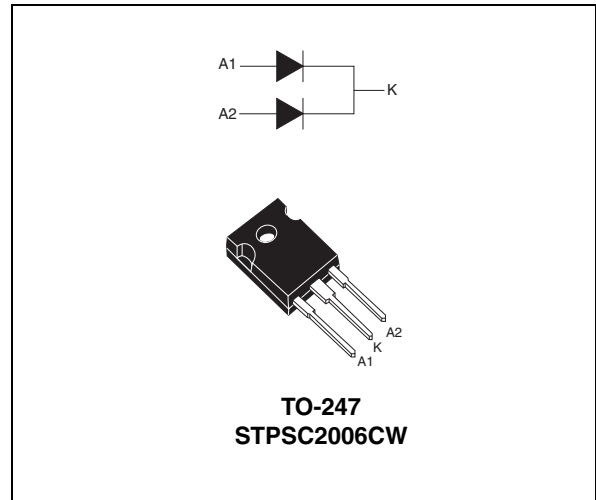

**Table 1. Device summary**

Symbol	Value
$I_{F(AV)}$	2 x 10 A
$V_{RRM}$	600 V
$T_j (max)$	175 °C
$Q_C (typ)$	12 nC

# 1 Characteristics

**Table 2. Absolute ratings (limiting values at 25 °C unless otherwise specified, per diode)**

Symbol	Parameter		Value	Unit	
$V_{RRM}$	Repetitive peak reverse voltage		600	V	
$I_{F(RMS)}$	Forward rms current		18	A	
$I_{F(AV)}$	Average forward current	$T_c = 115\text{ °C}, \delta = 0.5$	Per diode	10	A
		$T_c = 100\text{ °C}, \delta = 0.5$	Per device	20	A
$I_{FSM}$	Surge non repetitive forward current	$t_p = 10\text{ ms sinusoidal}, T_c = 25\text{ °C}$		40	A
		$t_p = 10\text{ ms sinusoidal}, T_c = 125\text{ °C}$		32	
		$t_p = 10\text{ }\mu\text{s square}, T_c = 25\text{ °C}$		160	
$I_{FRM}$	Repetitive peak forward current	$\delta = 0.1, T_c = 110\text{ °C}, T_j = 150\text{ °C}$	40	A	
$T_{stg}$	Storage temperature range		-55 to +175	°C	
$T_j$	Maximum operating junction temperature range		-40 to +175	°C	

**Table 3. Thermal resistance**

Symbol	Parameter		Value	Unit
$R_{th(j-c)}$	Junction to case	Per diode	2	°C/W
		Total	1.2	°C/W
$R_{th(c)}$	Coupling		0.4	°C/W

**Table 4. Static electrical characteristics per diode**

Symbol	Parameter	Tests conditions		Min.	Typ.	Max.	Unit
$I_R^{(1)}$	Reverse leakage current	$T_j = 25\text{ °C}$	$V_R = V_{RRM}$	-	30	150	$\mu\text{A}$
		$T_j = 150\text{ °C}$		-	210	1500	
$V_F^{(2)}$	Forward voltage drop	$T_j = 25\text{ °C}$	$I_F = 10\text{ A}$	-	1.4	1.7	V
		$T_j = 150\text{ °C}$		-	1.6	2.1	

1.  $t_p = 10\text{ ms}, \delta < 2\%$

2.  $t_p = 500\text{ }\mu\text{s}, \delta < 2\%$

To evaluate the conduction losses use the following equation:

$$P = 1.2 \times I_{F(AV)} + 0.09 \times I_{F(RMS)}^2$$

**Table 5. Other parameters per diode**

Symbol	Parameter	Test conditions	Typ.	Unit
$Q_C$	Total capacitive charge	$V_r = 400\text{ V}, I_F = 10\text{ A}, di_F/dt = -200\text{ A}/\mu\text{s}$ $T_j = 150\text{ °C}$	12	nC
C	Total capacitance	$V_r = 0\text{ V}, T_c = 25\text{ °C}, F = 1\text{ Mhz}$	650	pF

**Figure 1. Forward voltage drop versus forward current (typical values, per diode)**

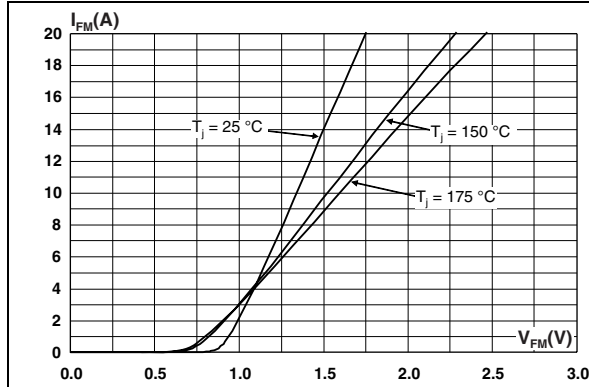

**Figure 2. Reverse leakage current versus reverse voltage applied (maximum values, per diode)**

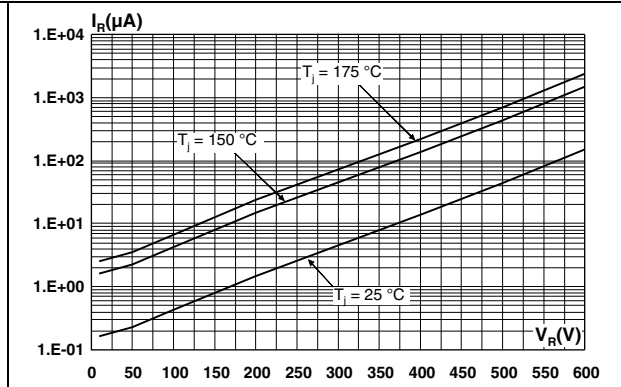

**Figure 3. Peak forward current versus case temperature (per diode)**

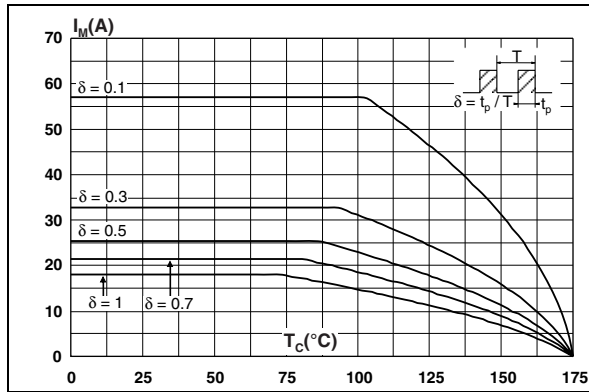

**Figure 4. Junction capacitance versus reverse voltage applied (typical values, per diode)**

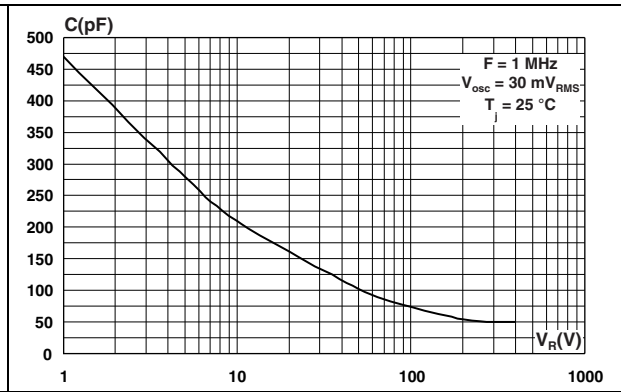

**Figure 5. Relative variation of thermal impedance junction to case versus pulse duration**

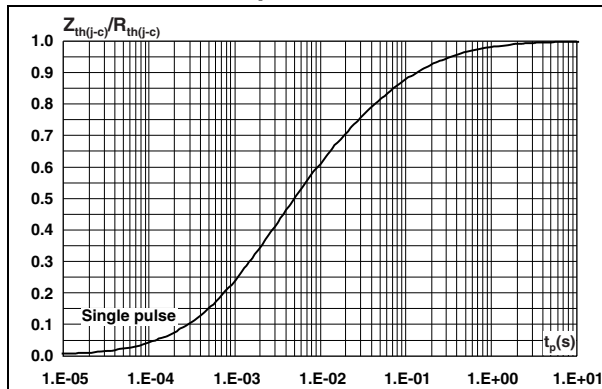

**Figure 6. Non-repetitive peak surge forward current versus pulse duration (sinusoidal waveform, per diode)**

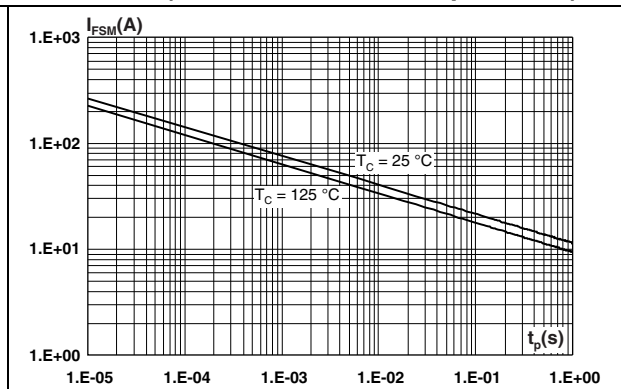
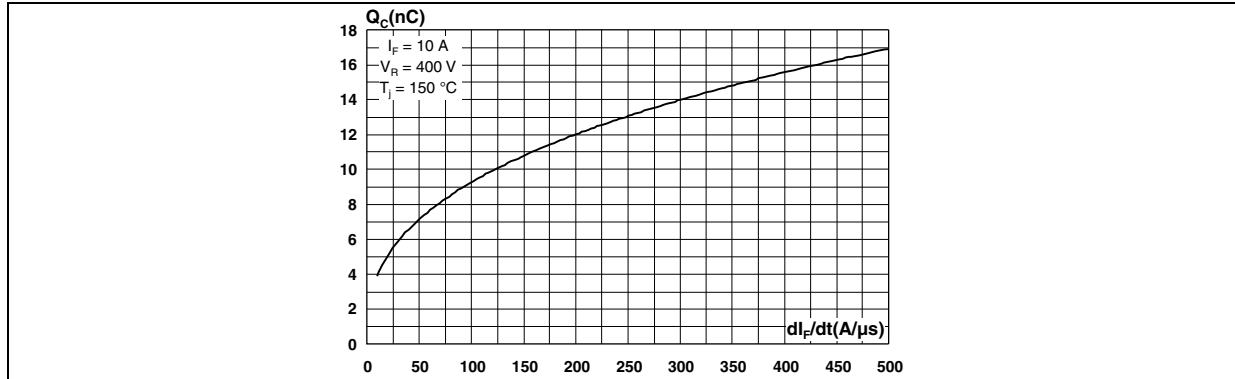

Figure 7. Total capacitive charge versus  $di_F/dt$  (typical values, per diode)



## 2 Package information

- Epoxy meets UL94, V0
- Cooling method: convection (C)
- Recommended torque value: 0.55 to 1.0 N·m

In order to meet environmental requirements, ST offers these devices in different grades of ECOPACK® packages, depending on their level of environmental compliance. ECOPACK® specifications, grade definitions and product status are available at: [www.st.com](http://www.st.com). ECOPACK® is an ST trademark.

**Table 6. TO-247 dimensions**

Ref.	Dimensions			
	Millimeters		Inches	
	Min.	Max.	Min.	Max.
A	4.85	5.16	0.191	0.203
D	2.20	2.60	0.086	0.102
E	0.40	0.80	0.015	0.031
F	1.00	1.40	0.039	0.055
F1	3.00 typ.		0.118 typ.	
F2	2.00 typ.		0.079 typ.	
F3	1.90	2.40	0.075	0.094
F4	3.00	3.40	0.118	0.134
G	10.90 typ.		0.429 typ.	
H	15.45	16.03	0.608	0.631
L	19.85	21.09	0.781	0.830
L1	3.70	4.30	0.146	0.169
L2	18.30	19.13	0.720	0.753
L3	14.20	20.30	0.559	0.799
L4	34.05	41.38	1.341	1.629
L5	5.35	6.30	0.211	0.248
M	2.00	3.00	0.079	0.118
V	5° typ.		5° typ.	
V2	60° typ.		60° typ.	
Dia.	3.55	3.65	0.140	0.144

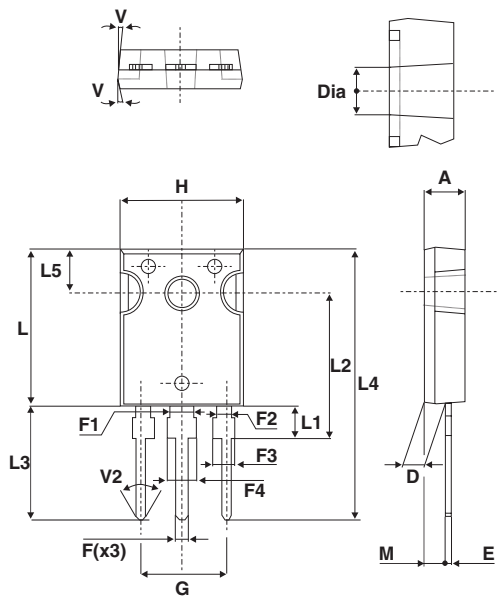

### 3 Ordering information

**Table 7. Ordering information**

Order code	Marking	Package	Weight	Base qty	Delivery mode
STPSC2006CW	STPSC2006CW	TO-247	4.36 g	30	Tube

### 4 Revision history

**Table 8. Document revision history**

Date	Revision	Changes
01-Mar-2011	1	First issue.

**Please Read Carefully:**

Information in this document is provided solely in connection with ST products. STMicroelectronics NV and its subsidiaries ("ST") reserve the right to make changes, corrections, modifications or improvements, to this document, and the products and services described herein at any time, without notice.

All ST products are sold pursuant to ST's terms and conditions of sale.

Purchasers are solely responsible for the choice, selection and use of the ST products and services described herein, and ST assumes no liability whatsoever relating to the choice, selection or use of the ST products and services described herein.

No license, express or implied, by estoppel or otherwise, to any intellectual property rights is granted under this document. If any part of this document refers to any third party products or services it shall not be deemed a license grant by ST for the use of such third party products or services, or any intellectual property contained therein or considered as a warranty covering the use in any manner whatsoever of such third party products or services or any intellectual property contained therein.

**UNLESS OTHERWISE SET FORTH IN ST'S TERMS AND CONDITIONS OF SALE ST DISCLAIMS ANY EXPRESS OR IMPLIED WARRANTY WITH RESPECT TO THE USE AND/OR SALE OF ST PRODUCTS INCLUDING WITHOUT LIMITATION IMPLIED WARRANTIES OF MERCHANTABILITY, FITNESS FOR A PARTICULAR PURPOSE (AND THEIR EQUIVALENTS UNDER THE LAWS OF ANY JURISDICTION), OR INFRINGEMENT OF ANY PATENT, COPYRIGHT OR OTHER INTELLECTUAL PROPERTY RIGHT.**

**UNLESS EXPRESSLY APPROVED IN WRITING BY AN AUTHORIZED ST REPRESENTATIVE, ST PRODUCTS ARE NOT RECOMMENDED, AUTHORIZED OR WARRANTED FOR USE IN MILITARY, AIR CRAFT, SPACE, LIFE SAVING, OR LIFE SUSTAINING APPLICATIONS, NOR IN PRODUCTS OR SYSTEMS WHERE FAILURE OR MALFUNCTION MAY RESULT IN PERSONAL INJURY, DEATH, OR SEVERE PROPERTY OR ENVIRONMENTAL DAMAGE. ST PRODUCTS WHICH ARE NOT SPECIFIED AS "AUTOMOTIVE GRADE" MAY ONLY BE USED IN AUTOMOTIVE APPLICATIONS AT USER'S OWN RISK.**

Resale of ST products with provisions different from the statements and/or technical features set forth in this document shall immediately void any warranty granted by ST for the ST product or service described herein and shall not create or extend in any manner whatsoever, any liability of ST.

ST and the ST logo are trademarks or registered trademarks of ST in various countries.

Information in this document supersedes and replaces all information previously supplied.

The ST logo is a registered trademark of STMicroelectronics. All other names are the property of their respective owners.

© 2011 STMicroelectronics - All rights reserved

STMicroelectronics group of companies

Australia - Belgium - Brazil - Canada - China - Czech Republic - Finland - France - Germany - Hong Kong - India - Israel - Italy - Japan - Malaysia - Malta - Morocco - Philippines - Singapore - Spain - Sweden - Switzerland - United Kingdom - United States of America

[www.st.com](http://www.st.com)

## Looking for pricing, stock, or lifecycle information?

Click below to explore more details on WIN SOURCE:

- ⊖ [View STPSC2006CW](#) on WIN SOURCE
- ⊖ [STMicroelectronics](#) Information

## Optimize Your Supply Chain with WIN SOURCE Solutions

- ✓ Global Sourcing Solution
- ✓ Obsolete Management
- ✓ Cost Control Management
- ✓ Shortage Management
- ✓ Alternative Solution
- ✓ Excess Inventory Management