



THE DATASHEET OF CDC582PAH



CDC582

3.3-V PHASE-LOCK LOOP CLOCK DRIVER WITH DIFFERENTIAL LVPECL CLOCK INPUTS

SCAS446B – JULY 1994 – REVISED FEBRUARY 1996

- Low Output Skew for Clock-Distribution and Clock-Generation Applications
- Operates at 3.3-V V_{CC}
- Distributes Differential LVPECL Clock Inputs to 12 TTL-Compatible Outputs
- Two Select Inputs Configure Up to Nine Outputs to Operate at One-Half or Double the Input Frequency
- No External RC Network Required
- State-of-the-Art *EPIC-IIB*™ BiCMOS Design Significantly Reduces Power Dissipation
- External Feedback Input (FBIN) Is Used to Synchronize the Outputs With the Clock Inputs
- Application for Synchronous DRAMs
- Distributed V_{CC} and Ground Pins Reduce Switching Noise
- Packaged in 52-Pin Quad Flatpack

PAH PACKAGE
(TOP VIEW)

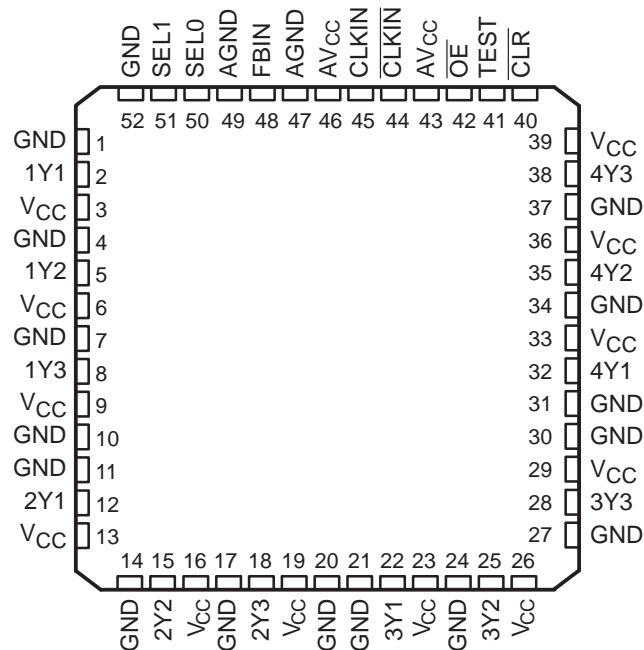

description

The CDC582 is a high-performance, low-skew, low-jitter clock driver. It uses a phase-lock loop (PLL) to precisely align the frequency and phase of the clock output signals to the differential LVPECL clock (CLKIN, $\overline{\text{CLKIN}}$) input signals. It is specifically designed to operate at speeds from 50 MHz to 100 MHz or down to 25 MHz on outputs configured as half-frequency outputs. The CDC582 operates at 3.3-V V_{CC} .

The feedback input (FBIN) synchronizes the frequency of the output clocks with the input clock (CLKIN, $\overline{\text{CLKIN}}$) signals. One of the twelve output clocks must be fed back to FBIN for the PLL to maintain synchronization between the differential CLKIN and $\overline{\text{CLKIN}}$ inputs and the outputs. The output used as feedback is synchronized to the same frequency as the clock (CLKIN and $\overline{\text{CLKIN}}$) inputs.



Please be aware that an important notice concerning availability, standard warranty, and use in critical applications of Texas Instruments semiconductor products and disclaimers thereto appears at the end of this data sheet.

EPIC-IIB is a trademark of Texas Instruments Incorporated.

PRODUCTION DATA information is current as of publication date. Products conform to specifications per the terms of Texas Instruments standard warranty. Production processing does not necessarily include testing of all parameters.



POST OFFICE BOX 655303 • DALLAS, TEXAS 75265
POST OFFICE BOX 1443 • HOUSTON, TEXAS 77251-1443

Copyright © 1996, Texas Instruments Incorporated

CDC582

3.3-V PHASE-LOCK LOOP CLOCK DRIVER WITH DIFFERENTIAL LVPECL CLOCK INPUTS

SCAS446B – JULY 1994 – REVISED FEBRUARY 1996

description (continued)

The Y outputs can be configured to switch in phase and at the same frequency as differential clock inputs (CLKIN and $\overline{\text{CLKIN}}$). Select (SEL1, SEL0) inputs configure up to nine Y outputs, in banks of three, to operate at one-half or double the differential clock input frequency, depending upon the feedback configuration (see Tables 1 and 2). All output signal duty cycles are adjusted to 50% independent of the duty cycle at the input clocks.

Output-enable ($\overline{\text{OE}}$) is provided for output control. When $\overline{\text{OE}}$ is high, the outputs are in the low state. When $\overline{\text{OE}}$ is low, the outputs are active. $\overline{\text{CLR}}$ is negative-edge triggered and can be used to reset the outputs operating at half frequency. TEST is used for factory testing of the device and can be used to bypass the PLL. TEST should be strapped to GND for normal operation.

Unlike many products containing a PLL, the CDC582 does not require external RC networks. The loop filter for the PLL is included on chip, minimizing component count, board space, and cost.

Because it is based on PLL circuitry, the CDC582 requires a stabilization time to achieve phase lock of the feedback signal to the reference signal. This stabilization time is required following power up and application of a fixed-frequency, fixed-phase signal at CLKIN and $\overline{\text{CLKIN}}$, as well as following any changes to the PLL reference or feedback signal. Such changes occur upon change of SEL1 and SEL0, enabling the PLL via TEST, and upon enable of all outputs via $\overline{\text{OE}}$.

The CDC582 is characterized for operation from 0°C to 70°C.

detailed description of output configurations

The voltage-controlled oscillator (VCO) used in the CDC582 has a frequency range of 100 MHz to 200 MHz, twice the operating frequency range of the CDC582 outputs. The output of the VCO is divided by 2 and by 4 to provide reference frequencies with a 50% duty cycle of one-half and one-fourth the VCO frequency. SEL0 and SEL1 determine which of the two signals are buffered to each bank of device outputs.

One device output must be externally wired to FBIN to complete the PLL. The VCO operates such that the frequency of this output matches that of the CLKIN/ $\overline{\text{CLKIN}}$ signals. In the case that a VCO/2 output is wired to FBIN, the VCO must operate at twice the CLKIN/ $\overline{\text{CLKIN}}$ frequency, resulting in device outputs that operate at the same or one-half the CLKIN/ $\overline{\text{CLKIN}}$ frequency. If a VCO/4 output is wired to FBIN, the device outputs operate at the same or twice the CLKIN/ $\overline{\text{CLKIN}}$ frequency.

output configuration A

Output configuration A is valid when any output configured as a 1× frequency output in Table 1 is fed back to FBIN. The frequency range for the differential clock input is 50 MHz to 100 MHz when using output configuration A. Outputs configured as 1/2× outputs operate at half the input clock frequency, while outputs configured as 1× outputs operate at the same frequency as the differential clock input.

Table 1. Output Configuration A

INPUTS		OUTPUTS	
SEL1	SEL0	1/2× FREQUENCY	1× FREQUENCY
L	L	None	All
L	H	1Yn	2Yn, 3Yn, 4Yn
H	L	1Yn, 2Yn	3Yn, 4Yn
H	H	1Yn, 2Yn, 3Yn	4Yn

NOTE: n = 1, 2, 3



output configuration B

Output configuration B is valid when any output configured as a 1× frequency output in Table 2 is fed back to FBIN. The frequency range for the differential clock inputs is 25 MHz to 50 MHz when using output configuration B. Outputs configured as 1× outputs operate at the input clock frequency, while outputs configured as 2× outputs operate at double the frequency of the differential clock inputs.

Table 2. Output Configuration B

INPUTS		OUTPUTS	
SEL1	SEL0	1× FREQUENCY	2× FREQUENCY
L	L	All	None
L	H	1Yn	2Yn, 3Yn, 4Yn
H	L	1Yn, 2Yn	3Yn, 4Yn
H	H	1Yn, 2Yn, 3Yn	4Yn

NOTE: n = 1, 2, 3

CDC582

3.3-V PHASE-LOCK LOOP CLOCK DRIVER WITH DIFFERENTIAL LVPECL CLOCK INPUTS

SCAS446B – JULY 1994 – REVISED FEBRUARY 1996

functional block diagram

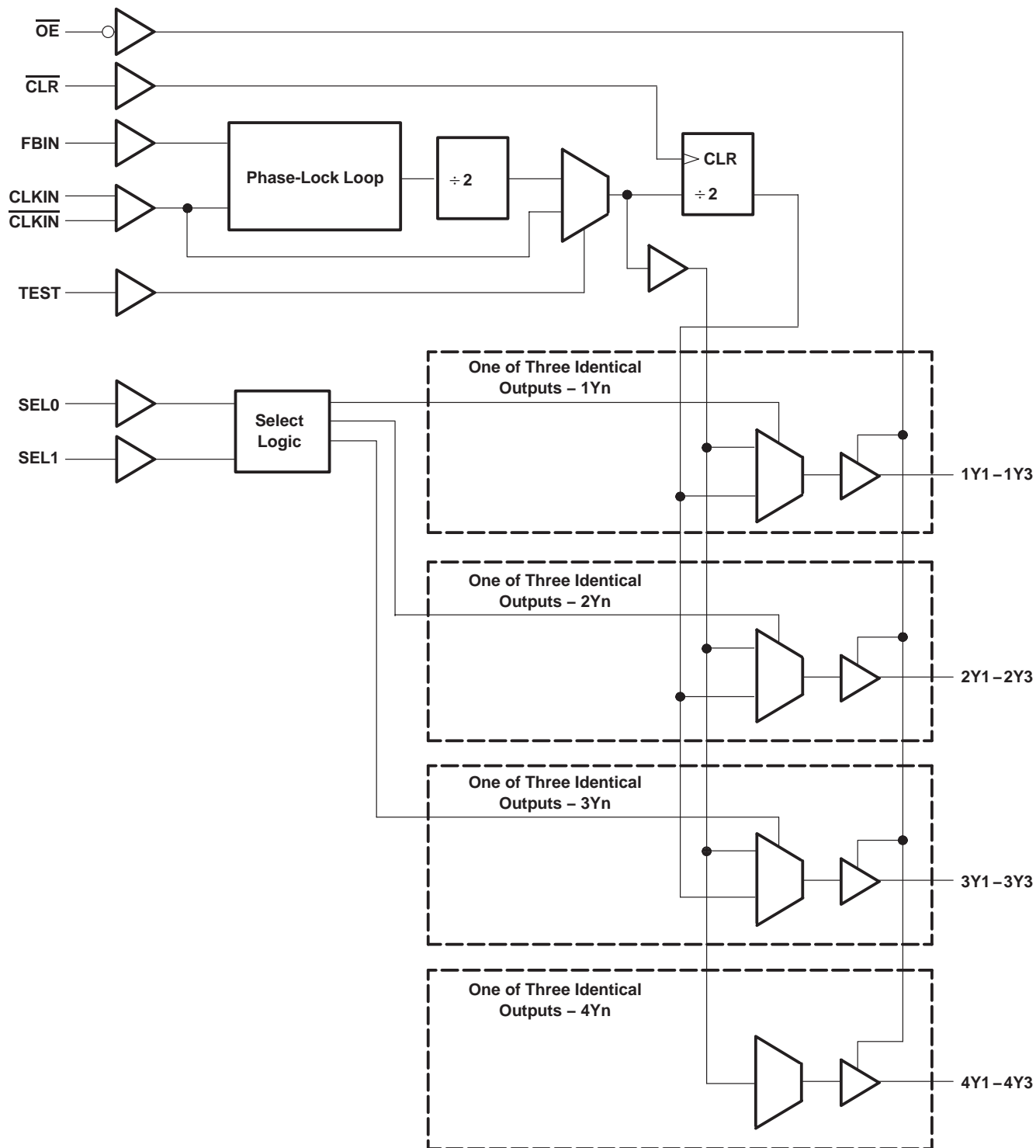

CDC582
3.3-V PHASE-LOCK LOOP CLOCK DRIVER
WITH DIFFERENTIAL LVPECL CLOCK INPUTS

SCAS446B – JULY 1994 – REVISED FEBRUARY 1996

Terminal Functions

TERMINAL NAME	NO.	I/O	DESCRIPTION
$\overline{\text{CLKIN}}$ $\overline{\text{CLKIN}}$	44, 45	I	Clock input. CLKIN and $\overline{\text{CLKIN}}$ are the differential clock signals to be distributed by the CDC582 clock-driver circuit. These inputs are used to provide the reference signal to the integrated PLL that generates the clock output signals. CLKIN and $\overline{\text{CLKIN}}$ must have a fixed frequency and fixed phase for the PLL to obtain phase lock. Once the circuit is powered up and valid CLKIN and $\overline{\text{CLKIN}}$ signals are applied, a stabilization time is required for the PLL to phase lock the feedback signal to its reference signal.
$\overline{\text{CLR}}$	40	I	Clear. $\overline{\text{CLR}}$ is used to reset the VCO/4 reference frequency. $\overline{\text{CLR}}$ is negative-edge triggered and should be strapped to V_{CC} or GND for normal operation.
FBIN	48	I	Feedback input. FBIN provides the feedback signal to the internal PLL. FBIN must be hardwired to one of the twelve clock outputs to provide frequency and phase lock. The internal PLL adjusts the output clocks to obtain zero phase delay between the FBIN and the differential clock input (CLKIN and $\overline{\text{CLKIN}}$).
$\overline{\text{OE}}$	42	I	Output enable. $\overline{\text{OE}}$ is the output enable for all outputs. When $\overline{\text{OE}}$ is low, all outputs are enabled. When $\overline{\text{OE}}$ is high, all outputs are driven to the low state. Since the feedback signal for the PLL is taken directly from an output terminal, placing the outputs in the logic low state interrupts the feedback loop; therefore, when a high-to-low transition occurs at $\overline{\text{OE}}$, enabling the output buffers, a stabilization time is required before the PLL obtains phase lock.
SEL1, SEL0	51, 50	I	Output configuration select. SEL0 and SEL1 select the output configuration for each output bank (e.g., 1x, 1/2x, or 2x) (see Tables 1 and 2).
TEST	41	I	TEST is used to bypass the PLL circuitry for factory testing of the device. When TEST is low, all outputs operate using the PLL circuitry. When TEST is high, the outputs are placed in a test mode that bypasses the PLL circuitry. TEST should be strapped to GND for normal operation.
1Y1–1Y3 2Y1–2Y3 3Y1–3Y3	2, 5, 8 12, 15, 18 22, 25, 28	O	These outputs are configured by SEL1 and SEL0 to transmit one-half or one-fourth the frequency of the VCO. The relationship between the input clock frequency and the output frequency is dependent on SEL1 and SEL0 and the frequency of the output being fed back to FBIN. The duty cycle of the Y outputs is nominally 50% independent of the duty cycle of the input clock signals.
4Y1–4Y3	32, 35, 38	O	These outputs transmit one-half the frequency of the VCO. The relationship between the input clock frequency and the output frequency is dependent on the frequency of the output being fed back to FBIN. The duty cycle of the Y outputs is nominally 50% independent of the duty cycle of CLKIN.

absolute maximum ratings over operating free-air temperature range (unless otherwise noted)†

Supply voltage range, V_{CC}	–0.5 V to 4.6 V
Input voltage range, V_I (see Note 1)	–0.5 V to 7 V
Voltage range applied to any output in the high state or power-off state, V_O (see Note 1)	–0.5 V to 5.5 V
Current into any output in the low state, I_O	64 mA
Input clamp current, I_{IK} ($V_I < 0$)	–20 mA
Output clamp current, I_{OK} ($V_O < 0$)	–50 mA
Maximum power dissipation at $T_A = 55^\circ\text{C}$ (in still air) (see Note 2)	1.2 W
Storage temperature range, T_{stg}	–65°C to 150°C

† Stresses beyond those listed under “absolute maximum ratings” may cause permanent damage to the device. These are stress ratings only, and functional operation of the device at these or any other conditions beyond those indicated under “recommended operating conditions” is not implied. Exposure to absolute-maximum-rated conditions for extended periods may affect device reliability.

- NOTES: 1. The input and output negative-voltage ratings may be exceeded if the input and output clamp-current ratings are observed.
2. The maximum package power dissipation is calculated using a junction temperature of 150°C and a board trace length of 750 mils. For more information, refer to the *Package Thermal Considerations* application note in the *ABT Advanced BiCMOS Technology Data Book*, literature number SCBD002.



CDC582
3.3-V PHASE-LOCK LOOP CLOCK DRIVER
WITH DIFFERENTIAL LVPECL CLOCK INPUTS

SCAS446B – JULY 1994 – REVISED FEBRUARY 1996

recommended operating conditions (see Note 3)

		MIN	MAX	UNIT
V _{CC}	Supply voltage	3	3.6	V
V _{IH}	High-level input voltage	CLKIN, $\overline{\text{CLKIN}}$	V _{CC} - 1.025	V
		Other inputs	2	
V _{IL}	Low-level input voltage	CLKIN, $\overline{\text{CLKIN}}$	V _{CC} - 1.62	V
		Other inputs	0.8	
V _I	Input voltage	0	5.5	V
I _{OH}	High-level output current		-32	mA
I _{OL}	Low-level output current		32	mA
T _A	Operating free-air temperature	0	70	°C

NOTE 3: Unused inputs must be held high or low to prevent them from floating.

electrical characteristics over recommended operating free-air temperature range (unless otherwise noted)

PARAMETER	TEST CONDITIONS		T _A = 25°C		UNIT
			MIN	MAX	
V _{IK}	V _{CC} = 3 V,	I _I = -18 mA		-1.2	V
V _{OH}	V _{CC} = MIN to MAX [†] ,	I _{OH} = -100 μA	V _{CC} - 0.2		V
	V _{CC} = 3 V,	I _{OH} = -32 mA	2		
V _{OL}	V _{CC} = 3 V	I _{OL} = 100 μA	0.2		V
		I _{OL} = 32 mA	0.5		
I _I	V _{CC} = 0 or MAX [†] ,	V _I = 3.6 V	±10		μA
	V _{CC} = 3.6 V,	V _I = V _{CC} or GND	±1		
I _{CC}	V _{CC} = 3.6 V, V _I = V _{CC} or GND	I _O = 0,	Outputs high	5	mA
			Outputs low	5	
C _i	V _I = 3 V or 0		4		pF
C _o	V _O = 3 V or 0		8		pF

[†] For conditions shown as MIN or MAX, use the appropriate value specified under recommended operating conditions.



CDC582

3.3-V PHASE-LOCK LOOP CLOCK DRIVER WITH DIFFERENTIAL LVPECL CLOCK INPUTS

SCAS446B – JULY 1994 – REVISED FEBRUARY 1996

timing requirements over recommended ranges of supply voltage and operating free-air temperature

		MIN	MAX	UNIT
f_{clock}	Clock frequency	VCO is operating at four times the CLKIN/CLKIN frequency		MHz
		VCO is operating at double the CLKIN/CLKIN frequency		
Input clock duty cycle		40%	60%	
Stabilization time [†]	After SEL1, SEL0			μs
	After $\overline{\text{OE}}\downarrow$			
	After power up			

[†] Time required for the integrated PLL circuit to obtain phase lock of its feedback signal to its reference signal. For phase lock to be obtained, a fixed-frequency, fixed-phase reference signal must be present at CLKIN. Until phase lock is obtained, the specifications for propagation delay and skew parameters given in the switching characteristics table are not applicable.

switching characteristics over recommended ranges of supply voltage and operating free-air temperature, $C_L = 15 \text{ pF}$ (see Note 4 and Figures 1, 2, and 3)

PARAMETER	FROM (INPUT)	TO (OUTPUT)	MIN	MAX	UNIT
Duty cycle		Y	45%	55%	
f_{max}			100		MHz
Jitter(pk-pk)	CLKIN \uparrow	Y \uparrow		200	ps
$t_{\text{phase error}}^{\ddagger}$	CLKIN \uparrow	Y \uparrow	-500	500	ps
$t_{\text{sk(o)}}^{\ddagger}$		Y		0.5	ns
$t_{\text{sk(pr)}}^{\ddagger}$		Y		1	ns
t_r				1.4	ns
t_f				1.4	ns

[‡] The propagation delay, $t_{\text{phase error}}$, is dependent on the feedback path from any output to the FBIN. The $t_{\text{phase error}}$, $t_{\text{sk(o)}}$, and $t_{\text{sk(pr)}}$ specifications are only valid for equal loading of all outputs.

NOTE 4: The specifications for parameters in this table are applicable only after any appropriate stabilization time has elapsed.

PARAMETER MEASUREMENT INFORMATION

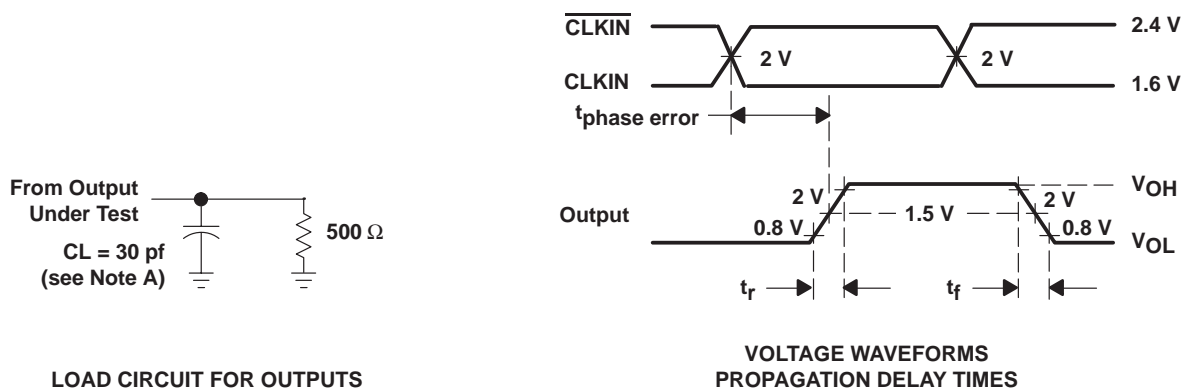

- NOTES: A. C_L includes probe and jig capacitance.
 B. The outputs are measured one at a time with one transition per measurement.
 C. All input pulses are supplied by generators having the following characteristics: PRR $\leq 10 \text{ MHz}$, $Z_O = 50 \Omega$, $t_r \leq 2.5 \text{ ns}$, $t_f \leq 2.5 \text{ ns}$.

Figure 1. Load Circuit and Voltage Waveforms



CDC582
3.3-V PHASE-LOCK LOOP CLOCK DRIVER
WITH DIFFERENTIAL LVPECL CLOCK INPUTS

SCAS446B – JULY 1994 – REVISED FEBRUARY 1996

PARAMETER MEASUREMENT INFORMATION

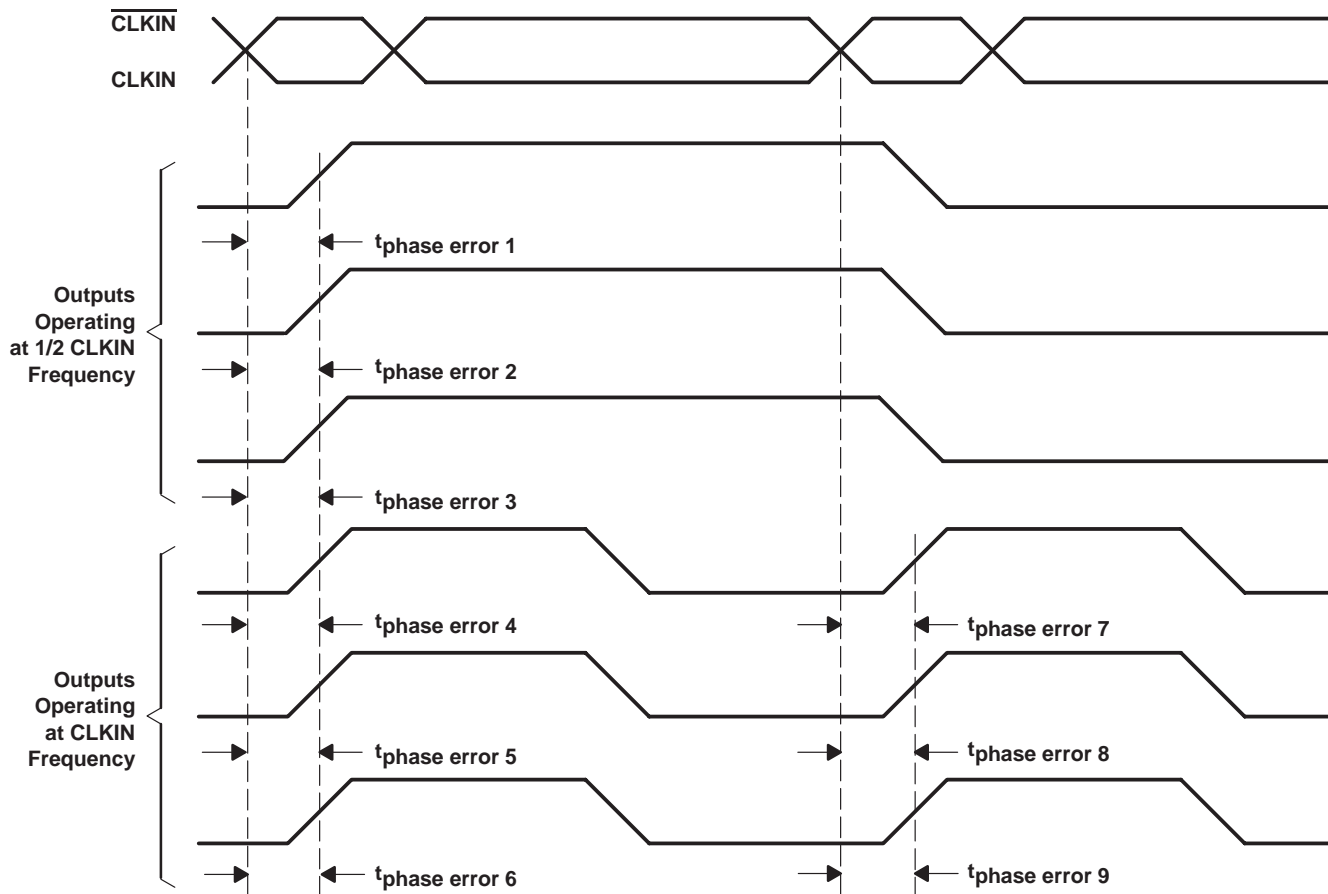

- NOTES: A. Output skew, $t_{sk(o)}$, is calculated as the greater of:
- The difference between the fastest and slowest of $t_{phase\ error\ n}$ ($n = 1, 2, \dots 6$)
 - The difference between the fastest and slowest of $t_{phase\ error\ n}$ ($n = 7, 8, 9$)
- B. Process skew, $t_{sk(pr)}$, is calculated as the greater of:
- The difference between the maximum and minimum $t_{phase\ error\ n}$ ($n = 1, 2, \dots 6$) across multiple devices under identical operating conditions
 - The difference between the maximum and minimum $t_{phase\ error\ n}$ ($n = 7, 8, 9$) across multiple devices under identical operating conditions

Figure 2. Skew Waveforms and Calculations



PARAMETER MEASUREMENT INFORMATION

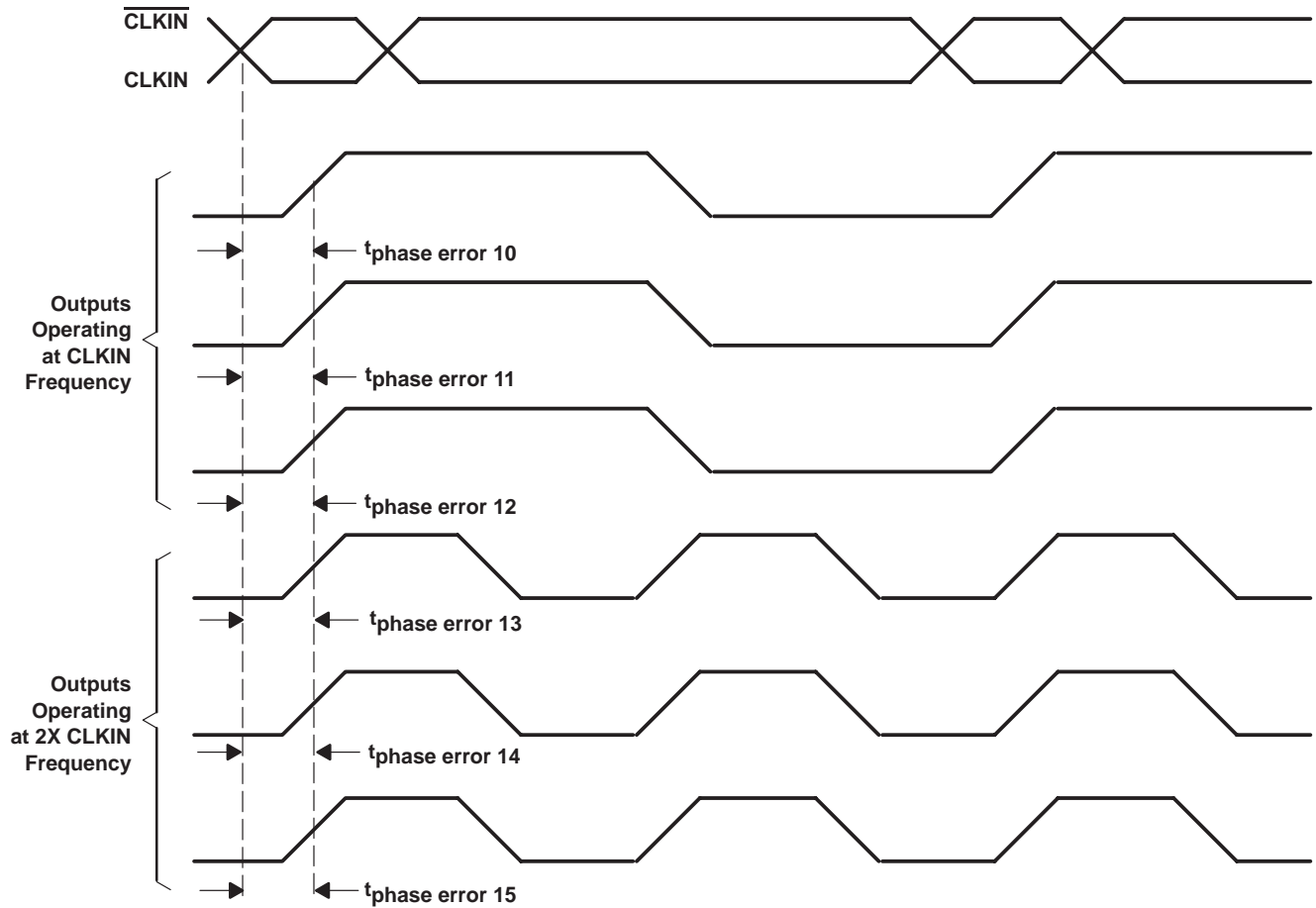

- NOTES: A. Output skew, $t_{\text{sk}(o)}$, is calculated as the greater of:
- The difference between the fastest and slowest of $t_{\text{phase error } n}$ ($n = 10, 11, \dots, 15$)
- B. Process skew, $t_{\text{sk}(pr)}$, is calculated as the greater of:
- The difference between the maximum and minimum $t_{\text{phase error } n}$ ($n = 10, 11, \dots, 15$) across multiple devices under identical operating conditions

Figure 3. Waveforms for Calculation of $t_{\text{sk}(o)}$

IMPORTANT NOTICE

Texas Instruments Incorporated and its subsidiaries (TI) reserve the right to make corrections, modifications, enhancements, improvements, and other changes to its products and services at any time and to discontinue any product or service without notice. Customers should obtain the latest relevant information before placing orders and should verify that such information is current and complete. All products are sold subject to TI's terms and conditions of sale supplied at the time of order acknowledgment.

TI warrants performance of its hardware products to the specifications applicable at the time of sale in accordance with TI's standard warranty. Testing and other quality control techniques are used to the extent TI deems necessary to support this warranty. Except where mandated by government requirements, testing of all parameters of each product is not necessarily performed.

TI assumes no liability for applications assistance or customer product design. Customers are responsible for their products and applications using TI components. To minimize the risks associated with customer products and applications, customers should provide adequate design and operating safeguards.

TI does not warrant or represent that any license, either express or implied, is granted under any TI patent right, copyright, mask work right, or other TI intellectual property right relating to any combination, machine, or process in which TI products or services are used. Information published by TI regarding third-party products or services does not constitute a license from TI to use such products or services or a warranty or endorsement thereof. Use of such information may require a license from a third party under the patents or other intellectual property of the third party, or a license from TI under the patents or other intellectual property of TI.

Reproduction of TI information in TI data books or data sheets is permissible only if reproduction is without alteration and is accompanied by all associated warranties, conditions, limitations, and notices. Reproduction of this information with alteration is an unfair and deceptive business practice. TI is not responsible or liable for such altered documentation. Information of third parties may be subject to additional restrictions.

Resale of TI products or services with statements different from or beyond the parameters stated by TI for that product or service voids all express and any implied warranties for the associated TI product or service and is an unfair and deceptive business practice. TI is not responsible or liable for any such statements.

TI products are not authorized for use in safety-critical applications (such as life support) where a failure of the TI product would reasonably be expected to cause severe personal injury or death, unless officers of the parties have executed an agreement specifically governing such use. Buyers represent that they have all necessary expertise in the safety and regulatory ramifications of their applications, and acknowledge and agree that they are solely responsible for all legal, regulatory and safety-related requirements concerning their products and any use of TI products in such safety-critical applications, notwithstanding any applications-related information or support that may be provided by TI. Further, Buyers must fully indemnify TI and its representatives against any damages arising out of the use of TI products in such safety-critical applications.

TI products are neither designed nor intended for use in military/aerospace applications or environments unless the TI products are specifically designated by TI as military-grade or "enhanced plastic." Only products designated by TI as military-grade meet military specifications. Buyers acknowledge and agree that any such use of TI products which TI has not designated as military-grade is solely at the Buyer's risk, and that they are solely responsible for compliance with all legal and regulatory requirements in connection with such use.

TI products are neither designed nor intended for use in automotive applications or environments unless the specific TI products are designated by TI as compliant with ISO/TS 16949 requirements. Buyers acknowledge and agree that, if they use any non-designated products in automotive applications, TI will not be responsible for any failure to meet such requirements.

Following are URLs where you can obtain information on other Texas Instruments products and application solutions:

Products

Amplifiers	amplifier.ti.com
Data Converters	dataconverter.ti.com
DLP® Products	www.dlp.com
DSP	dsp.ti.com
Clocks and Timers	www.ti.com/clocks
Interface	interface.ti.com
Logic	logic.ti.com
Power Mgmt	power.ti.com
Microcontrollers	microcontroller.ti.com
RFID	www.ti-rfid.com
RF/IF and ZigBee® Solutions	www.ti.com/lprf

Applications

Audio	www.ti.com/audio
Automotive	www.ti.com/automotive
Broadband	www.ti.com/broadband
Digital Control	www.ti.com/digitalcontrol
Medical	www.ti.com/medical
Military	www.ti.com/military
Optical Networking	www.ti.com/opticalnetwork
Security	www.ti.com/security
Telephony	www.ti.com/telephony
Video & Imaging	www.ti.com/video
Wireless	www.ti.com/wireless

Mailing Address: Texas Instruments, Post Office Box 655303, Dallas, Texas 75265
Copyright © 2009, Texas Instruments Incorporated

Looking for pricing, stock, or lifecycle information?

Click below to explore more details on WIN SOURCE:

 [View CDC582PAH](#) on WIN SOURCE

 [Texas Instruments](#) Information

Optimize Your Supply Chain with WIN SOURCE Solutions

-  Global Sourcing Solution
-  Obsolete Management
-  Cost Control Management
-  Shortage Management
-  Alternative Solution
-  Excess Inventory Management