



**THE DATASHEET OF
SN74HC4066DRG4**



SN74HC4066 quadruple bilateral analog switch

1 Features

- Wide Operating Voltage Range of 2 V to 6 V
- Typical Switch Enable Time of 18 ns
- Low Power Consumption, 20- μ A Maximum I_{CC}
- Low Input Current of 1 μ A Maximum
- High Degree of Linearity
- High On-Off Output-Voltage Ratio
- Low Crosstalk Between Switches
- Low On-State Impedance: 50- Ω Typical at $V_{CC} = 6$ V
- Individual Switch Controls

2 Applications

- Analog Signal Switching/Multiplexing:
 - Signal Gating, Modulator, Squelch Control, Demodulator, Chopper, Commutating Switch
- Digital Signal Switching/Multiplexing
 - Audio and Video Signal Routing
- Transmission-Gate Logic Implementation
- Analog-to-Digital and Digital-to-Analog Conversion
- Digital Control of Frequency, Impedance, Phase, and Analog-Signal Gain
- Motor Speed Control
- Battery Chargers
- DC-DC Converter

3 Description

The SN74HC4066 device is a silicon-gate CMOS quadruple analog switch designed to handle both analog and digital signals. Each switch permits signals with amplitudes of up to 6 V (peak) to be transmitted in either direction.

Each switch section has its own enable input control (C). A high-level voltage applied to C turns on the associated switch section.

Applications include signal gating, chopping, modulation or demodulation (modem), and signal multiplexing for analog-to-digital and digital-to-analog conversion systems.

Device Information⁽¹⁾

PART NUMBER	PACKAGE (PINS)	BODY SIZE (NOM)
SN74HC4066D	SOIC (14)	8.65 mm x 3.91 mm
SN74HC4066DB	SSOP (14)	6.20 mm x 5.30 mm
SN74HC4066PW	TSSOP (14)	5.00 mm x 4.40 mm
SN74HC4066N	PDIP (14)	19.30 mm x 6.35 mm
SN74HC4066NS	SO (14)	10.30 mm x 5.30 mm

(1) For all available packages, see the orderable addendum at the end of the data sheet.

Logic Diagram, Each Switch (Positive Logic)

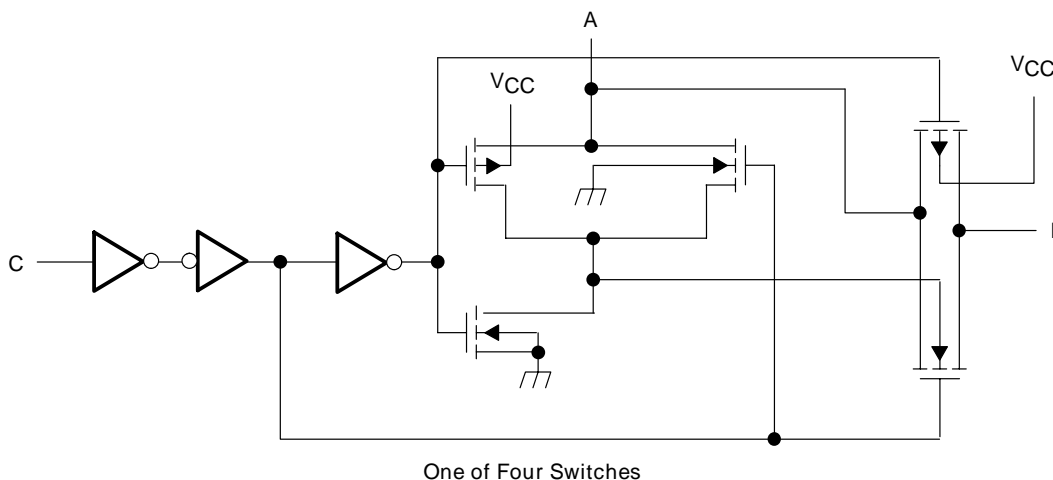

Copyright © 2016, Texas Instruments Incorporated



Table of Contents

1 Features	1	8.3 Feature Description	13
2 Applications	1	8.4 Device Functional Modes	13
3 Description	1	9 Application and Implementation	14
4 Revision History	2	9.1 Application Information	14
5 Pin Configuration and Functions	3	9.2 Typical Application	14
6 Specifications	4	10 Power Supply Recommendations	16
6.1 Absolute Maximum Ratings	4	11 Layout	16
6.2 ESD Ratings	4	11.1 Layout Guidelines	16
6.3 Recommended Operating Conditions	4	11.2 Layout Example	16
6.4 Thermal Information	5	12 Device and Documentation Support	17
6.5 Electrical Characteristics	5	12.1 Documentation Support	17
6.6 Switching Characteristics	6	12.2 Receiving Notification of Documentation Updates	17
6.7 Operating Characteristics	6	12.3 Community Resource	17
6.8 Typical Characteristics	7	12.4 Trademarks	17
7 Parameter Measurement Information	8	12.5 Electrostatic Discharge Caution	17
8 Detailed Description	13	12.6 Glossary	17
8.1 Overview	13	13 Mechanical, Packaging, and Orderable Information	17
8.2 Functional Block Diagram	13		

4 Revision History

NOTE: Page numbers for previous revisions may differ from page numbers in the current version.

Changes from Revision I (January 2019) to Revision J	Page
• Changed the MAX values for I_{soff} , I_{son} , and I_{CC} in the <i>Electrical Characteristics</i> table	5

Changes from Revision H (August 2016) to Revision I	Page
• Changed the Description of pins 8 through 12 in the <i>Pin Functions</i> table	3

Changes from Revision G (July 2003) to Revision H	Page
• Added <i>ESD Ratings</i> table, <i>Feature Description</i> section, <i>Device Functional Modes</i> , <i>Application and Implementation</i> section, <i>Power Supply Recommendations</i> section, <i>Layout</i> section, <i>Device and Documentation Support</i> section, and <i>Mechanical, Packaging, and Orderable Information</i> section	1
• Deleted <i>Ordering Information</i> table, see POA at the end of the datasheet	1

5 Pin Configuration and Functions

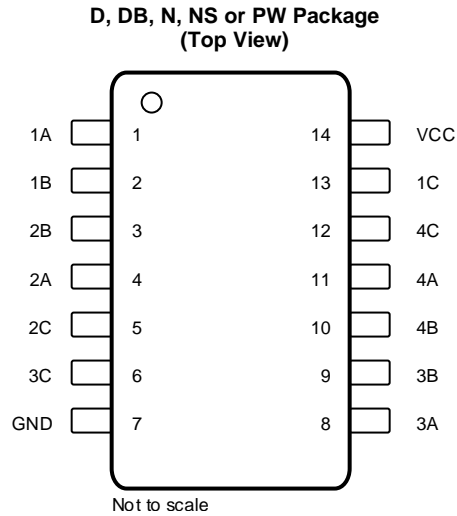

Pin Functions

PIN		I/O	DESCRIPTION
NO.	NAME		
1	1A	I/O	Switch 1 input/output
2	1B	I/O	Switch 1 output/input
3	2B	I/O	Switch 2 output/input
4	2A	I/O	Switch 2 input/output
5	2C	I	Switch 2 control
6	3C	I	Switch 3 control
7	GND	—	Ground
8	3A	I/O	Switch 3 input/output
9	3B	I/O	Switch 3 output/input
10	4B	I/O	Switch 4 output/input
11	4A	I/O	Switch 4 input/output
12	4C	I	Switch 4 control
13	1C	I	Switch 1 control
14	V _{CC}	—	Power

6 Specifications

6.1 Absolute Maximum Ratings

over operating free-air temperature range (unless otherwise noted)⁽¹⁾

			MIN	MAX	UNIT
V_{CC}	Supply voltage ⁽²⁾		-0.5	7	V
I_I	Control-input diode current	$V_I < 0$ or $V_I > V_{CC}$		± 20	mA
I_I	I/O port diode current	$V_I < 0$ or $V_{I/O} > V_{CC}$		± 20	mA
	On-state switch current	$V_{I/O} = 0$ to V_{CC}		± 25	mA
	Continuous current through V_{CC} or GND			± 50	mA
T_J	Junction temperature			150	°C
T_{stg}	Storage temperature		-60	150	°C

- (1) Stresses beyond those listed under *Absolute Maximum Ratings* may cause permanent damage to the device. These are stress ratings only, which do not imply functional operation of the device at these or any other conditions beyond those indicated under *Recommended Operating Conditions*. Exposure to absolute-maximum-rated conditions for extended periods may affect device reliability.
- (2) All voltages are with respect to ground unless otherwise specified.

6.2 ESD Ratings

			VALUE	UNIT
$V_{(ESD)}$	Electrostatic discharge	Human-body model (HBM), per ANSI/ESDA/JEDEC JS-001 ⁽¹⁾	± 1000	V
		Charged-device model (CDM), per JEDEC specification JESD22-C101 ⁽²⁾	± 1000	

- (1) JEDEC document JEP155 states that 500-V HBM allows safe manufacturing with a standard ESD control process.
- (2) JEDEC document JEP157 states that 250-V CDM allows safe manufacturing with a standard ESD control process. CDM value for N package only.

6.3 Recommended Operating Conditions

over operating free-air temperature range (unless otherwise noted)⁽¹⁾

			MIN	NOM	MAX	UNIT
V_{CC}	Supply voltage		2 ⁽²⁾	5	6	V
$V_{I/O}$	I/O port voltage		0		V_{CC}	V
V_{IH}	High-level input voltage, control inputs	$V_{CC} = 2$ V	1.5		V_{CC}	V
		$V_{CC} = 4.5$ V	3.15		V_{CC}	
		$V_{CC} = 6$ V	4.2		V_{CC}	
V_{IL}	Low-level input voltage, control inputs	$V_{CC} = 2$ V	0		0.3	V
		$V_{CC} = 4.5$ V	0		0.9	
		$V_{CC} = 6$ V	0		1.2	
$\Delta t/\Delta v$	Input transition rise and fall time	$V_{CC} = 2$ V			1000	ns
		$V_{CC} = 4.5$ V			500	
		$V_{CC} = 6$ V			400	
T_A	Operating free-air temperature		-40		85	°C

- (1) All unused inputs of the device must be held at V_{CC} or GND to ensure proper device operation. See the TI application report, *Implications of Slow or Floating CMOS Inputs* (SCBA004).
- (2) With supply voltages at or near 2 V, the analog switch on-state resistance becomes very nonlinear. It is recommended that only digital signals be transmitted at these low supply voltages.

6.4 Thermal Information

THERMAL METRIC ⁽¹⁾	SN74HC4066					UNIT	
	D (SOIC)	DB (SSOP)	N (PDIP)	NS (SO)	PW (TSSOP)		
	14 PINS	14 PINS	14 PINS	14 PINS	14 PINS		
$R_{\theta JA}$	Junction-to-ambient thermal resistance	89.4	103.6	53.2	87.6	118.5	°C/W
$R_{\theta JC(top)}$	Junction-to-case (top) thermal resistance	49.5	55.6	40.5	45.4	47.3	°C/W
$R_{\theta JB}$	Junction-to-board thermal resistance	43.6	50.8	33.1	46.3	60.2	°C/W
Ψ_{JT}	Junction-to-top characterization parameter	17.2	21	25.3	15.8	5.2	°C/W
Ψ_{JB}	Junction-to-board characterization parameter	43.4	50.3	33	46	59.6	°C/W

(1) For more information about traditional and new thermal metrics, see the [Semiconductor and IC Package Thermal Metrics](#) application report.

6.5 Electrical Characteristics

$T_A = -40$ to $+85$ °C unless otherwise specified.

PARAMETER		TEST CONDITIONS	V_{CC}	MIN	TYP	MAX	UNIT
r_{on}	On-state switch resistance	$I_T = -1$ mA, $V_I = 0$ to V_{CC} , $V_C = V_{IH}$ (see Figure 2)	$T_A = 25$ C	2 V	150		Ω
			$T_A = 25$ C	4.5 V	50	85	
			$T_A = -40$ to $+85$		106		
			$T_A = 25$ C	6 V	30		
$r_{on(p)}$	Peak on-state resistance	$V_I = V_{CC}$ or GND, $V_C = V_{IH}$, $I_T = -1$ mA	$T_A = 25$ C	2 V	320		Ω
			$T_A = 25$ C	4.5 V	70	170	
			$T_A = -40$ to $+85$		215		
			$T_A = 25$ C	6 V	50		
I_I	Control input current	$V_C = 0$ or V_{CC}	$T_A = -40$ to $+85$	6 V	± 0.1	± 100	nA
			$T_A = 25$ C		± 1000		
I_{soff}	Off-state switch leakage current	$V_I = V_{CC}$ or 0, $V_O = V_{CC}$ or 0, $V_C = V_{IL}$ (see Figure 3)	$T_A = -40$ to $+85$	6 V	± 5		μA
			$T_A = 25$ C		± 0.1		
I_{son}	On-state switch leakage current	$V_I = V_{CC}$ or 0, $V_C = V_{IH}$ (see Figure 4)	$T_A = -40$ to $+85$	6 V	± 5		μA
			$T_A = 25$ C		± 0.1		
I_{CC}	Supply current	$V_I = 0$ or V_{CC} , $I_O = 0$	$T_A = -40$ to $+85$	6 V	20		μA
			$T_A = 25$ C		2		
C_i	Input capacitance	A or B	$T_A = 25$ C	5 V	9		pF
		C	$T_A = -40$ to $+85$		3	10	
			$T_A = 25$ C		10		
C_f	Feed-through capacitance	A to B	$V_I = 0$		0.5		pF
C_o	Output capacitance	A or B		5 V	9		pF

6.6 Switching Characteristics

 $T_A = -40$ to $+85$ °C unless otherwise specified.

PARAMETER	FROM (INPUT)	TO (OUTPUT)	TEST CONDITIONS	V_{CC}	MIN	TYP	MAX	UNIT
t_{PLH} , t_{PHL} Propagation delay time	A or B	B or A	$C_L = 50$ pF (see Figure 5)	$T_A = 25^\circ\text{C}$	2 V	10	60	ns
				$T_A = -40$ to $+85$		75		
				$T_A = 25^\circ\text{C}$	4.5 V	4	12	
				$T_A = -40$ to $+85$		15		
				$T_A = 25^\circ\text{C}$	6 V	3	10	
$T_A = -40$ to $+85$	13							
t_{PZH} , t_{PZL} Switch turn-on time	C	A or B	$R_L = 1$ k Ω , $C_L = 50$ pF (see Figure 6)	$T_A = 25^\circ\text{C}$	2 V	70	180	ns
				$T_A = -40$ to $+85$		225		
				$T_A = 25^\circ\text{C}$	4.5 V	21	36	
				$T_A = -40$ to $+85$		45		
				$T_A = 25^\circ\text{C}$	6 V	18	31	
$T_A = -40$ to $+85$	38							
t_{PLZ} , t_{PHZ} Switch turn-off time	C	A or B	$R_L = 1$ k Ω , $C_L = 50$ pF (see Figure 6)	$T_A = 25^\circ\text{C}$	2 V	50	200	ns
				$T_A = -40$ to $+85$		250		
				$T_A = 25^\circ\text{C}$	4.5 V	25	40	
				$T_A = -40$ to $+85$		50		
				$T_A = 25^\circ\text{C}$	6 V	22	34	
$T_A = -40$ to $+85$	43							
f_i Control input frequency	C	A or B	$C_L = 15$ pF, $R_L = 1$ k Ω , $V_C = V_{CC}$ or GND, $V_O = V_{CC} / 2$ (see Figure 7)	$T_A = 25^\circ\text{C}$	2 V	15	MHz	
				$T_A = 25^\circ\text{C}$	4.5 V	30		
				$T_A = 25^\circ\text{C}$	6 V	30		
Control feed-through noise	C	A or B	$C_L = 50$ pF, $R_{in} = R_L = 600$ Ω , $V_C = V_{CC}$ or GND, $f_{in} = 1$ MHz (see Figure 8)	$T_A = 25^\circ\text{C}$	4.5 V	15	mV (rms)	
				$T_A = 25^\circ\text{C}$	6 V	20		

6.7 Operating Characteristics

 $V_{CC} = 4.5$ V, $T_A = 25^\circ\text{C}$

PARAMETER	TEST CONDITIONS	TYP	UNIT
C_{pd} Power dissipation capacitance per gate	$C_L = 50$ pF, $f = 1$ MHz	45	pF
Minimum through bandwidth, A to B or B to A ⁽¹⁾ $[20 \log (V_O / V_i)] = -3$ dB	$C_L = 50$ pF, $R_L = 600$ Ω , $V_C = V_{CC}$ (see Figure 9)	30	MHz
Crosstalk between any switches ⁽²⁾	$C_L = 10$ pF, $R_L = 50$ Ω , $f_{in} = 1$ MHz (see Figure 10)	45	dB
Feed through, switch off, A to B or B to A ⁽²⁾	$C_L = 50$ pF, $R_L = 600$ Ω , $f_{in} = 1$ MHz (see Figure 11)	42	dB
Amplitude distortion rate, A to B or B to A	$C_L = 50$ pF, $R_L = 10$ k Ω , $f_{in} = 1$ kHz (see Figure 12)	0.05%	

(1) Adjust the input amplitude for output = 0 dBm at $f = 1$ MHz. Input signal must be a sine wave.

(2) Adjust the input amplitude for output = 0 dBm at $f = 1$ MHz. Input signal must be a sine wave.

6.8 Typical Characteristics

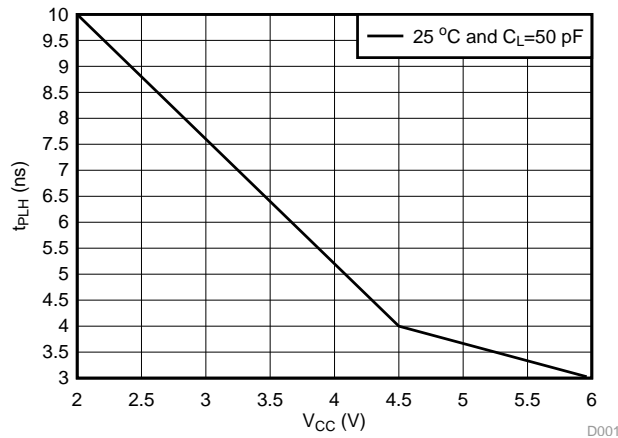

Figure 1. t_{PLH} vs V_{CC}

7 Parameter Measurement Information

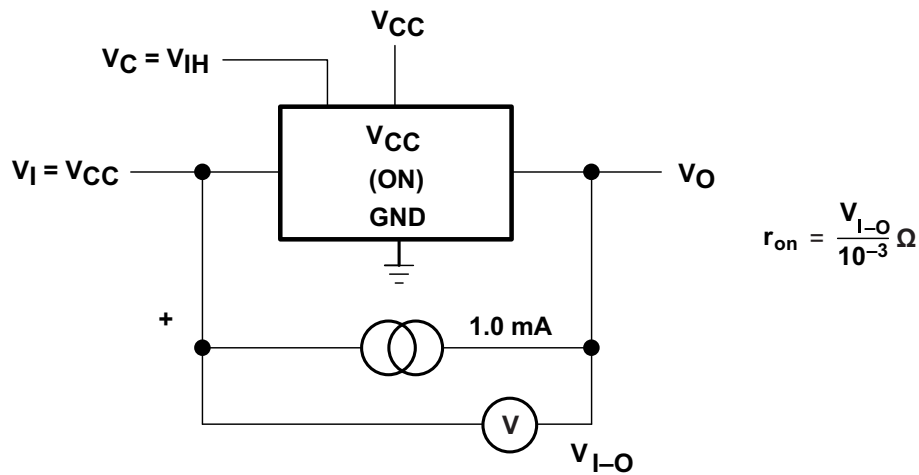
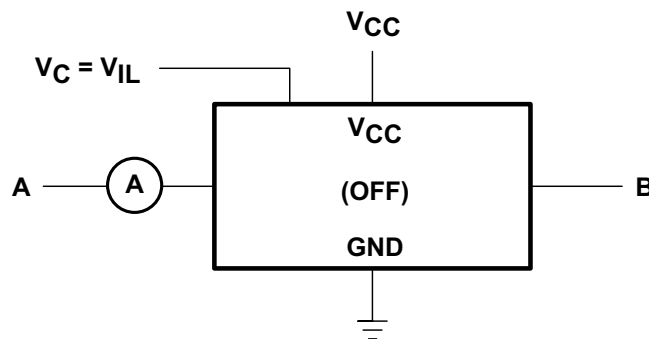

Figure 2. ON-State Resistance Test Circuit



$V_S = V_A - V_B$
 CONDITION 1: $V_A = 0, V_B = V_{CC}$
 CONDITION 2: $V_A = V_{CC}, V_B = 0$

Figure 3. OFF-State Switch Leakage-Current Test Circuit

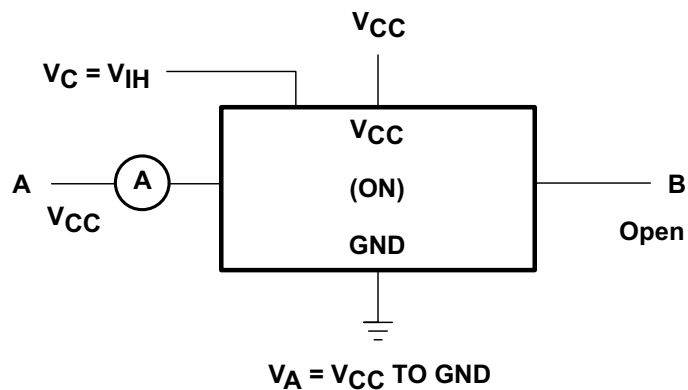

Figure 4. ON-State Leakage-Current Test Circuit

Parameter Measurement Information (continued)

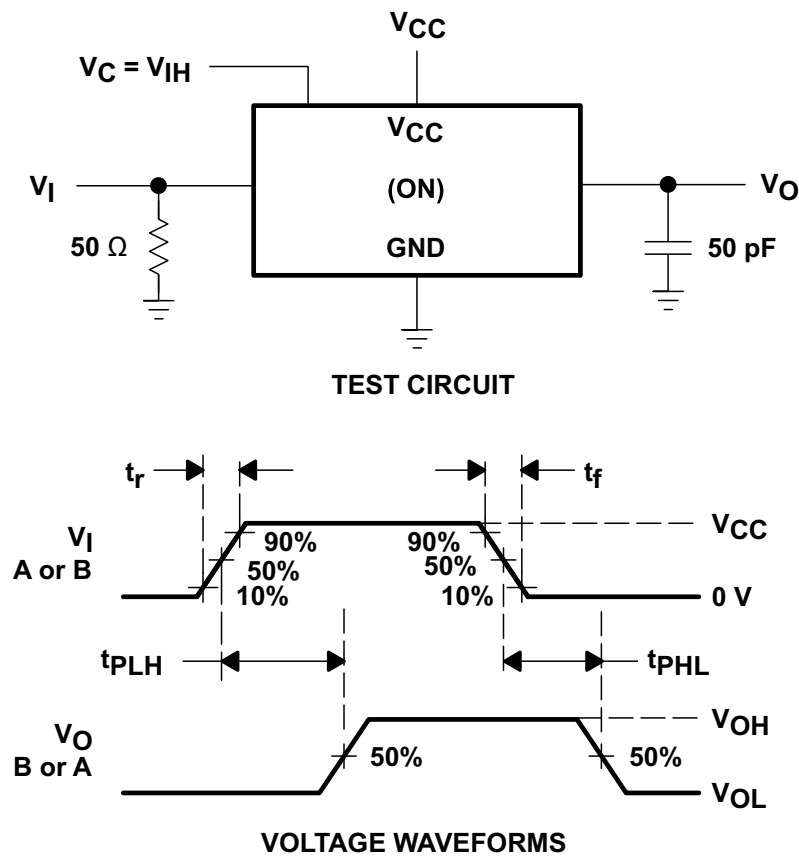

Figure 5. Propagation Delay Time, Signal Input to Signal Output

Parameter Measurement Information (continued)

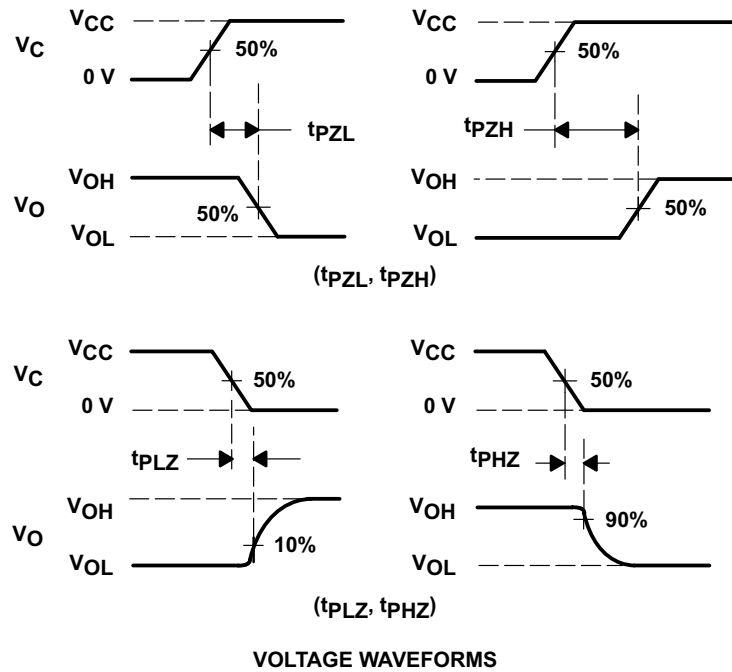
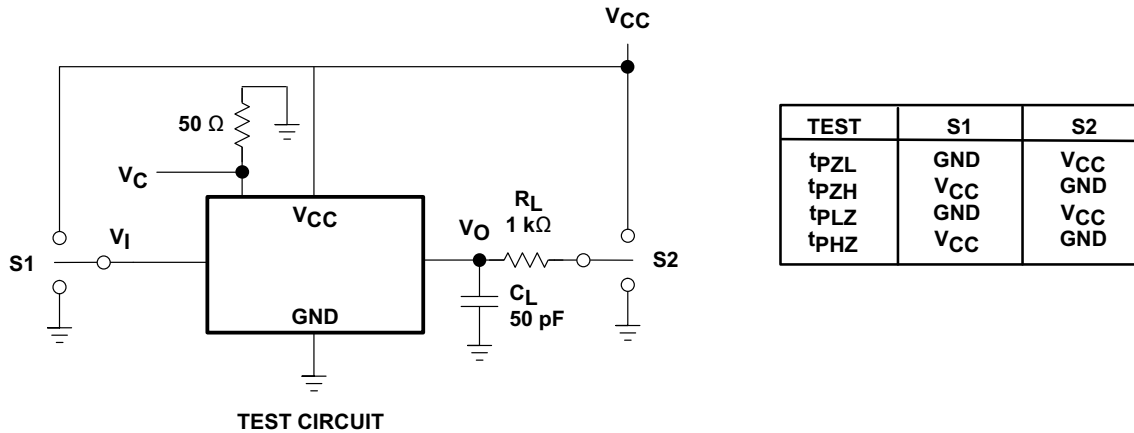
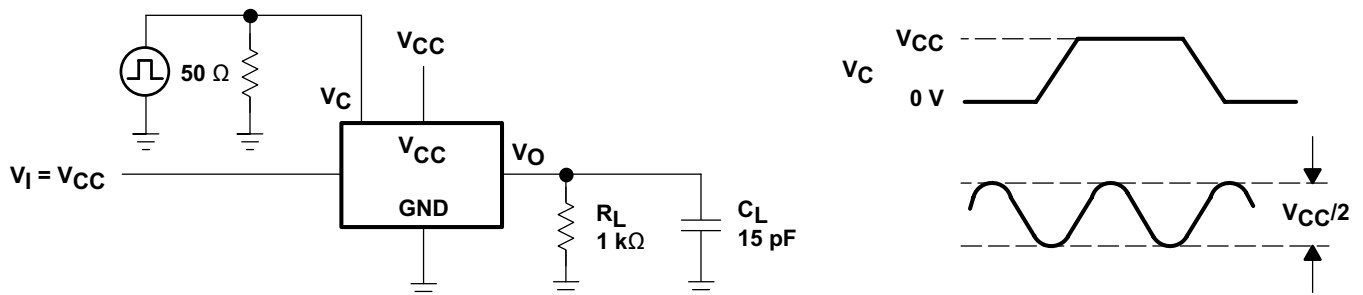

Figure 6. Switching Time (t_{PZL}, t_{PLZ}, t_{PZH}, t_{PHZ}), Control to Signal Output



Parameter Measurement Information (continued)

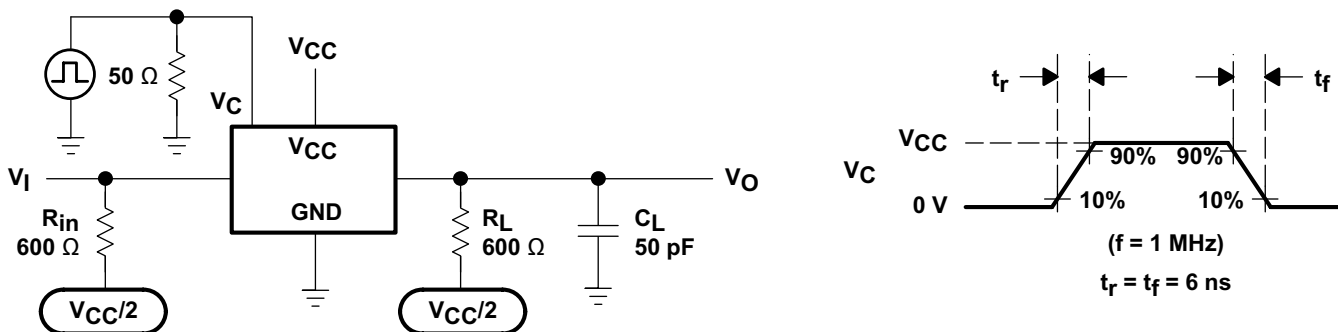

Figure 8. Control Feed-Through Noise

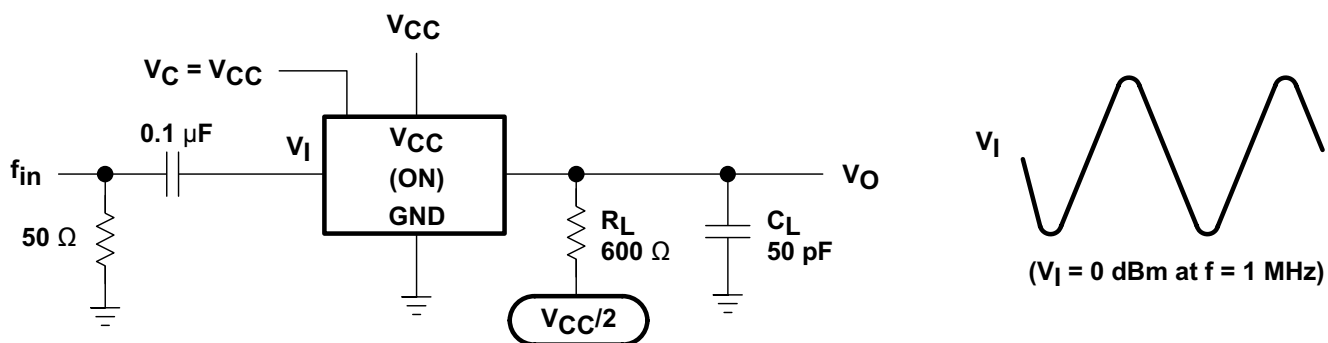

Figure 9. Minimum Through Bandwidth

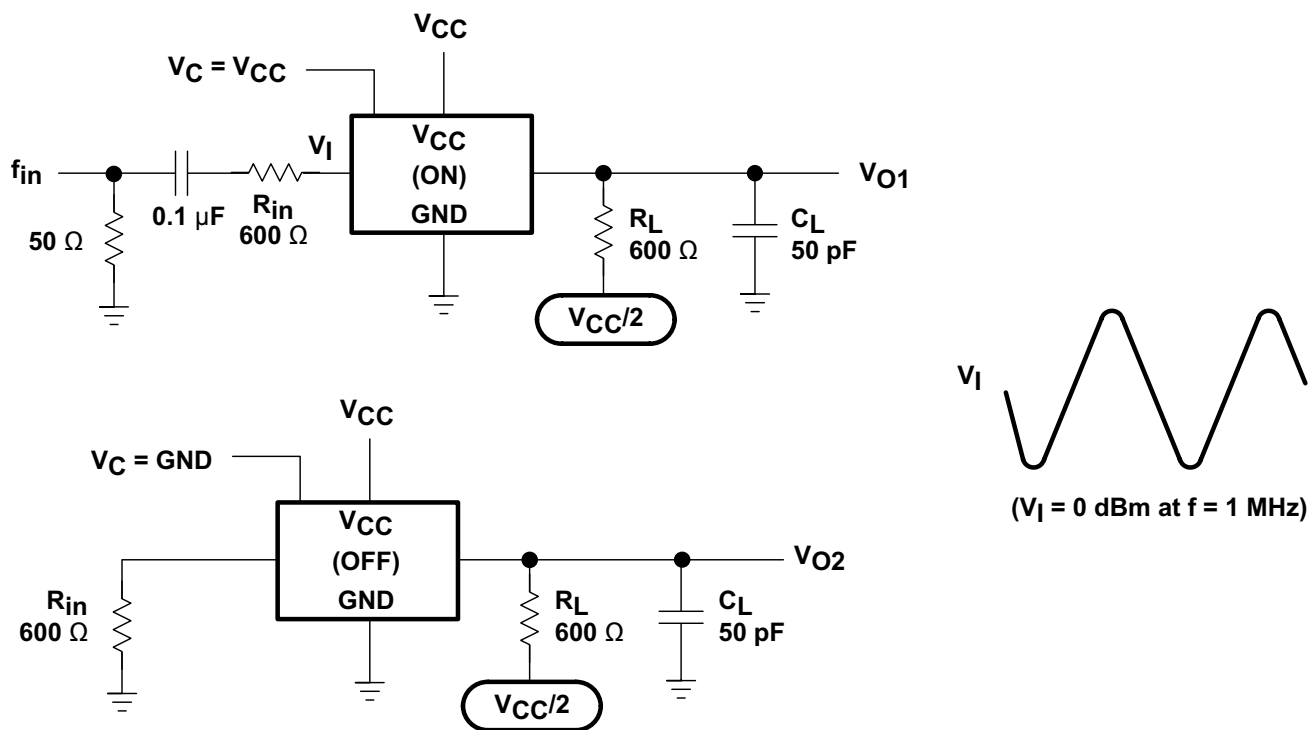

Figure 10. Crosstalk Between Any Two Switches

Parameter Measurement Information (continued)

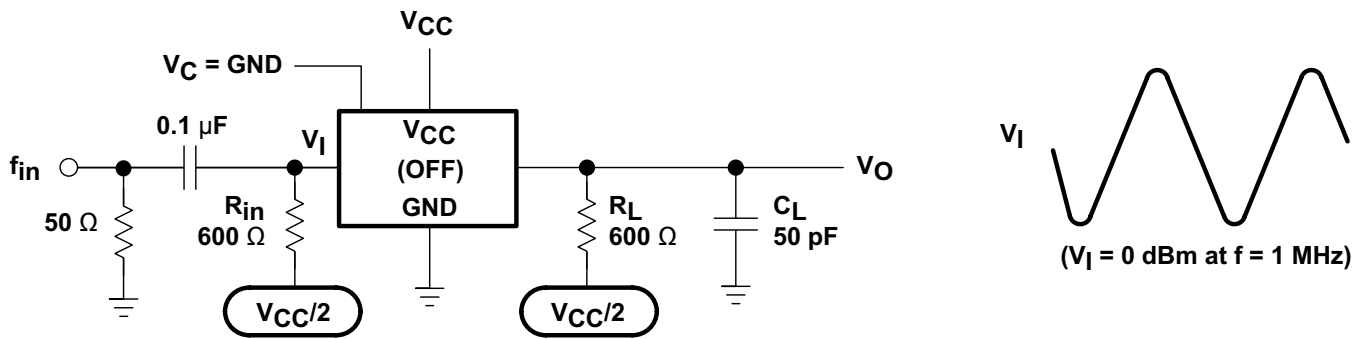

Figure 11. Feed Through, Switch OFF

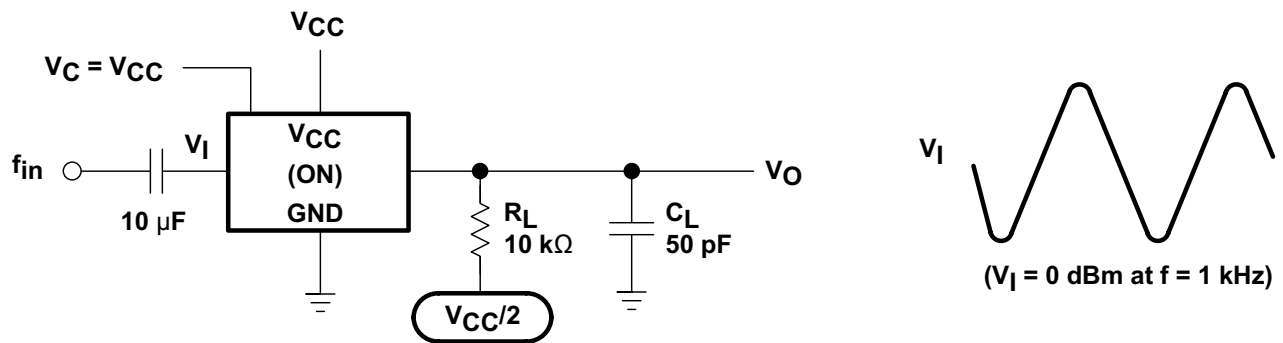

Figure 12. Amplitude-Distortion Rate

8 Detailed Description

8.1 Overview

The SN74HC4066 device is a silicon-gate CMOS quadruple analog switch designed for 2-V to 6-V VCC operation. It is designed to handle both analog and digital signals. Each switch permits signals with amplitudes of up to 6 V (peak) to be transmitted in either direction. A high-level voltage applied to the control pin C enables the respective switch to begin propagating signals across the device.

8.2 Functional Block Diagram

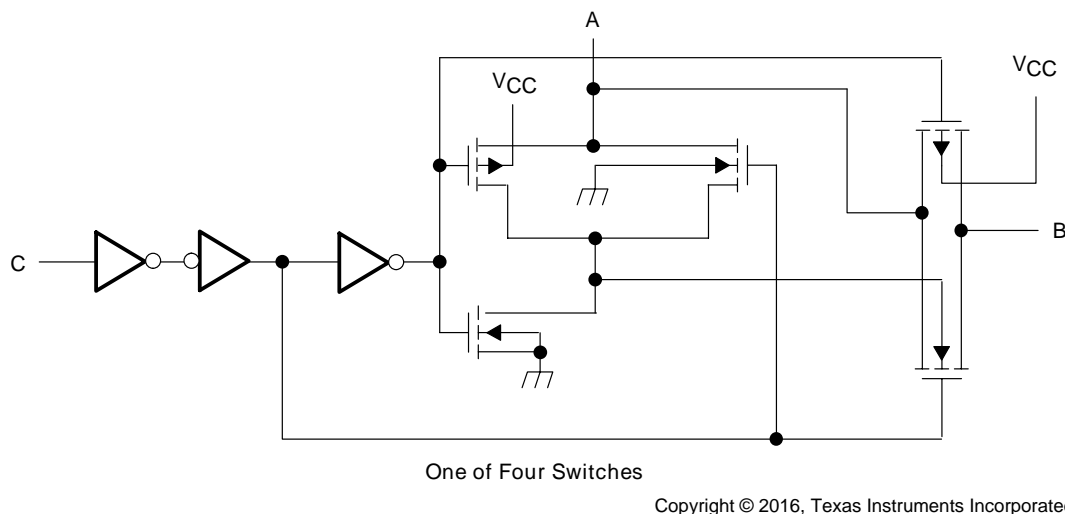

Figure 13. Logic Diagram, Each Switch (Positive Logic)

8.3 Feature Description

Each switch section has its own enable-input control (C). A high-level voltage applied to C turns on the associated switch section, with typically 18 ns of switch enable time. The SN74HC4066 has a wide operating voltage range of 2 V to 6 V. It has low power consumption, with 20- μ A maximum I_{CC} and a low on-state impedance of 50 Ω . It also has low crosstalk between switches to minimize noise.

8.4 Device Functional Modes

Table 1 lists the functions for the SN74HC4066 device.

Table 1. Function Table (Each Switch)

INPUT CONTROL (C)	SWITCH
L	OFF
H	ON

9 Application and Implementation

NOTE

Information in the following applications sections is not part of the TI component specification, and TI does not warrant its accuracy or completeness. TI's customers are responsible for determining suitability of components for their purposes. Customers should validate and test their design implementation to confirm system functionality.

9.1 Application Information

The SN74HC4066 can be used in any situation where an dual SPST switch would be used and a solid-state, voltage controlled version is preferred.

9.2 Typical Application

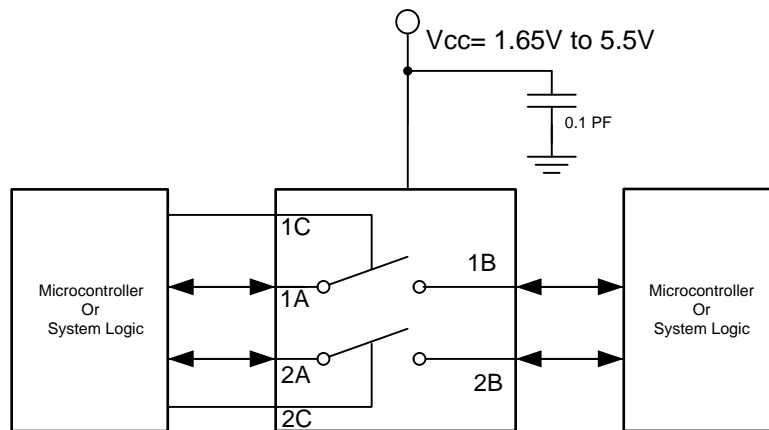

Copyright © 2016, Texas Instruments Incorporated

Figure 14. t_{PZH} vs V_{CC}

9.2.1 Design Requirements

The SN74HC4066 allows ON/OFF control of analog and digital signals with a digital control signal. All input signals should remain between 0 V and V_{CC} for optimal operation.

9.2.2 Detailed Design Procedure

1. Recommended Input Conditions:
 - For rise time and fall time specifications, see $\Delta t/\Delta v$ in [Recommended Operating Conditions](#).
 - For specified high and low levels, see V_{IH} and V_{IL} in [Recommended Operating Conditions](#).
2. Recommended Output Conditions:
 - On-state switch current should not exceed ± 25 mA.

Typical Application (continued)

9.2.3 Application Curve

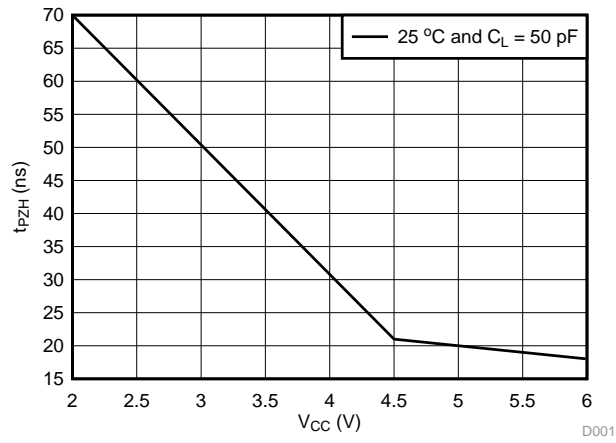

Figure 15. t_{pZH} vs V_{CC}

10 Power Supply Recommendations

The power supply can be any voltage between the minimum and maximum supply voltage rating located in the [Recommended Operating Conditions](#).

Each V_{CC} terminal should have a good bypass capacitor to prevent power disturbance. For devices with a single supply, TI recommends a 0.1- μF bypass capacitor. If there are multiple pins labeled V_{CC} , then a 0.01- μF or 0.022- μF capacitor is recommended for each V_{CC} because the VCC pins will be tied together internally. For devices with dual-supply pins operating at different voltages, for example V_{CC} and V_{DD} , TI recommends a 0.1- μF bypass capacitor for each supply pin. It is acceptable to parallel multiple bypass capacitors to reject different frequencies of noise. 0.1- μF and 1- μF capacitors are commonly used in parallel. The bypass capacitor should be installed as close to the power terminal as possible for best results.

11 Layout

11.1 Layout Guidelines

Reflections and matching are closely related to loop antenna theory, but different enough to warrant their own discussion. When a PCB trace turns a corner at a 90° angle, a reflection can occur. This is primarily due to the change of width of the trace. At the apex of the turn, the trace width is increased to 1.414 times its width. This upsets the transmission line characteristics, especially the distributed capacitance and self-inductance of the trace — resulting in the reflection.

NOTE

Not all PCB traces can be straight, and so they will have to turn corners. [Figure 16](#) shows progressively better techniques of rounding corners. Only the last example maintains constant trace width and minimizes reflections.

11.2 Layout Example

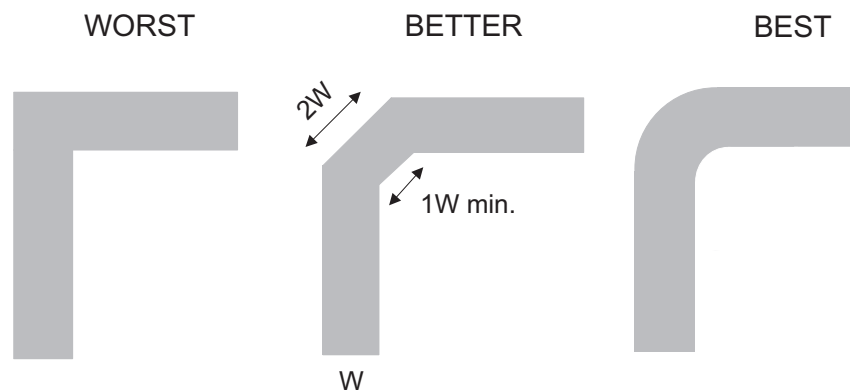

Figure 16. Trace Example

12 Device and Documentation Support

12.1 Documentation Support

12.1.1 Related Documentation

For related documentation see the following:

[Implications of Slow or Floating CMOS Inputs](#) (SCBA004)

12.2 Receiving Notification of Documentation Updates

To receive notification of documentation updates, navigate to the device product folder on ti.com. In the upper right corner, click on *Alert me* to register and receive a weekly digest of any product information that has changed. For change details, review the revision history included in any revised document.

12.3 Community Resource

The following links connect to TI community resources. Linked contents are provided "AS IS" by the respective contributors. They do not constitute TI specifications and do not necessarily reflect TI's views; see TI's [Terms of Use](#).

TI E2E™ Online Community *TI's Engineer-to-Engineer (E2E) Community*. Created to foster collaboration among engineers. At e2e.ti.com, you can ask questions, share knowledge, explore ideas and help solve problems with fellow engineers.

Design Support *TI's Design Support* Quickly find helpful E2E forums along with design support tools and contact information for technical support.

12.4 Trademarks

E2E is a trademark of Texas Instruments.
All other trademarks are the property of their respective owners.

12.5 Electrostatic Discharge Caution



These devices have limited built-in ESD protection. The leads should be shorted together or the device placed in conductive foam during storage or handling to prevent electrostatic damage to the MOS gates.

12.6 Glossary

[SLYZ022](#) — *TI Glossary*.

This glossary lists and explains terms, acronyms, and definitions.

13 Mechanical, Packaging, and Orderable Information

The following pages include mechanical, packaging, and orderable information. This information is the most current data available for the designated devices. This data is subject to change without notice and revision of this document. For browser-based versions of this data sheet, refer to the left-hand navigation.

PACKAGING INFORMATION

Orderable Device	Status (1)	Package Type	Package Drawing	Pins	Package Qty	Eco Plan (2)	Lead/Ball Finish (6)	MSL Peak Temp (3)	Op Temp (°C)	Device Marking (4/5)	Samples
SN74HC4066D	ACTIVE	SOIC	D	14	50	Green (RoHS & no Sb/Br)	CU NIPDAU	Level-1-260C-UNLIM	-40 to 85	HC4066	Samples
SN74HC4066DBR	ACTIVE	SSOP	DB	14	2000	Green (RoHS & no Sb/Br)	CU NIPDAU	Level-1-260C-UNLIM	-40 to 85	HC4066	Samples
SN74HC4066DR	ACTIVE	SOIC	D	14	2500	Green (RoHS & no Sb/Br)	CU NIPDAU	Level-1-260C-UNLIM	-40 to 85	HC4066	Samples
SN74HC4066DRE4	ACTIVE	SOIC	D	14	2500	Green (RoHS & no Sb/Br)	CU NIPDAU	Level-1-260C-UNLIM	-40 to 85	HC4066	Samples
SN74HC4066DRG4	ACTIVE	SOIC	D	14	2500	Green (RoHS & no Sb/Br)	CU NIPDAU	Level-1-260C-UNLIM	-40 to 85	HC4066	Samples
SN74HC4066DT	ACTIVE	SOIC	D	14	250	Green (RoHS & no Sb/Br)	CU NIPDAU	Level-1-260C-UNLIM	-40 to 85	HC4066	Samples
SN74HC4066N	ACTIVE	PDIP	N	14	25	Green (RoHS & no Sb/Br)	CU NIPDAU	N / A for Pkg Type	-40 to 85	SN74HC4066N	Samples
SN74HC4066NSR	ACTIVE	SO	NS	14	2000	Green (RoHS & no Sb/Br)	CU NIPDAU	Level-1-260C-UNLIM	-40 to 85	HC4066	Samples
SN74HC4066PW	ACTIVE	TSSOP	PW	14	90	Green (RoHS & no Sb/Br)	CU NIPDAU	Level-1-260C-UNLIM	-40 to 85	HC4066	Samples
SN74HC4066PWR	ACTIVE	TSSOP	PW	14	2000	Green (RoHS & no Sb/Br)	CU NIPDAU	Level-1-260C-UNLIM	-40 to 85	HC4066	Samples
SN74HC4066PWRG4	ACTIVE	TSSOP	PW	14	2000	Green (RoHS & no Sb/Br)	CU NIPDAU	Level-1-260C-UNLIM	-40 to 85	HC4066	Samples
SN74HC4066PWT	ACTIVE	TSSOP	PW	14	250	Green (RoHS & no Sb/Br)	CU NIPDAU	Level-1-260C-UNLIM	-40 to 85	HC4066	Samples

(1) The marketing status values are defined as follows:

ACTIVE: Product device recommended for new designs.

LIFEBUY: TI has announced that the device will be discontinued, and a lifetime-buy period is in effect.

NRND: Not recommended for new designs. Device is in production to support existing customers, but TI does not recommend using this part in a new design.

PREVIEW: Device has been announced but is not in production. Samples may or may not be available.

OBSOLETE: TI has discontinued the production of the device.

(2) **RoHS:** TI defines "RoHS" to mean semiconductor products that are compliant with the current EU RoHS requirements for all 10 RoHS substances, including the requirement that RoHS substance do not exceed 0.1% by weight in homogeneous materials. Where designed to be soldered at high temperatures, "RoHS" products are suitable for use in specified lead-free processes. TI may reference these types of products as "Pb-Free".

RoHS Exempt: TI defines "RoHS Exempt" to mean products that contain lead but are compliant with EU RoHS pursuant to a specific EU RoHS exemption.

Green: TI defines "Green" to mean the content of Chlorine (Cl) and Bromine (Br) based flame retardants meet JS709B low halogen requirements of ≤ 1000 ppm threshold. Antimony trioxide based flame retardants must also meet the ≤ 1000 ppm threshold requirement.

(3) MSL, Peak Temp. - The Moisture Sensitivity Level rating according to the JEDEC industry standard classifications, and peak solder temperature.

(4) There may be additional marking, which relates to the logo, the lot trace code information, or the environmental category on the device.

(5) Multiple Device Markings will be inside parentheses. Only one Device Marking contained in parentheses and separated by a "~" will appear on a device. If a line is indented then it is a continuation of the previous line and the two combined represent the entire Device Marking for that device.

(6) Lead/Ball Finish - Orderable Devices may have multiple material finish options. Finish options are separated by a vertical ruled line. Lead/Ball Finish values may wrap to two lines if the finish value exceeds the maximum column width.

Important Information and Disclaimer: The information provided on this page represents TI's knowledge and belief as of the date that it is provided. TI bases its knowledge and belief on information provided by third parties, and makes no representation or warranty as to the accuracy of such information. Efforts are underway to better integrate information from third parties. TI has taken and continues to take reasonable steps to provide representative and accurate information but may not have conducted destructive testing or chemical analysis on incoming materials and chemicals. TI and TI suppliers consider certain information to be proprietary, and thus CAS numbers and other limited information may not be available for release.

In no event shall TI's liability arising out of such information exceed the total purchase price of the TI part(s) at issue in this document sold by TI to Customer on an annual basis.

TAPE AND REEL INFORMATION

QUADRANT ASSIGNMENTS FOR PIN 1 ORIENTATION IN TAPE

*All dimensions are nominal

Device	Package Type	Package Drawing	Pins	SPQ	Reel Diameter (mm)	Reel Width W1 (mm)	A0 (mm)	B0 (mm)	K0 (mm)	P1 (mm)	W (mm)	Pin1 Quadrant
SN74HC4066DR	SOIC	D	14	2500	330.0	16.4	6.5	9.0	2.1	8.0	16.0	Q1
SN74HC4066DT	SOIC	D	14	250	330.0	16.4	6.5	9.0	2.1	8.0	16.0	Q1
SN74HC4066NSR	SO	NS	14	2000	330.0	16.4	8.2	10.5	2.5	12.0	16.0	Q1
SN74HC4066PWR	TSSOP	PW	14	2000	330.0	12.4	6.9	5.6	1.6	8.0	12.0	Q1
SN74HC4066PWT	TSSOP	PW	14	250	330.0	12.4	6.9	5.6	1.6	8.0	12.0	Q1

TAPE AND REEL BOX DIMENSIONS

*All dimensions are nominal

Device	Package Type	Package Drawing	Pins	SPQ	Length (mm)	Width (mm)	Height (mm)
SN74HC4066DR	SOIC	D	14	2500	367.0	367.0	38.0
SN74HC4066DT	SOIC	D	14	250	210.0	185.0	35.0
SN74HC4066NSR	SO	NS	14	2000	367.0	367.0	38.0
SN74HC4066PWR	TSSOP	PW	14	2000	367.0	367.0	35.0
SN74HC4066PWT	TSSOP	PW	14	250	367.0	367.0	35.0

MECHANICAL DATA

NS (R-PDSO-G**)

PLASTIC SMALL-OUTLINE PACKAGE

14-PINS SHOWN



- NOTES:
- A. All linear dimensions are in millimeters.
 - B. This drawing is subject to change without notice.
 - C. Body dimensions do not include mold flash or protrusion, not to exceed 0,15.

D (R-PDSO-G14)

PLASTIC SMALL OUTLINE



- NOTES:
- A. All linear dimensions are in inches (millimeters).
 - B. This drawing is subject to change without notice.
 -  Body length does not include mold flash, protrusions, or gate burrs. Mold flash, protrusions, or gate burrs shall not exceed 0.006 (0,15) each side.
 -  Body width does not include interlead flash. Interlead flash shall not exceed 0.017 (0,43) each side.
 - E. Reference JEDEC MS-012 variation AB.

D (R-PDSO-G14)

PLASTIC SMALL OUTLINE



4211283-3/E 08/12

- NOTES:
- All linear dimensions are in millimeters.
 - This drawing is subject to change without notice.
 - Publication IPC-7351 is recommended for alternate designs.
 - Laser cutting apertures with trapezoidal walls and also rounding corners will offer better paste release. Customers should contact their board assembly site for stencil design recommendations. Refer to IPC-7525 for other stencil recommendations.
 - Customers should contact their board fabrication site for solder mask tolerances between and around signal pads.

PW (R-PDSO-G14)

PLASTIC SMALL OUTLINE



4211284-2/G 08/15

- NOTES:
- All linear dimensions are in millimeters.
 - This drawing is subject to change without notice.
 - Publication IPC-7351 is recommended for alternate designs.
 - Laser cutting apertures with trapezoidal walls and also rounding corners will offer better paste release. Customers should contact their board assembly site for stencil design recommendations. Refer to IPC-7525 for other stencil recommendations.
 - Customers should contact their board fabrication site for solder mask tolerances between and around signal pads.

N (R-PDIP-T**)

PLASTIC DUAL-IN-LINE PACKAGE

16 PINS SHOWN

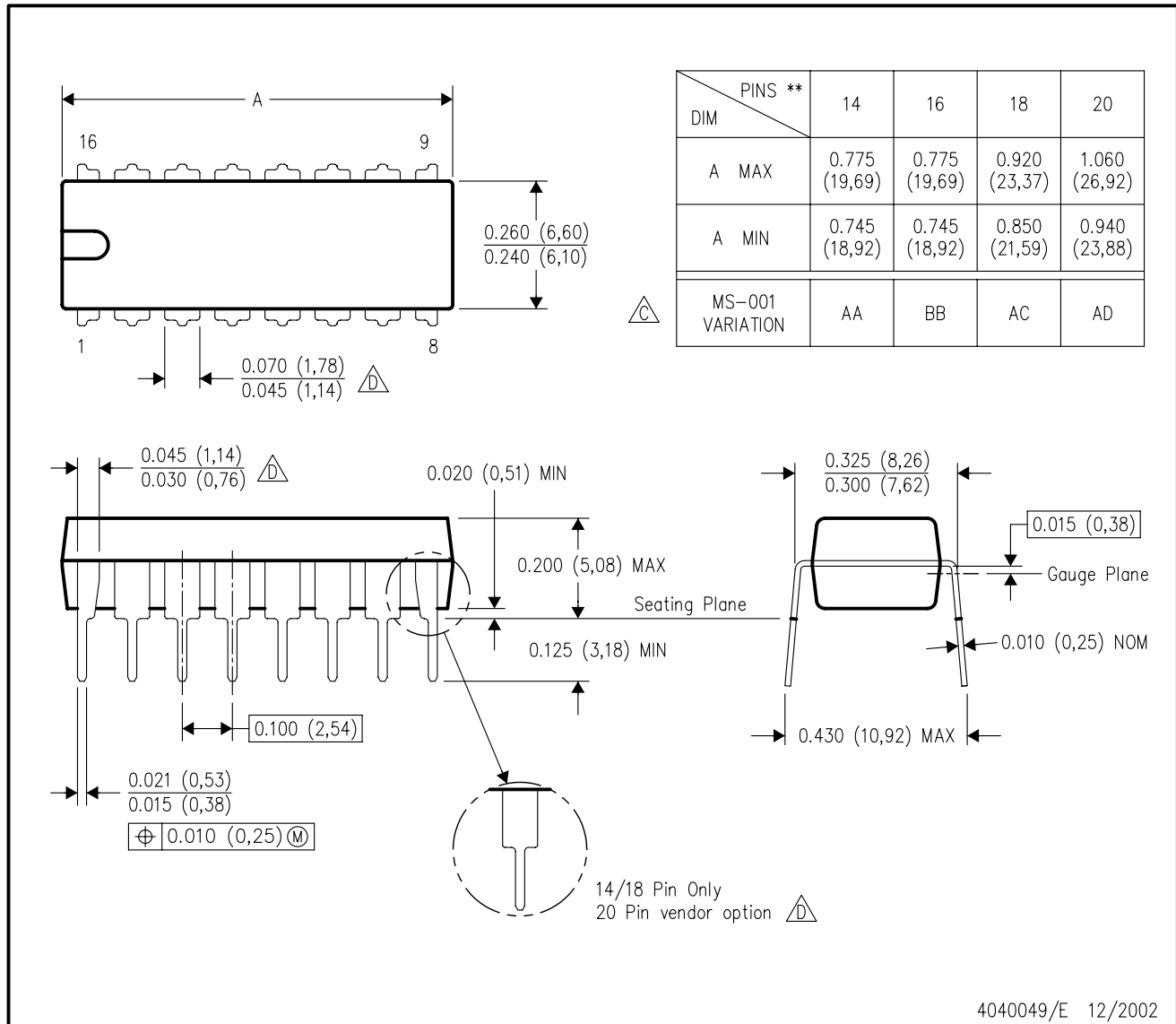

4040049/E 12/2002

- NOTES:
- A. All linear dimensions are in inches (millimeters).
 - B. This drawing is subject to change without notice.
 - $\triangle C$ Falls within JEDEC MS-001, except 18 and 20 pin minimum body length (Dim A).
 - $\triangle D$ The 20 pin end lead shoulder width is a vendor option, either half or full width.

DB (R-PDSO-G**)

PLASTIC SMALL-OUTLINE

28 PINS SHOWN



- NOTES: A. All linear dimensions are in millimeters.
 B. This drawing is subject to change without notice.
 C. Body dimensions do not include mold flash or protrusion not to exceed 0,15.
 D. Falls within JEDEC MO-150

IMPORTANT NOTICE AND DISCLAIMER

TI PROVIDES TECHNICAL AND RELIABILITY DATA (INCLUDING DATASHEETS), DESIGN RESOURCES (INCLUDING REFERENCE DESIGNS), APPLICATION OR OTHER DESIGN ADVICE, WEB TOOLS, SAFETY INFORMATION, AND OTHER RESOURCES "AS IS" AND WITH ALL FAULTS, AND DISCLAIMS ALL WARRANTIES, EXPRESS AND IMPLIED, INCLUDING WITHOUT LIMITATION ANY IMPLIED WARRANTIES OF MERCHANTABILITY, FITNESS FOR A PARTICULAR PURPOSE OR NON-INFRINGEMENT OF THIRD PARTY INTELLECTUAL PROPERTY RIGHTS.

These resources are intended for skilled developers designing with TI products. You are solely responsible for (1) selecting the appropriate TI products for your application, (2) designing, validating and testing your application, and (3) ensuring your application meets applicable standards, and any other safety, security, or other requirements. These resources are subject to change without notice. TI grants you permission to use these resources only for development of an application that uses the TI products described in the resource. Other reproduction and display of these resources is prohibited. No license is granted to any other TI intellectual property right or to any third party intellectual property right. TI disclaims responsibility for, and you will fully indemnify TI and its representatives against, any claims, damages, costs, losses, and liabilities arising out of your use of these resources.

TI's products are provided subject to TI's Terms of Sale (www.ti.com/legal/termsofsale.html) or other applicable terms available either on ti.com or provided in conjunction with such TI products. TI's provision of these resources does not expand or otherwise alter TI's applicable warranties or warranty disclaimers for TI products.

Mailing Address: Texas Instruments, Post Office Box 655303, Dallas, Texas 75265
Copyright © 2019, Texas Instruments Incorporated

Looking for pricing, stock, or lifecycle information?

Click below to explore more details on WIN SOURCE:

 [View SN74HC4066DRG4 on WIN SOURCE](#)

 [Texas Instruments](#) Information

Optimize Your Supply Chain with WIN SOURCE Solutions

-  Global Sourcing Solution
-  Obsolete Management
-  Cost Control Management
-  Shortage Management
-  Alternative Solution
-  Excess Inventory Management