



**THE DATASHEET OF
AN8007M**



AN80xx/AN80xxM Series

3-pin, positive output, low dropout voltage regulator (50 mA type)

Overview

The AN80xx series and the AN80xxM series are 3-pin, low dropout, fixed positive output type monolithic voltage regulators. Since their power consumption can be minimized, they are suitable for battery-used power supply and reference voltage. 13 types of output voltage are available; 2V, 2.5V, 3V, 3.5V (SSIP003-P-0000 only), 4V, 4.5V, 5V, 6V, 7V, 8V, 8.5V, 9V, and 10V.

Features

- Input/output voltage difference: 0.3V max.
- Output current of up to 50mA
- Low bias current: 0.6mA typ.
- Output voltage: 2V, 2.5V, 3V, 3.5V (SSIP003-P-0000 only), 4V, 4.5V, 5V, 6V, 7V, 8V, 8.5V, 9V, and 10V
- Built-in overcurrent protection circuit

Block Diagram (AN80xxM series)

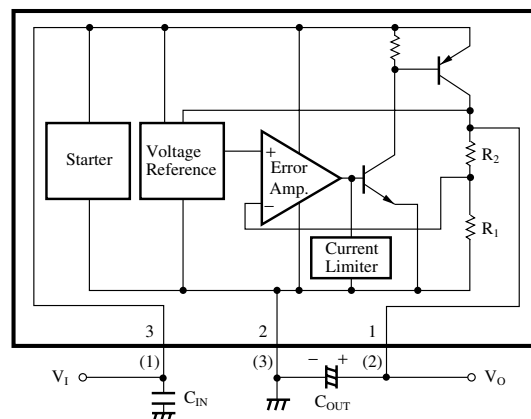

$$R_1 = 5k\Omega$$

$$C_{IN} = 0.33\mu F$$

$$C_{OUT} = 10\mu F$$

Note) The number in () shows the pin number for the AN80xx series.

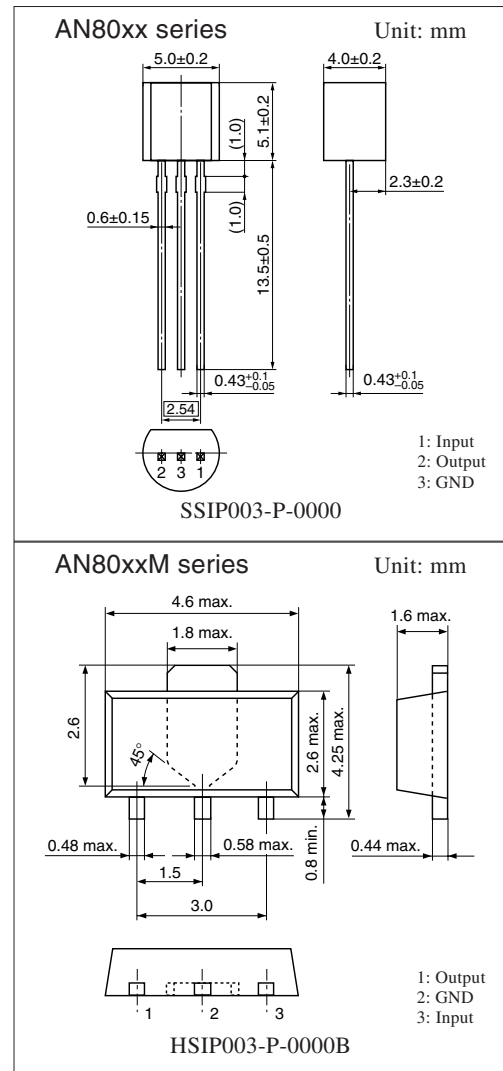

■ Absolute Maximum Ratings at $T_a = 25^\circ\text{C}$

Parameter		Symbol	Rating	Unit
Supply voltage		V_I	20	V
Supply current		I_{CC}	100	mA
Power dissipation		P_D	650 *	mW
Operating ambient temperature		T_{opr}	-30 to +80	$^\circ\text{C}$
Storage temperature	AN80xx series	T_{stg}	-55 to +150	$^\circ\text{C}$
	AN80xxM series		-55 to +125	

* AN80xxM series is mounted on standard board (glass epoxy: 20mm × 20mm × t1.7mm with Cu foil of 1cm² or more).

■ Electrical Characteristics at $T_a = 25^\circ\text{C}$

• AN8002, AN8002M (2V type)

Parameter	Symbol	Conditions	Min	Typ	Max	Unit
Output voltage	V_O	$T_j = 25^\circ\text{C}$	1.92	2	2.08	V
Line regulation	REG_{IN}	$V_I = 2.5$ to 8V, $T_j = 25^\circ\text{C}$	—	2	40	mV
Load regulation	REG_L	$I_O = 1$ to 40mA, $T_j = 25^\circ\text{C}$	—	7	20	mV
		$I_O = 1$ to 50mA, $T_j = 25^\circ\text{C}$	—	10	25	mV
Minimum input/output voltage difference	$V_{DIF(min)}$	$V_I = 1.9\text{V}$, $I_O = 20\text{mA}$, $T_j = 25^\circ\text{C}$	—	0.06	0.2	V
		$V_I = 1.9\text{V}$, $I_O = 50\text{mA}$, $T_j = 25^\circ\text{C}$	—	0.12	0.3	V
Bias current	I_{Bias}	$I_O = 0\text{mA}$, $T_j = 25^\circ\text{C}$	—	0.6	1	mA
Ripple rejection ratio	RR	$V_I = 3$ to 5V, $f = 120\text{Hz}$	62	74	—	dB
Output noise voltage	V_{no}	$f = 10\text{Hz}$ to 100kHz	—	60	—	μV
Output voltage temperature coefficient	$\Delta V_O/T_a$	$T_j = -30$ to $+125^\circ\text{C}$	—	0.1	—	$\text{mV}/^\circ\text{C}$

Note 1) The specified condition $T_j = 25^\circ\text{C}$ means that the test should be carried out within so short a test time (within 10ms) that the characteristic value drift due to the chip junction temperature rise can be ignored.

Note 2) Unless otherwise specified, $V_I = 3\text{V}$, $I_O = 20\text{mA}$ and $C_O = 10\mu\text{F}$.

• AN8025, AN8025M (2.5V type)

Parameter	Symbol	Conditions	Min	Typ	Max	Unit
Output voltage	V_O	$T_j = 25^\circ\text{C}$	2.4	2.5	2.6	V
Line regulation	REG_{IN}	$V_I = 3$ to 8.5V, $T_j = 25^\circ\text{C}$	—	2.5	50	mV
Load regulation	REG_L	$I_O = 1$ to 40mA, $T_j = 25^\circ\text{C}$	—	8	20	mV
		$I_O = 1$ to 50mA, $T_j = 25^\circ\text{C}$	—	12.5	25	mV
Minimum input/output voltage difference	$V_{DIF(min)}$	$V_I = 2.4\text{V}$, $I_O = 20\text{mA}$, $T_j = 25^\circ\text{C}$	—	0.07	0.2	V
		$V_I = 2.4\text{V}$, $I_O = 50\text{mA}$, $T_j = 25^\circ\text{C}$	—	0.12	0.3	V
Bias current	I_{Bias}	$I_O = 0\text{mA}$, $T_j = 25^\circ\text{C}$	—	0.6	1	mA
Ripple rejection ratio	RR	$V_I = 3.5$ to 5.5V, $f = 120\text{Hz}$	60	72	—	dB
Output noise voltage	V_{no}	$f = 10\text{Hz}$ to 100kHz	—	65	—	μV
Output voltage temperature coefficient	$\Delta V_O/T_a$	$T_j = -30$ to $+125^\circ\text{C}$	—	0.13	—	$\text{mV}/^\circ\text{C}$

Note 1) The specified condition $T_j = 25^\circ\text{C}$ means that the test should be carried out within so short a test time (within 10ms) that the characteristic value drift due to the chip junction temperature rise can be ignored.

Note 2) Unless otherwise specified, $V_I = 3.5\text{V}$, $I_O = 20\text{mA}$ and $C_O = 10\mu\text{F}$.

■ Electrical Characteristics at $T_a = 25^\circ\text{C}$ (continued)

• AN8003, AN8003M (3V type)

Parameter	Symbol	Conditions	Min	Typ	Max	Unit
Output voltage	V_O	$T_j = 25^\circ\text{C}$	2.88	3	3.12	V
Line regulation	REG_{IN}	$V_i = 3.5$ to 9V , $T_j = 25^\circ\text{C}$	—	3	50	mV
Load regulation	REG_{L}	$I_o = 1$ to 40mA , $T_j = 25^\circ\text{C}$	—	9	25	mV
		$I_o = 1$ to 50mA , $T_j = 25^\circ\text{C}$	—	15	30	mV
Minimum input/output voltage difference	$V_{\text{DIF}(\text{min})}$	$V_i = 2.9\text{V}$, $I_o = 20\text{mA}$, $T_j = 25^\circ\text{C}$	—	0.07	0.2	V
		$V_i = 2.9\text{V}$, $I_o = 50\text{mA}$, $T_j = 25^\circ\text{C}$	—	0.12	0.3	V
Bias current	I_{Bias}	$I_o = 0\text{mA}$, $T_j = 25^\circ\text{C}$	—	0.6	1	mA
Ripple rejection ratio	RR	$V_i = 4$ to 6V , $f = 120\text{Hz}$	58	70	—	dB
Output noise voltage	V_{no}	$f = 10\text{Hz}$ to 100kHz	—	70	—	μV
Output voltage temperature coefficient	$\Delta V_O/T_a$	$T_j = -30$ to $+125^\circ\text{C}$	—	0.15	—	$\text{mV}/^\circ\text{C}$

Note 1) The specified condition $T_j = 25^\circ\text{C}$ means that the test should be carried out within so short a test time (within 10ms) that the characteristic value drift due to the chip junction temperature rise can be ignored.

Note 2) Unless otherwise specified, $V_i = 4\text{V}$, $I_o = 20\text{mA}$ and $C_o = 10\mu\text{F}$.

• AN8035(3.5V type)

Parameter	Symbol	Conditions	Min	Typ	Max	Unit
Output voltage	V_O	$T_j = 25^\circ\text{C}$	3.36	3.5	3.64	V
Line regulation	REG_{IN}	$V_i = 4$ to 9.5V , $T_j = 25^\circ\text{C}$	—	3.5	50	mV
Load regulation	REG_{L}	$I_o = 1$ to 40mA , $T_j = 25^\circ\text{C}$	—	10	30	mV
		$I_o = 1$ to 50mA , $T_j = 25^\circ\text{C}$	—	20	40	mV
Minimum input/output voltage difference	$V_{\text{DIF}(\text{min})}$	$V_i = 3.4\text{V}$, $I_o = 20\text{mA}$, $T_j = 25^\circ\text{C}$	—	0.07	0.2	V
		$V_i = 3.4\text{V}$, $I_o = 50\text{mA}$, $T_j = 25^\circ\text{C}$	—	0.12	0.3	V
Bias current	I_{Bias}	$I_o = 0\text{mA}$, $T_j = 25^\circ\text{C}$	—	0.6	1	mA
Ripple rejection ratio	RR	$V_i = 4.5$ to 6.5V , $f = 120\text{Hz}$	57	69	—	dB
Output noise voltage	V_{no}	$f = 10\text{Hz}$ to 100kHz	—	75	—	μV
Output voltage temperature coefficient	$\Delta V_O/T_a$	$T_j = -30$ to $+125^\circ\text{C}$	—	0.2	—	$\text{mV}/^\circ\text{C}$

Note 1) The specified condition $T_j = 25^\circ\text{C}$ means that the test should be carried out within so short a test time (within 10ms) that the characteristic value drift due to the chip junction temperature rise can be ignored.

Note 2) Unless otherwise specified, $V_i = 4.5\text{V}$, $I_o = 20\text{mA}$ and $C_o = 10\mu\text{F}$.

• AN8004, AN8004M (4V type)

Parameter	Symbol	Conditions	Min	Typ	Max	Unit
Output voltage	V_O	$T_j = 25^\circ\text{C}$	3.84	4	4.16	V
Line regulation	REG_{IN}	$V_i = 4.5$ to 10V , $T_j = 25^\circ\text{C}$	—	3.5	50	mV
Load regulation	REG_{L}	$I_o = 1$ to 40mA , $T_j = 25^\circ\text{C}$	—	10	30	mV
		$I_o = 1$ to 50mA , $T_j = 25^\circ\text{C}$	—	20	40	mV
Minimum input/output voltage difference	$V_{\text{DIF}(\text{min})}$	$V_i = 3.8\text{V}$, $I_o = 20\text{mA}$, $T_j = 25^\circ\text{C}$	—	0.07	0.2	V
		$V_i = 3.8\text{V}$, $I_o = 50\text{mA}$, $T_j = 25^\circ\text{C}$	—	0.12	0.3	V
Bias current	I_{Bias}	$I_o = 0\text{mA}$, $T_j = 25^\circ\text{C}$	—	0.6	1	mA
Ripple rejection ratio	RR	$V_i = 5$ to 7V , $f = 120\text{Hz}$	56	67	—	dB
Output noise voltage	V_{no}	$f = 10\text{Hz}$ to 100kHz	—	80	—	μV
Output voltage temperature coefficient	$\Delta V_O/T_a$	$T_j = -30$ to $+125^\circ\text{C}$	—	0.2	—	$\text{mV}/^\circ\text{C}$

Note 1) The specified condition $T_j = 25^\circ\text{C}$ means that the test should be carried out within so short a test time (within 10ms) that the characteristic value drift due to the chip junction temperature rise can be ignored.

Note 2) Unless otherwise specified, $V_i = 5\text{V}$, $I_o = 20\text{mA}$ and $C_o = 10\mu\text{F}$.

■ Electrical Characteristics at $T_a = 25^\circ\text{C}$ (continued)

• AN8045, AN8045M (4.5V type)

Parameter	Symbol	Conditions	Min	Typ	Max	Unit
Output voltage	V_O	$T_j = 25^\circ\text{C}$	4.32	4.5	4.68	V
Line regulation	REG_{IN}	$V_i = 5$ to 10.5V , $T_j = 25^\circ\text{C}$	—	4	50	mV
Load regulation	REG_{L}	$I_o = 1$ to 40mA , $T_j = 25^\circ\text{C}$	—	11	35	mV
		$I_o = 1$ to 50mA , $T_j = 25^\circ\text{C}$	—	23	45	mV
Minimum input/output voltage difference	$V_{\text{DIF}(\text{min})}$	$V_i = 4.3\text{V}$, $I_o = 20\text{mA}$, $T_j = 25^\circ\text{C}$	—	0.07	0.2	V
		$V_i = 4.3\text{V}$, $I_o = 50\text{mA}$, $T_j = 25^\circ\text{C}$	—	0.12	0.3	V
Bias current	I_{Bias}	$I_o = 0\text{mA}$, $T_j = 25^\circ\text{C}$	—	0.7	1	mA
Ripple rejection ratio	RR	$V_i = 5.5$ to 7.5V , $f = 120\text{Hz}$	54	66	—	dB
Output noise voltage	V_{no}	$f = 10\text{Hz}$ to 100kHz	—	85	—	μV
Output voltage temperature coefficient	$\Delta V_O/T_a$	$T_j = -30$ to $+125^\circ\text{C}$	—	0.23	—	$\text{mV}/^\circ\text{C}$

Note 1) The specified condition $T_j = 25^\circ\text{C}$ means that the test should be carried out within so short a test time (within 10ms) that the characteristic value drift due to the chip junction temperature rise can be ignored.

Note 2) Unless otherwise specified, $V_i = 5.5\text{V}$, $I_o = 20\text{mA}$ and $C_o = 10\mu\text{F}$.

• AN8005, AN8005M (5V type)

Parameter	Symbol	Conditions	Min	Typ	Max	Unit
Output voltage	V_O	$T_j = 25^\circ\text{C}$	4.8	5	5.2	V
Line regulation	REG_{IN}	$V_i = 5.5$ to 11V , $T_j = 25^\circ\text{C}$	—	4.5	50	mV
Load regulation	REG_{L}	$I_o = 1$ to 40mA , $T_j = 25^\circ\text{C}$	—	12	40	mV
		$I_o = 1$ to 50mA , $T_j = 25^\circ\text{C}$	—	25	50	mV
Minimum input/output voltage difference	$V_{\text{DIF}(\text{min})}$	$V_i = 4.8\text{V}$, $I_o = 20\text{mA}$, $T_j = 25^\circ\text{C}$	—	0.07	0.2	V
		$V_i = 4.8\text{V}$, $I_o = 50\text{mA}$, $T_j = 25^\circ\text{C}$	—	0.12	0.3	V
Bias current	I_{Bias}	$I_o = 0\text{mA}$, $T_j = 25^\circ\text{C}$	—	0.7	1	mA
Ripple rejection ratio	RR	$V_i = 6$ to 8V , $f = 120\text{Hz}$	52	64	—	dB
Output noise voltage	V_{no}	$f = 10\text{Hz}$ to 100kHz	—	95	—	μV
Output voltage temperature coefficient	$\Delta V_O/T_a$	$T_j = -30$ to $+125^\circ\text{C}$	—	0.25	—	$\text{mV}/^\circ\text{C}$

Note 1) The specified condition $T_j = 25^\circ\text{C}$ means that the test should be carried out within so short a test time (within 10ms) that the characteristic value drift due to the chip junction temperature rise can be ignored.

Note 2) Unless otherwise specified, $V_i = 6\text{V}$, $I_o = 20\text{mA}$ and $C_o = 10\mu\text{F}$.

• AN8006, AN8006M (6V type)

Parameter	Symbol	Conditions	Min	Typ	Max	Unit
Output voltage	V_O	$T_j = 25^\circ\text{C}$	5.76	6	6.24	V
Line regulation	REG_{IN}	$V_i = 6.5$ to 12V , $T_j = 25^\circ\text{C}$	—	5.5	60	mV
Load regulation	REG_{L}	$I_o = 1$ to 40mA , $T_j = 25^\circ\text{C}$	—	13	45	mV
		$I_o = 1$ to 50mA , $T_j = 25^\circ\text{C}$	—	28	55	mV
Minimum input/output voltage difference	$V_{\text{DIF}(\text{min})}$	$V_i = 5.8\text{V}$, $I_o = 20\text{mA}$, $T_j = 25^\circ\text{C}$	—	0.07	0.2	V
		$V_i = 5.8\text{V}$, $I_o = 50\text{mA}$, $T_j = 25^\circ\text{C}$	—	0.13	0.3	V
Bias current	I_{Bias}	$I_o = 0\text{mA}$, $T_j = 25^\circ\text{C}$	—	0.7	1.2	mA
Ripple rejection ratio	RR	$V_i = 7$ to 9V , $f = 120\text{Hz}$	51	63	—	dB
Output noise voltage	V_{no}	$f = 10\text{Hz}$ to 100kHz	—	105	—	μV
Output voltage temperature coefficient	$\Delta V_O/T_a$	$T_j = -30$ to $+125^\circ\text{C}$	—	0.3	—	$\text{mV}/^\circ\text{C}$

Note 1) The specified condition $T_j = 25^\circ\text{C}$ means that the test should be carried out within so short a test time (within 10ms) that the characteristic value drift due to the chip junction temperature rise can be ignored.

Note 2) Unless otherwise specified, $V_i = 7\text{V}$, $I_o = 20\text{mA}$ and $C_o = 10\mu\text{F}$.

■ Electrical Characteristics at $T_a = 25^\circ\text{C}$ (continued)

• AN8007, AN8007M (7V type)

Parameter	Symbol	Conditions	Min	Typ	Max	Unit
Output voltage	V_O	$T_j = 25^\circ\text{C}$	6.72	7	7.28	V
Line regulation	REG_{IN}	$V_i = 7.5$ to 13V , $T_j = 25^\circ\text{C}$	—	6.5	70	mV
Load regulation	REG_L	$I_O = 1$ to 40mA , $T_j = 25^\circ\text{C}$	—	14	50	mV
		$I_O = 1$ to 50mA , $T_j = 25^\circ\text{C}$	—	31	60	mV
Minimum input/output voltage difference	$V_{DIF(min)}$	$V_i = 6.8\text{V}$, $I_O = 20\text{mA}$, $T_j = 25^\circ\text{C}$	—	0.07	0.2	V
		$V_i = 6.8\text{V}$, $I_O = 50\text{mA}$, $T_j = 25^\circ\text{C}$	—	0.13	0.3	V
Bias current	I_{Bias}	$I_O = 0\text{mA}$, $T_j = 25^\circ\text{C}$	—	0.7	1.3	mA
Ripple rejection ratio	RR	$V_i = 8$ to 10V , $f = 120\text{Hz}$	50	62	—	dB
Output noise voltage	V_{no}	$f = 10\text{Hz}$ to 100kHz	—	120	—	μV
Output voltage temperature coefficient	$\Delta V_O/T_a$	$T_j = -30$ to $+125^\circ\text{C}$	—	0.35	—	$\text{mV}/^\circ\text{C}$

Note 1) The specified condition $T_j = 25^\circ\text{C}$ means that the test should be carried out within so short a test time (within 10ms) that the characteristic value drift due to the chip junction temperature rise can be ignored.

Note 2) Unless otherwise specified, $V_i = 8\text{V}$, $I_O = 20\text{mA}$ and $C_O = 10\mu\text{F}$.

• AN8008, AN8008M (8V type)

Parameter	Symbol	Conditions	Min	Typ	Max	Unit
Output voltage	V_O	$T_j = 25^\circ\text{C}$	7.68	8	8.32	V
Line regulation	REG_{IN}	$V_i = 8.5$ to 14V , $T_j = 25^\circ\text{C}$	—	7.5	80	mV
Load regulation	REG_L	$I_O = 1$ to 40mA , $T_j = 25^\circ\text{C}$	—	15	55	mV
		$I_O = 1$ to 50mA , $T_j = 25^\circ\text{C}$	—	34	65	mV
Minimum input/output voltage difference	$V_{DIF(min)}$	$V_i = 7.8\text{V}$, $I_O = 20\text{mA}$, $T_j = 25^\circ\text{C}$	—	0.07	0.2	V
		$V_i = 7.8\text{V}$, $I_O = 50\text{mA}$, $T_j = 25^\circ\text{C}$	—	0.14	0.3	V
Bias current	I_{Bias}	$I_O = 0\text{mA}$, $T_j = 25^\circ\text{C}$	—	0.7	1.3	mA
Ripple rejection ratio	RR	$V_i = 9$ to 11V , $f = 120\text{Hz}$	49	61	—	dB
Output noise voltage	V_{no}	$f = 10\text{Hz}$ to 100kHz	—	135	—	μV
Output voltage temperature coefficient	$\Delta V_O/T_a$	$T_j = -30$ to $+125^\circ\text{C}$	—	0.4	—	$\text{mV}/^\circ\text{C}$

Note 1) The specified condition $T_j = 25^\circ\text{C}$ means that the test should be carried out within so short a test time (within 10ms) that the characteristic value drift due to the chip junction temperature rise can be ignored.

Note 2) Unless otherwise specified, $V_i = 9\text{V}$, $I_O = 20\text{mA}$ and $C_O = 10\mu\text{F}$.

• AN8085, AN8085M (8.5V type)

Parameter	Symbol	Conditions	Min	Typ	Max	Unit
Output voltage	V_O	$T_j = 25^\circ\text{C}$	8.16	8.50	8.84	V
Line regulation	REG_{IN}	$V_i = 9$ to 14.5V , $T_j = 25^\circ\text{C}$	—	8.3	90	mV
Load regulation	REG_L	$I_O = 1$ to 40mA , $T_j = 25^\circ\text{C}$	—	16	60	mV
		$I_O = 1$ to 50mA , $T_j = 25^\circ\text{C}$	—	36	70	mV
Minimum input/output voltage difference	$V_{DIF(min)}$	$V_i = 8.3\text{V}$, $I_O = 20\text{mA}$, $T_j = 25^\circ\text{C}$	—	0.07	0.2	V
		$V_i = 8.3\text{V}$, $I_O = 50\text{mA}$, $T_j = 25^\circ\text{C}$	—	0.14	0.3	V
Bias current	I_{Bias}	$I_O = 0\text{mA}$, $T_j = 25^\circ\text{C}$	—	0.8	1.4	mA
Ripple rejection ratio	RR	$V_i = 9.5$ to 11.5V , $f = 120\text{Hz}$	48	60	—	dB
Output noise voltage	V_{no}	$f = 10\text{Hz}$ to 100kHz	—	140	—	μV
Output voltage temperature coefficient	$\Delta V_O/T_a$	$T_j = -30$ to $+125^\circ\text{C}$	—	0.43	—	$\text{mV}/^\circ\text{C}$

Note 1) The specified condition $T_j = 25^\circ\text{C}$ means that the test should be carried out within so short a test time (within 10ms) that the characteristic value drift due to the chip junction temperature rise can be ignored.

Note 2) Unless otherwise specified, $V_i = 9.5\text{V}$, $I_O = 20\text{mA}$ and $C_O = 10\mu\text{F}$.

■ Electrical Characteristics at $T_a = 25^\circ\text{C}$ (continued)

• AN8009, AN8009M (9V type)

Parameter	Symbol	Conditions	Min	Typ	Max	Unit
Output voltage	V_O	$T_j = 25^\circ\text{C}$	8.64	9	9.36	V
Line regulation	REG_{IN}	$V_i = 9.5$ to 15V , $T_j = 25^\circ\text{C}$	—	9	100	mV
Load regulation	REG_{L}	$I_o = 1$ to 40mA , $T_j = 25^\circ\text{C}$	—	17	70	mV
		$I_o = 1$ to 50mA , $T_j = 25^\circ\text{C}$	—	37	75	mV
Minimum input/output voltage difference	$V_{\text{DIF}(\text{min})}$	$V_i = 8.8\text{V}$, $I_o = 20\text{mA}$, $T_j = 25^\circ\text{C}$	—	0.07	0.2	V
		$V_i = 8.8\text{V}$, $I_o = 50\text{mA}$, $T_j = 25^\circ\text{C}$	—	0.14	0.3	V
Bias current	I_{Bias}	$I_o = 0\text{mA}$, $T_j = 25^\circ\text{C}$	—	0.8	1.4	mA
Ripple rejection ratio	RR	$V_i = 10$ to 12V , $f = 120\text{Hz}$	47	59	—	dB
Output noise voltage	V_{no}	$f = 10\text{Hz}$ to 100kHz	—	150	—	μV
Output voltage temperature coefficient	$\Delta V_O/T_a$	$T_j = -30$ to $+125^\circ\text{C}$	—	0.45	—	$\text{mV}/^\circ\text{C}$

Note 1) The specified condition $T_j = 25^\circ\text{C}$ means that the test should be carried out within so short a test time (within 10ms) that the characteristic value drift due to the chip junction temperature rise can be ignored.

Note 2) Unless otherwise specified, $V_i = 10\text{V}$, $I_o = 20\text{mA}$ and $C_o = 10\mu\text{F}$.

• AN8010, AN8010M (10V type)

Parameter	Symbol	Conditions	Min	Typ	Max	Unit
Output voltage	V_O	$T_j = 25^\circ\text{C}$	9.6	10	10.4	V
Line regulation	REG_{IN}	$V_i = 10.5$ to 16V , $T_j = 25^\circ\text{C}$	—	10	100	mV
Load regulation	REG_{L}	$I_o = 1$ to 40mA , $T_j = 25^\circ\text{C}$	—	18	75	mV
		$I_o = 1$ to 50mA , $T_j = 25^\circ\text{C}$	—	40	85	mV
Minimum input/output voltage difference	$V_{\text{DIF}(\text{min})}$	$V_i = 9.8\text{V}$, $I_o = 20\text{mA}$, $T_j = 25^\circ\text{C}$	—	0.07	0.2	V
		$V_i = 9.8\text{V}$, $I_o = 50\text{mA}$, $T_j = 25^\circ\text{C}$	—	0.14	0.3	V
Bias current	I_{Bias}	$I_o = 0\text{mA}$, $T_j = 25^\circ\text{C}$	—	0.8	1.4	mA
Ripple rejection ratio	RR	$V_i = 11$ to 13V , $f = 120\text{Hz}$	46	58	—	dB
Output noise voltage	V_{no}	$f = 10\text{Hz}$ to 100kHz	—	165	—	μV
Output voltage temperature coefficient	$\Delta V_O/T_a$	$T_j = -30$ to $+125^\circ\text{C}$	—	0.5	—	$\text{mV}/^\circ\text{C}$

Note 1) The specified condition $T_j = 25^\circ\text{C}$ means that the test should be carried out within so short a test time (within 10ms) that the characteristic value drift due to the chip junction temperature rise can be ignored.

Note 2) Unless otherwise specified, $V_i = 11\text{V}$, $I_o = 20\text{mA}$ and $C_o = 10\mu\text{F}$.

■ Main Characteristics

$P_D - T_a$ (AN80xx series)

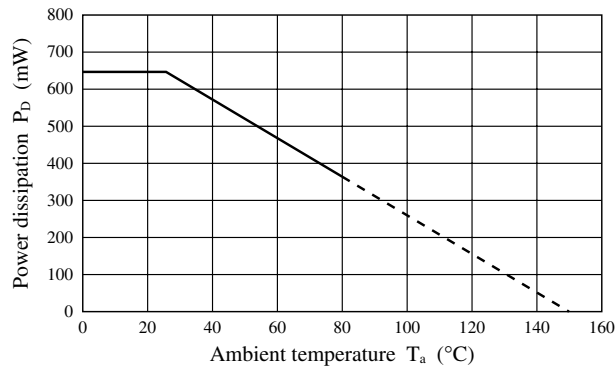

$P_D - T_a$ (AN80xxM series)

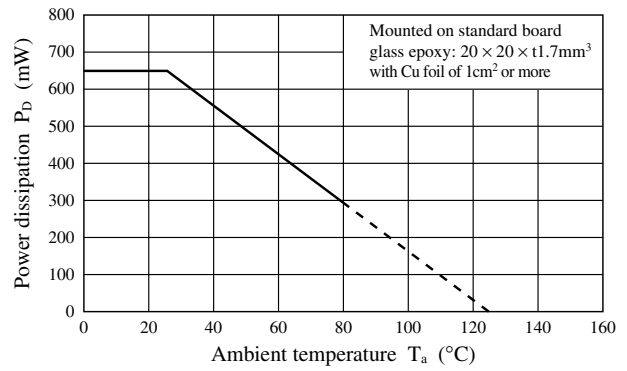

RR — f

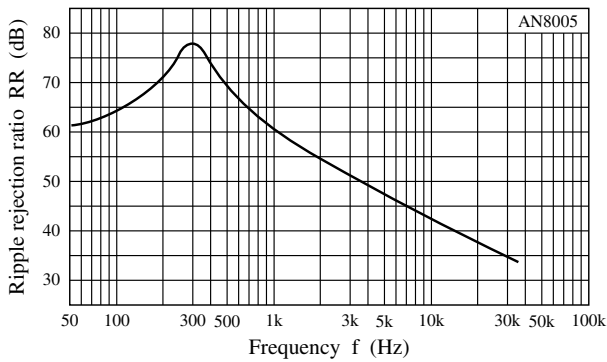

$V_O - V_I$

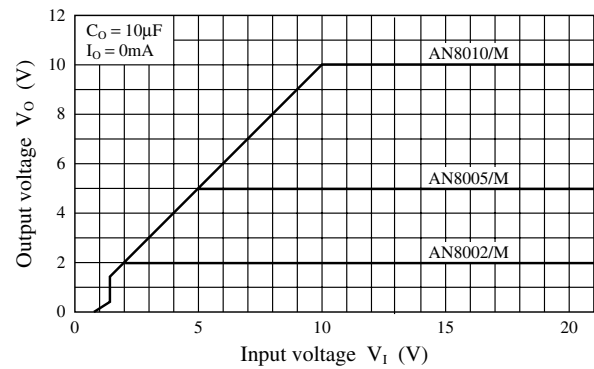

$V_O - I_O$

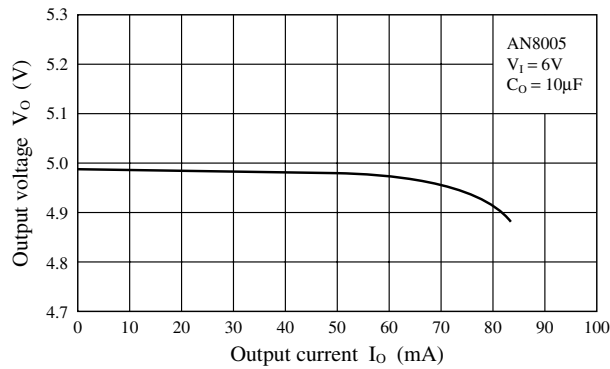

$V_O - T_a$

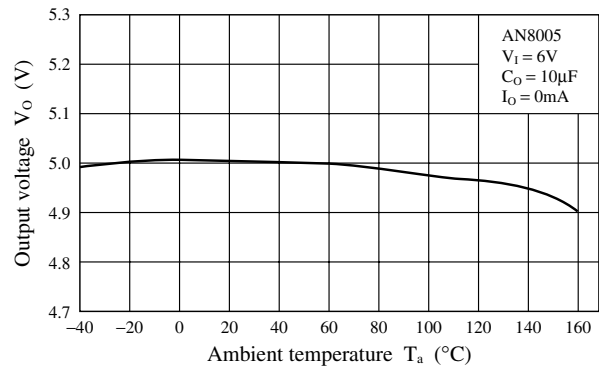

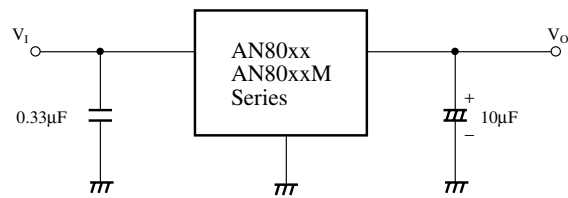

■ Application Circuit Example



- AN80xx and AN80xxM series have their internal gain increased in order to improve performance. When the power line on the output side is long, use a capacitor of $10\mu\text{F}$. Also, the capacitor on the output side should be attached as close to the IC as possible.
- When using at a low temperature, it is recommended to use the capacitors with low internal impedance (for example, tantalum capacitor) for output capacitors.

Looking for pricing, stock, or lifecycle information?

Click below to explore more details on WIN SOURCE:

-  [View AN8007M on WIN SOURCE](#)
-  [Panasonic Information](#)

Optimize Your Supply Chain with WIN SOURCE Solutions

-  Global Sourcing Solution
-  Obsolete Management
-  Cost Control Management
-  Shortage Management
-  Alternative Solution
-  Excess Inventory Management