



**THE DATASHEET OF
AN8013SH-E1**



Code No.: IC3F4736

Total Pages

Page

17

1

Product Standards

Part No.	AN8013SH
Package Code No.	SSOP010-P-0225A

Analogue LSI Business Unit
Semiconductor Company
Matsushita Electric Industrial Co., Ltd.

Established by	Applied by	Checked by	Prepared by
K.Komichi	M.Hiramatsu	J.Hara	J.Morita
K.Komichi	M.Hiramatsu	J.Hara	J.Morita

2006-08-24

Established

Revised

210801300106070

Semiconductor Company, Matsushita Electric Industrial Co., Ltd.

	Product Standards	AN8013SH	
		Total Pages	Page
		17	2

Contents

■ Overview	3
■ Features	3
■ Applications	3
■ Package	3
■ Type	3
■ Application Circuit Example	4
■ Block Diagram	5
■ Pin Descriptions	6
■ Absolute Maximum Ratings	7
■ Operating Supply Voltage Range	7
■ Recommended Operating Conditions	7
■ Electrical Characteristics	8
■ Electrical Characteristics (Reference values for design)	9
■ Test Circuit Diagram	10
■ Electrical Characteristics Test Procedures	14
■ Technical Data	17

2006-08-24		
Established	Revised	

	Product Standards	AN8013SH	
		Total Pages	Page
		17	3

AN8013SH

Single-channel step-up or step-down DC-DC converter control IC

■ Overview

AN8013SH is a single-channel DC-DC converter control IC using the PWM method.

This IC implements DC-DC converter that provide a single arbitrary output voltage that is either a stepped-up or stepped-down level. It features a wide operating supply voltage range, low power, and a built-in overcurrent protection circuit to protect the switching transistor from damage or destruction. The AN8013SH is provided in a 0.5 mm pitch 10-pin surface mounting package and is optimal for use in miniature high-efficiency portable power supplies.

■ Features

- Wide operating supply voltage range (3.6 V to 34 V)
- Small consumption current (2.4 mA typical)
- Supports control over a wide output frequency range: 20kHz to 500 kHz.
- Built-in pulse-by pulse overcurrent protection circuit (Detection voltage: $V_{CC} - 100$ mV)
- Built-in timer latch short-circuit protection circuit (charge current : 1.3 μ A typical)
- Incorporating an under-voltage lock-out circuit (U.V.L.O)
- Built-in reference voltage circuit (Error amplifier reference input: 0.75 V (allowance: $\pm 4\%$))
- Output block is open-collector (darlington) type.
- High absolute maximum rating of output current (100 mA)
- Duty ratio with small sample-to-sample variations ($55\% \pm 5\%$)

■ Applications

- Switching mode power supply units (in portable equipment and other applications)

■ Package

- 10 pin Plastic Shrink Small Outline Package (SSOP Type)

■ Type

- Silicon Monolithic Bipolar IC

2006-08-24		
Established	Revised	

■ Application Circuit Example

1. Step-down

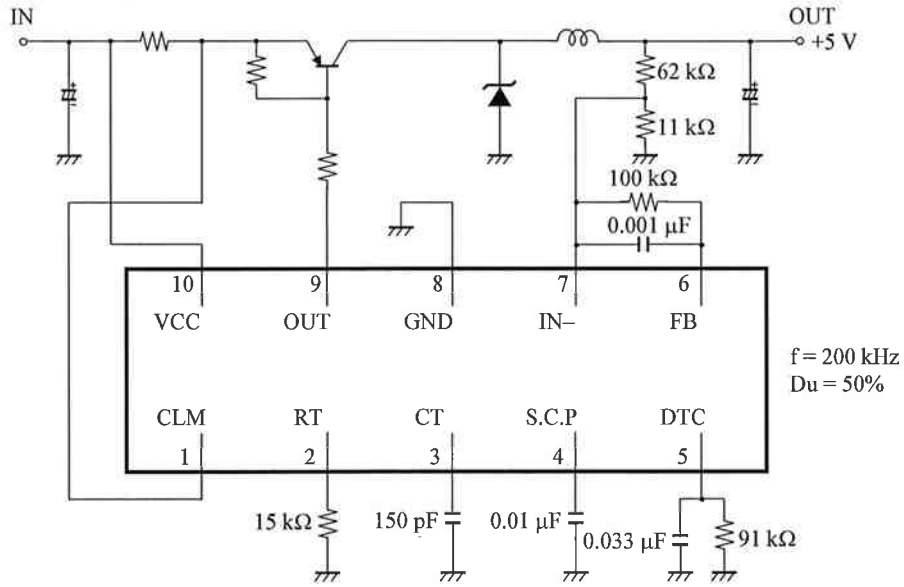

2. Step-up

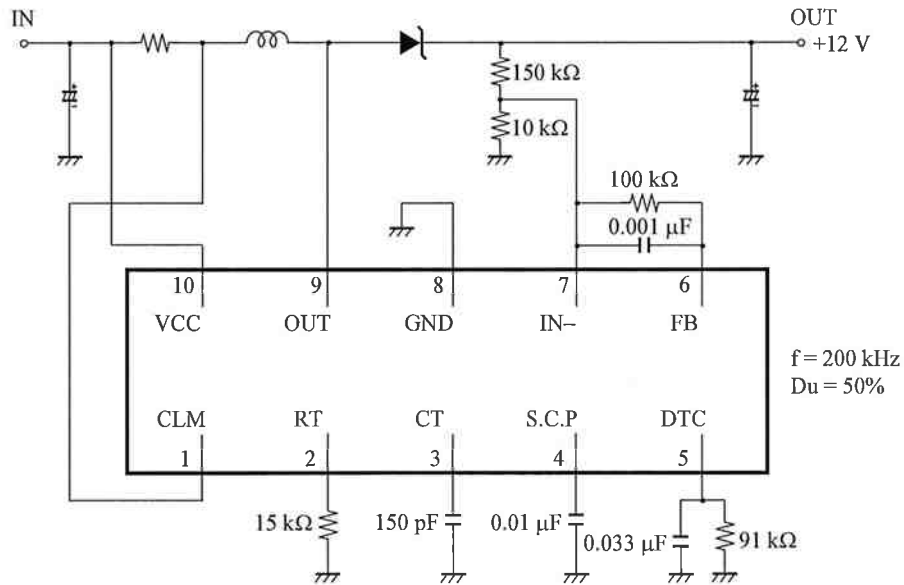

2006-08-24		
Established	Revised	

	Product Standards	AN8013SH	
		Total Pages	Page
		17	6

■ Pin Descriptions

Pin No.	Pin name	Type	Description
1	CLM	Input	Overcurrent protection input
2	RT	—	Oscillator frequency setup resistor connection
3	CT	—	Oscillator frequency setup capacitor connection
4	S.C.P	—	Capacitor connection for delay short-circuit protection
5	DTC	Input	Dead time control pin
6	FB	Output	Output of error amplifier
7	IN-	Input	Inverted input for error amplifier
8	GND	Ground	Ground pin
9	OUT	Output	Open collector output
10	VCC	Power supply	Supply voltage application

2006-08-24		
Established	Revised	

<h1>Product Standards</h1>		AN8013SH	
		Total Pages	Page
		17	7

■ Absolute Maximum Ratings

A No.	Parameter	Symbol	Rating	Unit	Notes
1	Supply voltage	V_{CC}	35	V	*1
2	Supply current	I_{CC}	—	mA	—
3	Power dissipation	P_D	115	mW	*2
4	Operating ambient temperature	T_{opr}	-30 to +85	°C	*3
5	Storage temperature	T_{stg}	-55 to +125	°C	*3
6	CLM pin allowable applied voltage	V_{CLM}	35	V	—
7	Error amplifier allowable input voltage	V_I	-0.3 to 2.5	V	—
8	DTC pin allowable applied voltage	V_{DTC}	2.5	V	—
9	OUT pin allowable applied voltage	V_{OUT}	35	V	—
10	Output current	I_O	100	mA	—

Notes) *1 : The values under the condition not exceeding the above absolute maximum ratings and the power dissipation.

*2 : The power dissipation shown is the value at $T_a = 85^\circ\text{C}$ for the independent (unmounted) IC package.

When using this IC, refer to the P_D - T_a diagram of the package standard page 4 and use under the condition not exceeding the allowable value.

*3 : Except for the power dissipation, operating ambient temperature, and storage temperature, all ratings are for $T_a = 25^\circ\text{C}$.

■ Operating supply voltage range

Parameter	Symbol	Range	Unit	Notes
Supply voltage range	V_{CC}	3.6 to 34	V	*

Note) *: The values under the condition not exceeding the above absolute maximum ratings and the power dissipation.

■ Recommended Operating Conditions

Parameter	Symbol	Min	Max	Unit	Notes
Supply voltage (0 to 3.6 V) rise time	$t_{r(VCC)}$	10	—	μs	*
Collector output voltage	V_{OUT}	—	34	V	*
Collector output current	I_{OUT}	—	50	mA	*
Timing capacitance	C_T	100	1 800	pF	*
Timing resistance	R_T	5.1	15	$\text{k}\Omega$	*
Output frequency	f_{OUT}	20	500	kHz	*
Time constant setting capacitance for short-circuit protection	C_{SCP}	1 000	—	pF	*

Note) *: Do not apply current or voltage from external source to any pin not listed above.

In the circuit current, (+) means the current flowing into IC and (-) means the current flowing out of IC.

2006-08-24		
Established	Revised	

		<h1>Product Standards</h1>		AN8013SH	
				Total Pages	Page
				17	8

■ Electrical Characteristics at $V_{CC} = 12\text{ V}$, $C_T = 150\text{ pF}$, $R_T = 15\text{ k}\Omega$

Note) $T_a = 25^\circ\text{C} \pm 2^\circ\text{C}$ unless otherwise specified.

B No.	Parameter	Symbol	Test circuits	Conditions	Limits			Unit	Notes
					Min	Typ	Max		
U.V.L.O. Block									
1	U.V.L.O. start voltage	V_{UON}	1	—	2.9	3.2	3.5	V	
2	Hysteresis width	V_{HYS}	1	—	60	—	400	mV	
Error Amplifier Block									
3	Input threshold voltage	V_{TH}	2	Voltage follower	0.72	0.75	0.78	V	
4	Line regulation	V_{dv}	2	Voltage follower $V_{CC} = 3.6\text{ V to }34\text{ V}$	—	2	8	mV	
5	Input current	I_B	3	—	-500	-35	—	nA	
6	High-level output voltage	V_{EH}	3	—	2.0	—	—	V	
7	Low-level output voltage	V_{EL}	3	—	—	—	0.3	V	
PWM Comparator Block									
8	High-level input threshold voltage	V_{DT-H}	4	Duty ratio 100%	1.2	—	—	V	
9	Low-level input threshold voltage	V_{DT-L}	4	Duty ratio 0%	—	—	0.6	V	
10	Input current	I_{DTC}	4	—	-12	-11	-10	μA	
Output Block									
11	Output frequency	f_{OUT}	5	—	185	205	225	kHz	
12	Output duty ratio	D_U	5	$R_{DTC} = 91\text{ k}\Omega$	50	55	60	%	
13	Output saturation voltage	$V_{(SAT)}$	4	$I_O = 50\text{ mA}$	—	0.9	1.2	V	
14	Output leak current	I_{OLE}	4	$V_{CC} = 34\text{ V}$ Duty ratio 0%	—	—	10	μA	
Short-circuit Protection Block									
15	Input threshold voltage	V_{THPC}	6	—	0.7	0.75	0.8	V	
16	Input standby voltage	V_{STBY}	6	—	—	—	120	mV	
17	Input latch voltage	V_{IN}	6	—	—	—	120	mV	
18	Charging current	I_{CHG}	6	—	-1.6	-1.3	-1.0	μA	
Overcurrent Protection Block									
19	Threshold voltage	V_{CLM}	7	—	$V_{CC} - 120$	$V_{CC} - 100$	$V_{CC} - 80$	mV	
The Whole Circuit									
20	Total current consumption1	I_{CC1}	8	—	—	2.4	3.5	mA	

2006-08-24		
Established	Revised	

		Product Standards		AN8013SH	
				Total Pages	Page
		17	9		

■ Electrical Characteristics (Reference values for design) at $V_{CC} = 12\text{ V}$, $C_T = 150\text{ pF}$, $R_T = 15\text{ k}\Omega$

Note) $T_a = 25^\circ\text{C} \pm 2^\circ\text{C}$ unless otherwise specified.

B No.	Parameter	Symbol	Test circuits	Conditions	Reference values			Unit	Notes
					Min	Typ	Max		
Error Amplifier Block									
21	Input threshold voltage temperature characteristics 1	V_{dt1}	2	Voltage follower $T_a = -30\text{ to }25^\circ\text{C}$	—	± 1	—	%	*1
22	Input threshold voltage temperature characteristics 2	V_{dt2}	2	Voltage follower $T_a = 25\text{ to }85^\circ\text{C}$	—	± 1	—	%	*1
23	Output sink current	I_{SINK}	3	$V_{FB} = 0.9\text{ V}$	—	8	—	mA	*1
24	Output source current	I_{SOURCE}	3	$V_{FB} = 0.9\text{ V}$	—	-120	—	μA	*1
25	Open-loop gain	AG	3	—	—	70	—	dB	*1
Output Block									
26	Maximum oscillation frequency	$f_{OUT(MAX)}$	5	$C_T = 120\text{ pF}$, $R_T = 5.1\text{ k}\Omega$	—	500	—	kHz	*1
27	Frequency supply voltage characteristics	f_{dv}	5	$V_{CC} = 3.6\text{ V to }34\text{ V}$	—	± 1	—	%	*1
28	Frequency temperature characteristics 1	f_{dt1}	5	$T_a = -30\text{ to }25^\circ\text{C}$	—	± 3	—	%	*1
29	Frequency temperature characteristics 2	f_{dt2}	5	$T_a = 25\text{ to }85^\circ\text{C}$	—	± 3	—	%	*1
30	RT pin voltage	V_{RT}	4	—	—	0.59	—	V	*1
Short-circuit Protection Block									
31	Comparator threshold voltage	V_{THL}	6	—	—	1.90	—	V	*1
Overcurrent Protection Block									
32	Delay time	t_{DLY}	7	—	—	200	—	ns	*1
The Whole Circuit									
33	Total consumption current 2	I_{CC2}	8	$R_T = 5.1\text{ k}\Omega$	—	3.4	—	mA	*1

Note) *1: The above characteristics are reference values for design of the IC and are not guaranteed by inspection.

If a problem does occur related to these characteristics, Matsushita will respond in good faith to user concerns.

2006-08-24		
Established	Revised	

	<h1>Product Standards</h1>	<h2>AN8013SH</h2>	
		Total Pages	Page
		17	10

■ Test Circuit Diagram

1. Test Circuit 1

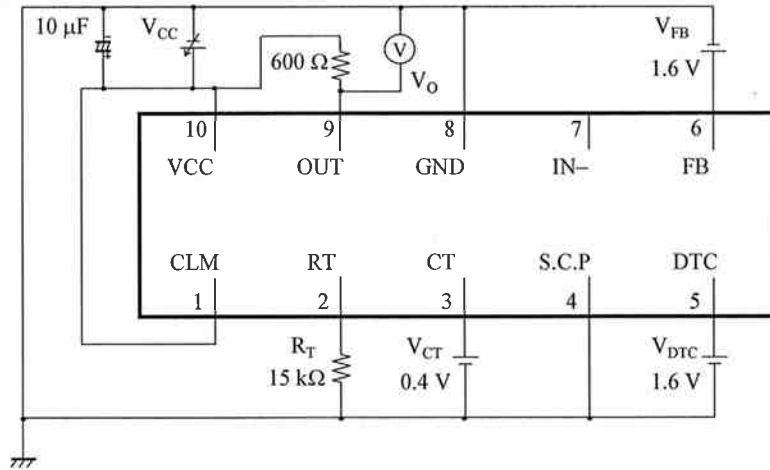

2. Test Circuit 2

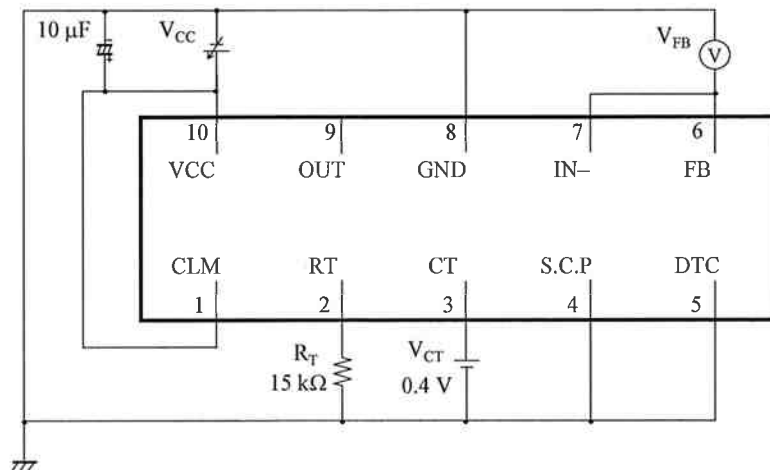

2006-08-24		
Established	Revised	

		AN8013SH	
		Total Pages	Page
		17	11

■ Test Circuit Diagram (continued)

3. Test Circuit 3

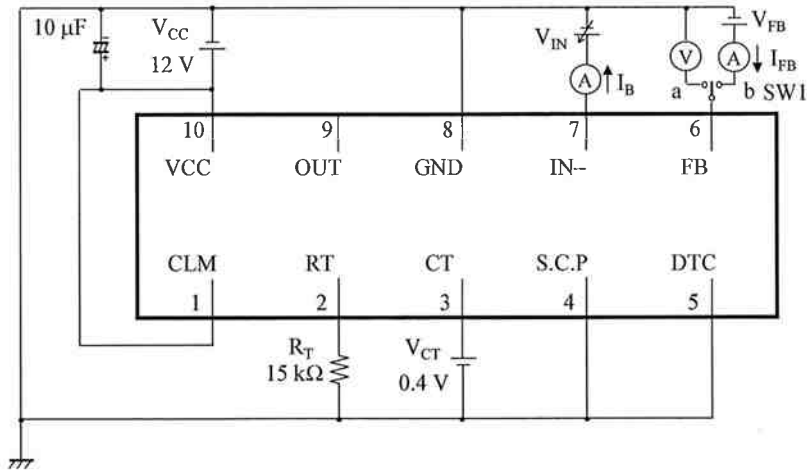

4. Test Circuit 4

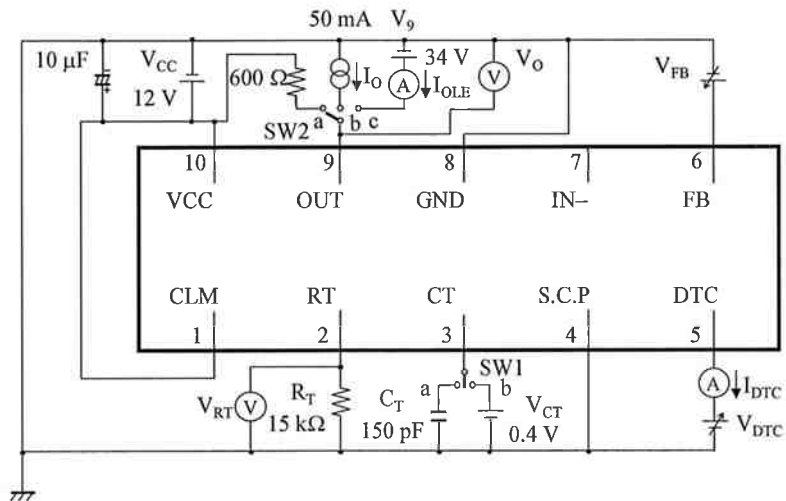

2006-08-24		
Established	Revised	

	<h1>Product Standards</h1>	AN8013SH	
		Total Pages	Page
		17	12

■ Test Circuit Diagram (continued)

5. Test Circuit 5

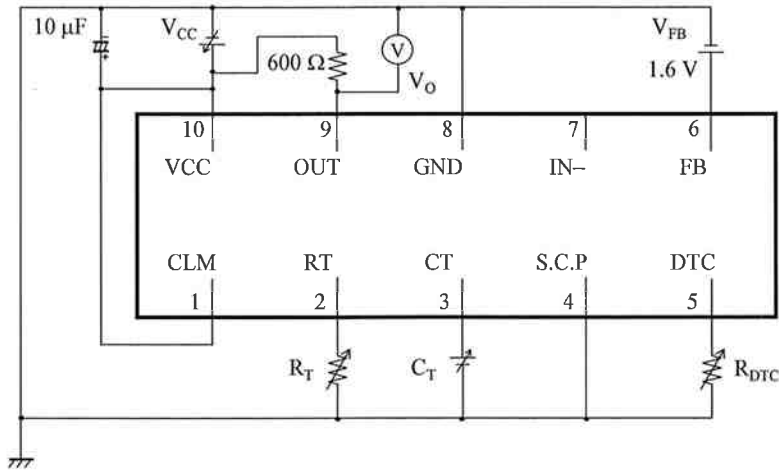

6. Test Circuit 6

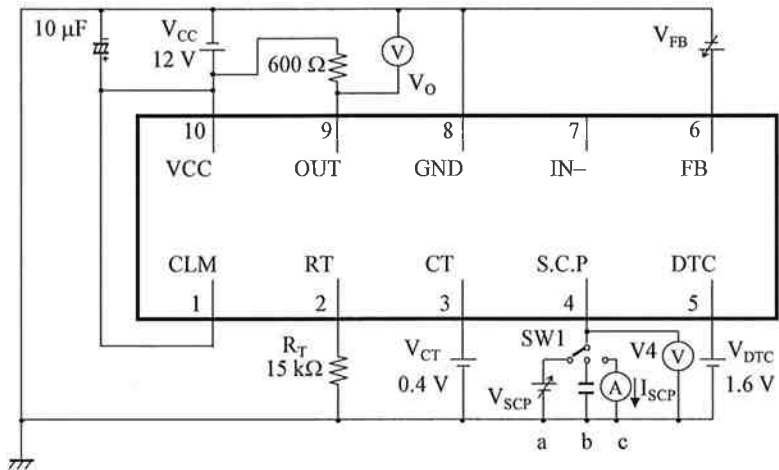

2006-08-24		
Established	Revised	

	<h1>Product Standards</h1>	<h2>AN8013SH</h2>	
		Total Pages	Page
		17	13

■ Test Circuit Diagram (continued)

7. Test Circuit 7

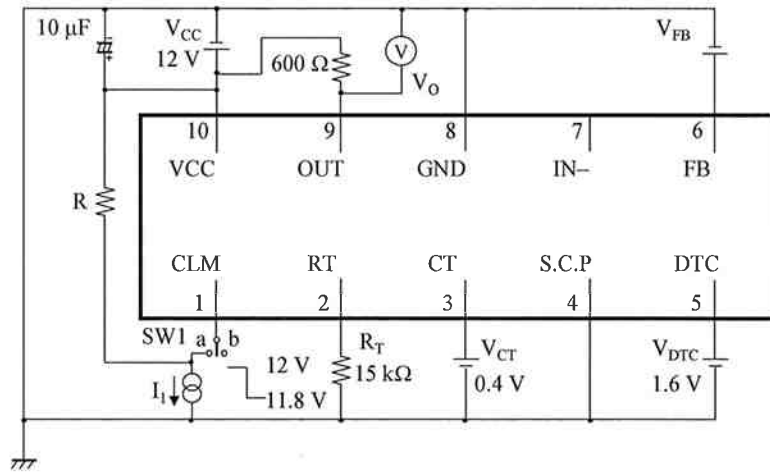

8. Test Circuit 8

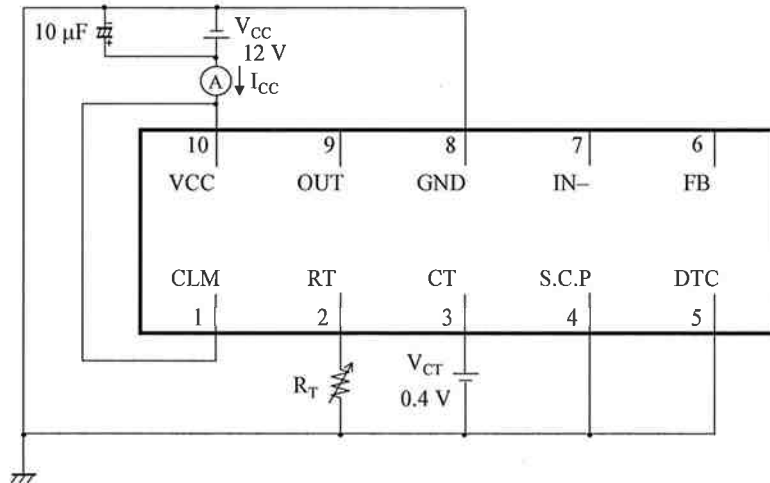

2006-08-24		
Established	Revised	

<h1>Product Standards</h1>		AN8013SH	
		Total Pages	Page
		17	14

■ Electrical Characteristics Test Procedures

1. Test Circuit1

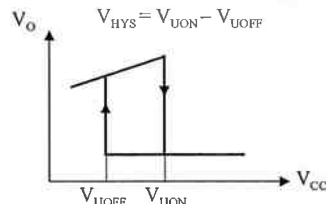
C No.	Parameter	Conditions	Measuring Method
1	U.V.L.O. start voltage	$V_{CT} = 0.3 \text{ V}$, $V_{DTC} = 1.6 \text{ V}$ $V_{FB} = 1.6 \text{ V}$	Measure the V_{CC} voltage when the V_O changes from High to Low level while increasing the V_{CC} voltage gradually.
2	Hysteresis width	$V_{CT} = 0.3 \text{ V}$, $V_{DTC} = 1.6 \text{ V}$ $V_{FB} = 1.6 \text{ V}$	

2. Test Circuit2

C No.	Parameter	Conditions	Measuring Method
3	Input threshold voltage	$V_{CC} = 12 \text{ V}$, $V_{CT} = 0.4 \text{ V}$	Measure the voltage of V_{FB} .
4	Line regulation	$V_{CC} = 3.6 \text{ V to } 34 \text{ V}$, $V_{CT} = 0.4 \text{ V}$	Check the regulation of V_{FB} .
21	Input threshold voltage temperature characteristics 1	$V_{CC} = 12 \text{ V}$, $T_a = -30 \text{ to } 25^\circ\text{C}$	Check the regulation of V_{FB} .
22	Input threshold voltage temperature characteristics 2	$V_{CC} = 12 \text{ V}$, $T_a = 25 \text{ to } 85^\circ\text{C}$	Check the regulation of V_{FB} .

3. Test Circuit3

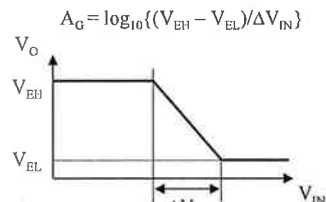
C No.	Parameter	Conditions	Measuring Method
5	Input current	$SW1 = a$, $V_{CC} = 12 \text{ V}$, $V_{CT} = 0.4 \text{ V}$ $V_{IN} = 0.8 \text{ V}$	Measure the current of I_B .
6	High-level output voltage	$SW1 = a$, $V_{CC} = 12 \text{ V}$, $V_{CT} = 0.4 \text{ V}$ $V_{IN} = 0.7 \text{ V}$	Measure the voltage of V_O .
7	Low-level output voltage	$SW1 = a$, $V_{CC} = 12 \text{ V}$, $V_{CT} = 0.4 \text{ V}$ $V_{IN} = 0.8 \text{ V}$	Measure the voltage of V_O .
23	Output sink current	$SW1 = b$, $V_{CC} = 12 \text{ V}$, $V_{CT} = 0.4 \text{ V}$ $V_{IN} = 0.8 \text{ V}$, $V_{FB} = 0.9 \text{ V}$	Measure the current of I_{FB} .
24	Output source current	$SW1 = b$, $V_{CC} = 12 \text{ V}$, $V_{CT} = 0.4 \text{ V}$ $V_{IN} = 0.7 \text{ V}$, $V_{FB} = 0.9 \text{ V}$	Measure the current of I_{FB} .
25	Open-loop gain	$SW1 = a$, $V_{CC} = 12 \text{ V}$, $V_{CT} = 0.4 \text{ V}$	

2006-08-24		
Established	Revised	

<h1 style="margin: 0;">Product Standards</h1>		AN8013SH	
		Total Pages	Page
		17	15

■ Electrical Characteristics Test Procedures (continued)

4. Test Circuit4

C No.	Parameter	Conditions	Measuring Method
8	High-level input threshold voltage	SW1 = a, SW2 = a, V _{CC} = 12 V, V _{FB} = 1.6 V	Measure the voltage of V _{DTC} when the output duty ratio = 100%.
9	Low-level input threshold voltage	SW1 = a, SW2 = a, V _{CC} = 12 V, V _{FB} = 1.6 V	Measure the voltage of V _{DTC} when the output duty ratio = 0%.
10	Input current	SW1 = b, SW2 = a, V _{CC} = 12 V, V _{FB} = 1.6 V, V _{DTC} = 0.2 V	Measure the current of I _{DTC} .
13	Output saturation voltage	SW1 = b, SW2 = b, V _{CC} = 12 V, V _{FB} = 1.6 V, V _{DTC} = 1.6 V	Measure the voltage of V _O .
14	Output leak current	SW1 = b, SW2 = c, V _{CC} = 12 V, V _{FB} = 0 V, V _{DTC} = 0.2 V	Measure the current of I _{OLE} .
30	RT pin voltage	SW1 = b, SW2 = a, V _{CC} = 12 V, V _{FB} = 0 V, V _{DTC} = 1.6 V	Measure the voltage of V _{RT} .

5. Test Circuit5

C No.	Parameter	Conditions	Measuring Method
11	Output frequency	V _{CC} = 12 V, V _{FB} = 1.6 V, R _T = 15 kΩ, C _T = 150 pF, R _{DTC} = 91 kΩ	$f_{OUT} = \frac{1}{T}$ (kHz)
12	Output duty ratio	V _{CC} = 12 V, V _{FB} = 1.6 V, R _T = 15 kΩ, C _T = 150 pF, R _{DTC} = 91 kΩ	$D_U = \frac{t_{ON}}{T} \times 100 (\%)$
26	Maximum oscillation frequency	V _{CC} = 12 V, V _{FB} = 1.6 V, R _T = 15 kΩ, C _T = 120 pF, R _{DTC} = 33 kΩ	$f_{OUT} = \frac{1}{T}$ (kHz)
27	Frequency supply voltage characteristics	V _{CC} = 3.6 V → 34 V, V _{FB} = 1.6 V, R _T = 15 kΩ, C _T = 150 pF, R _{DTC} = 91 kΩ	Check the regulation of f _{OUT} .
28	Frequency temperature characteristics 1	V _{CC} = 12 V, V _{FB} = 1.6 V, R _T = 15 kΩ, C _T = 150 pF, R _{DTC} = 91 kΩ, T _a = -30 to 25°C	Check the regulation of f _{OUT} .
29	Frequency temperature characteristics 2	V _{CC} = 12 V, V _{FB} = 1.6 V, R _T = 15 kΩ, C _T = 150 pF, R _{DTC} = 91 kΩ, T _a = 25 to 85°C	Check the regulation of f _{OUT} .

2006-08-24		
Established	Revised	

<h1>Product Standards</h1>		AN8013SH	
		Total Pages	Page
		17	16

■ Electrical Characteristics Test Procedures (continued)

6. Test Circuit6

C No.	Parameter	Conditions	Measuring Method
15	Input threshold voltage	SW1 = a, $V_{CC} = 12\text{ V}$, $V_{CT} = 0.4\text{ V}$ $V_{DTC} = 1.6\text{ V}$, $V_{FB} = 1.6\text{ V}$	Measure the V_{SCP} voltage when V_O changes from low to high level while increasing the V_{SCP} voltage gradually.
16	Input standby voltage	SW1 = b, $V_{CC} = 12\text{ V}$, $V_{CT} = 0.4\text{ V}$ $V_{DTC} = 1.6\text{ V}$, $V_{FB} = 1.6\text{ V}$	Measure the voltage of V_4 .
17	Input latch voltage	SW1 = b, $V_{CC} = 12\text{ V}$, $V_{CT} = 0.4\text{ V}$ $V_{DTC} = 1.6\text{ V}$, $V_{FB} = 2.0\text{ V}$	Measure the voltage of V_4 .
18	Charging current	SW1 = c, $V_{CC} = 12\text{ V}$, $V_{CT} = 0.4\text{ V}$ $V_{DTC} = 1.6\text{ V}$, $V_{FB} = 2.0\text{ V}$	Measure the current of I_{SCP} .
31	Comparator threshold voltage	SW1 = b, $V_{CC} = 12\text{ V}$, $V_{CT} = 0.4\text{ V}$ $V_{DTC} = 1.6\text{ V}$	Measure the V_{FB} voltage when the V_6 changes from low to high level while increasing the V_{FB} voltage gradually from 1.6 V.

7. Test Circuit7

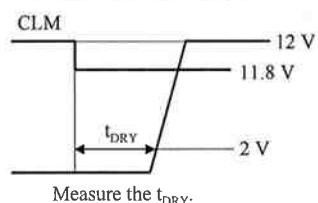
C No.	Parameter	Conditions	Measuring Method
19	Threshold voltage	SW1 = a, $V_{CC} = 12\text{ V}$, $V_{CT} = 0.4\text{ V}$ $V_{DTC} = 1.6\text{ V}$, $V_{FB} = 1.6\text{ V}$	Measure the I_1 current when the V_O changes from low to high level while increasing the I_1 current gradually. $V_{CLM} = I_1 \cdot R$
32	Delay time	SW1 = b, $V_{CC} = 12\text{ V}$, $V_{CT} = 0.4\text{ V}$ $V_{DTC} = 1.6\text{ V}$, $V_{FB} = 1.6\text{ V}$	 <p>Measure the t_{DRY}.</p>

8. Test Circuit8

C No.	Parameter	Conditions	Measuring Method
20	Total consumption current 1	$V_{CC} = 12\text{ V}$, $V_{CT} = 0.4\text{ V}$ $R_T = 15\text{ k}\Omega$	Measure the current of I_{CC} .
33	Total consumption current 2	$V_{CC} = 12\text{ V}$, $V_{CT} = 0.4\text{ V}$ $R_T = 5.1\text{ k}\Omega$	Measure the current of I_{CC} .

2006-08-24		
Established	Revised	

■ Technical Data

- Timing chart

1. Normal operation

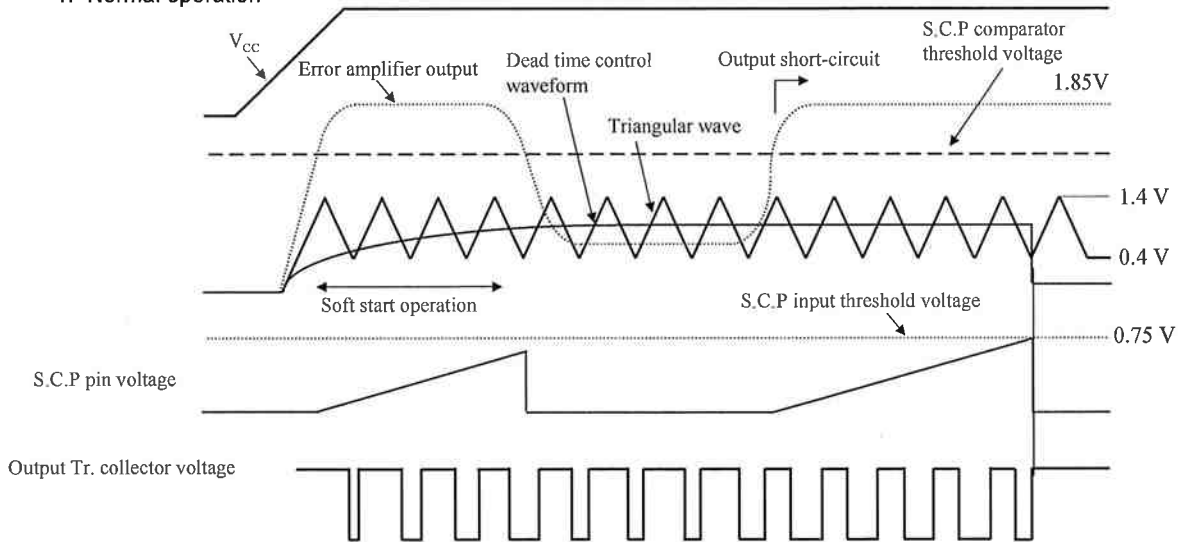

2. Overcurrent protection operation

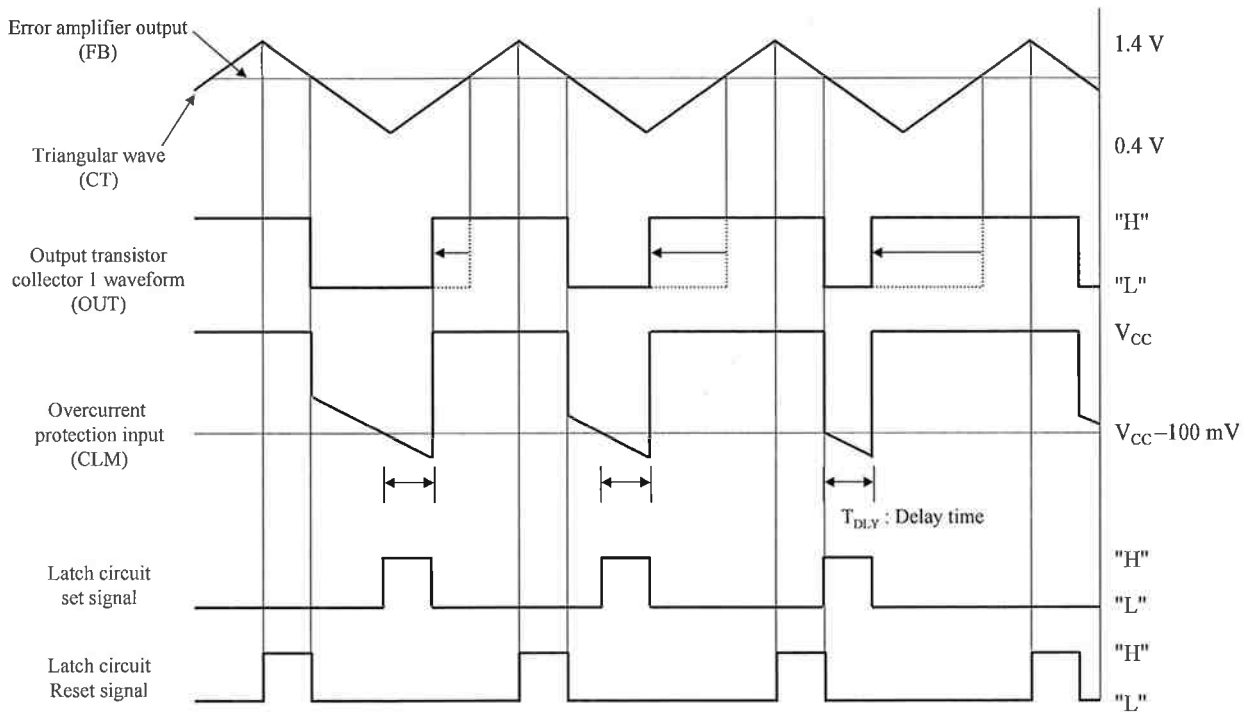

2006-08-24		
Established	Revised	

PACKAGE STANDARDS

Package Code

SSOP010-P-0225A

Semiconductor Company
Matsushita Electric Industrial Co., Ltd.

Established by	Applied by	Checked by	Prepared by
K.Komichi	H.Yoshida	M.Okajima	M.Itoh

	PACKAGE STANDARDS SSOP010-P-0225A		
		Total Pages	Page
		6	2

1. Outline Drawing

Unit:mm

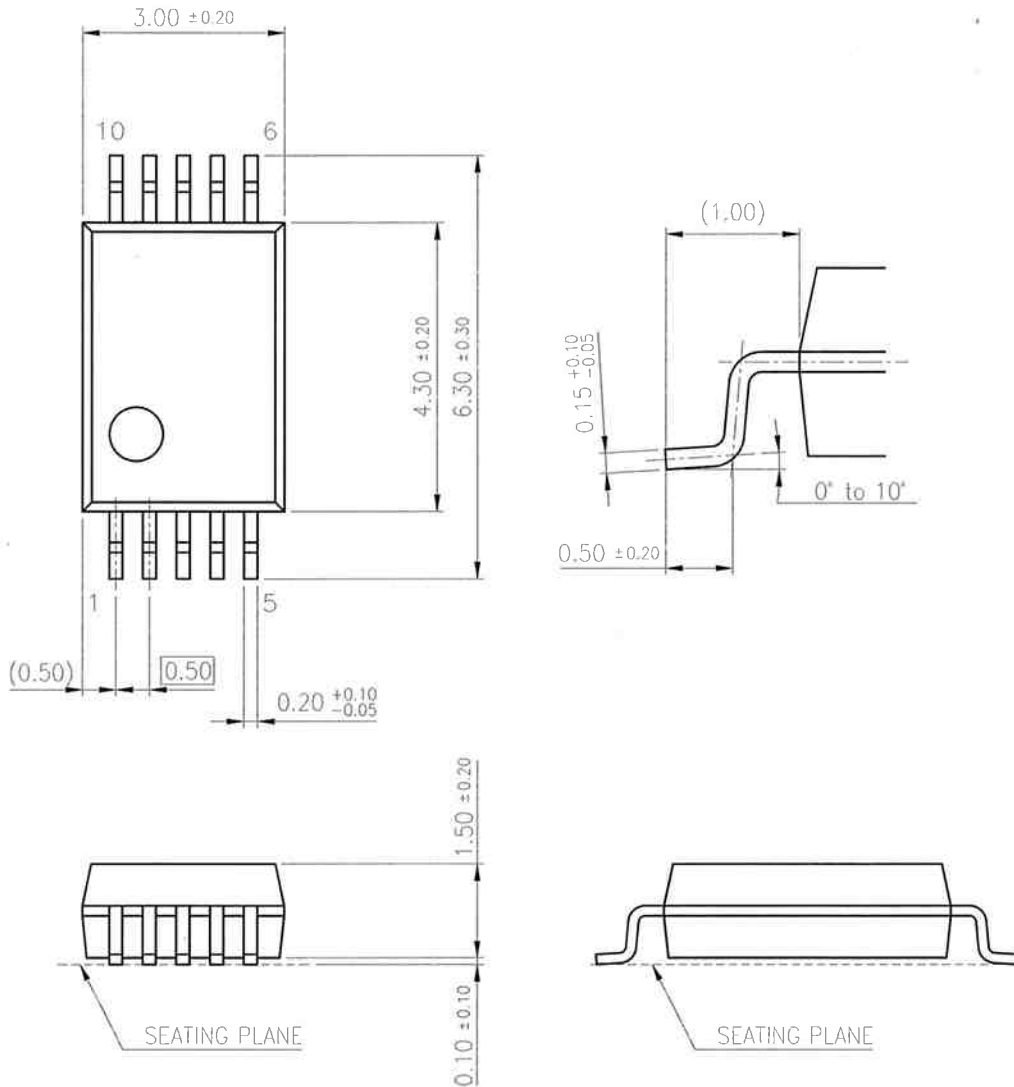

Weight	: 43 mg
Body Material	: Epoxy Resin
Lead Material	: Cu Alloy
Lead Finish Method	: SnBi Plating

--

	PACKAGE STANDARDS SSOP010-P-0225A		
		Total Pages	Page
		6	3

2. Package Structure (Technical Report)

Chip Material	Si	①	
Leadframe material	Cu alloy	②	
Inner lead surface	Ag plating	③	
Outer lead surface	SnBi plating	④	
Chip mount	Method	Resin adhesive method	⑤
	Material	Adhesive material	
Wirebond	Method	Thermo-compression bonding	⑥
	Material	Au	
Molding	Method	Multiplunger molding	⑦
	Material	Epoxy resin	

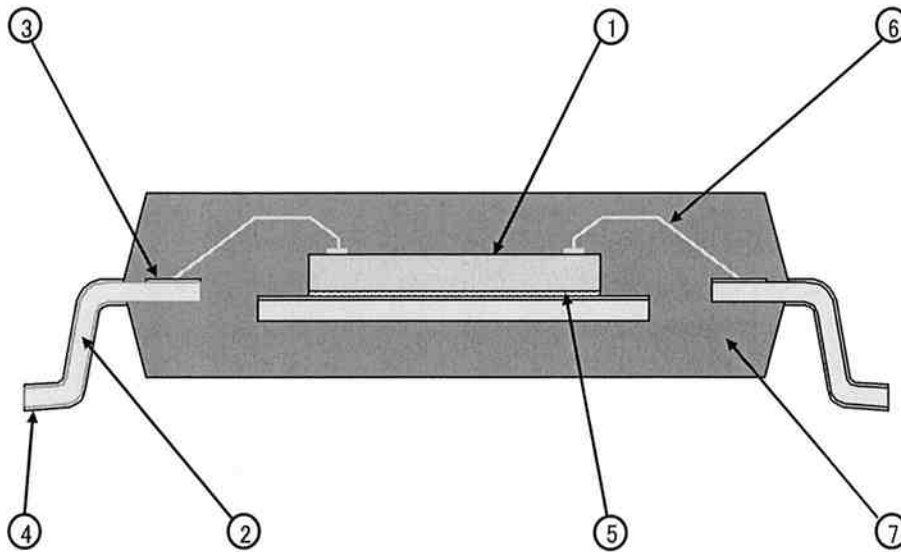

	PACKAGE STANDARDS SSOP010-P-0225A		
		Total Pages	Page
		6	4

3. Mark Drawing

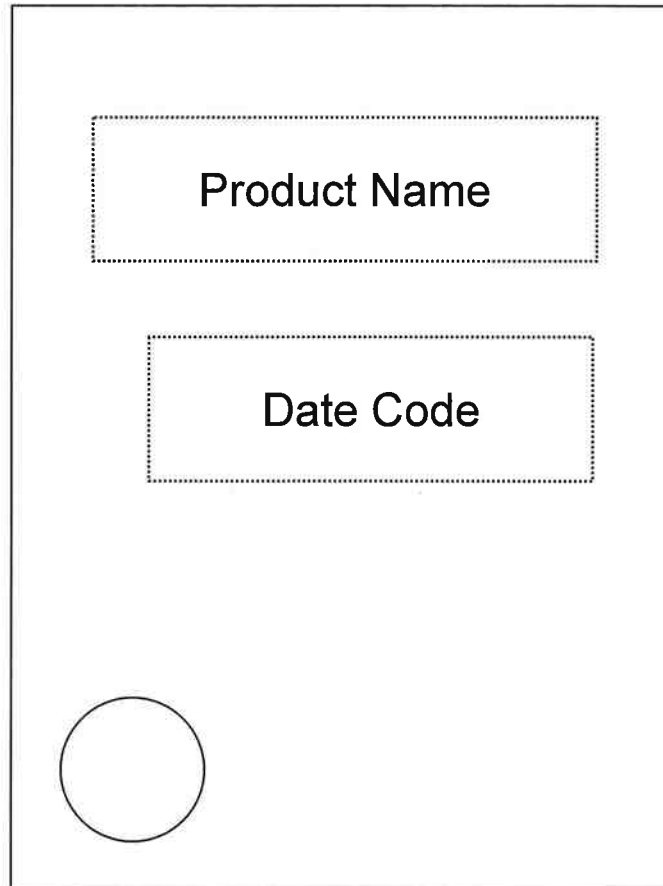

--

4. Power Dissipation (Technical Report)

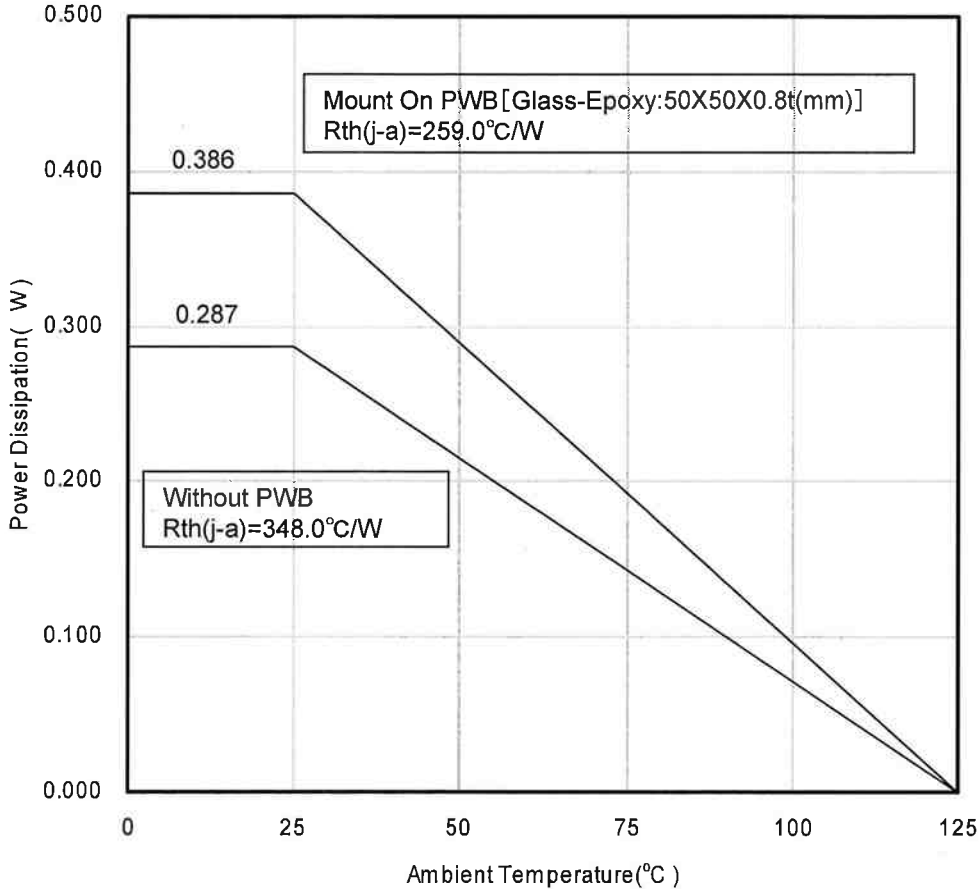

5. Power Dissipation (Supplementary Explanation)

[Experiment environment]

Power Dissipation (Technical Report) is a result in the experiment environment of SEMI standard conformity. (Ambient air temperature (Ta) is 25 degrees C)

[Supplementary information of PWB to be used for measurement]

The supplement of PWB information for Power Dissipation data (Technical Report) are shown below.

Indication	Total Layer	Resin Material
Glass-Epoxy	1-layer	FR-4
4-layer	4-layer	FR-4

[Notes about Power Dissipation (Thermal Resistance)]

Power Dissipation values (Thermal Resistance) depend on the conditions of the surroundings, such as specification of PWB and a mounting condition, and a ambient temperature. (Power Dissipation (Thermal Resistance) is not a fixed value.)

The Power Dissipation value (Technical Report) is the experiment result in specific conditions (evaluation environment of SEMI standard conformity), and keep in mind that Power Dissipation values (Thermal resistance) depend on circumference conditions and also change.

[Definition of each temperature and thermal resistance]

Ta : Ambient air temperature

※The temperature of the air is defined at the position where the convection, radiation, etc. don't affect the temperature value, and it's separated from the heating elements.

Tc : It's the temperature near the center of a package surface. The package surface is defined at the opposite side if the PWB.

Tj : Semiconductor element surface temperature (Junction temperature.)

Rth(j-c) : The thermal resistance (difference of temperature of per 1 Watts) between a semiconductor element junction part and the package surface

Rth(c-a) : The thermal resistance (difference of temperature of per 1 Watts) between the package surface and the ambient air

Rth(j-a) : The thermal resistance (difference of temperature of per 1 Watts) between a semiconductor element junction part and the ambient air

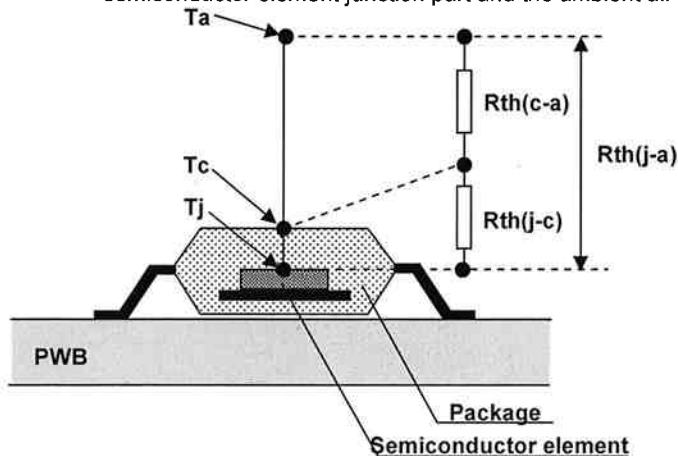

Fig1. Definition image

[Definition formula]

$$Tj = \{Rth(j-c) + Rth(c-a)\} \times P + Ta$$

$$= Rth(j-a) \times P + Ta$$

$$Rth(j-c) = \frac{Tj - Tc}{P} \quad (^\circ C/W)$$

$$Rth(c-a) = \frac{Tc - Ta}{P} \quad (^\circ C/W)$$



$$Rth(j-a) = \frac{Tj - Ta}{P} \quad (^\circ C/W)$$

$$= Rth(j-c) + Rth(c-a)$$





P: power(W)

Looking for pricing, stock, or lifecycle information?

Click below to explore more details on WIN SOURCE:

-  [View AN8013SH-E1 on WIN SOURCE](#)
-  [Panasonic Information](#)

Optimize Your Supply Chain with WIN SOURCE Solutions

-  Global Sourcing Solution
-  Obsolete Management
-  Cost Control Management
-  Shortage Management
-  Alternative Solution
-  Excess Inventory Management