



**THE DATASHEET OF
BQ500110RGZT**



Qi Compliant Wireless Power Transmitter Manager

 Check for Samples: [bq500110](#)

FEATURES

- **Intelligent Control of the Power Transfer between Base Station and Mobile Device**
- **Conforms to Version 1.0 of the Wireless Power Consortium (WPC) Transmitter Specifications**
- **Demodulates and Decodes WPC Complaint Message Packets from the Power Receiving Device Over the Same Wireless Link that Transfers Electrical Power**
- **Implements Closed-Loop Power Transfer PID Control by Varying Frequency of the Voltage on the Transmitting Coil**
- **Parasitic Metal Object Detection (PMOD)**
- **Operating Modes Status Indicators**
 - Standby
 - Power Transfer
 - Charge Complete
 - Fault
- **Overload and Over Temperature Protection**

APPLICATIONS

- **WPC 1.0 Compliant Wireless Chargers for:**
 - Mobile and Smart Phones
 - MP3 Players
 - Global Positioning Devices
 - Digital Cameras
- **Other Wireless Power Base Stations and Transmitters in:**
 - Cars and Other Vehicles
 - Hermetically Sealed Devices, Tools and Appliances
 - Furniture Built-in Wireless Chargers
 - Toy Power Supplies and Chargers

DESCRIPTION

The bq500110 is the industry's first wireless power dedicated digital controller that integrates most of the logic functions required to control Wireless Power Transfer in a single channel WPC compliant contactless charging base station. The bq500110 is an intelligent device that periodically pings the surrounding environment for available devices to be powered; monitors all communication from the mobile device being wirelessly powered; adjusts power applied to the transmitter coil per feedback received from the powered device. The bq500110 also manages fault conditions associated with power transfer and controls the operating modes status indicator. The bq500110 is also the first wireless power controller with parasitic metal object detection that in real time analyzes efficiency of the established power transfer and protects itself and the power receiver from excessive power loss and heat associated with parasitic metal objects placed in the power transfer path.

The bq500110 comes in the area saving 48-pin, 7mm x 7mm QFN package and operates over temperature range from -40°C to 110°C .

ORDERING INFORMATION⁽¹⁾

OPERATING TEMPERATURE RANGE, T _A	ORDERABLE PART NUMBER	PIN COUNT	SUPPLY	PACKAGE	TOP SIDE MARKING
-40°C to 110°C	bq500110RGZR	48 pin	Reel of 2500	QFN	bq500110
	bq500110RGZT	48 pin	Reel of 250	QFN	bq500110

(1) For the most current package and ordering information, see the Package Option Addendum at the end of this document, or see the TI web site at www.ti.com.



Please be aware that an important notice concerning availability, standard warranty, and use in critical applications of Texas Instruments semiconductor products and disclaimers thereto appears at the end of this data sheet.

bq500110

SLUSAE0A – NOVEMBER 2010 – REVISED APRIL 2011

www.ti.com



These devices have limited built-in ESD protection. The leads should be shorted together or the device placed in conductive foam during storage or handling to prevent electrostatic damage to the MOS gates.

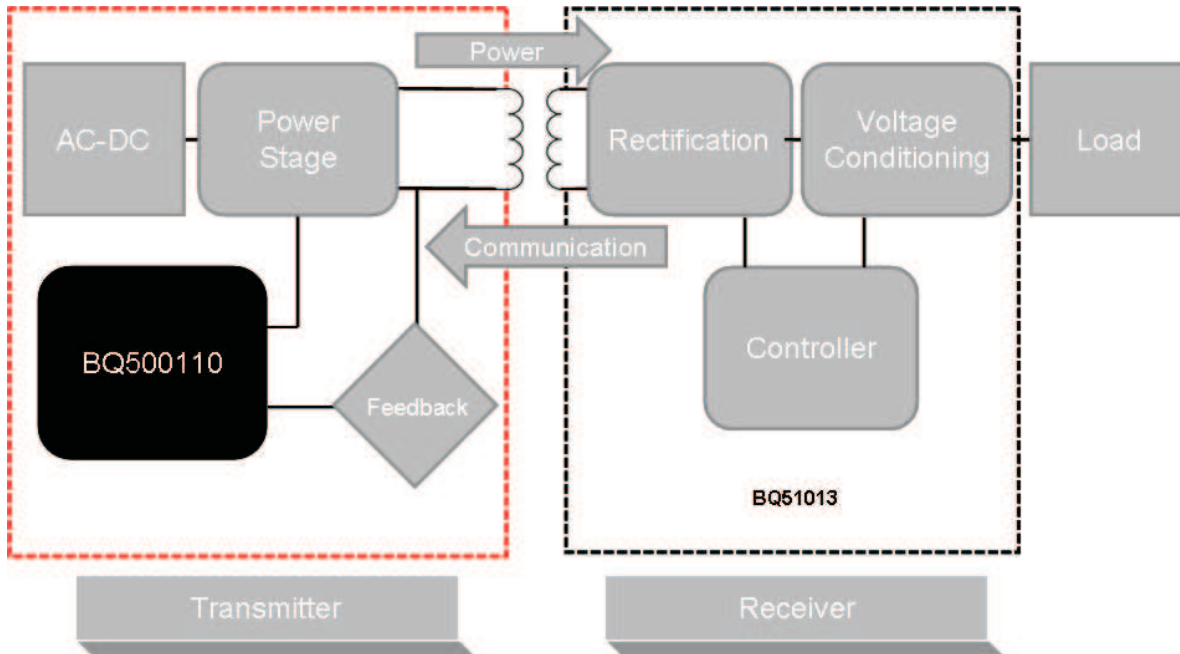

ABSOLUTE MAXIMUM RATINGS⁽¹⁾

over operating free-air temperature range (unless otherwise noted)

	VALUE		UNIT
	MIN	MAX	
Voltage applied at V33D to DGND	-0.3	3.8	V
Voltage applied at V33A to AGND	-0.3	3.8	V
Voltage applied to any pin ⁽²⁾	-0.3	3.8	V
Storage temperature, T _{STG}	-40	150	°C

(1) Stresses beyond those listed under *absolute maximum ratings* may cause permanent damage to the device. These are stress ratings only and functional operation of the device at these or any other conditions beyond those indicated under *recommended operating conditions* is not implied. Exposure to absolute-maximum-rated conditions for extended periods may affect device reliability.

(2) All voltages referenced to GND.

RECOMMENDED OPERATING CONDITIONS

over operating free-air temperature range (unless otherwise noted)

	MIN	NOM	MAX	UNIT
V Supply voltage during operation, V33D, V33A	3.0	3.3	3.6	V
T _A Operating free-air temperature range ⁽¹⁾	-40		125	°C
T _J Junction temperature ⁽¹⁾			125	°C

(1) When operating continuously, the bq500110's typical power consumption causes a 15°C temperature rise from ambient.

ELECTRICAL CHARACTERISTICS

over operating free-air temperature range (unless otherwise noted)

PARAMETER		TEST CONDITIONS	MIN	NOM	MAX	UNIT
SUPPLY CURRENT						
I_{V33A}	Supply current	V33A = 3.3 V		8	15	mA
I_{V33D}		V33D = 3.3 V		42	55	
I_{V33D}		V33D = 3.3 V while storing configuration parameters in flash memory		53	65	
INTERNAL REGULATOR CONTROLLER INPUTS/OUTPUTS						
V33	3.3-V linear regulator	Emitter of NPN transistor	3.25	3.3	3.6	V
V33FB	3.3-V linear regulator feedback			4	4.6	
I_{V33FB}	Series pass base drive	$V_{IN} = 12$ V; current into V33FB pin		10		mA
Beta	Series NPN pass device		40			
EXTERNALLY SUPPLIED 3.3 V POWER						
V33D	Digital 3.3-V power	$T_A = 25^\circ\text{C}$	3		3.6	V
V33A	Analog 3.3-V power	$T_A = 25^\circ\text{C}$	3		3.6	V
V33Slew	V33 slew rate	V33 slew rate between 2.3V and 2.9V, V33A = V33D	0.25			V/ms
MODULATION AMPLIFIER INPUTS EAP-A, EAN-A, EAP-B, EAN-B						
V_{CM}	Common mode voltage each pin		-0.15		1.631	V
EAP-EAN	Modulation voltage digital resolution			1		mV
R_{EA}	Input Impedance	Ground reference	0.5	1.5	3	M Ω
I_{OFFSET}	Input offset current	1 k Ω source impedance	-5		5	μA
ANALOG INPUTS V_{IN}, I_{IN}, $TEMP_{IN}$, I_{COIL}, LED_{MODE}, $PMOD_{THR}$						
V_{ADDR_OPEN}	Voltage indicating open pin	LED_{MODE} , $PMOD_{THR}$ open	2.37			V
V_{ADDR_SHORT}	Voltage indicating pin shorted to GND	LED_{MODE} , $PMOD_{THR}$ shorted to ground			0.36	V
V_{ADC_RANGE}	Measurement range for voltage monitoring	Inputs: V_{IN} , I_{IN} , $TEMP_{IN}$, I_{COIL}	0		2.5	V
INL	ADC integral nonlinearity		-2.5		2.5	mV
I_{Ikg}	Input leakage current	3V applied to pin			100	nA
R_{IN}	Input impedance	Ground reference	8			M Ω
C_{IN}	Input capacitance				10	pF
DIGITAL INPUTS/OUTPUTS						
V_{OL}	Low-level output voltage	$I_{OL} = 6$ mA ⁽¹⁾ , V33D = 3 V			DGND 1 +0.25	V
V_{OH}	High-level output voltage	$I_{OH} = -6$ mA ⁽²⁾ , V33D = 3 V		V33D -0.6V		V
V_{IH}	High-level input voltage	V33D = 3V	2.1		3.6	V
V_{IL}	Low-level input voltage	V33D = 3.5 V			1.4	V
$I_{OH(MAX)}$	Output high source current				4	mA
$I_{OL(MAX)}$	Output low sink current				4	mA
SYSTEM PERFORMANCE						
V_{RESET}	Voltage where device comes out of reset	V33D Pin	2.3		2.4	V
t_{RESET}	Pulse width needed for reset	RESET pin	2			μs
F_{SW}	Switching Frequency		110		205	kHz
t_{detect}	Time to detect presence of device requesting power				0.6	sec
$t_{retention}$	Retention of configuration parameters	$T_J = 25^\circ\text{C}$	100			Years
Write_Cycles	Number of nonvolatile erase/write cycles	$T_J = 25^\circ\text{C}$	20			K cycles

- (1) The maximum I_{OL} , for all outputs combined, should not exceed 12 mA to hold the maximum voltage drop specified.
- (2) The maximum I_{OH} , for all outputs combined, should not exceed 48 mA to hold the maximum voltage drop specified.
- (3) With default device calibration. PMBus calibration can be used to improve the regulation tolerance.
- (4) Time from close of error ADC sample window to time when digitally calculated control effort (duty cycle) is available. This delay must be accounted for when calculating the system dynamic response. Includes EADC conversion time.

bq500110

SLUSAE0A – NOVEMBER 2010 – REVISED APRIL 2011

www.ti.com

DEVICE INFORMATION

Functional Block Diagram

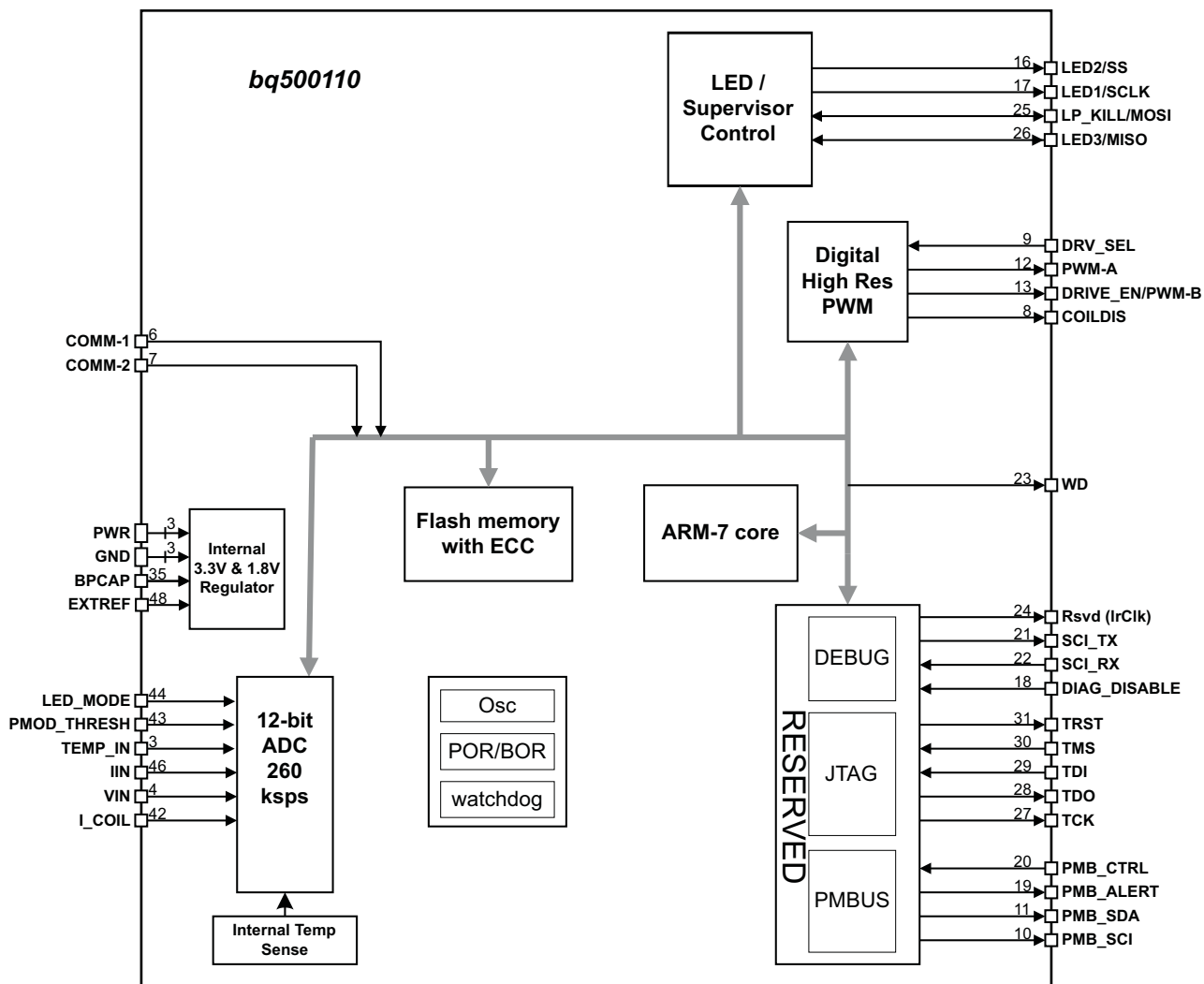

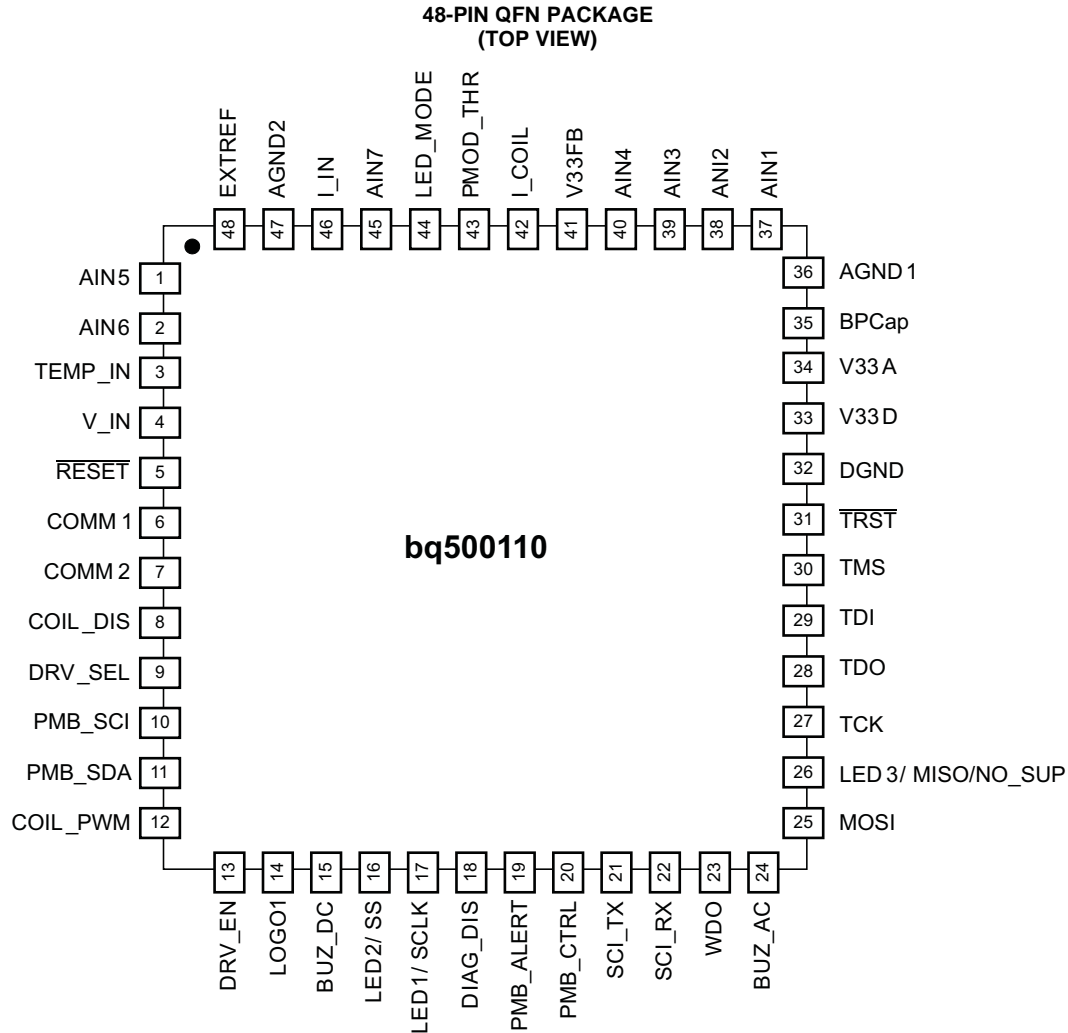

PIN FUNCTIONS

PIN		I/O	DESCRIPTION
NO.	NAME		
1	AIN5	I	Connect this pin to GND
2	AIN6	I	Connect this pin to GND
3	TEMP_IN	I	Thermal protection Input
4	V_IN	I	Input-voltage ADC Input
5	$\overline{\text{RESET}}$	I	Device reset
6	COMM1	I	Primary communication channel
7	COMM2	I	Alternate communication channel
8	COIL_DIS	I	Coil disable
9	DRV_SEL	I	Gate Driver mode select
10	PMB_SCI	I/O	Optional programming I/O. Pull up to V_{CC} via 5.1k Ω resistor.
11	PMB_SDA	I/O	Optional programming I/O. Pull up to V_{CC} via 5.1k Ω resistor.
12	COIL_PWM	O	PWM Output
13	DRV_EN	O	PWM Enable Output
14	LOGO1	O	Optional Logic Output. Leave this pin floating.
15	BUZ_DC	O	DC Buzzer Output
16	LED2 / SS	O	LED Drive Output 2 / Slave Select output

PIN FUNCTIONS (continued)

PIN		I/O	DESCRIPTION
NO.	NAME		
17	LED1 / SCLK	O	LED Drive Output 1 / Serial Clock Output
18	DIAG_DIS	I/O	Disable Diagnostic Output. Leave this pin floating to inhibit diagnostic.
19	PMB_ALERT	I/O	Optional Programming I/O. Connect to GND.
20	PMB_CTRL	I/O	Optional programming I/O. Pull up to V _{CC} via 5.1kΩ resistor.
21	SCI-TX	I/O	Optional Programming I/O. Leave floating.
22	SCI-RX	I/O	Optional Programming I/O. Leave floating.
23	WDO	O	External Watchdog Output
24	BUZ_AC	O	AC Buzzer Output
25	MOSI	I/O	Master Out Slave In
26	LED3/MISO/NO_SUP	I/O	LED Drive Output 3 / Master In Slave Out / Select stand alone operation (no supervisor)
27	TCK	I/O	Optional Programming I/O. Leave floating.
28	TDO	I/O	Optional Programming I/O. Leave floating.
29	TDI	I/O	Optional programming I/O. Pull up to V _{CC} via 5.1kΩ resistor.
30	TMS	I/O	Optional programming I/O. Pull up to V _{CC} via 5.1kΩ resistor.
31	$\overline{\text{TRST}}$	I/O	Optional programming I/O. Pull to GND via 10kΩ resistor.
32	DGND	—	Digital GND
33	V33D	—	Digital Core 3.3V Supply
34	V33A	—	Analog 3.3V Supply
35	BPCAP	—	1.8V Bypass Capacitor Connect Pin
36	AGND	—	Analog GND
37	AN1	I	Reserved Analog Input. Connect this pin to GND.
38	AN2	I	Reserved Analog Input. Connect this pin to GND.
39	AN3	I	Reserved Analog Input. Connect this pin to GND.
40	AN4	I	Reserved Analog Input. Connect this pin to GND.
41	V33FB	I	3.3V Linear-Regulator Feedback Input. Leave this pin floating.
42	I_COIL	I	Coil Current Input
43	PMOD_THR	I	Input to Program Parasitic Metal Object Detection Threshold
44	LED_MODE	I	Input to Select LED Mode
45	AIN7	I	Reserved Analog Input. Connect this pin to GND.
46	I_IN	I	Transmitter Input Current
47	AGN2	—	Analog GND 2.
48	EXTREF	I	External Reference Voltage Input. Connect this Input to GND.

TYPICAL CHARACTERISTICS

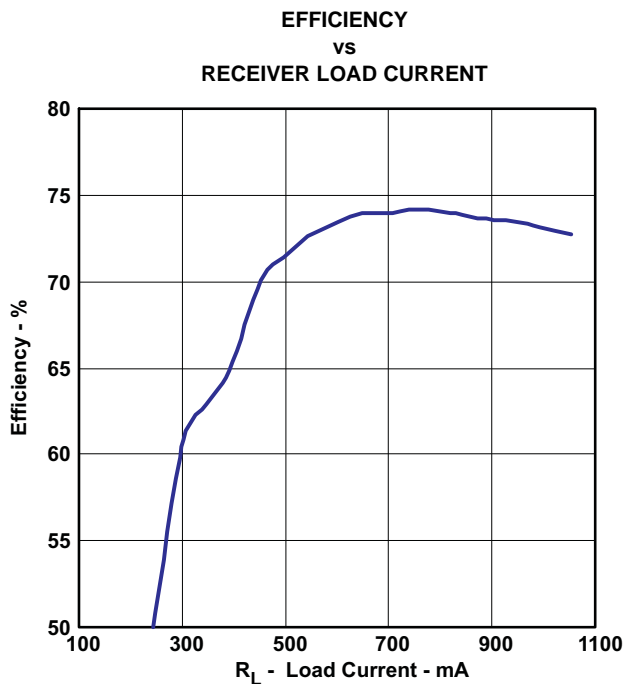

Figure 1.

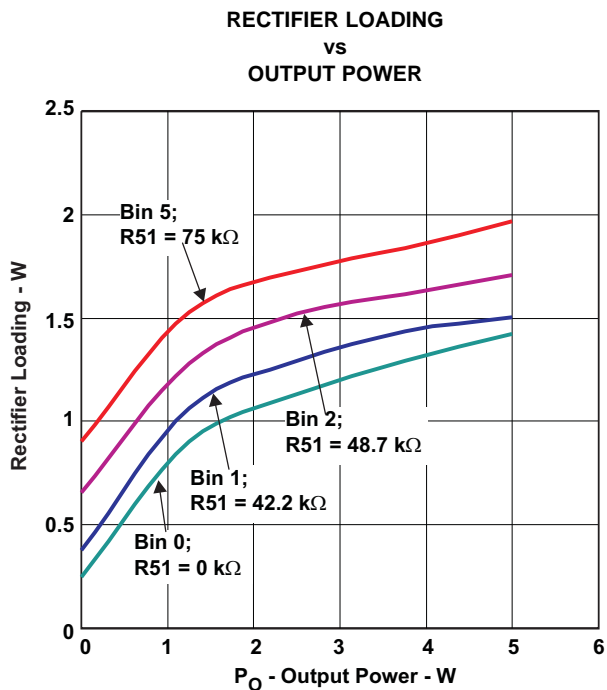

Figure 2.

FUNCTIONAL OVERVIEW

The typical Wireless Power Transfer System consists of the primary and the secondary coils that are positioned against each other in the way to maximize mutual coupling of their electromagnetic fields. Both coils have ferrite shields as parts of their structure to even further maximize field coupling. The primary coil is excited with the switching waveform of the transmitter power driver that gets its power from AC-DC wall adapter. The secondary coil is connected to the rectifier that can either directly interface the battery or can have an electronic charger or post-regulator connected to its output. The capacitors in series with the coils are tuned to create resonance in the system. The system being in resonance facilitates better energy transfer compared to the inductive transfer. Power transfer in the resonant system can also be easier controlled with the variable frequency control approach.

The rectifier output voltage is monitored by the secondary side microcontroller that generates signals to control modulation circuit to pass coded information from the secondary side to the primary side. The coded information is organized into information packets that have Preamble bytes, Header bytes, message bytes and the Checksum bytes. Per WPC standard information packets can be related to Identification, Configuration, Control Error, Rectified Power, Charge Status and End of Power Transfer. For detailed information on WPC standard visit Wireless Power Consortium web site at <http://www.wirelesspowerconsortium.com/>.

There are two ways the coupled electromagnetic field can be manipulated to achieve information transfer from the secondary side to the primary side. With resistive modulation approach shown in Figure 3, the communication resistor periodically loads the rectifier output changing system Q factor and as a result value of the voltage on the primary side coil. With capacitive modulation approach shown in Figure 4 a pair of communication capacitors are periodically connected to the receiver coil network. These extra capacitance application changes slightly the resonance frequency of the system and its response on the current operating frequency, which in turn leads to coil voltage variation on the primary side.

With both modulation techniques primary side coil voltage variations are detected with demodulation circuit and further interpreted in bq500110 to restore the content of the information packets and adjust controls to the transmitter schematic.

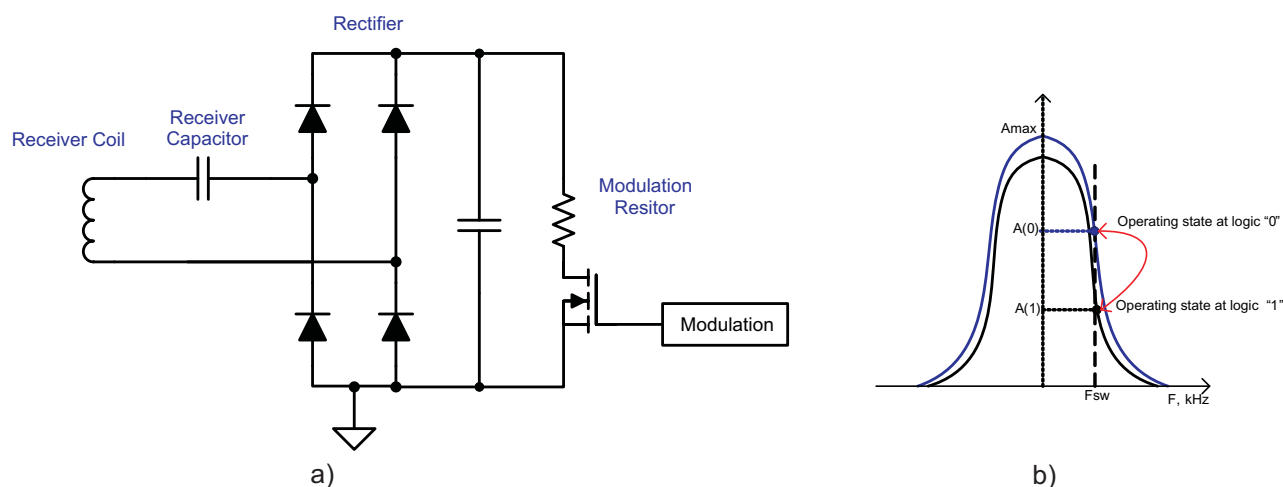

Figure 3. Resistive Modulation Circuit

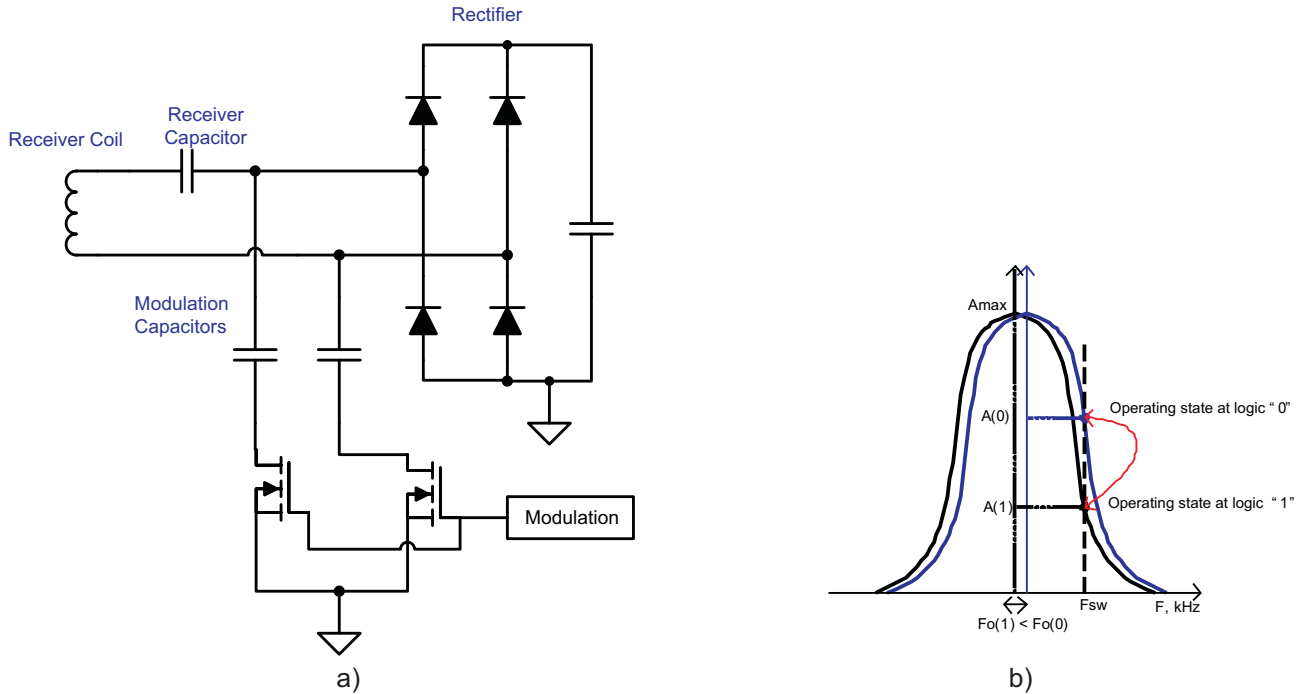

Figure 4. Capacitive Modulation Circuit

The bq500110 is the industry's first wireless power dedicated transmitter controller that simplifies integration of wireless power technology in consumer electronics, such as digital cameras, smart phones, MP3 players and global positioning systems, along with infrastructure applications such as furniture and cars.

The bq500110 is a specialized digital power microcontroller that controls WPC A1, single coil, transmitter functions such as analog ping, digital ping, variable frequency output power control, parasitic metal object detection, protection against transmitter coil over-current, over temperature protection of the transmitter top surface, and indication of the transmitter states of operation.

The bq500110 digital inputs receive and interpret signals from the analog demodulator circuit that provides first stage of demodulation for digital commands sent by the WPC compliant Receiver. Based on the received commands the controller provides control signals to the transmitter coil half-bridge power-driver. The controller analog inputs monitor input DC voltage, Input Current, the Coil Current and the Thermal Protection input. These analog inputs support monitoring and protective functions of the controller.

The bq500110 directly controls two LEDs to indicate the controller standby, power transfer, PMOD warning, PMOD-stop and system fault states.

Option Select Pins

Two pins in bq500110 are allocated to program the LED mode and the PMOD mode of the device. At power-up, a bias current is applied to pins LED_MODE and PMOD_THR and the resulting voltage measured in order to identify the value of the attached programming resistor. The values of the operating parameters set by these pins are determined using [Option Select Bins](#). For LED_MODE the selected bin determines the LED behavior based on [LED Modes](#); for the PMOD_THR the selected bin sets a threshold used for parasitic metal object detection (see [Metal Object Detection \(MOD\)](#) section).

bq500110

SLUSAE0A –NOVEMBER 2010–REVISED APRIL 2011

www.ti.com

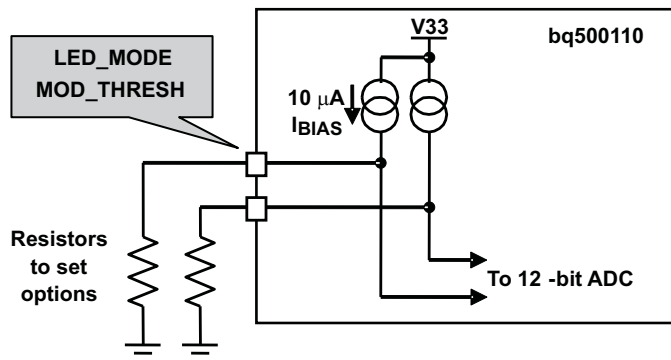

Figure 5. Option Programming

Table 1. Option Select Bins

BIN NUMBER	RESISTANCE (kΩ)	LED OPTION	PMD THRESHOLD (mW)
0	GND	0	1400
1	42.2	1	1500
2	48.7	2	1600
3	56.2	3	1700
4	64.9	4	1800
5	75.0	5	1900
6	86.6	6	2000
7	100	7	2100
8	115	8	2200
9	133	9	2300
10	154	10	2400
11	178	11	2500
12	205	12	2600
13	open	13	OFF

LED Modes

The bq500110 can directly control up to three LED outputs. They are driven based on one of twelve selectable modes. Using the resistor of the 44 pin to GND select one of the desired LED Indication scheme presented in [Table 2](#).

Table 2. LED Modes

LED Control Option	I/O	Supervisory Register	Recommended LED Colors	Operational States										Fault Blink Period (ON time + OFF time) (ms)	PLD Blink Period (ON time + OFF time) (ms)	Operating Blink Period (ON time + OFF time) (ms)	Initialization Delay (holds LED state at Init)	Remarks
				Initialization	Uses Operating Blink Rate			PLD Blink	Uses Fault Blink Rate			Diag LED On	Diag LED Off					
					Standby	Power Xfer	Charged		PLD Fault	Dev Fault	Sys Fault							
0	26	LED1	Red	ON	ON	OFF	OFF	ON	ON	ON	ON	ON	OFF	200	200	2000	1000	Reserved for support of "legacy" hardware, uses NVM to define LED activity. NOTE: Uses active HIGH LED drive!
	16	LED2	Green	ON	ON	Blink	ON	OFF	OFF	OFF	OFF	ON	OFF					
	17	LED3	Red (Pilot)	ON	ON	ON	ON	ON	ON	ON	ON	ON	ON					
	n/a	n/a	Pilot (Blue)	x	x	x	x	x	x	x	x	x	x					
1	17	LED1	x	x	x	x	x	x	x	x	x	x	x	x	x	x	x	Reserved for future custom implementations, LED activity defined by NVM.
	16	LED2	x	x	x	x	x	x	x	x	x	x	x					
	26	LED3	x	x	x	x	x	x	x	x	x	x	x					
	n/a	n/a	Pilot (Blue)	ON	ON	ON	ON	ON	ON	ON	ON	ON	ON					
2	17	LED1	Green	OFF	OFF	ON	Blink	Blink	Blink	Blink	Blink	ON	OFF	200	200	2000	0	Simplest, generic single LED indication scheme that signals Power Xfer and End of Charge. Optional Pilot Power indicator is of any color other than Green
	16	LED2	not used	OFF	OFF	OFF	OFF	OFF	OFF	OFF	OFF	OFF	OFF					
	26	LED3	not used	OFF	OFF	OFF	OFF	OFF	OFF	OFF	OFF	OFF	OFF					
	n/a	n/a	Pilot (Blue)	ON	ON	ON	ON	ON	ON	ON	ON	ON	ON					
3	17	LED1	Red	OFF	OFF	ON	OFF	ON	ON	ON	Blink	ON	OFF	200	200	N/A	0	Simplest, generic dual LED indication scheme that signals Power Xfer and End of Charge. Optional Pilot Power indicator is of any color other than Green and Red.
	16	LED2	Green	OFF	OFF	ON	ON	OFF	OFF	OFF	Blink	ON	OFF					
	26	LED3	not used	OFF	OFF	OFF	OFF	OFF	OFF	OFF	OFF	OFF	OFF					
	n/a	n/a	Pilot (Blue)	ON	ON	ON	ON	ON	ON	ON	ON	ON	ON					
4	17	LED1	Red	ON	ON	OFF	OFF	ON	ON	ON	ON	ON	OFF	200	200	2000	0	
	16	LED2	Green	ON	ON	Blink	ON	OFF	OFF	OFF	OFF	ON	OFF					
	26	LED3	not used	OFF	OFF	OFF	OFF	OFF	OFF	OFF	OFF	OFF	OFF					
	n/a	n/a	Pilot (Blue)	ON	ON	ON	ON	ON	ON	ON	ON	ON	ON					

Table 2. LED Modes (continued)

5	17	LED1	Red	OFF	OFF	Blink	OFF	Blink	Blink	Blink	ON	OFF	200	200	2000	0		
	16	LED2	not used	OFF	OFF	OFF	OFF	OFF	OFF	OFF	OFF	OFF						
	26	LED3	not used	OFF	OFF	OFF	OFF	OFF	OFF	OFF	OFF	OFF						
	n/a	n/a	Pilot (Blue)	ON	ON	ON	ON	ON	ON	ON	ON	ON						
6	17	LED1	Red	OFF	OFF	OFF	OFF	Blink	Blink	Blink	Blink	ON	OFF	200	200	2000	0	
	16	LED2	Green	OFF	OFF	Blink	ON	OFF	OFF	OFF	OFF	ON	OFF					
	26	LED3	not used	OFF	OFF	OFF	OFF	OFF	OFF	OFF	OFF	OFF	OFF					
	n/a	n/a	Pilot (Blue)	ON	ON	ON	ON	ON	ON	ON	ON	ON	ON					
7	17	LED1	Red	OFF	OFF	ON	OFF	Blink ⁽¹⁾	Blink	Blink	Blink	ON	OFF	400	2000	2000	0	⁽¹⁾ PLD Blinks Operational Blink.
	16	LED2	Green	OFF	OFF	ON	ON	OFF	OFF	OFF	OFF	ON	OFF					
	26	LED3	not used	OFF	OFF	OFF	OFF	OFF	OFF	OFF	OFF	OFF	OFF					
	n/a	n/a	Pilot (Blue)	ON	ON	ON	ON	ON	ON	ON	ON	ON	ON					
8	17	LED1	Red	OFF	OFF	OFF	OFF	Blink ⁽¹⁾	Blink	Blink	Blink	ON	OFF	400	2000	2000	0	⁽¹⁾ PLD Blinks Operational Blink.
	16	LED2	Green	OFF	OFF	Blink	ON	OFF	OFF	OFF	OFF	ON	OFF					
	26	LED3	not used	OFF	OFF	OFF	OFF	OFF	OFF	OFF	OFF	OFF	OFF					
	n/a	n/a	Pilot (Blue)	ON	ON	ON	ON	ON	ON	ON	ON	ON	ON					
9	17	LED1	Red	ON	ON	OFF	OFF	ON	ON	ON	ON	ON	OFF	200	200	2000	1000	
	16	LED2	Green	ON	ON	Blink	ON	OFF	OFF	OFF	OFF	ON	OFF					
	26	LED3	not used	OFF	OFF	OFF	OFF	OFF	OFF	OFF	OFF	OFF	OFF					
	n/a	n/a	Pilot (Blue)	ON	ON	ON	ON	ON	ON	ON	ON	ON	ON					
10	17	LED1	Red	ON	OFF	Blink	OFF	Blink	Blink	Blink	Blink	ON	OFF	200	200	2000	1000	
	16	LED2	not used	OFF	OFF	OFF	OFF	OFF	OFF	OFF	OFF	OFF	OFF					
	26	LED3	not used	OFF	OFF	OFF	OFF	OFF	OFF	OFF	OFF	OFF	OFF					
	n/a	n/a	Pilot (Blue)	ON	ON	ON	ON	ON	ON	ON	ON	ON	ON					
11	17	LED1	Red	ON	OFF	OFF	OFF	Blink	Blink	Blink	Blink	ON	OFF	200	200	2000	1000	
	16	LED2	Green	OFF	OFF	Blink	ON	OFF	OFF	OFF	OFF	ON	OFF					
	26	LED3	not used	OFF	OFF	OFF	OFF	OFF	OFF	OFF	OFF	OFF	OFF					
	n/a	n/a	Pilot (Blue)	ON	ON	ON	ON	ON	ON	ON	ON	ON	ON					
12	17	LED1	Red	OFF	OFF	ON	OFF	Blink ⁽¹⁾	Blink	Blink	Blink	ON	OFF	400	2000	2000	1000	⁽¹⁾ PLD Blinks Operational Blink.
	16	LED2	Green	ON	OFF	ON	ON	OFF	OFF	OFF	OFF	ON	OFF					
	26	LED3	not used	OFF	OFF	OFF	OFF	OFF	OFF	OFF	OFF	OFF	OFF					
	n/a	n/a	Pilot (Blue)	ON	ON	ON	ON	ON	ON	ON	ON	ON	ON					
13	17	LED1	Red	OFF	OFF	OFF	OFF	Blink ⁽¹⁾	Blink	Blink	Blink	ON	OFF	400	2000	2000	1000	⁽¹⁾ PLD Blinks Operational Blink.
	16	LED2	Green	ON	OFF	Blink	ON	OFF	OFF	OFF	OFF	ON	OFF					
	26	LED3	not used	OFF	OFF	OFF	OFF	OFF	OFF	OFF	OFF	OFF	OFF					
	n/a	n/a	Pilot (Blue)	ON	ON	ON	ON	ON	ON	ON	ON	ON	ON					

Thermal Protection

The bq500110 can provide thermal protection to the transmitter. An external NTC resistor can be placed in the most thermally challenged area, which usually is the center of the transmitting coil, and connected between V_{CC} and the dedicated pin 3. The threshold on the pin 3 is set 1.25V. The NTC resistor and the resistor from the pin 3 to GND create temperature sensitive divider. User has full flexibility choosing the NTC resistor and the value of the resistor from the pin 3 to GND to set the desired temperature when the system shuts down.

$$R_{TEMP_IN} = 0.6097 \times R_{NTC}(T_{MAX}) \quad (1)$$

The system will attempt to restore normal operation after approximately five minutes being in the suspended mode due to tripping the over-temperature threshold, or if the receiver is removed.

Audible Notification on Initiation of Power Transfer

The bq500110 is capable of activating two types of buzzers to indicate that power transfer has begun. Pin 15 outputs a high logic signal for 0.5s which is suitable to activate DC type buzzers with built in tone generation, other types of sound generators, or custom indication systems. Pin 24 outputs a 0.2s, 4000Hz square wave signal suitable for inexpensive AC type ceramic buzzers.

Gate Driver Modes

The inner PID (proportional-integral-derivative) loop feeds the variable frequency driver, which produces a digital signal of 50% duty cycle with variable frequency. In operation, the inner PID loop calculates the necessary frequency, which is then generated by the variable frequency driver. The variable frequency is then fed into a MOSFET power train that excites the serial resonance transmitter coil.

The bq500110 can operate with several types of MOSFET gate drivers to accommodate various power train topologies. The DRV_SEL input, pin 9, selects between two modes of drive. When pin 9 is pulled to GND, the DRV_EN output, pin 13, will be driven high while the COIL_PWM output sends a square waveform to the gate driver. The most typical and suggested solution is to use a synchronous buck driver like the TPS28225 that drives n-channel upper and lower power MOSFETs with a safe dead-time.

An alternative solution that may utilize a combination of p-channel and n-channel MOSFETs can be used when input DRV_SEL input, pin 9, is pulled high to V_{CC} . In this case the outputs COIL_PWM and DRV_EN, both output the square waveforms to discrete gate drivers. The dead-time is provided by pulse duration difference between the two waveforms.

Coil Disable Signal

As the part of the WPC 1.0 compliance communication protocol, the bq500110 has the coil damping control signal that is provided on the output COIL_DIS, pin 8. The damping signal activates the MOSFET that loads the output of the half-bridge with the 100Ω resistor.

Power-On Reset

The bq500110 has an integrated power-on reset (POR) circuit that monitors the supply voltage. At power-up, the POR circuit detects the V33D rise. When V33D is greater than VRESET, the device initiates an internal startup sequence. At the end of the startup sequence, the device begins normal operation.

External Reset

The device can be forced into a reset state by an external circuit connected to the \overline{RESET} pin. A logic low voltage on this pin holds the device in reset. To avoid an erroneous trigger caused by noise, a 10kΩ pull up resistor to 3.3V is recommended.

Non-Volatile Memory Error Correction Coding

The device uses Error Correcting Code (ECC) to improve data integrity and provide high reliability storage of Data Flash contents. ECC uses dedicated hardware to generate extra check bits for the user data as it is written into the Flash memory. This adds an additional six bits to each 32-bit memory word stored into the Flash array. These extra check bits, along with the hardware ECC algorithm, allow for any single bit error to be detected and corrected when the Data Flash is read. Note that the Data Flash configuration has been factory programmed and is not generally available for customization.

bq500110

SLUSAE0A – NOVEMBER 2010 – REVISED APRIL 2011

www.ti.com

Parasitic Metal Object Detection (PMOD)

As a safety feature, the bq500110 can be configured to detect presence of a parasitic metal object placed in the vicinity of the magnetic field. The BQ500100 uses the Rectified Power Packet information and the measured transmitter input-power to calculate parasitic losses in the system. When an excessive power loss is detected the device will lit the red LED to warn about this undesirable condition, If during a twenty second warning time the parasitic metal object was not removed , the controller will disable power transfer. After being in halt for five minutes bq500110 will attempt normal operation. If the object that caused excessive power dissipation is still present, the sequence will be repeated over and over again. If the metal object is removed during this twenty second warning time, the normal operation will be restored momentarily.

To facilitate parasitic loss function, the bq500110 monitors the input voltage and the input current supplied to the coil power drive circuit.

The PMOD_THR pin is used to set the threshold at which the MOD is activated. The MOD operation can be disabled by selecting the highest bin(leaving the pin is left floating).

The threshold is set by [Equation 2](#):

$$\text{Threshold} = 1400 \text{ mW} + \text{Bin_Number} \times 100 \text{ mW} \quad (2)$$

Note: The WPC Specification V1.0 does not define the requirements and thresholds for MOD feature, thus metal object detection may perform differently with different products. Therefore make your own decision when setting the threshold. In most desktop wireless charger applications setting the PMOD threshold to 1.5W shown to give good results in stopping power transfer and preventing small metal objects like coins, pharmaceutical wraps, etc. getting hot when placed in the path of wireless power transfer. [Figure 1](#) depicts PMOD performance measured on bq500110 EVM. .

APPLICATION INFORMATION

Typical application diagrams for the WPC 1.0 compliant transmitter are shown on the following pages.

Not Recommended For New Designs

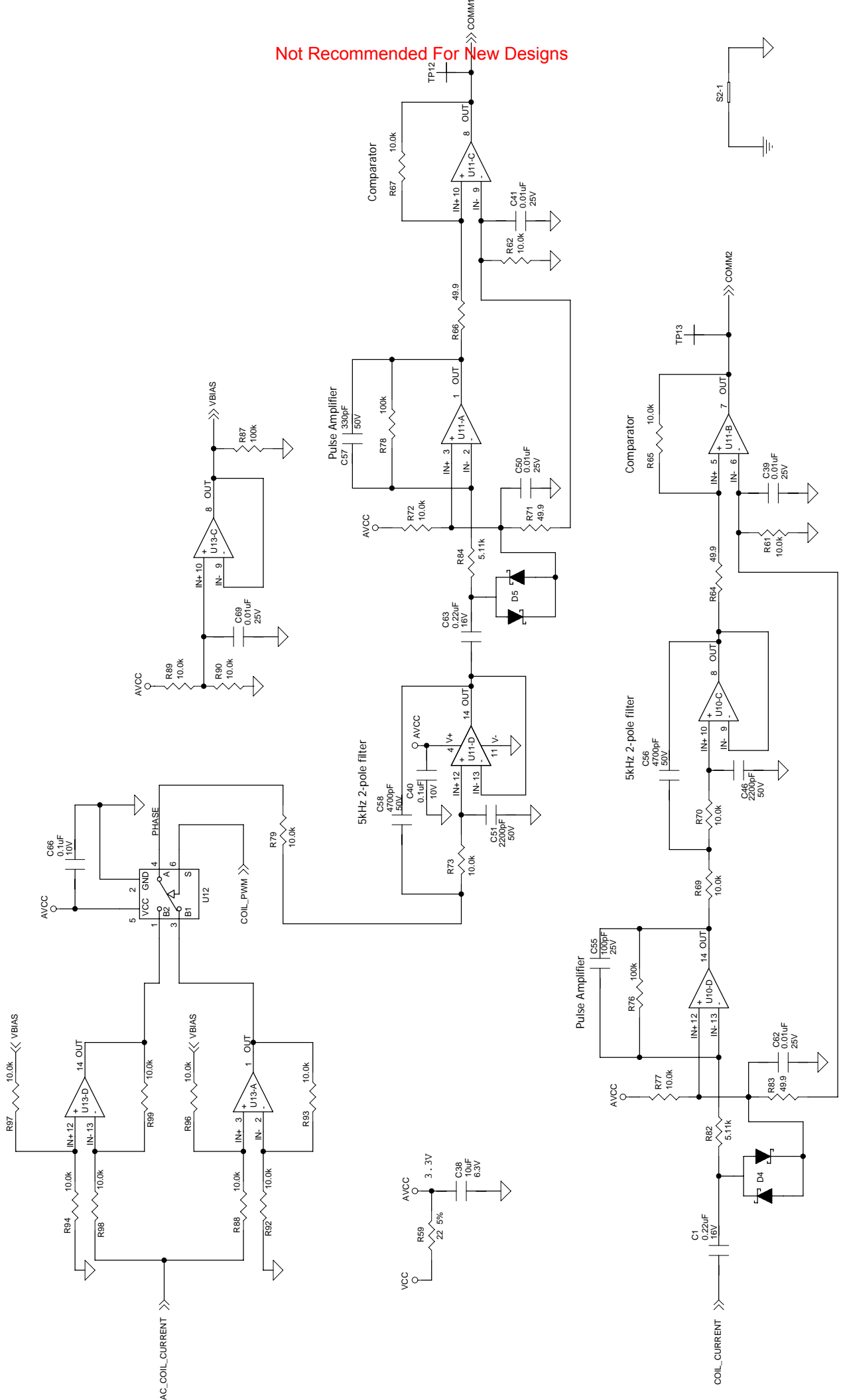

Changes from Original (November 2010) to Revision A**Page**

-
- Updated the data sheet for product release **1**
-

PACKAGING INFORMATION

Orderable Device	Status (1)	Package Type	Package Drawing	Pins	Package Qty	Eco Plan (2)	Lead/Ball Finish (6)	MSL Peak Temp (3)	Op Temp (°C)	Device Marking (4/5)	Samples
BQ500110RGZR	NRND	VQFN	RGZ	48	2500	Green (RoHS & no Sb/Br)	CU NIPDAU	Level-3-260C-168 HR	-40 to 110	BQ500110	
BQ500110RGZT	NRND	VQFN	RGZ	48	250	Green (RoHS & no Sb/Br)	CU NIPDAU	Level-3-260C-168 HR	-40 to 110	BQ500110	

(1) The marketing status values are defined as follows:

ACTIVE: Product device recommended for new designs.

LIFEBUY: TI has announced that the device will be discontinued, and a lifetime-buy period is in effect.

NRND: Not recommended for new designs. Device is in production to support existing customers, but TI does not recommend using this part in a new design.

PREVIEW: Device has been announced but is not in production. Samples may or may not be available.

OBSOLETE: TI has discontinued the production of the device.

(2) Eco Plan - The planned eco-friendly classification: Pb-Free (RoHS), Pb-Free (RoHS Exempt), or Green (RoHS & no Sb/Br) - please check <http://www.ti.com/productcontent> for the latest availability information and additional product content details.

TBD: The Pb-Free/Green conversion plan has not been defined.

Pb-Free (RoHS): TI's terms "Lead-Free" or "Pb-Free" mean semiconductor products that are compatible with the current RoHS requirements for all 6 substances, including the requirement that lead not exceed 0.1% by weight in homogeneous materials. Where designed to be soldered at high temperatures, TI Pb-Free products are suitable for use in specified lead-free processes.

Pb-Free (RoHS Exempt): This component has a RoHS exemption for either 1) lead-based flip-chip solder bumps used between the die and package, or 2) lead-based die adhesive used between the die and leadframe. The component is otherwise considered Pb-Free (RoHS compatible) as defined above.

Green (RoHS & no Sb/Br): TI defines "Green" to mean Pb-Free (RoHS compatible), and free of Bromine (Br) and Antimony (Sb) based flame retardants (Br or Sb do not exceed 0.1% by weight in homogeneous material)

(3) MSL, Peak Temp. - The Moisture Sensitivity Level rating according to the JEDEC industry standard classifications, and peak solder temperature.

(4) There may be additional marking, which relates to the logo, the lot trace code information, or the environmental category on the device.

(5) Multiple Device Markings will be inside parentheses. Only one Device Marking contained in parentheses and separated by a "~" will appear on a device. If a line is indented then it is a continuation of the previous line and the two combined represent the entire Device Marking for that device.

(6) Lead/Ball Finish - Orderable Devices may have multiple material finish options. Finish options are separated by a vertical ruled line. Lead/Ball Finish values may wrap to two lines if the finish value exceeds the maximum column width.

Important Information and Disclaimer: The information provided on this page represents TI's knowledge and belief as of the date that it is provided. TI bases its knowledge and belief on information provided by third parties, and makes no representation or warranty as to the accuracy of such information. Efforts are underway to better integrate information from third parties. TI has taken and continues to take reasonable steps to provide representative and accurate information but may not have conducted destructive testing or chemical analysis on incoming materials and chemicals. TI and TI suppliers consider certain information to be proprietary, and thus CAS numbers and other limited information may not be available for release.

In no event shall TI's liability arising out of such information exceed the total purchase price of the TI part(s) at issue in this document sold by TI to Customer on an annual basis.

TAPE AND REEL INFORMATION

QUADRANT ASSIGNMENTS FOR PIN 1 ORIENTATION IN TAPE

*All dimensions are nominal

Device	Package Type	Package Drawing	Pins	SPQ	Reel Diameter (mm)	Reel Width W1 (mm)	A0 (mm)	B0 (mm)	K0 (mm)	P1 (mm)	W (mm)	Pin1 Quadrant
BQ500110RGZR	VQFN	RGZ	48	2500	330.0	16.4	7.3	7.3	1.5	12.0	16.0	Q2
BQ500110RGZR	VQFN	RGZ	48	2500	330.0	16.4	7.3	7.3	1.1	12.0	16.0	Q2
BQ500110RGZT	VQFN	RGZ	48	250	180.0	16.4	7.3	7.3	1.5	12.0	16.0	Q2
BQ500110RGZT	VQFN	RGZ	48	250	180.0	16.4	7.3	7.3	1.1	12.0	16.0	Q2

TAPE AND REEL BOX DIMENSIONS

*All dimensions are nominal

Device	Package Type	Package Drawing	Pins	SPQ	Length (mm)	Width (mm)	Height (mm)
BQ500110RGZR	VQFN	RGZ	48	2500	367.0	367.0	38.0
BQ500110RGZR	VQFN	RGZ	48	2500	367.0	367.0	38.0
BQ500110RGZT	VQFN	RGZ	48	250	210.0	185.0	35.0
BQ500110RGZT	VQFN	RGZ	48	250	210.0	185.0	35.0

GENERIC PACKAGE VIEW

RGZ 48

VQFN - 1 mm max height

7 x 7, 0.5 mm pitch

PLASTIC QUADFLAT PACK- NO LEAD

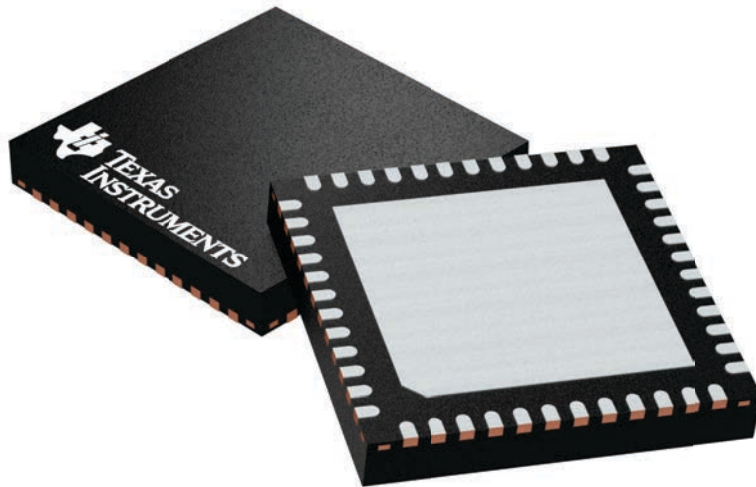

Images above are just a representation of the package family, actual package may vary.
Refer to the product data sheet for package details.

4224671/A

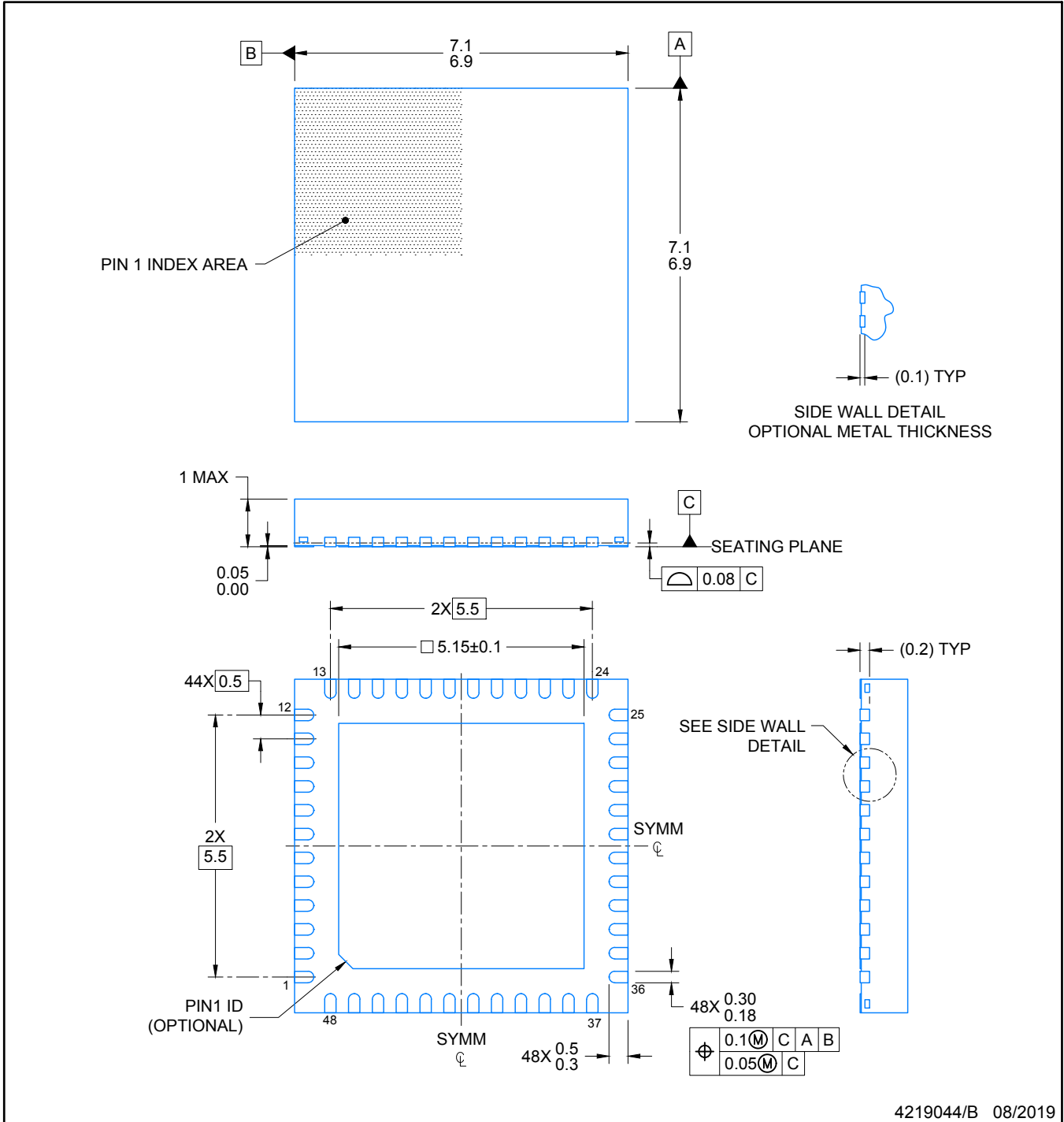

NOTES:

1. All linear dimensions are in millimeters. Any dimensions in parenthesis are for reference only. Dimensioning and tolerancing per ASME Y14.5M.
2. This drawing is subject to change without notice.
3. The package thermal pad must be soldered to the printed circuit board for optimal thermal and mechanical performance.

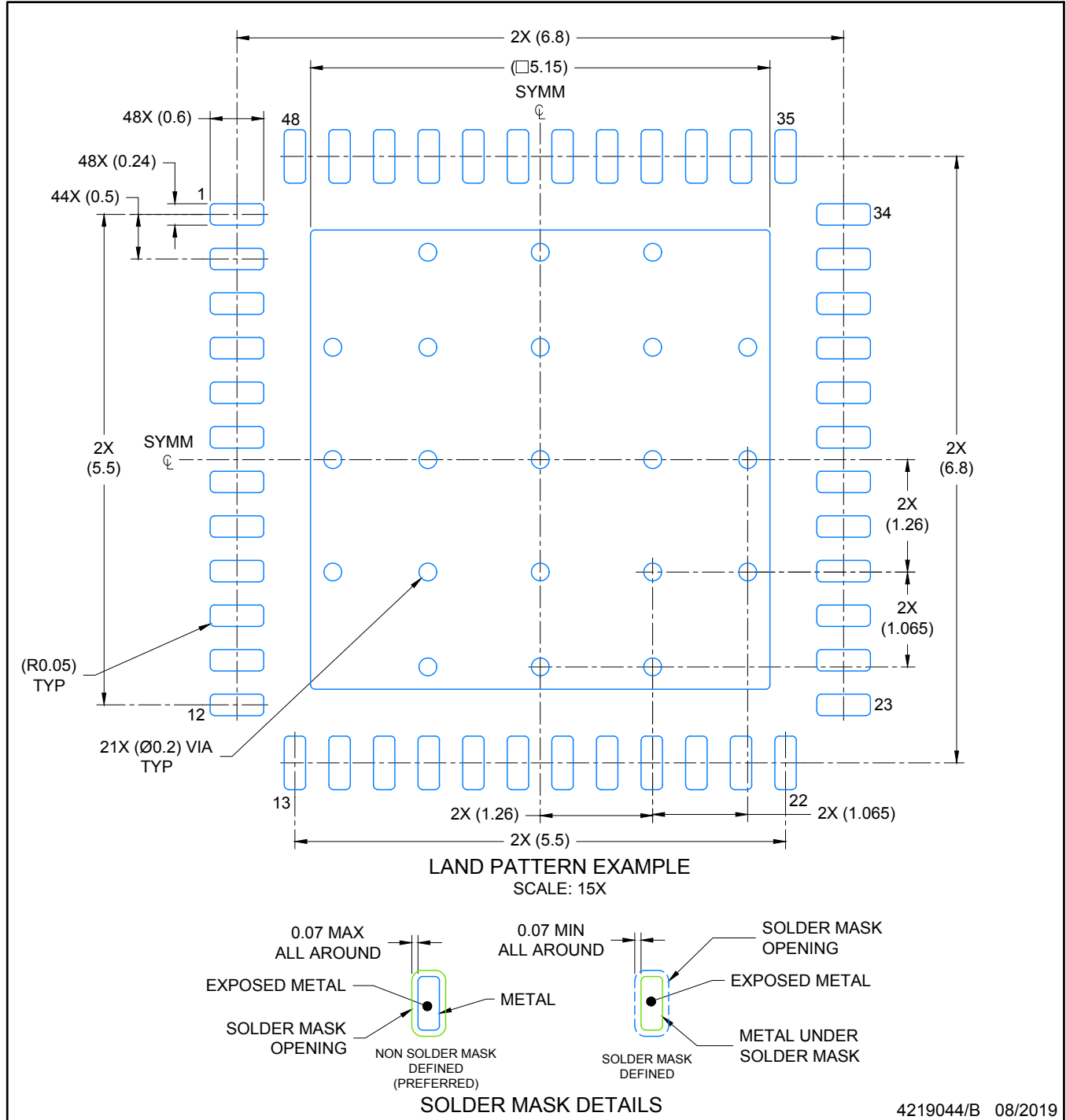

NOTES: (continued)

4. This package is designed to be soldered to a thermal pad on the board. For more information, see Texas Instruments literature number SLUA271 (www.ti.com/lit/slua271).
5. Vias are optional depending on application, refer to device data sheet. If any vias are implemented, refer to their locations shown on this view. It is recommended that vias under paste be filled, plugged or tented.

IMPORTANT NOTICE AND DISCLAIMER

TI PROVIDES TECHNICAL AND RELIABILITY DATA (INCLUDING DATASHEETS), DESIGN RESOURCES (INCLUDING REFERENCE DESIGNS), APPLICATION OR OTHER DESIGN ADVICE, WEB TOOLS, SAFETY INFORMATION, AND OTHER RESOURCES "AS IS" AND WITH ALL FAULTS, AND DISCLAIMS ALL WARRANTIES, EXPRESS AND IMPLIED, INCLUDING WITHOUT LIMITATION ANY IMPLIED WARRANTIES OF MERCHANTABILITY, FITNESS FOR A PARTICULAR PURPOSE OR NON-INFRINGEMENT OF THIRD PARTY INTELLECTUAL PROPERTY RIGHTS.

These resources are intended for skilled developers designing with TI products. You are solely responsible for (1) selecting the appropriate TI products for your application, (2) designing, validating and testing your application, and (3) ensuring your application meets applicable standards, and any other safety, security, or other requirements. These resources are subject to change without notice. TI grants you permission to use these resources only for development of an application that uses the TI products described in the resource. Other reproduction and display of these resources is prohibited. No license is granted to any other TI intellectual property right or to any third party intellectual property right. TI disclaims responsibility for, and you will fully indemnify TI and its representatives against, any claims, damages, costs, losses, and liabilities arising out of your use of these resources.

TI's products are provided subject to TI's Terms of Sale (www.ti.com/legal/termsofsale.html) or other applicable terms available either on ti.com or provided in conjunction with such TI products. TI's provision of these resources does not expand or otherwise alter TI's applicable warranties or warranty disclaimers for TI products.

Mailing Address: Texas Instruments, Post Office Box 655303, Dallas, Texas 75265
Copyright © 2019, Texas Instruments Incorporated

Looking for pricing, stock, or lifecycle information?

Click below to explore more details on WIN SOURCE:

 [View BQ500110RGZT on WIN SOURCE](#)

 [Texas Instruments](#) Information

Optimize Your Supply Chain with WIN SOURCE Solutions

-  Global Sourcing Solution
-  Obsolete Management
-  Cost Control Management
-  Shortage Management
-  Alternative Solution
-  Excess Inventory Management