



# THE DATASHEET OF SGSD100



## Complementary power Darlington transistors

### Features

- Complementary NPN - PNP transistors
- Monolithic Darlington configuration

### Applications

- Audio power amplifier
- DC-AC converter
- Easy driver for low voltage DC motor
- General purpose switching applications

### Description

The SGSD100 is an epitaxial-base NPN power transistor in monolithic Darlington configuration mounted in TO-247 plastic package. It is intended for use in general purpose and high current amplifier applications. The complementary PNP type is the SGSD200.

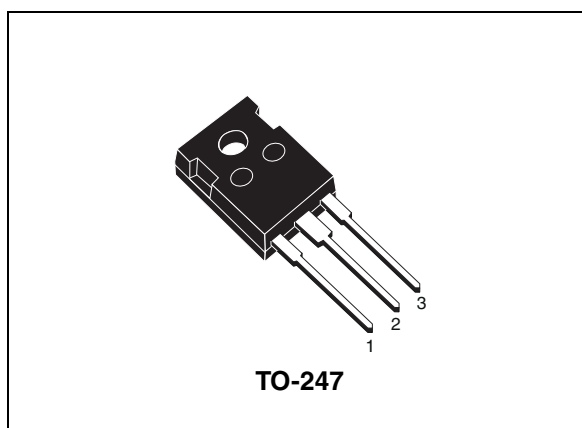

**Figure 1. Internal schematic diagrams**

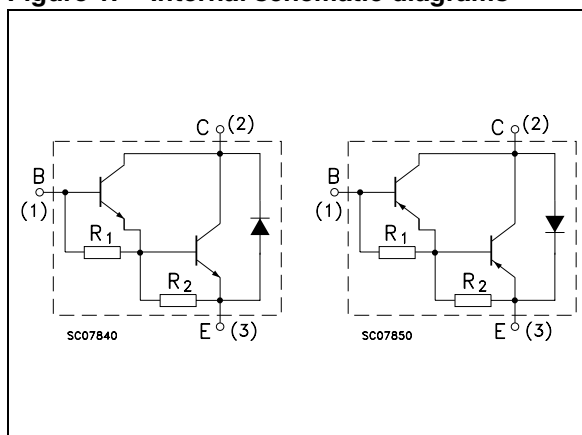

**Table 1. Device summary**

Order code	Marking	Package	Packaging
SGSD100	SGSD100	TO-247	Tube
SGSD200	SGSD200		

# 1 Absolute maximum rating

**Table 2. Absolute maximum rating**

Symbol	Parameter	Value		Unit
		NPN	SGSD100	
		PNP	SGSD200	
$V_{CBO}$	Collector-emitter voltage ( $I_E = 0$ )		80	V
$V_{CEO}$	Collector-emitter voltage ( $I_B = 0$ )		80	V
$I_C$	Collector current		25	A
$I_{CM}$	Collector peak current ( $t_p < 5\text{ms}$ )		40	A
$I_B$	Base current		6	A
$I_{BM}$	Base peak current ( $t_p < 5\text{ms}$ )		10	A
$P_{TOT}$	Total dissipation at $T_c \leq 25^\circ\text{C}$		130	W
$T_{stg}$	Storage temperature		-65 to 150	$^\circ\text{C}$
$T_J$	Max. operating junction temperature		150	$^\circ\text{C}$

Note: For PNP type voltage and current values are negative

**Table 3. Thermal data**

Symbol	Parameter	Value	Unit
$R_{thj-case}$	Thermal resistance junction-case max	0.96	$^\circ\text{C}/\text{W}$

## 2 Electrical characteristics

( $T_{case} = 25\text{ °C}$ ; unless otherwise specified)

**Table 4. Electrical characteristics**

Symbol	Parameter	Test conditions	Min.	Typ.	Max.	Unit
$I_{CBO}$	Collector cut-off current ( $I_E = 0$ )	$V_{CE} = 80\text{ V}$			0.5	mA
		$V_{CE} = 80\text{ V}$ $T_C = 100\text{ °C}$			1.5	mA
$I_{CEV}$	Collector cut-off current ( $V_{BE} = -0.3\text{V}$ )	$V_{CE} = 80\text{ V}$			0.1	mA
		$V_{CE} = 80\text{ V}$ $T_C = 100\text{ °C}$			2	mA
$I_{CEO}$	Collector cut-off current ( $I_B = 0$ )	$V_{CE} = 60\text{ V}$			0.5	mA
		$V_{CE} = 60\text{ V}$ $T_C = 100\text{ °C}$			1.5	mA
$I_{EBO}$	Emitter cut-off current ( $I_C = 0$ )	$V_{EB} = 5\text{ V}$			2	mA
$V_{CEO(sus)}^{(1)}$	Collector-emitter sustaining voltage ( $I_B = 0$ )	$I_C = 50\text{ mA}$	80			V
$V_{CE(sat)}^{(1)}$	Collector-emitter saturation voltage	$I_C = 5\text{ A}$ $I_B = 20\text{ mA}$		0.95	1.2	V
		$I_C = 5\text{ A}$ $I_B = 20\text{ mA}$ $T_C = 100\text{ °C}$		0.8		V
		$I_C = 10\text{ A}$ $I_B = 40\text{ mA}$		1.2	1.75	V
		$I_C = 10\text{ A}$ $I_B = 40\text{ mA}$ $T_C = 100\text{ °C}$		1.3		V
		$I_C = 20\text{ A}$ $I_B = 80\text{ mA}$		2	3.5	V
		$I_C = 20\text{ A}$ $I_B = 80\text{ mA}$ $T_C = 100\text{ °C}$		2.3		V
$V_{BE(sat)}^{(1)}$	Base-emitter saturation voltage	$I_C = 20\text{ A}$ $I_B = 80\text{ mA}$		2.6	3.3	V
		$I_C = 20\text{ A}$ $I_B = 80\text{ mA}$ $T_C = 100\text{ °C}$		2.5		V
$V_{BE}^{(1)}$	Base-emitter voltage	$I_C = 10\text{ A}$ $V_{CE} = 3\text{ V}$	1	1.8	3	V
		$I_C = 10\text{ A}$ $V_{CE} = 3\text{ V}$ $T_C = 100\text{ °C}$		1.6		V
$h_{FE}^{(1)}$	DC current gain	$I_C = 5\text{ A}$ $V_{CE} = 3\text{ V}$	600	5000	15000	
		$I_C = 5\text{ A}$ $V_{CE} = 3\text{ V}$ $T_C = 100\text{ °C}$		8000		
		$I_C = 10\text{ A}$ $V_{CE} = 3\text{ V}$	500	4000	12000	
		$I_C = 10\text{ A}$ $V_{CE} = 3\text{ V}$ $T_C = 100\text{ °C}$		8000		
		$I_C = 20\text{ A}$ $V_{CE} = 3\text{ V}$	300	2000	6000	
		$I_C = 20\text{ A}$ $V_{CE} = 3\text{ V}$ $T_C = 100\text{ °C}$		2000		
$V_F^{(1)}$	Diode forward voltage	$I_F = 5\text{ A}$		1.2		V
		$I_F = 5\text{ A}$ $T_C = 100\text{ °C}$		0.85		V
		$I_F = 10\text{ A}$		1.6		V
		$I_F = 10\text{ A}$ $T_C = 100\text{ °C}$		1.4		V
		$I_F = 20\text{ A}$		2.3		V
		$I_F = 20\text{ A}$ $T_C = 100\text{ °C}$		1.3		V

Symbol	Parameter	Test conditions	Min.	Typ.	Max.	Unit
$E_{s/b}$	Second breakdown energy	$V_{CC} = 30\text{ V}$ $L = 3\text{ mH}$	250			mJ
		$V_{CC} = 30\text{ V}$ $L = 3\text{ mH}$ $T_C = 100\text{ }^\circ\text{C}$	250			mJ
$I_{s/b}$	Second breakdown current	$V_{CE} = 25\text{ V}$ $t = 500\text{ ms}$	6			A

1. Pulsed : Pulse duration = 300  $\mu\text{s}$ , duty cycle  $\leq 1.5\%$

Note: For PNP type voltage and current values are negative

## 2.1 Electrical characteristics (curves)

Figure 2. Safe operating area

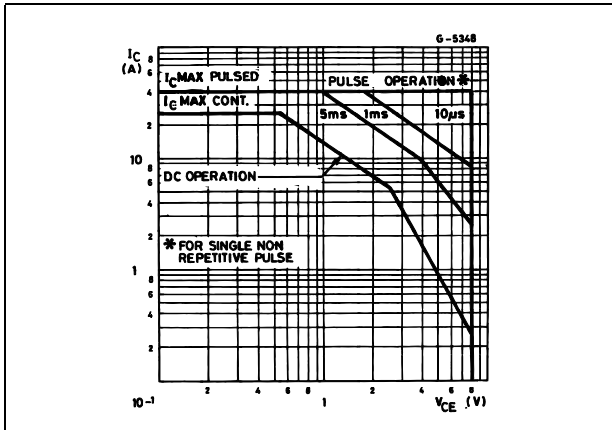

Figure 3. DC current gain (NPN type)

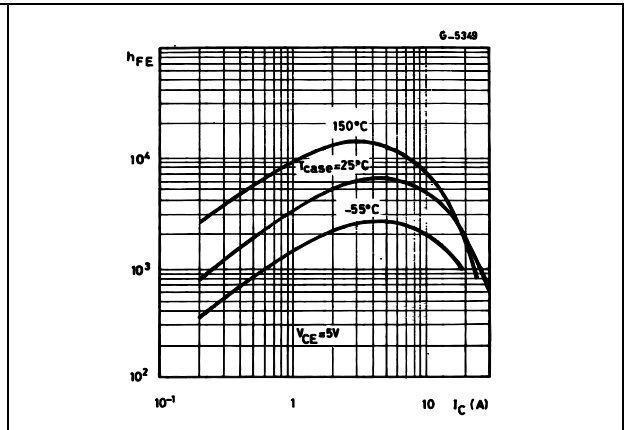

Figure 4. DC current gain (PNP type)

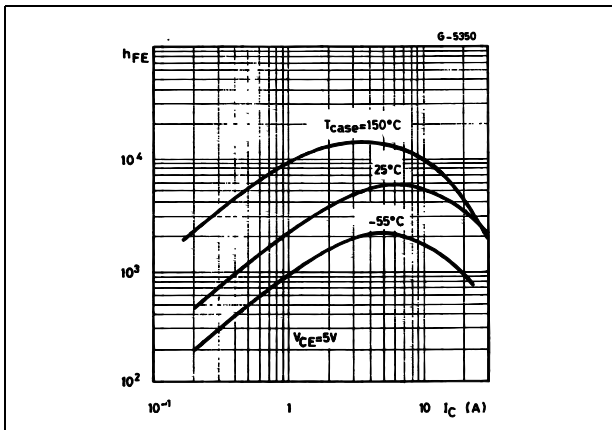

Figure 5. DC current gain (NPN type)

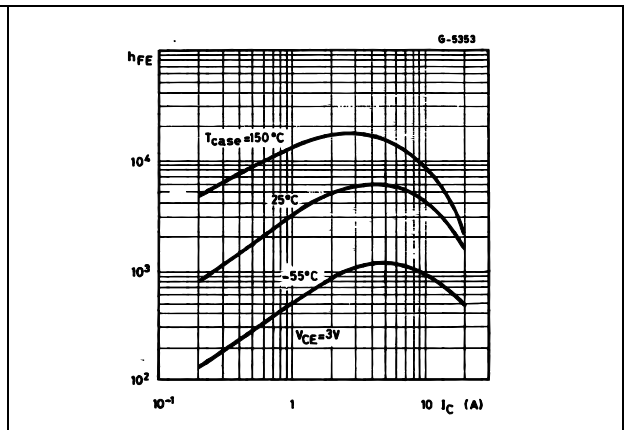

Figure 6. DC current gain (PNP type)

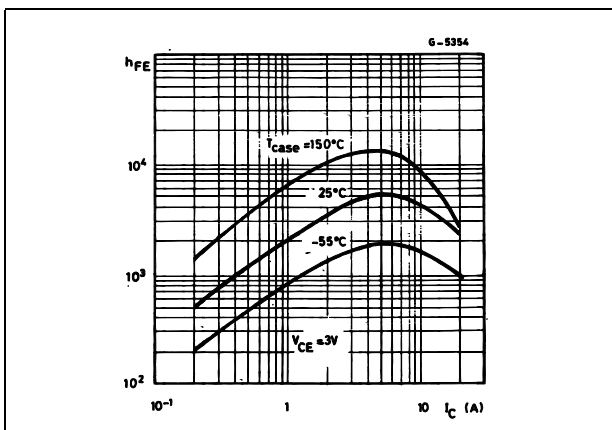
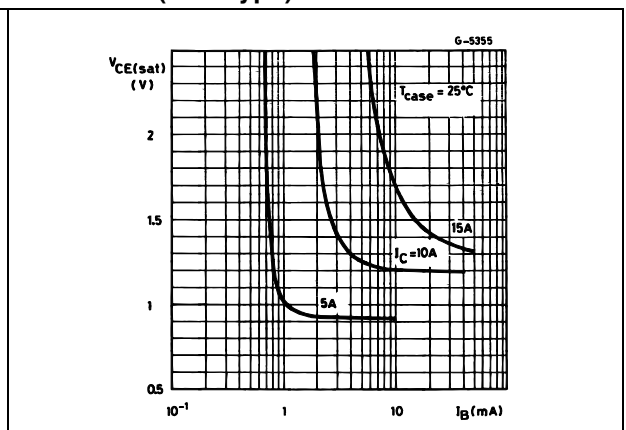
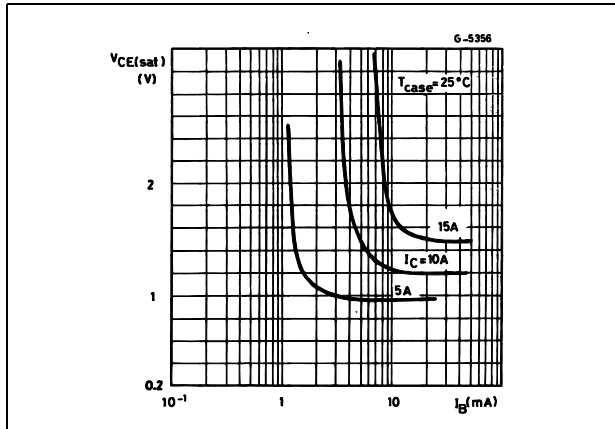

Figure 7. Collector-emitter saturation voltage (NPN type)



**Figure 8. Base-emitter saturation voltage (PNP type)**



### 3 Package mechanical data

In order to meet environmental requirements, ST offers these devices in ECOPACK® packages. These packages have a Lead-free second level interconnect . The category of second level interconnect is marked on the package and on the inner box label, in compliance with JEDEC Standard JESD97. The maximum ratings related to soldering conditions are also marked on the inner box label. ECOPACK is an ST trademark. ECOPACK specifications are available at: [www.st.com](http://www.st.com)

**TO-247 Mechanical data**

Dim.	mm.		
	Min.	Typ	Max.
A	4.85		5.15
A1	2.20		2.60
b	1.0		1.40
b1	2.0		2.40
b2	3.0		3.40
c	0.40		0.80
D	19.85		20.15
E	15.45		15.75
e		5.45	
L	14.20		14.80
L1	3.70		4.30
L2		18.50	
øP	3.55		3.65
øR	4.50		5.50
S		5.50	

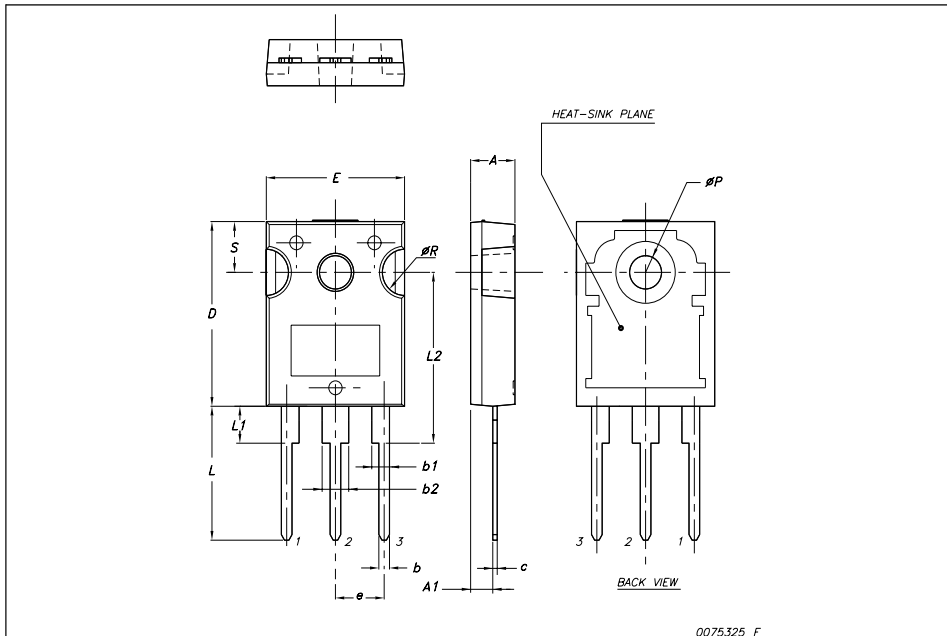

## 4 Revision history

**Table 5. Document revision history**

Date	Revision	Changes
11-Oct-2003	3	
24-Jan-2007	4	Package change from TO-218 to TO-247.

**Please Read Carefully:**

Information in this document is provided solely in connection with ST products. STMicroelectronics NV and its subsidiaries ("ST") reserve the right to make changes, corrections, modifications or improvements, to this document, and the products and services described herein at any time, without notice.

All ST products are sold pursuant to ST's terms and conditions of sale.

Purchasers are solely responsible for the choice, selection and use of the ST products and services described herein, and ST assumes no liability whatsoever relating to the choice, selection or use of the ST products and services described herein.

No license, express or implied, by estoppel or otherwise, to any intellectual property rights is granted under this document. If any part of this document refers to any third party products or services it shall not be deemed a license grant by ST for the use of such third party products or services, or any intellectual property contained therein or considered as a warranty covering the use in any manner whatsoever of such third party products or services or any intellectual property contained therein.

**UNLESS OTHERWISE SET FORTH IN ST'S TERMS AND CONDITIONS OF SALE ST DISCLAIMS ANY EXPRESS OR IMPLIED WARRANTY WITH RESPECT TO THE USE AND/OR SALE OF ST PRODUCTS INCLUDING WITHOUT LIMITATION IMPLIED WARRANTIES OF MERCHANTABILITY, FITNESS FOR A PARTICULAR PURPOSE (AND THEIR EQUIVALENTS UNDER THE LAWS OF ANY JURISDICTION), OR INFRINGEMENT OF ANY PATENT, COPYRIGHT OR OTHER INTELLECTUAL PROPERTY RIGHT.**

**UNLESS EXPRESSLY APPROVED IN WRITING BY AN AUTHORIZED REPRESENTATIVE OF ST, ST PRODUCTS ARE NOT RECOMMENDED, AUTHORIZED OR WARRANTED FOR USE IN MILITARY, AIR CRAFT, SPACE, LIFE SAVING, OR LIFE SUSTAINING APPLICATIONS, NOR IN PRODUCTS OR SYSTEMS, WHERE FAILURE OR MALFUNCTION MAY RESULT IN PERSONAL INJURY, DEATH, OR SEVERE PROPERTY OR ENVIRONMENTAL DAMAGE. ST PRODUCTS WHICH ARE NOT SPECIFIED AS "AUTOMOTIVE GRADE" MAY ONLY BE USED IN AUTOMOTIVE APPLICATIONS AT USER'S OWN RISK.**

Resale of ST products with provisions different from the statements and/or technical features set forth in this document shall immediately void any warranty granted by ST for the ST product or service described herein and shall not create or extend in any manner whatsoever, any liability of ST.

ST and the ST logo are trademarks or registered trademarks of ST in various countries.

Information in this document supersedes and replaces all information previously supplied.

The ST logo is a registered trademark of STMicroelectronics. All other names are the property of their respective owners.

© 2008 STMicroelectronics - All rights reserved



STMicroelectronics group of companies

Australia - Belgium - Brazil - Canada - China - Czech Republic - Finland - France - Germany - Hong Kong - India - Israel - Italy - Japan - Malaysia - Malta - Morocco - Singapore - Spain - Sweden - Switzerland - United Kingdom - United States of America

[www.st.com](http://www.st.com)

## Looking for pricing, stock, or lifecycle information?

Click below to explore more details on WIN SOURCE:

-  [View SGSD100 on WIN SOURCE](#)
-  [STMicroelectronics](#) Information

## Optimize Your Supply Chain with WIN SOURCE Solutions

-  Global Sourcing Solution
-  Obsolete Management
-  Cost Control Management
-  Shortage Management
-  Alternative Solution
-  Excess Inventory Management