



**THE DATASHEET OF
TL7705BID**



TL7702B, TL7733B, and TL7705B Supply-Voltage Supervisors

1 Features

- Power-On Reset Generator
- Automatic Reset Generation After Voltage Drop
- RESET Output Defined From $V_{CC} \geq 1\text{ V}$
- Precision Voltage Sensor
- Temperature-Compensated Voltage Reference
- True and Complement Reset Outputs
- Externally Adjustable Pulse Duration

2 Applications

- Digital Signal Processors (DSPs)
- Microcontrollers (MCUs)
- FPGAs, ASICs
- Notebooks and Desktop computers
- Set-Top Boxes
- Industrial Control Systems

3 Description

The TL7702B, TL7705B, and TL7733B are integrated-circuit supply-voltage supervisors designed for use as reset controllers in microcomputer and microprocessor systems. The supply-voltage supervisor monitors the supply for undervoltage conditions at the SENSE input. When an undervoltage condition occurs during normal operation, outputs RESET and RESET go active.

The TL7702BC, TL7705BC, and TL7733BC are characterized for operation from 0°C to 70°C . The TL7702BI, TL7705BI, and TL7733BI are characterized for operation from -40°C to 85°C . The TL7705BQ is characterized for operation from -40°C to 125°C .

Device Information⁽¹⁾

PART NUMBER	PACKAGE	BODY SIZE (NOM)
TL77xxBD	SOIC (8)	4.90 mm x 3.91 mm
TL77xxBP	PDIP (8)	9.81 mm x 6.35 mm

(1) For all available packages, see the orderable addendum at the end of the data sheet.

Functional Block Diagram

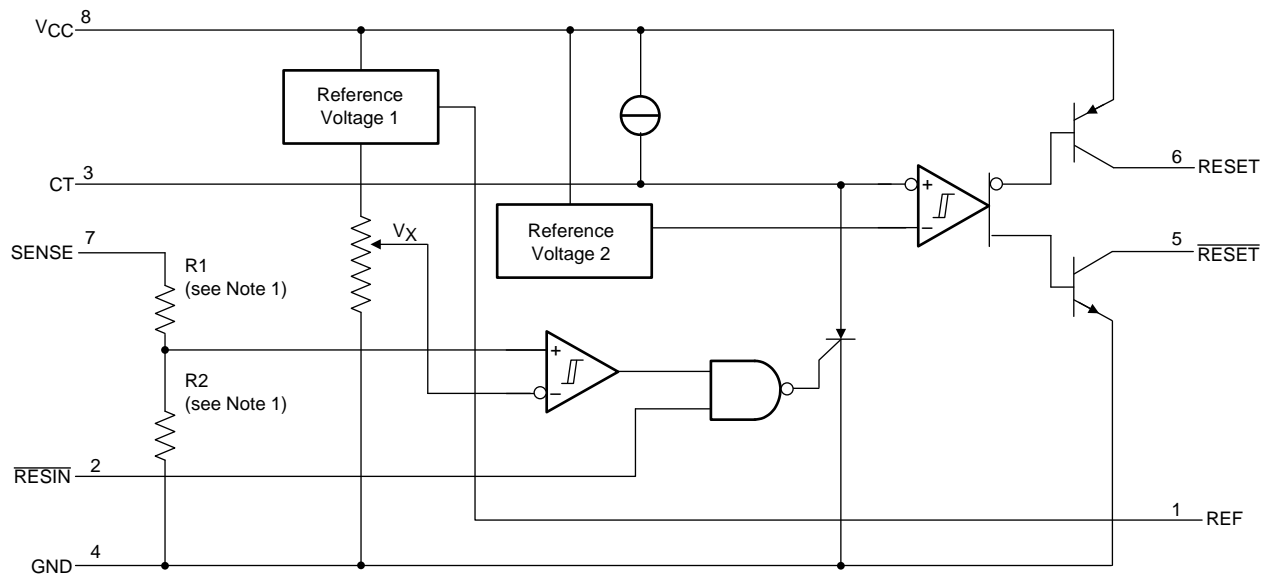

Copyright © 2016, Texas Instruments Incorporated



Table of Contents

1 Features	1	8.3 Feature Description	10
2 Applications	1	8.4 Device Functional Modes	10
3 Description	1	9 Application and Implementation	11
4 Revision History	2	9.1 Application Information	11
5 Pin Configuration and Functions	3	9.2 Typical Application	11
6 Specifications	4	10 Power Supply Recommendations	13
6.1 Absolute Maximum Ratings	4	11 Layout	14
6.2 ESD Ratings	4	11.1 Layout Guidelines	14
6.3 Recommended Operating Conditions	4	11.2 Layout Example	14
6.4 Thermal Information	4	12 Device and Documentation Support	15
6.5 Electrical Characteristics: TL77xxBC, TL77xxBI, and TL7705BQ	5	12.1 Related Links	15
6.6 Switching Characteristics: TL77xxBC, TL77xxBI, and TL7705BQ	5	12.2 Receiving Notification of Documentation Updates	15
6.7 Typical Characteristics	7	12.3 Community Resources	15
7 Parameter Measurement Information	7	12.4 Trademarks	15
8 Detailed Description	9	12.5 Electrostatic Discharge Caution	15
8.1 Overview	9	12.6 Glossary	15
8.2 Functional Block Diagram	9	13 Mechanical, Packaging, and Orderable Information	15

4 Revision History

Changes from Revision M (May 2003) to Revision N

Page

• Added <i>ESD Ratings</i> table, <i>Feature Description</i> section, <i>Device Functional Modes</i> , <i>Application and Implementation</i> section, <i>Power Supply Recommendations</i> section, <i>Layout</i> section, <i>Device and Documentation Support</i> section, and <i>Mechanical, Packaging, and Orderable Information</i> section.	1
• Deleted <i>Ordering Information</i> table; see POA at the end of the data sheet	1
• Deleted Lead temperature row	4
• Changed $R_{\theta JA}$ for D (SOIC) from 97 to 109.2 and for P (PDIP) from 85 to 51.4	4

5 Pin Configuration and Functions

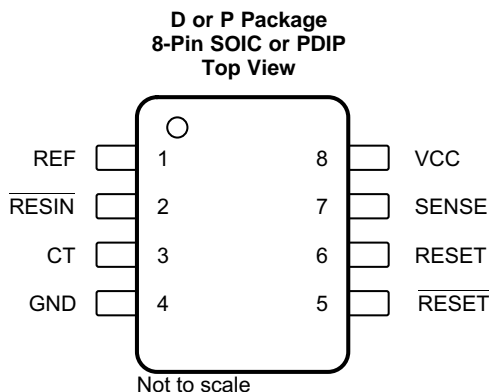

Pin Functions

PIN		I/O	DESCRIPTION
NAME	NO.		
CT	3	O	Timing capacitor input. The timing capacitor determines the time delay that the reset outputs remain active after the voltage at the SENSE input exceeds the positive-going threshold value.
GND	4	—	Ground
REF	1	O	Reference voltage. See Electrical Characteristics: TL77xxBC, TL77xxBI, and TL7705BQ for reference voltage output and specification.
RESET	6	O	Active high reset. See Figure 1 for RESET function and timing.
$\overline{\text{RESET}}$	5	O	Active low reset. See Figure 1 for $\overline{\text{RESET}}$ function and timing.
$\overline{\text{RESIN}}$	2	I	Reset input. When the Reset Input is low, the RESET output goes low and the $\overline{\text{RESET}}$ goes high. When the Reset Input is high, the RESET and $\overline{\text{RESET}}$ outputs are allowed to trigger based on the SENSE voltage.
SENSE	7	I	Sense input. Voltage input to be supervised. See Figure 1 for SENSE function and timing.
VCC	8	—	Supply voltage. See Recommended Operating Conditions for recommended voltage input range.

6 Specifications

6.1 Absolute Maximum Ratings

 over operating free-air temperature range (unless otherwise noted)⁽¹⁾

		MIN	MAX	UNIT
Supply voltage ⁽²⁾ , V_{CC}			20	V
Input voltage, V_I	$\overline{\text{RESIN}}$	-0.3	20	V
	SENSE	-0.3	20	
High-level output current, I_{OH} (RESET)			-30	mA
Low-level output current, I_{OL} ($\overline{\text{RESET}}$)			30	mA
Operating virtual junction temperature, T_J			150	°C
Storage temperature, T_{stg}		-65	150	°C

- (1) Stresses beyond those listed under *Absolute Maximum Ratings* may cause permanent damage to the device. These are stress ratings only, which do not imply functional operation of the device at these or any other conditions beyond those indicated under *Recommended Operating Conditions*. Exposure to absolute-maximum-rated conditions for extended periods may affect device reliability.
- (2) All voltage values are with respect to the network ground terminal.

6.2 ESD Ratings

		VALUE	UNIT
$V_{(ESD)}$ Electrostatic discharge	Human-body model (HBM), per ANSI/ESDA/JEDEC JS-001 ⁽¹⁾	2000	V
	Charged-device model (CDM), per JEDEC specification JESD22-C101 ⁽²⁾	1000	

- (1) JEDEC document JEP155 states that 500-V HBM allows safe manufacturing with a standard ESD control process.
- (2) JEDEC document JEP157 states that 250-V CDM allows safe manufacturing with a standard ESD control process.

6.3 Recommended Operating Conditions

over operating free-air temperature range (unless otherwise noted)

		MIN	MAX	UNIT
V_{CC} Supply voltage		3.6	18	V
V_{IH} High-level input voltage	$\overline{\text{RESIN}}$	2	18	V
V_{IL} Low-level input voltage	$\overline{\text{RESIN}}$	0	0.8	V
V_I Input voltage	SENSE	0	18	V
I_{OH} High-level output current	RESET		-20	mA
I_{OL} Low-level output current	$\overline{\text{RESET}}$		20	mA
T_A Operating free-air temperature	TL77xxBC	0	70	°C
	TL77xxBI	-40	85	
	TL7705BQ	-40	125	

6.4 Thermal Information

THERMAL METRIC ⁽¹⁾⁽²⁾		TL77xxB		UNIT
		D (SOIC)	P (PDIP)	
		8 PINS	8 PINS	
$R_{\theta JA}$ Junction-to-ambient thermal resistance	109.2	51.4	°C/W	
$R_{\theta JC(top)}$ Junction-to-case (top) thermal resistance	56	40.6	°C/W	
$R_{\theta JB}$ Junction-to-board thermal resistance	49.9	28.6	°C/W	
Ψ_{JT} Junction-to-top characterization parameter	11.4	17.7	°C/W	
Ψ_{JB} Junction-to-board characterization parameter	49.4	28.5	°C/W	

- (1) For more information about traditional and new thermal metrics, see the *Semiconductor and IC Package Thermal Metrics* application report.
- (2) Maximum power dissipation is a function of $T_{J(max)}$, $R_{\theta JA}$, and T_A . The maximum allowable power dissipation at any allowable ambient temperature is $P_D = (T_{J(max)} - T_A) / R_{\theta JA}$. Operating at the absolute maximum T_J of 150°C can affect reliability.

6.5 Electrical Characteristics: TL77xxBC, TL77xxBI, and TL7705BQ

over operating free-air temperature range (unless otherwise noted)⁽¹⁾

PARAMETER		TEST CONDITIONS	MIN	TYP	MAX	UNIT	
V _{OH}	High-level output voltage, RESET	I _{OH} = –16 mA	V _{CC} – 1.5			V	
V _{OL}	Low-level output voltage, RESET	I _{OL} = 16 mA	0.4			V	
V _{REF}	Reference voltage, REF	I _{ref} = –500 μA, T _A = 25°C	2.48	2.53	2.58	V	
V _{IT-}	Negative-going input threshold voltage at SENSE input	TL7702B	T _A = 25°C	2.505	2.53	2.555	V
		TL7705B		4.5	4.55	4.6	
		TL7733B		3.03	3.08	3.13	
		TL7702B	T _A = full range ⁽²⁾	2.48	2.53	2.58	
		TL7705B		4.45	4.55	4.65	
		TL7733B		3	3.08	3.16	
V _{HYS}	Hysteresis, SENSE (V _{IT+} – V _{IT-})	V _{CC} = 3.6 V to 18 V, T _A = 25°C	10		mV		
			30				
			10				
V _{RES}	Power-up reset voltage ⁽³⁾	I _{OL} at RESET = 2 mA, T _A = 25°C	1			V	
I _I	Input current	RESIN	V _I = 0.4 V to V _{CC}			–10	μA
		SENSE, TL7702B	V _I = V _{REF} to 18 V			–0.1	
I _{OH}	High-level output current, RESET	V _O = 18 V, see Figure 8	50			μA	
I _{OL}	Low-level output current, RESET	V _O = 0 V, see Figure 7	–50			μA	
I _{CC}	Supply current	V _{SENSE} = 15 V, RESIN ≥ 2 V	1.8		3	μA	
		V _{CC} = 18 V, T _A = full range ⁽²⁾	3.5				

(1) All electrical characteristics are measured with 0.1-μF capacitors connected at REF, CT, and VCC to GND.

(2) Full range is 0°C to 70°C for the C-suffix devices, –40°C to 85°C for the I-suffix devices, and –40°C to 125°C for the Q-suffix device.

(3) This is the lowest voltage at which RESET becomes active.

6.6 Switching Characteristics: TL77xxBC, TL77xxBI, and TL7705BQ

V_{CC} = 5 V, C_T open, T_A = 25°C, over operating free-air temperature range (unless otherwise noted)

PARAMETER	FROM (INPUT)	TO (OUTPUT)	TEST CONDITIONS	MIN	TYP	MAX	UNIT
t _{PLH}	RESIN	RESET	See Figure 1, Figure 2, Figure 7	270	500		ns
t _{PHL}	RESIN	RESET	See Figure 1, Figure 2, Figure 8	270	500		ns
t _w	RESIN		See Figure 9, Figure 10	150			ns
	SENSE			100			
t _r		RESET	See Figure 7, Figure 8, Figure 1	75			ns
		RESET		75			
t _f		RESET	See Figure 7, Figure 8, Figure 1	150		200	ns
		RESET		50			

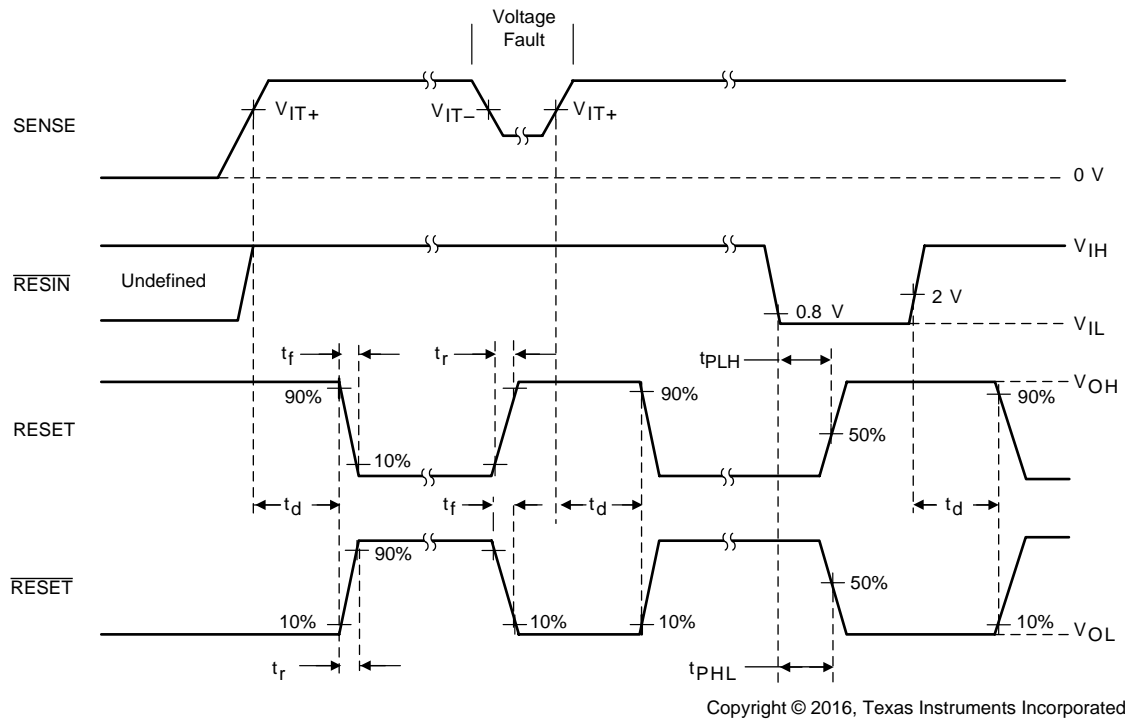
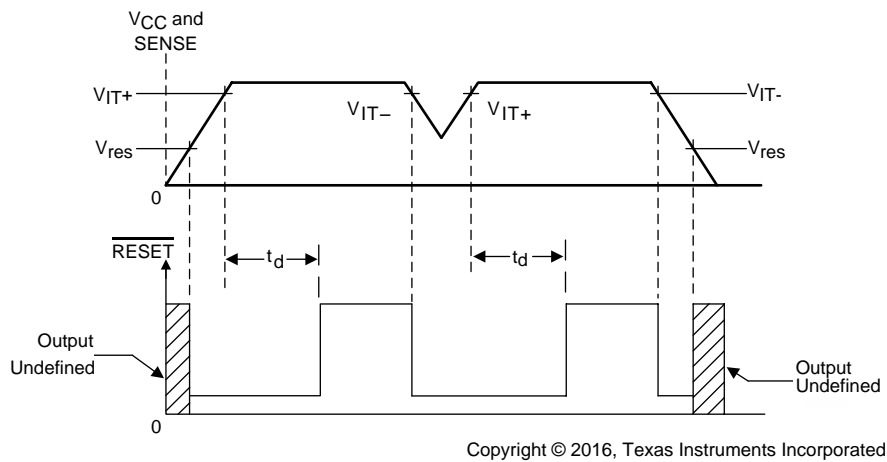
Figure 1. Timing Diagram

Figure 2. V_{IT} and V_{RES} Timing Diagram

6.7 Typical Characteristics

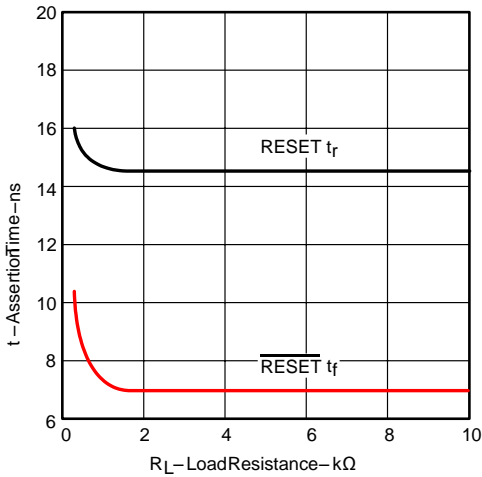

Figure 3. Assertion Time vs Load Resistance

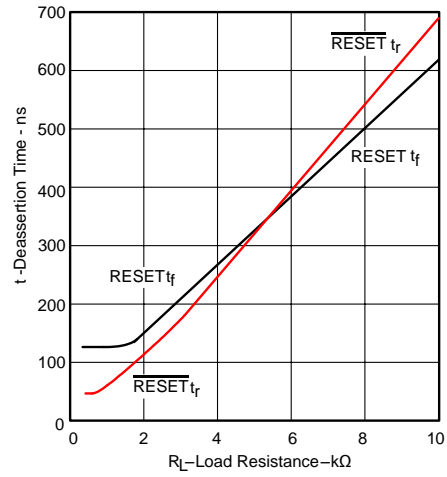

Figure 4. Deassertion Time vs Load Resistance

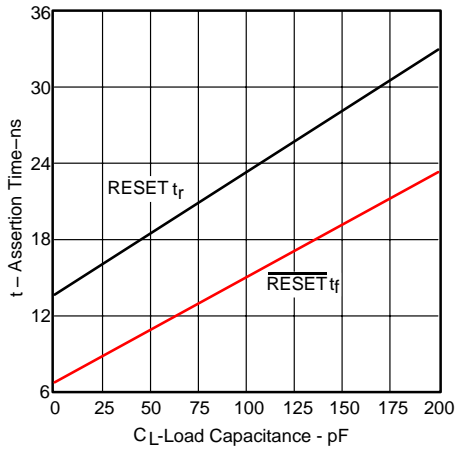

Figure 5. Assertion Time vs Load Capacitance

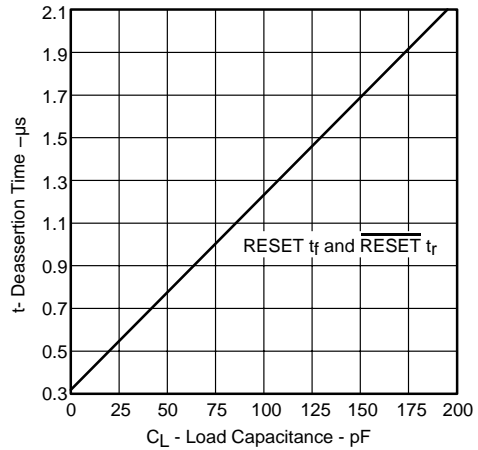
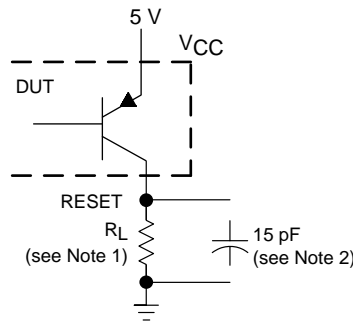

Figure 6. Deassertion Time vs Load Capacitance

7 Parameter Measurement Information



RESET OUTPUT CONFIGURATION

Copyright © 2016, Texas Instruments Incorporated

- (1) For I_{OL} and I_{OH} , $R_L = 10\text{ k}\Omega$. For all switching characteristics, $R_L = 511\ \Omega$.
- (2) This figure includes jig and probe capacitance.

Figure 7. RESET Output Configuration

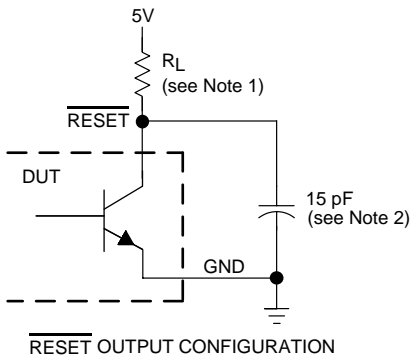
Parameter Measurement Information (continued)

Copyright © 2016, Texas Instruments Incorporated

- (1) For I_{OL} and I_{OH} , $R_L = 10\text{ k}\Omega$. For all switching characteristics, $R_L = 511\ \Omega$.
- (2) This figure includes jig and probe capacitance.

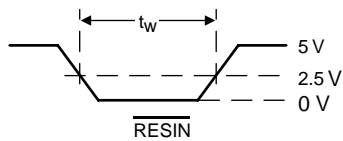
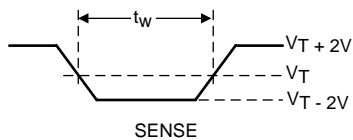
Figure 8. RESET Output Configuration

Figure 9. Input Pulse Definition RESIN

Figure 10. Input Pulse Definition SENSE

8 Detailed Description

8.1 Overview

The TL7702B, TL7705B, and TL7733B are integrated-circuit supply-voltage supervisors designed for use as reset controllers in microcomputer and microprocessor systems. The supply-voltage supervisor monitors the supply for undervoltage conditions at the SENSE input. During power up, the $\overline{\text{RESET}}$ output becomes active (low) when V_{CC} attains a value approaching 1 V. As V_{CC} approaches 3 V (assuming that SENSE is above $V_{\text{T}+}$), the delay-timer function activates a time delay, after which outputs $\overline{\text{RESET}}$ and RESET go inactive (high and low, respectively). When an undervoltage condition occurs during normal operation, outputs $\overline{\text{RESET}}$ and RESET go active. To ensure that a complete reset occurs, the reset outputs remain active for a time delay after the voltage at the SENSE input exceeds the positive-going threshold value. The time delay is determined by the value of the external capacitor C_{T} : $t_{\text{d}} \approx 2.6 \times 10^4 \times C_{\text{T}}$, where C_{T} is in farads (F) and t_{d} is in seconds (s).

An external capacitor (typically 0.1 μF) must be connected to REF to reduce the influence of fast transients in the supply voltage.

8.2 Functional Block Diagram

The functional block diagram is shown for illustrative purposes only; the actual circuit includes a trimming network to adjust the reference voltage and sense-comparator trip point.

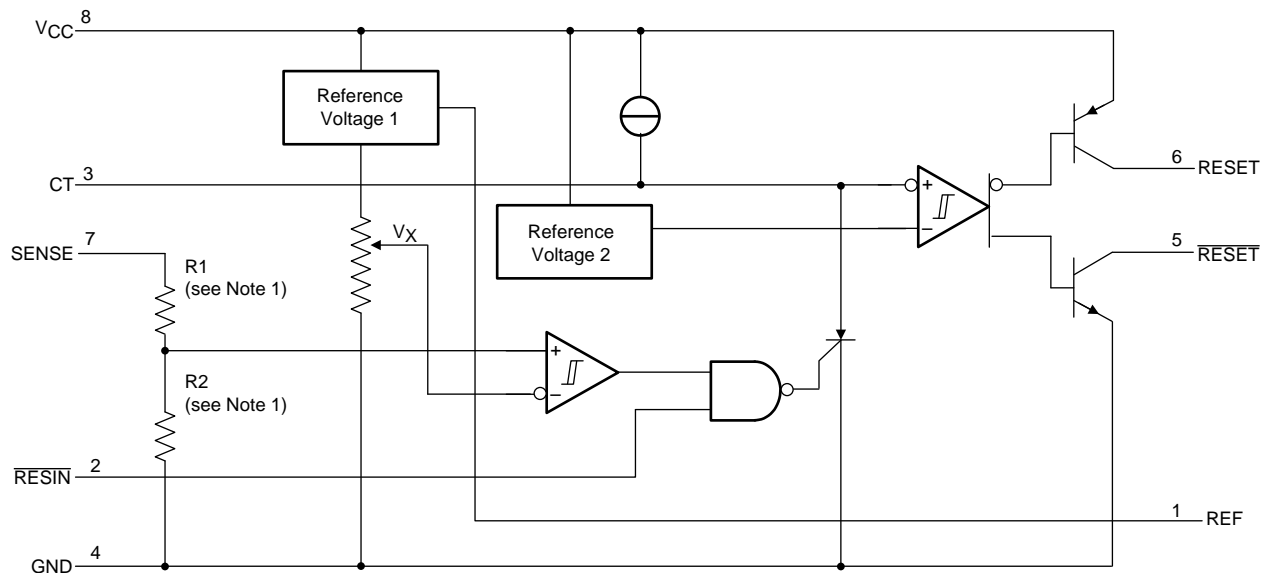

Copyright © 2016, Texas Instruments Incorporated

8.3 Feature Description

8.3.1 Wide Supply-Voltage Range

The TL77xxB family operates using a wide supply voltage from 3.6 V to 18 V.

8.3.2 Adjustable Pulse Duration

The CT pin enables the ability to set a user-defined time delay in order to ensure that the fault condition is recognized. The external capacitor charges based on an internal current source until the voltage at the CT pin exceeds that of the internal reference voltage.

The time delay is determined by the value of the external capacitor C_T : $t_d \approx 2.6 \times 10^4 \times C_T$, where C_T is in farads (F) and t_d is in seconds (s).

The current source to charge the timing capacitor varies $\pm 15\%$. Reference Voltage 2 is approximately 1.8 V and varies approximately $\pm 5\%$. Once the timing capacitor charges, it discharges to about 0.6 V, not completely to 0 V.

8.4 Device Functional Modes

Figure 11 displays how the RESET and $\overline{\text{RESET}}$ output pins respond to the change in the the SENSE and $\overline{\text{RESIN}}$ input pins. When the $\overline{\text{RESIN}}$ pin is high, the RESET outputs are able to respond to a drop in the supply voltage at the SENSE pin. When the RESIN pin is low, the RESET and $\overline{\text{RESET}}$ pins are set HIGH and LOW respectively.

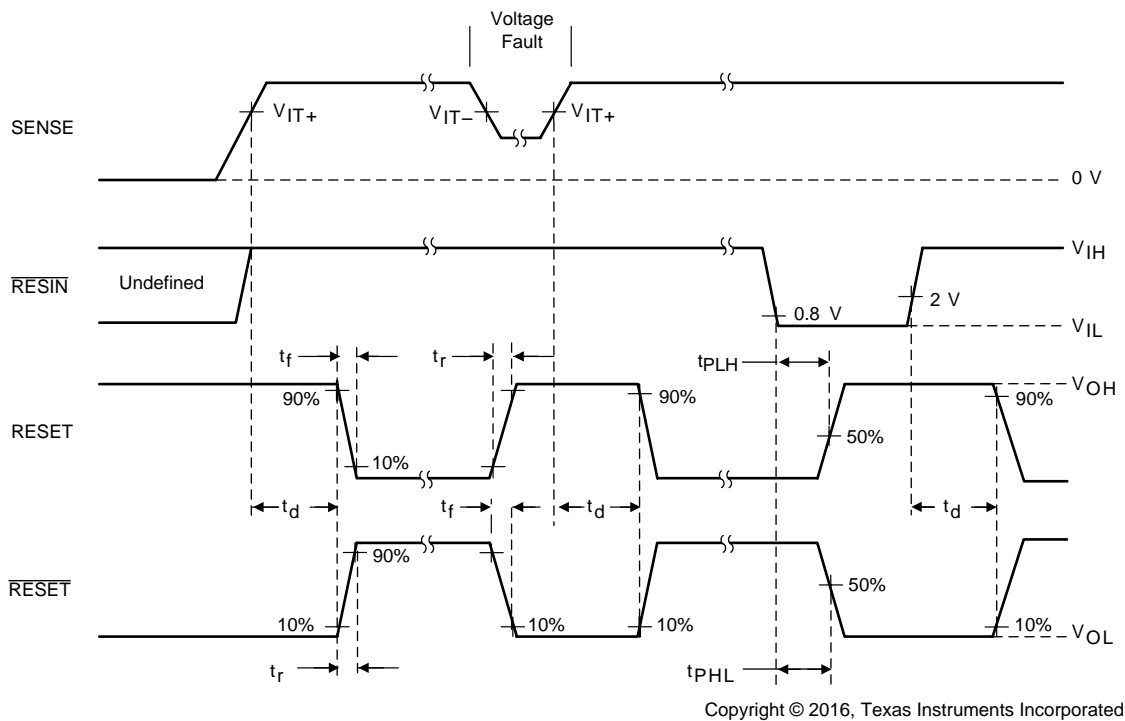

Figure 11. TL77xxB RESET and $\overline{\text{RESET}}$ Response and Timing

9 Application and Implementation

NOTE

Information in the following applications sections is not part of the TI component specification, and TI does not warrant its accuracy or completeness. TI's customers are responsible for determining suitability of components for their purposes. Customers should validate and test their design implementation to confirm system functionality.

9.1 Application Information

Figure 12 shows an application where the TL7705B device is being used to sense the voltage supply for a microcontroller that is supplied with 5 V. If the voltage supply drops below the threshold voltage, the $\overline{\text{RESET}}$ pin is pulled LOW, signaling the microcontroller to reset.

9.2 Typical Application

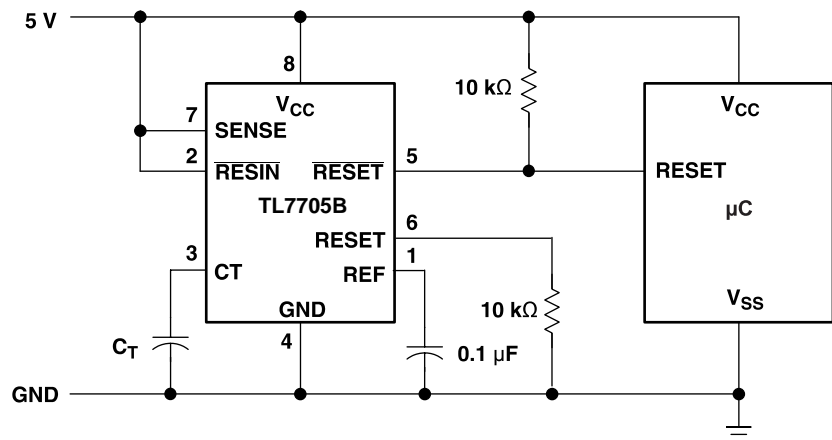

Copyright © 2016, Texas Instruments Incorporated

Figure 12. Reset Controller Schematic for a Microprocessor

9.2.1 Design Requirements

The external components required include the decoupling capacitor for the REF pin and the timing capacitor for the CT pin. Additionally, because the $\overline{\text{RESET}}$ output is open collector, a pullup resistor is required to ensure the correct HIGH level for the microcontroller RESET pin.

9.2.2 Detailed Design Procedure

TI recommends pullup and pulldown resistors of 10 kΩ.

To achieve a 2.6 ms time delay, use $C_T = 0.1 \mu\text{F}$.

Both outputs of the TL770xB must be terminated with similar value resistors, even when only one is being used. This prevents unwanted plateauing in either output waveform during switching, which may be interpreted as an undefined state or delay system reset

Typical Application (continued)

9.2.3 Application Curve

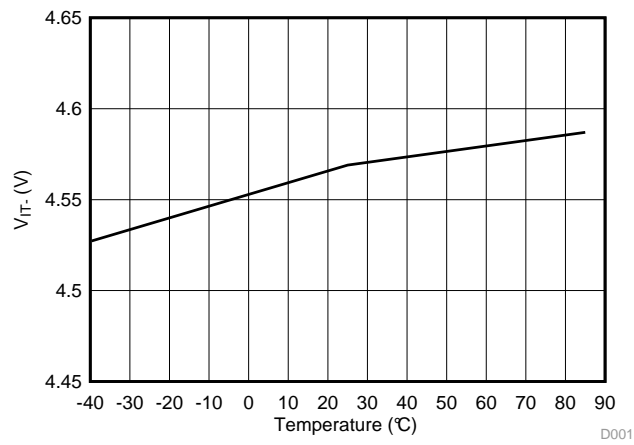
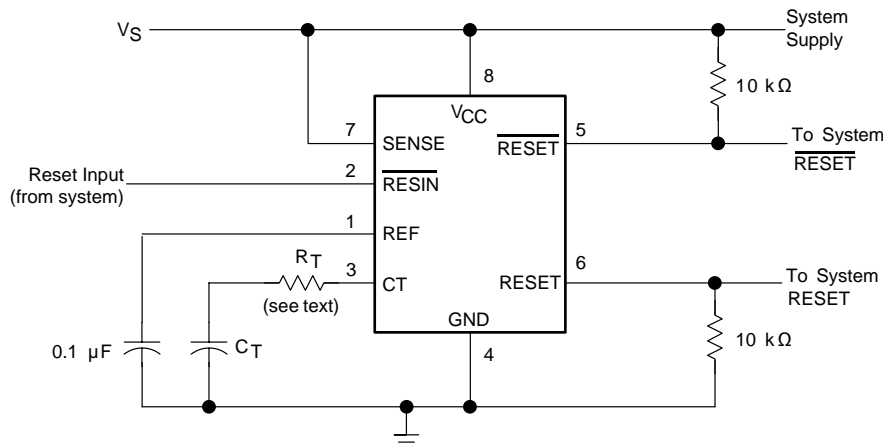

Figure 13. TL7705B Threshold Voltage vs Temperature

10 Power Supply Recommendations



Copyright © 2016, Texas Instruments Incorporated

Figure 14. System Reset Controller With Undervoltage Sensing

When the TL770xB SENSE terminal is used to monitor V_{CC} , TI recommends a current-limiting resistor in series with C_T . During normal operation, the timing capacitor is charged by the onboard current source to approximately V_{CC} or an internal voltage clamp ($\approx 7.1\text{-V}$ Zener), whichever is less. When the circuit then is subjected to an undervoltage condition during which V_{CC} is rapidly slewed down, the voltage on CT exceeds that on V_{CC} . This forward biases a secondary path internally, which falsely activates the outputs. A fault is indicated when V_{CC} drops below $V_{(CT)}$, not when V_{SENSE} falls below V_{T-} .

Adding the external resistor, R_T , prevents false triggering. Its value is calculated as follows:

$$(V_{(CT)} - V_{T-}) / R_T$$

where

- $V_{(CT)} = V_{CC}$ or 7.1 V, whichever is less
 - $V_{T-} = 4.55\text{ V (nom)}$
 - $R_T =$ value of series resistor required
- (1)

For $V_{CC} = 5\text{ V}$

$$(5 - 4.55) / R_T < 1\text{ mA}$$
(2)

Therefore,

$$R_T > 450\ \Omega$$
(3)

Using a 20%-tolerance resistor, R_T should be greater than 560 Ω .

Adding this series resistor changes the duration of the reset pulse by no more than 10%. R_T extends the discharge of C_T , but also skews the $V_{(CT)}$ threshold. These effects tend to cancel one another. The precise percentage change can be derived theoretically, but the equation is complicated by this interaction and is dependent upon the duration of the supply-voltage fault condition.

Both outputs of the TL770xB must be terminated with similar value resistors, even when only one is being used. This prevents unwanted plateauing in either output waveform during switching, which may be interpreted as an undefined state or delay system reset.

11 Layout

11.1 Layout Guidelines

Figure 15 shows an example layout for the TL7705B device. As the $\overline{\text{RESET}}$ and RESET pins are open collector outputs, place pullup and pulldown resistors on the $\overline{\text{RESET}}$ and RESET pins respectively. A capacitor must be placed on the REF pin to stabilize the reference. This can help to prevent false triggering if noise couples into the reference.

11.2 Layout Example

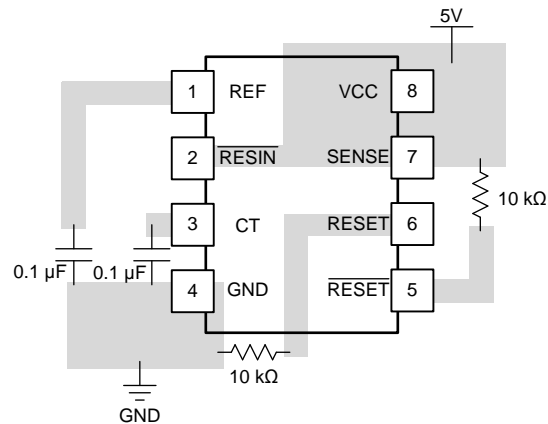

Figure 15. TL7705B Layout Example

12 Device and Documentation Support

12.1 Related Links

The table below lists quick access links. Categories include technical documents, support and community resources, tools and software, and quick access to sample or buy.

Table 1. Related Links

PARTS	PRODUCT FOLDER	SAMPLE & BUY	TECHNICAL DOCUMENTS	TOOLS & SOFTWARE	SUPPORT & COMMUNITY
TL7702B	Click here	Click here	Click here	Click here	Click here
TL7705B	Click here	Click here	Click here	Click here	Click here
TL7733B	Click here	Click here	Click here	Click here	Click here

12.2 Receiving Notification of Documentation Updates

To receive notification of documentation updates, navigate to the device product folder on ti.com. In the upper right corner, click on *Alert me* to register and receive a weekly digest of any product information that has changed. For change details, review the revision history included in any revised document.

12.3 Community Resources

The following links connect to TI community resources. Linked contents are provided "AS IS" by the respective contributors. They do not constitute TI specifications and do not necessarily reflect TI's views; see TI's [Terms of Use](#).

TI E2E™ Online Community *TI's Engineer-to-Engineer (E2E) Community*. Created to foster collaboration among engineers. At e2e.ti.com, you can ask questions, share knowledge, explore ideas and help solve problems with fellow engineers.

Design Support *TI's Design Support* Quickly find helpful E2E forums along with design support tools and contact information for technical support.

12.4 Trademarks

E2E is a trademark of Texas Instruments.
All other trademarks are the property of their respective owners.

12.5 Electrostatic Discharge Caution



This integrated circuit can be damaged by ESD. Texas Instruments recommends that all integrated circuits be handled with appropriate precautions. Failure to observe proper handling and installation procedures can cause damage.

ESD damage can range from subtle performance degradation to complete device failure. Precision integrated circuits may be more susceptible to damage because very small parametric changes could cause the device not to meet its published specifications.

12.6 Glossary

[SLYZ022](#) — *TI Glossary*.

This glossary lists and explains terms, acronyms, and definitions.

13 Mechanical, Packaging, and Orderable Information

The following pages include mechanical, packaging, and orderable information. This information is the most current data available for the designated devices. This data is subject to change without notice and revision of this document. For browser-based versions of this data sheet, refer to the left-hand navigation.

PACKAGING INFORMATION

Orderable Device	Status (1)	Package Type	Package Drawing	Pins	Package Qty	Eco Plan (2)	Lead/Ball Finish (6)	MSL Peak Temp (3)	Op Temp (°C)	Device Marking (4/5)	Samples
TL7702BCD	ACTIVE	SOIC	D	8	75	Green (RoHS & no Sb/Br)	CU NIPDAU	Level-1-260C-UNLIM	0 to 70	7702BC	Samples
TL7702BCDR	ACTIVE	SOIC	D	8	2500	Green (RoHS & no Sb/Br)	CU NIPDAU	Level-1-260C-UNLIM	0 to 70	7702BC	Samples
TL7702BCDRE4	ACTIVE	SOIC	D	8	2500	Green (RoHS & no Sb/Br)	CU NIPDAU	Level-1-260C-UNLIM	0 to 70	7702BC	Samples
TL7702BCDRG4	ACTIVE	SOIC	D	8	2500	Green (RoHS & no Sb/Br)	CU NIPDAU	Level-1-260C-UNLIM	0 to 70	7702BC	Samples
TL7702BCP	ACTIVE	PDIP	P	8	50	Green (RoHS & no Sb/Br)	CU NIPDAU	N / A for Pkg Type	0 to 70	TL7702BCP	Samples
TL7702BCPE4	ACTIVE	PDIP	P	8	50	Green (RoHS & no Sb/Br)	CU NIPDAU	N / A for Pkg Type	0 to 70	TL7702BCP	Samples
TL7702BID	ACTIVE	SOIC	D	8	75	Green (RoHS & no Sb/Br)	CU NIPDAU	Level-1-260C-UNLIM	-40 to 85	7702BI	Samples
TL7702BIDR	ACTIVE	SOIC	D	8	2500	Green (RoHS & no Sb/Br)	CU NIPDAU	Level-1-260C-UNLIM	-40 to 85	7702BI	Samples
TL7702BIP	ACTIVE	PDIP	P	8	50	Green (RoHS & no Sb/Br)	CU NIPDAU	N / A for Pkg Type	-40 to 85	TL7702BIP	Samples
TL7705BCD	ACTIVE	SOIC	D	8	75	Green (RoHS & no Sb/Br)	CU NIPDAU	Level-2-260C-1 YEAR	0 to 70	7705BC	Samples
TL7705BCDR	ACTIVE	SOIC	D	8	2500	Green (RoHS & no Sb/Br)	CU NIPDAU	Level-2-260C-1 YEAR	0 to 70	7705BC	Samples
TL7705BCDRE4	ACTIVE	SOIC	D	8	2500	Green (RoHS & no Sb/Br)	CU NIPDAU	Level-2-260C-1 YEAR	0 to 70	7705BC	Samples
TL7705BCDRG4	ACTIVE	SOIC	D	8	2500	Green (RoHS & no Sb/Br)	CU NIPDAU	Level-2-260C-1 YEAR	0 to 70	7705BC	Samples
TL7705BCP	ACTIVE	PDIP	P	8	50	Green (RoHS & no Sb/Br)	CU NIPDAU	N / A for Pkg Type	0 to 70	TL7705BCP	Samples
TL7705BID	ACTIVE	SOIC	D	8	75	Green (RoHS & no Sb/Br)	CU NIPDAU	Level-2-260C-1 YEAR	-40 to 85	7705BI	Samples
TL7705BIDE4	ACTIVE	SOIC	D	8	75	Green (RoHS & no Sb/Br)	CU NIPDAU	Level-2-260C-1 YEAR	-40 to 85	7705BI	Samples
TL7705BIDR	ACTIVE	SOIC	D	8	2500	Green (RoHS & no Sb/Br)	CU NIPDAU	Level-2-260C-1 YEAR	-40 to 85	7705BI	Samples

Orderable Device	Status (1)	Package Type	Package Drawing	Pins	Package Qty	Eco Plan (2)	Lead/Ball Finish (6)	MSL Peak Temp (3)	Op Temp (°C)	Device Marking (4/5)	Samples
TL7705BIP	ACTIVE	PDIP	P	8	50	Green (RoHS & no Sb/Br)	CU NIPDAU	N / A for Pkg Type	-40 to 85	TL7705BIP	Samples
TL7705BQD	ACTIVE	SOIC	D	8	75	Green (RoHS & no Sb/Br)	CU NIPDAU	Level-1-260C-UNLIM	-40 to 125	7705BQ	Samples
TL7705BQDG4	ACTIVE	SOIC	D	8	75	Green (RoHS & no Sb/Br)	CU NIPDAU	Level-1-260C-UNLIM		7705BQ	Samples
TL7705BQDR	ACTIVE	SOIC	D	8	2500	Green (RoHS & no Sb/Br)	CU NIPDAU	Level-1-260C-UNLIM	-40 to 125	7705BQ	Samples
TL7705BQDRG4	ACTIVE	SOIC	D	8	2500	Green (RoHS & no Sb/Br)	CU NIPDAU	Level-1-260C-UNLIM		7705BQ	Samples
TL7733BCD	ACTIVE	SOIC	D	8	75	Green (RoHS & no Sb/Br)	CU NIPDAU	Level-1-260C-UNLIM	0 to 70	7733BC	Samples
TL7733BCDE4	ACTIVE	SOIC	D	8	75	Green (RoHS & no Sb/Br)	CU NIPDAU	Level-1-260C-UNLIM	0 to 70	7733BC	Samples
TL7733BCDG4	ACTIVE	SOIC	D	8	75	Green (RoHS & no Sb/Br)	CU NIPDAU	Level-1-260C-UNLIM	0 to 70	7733BC	Samples
TL7733BCDR	ACTIVE	SOIC	D	8	2500	Green (RoHS & no Sb/Br)	CU NIPDAU	Level-1-260C-UNLIM	0 to 70	7733BC	Samples
TL7733BCDRE4	ACTIVE	SOIC	D	8	2500	Green (RoHS & no Sb/Br)	CU NIPDAU	Level-1-260C-UNLIM	0 to 70	7733BC	Samples
TL7733BCP	ACTIVE	PDIP	P	8	50	Green (RoHS & no Sb/Br)	CU NIPDAU	N / A for Pkg Type	0 to 70	TL7733BCP	Samples
TL7733BID	ACTIVE	SOIC	D	8	75	Green (RoHS & no Sb/Br)	CU NIPDAU	Level-1-260C-UNLIM	-40 to 85	7733BI	Samples
TL7733BIDG4	ACTIVE	SOIC	D	8	75	Green (RoHS & no Sb/Br)	CU NIPDAU	Level-1-260C-UNLIM	-40 to 85	7733BI	Samples
TL7733BIDR	ACTIVE	SOIC	D	8	2500	Green (RoHS & no Sb/Br)	CU NIPDAU	Level-1-260C-UNLIM	-40 to 85	7733BI	Samples
TL7733BIP	ACTIVE	PDIP	P	8	50	Green (RoHS & no Sb/Br)	CU NIPDAU	N / A for Pkg Type	-40 to 85	TL7733BIP	Samples

(1) The marketing status values are defined as follows:

ACTIVE: Product device recommended for new designs.

LIFEBUY: TI has announced that the device will be discontinued, and a lifetime-buy period is in effect.

NRND: Not recommended for new designs. Device is in production to support existing customers, but TI does not recommend using this part in a new design.

PREVIEW: Device has been announced but is not in production. Samples may or may not be available.

OBSOLETE: TI has discontinued the production of the device.

⁽²⁾ **RoHS:** TI defines "RoHS" to mean semiconductor products that are compliant with the current EU RoHS requirements for all 10 RoHS substances, including the requirement that RoHS substance do not exceed 0.1% by weight in homogeneous materials. Where designed to be soldered at high temperatures, "RoHS" products are suitable for use in specified lead-free processes. TI may reference these types of products as "Pb-Free".

RoHS Exempt: TI defines "RoHS Exempt" to mean products that contain lead but are compliant with EU RoHS pursuant to a specific EU RoHS exemption.

Green: TI defines "Green" to mean the content of Chlorine (Cl) and Bromine (Br) based flame retardants meet JS709B low halogen requirements of ≤ 1000 ppm threshold. Antimony trioxide based flame retardants must also meet the ≤ 1000 ppm threshold requirement.

⁽³⁾ MSL, Peak Temp. - The Moisture Sensitivity Level rating according to the JEDEC industry standard classifications, and peak solder temperature.

⁽⁴⁾ There may be additional marking, which relates to the logo, the lot trace code information, or the environmental category on the device.

⁽⁵⁾ Multiple Device Markings will be inside parentheses. Only one Device Marking contained in parentheses and separated by a "-" will appear on a device. If a line is indented then it is a continuation of the previous line and the two combined represent the entire Device Marking for that device.

⁽⁶⁾ Lead/Ball Finish - Orderable Devices may have multiple material finish options. Finish options are separated by a vertical ruled line. Lead/Ball Finish values may wrap to two lines if the finish value exceeds the maximum column width.

Important Information and Disclaimer: The information provided on this page represents TI's knowledge and belief as of the date that it is provided. TI bases its knowledge and belief on information provided by third parties, and makes no representation or warranty as to the accuracy of such information. Efforts are underway to better integrate information from third parties. TI has taken and continues to take reasonable steps to provide representative and accurate information but may not have conducted destructive testing or chemical analysis on incoming materials and chemicals. TI and TI suppliers consider certain information to be proprietary, and thus CAS numbers and other limited information may not be available for release.

In no event shall TI's liability arising out of such information exceed the total purchase price of the TI part(s) at issue in this document sold by TI to Customer on an annual basis.

TAPE AND REEL INFORMATION



QUADRANT ASSIGNMENTS FOR PIN 1 ORIENTATION IN TAPE



*All dimensions are nominal

Device	Package Type	Package Drawing	Pins	SPQ	Reel Diameter (mm)	Reel Width W1 (mm)	A0 (mm)	B0 (mm)	K0 (mm)	P1 (mm)	W (mm)	Pin1 Quadrant
TL7702BCDR	SOIC	D	8	2500	330.0	12.4	6.4	5.2	2.1	8.0	12.0	Q1
TL7702BIDR	SOIC	D	8	2500	330.0	12.4	6.4	5.2	2.1	8.0	12.0	Q1
TL7705BCDR	SOIC	D	8	2500	330.0	12.4	6.4	5.2	2.1	8.0	12.0	Q1
TL7705BIDR	SOIC	D	8	2500	330.0	12.4	6.4	5.2	2.1	8.0	12.0	Q1
TL7705BQDR	SOIC	D	8	2500	330.0	12.4	6.4	5.2	2.1	8.0	12.0	Q1
TL7705BQDRG4	SOIC	D	8	2500	330.0	12.4	6.4	5.2	2.1	8.0	12.0	Q1
TL7733BCDR	SOIC	D	8	2500	330.0	12.4	6.4	5.2	2.1	8.0	12.0	Q1
TL7733BIDR	SOIC	D	8	2500	330.0	12.4	6.4	5.2	2.1	8.0	12.0	Q1

TAPE AND REEL BOX DIMENSIONS

*All dimensions are nominal

Device	Package Type	Package Drawing	Pins	SPQ	Length (mm)	Width (mm)	Height (mm)
TL7702BCDR	SOIC	D	8	2500	340.5	338.1	20.6
TL7702BIDR	SOIC	D	8	2500	340.5	338.1	20.6
TL7705BCDR	SOIC	D	8	2500	340.5	338.1	20.6
TL7705BIDR	SOIC	D	8	2500	340.5	338.1	20.6
TL7705BQDR	SOIC	D	8	2500	350.0	350.0	43.0
TL7705BQDRG4	SOIC	D	8	2500	350.0	350.0	43.0
TL7733BCDR	SOIC	D	8	2500	340.5	338.1	20.6
TL7733BIDR	SOIC	D	8	2500	340.5	338.1	20.6



D0008A

PACKAGE OUTLINE

SOIC - 1.75 mm max height

SMALL OUTLINE INTEGRATED CIRCUIT



4214825/C 02/2019

NOTES:

- Linear dimensions are in inches [millimeters]. Dimensions in parenthesis are for reference only. Controlling dimensions are in inches. Dimensioning and tolerancing per ASME Y14.5M.
- This drawing is subject to change without notice.
- This dimension does not include mold flash, protrusions, or gate burrs. Mold flash, protrusions, or gate burrs shall not exceed $.006$ [0.15] per side.
- This dimension does not include interlead flash.
- Reference JEDEC registration MS-012, variation AA.

EXAMPLE BOARD LAYOUT

D0008A

SOIC - 1.75 mm max height

SMALL OUTLINE INTEGRATED CIRCUIT



LAND PATTERN EXAMPLE
 EXPOSED METAL SHOWN
 SCALE:8X



SOLDER MASK DETAILS

4214825/C 02/2019

NOTES: (continued)

- 6. Publication IPC-7351 may have alternate designs.
- 7. Solder mask tolerances between and around signal pads can vary based on board fabrication site.

EXAMPLE STENCIL DESIGN

D0008A

SOIC - 1.75 mm max height

SMALL OUTLINE INTEGRATED CIRCUIT



SOLDER PASTE EXAMPLE
BASED ON .005 INCH [0.125 MM] THICK STENCIL
SCALE:8X

4214825/C 02/2019

NOTES: (continued)

8. Laser cutting apertures with trapezoidal walls and rounded corners may offer better paste release. IPC-7525 may have alternate design recommendations.
9. Board assembly site may have different recommendations for stencil design.

P (R-PDIP-T8)

PLASTIC DUAL-IN-LINE PACKAGE

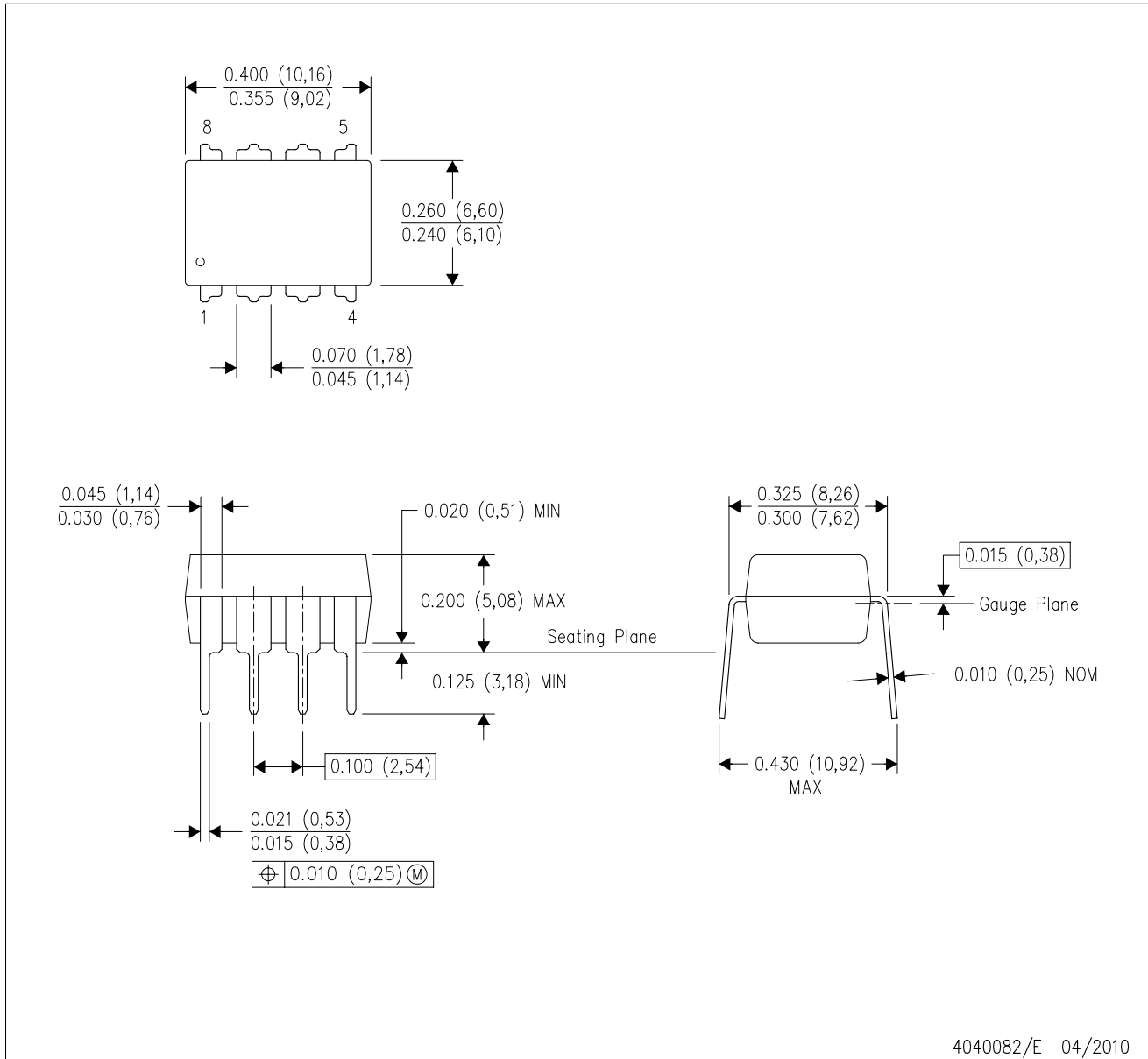

- NOTES:
- A. All linear dimensions are in inches (millimeters).
 - B. This drawing is subject to change without notice.
 - C. Falls within JEDEC MS-001 variation BA.

IMPORTANT NOTICE AND DISCLAIMER

TI PROVIDES TECHNICAL AND RELIABILITY DATA (INCLUDING DATASHEETS), DESIGN RESOURCES (INCLUDING REFERENCE DESIGNS), APPLICATION OR OTHER DESIGN ADVICE, WEB TOOLS, SAFETY INFORMATION, AND OTHER RESOURCES "AS IS" AND WITH ALL FAULTS, AND DISCLAIMS ALL WARRANTIES, EXPRESS AND IMPLIED, INCLUDING WITHOUT LIMITATION ANY IMPLIED WARRANTIES OF MERCHANTABILITY, FITNESS FOR A PARTICULAR PURPOSE OR NON-INFRINGEMENT OF THIRD PARTY INTELLECTUAL PROPERTY RIGHTS.

These resources are intended for skilled developers designing with TI products. You are solely responsible for (1) selecting the appropriate TI products for your application, (2) designing, validating and testing your application, and (3) ensuring your application meets applicable standards, and any other safety, security, or other requirements. These resources are subject to change without notice. TI grants you permission to use these resources only for development of an application that uses the TI products described in the resource. Other reproduction and display of these resources is prohibited. No license is granted to any other TI intellectual property right or to any third party intellectual property right. TI disclaims responsibility for, and you will fully indemnify TI and its representatives against, any claims, damages, costs, losses, and liabilities arising out of your use of these resources.

TI's products are provided subject to TI's Terms of Sale (www.ti.com/legal/termsofsale.html) or other applicable terms available either on ti.com or provided in conjunction with such TI products. TI's provision of these resources does not expand or otherwise alter TI's applicable warranties or warranty disclaimers for TI products.

Mailing Address: Texas Instruments, Post Office Box 655303, Dallas, Texas 75265
Copyright © 2019, Texas Instruments Incorporated

Looking for pricing, stock, or lifecycle information?

Click below to explore more details on WIN SOURCE:

 [View TL7705BID](#) on WIN SOURCE

 [Texas Instruments](#) Information

Optimize Your Supply Chain with WIN SOURCE Solutions

-  Global Sourcing Solution
-  Obsolete Management
-  Cost Control Management
-  Shortage Management
-  Alternative Solution
-  Excess Inventory Management