



**THE DATASHEET OF  
TPS65072RSLR**



# TPS65070x Power Management IC (PMIC) With Battery Charger, 3 Step-Down Converters, and 2 LDOs

## 1 Features

- Charger/Power Path Management:
  - 2-A Output Current on the Power Path
  - Linear Charger; 1.5-A Maximum Charge Current
  - 100-mA/500-mA/800-mA/1300-mA Current Limit From USB Input
  - Thermal Regulation, Safety Timers
  - Temperature Sense Input
- 3 Step-Down Converters:
  - 2.25-MHz Fixed-Frequency Operation
  - Up to 1.5 A of Output Current
  - Adjustable or Fixed Output Voltage
  - $V_{IN}$  Range From 2.8 V to 6.3 V
  - Power Save Mode at Light Load Current
  - Output Voltage Accuracy in PWM Mode  $\pm 1.5\%$
  - Typical 19- $\mu$ A Quiescent Current per Converter
  - 100% Duty Cycle for Lowest Dropout
- LDOs:
  - Fixed Output Voltage
  - Dynamic Voltage Scaling on LDO2
  - 20- $\mu$ A Quiescent Current
  - 200-mA Maximum Output Current
  - $V_{IN}$  Range From 1.8 V to 6.3 V
- wLED Boost Converter:
  - Internal Dimming Using I2C
  - Up to 2  $\times$  10 LEDs
  - Up to 25 mA per String With Internal Current Sink
- I<sup>2</sup>C Interface
- 10 Bit A/D Converter
- Touch Screen Interface
- Undervoltage Lockout and Battery Fault Comparator

## 2 Applications

- Portable Navigation Systems
- PDAs, Pocket PCs
- OMAP™ and Low Power DSP Supplies

## 3 Description

The TPS6507x family of devices are single-chip power management ICs (PMICs) for portable applications consisting of a battery charger with power path management for a single Li-Ion or Li-Polymer cell. The charger can either be supplied by a USB port on pin *USB* or by a DC voltage from a wall adapter connected to pin *AC*. Three highly efficient 2.25-MHz step-down converters are targeted at providing the core voltage, memory, and I/O voltage in a processor-based system. The step-down converters enter a low power mode at light load for maximum efficiency across the widest possible range of load currents.

### Device Information<sup>(1)</sup>

PART NUMBER	PACKAGE	BODY SIZE (NOM)
TPS65070x	VQFN (48)	6.00 mm x 6.00 mm

(1) For all available packages, see the orderable addendum at the end of the data sheet.

### Block Diagram

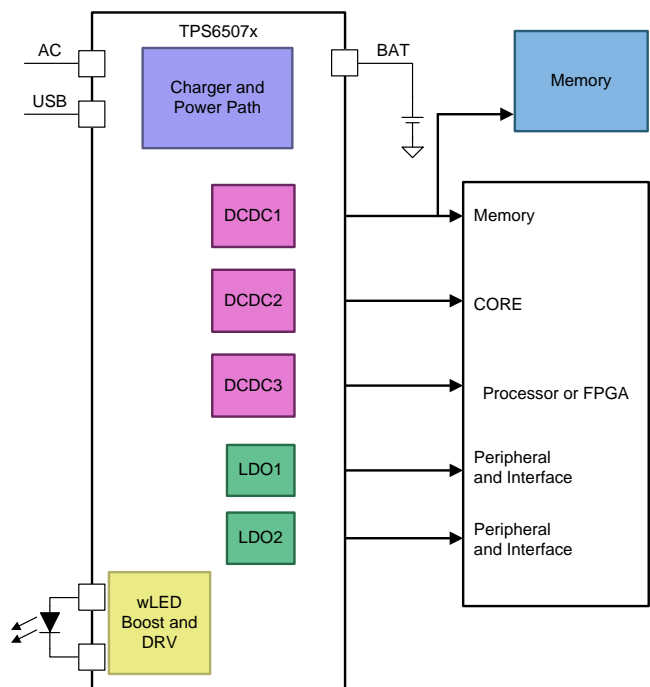

## Table of Contents

<b>1</b>	<b>Features</b> .....	<b>1</b>	8.17	Dissipation Ratings .....	<b>18</b>
<b>2</b>	<b>Applications</b> .....	<b>1</b>	8.18	Typical Characteristics .....	<b>19</b>
<b>3</b>	<b>Description</b> .....	<b>1</b>	<b>9</b>	<b>Parameter Measurement Information</b> .....	<b>23</b>
<b>4</b>	<b>Revision History</b> .....	<b>2</b>	<b>10</b>	<b>Detailed Description</b> .....	<b>24</b>
<b>5</b>	<b>Description (continued)</b> .....	<b>4</b>	10.1	Overview .....	<b>24</b>
<b>6</b>	<b>Device Options</b> .....	<b>4</b>	10.2	Functional Block Diagram .....	<b>24</b>
<b>7</b>	<b>Pin Configuration and Functions</b> .....	<b>5</b>	10.3	Feature Description .....	<b>25</b>
<b>8</b>	<b>Specifications</b> .....	<b>7</b>	10.4	Device Functional Modes .....	<b>40</b>
8.1	Absolute Maximum Ratings .....	<b>7</b>	10.5	Programming .....	<b>41</b>
8.2	ESD Ratings .....	<b>7</b>	10.6	Register Maps .....	<b>43</b>
8.3	Recommended Operating Conditions .....	<b>7</b>	<b>11</b>	<b>Application and Implementation</b> .....	<b>64</b>
8.4	Thermal Information .....	<b>9</b>	11.1	Application Information .....	<b>64</b>
8.5	Electrical Characteristics .....	<b>9</b>	11.2	Typical Applications .....	<b>66</b>
8.6	Electrical Characteristics - DCDC1 Converter .....	<b>10</b>	<b>12</b>	<b>Power Supply Recommendations</b> .....	<b>87</b>
8.7	Electrical Characteristics - DCDC2 Converter .....	<b>11</b>	<b>13</b>	<b>Layout</b> .....	<b>88</b>
8.8	Electrical Characteristics - DCDC3 Converter .....	<b>12</b>	13.1	Layout Guidelines .....	<b>88</b>
8.9	Electrical Characteristics - VLDO1 and VLDO2 Low Dropout Regulators .....	<b>13</b>	13.2	Layout Example .....	<b>88</b>
8.10	Electrical Characteristics - wLED Boost Converter .....	<b>14</b>	<b>14</b>	<b>Device and Documentation Support</b> .....	<b>89</b>
8.11	Electrical Characteristics - $\overline{\text{Reset}}$ , $\overline{\text{PB\_IN}}$ , $\overline{\text{PB\_OUT}}$ , PGood, Power_on, INT, EN_EXTLDO, EN_wLED ..	<b>14</b>	14.1	Device Support .....	<b>89</b>
8.12	Electrical Characteristics - ADC Converter .....	<b>15</b>	14.2	Documentation Support .....	<b>89</b>
8.13	Electrical Characteristics - Touch Screen Interface .....	<b>15</b>	14.3	Related Links .....	<b>89</b>
8.14	Electrical Characteristics - Power Path .....	<b>15</b>	14.4	Receiving Notification of Documentation Updates .....	<b>89</b>
8.15	Electrical Characteristics - Battery Charger .....	<b>17</b>	14.5	Community Resources .....	<b>89</b>
8.16	Timing Requirements .....	<b>18</b>	14.6	Trademarks .....	<b>90</b>
			14.7	Electrostatic Discharge Caution .....	<b>90</b>
			14.8	Glossary .....	<b>90</b>
			<b>15</b>	<b>Mechanical, Packaging, and Orderable Information</b> .....	<b>90</b>

## 4 Revision History

NOTE: Page numbers for previous revisions may differ from page numbers in the current version.

Changes from Revision H (September 2015) to Revision I	Page
• Changed the title of the data sheet .....	<b>1</b>
• Changed the pin number column headers from TPS65072 and TPS6507x to TPS6507x and TPS65072 in the <i>Pin Functions</i> table .....	<b>5</b>
• Changed the <i>Electrostatic Discharge Caution</i> statement .....	<b>89</b>

Changes from Revision G (May 2013) to Revision H	Page
• Added <i>ESD Ratings</i> table, <i>Feature Description</i> section, <i>Device Functional Modes</i> , <i>Application and Implementation</i> section, <i>Power Supply Recommendations</i> section, <i>Layout</i> section, <i>Device and Documentation Support</i> section, and <i>Mechanical, Packaging, and Orderable Information</i> section .....	<b>1</b>

Changes from Revision F (July 2012) to Revision G	Page
• Changed the PPATH1. Register Address: 01h section table. Default row From: xx00011 To: xx00110 .....	<b>44</b>

---

**Changes from Revision E (February) to Revision F** **Page**

---

- Added TPS650701 and TPS650721 device specs to the data sheet ..... **4**
- 

**Changes from Revision C (August 2011) to Revision D** **Page**

---

- Changed text in the Low Dropout Voltage Regulators section, second paragraph – the sentence "The output voltage for LDO1 is defined by the settings in Register DEFLDO1" to "The output voltage for LDO1 is defined by the settings in Register LDO\_CTRL1" ..... **36**
- 

**Changes from Revision B (December 2009) to Revision C** **Page**

---

- Changed Input Current Limit MIN value from 2000 to 1900 for  $I_{AC2500}$  specification..... **16**
  - Changed  $K_{ISET}$  spec MIN/TYP/MAX values from 840/900/1000 to 820/950/1080 respectively for a charge current of 1500 mA ..... **17**
  - Changed  $K_{ISET}$  spec MIN/TYP/MAX values from 930/1100/1200 to 890/1050/1200 respectively for a charge current of 100 mA ..... **17**
- 

**Changes from Revision A (August 2009) to Revision B** **Page**

---

- Changed title from ".....Navigation Systems" to ".....Battery Powered Systems" ..... **1**
  - Changed status of TPS65072RSL device to Production Data ..... **4**
  - Deleted "Product Preview" from TPS65072 pinout graphic ..... **5**
  - Changed  $V_{OUT}$  Parameter from: "Fixed output voltage; PFM mode" to: "DC output voltage accuracy; PFM mode" ..... **11**
  - Changed  $V_{OUT}$  Parameter from: "Fixed output voltage; PWM mode" to: "DC output voltage accuracy; PWM mode" ..... **11**
  - Changed part number from TPS65072 to TPS650732 at the DCDC3 Converter  $V_{OUT}$  Default output voltage spec. to correct typo error ..... **12**
  - Changed  $V_{OUT}$  Parameter from: "Fixed output voltage; PFM mode" to: "DC output voltage accuracy; PFM mode" ..... **12**
  - Changed  $V_{OUT}$  Parameter from: "Fixed output voltage; PWM mode" to: "DC output voltage accuracy; PWM mode" ..... **12**
  - Added test conditions for  $I_{DISCH}$  specification..... **15**
  - Deleted "Product Preview" cross reference and Tablenote with reference to device TPS65072 ..... **31**
  - Changed TSC equations in Table 3 to correct typographical errors ..... **38**
  - Added  $X_{pos} = ADRESULT / 1024$  to X position Equation list of Table 3..... **39**
  - Added  $Y_{pos} = ADRESULT / 1024$  to Y position Equation list of Table 3..... **39**
  - Added Sub-section *Performing Measurements Using the Touch Screen Controller* for Programmers benefit ..... **39**
  - Changed Bit 7 explanation from '*...when input voltage at pin AC detected*' to '*...when no input voltage at pin AC is detected*' ..... **49**
  - Changed Bit 0 explanation from '*...when input voltage at pin AC detected*' to '*...when no input voltage at pin AC is detected*' ..... **49**
  - Deleted "Product Preview" status & footnote for the TPS65072 device listing. .... **64**
  - Deleted "Product Preview" footnote in reference to the TPS65072 device status..... **77**
  - Changed Schematic entity part number from OMAP3505 to AM3505..... **86**
-

## 5 Description (continued)

For low noise applications the devices can be forced into fixed-frequency PWM using the I<sup>2</sup>C interface. The step-down converters allow the use of small inductors and capacitors to achieve a small solution size. The TPS6507x devices also integrate two general purpose LDOs for an output current of 200 mA. These LDOs can be used to power an SD-card interface and an *always-on* rail, but can be used for other purposes as well. Each LDO operates with an input voltage range from 1.8 V to 6.3 V allowing them to be supplied from one of the step-down converters or directly from the main battery. An inductive boost converter with two programmable current sinks power two strings of white LEDs.

The TPS6507x devices come in a 48-pin leadless package (6-mm × 6-mm VQFN) with a 0.4-mm pitch.

## 6 Device Options

OUTPUT VOLTAGE AT DCDC3	OUTPUT VOLTAGE AT DCDC1 / DCDC2	OUTPUT VOLTAGE AT LDO1 / LDO2	OUTPUT CURRENT AT DCDC1 / DCDC2 / DCDC3	PGOOD, RESET DELAY	TOUCH SCREEN CONTROLLER	PART NUMBER <sup>(1)</sup>
1 V / 1.2 V (OMAP-L1x8)	3.3 V 1.8 V / 3.3 V	1.8 V / 1.2 V	0.6 A / 1.5 A / 1.5 A	400 ms	Yes	TPS65070RSL
1.2 V / 1.4 V (Atlas IV)	3.3 V 1.8 V / 2.5 V	1.2 V / 1.2 V	3 x 600 mA	20 ms	No	TPS65072RSL
1.2 V / 1.35 V (OMAP35xx)	1.8 V 1.2 V / 1.8 V	1.8 V / 1.8 V	0.6 A / 0.6 A / 1.5 A External sequencing	400 ms	Yes	TPS65073RSL
1.2 V / 1.35 V (OMAP35xx)	1.8 V 1.2 V / 1.8 V	1.8 V / 1.8 V	0.6 A / 0.6 A / 1.5 A Internal sequencing	400 ms	Yes	TPS650731RSL
1.2 V / 1.35 V (AM3505)	1.8 V 1.8 V / 3.3 V	1.8 V / 1.8 V	0.6 A / 0.6 A / 1.5 A Internal sequencing	400 ms	Yes	TPS650732RSL

- (1) The RSL package is available in tape and reel. Add R suffix (TPS65070RSLR) to order quantities of 2500 parts per reel. Add T suffix (TPS65070RSLT) to order quantities of 250 parts per reel.

## 7 Pin Configuration and Functions

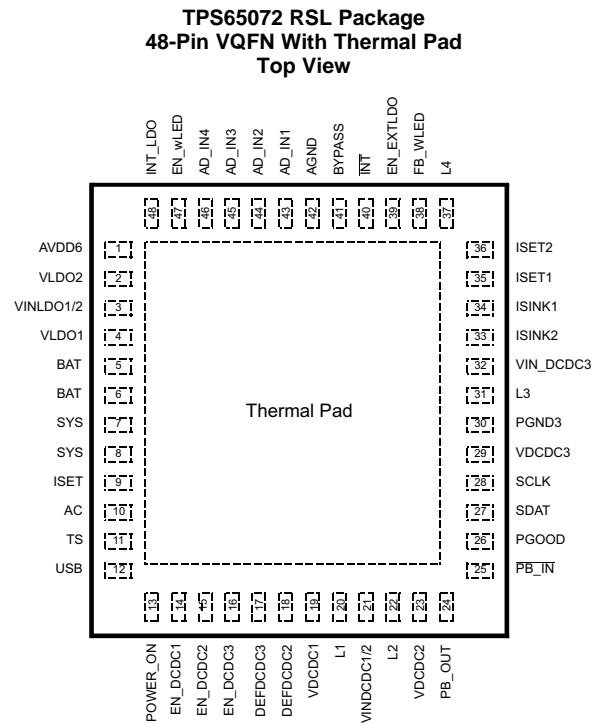
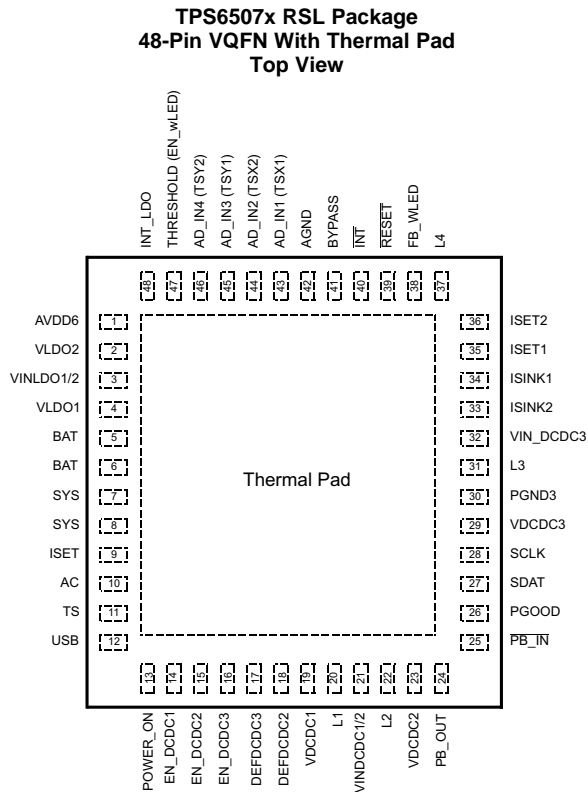

### Pin Functions

NAME	PIN NO.		I/O	DESCRIPTION
	TPS6507x	TPS65072		
<b>CHARGER BLOCK</b>				
AC	10	10	I	Input power for power path manager, connect to external DC supply. Connect external 1 $\mu$ F (minimum) to GND
AD_IN1 (TSX1)	43	43	I	Analog input1 for A/D converter; TPS65070, TPS65073, TPS650731, TPS650732 only: Input 1 to the x-plate for the touch screen.
AD_IN2 (TSX2)	44	44	I	Analog input2 for A/D converter; TPS65070, TPS65073, TPS650731, TPS650732 only: Input 2 to the x-plate for the touch screen
AD_IN3 (TSY1)	45	45	I	Analog input3 for A/D converter; TPS65070, TPS65073, TPS650731, TPS650732 only: Input 1 to the y-plate for the touch screen
AD_IN4 (TSY2)	46	46	I	Analog input4 for A/D converter; TPS65070, TPS65073, TPS650731, TPS650732 only: Input 2 to the y-plate for the touch screen
AVDD6	1	1	O	Internal "always-on"-voltage. Connect a 4.7- $\mu$ F capacitor from AVDD6 to GND
BAT	5, 6	5, 6	O	Charger power stage output, connect to battery. Place a ceramic capacitor of 10 $\mu$ F from these pins to GND
BYPASS	41	41	O	Connect a 10- $\mu$ F bypass capacitor from this pin to GND. This pin can optionally be used as a reference output (2.26 V). The maximum load on this pin is 0.1 mA.
$\overline{\text{INT}}$	40	40	O	Open-drain interrupt output. An interrupt can be generated upon: <ul style="list-style-type: none"> <li>• A touch of the touch screen</li> <li>• Voltage applied or removed at pins AC or USB</li> <li>• <math>\overline{\text{PB\_IN}}</math> actively pulled low (optionally actively pulled high)</li> </ul>
INT_LDO	48	48	O	Connect a 2.2- $\mu$ F bypass capacitor from this pin to GND. The pin is connected to an internal LDO providing the power for the touch screen controller (TSREF).
ISET	9	9	I	Connect a resistor from ISET to GND to set the charge current.

### Pin Functions (continued)

NAME	PIN		I/O	DESCRIPTION
	NO.			
	TPS6507x	TPS65072		
SCLK	28	28	I	Clock input for the I2C interface.
SDAT	27	27	I/O	Data line for the I2C interface.
SYS	7, 8	7, 8	O	System voltage; output of the power path manager. All voltage regulators are typically powered from this output.
TS	11	11	I	Temperature sense input. Connect to NTC thermistor to sense battery pack temperature. TPS6507x can be internally programmed to operate with a 10-kΩ curve 2 or 100-kΩ curve 1 thermistor. To linearize the thermistor response, use a 75-kΩ (for the 10-kΩ NTC) or a 360-kΩ (for the 100-kΩ NTC) in parallel with the thermistor. Default setting is 10-kΩ NTC.
USB	12	12	I	Input power for power path manager, connect to external voltage from a USB port. Connect external 1 μF (minimum) to GND. Default input current limit is 500 mA maximum.
<b>CONVERTERS</b>				
AGND	42	42	—	Analog GND, connect to PGND (thermal pad)
DEFDCDC2	18	18	I	Select Pin of DCDC2 output voltage.
DEFDCDC3	17	17	I	Select Pin of DCDC3 output voltage.
EN_DCDC1	14	14	I	Enable Input for DCDC1, active high
EN_DCDC2	15	15	I	Enable Input for DCDC2, active high
EN_DCDC3	16	16	I	Enable Input for DCDC3, active high
EN_EXTLDO	—	39	O	TPS65072: This pin is the active high, push-pull output to enable an external LDO. This pin will be set and reset during startup and shutdown by the sequencing option programmed. The output is pulled internally to the SYS voltage if HIGH. The output is only used for sequencing options for Sirf Prima or Atlas 4 processors with DCDC_SQ[2..0] = 100 or DCDC_SQ[2..0] = 111.
EN_wLED	—	47	I	TPS65072, : This pin is the actively high enable input for the wLED driver. The wLED converter is enabled by the ENABLE ISINK Bit OR enable EN_wLED pin.
FB_wLED	38	38	I	Feedback input for the boost converter's output voltage.
ISSET1 (AD_IN6)	35	35	I	Connect a resistor from this pin to GND to set the full scale current for Isink1 and Isink2 with Bit Current Level in register WLED_CTRL0 set to 1. Analog input6 for the A/D converter.
ISSET2 (AD_IN7)	36	36	I	Connect a resistor from this pin to GND to set the full scale current for Isink1 and Isink2 with Bit Current Level in register WLED_CTRL0 set to 0. Analog input7 for the A/D converter.
ISINK1	34	34	I	Input to the current sink 1. Connect the cathode of the LEDs to this pin.
ISINK2	33	33	I	Input to the current sink 2. Connect the cathode of the LEDs to this pin.
L1	20	20	O	Switch Pin for DCDC1. Connect to Inductor
L2	22	22	O	Switch Pin of DCDC2. Connect to Inductor.
L3	31	31	O	Switch Pin of DCDC3. Connect to Inductor.
L4	37	37	I	Switch Pin of the white LED (wLED) boost converter. Connect to Inductor and rectifier diode.
PB_IN	25	25	I	Enable input for TPS6507x. When pulled LOW, the DCDC converters and LDOs start with the sequencing as programmed internally. Internal 50kΩ pullup resistor to AVDD6
PB_OUT	24	24	O	Open-drain output. This pin is driven by the status of the /PB_IN input (after debounce). PB_OUT=LOW if PB_IN=LOW
PGND3	30	30	—	Power GND for DCDC3. Connect to PGND (thermal pad)
PGOOD	26	26	O	Open-drain power good output. The delay time equals the setting for $\overline{\text{Reset}}$ . The pin will go low depending on the setting in register PGOODMASK. Optionally it is also driven LOW for 0.5 ms when PB_IN is pulled LOW for >15s.
POWER_ON	13	13	I	Power_ON input for the internal state machine. After $\overline{\text{PB\_IN}}$ was pulled LOW to turn on the TPS6507x, the POWER_ON pin needs to be pulled HIGH by the application processor to keep the system in ON-state when $\overline{\text{PB\_IN}}$ is released HIGH. If POWER_ON is released LOW, the DCDC converters and LDOs will turn off when $\overline{\text{PB\_IN}}$ is HIGH.
$\overline{\text{RESET}}$	39	—	O	TPS65070, TPS65073, TPS650731, TPS650732: Open-drain active low reset output, reset delay time equals settings in register PGOOD. The status depends on the voltage applied at THRESHOLD.
THRESHOLD	47	—	I	TPS65070, TPS65073, TPS650731, TPS650732: Input for the reset comparator. $\overline{\text{RESET}}$ will be LOW if this voltage drops below 1 V.
VDCDC1	19	19	I	Feedback voltage sense input. For the fixed voltage option, this pin must directly be connected to Vout1, for the adjustable version, this pin is connected to an external resistor divider.
VDCDC2	23	23	I	Feedback voltage sense input, connect directly to Vout2

### Pin Functions (continued)

PIN			I/O	DESCRIPTION
NAME	NO.			
	TPS6507x	TPS65072		
VDCDC3	29	29	I	Feedback voltage sense input, connect directly to Vout3
VINDCDC1/2	21	21	I	Input voltage for DCDC1 and DCDC2 step-down converter. This pin must be connected to the SYS pin.
VINLDO1/2	3	3	I	Input voltage for LDO1 and LDO2
VIN_DCDC3	32	32	I	Input voltage for DCDC3 step-down converter. This pin must be connected to the SYS pin.
VLDO1	4	4	O	Output voltage of LDO1
VLDO2	2	2	O	Output voltage of LDO2
Thermal Pad			—	Power ground connection for the PMU. Connect to GND

## 8 Specifications

### 8.1 Absolute Maximum Ratings

over operating free-air temperature range (unless otherwise noted)<sup>(1)</sup>

		MIN	MAX	UNIT
Voltage	On all pins except the pins listed below with respect to AGND	−0.3	7	V
	On pins $\overline{\text{INT}}$ , $\overline{\text{RESET}}$ , PGOOD, PB_OUT with respect to AGND	−0.3	V(AVDD6)	
	On pins VINDCDC1/2, VINDCDC3, VINLDO respect to AGND	−0.3	V(SYS)	
	On pins AD_IN1, AD_IN2, AD_IN3, AD_IN4 with respect to AGND	−0.3	3.3	
	On pins ISINK1, ISINK2, AC, USB	−0.3	20	
	On pin L4 (output voltage of boost converter), FB_wLED	−0.3	40	
Current	In/Out at SYS, AC, USB, BAT, L3		3000	mA
	In/Out at all other pins		1000	mA
Power	Continuous total power dissipation	See <a href="#">Dissipation Ratings</a> <sup>(2)</sup>		
Temperature	Operating free-air temperature, T <sub>A</sub>	40	85	°C
	Maximum junction temperature, T <sub>J</sub>		125	°C
	Storage temperature, T <sub>stg</sub>	−65	150	°C

- (1) Stresses beyond those listed under *Absolute Maximum Ratings* may cause permanent damage to the device. These are stress ratings only and functional operation of the device at these or any other conditions beyond those indicated under *Recommended Operating Conditions* is not implied. Exposure to absolute-maximum-rated conditions for extended periods may affect device reliability.
- (2) The thermal resistance R<sub>θJP</sub> junction to thermal pad of the RSL package is 1.1 K/W. The value for R<sub>θJA</sub> was measured on a high K board.

### 8.2 ESD Ratings

		VALUE	UNIT
V <sub>(ESD)</sub> Electrostatic discharge	Human body model (HBM), per ANSI/ESDA/JEDEC JS-001, all pins <sup>(1)</sup>	±2000	V
	Charged device model (CDM), per JEDEC specification JESD22-C101, all pins <sup>(2)</sup>	±500	

- (1) JEDEC document JEP155 states that 500-V HBM allows safe manufacturing with a standard ESD control process.
- (2) JEDEC document JEP157 states that 250-V CDM allows safe manufacturing with a standard ESD control process.

### 8.3 Recommended Operating Conditions

		MIN	NOM	MAX	UNIT
<b>BATTERY CHARGER AND POWER PATH</b>					
V <sub>IN</sub>	Input voltage for power path manager at pins AC or USB	4.3		17	V
	Input voltage for power path manager at pins AC or USB, charger and power path active (no overvoltage lockout)	4.3		5.8	
	Input voltage for power path manager at pins AC or USB in case there is no battery connected at pin BAT	3.6		17	
I <sub>IN</sub>	Input current at AC pin			2.5	A
	Input current at USB pin			1.3	

## Recommended Operating Conditions (continued)

		MIN	NOM	MAX	UNIT
$I_{BAT}$	Current at BAT pin			2	A
<b>DCDC CONVERTERS AND LDOs</b>					
$V_{INDCDC}$	Input voltage range for step-down converter DCDC1, DCDC2, DCDC3	2.8		6.3 <sup>(1)</sup>	V
$V_{DCDC1}$	Output voltage range for VDCDC1 step-down converter	0.6		$V_{INDCDC1}$	V
$V_{DCDC2}$	Output voltage range for VDCDC2, DCDC3 step-down converter	0.6		$V_{INDCDC2}$	V
$V_{INLDOx}$	Input voltage range for LDO1 and LDO2	1.8		6.3 <sup>(1)</sup>	V
$V_{LDO1}$	Output voltage range for LDO1	0.9		3.3	V
$V_{LDO2}$	Output voltage range for LDO2	0.8		3.3	V
$I_{OUTDCDC1}$	Output current at L1; except TPS650701		600		mA
$I_{OUTDCDC1}$	Output current at L1 for TPS650701		1200		mA
L1	Inductor at L1 <sup>(2)</sup>	1.5	2.2		μH
$C_{INDCDC12}$	Input Capacitor at $V_{INDCDC1}$ and $V_{INDCDC2}$ <sup>(2)</sup>	22			μF
$C_{OUTDCDC1}$	Output Capacitor at VDCDC1 <sup>(2)</sup>	10	22		μF
$I_{OUTDCDC2}$	Output current at L2;		1500		mA
L2	Inductor at L2 <sup>(2)</sup>	1.5	2.2		μH
$C_{OUTDCDC2}$	Output Capacitor at VDCDC2 <sup>(2)</sup>	10	22		μF
$I_{OUTDCDC3}$	Output current at L3;except TPS65072		1500		mA
$I_{OUTDCDC3}$	Output current at L3 for TPS65072		600		mA
L3	Inductor at L3 <sup>(2)</sup>	1.5	2.2		μH
$C_{INDCDC3}$	Input Capacitor at $V_{INDCDC3}$ <sup>(2)</sup>	10			μF
$C_{OUTDCDC3}$	Output Capacitor at VDCDC3 <sup>(2)</sup>	10	22		μF
L4	Inductor at L4 <sup>(2)</sup>		22		μH
$C_{OUTWLED}$	Output Capacitor at wLED boost converter	4.7			μF
$C_{INLDO1/2}$	Input Capacitor at $V_{INLDO1/2}$	2.2			μF
$C_{OUTLDO1}$	Output Capacitor at VLDO1	2.2			μF
$I_{OUTLDO1}$	Output Current at VLDO1		100		mA
$C_{OUTLDO2}$	Output Capacitor at VLDO2	2.2			μF
$I_{OUTLDO2}$	Output Current at VLDO2		100		mA
$C_{AC}$	Input Capacitor at AC	1			μF
$C_{USB}$	Input Capacitor at USB	1			μF
$C_{BAT}$	Capacitor at BAT pin	10			μF
$C_{SYS}$	Capacitor at SYS pin	22		100 <sup>(3)</sup>	μF
$C_{BYPASS}$	Capacitor at BYPASS pin	10			μF
$C_{INT\_LDO}$	Capacitor at INT_LDO pin	2.2			μF
$C_{AVDD6}$	Capacitor at AVDD6 pin	4.7			μF
$T_A$	Operating ambient temperature	−40		85	°C
$T_J$	Operating junction temperature	−40		125	°C

- (1) 6.3 V or  $V_{SYS}$  whichever is less.  
(2) See [Application Information](#) for more details.  
(3) For proper soft-start.

## 8.4 Thermal Information

THERMAL METRIC <sup>(1)</sup>		TPS65070x	UNIT
		RSL (VQFN)	
		48 PINS	
R <sub>θJA</sub>	Junction-to-ambient thermal resistance	30	°C/W
R <sub>θJC(top)</sub>	Junction-to-case (top) thermal resistance	16	°C/W
R <sub>θJB</sub>	Junction-to-board thermal resistance	5.3	°C/W
ψ <sub>JT</sub>	Junction-to-top characterization parameter	0.2	°C/W
ψ <sub>JB</sub>	Junction-to-board characterization parameter	5.3	°C/W
R <sub>θJC(bot)</sub>	Junction-to-case (bottom) thermal resistance	1	°C/W

(1) For more information about traditional and new thermal metrics, see the [Semiconductor and IC Package Thermal Metrics application report](#).

## 8.5 Electrical Characteristics

VSYS = 3.6 V, EN\_DCDCx = VSYS, L = 2.2 μH, C<sub>OUT</sub> = 10 μF, T<sub>A</sub> = –40°C to 85°C typical values are at T<sub>A</sub> = 25°C (unless otherwise noted)

PARAMETER	TEST CONDITIONS	MIN	TYP	MAX	UNIT
<b>SUPPLY CURRENT</b>					
V <sub>INDCDC</sub>	Input voltage range for DC-DC converters	2.8		6.3	V
I <sub>Q</sub>	Operating quiescent current Total current into VSYS, VINDCDCx, VINLDO1/2	Only DCDC2, DCDC3 and LDO1 enabled, device in ON-mode; DCDC converters in PFM		140	μA
		Per DC/DC converter, PFM mode		19 30	
		For LDO1 or LDO2 (either one enabled)		20 35	
		For LDO1 and LDO2 (both enabled)		34	mA
		For wLED converter		1.5	
Per DC/DC converter, PWM mode		2.5			
I <sub>SD</sub>	Shutdown current	All converters, LDOs, wLED driver and ADC disabled, no input voltage at AC and USB; SYS voltage turned off		8 12	μA
V <sub>UVLO</sub>	Undervoltage lockout threshold	–2%	2.8 3 3.1 3.25	2%	V
	Undervoltage lockout hysteresis	Rising voltage defined with <UVLO hysteresis>; DEFAULT: 500 mV		360 450	mV
	Undervoltage lockout deglitch time	Due to internal delay		4	ms
T <sub>SD</sub>	Thermal shutdown for DCDC converters, wLED driver and LDOs	Increasing junction temperature		150	°C
	Thermal shutdown hysteresis	Decreasing junction temperature		20	°C
<b>EN_DCDC1, EN_DCDC2, EN_DCDC3, DEFDCDC2, DEFDCDC3, SDAT, SCLK, EN_wLED (optional)</b>					
V <sub>IH</sub>	High Level Input Voltage, EN_DCDC1, EN_DCDC2, EN_DCDC3, DEFDCDC2, DEFDCDC3, SDAT, SCLK, EN_wLED	1.2		V <sub>sys</sub>	V
V <sub>IL</sub>	Low Level Input Voltage, EN_DCDC1, EN_DCDC2, EN_DCDC3, DEFDCDC2, DEFDCDC3, SDAT, SCLK, EN_wLED	0		0.4	V
I <sub>IN</sub>	Input bias current, EN_DCDC1, EN_DCDC2, EN_DCDC3, DEFDCDC2, DEFDCDC3, SDAT, SCLK		0.01	1	μA

## 8.6 Electrical Characteristics - DCDC1 Converter

PARAMETER		TEST CONDITIONS	MIN	TYP	MAX	UNIT
$V_{VINDCDC1}$	Input voltage range	Connected to SYS pin	2.8		6.3	V
$I_O$	Maximum output		600			mA
$R_{DS(ON)}$	High side MOSFET ON-resistance	$VINDCDC1 = 2.8\text{ V}$		150	300	m $\Omega$
		$VINDCDC1 = 3.5\text{ V}$		120	200	
$I_{LH}$	High side MOSFET leakage current	$VINDCDC1 = 6.3\text{ V}$			2	$\mu\text{A}$
$R_{DS(ON)}$	Low side MOSFET ON-resistance	$VINDCDC1 = 2.8\text{ V}$		200	300	m $\Omega$
		$VINDCDC1 = 3.5\text{ V}$		160	180	
$I_{LL}$	Low side MOSFET leakage current	$V_{DS} = 6.3\text{ V}$			1	$\mu\text{A}$
$I_{LIMF}$	Forward current limit	for TPS65072, TPS65073, TPS650731, TPS650732	0.8	1.1	1.5	A
$I_{LIMF}$	Forward current limit	for TPS65070	1.1	1.6	2.2	A
$f_S$	Oscillator frequency		1.95	2.25	2.55	MHz
$V_{out}$	Fixed output voltage range	Internal resistor divider, I <sup>2</sup> C selectable	0.725		3.3	V
$V_{out}$	Default output voltage	For TPS65070, TPS65072		3.3		V
		For TPS65073, TPS650731, TPS650732		1.8		
$V_{out}$	DC output voltage accuracy; PFM mode <sup>(1)</sup>	$VINDCDC1 = VDCDC1 + 0.3\text{ V to }6.3\text{ V};$ $0\text{ mA} = I_O = 0.6\text{ A}$	-2%		3%	
$V_{out}$	DC output voltage accuracy; PWM mode <sup>(1)</sup>	$VINDCDC1 = VDCDC1 + 0.3\text{ V to }6.3\text{ V};$ $0\text{ mA} = I_O = 0.6\text{ A}$	-1.5%		1.5%	
$\Delta V_{OUT}$	Power save mode ripple voltage <sup>(2)</sup>	$I_{OUT} = 1\text{ mA}$ , PFM mode		40		mV <sub>pp</sub>
$t_{Start}$	Start-up time	Time from active EN to Start switching		170		$\mu\text{s}$
$t_{Ramp}$	$V_{OUT}$ ramp up time	Time to ramp from 5% to 95% of $V_{OUT}$		250		$\mu\text{s}$
	Power good threshold	rising voltage		$V_O - 5\%$		
	Power good threshold	falling voltage		$V_O - 10\%$		
$R_{DIS}$	Internal discharge resistor at L1		-35%	250	35%	$\Omega$

(1) Output voltage specification does not include tolerance of external voltage programming resistors. Output voltage in PFM mode is scaled to +1% of nominal value.

(2) Configuration L = 2.2  $\mu\text{H}$ ,  $C_{OUT} = 10\text{ }\mu\text{F}$

## 8.7 Electrical Characteristics - DCDC2 Converter

PARAMETER		TEST CONDITIONS	MIN	TYP	MAX	UNIT
$V_{VINDCDC2}$	Input voltage range	Connected to SYS pin	2.8		6.3	V
$I_O$	Maximum output current	TPS65072/73/731/732	600			mA
		TPS65070	1500			
$R_{DS(ON)}$	High side MOSFET ON-resistance	$V_{INDCDC2} = 2.8\text{ V}$	150		300	m $\Omega$
		$V_{INDCDC2} = 3.5\text{ V}$	120		200	
$I_{LH}$	High side MOSFET leakage current	$V_{INDCDC2} = 6.3\text{ V}$			2	$\mu\text{A}$
$R_{DS(ON)}$	Low side MOSFET ON-resistance	$V_{INDCDC2} = 2.8\text{ V}$	200		300	m $\Omega$
		$V_{INDCDC2} = 3.5\text{ V}$	160		180	
$I_{LL}$	Low side MOSFET leakage current	$V_{DS} = 6.3\text{ V}$			1	$\mu\text{A}$
$I_{LIMF}$	Forward current limit	TPS65072/73/731/732	0.8 1.1 1.5			A
		TPS65070	2.1 2.4 3.5			
$f_S$	Oscillator frequency		1.95	2.25	2.55	MHz
$V_{out}$	Adjustable output voltage range	External resistor divider	0.6		$V_{in}$	V
$V_{ref}$	Reference voltage		600			mV
$V_{out}$	Fixed output voltage range	Internal resistor divider, I <sup>2</sup> C selectable (Default setting)	0.725		3.3	V
$V_{out}$	Default output voltage for TPS65070, TPS650732, Default output voltage for TPS65072	For DEFDCDC2 = LOW	1.8			V
		For DEFDCDC2 = HIGH	3.3			
		For DEFDCDC2 = LOW	1.8			
		For DEFDCDC2 = HIGH	2.5			
$V_{out}$	Default output voltage for TPS65073, TPS650731	For DEFDCDC2 = LOW	1.2			V
		For DEFDCDC2 = HIGH	1.8			
$V_{out}$	DC output voltage accuracy; PFM mode <sup>(1)</sup> DC output voltage accuracy; PWM mode <sup>(1)</sup> DC output voltage accuracy with resistor divider at DEFDCDC2; PFM DC output voltage accuracy with resistor divider at DEFDCDC2; PWM	$V_{INDCDC2} = 2.8\text{ V to }6.3\text{ V};$ $0\text{ mA} = I_O = 1.5\text{ A}$	-2%		3%	
			-1.5%		1.5%	
		$V_{INDCDC2} = V_{DCDC2} + 0.3\text{ V (min }2.8\text{ V) to }6.3\text{ V};$ $0\text{ mA} = I_O = 1.5\text{ A}$	-2%		3%	
			-1%		1%	
$\Delta V_{OUT}$	Power save mode ripple voltage	$I_{OUT} = 1\text{ mA, PFM mode}^{(2)}$	40			mV <sub>pp</sub>
$t_{Start}$	Start-up time	Time from active EN to Start switching	170			$\mu\text{s}$
$t_{Ramp}$	$V_{OUT}$ ramp up time	Time to ramp from 5% to 95% of $V_{OUT}$	250			$\mu\text{s}$
	Power good threshold	rising voltage	$V_o - 5\%$			
	Power good threshold	falling voltage	$V_o - 10\%$			
$R_{DIS}$	Internal discharge resistor at L2		-35%	250	35%	$\Omega$

(1) Output voltage specification does not include tolerance of external voltage programming resistors. Output voltage in PFM mode is scaled to +1% of nominal value.

(2) Configuration L= 2.2  $\mu\text{H}$ ,  $C_{OUT} = 10\text{ }\mu\text{F}$

## 8.8 Electrical Characteristics - DCDC3 Converter

PARAMETER			TEST CONDITIONS	MIN	TYP	MAX	UNIT
$V_{\text{INDCDC3}}$	Input voltage range		Connected to SYS pin	2.8		6.3	V
$I_{\text{O}}$	Maximum output current	TPS65072,	$V_{\text{in}} > 2.8 \text{ V}$	600			mA
$I_{\text{O}}$	Maximum output current	TPS65070, TPS65073, TPS650731, TPS650732	$V_{\text{in}} > 2.8 \text{ V}$	1500			mA
$R_{\text{DS(ON)}}$	High side MOSFET ON-resistance		$V_{\text{INDCDC3}} = 2.8 \text{ V}$	150	300		m $\Omega$
			$V_{\text{INDCDC3}} = 3.5 \text{ V}$	120	200		
$I_{\text{LH}}$	High side MOSFET leakage current		$V_{\text{INDCDC3}} = 6.3 \text{ V}$		2		$\mu\text{A}$
$R_{\text{DS(ON)}}$	Low side MOSFET ON-resistance		$V_{\text{INDCDC3}} = 2.8 \text{ V}$	200	300		m $\Omega$
			$V_{\text{INDCDC3}} = 3.5 \text{ V}$	160	180		
$I_{\text{LL}}$	Low side MOSFET leakage current		$V_{\text{DS}} = 6.3 \text{ V}$		1		$\mu\text{A}$
$I_{\text{LIMF}}$	Forward current limit	TPS65072	$2.8 \text{ V} < V_{\text{INDCDC3}} < 6.3 \text{ V}$	0.8	1.1	1.5	A
$I_{\text{LIMF}}$	Forward current limit	TPS65070/73/731/732	$2.8 \text{ V} < V_{\text{INDCDC3}} < 6.3 \text{ V}$	2.1	2.4	3.5	A
$f_{\text{S}}$	Oscillator frequency			1.95	2.25	2.55	MHz
$V_{\text{out}}$	Adjustable output voltage range		External resistor divider	0.6		$V_{\text{in}}$	V
$V_{\text{ref}}$	Reference voltage				600		mV
$V_{\text{out}}$	Fixed output voltage range		Internal resistor divider, I <sup>2</sup> C selectable (Default setting)	0.725		3.3	V
$V_{\text{out}}$	Default output voltage for TPS65070		For DEFDCDC3 = LOW		1		V
			For DEFDCDC3 = HIGH		1.2		
$V_{\text{out}}$	Default output voltage for TPS65072		For DEFDCDC3 = LOW		1.2		V
			For DEFDCDC3 = HIGH		1.4		
$V_{\text{out}}$	Default output voltage for TPS65073, TPS650731, TPS650732		For DEFDCDC3 = LOW		1.2		V
			For DEFDCDC3 = HIGH		1.35		
$V_{\text{out}}$	DC output voltage accuracy; PFM mode <sup>(1)</sup>		$V_{\text{INDCDC3}} = 2.8 \text{ V to } 6.3 \text{ V};$ $0 \text{ mA} = I_{\text{O}} = 1.5 \text{ A}$	-2%		3%	
	DC output voltage accuracy; PWM mode <sup>(1)</sup>			-1.5%		1.5%	
$V_{\text{out}}$	DC output voltage accuracy with resistor divider at DEFDCDC3; PFM		$V_{\text{INDCDC3}} = V_{\text{DCDC3}} + 0.3 \text{ V (min } 2.8 \text{ V) to } 6.3 \text{ V};$ $0 \text{ mA} = I_{\text{O}} = 1.5 \text{ A}$	-2%		3%	
$V_{\text{out}}$	DC output voltage accuracy with resistor divider at DEFDCDC3; PWM			-1%		1%	
$\Delta V_{\text{OUT}}$	Power save mode ripple voltage		$I_{\text{OUT}} = 1 \text{ mA}$ , PFM mode <sup>(2)</sup>		40		mV <sub>pp</sub>
$t_{\text{Start}}$	Start-up time		Time from active EN to Start switching		170		$\mu\text{s}$
$t_{\text{Ramp}}$	$V_{\text{OUT}}$ ramp up time		Time to ramp from 5% to 95% of $V_{\text{OUT}}$		250		$\mu\text{s}$
	Power good threshold		rising voltage		$V_{\text{O}} - 5\%$		
	Power good threshold		falling voltage		$V_{\text{O}} - 10\%$		
$R_{\text{DIS}}$	Internal discharge resistor at L3			-35%	250	35%	$\Omega$

(1) Output voltage specification does not include tolerance of external voltage programming resistors. Output voltage in PFM mode is scaled to +1% of nominal value.

(2) Configuration L= 2.2  $\mu\text{H}$ ,  $C_{\text{OUT}} = 10 \mu\text{F}$

## 8.9 Electrical Characteristics - VLDO1 and VLDO2 Low Dropout Regulators

PARAMETER		TEST CONDITIONS	MIN	TYP	MAX	UNIT
$V_{INLDO}$	Input voltage range for LDO1, LDO2		1.8		6.3 <sup>(1)</sup>	V
$V_{LDO1}$	LDO1 output voltage range		1.0		3.3	V
$V_{LDO2}$	LDO2 output voltage range	Voltage options available see register description	0.725		3.3	V
$I_O$	Output current for LDO1				200	mA
$V_{LDO1}$	LDO1 default output voltage	For TPS65072		1.2		V
$V_{LDO1}$	LDO1 default output voltage	For TPS65070, TPS65073, TPS650731, TPS650732		1.8		V
$V_{LDO2}$	LDO2 default output voltage	For TPS65070		1.2		V
$V_{LDO2}$	LDO2 default output voltage	For TPS65072		1.2		V
$V_{LDO2}$	LDO2 default output voltage	For TPS65073, TPS650731, TPS650732		1.8		V
$I_O$	Output current for LDO2				200	mA
$I_{SC}$	LDO1 short circuit current limit	$V_{LDO1} = GND$			400	mA
$I_{SC}$	LDO2 short circuit current limit	$V_{LDO2} = GND$			400	mA
	Minimum voltage drop at LDO1	$I_O = 100\text{ mA}$ , $V_{INLDO} = 3.3\text{ V}$			150	mV
	Minimum voltage drop at LDO2	$I_O = 100\text{ mA}$ , $V_{INLDO} = 3.3\text{ V}$			150	mV
	Output voltage accuracy for LDO1, LDO2	ILDO1 = 100 mA; ILDO2 = 100 mA; $V_{in} = V_{out} + 200\text{ mV}$	-1%		1.5%	
	Line regulation for LDO1, LDO2	$V_{INLDO1,2} = V_{LDO1,2} + 0.5\text{ V}$ (min. 2.8 V) to 6.5 V, ILDO1 = 100 mA; ILDO2 = 100 mA	-1%		1%	
	Load regulation for LDO1, LDO2	$I_O = 1\text{ mA}$ to 200 mA	-1%		1%	
	Load regulation for LDO1, LDO2	$I_O < 1\text{ mA}$ ; $V_O < 1\text{ V}$	-2.5%		2.5%	
$R_{DIS}$	Internal discharge resistor at VLDO1, VLDO2			400		$\Omega$
$t_{Ramp}$	$V_{OUT}$ ramp up time	Time to ramp from 5% to 95% of $V_{OUT}$		250		$\mu\text{s}$

(1) 6.3 V or VSYS whichever is less

## 8.10 Electrical Characteristics - wLED Boost Converter

PARAMETER		TEST CONDITIONS	MIN	TYP	MAX	UNIT
V <sub>L4</sub>	voltage at L4 pin		2.8		39	V
V <sub>sink1,2</sub>	Input voltage at ISINK1, ISINK2 pins				16	V
V <sub>OUT</sub>	Internal overvoltage protection		35	37	39	V
	Maximum boost factor (V <sub>out</sub> /V <sub>in</sub> )	I <sub>sink1</sub> = I <sub>sink2</sub> = 20 mA, V <sub>in</sub> = 2.8 V	9	10		
T <sub>min_off</sub>	Minimum off pulse width			70		ns
R <sub>DS(ON)</sub>	N-channel MOSFET ON-resistance	V <sub>L4</sub> = 3.6 V		0.6		Ω
	N-channel MOSFET current limit		0.8	1.6	2	A
I <sub>LN_NFET</sub>	N-channel leakage current	V <sub>DS</sub> = 25 V, T <sub>A</sub> = 25°C			1	μA
	Switching frequency			1.125		MHz
V <sub>sink1</sub> , V <sub>sink2</sub>	Minimum voltage drop at Isink pin to GND for proper regulation			400		mV
V <sub>ISET</sub>	ISET pin voltage			1.24		V
K <sub>ISET</sub>	Current multiple I <sub>out</sub> /I <sub>set</sub>	I <sub>set</sub> current = 15 μA		1000		
		I <sub>set</sub> current = 25 μA		1000		
I <sub>sink1</sub> , I <sub>sink2</sub>	Minimum current into ISINK1, ISINK2 pins	For proper dimming (string can be disabled also)			4	mA
	Maximum current into ISINK1, ISINK2 pins	V <sub>in</sub> = 3.3 V		25		mA
	DC current set accuracy	I <sub>sinkx</sub> = 5 mA to 25 mA; no PWM dimming			±5%	
	Current difference between I <sub>sink1</sub> and I <sub>sink2</sub>	R <sub>set1</sub> = 50k; I <sub>sink1</sub> = 25 mA, V <sub>in</sub> = 3.6 V; no PWM dimming			±5%	
	Current difference between I <sub>sink1</sub> and I <sub>sink2</sub>	R <sub>set2</sub> = 250k; I <sub>sink1</sub> = 5 mA, V <sub>in</sub> = 3.6 V; no PWM dimming			±5%	
f <sub>PWM</sub>	PWM dimming frequency	PWM dimming Bit = 00	-15%	100	15%	Hz
		PWM dimming Bit = 01 (default)	-15%	200	15%	
		PWM dimming Bit = 10	-15%	500	15%	
		PWM dimming Bit = 11	-15%	1000	15%	
	Rise / fall time of PWM signal	For all PWM frequencies		2		μs
	Dimming PWM DAC resolution			1%		

## 8.11 Electrical Characteristics - $\overline{\text{Reset}}$ , $\overline{\text{PB\_IN}}$ , $\overline{\text{PB\_OUT}}$ , PGood, Power<sub>on</sub>, $\overline{\text{INT}}$ , EN\_EXTLDO, EN\_wLED

PARAMETER		TEST CONDITIONS	MIN	TYP	MAX	UNIT
	$\overline{\text{Reset}}$ delay time and PGOOD delay time	Input voltage at threshold pin rising; time defined with <PGOOD DELAY0>, <PGOOD DELAY1>	-15%	20 100 200 400	15%	ms
	PB-IN debounce time		-15%	50	15%	ms
	$\overline{\text{PB\_IN}}$ "Reset-detect- time"	Internal timer	-15%	15	15%	s
	PGOOD low time when $\overline{\text{PB\_IN}}$ = Low for >15s		-15%	0.5	15%	ms
V <sub>IH</sub>	High level input voltage on pin POWER_ON		1.2		V <sub>IN</sub>	V
V <sub>IH</sub>	High level input voltage on pin $\overline{\text{PB\_IN}}$		1.8		AVDD6	V
V <sub>IL</sub>	Low Level Input Voltage, $\overline{\text{PB\_IN}}$ , Power <sub>on</sub>		0		0.4	V
	Internal pullup resistor from $\overline{\text{PB\_IN}}$ to AVDD6			50		kΩ
	Output current at AVDD6				1	mA
I <sub>IN</sub>	Input bias current at Power <sub>on</sub>			0.01	1	μA
V <sub>OL</sub>	$\overline{\text{Reset}}$ , $\overline{\text{PB\_OUT}}$ , PGood, $\overline{\text{INT}}$ output low voltage, EN_EXTLDO	I <sub>OL</sub> = 1 mA, V <sub>threshold</sub> < 1 V			0.3	V
VOH	EN_EXTLDO HIGH level output voltage	I <sub>OH</sub> = 0.1 mA; optional push pull output			V <sub>SYS</sub>	V
I <sub>OL</sub>	$\overline{\text{Reset}}$ , $\overline{\text{PB\_OUT}}$ , PGood, $\overline{\text{INT}}$ sink current			1		mA
	$\overline{\text{Reset}}$ , $\overline{\text{PB\_OUT}}$ , PGood, $\overline{\text{INT}}$ output leakage current	$\overline{\text{Reset}}$ , $\overline{\text{PB\_OUT}}$ , PGood, $\overline{\text{INT}}$ open-drain output in high impedance state			0.25	μA
V <sub>th</sub>	Threshold voltage at THRESHOLD pin	Input voltage falling	-4%	1	4%	V
V <sub>th_hyst</sub>	Hysteresis on THRESHOLD pin	Input voltage rising		7		mV
I <sub>in</sub>	Input bias current at EN_wLED, THRESHOLD				1	μA

## 8.12 Electrical Characteristics - ADC Converter

PARAMETER		TEST CONDITIONS	MIN	TYP	MAX	UNIT
V <sub>IN</sub>	Input voltage range at AD_IN1 to AD_IN4 pin (channel 0 to channel 3)	For full scale measurement	0		2.25	V
	Input voltage range internal channel 6 to channel 9	For full scale measurement	0		6	
	Input voltage range on channel4 (TS pin) and channel5 (ISET pin)	Unipolar measurement of charge current at pin ISET (voltage at ISET)	0		2.25	
I <sub>in</sub>	AD_IN1 to AD_IN4 input current			0.1	4	μA
C <sub>in</sub>	Input capacitance at AD_IN1 to AD_IN4			15		pF
	ADC resolution			10		Bits
	Differential linearity error			±1		LSB
	Offset error			1	5	LSB
	Gain error			±8		LSB
	Sampling time			220		μs
	Conversion time			19		μs
	Wait time after enable	Time needed to stabilize the internal voltages	1.5			ms
	Quiescent current, ADC enabled by I <sup>2</sup> C	includes current needed for I2C block		500		μA
	Quiescent current, conversion ongoing				1	mA
	Reference voltage output on pin BYPASS		-1%	2.260	1%	V
	Output current on reference output pin BYPASS				0.1	mA

## 8.13 Electrical Characteristics - Touch Screen Interface

PARAMETER		TEST CONDITIONS	MIN	TYP	MAX	UNIT
V <sub>TSREF</sub>	Voltage at internal voltage regulator for TSC			2.30		V
<b>TOUCHSCREEN PANEL SPECIFICATIONS</b>						
	Plate resistance X	Specified by design	200	400	1200	Ω
	Plate resistance Y	Specified by design	200	400	1200	Ω
	Resistance between plates contact		180	400	1000	Ω
	Resistance between plates pressure		180	400	1000	Ω
	Settling time	Position measurement; 400 Ω, 100 pF		5.5		μs
	Capacitance between plates			2	10	nF
	Total capacitance at pins TSX1, TSX2, TSY1, TSY2 to GND				100	pF
	internal TSC reference resistance		20.9	22	23.1	kΩ
<b>SWITCH MATRIX SPECIFICATIONS</b>						
	Tgate resistance	Specified by design	111	160	230	Ω
	PMOS resistance	Specified by design			20	Ω
	NMOS resistance	Specified by design			20	Ω
	Quiescent supply current	in TSC standby mode with TSC_M[2..0] = 101		10		μA

## 8.14 Electrical Characteristics - Power Path

PARAMETER		TEST CONDITIONS	MIN	TYP	MAX	UNIT
<b>QUIESCENT CURRENT</b>						
I <sub>QSP1</sub>	Quiescent current, AC or USB mode	Current into AC or USB, AC or USB selected, no load at SYS			20	μA
<b>INPUT SUPPLY</b>						
V <sub>BATMIN</sub>	Minimum battery voltage for BAT SWITCH operation	No input power, BAT_SWITCH on	2.75			V
V <sub>IN(DT)</sub>	Input voltage detection threshold	AC detected when V(AC)-V(BAT) > V <sub>IN(DT)</sub> ; USB detected when V(USB)-V(BAT) > V <sub>IN(DT)</sub>	150			mV
V <sub>IN(NDT)</sub>	Input Voltage removal threshold	AC not detected when V(AC)-V(BAT) < V <sub>IN(NDT)</sub> ; USB not detected when V(USB)-V(BAT) < V <sub>IN(NDT)</sub>			75	mV
I <sub>DISCH</sub>	Internal discharge current at AC and USB input	Activated based on settings in CHGCONFIG3 Bit 0 and Bit 7		95		μA

## Electrical Characteristics - Power Path (continued)

PARAMETER		TEST CONDITIONS	MIN	TYP	MAX	UNIT
T <sub>DGL(DT)</sub>	Power detected deglitch	AC or USB voltage increasing		22.5		ms
V <sub>IN(OVP)</sub>	Input over voltage detection threshold		5.8	6	6.3	V
<b>POWER PATH TIMING</b>						
T <sub>SW(ACBAT)</sub>	Switching from AC to BAT	No USB, AC power removed			200	μs
S <sub>W(USBAT)</sub>	T Switching from USB to BAT	No AC, USB power removed			200	μs
T <sub>SW(PSEL)</sub>	Switching from USB to AC	I2C			150	μs
T <sub>SW(ACUSB)</sub>	Switching from AC/ USB, USB / AC	AC power removed or USB power removed			200	μs
T <sub>SYSOK</sub>	SYS power up delay	Measured from power applied to start of power-up sequence		11		ms
<b>POWER PATH INTEGRATED MOSFETS CHARACTERISTICS</b>						
	AC Input switch dropout voltage	(ILIMIT <sub>AC</sub> set = 2.5 A I(SYS) = 1 A)		150		mV
	USB input switch dropout voltage	ILIMIT <sub>USB</sub> = 1300 mA I(SYS) = 500 mA ILIMIT <sub>USB</sub> = 1300 mA I(SYS) = 800 mA		100 160		mV
	Battery switch dropout voltage	V(BAT) = 3.0 V, I(BAT) = 1 A		85	100	mV
<b>INPUT CURRENT LIMIT</b>						
I <sub>USB100</sub>	Input current limit; USB pin	USB input current [0,0]	90		100	mA
I <sub>USB500</sub>	Input current limit; USB pin	USB input current [0,1] (default)	450		500	mA
I <sub>USB800</sub>	Input current limit; USB pin	USB input current [1,0]	700		800	mA
I <sub>USB1300</sub>	Input current limit; USB pin	USB input current [1,1]	1000		1300	mA
I <sub>AC100</sub>	Input current limit; AC pin	AC input current [0,0]	90		100	mA
I <sub>AC500</sub>	Input current limit; AC pin	AC input current [0,1]	450		500	mA
I <sub>A1300</sub>	Input current limit; AC pin	AC input current [1,0]	1000		1300	mA
I <sub>AC2500</sub>	Input current limit; AC pin	AC input current [1,1] (default)	1900		2500	mA
<b>POWER PATH SUPPLEMENT DETECTION PROTECTION AND RECOVERY FUNCTIONS</b>						
V <sub>BSUP1</sub>	Enter battery supplement mode	AC input current set to 10: 1.3A		$V_{OUT} = V_{BAT} - 45 \text{ mV}$		
V <sub>BSUP2</sub>	Exit battery supplement mode			$V_{OUT} = V_{BAT} - 35 \text{ mV}$		
V <sub>SYS(SC1)</sub>	Sys short-circuit detection threshold, power-on	All power path switches set to OFF if $V_{SYS} < V_{SYS(SC1)}$	1.4	1.8	2	V
	Short circuit detection threshold hysteresis			50		mV
R <sub>FLT(AC)</sub>	Sys Short circuit recovery pullup resistors	Internal resistor connected from AC to SYS; Specified by design		500		Ω
R <sub>FLT(USB)</sub>	Sys Short circuit recovery pullup resistors	Internal resistor connected from USB to SYS; Specified by design		500		Ω
V <sub>SYS(SC2)</sub>	Output short-circuit detection threshold, supplement mode $V_{BAT} - V_{SYS} > V_{O(SC2)}$ indicates short-circuit		200	250	300	mV
t <sub>DGL(SC2)</sub>	Deglitch time, supplement mode short circuit			120		μs
t <sub>REC(SC2)</sub>	Recovery time, supplement mode short circuit			60		ms
V <sub>BAT(SC)</sub>	BAT pin short-circuit detection threshold		1.4	1.8	2	V
I <sub>BAT(SC)</sub>	Source current for BAT pin short-circuit detection		4	7.5	11	mA
<b>DPPM LOOP<sup>(1)</sup></b>						
V <sub>DPM</sub>	Threshold at which DPPM loop is enabled. This is the approximate voltage at SYS pin, when the USB or AC switch reaches current limit and the charging current is reduced; Selectable by I2C	Set with Bits <PowerPath DPPM threshold1>; <PowerPath DPPM threshold0>		3.5 3.75 4.25 4.50		V

(1) If the DPPM threshold is lower than the battery voltage, supplement mode will be engaged first and the SYS voltage will chatter around the battery voltage; during that condition no DPPM mode is available.

## 8.15 Electrical Characteristics - Battery Charger

PARAMETER		TEST CONDITIONS	MIN	TYP	MAX	UNIT
<b>CHARGER SECTION</b>						
	Battery discharge current				2	A
V <sub>O(BATREG)</sub>	Battery charger voltage	Depending on setting in CHGCONFIG2 And internal EEPROM Default = 4.20 V (except TPS650721) Default = 4.10 V (for TPS650721)	-1%	4.10	1%	V
			-1%	4.15	1%	
			-1%	4.20	1%	
			-1%	4.25	1%	
V <sub>LOWV</sub>	Precharge to fast-charge transition threshold	default = 2.9 V set with Bit <Precharge Voltage>		2.9 2.5		V
t <sub>DGL1(LOWV)</sub>	Deglintch time on precharge to fast-charge transition			25		ms
t <sub>DGL2(LOWV)</sub>	Deglintch time on fast-charge to precharge transition			25		ms
I <sub>CHG</sub>	Battery fast charge current range	V <sub>BAT(REG)</sub> > V <sub>BAT</sub> > V <sub>LOWV</sub> , V <sub>IN</sub> = V <sub>AC</sub> OR V <sub>USB</sub> = 5 V	100		1500	mA
I <sub>CHG</sub>	Battery fast charge current	V <sub>BAT</sub> > V <sub>LOWV</sub> , V <sub>IN</sub> = 5 V, I <sub>IN-MAX</sub> > I <sub>CHG</sub> , no load on SYS pin, thermal loop not active, DPPM loop not active		K <sub>SET</sub> /R <sub>SET</sub>		A
K <sub>SET</sub>	Fast charge current factor	for a charge current of 1500 mA	820	950	1080	AΩ
K <sub>SET</sub>	Fast charge current factor	for a charge current of 100 mA	890	1050	1200	AΩ
I <sub>PRECHG</sub>	Precharge current		0.06x I <sub>CHG</sub>	0.1x I <sub>CHG</sub>	0.14x I <sub>CHG</sub>	A
I <sub>TERM</sub>	Charge current value for termination detection threshold (internally set)		0.08x I <sub>CHG</sub>	0.1x I <sub>CHG</sub>	0.13x I <sub>CHG</sub>	A
t <sub>DGL(TERM)</sub>	Deglintch time, termination detected			25		ms
V <sub>RCH</sub>	Recharge detection threshold	Voltage below nominal charger voltage	150	100	65	mV
t <sub>DGL(RCH)</sub>	Deglintch time, recharge threshold detected			125		ms
t <sub>DGL(NO-IN)</sub>	Delay time, input power loss to charger turn-off	V <sub>BAT</sub> = 3.6V. Time measured from VIN: 5V → 3.3V 1μs fall-time		20		ms
I <sub>BAT(DET)</sub>	Sink current for battery detection		3		10	mA
t <sub>DET</sub>	Battery detection timer			250		ms
T <sub>CHG</sub>	Charge safety timer	Safety timer range, thermal and DPM not active selectable by I2C with Bits <ChargeSafetyTimerValue1> <ChargeSafetyTimerValue0>	-15%	4 5 6 8	15%	h
T <sub>PRECHG</sub>	Precharge timer	Pre charge timer range, thermal and DPM/DPPM loops not active scalable with <Precharge Time>	25 50	30 60	35 70	min
T <sub>PCHGADD</sub>	Precharge safety timer "add-on" time range	Maximum value for precharge safety timer, thermal, DPM or DPPM loops always active	0		2xT <sub>CHG</sub>	h
<b>BATTERY-PACK NTC MONITOR</b>						
R <sub>T1</sub>	Pullup resistor from thermistor to Internal LDO . I2C selectable	10 k curve 2 NTC	-2%	7.35	2%	kΩ
		100 k curve 1 NTC	-2%	62.5	2%	kΩ
V <sub>HOT</sub>	High temperature trip point (set to 45°C)	Battery charging		860		mV
V <sub>HYS(HOT)</sub>	Hysteresis on high trip point (set to 3°C)	Battery charging		50		mV
V <sub>COLD</sub>	Low temperature trip point (set to 0°C)	Battery charging		1660		mV
V <sub>HYS(COLD)</sub>	Hysteresis on low trip point (set to 3°C)	Battery charging		50		mV
V <sub>noNTC</sub>	No NTC detected	NTC error		2000		mV
T <sub>H<sub>RMDLY</sub></sub>	Deglintch time for thermistor detection after thermistor power on		3			ms
t <sub>DGL(TS)</sub>	Deglintch time, pack temperature fault detection	Battery charging		50		ms
<b>THERMAL REGULATION</b>						
T <sub>J(REG)</sub>	Temperature regulation limit	If temperature is exceeded, charge current is reduced	115	125	135	°C
T <sub>J(OFF)</sub>	Charger thermal shutdown			155		°C
T <sub>J(OFF-HYS)</sub>	Charger thermal shutdown hysteresis			20		°C

## 8.16 Timing Requirements<sup>(1)</sup>

		MIN	MAX	UNIT
$f_{MAX}$	Clock frequency		400	kHz
$t_{WH(HIGH)}$	Clock high time	600		ns
$t_{WL(LOW)}$	Clock low time	1300		ns
$t_R$	SDAT and CLK rise time		300	ns
$t_F$	SDAT and CLK fall time		300	ns
$t_h(STA)$	Hold time (repeated) START condition (after this period the first clock pulse is generated)	600		ns
$t_{su(STA)}$	Setup time for repeated START condition	600		ns
$t_h(SDAT)$	Data input hold time	0		ns
$t_{su(SDAT)}$	Data input setup time	100		ns
$t_{su(STO)}$	STOP condition setup time	600		ns
$t_{BUF}$	Bus free time	1300		ns

(1) Note: Rise and fall time  $t_r$  and  $t_f$  for the SDAT and CLK signals are defined for 10% to 90% of  $V(INT-LDO)$  which is 2.2 V

## 8.17 Dissipation Ratings<sup>(1)</sup>

PACKAGE	$R_{\theta JA}$	$T_A = 25^\circ C$ POWER RATING	DERATING FACTOR ABOVE $T_A = 25^\circ C$	$T_A = 70^\circ C$ POWER RATING	$T_A = 85^\circ C$ POWER RATING
RSL	37 K/W	2.6 W	26 mW/K	1.48 W	1 W

(1) The thermal resistance  $R_{\theta JP}$  junction to thermal pad of the RSL package is 1.1 K/W. The value for  $R_{\theta JA}$  was measured on a high K board.

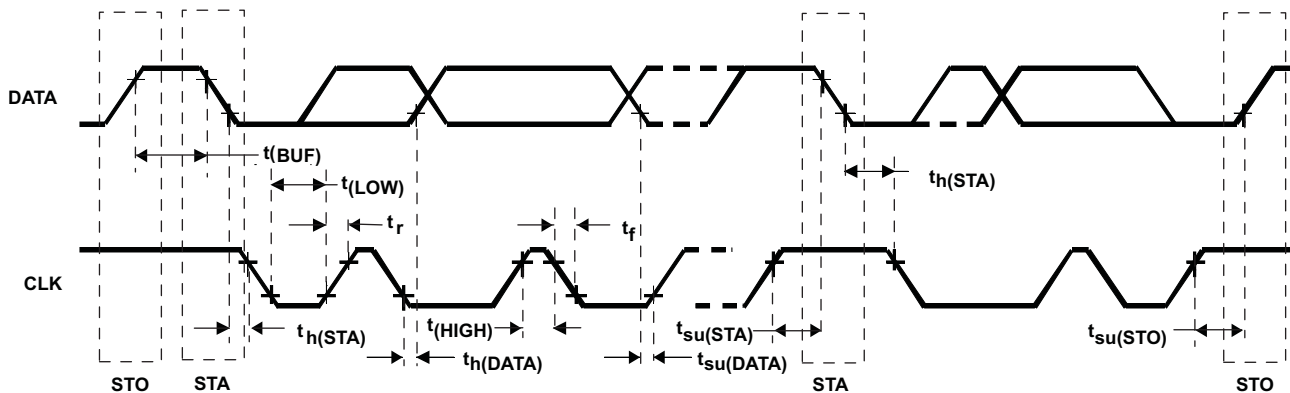

Figure 1. Serial Interface Timing Diagram

## 8.18 Typical Characteristics

Table 1. Table of Graphs

		FIGURE
Efficiency DCDC1 vs Load current / PWM mode	$V_O = 3.3\text{ V}; V_I = 3\text{ V}, 3.6\text{ V}, 4.2\text{ V}, 5\text{ V}$	Figure 2
Efficiency DCDC1 vs Load current / PFM mode	$V_O = 3.3\text{ V}; V_I = 3\text{ V}, 3.6\text{ V}, 4.2\text{ V}, 5\text{ V}$	Figure 3
Efficiency DCDC2 vs Load current / PWM mode up to 1.5A	$V_O = 2.5\text{ V}; V_I = 3\text{ V}, 3.6\text{ V}, 4.2\text{ V}, 5\text{ V}$	Figure 4
Efficiency DCDC2 vs Load current / PFM mode up to 1.5A	$V_O = 2.5\text{ V}; V_I = 3\text{ V}, 3.6\text{ V}, 4.2\text{ V}, 5\text{ V}$	Figure 5
Efficiency DCDC2 vs Load current / PWM mode up to 1.5A	$V_O = 1.8\text{ V}; V_I = 3\text{ V}, 3.6\text{ V}, 4.2\text{ V}, 5\text{ V}$	Figure 6
Efficiency DCDC2 vs Load current / PFM mode up to 1.5A	$V_O = 1.8\text{ V}; V_I = 3\text{ V}, 3.6\text{ V}, 4.2\text{ V}, 5\text{ V}$	Figure 7
Efficiency DCDC3 vs Load current / PWM mode up to 1.5A	$V_O = 1.2\text{ V}; V_I = 3\text{ V}, 3.6\text{ V}, 4.2\text{ V}, 5\text{ V}$	Figure 8
Efficiency DCDC3 vs Load current / PFM mode up to 1.5A	$V_O = 1.2\text{ V}; V_I = 3\text{ V}, 3.6\text{ V}, 4.2\text{ V}, 5\text{ V}$	Figure 9
Efficiency DCDC3 vs Load current / PWM mode up to 1.5A	$V_O = 1\text{ V}; V_I = 3\text{ V}, 3.6\text{ V}, 4.2\text{ V}, 5\text{ V}$	Figure 10
Efficiency DCDC3 vs Load current / PFM mode up to 1.5A	$V_O = 1\text{ V}; V_I = 3\text{ V}, 3.6\text{ V}, 4.2\text{ V}, 5\text{ V}$	Figure 11
Load transient response converter 1	Scope plot; $I_O = 60\text{ mA}$ to $540\text{ mA}; V_O = 3.3\text{ V}; V_I = 3.6\text{ V}$	Figure 12
Load transient response converter 2	Scope plot; $I_O = 150\text{ mA}$ to $1350\text{ mA}; V_O = 1.8\text{ V}; V_I = 3.6\text{ V}$	Figure 13
Load transient response converter 3	Scope plot; $I_O = 150\text{ mA}$ to $1350\text{ mA}; V_O = 1.2\text{ V}; V_I = 3.6\text{ V}$	Figure 14
Line transient response converter 1	Scope plot; $V_O = 3.3; V_I = 3.6\text{ V}$ to $5\text{ V}$ to $3.6\text{ V}; I_O = 600\text{ mA}$	Figure 15
Line transient response converter 2	Scope plot; $V_O = 1.8; V_I = 3.6\text{ V}$ to $5\text{ V}$ to $3.6\text{ V}; I_O = 600\text{ mA}$	Figure 16
Line transient response converter 3	Scope plot; $V_O = 1.2\text{ V}; V_I = 3.6\text{ V}$ to $5\text{ V}$ to $3.6\text{ V}; I_O = 600\text{ mA}$	Figure 17
Output voltage ripple and inductor current converter 2; PWM Mode	Scope plot; $V_I = 3.6\text{ V}; V_O = 1.8\text{ V}; I_O = 10\text{ mA}$	Figure 18
Output voltage ripple and inductor current converter 2; PFM Mode	Scope plot; $V_I = 3.6\text{ V}; V_O = 1.8\text{ V}; I_O = 10\text{ mA}$	Figure 19
Startup DCDC1, DCDC2 and DCDC3, LDO1, LDO2	Scope plot	Figure 20
Load transient response LDO1	Scope plot; $V_O = 1.2\text{ V}; V_I = 3.6\text{ V}$	Figure 21
Line transient response LDO1	Scope plot	Figure 22
$K_{SET}$ vs $R_{ISET}$		Figure 23
wLED efficiency vs duty cycle	2 x 6LEDs ( $V_{LED} = 19.2\text{ V}$ ); $I_O = 2 \times 20\text{ mA}$	Figure 24
wLED efficiency vs input voltage	2 x 6LEDs ( $V_{LED} = 19.2\text{ V}$ ); $I_O = 2 \times 20\text{ mA}$	Figure 25

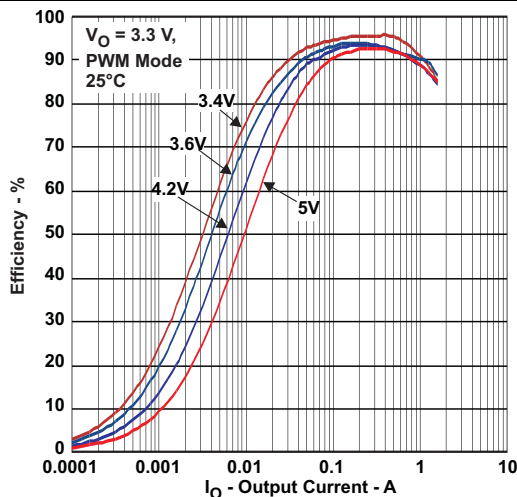

Figure 2. Efficiency DCDC1 vs Load Current/PWM Mode

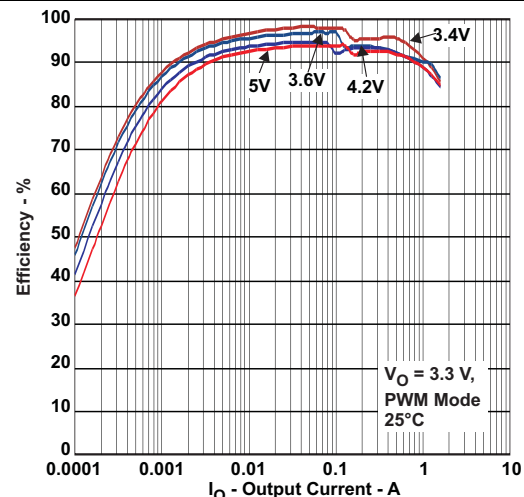

Figure 3. Efficiency DCDC1 vs Load Current/PFM Mode

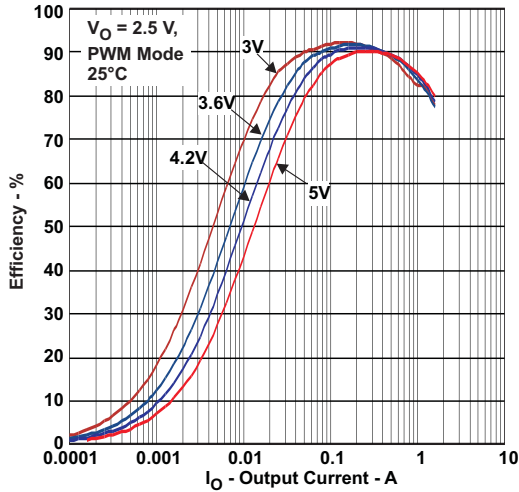

Figure 4. Efficiency DCDC2 vs Load Current/PWM Mode

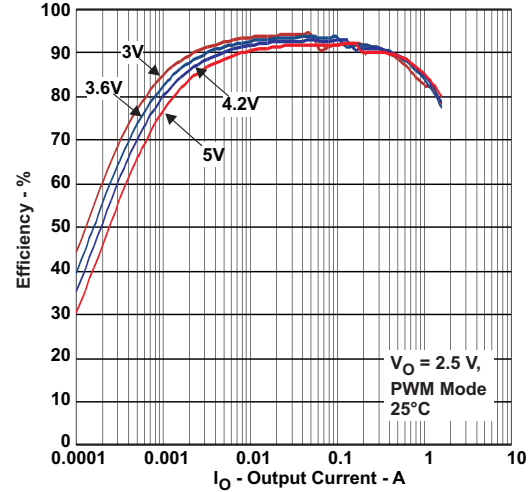

Figure 5. Efficiency DCDC2 vs Load Current/PFM Mode

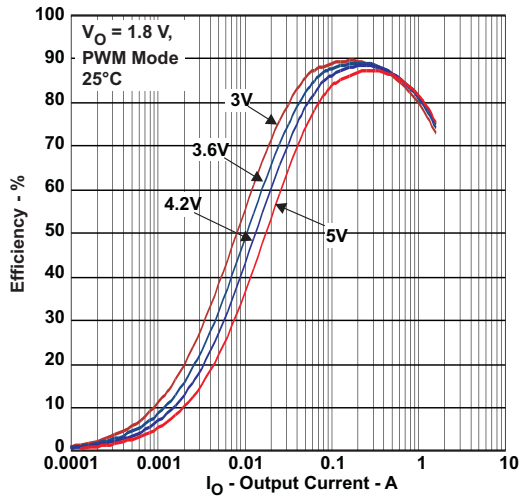

Figure 6. Efficiency DCDC2 vs Load Current/PWM Mode

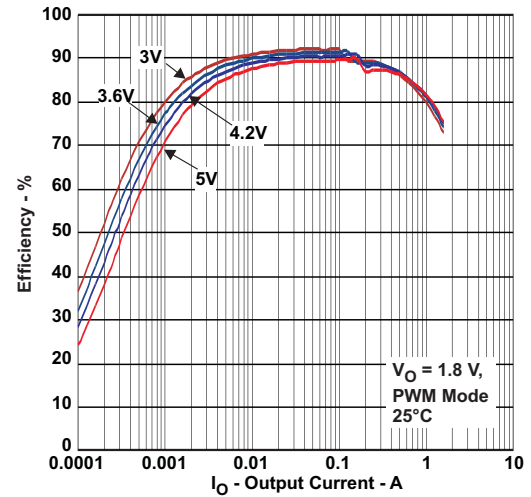

Figure 7. Efficiency DCDC2 vs Load Current/PFM Mode

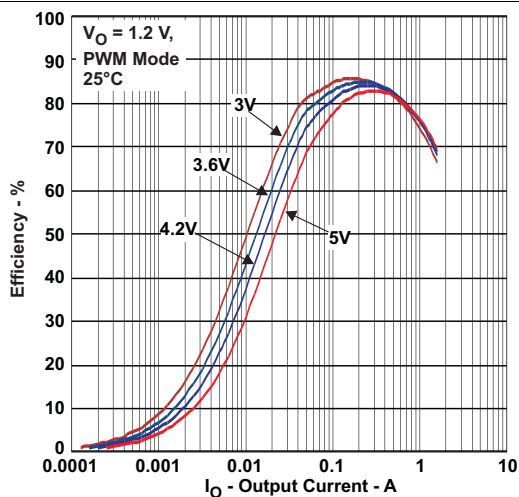

Figure 8. Efficiency DCDC3 vs Load Current/PWM Mode

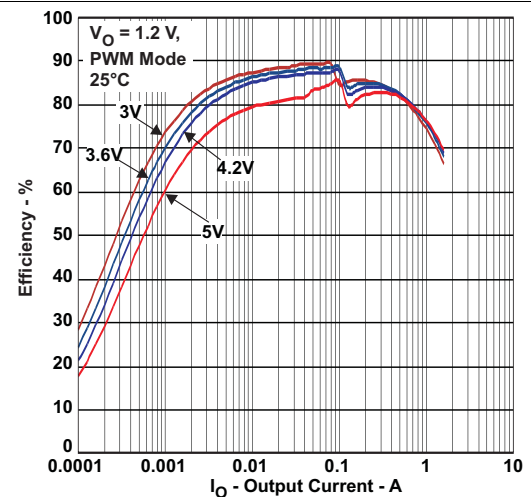

Figure 9. Efficiency DCDC3 vs Load Current/PFM Mode

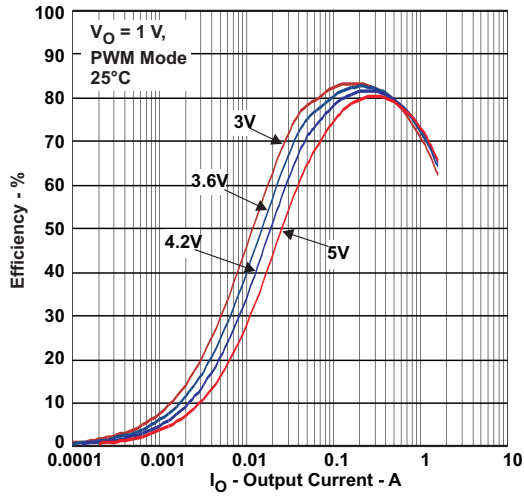

Figure 10. Efficiency DCDC3 vs Load Current/PWM Mode

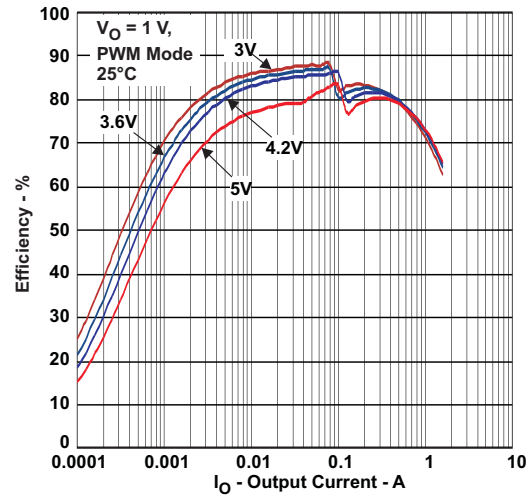

Figure 11. Efficiency DCDC3 vs Load Current/PFM Mode

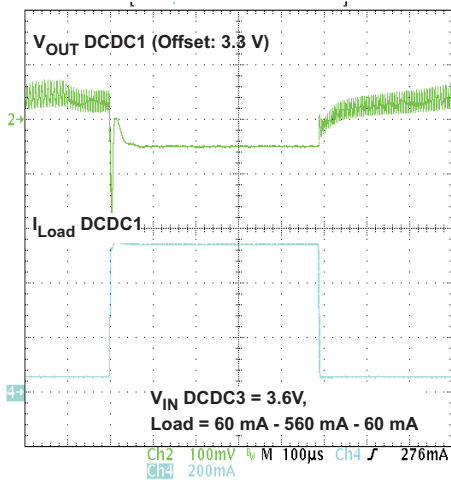

Figure 12. Load Transient Response Converter 1

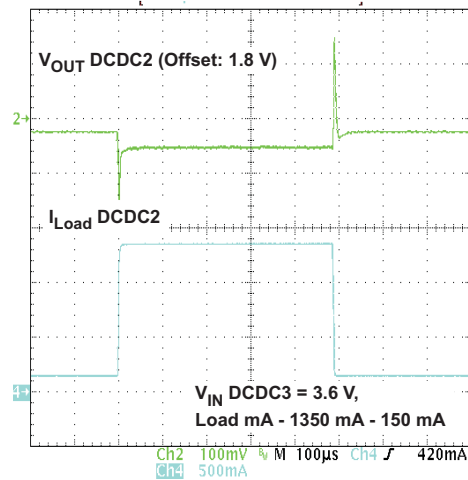

Figure 13. Load Transient Response Converter 2

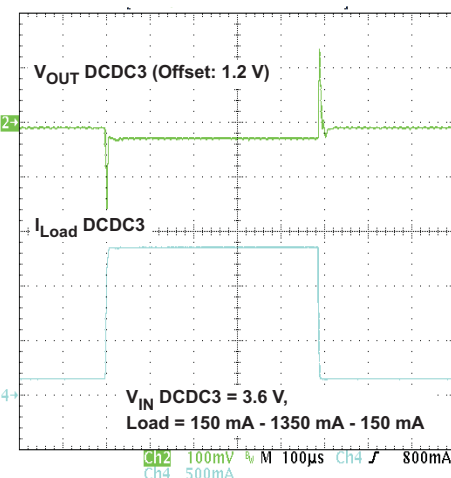

Figure 14. Load Transient Response Converter 3

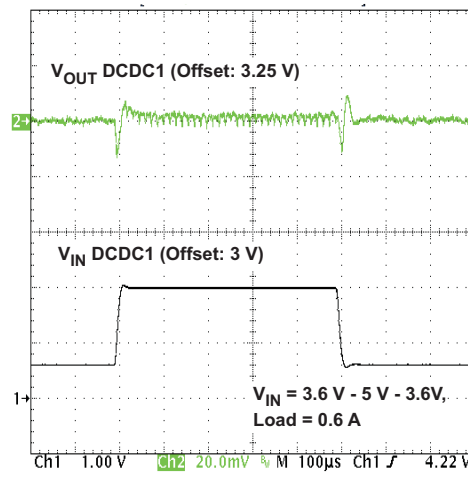

Figure 15. Line Transient Response Converter 1

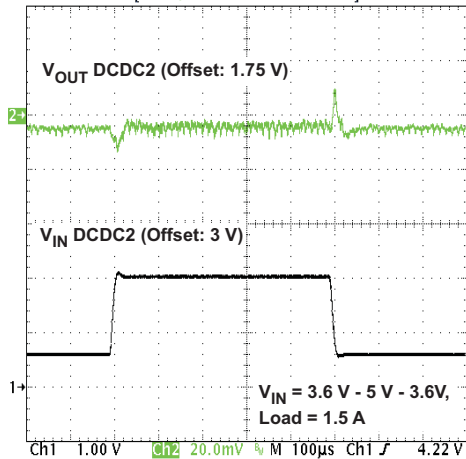

Figure 16. Line Transient Response Converter 2

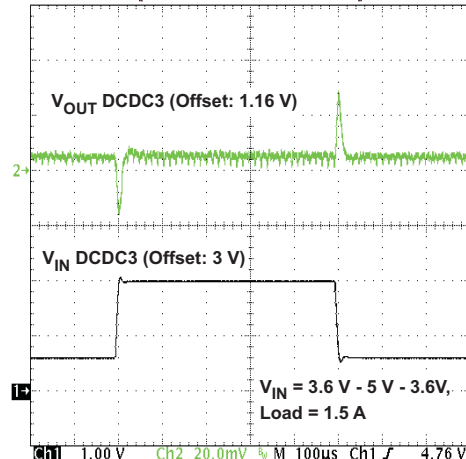

Figure 17. Line Transient Response Converter 3

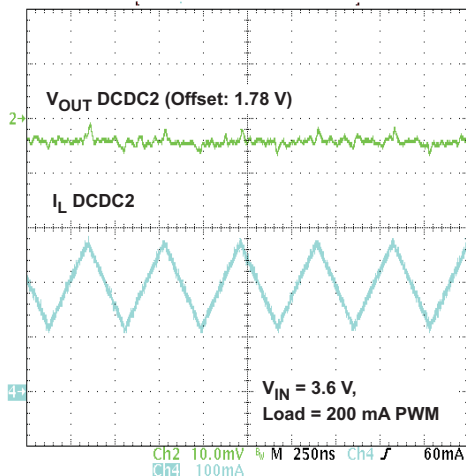

Figure 18. Output Voltage Ripple and Inductor Current Converter 2 – PWM Mode

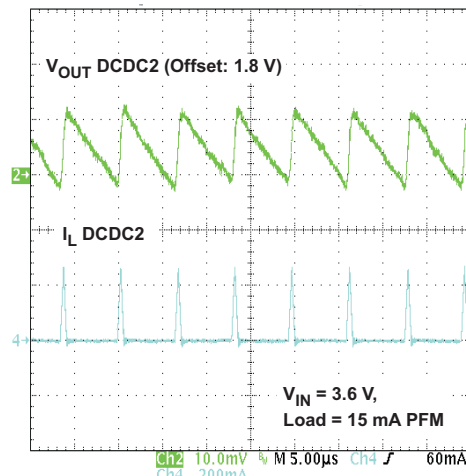

Figure 19. Output Voltage Ripple and Inductor Current Converter 2 – PFM Mode

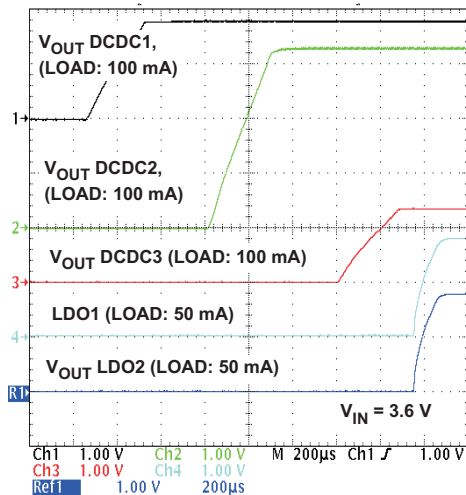

Figure 20. Startup DCDC1, DCDC2, AND DCDC3, LDO1, LDO2

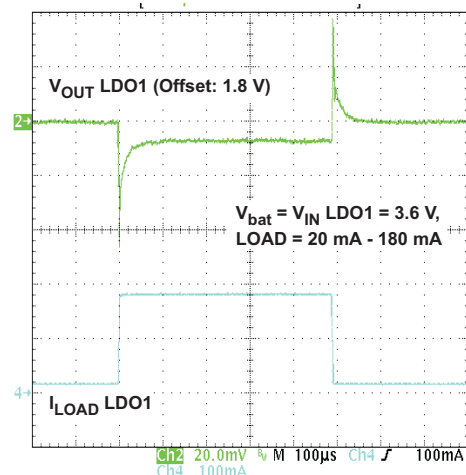

Figure 21. Load Transient Response LDO1

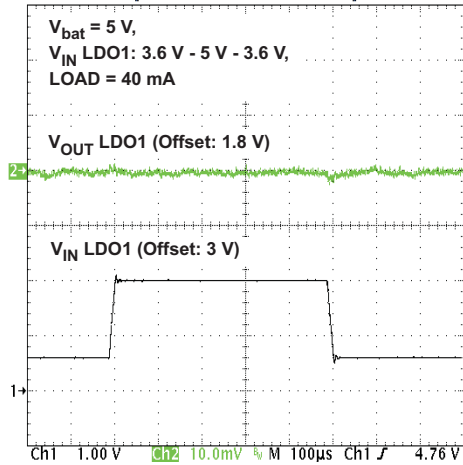

Figure 22. Line Transient Response LDO1

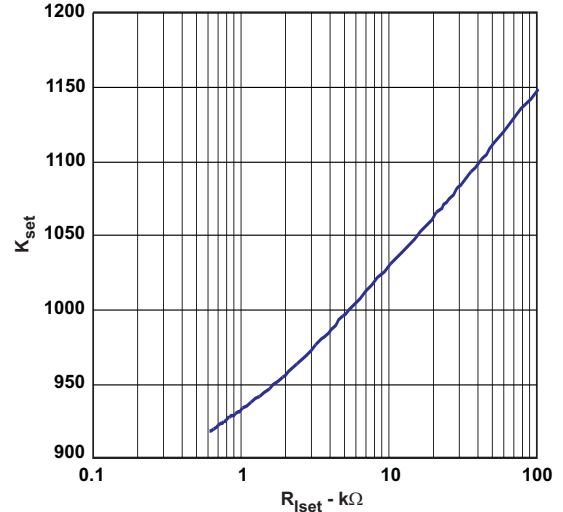

Figure 23.  $K_{SET}$  vs  $R_{ISET}$

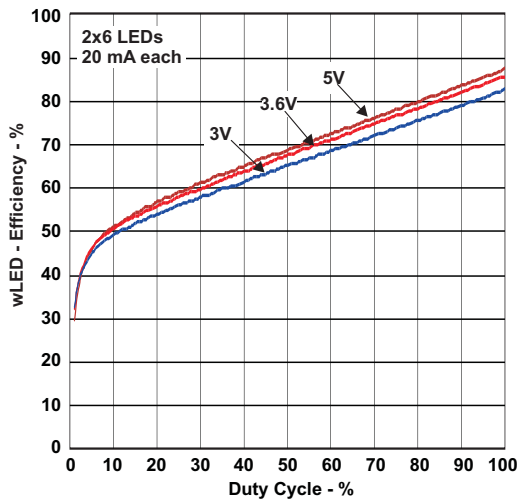

Figure 24. wLED Efficiency vs Duty Cycle

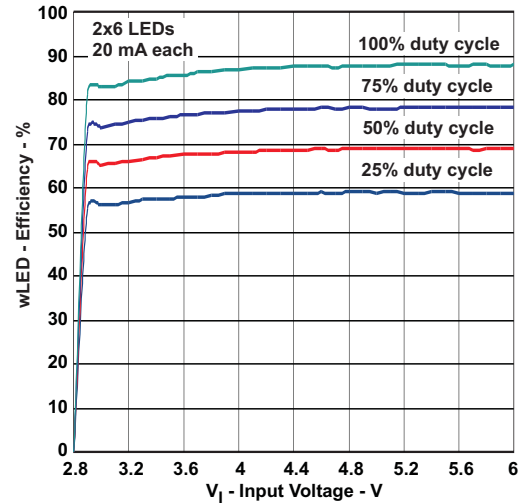

Figure 25. wLED Efficiency vs  $V_{in}$

## 9 Parameter Measurement Information

The data sheet graphs were taken on the TPS6507x evaluation module (EVM). Refer to the [TPS6507xEVM user's guide](#) for the setup information.

## 10 Detailed Description

### 10.1 Overview

This section provides a description of each of the individual block that are featured in the TPS6507x device. The device is great for a variety of applications for it has a configurable battery charger, 3 DC-DC step-down converters, 2 LDOs, and 2 string wLED boost and sink control. In addition to the digital logic power goods and interrupts of the device, the device has a 4-channel ADC or touch screen interface. The device has I<sup>2</sup>C and hardware enable pin controls for a flexible PMU interface.

### 10.2 Functional Block Diagram

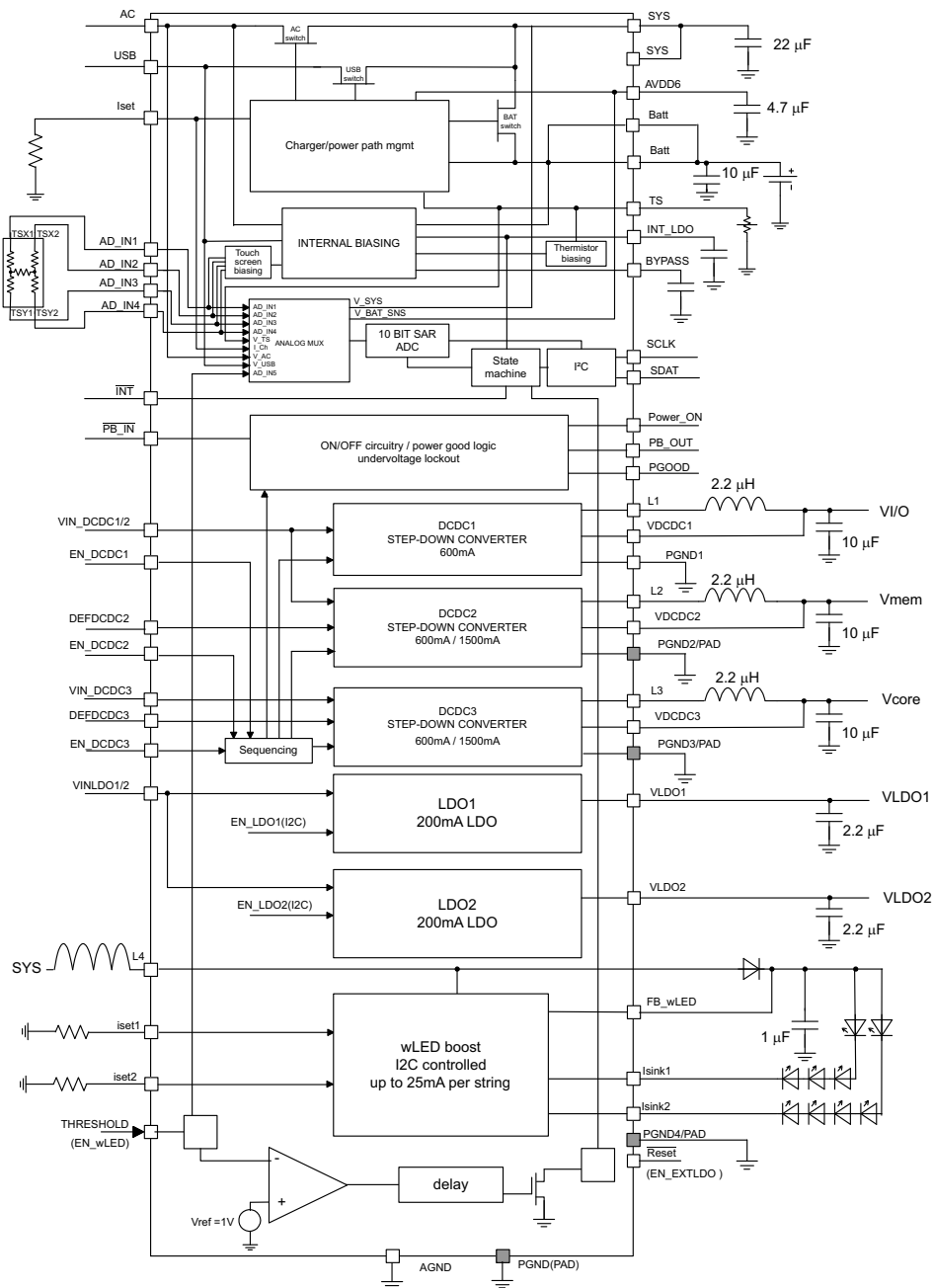

Copyright © 2016, Texas Instruments Incorporated

### 10.3 Feature Description

#### 10.3.1 Battery Charger and Power Path

The TPS6507x integrates a Li-ion linear charger and system power path management targeted at space-limited portable applications. The TPS6507x power the system while simultaneously and independently charging the battery. This feature reduces the number of charge and discharge cycles on the battery, allows for proper charge termination and enables the system to run with a defective or absent battery pack. It also allows instant system turn-on even with a totally discharged battery. The input power source for charging the battery and running the system can be an AC adapter or an USB port. The power-path management feature automatically reduces the charging current if the system load increases. The power-path architecture also permits the battery to supplement the system current requirements when the adapter cannot deliver the peak system currents.

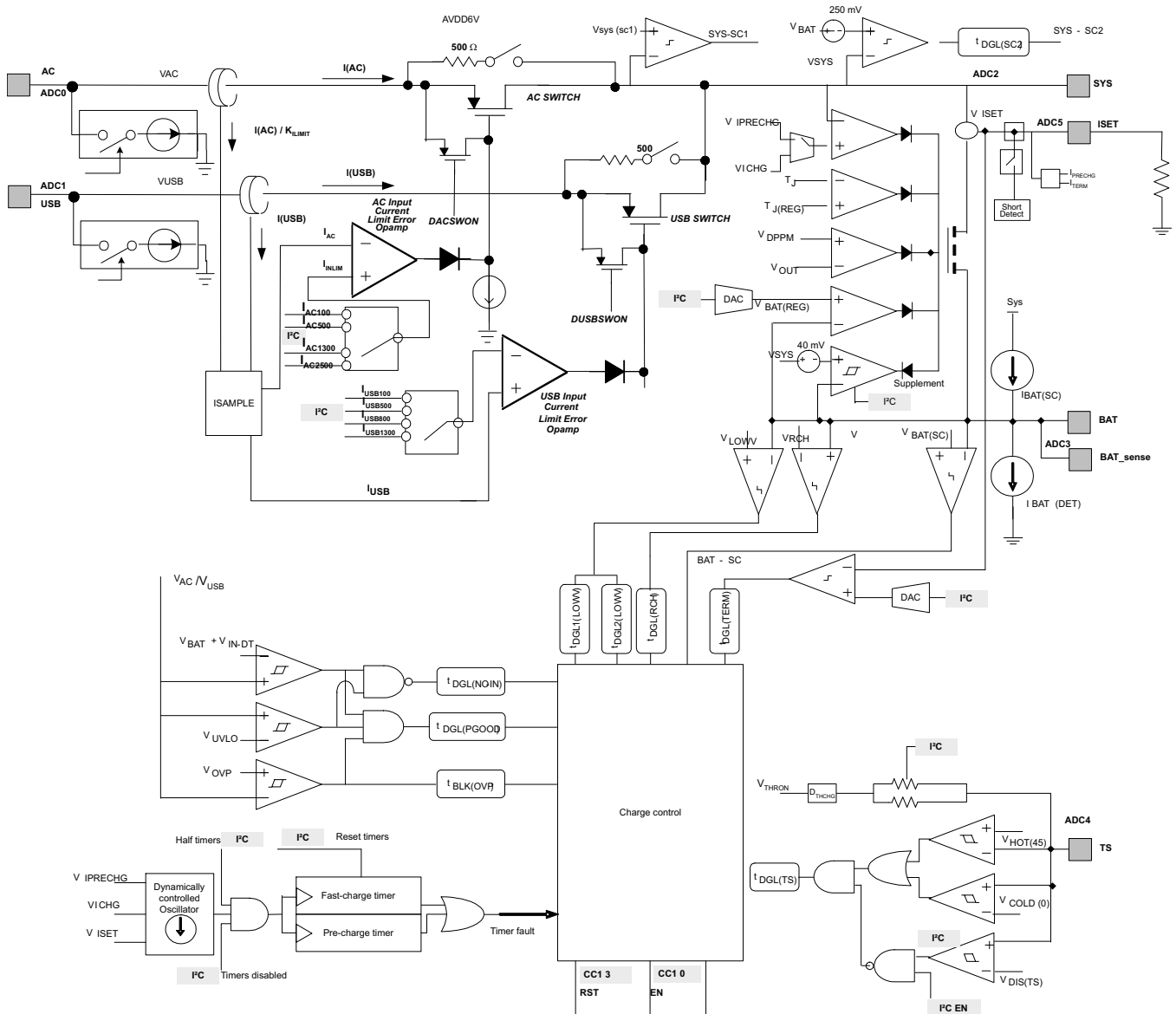

Copyright © 2016, Texas Instruments Incorporated

Figure 26. Charger Block Diagram

## Feature Description (continued)

### 10.3.2 Power Down

The charger remains in a power down mode when the input voltage at the AC or USB pin is below the under-voltage lockout threshold  $V_{UVLO}$ . During the power down mode the host commands at the control pins are not interpreted.

### 10.3.3 Power-On Reset

The charger resets when the input voltage at the AC or USB pin enters the valid range between  $V_{UVLO}$  and  $V_{OVLO}$ . All internal timers and other circuit blocks are reset. The device then waits for a time period  $T_{DGL(PGOOD)}$ , after which CHARGER ACTIVE Bit indicates the input power status, and the Iset pin is interpreted.

### 10.3.4 Power-Path Management

There are two inputs to the power path called AC and USB. Both inputs support the same voltage rating but are typically set to a different current limit with AC being at the higher limit and USB at the lower. If voltage is applied at both inputs and both are enabled in register PPATH1 (default setting), AC will be preferred over USB. In this case, the device is only powered from AC and there is no current from USB. If voltage at AC is removed, the USB input will become and TPS6507x is powered from USB. The current at the input pin AC or USB of the power path manager is shared between charging the battery and powering the system load on the SYS pin. Priority is given to the system load. The input current is monitored continuously. If the sum of the charging and system load currents exceeds the preset maximum input current (programmed internally by I2C), the charging current is reduced automatically. See the electrical characteristics or the register description for the default current limit on AC and USB for the different family members.

Figure 27 illustrates what happens in an example case where the battery fast-charge current is set to 500 mA, the input current limit is set at 900 mA and the system load varies from 0 to 750 mA.

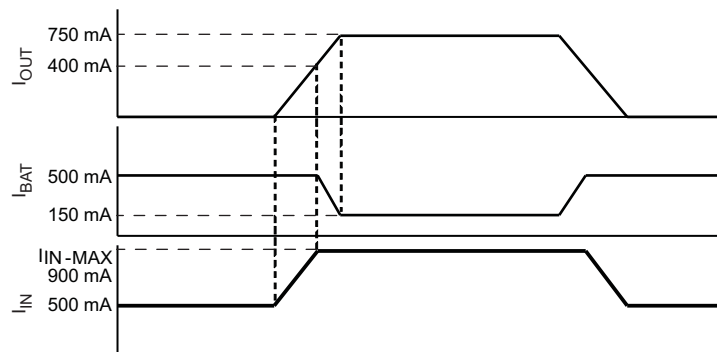

Figure 27. Power Path Functionality

#### 10.3.4.1 SYS Output

The SYS pin is the output of the power path. When TPS6507x is turned off and there is no voltage at AC or USB, the SYS output is disconnected internally from the battery. When TPS6507x is turned on by pulling  $PB\_IN = LOW$ , the voltage at SYS will ramp with a soft-start. During soft start, the voltage at SYS is ramped with a 30-mA current source until the voltage reached 1.8 V. During the soft start, the SYS pin must not be loaded by an external load.

### 10.3.5 Battery Charging

When Bit CHARGER ENABLE in register CHGCONFIG1 is set to 1, battery charging can begin. First, the device checks for a short-circuit on the BAT pin:  $I_{BAT(SC)}$  is turned on till the voltage on the BAT pin rises above  $V_{BAT(SC)}$ . If conditions are safe, it proceeds to charge the battery.

The battery is charged in three phases: conditioning precharge, constant current fast charge (current regulation) and a constant voltage tapering-off (voltage regulation). In all charge phases, an internal control loop monitors the IC junction temperature and reduces the charge current if the internal temperature threshold is exceeded.

Figure 28 shows what happens in each of the three phases.

## Feature Description (continued)

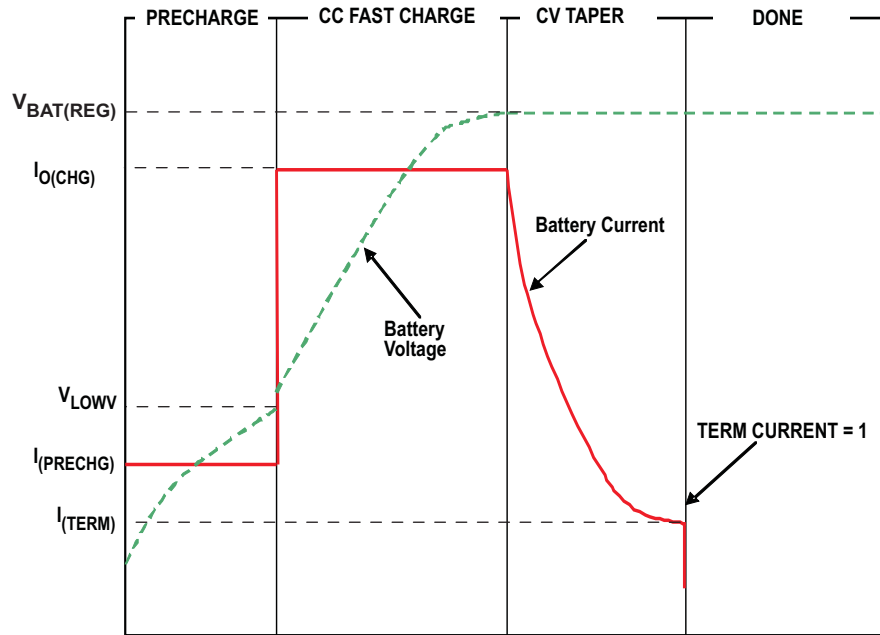

Figure 28. Battery Charge

In the precharge phase, the battery is charged at a current of  $I_{PRECHG}$ . The battery voltage starts rising. Once the battery voltage crosses the  $V_{LOWV}$  threshold, the battery is charged at a current of  $I_{CHG}$ . The battery voltage continues to rise. When the battery voltage reaches  $V_{BAT(REG)}$ , the battery is held at a constant value of  $V_{BAT(REG)}$ . The battery current now decreases as the battery approaches full charge. When the battery current reaches  $I_{TERM}$ , the TERM CURRENT flag in register CHGCONFIG0 indicates charging done by going high.

Note that termination detection is disabled whenever the charge rate is reduced from the set point because of the actions of the thermal loop, the DPM loop or the  $V_{IN-LOW}$  loop.

The value of the fast-charge current is set by the resistor connected from the ISET pin to GND, and is given by the equation

$$I_{CHG} = K_{ISET} / R_{ISET} \quad (1)$$

$$R_{ISET} = K_{ISET} / I_{CHG} \quad (2)$$

Note that if  $I_{CHG}$  is programmed as greater than the input current limit, the battery will not charge at the rate of  $I_{CHG}$ , but at the slower rate of  $I_{IN-MAX}$  (minus the load current on the OUT pin, if any). In this case, the charger timers will be slowed down by 2x whenever the thermal loop or DPPM is active.

### 10.3.5.1 I-PRECHARGE

The value for the precharge current is fixed to a factor of 0.1 of the fast charge current (full scale current) programmed by the external resistor  $R_{set}$ .

### 10.3.5.2 ITERM

The value for the termination current threshold can be set in register CHGCONFIG3 using Bits TERMINATION CURRENT FACTOR 0 and TERMINATION CURRENT FACTOR 1. The termination current is pre-set to a factor of 0.1 of the fast charge current programmed by the external resistor  $R_{set}$ .

### 10.3.5.3 Battery Detection and Recharge

Whenever the battery voltage falls below  $V_{RCH}$  ( $V_{set}-100$  mV), a check is performed to see whether the battery has been removed: current  $I_{BAT(DET)}$  is pulled from the battery for a duration  $t_{DET}$ . If the voltage on the BAT pin remains above  $V_{LOWV}$ , it indicates that the battery is still connected. If the charger is enabled by Bit CHARGER ENABLE in register CHGCONFIG1 set to 1, the charger is turned on again to top up the battery.

## Feature Description (continued)

If the BAT pin voltage falls below  $V_{LOWV}$  in the battery detection test, it indicates that the battery has been removed. The device then checks for battery insertion: it turns on FET Q2 and sources  $I_{PRECHG}$  out of the BAT pin for duration  $t_{DET}$ . If the voltage does not rise above  $V_{RCH}$ , it indicates that a battery has been inserted, and a new charge cycle can begin. If, however, the voltage does rise above  $V_{RCH}$ , it is possible that a fully charged battery has been inserted. To check for this,  $I_{BAT(DET)}$  is pulled from the battery for  $t_{DET}$ : if the voltage falls below  $V_{LOWV}$ , a battery is not present. The device keeps looking for the presence of a battery.

### 10.3.5.4 Charge Termination On/Off

Charge termination can be disabled by setting the Bit CHARGE TERMINATION ON/OFF in register CHGCONFIG1 to logic high. When termination is disabled, the device goes through the precharge, fast-charge and CV phases, then remains in the CV phase – the charger behaves like an LDO with an output voltage equal to  $V_{BAT(REG)}$ , able to source current up to  $I_{CHG}$  or  $I_{IN-MAX}$ , whichever is lesser. Battery detection is not performed.

### 10.3.5.5 Timers

The charger in TPS6507x has internal safety timers for the precharge and fast-charge phases to prevent potential damage to either the battery or the system. The default values for the timers can be changed in registers CHGCONFIG1 and CHGCONFIG3. The timers can be disabled by clearing Bit SAFETY TIMERS ENABLE in register CHGCONFIG1. (The timers are disabled when termination is disabled: Bit CHARGE TERMINATION ON/OFF in register CHGCONFIG1 =1).

### 10.3.5.6 Dynamic Timer Function

The following events can reduce the charging current and increase the timer durations in the fast charge phase:

- The system load current increases, and the DPPM loop reduces the available charging current
- The input current is reduced because the input voltage has fallen to  $V_{IN-LOW}$
- The device has entered thermal regulation because the IC junction temperature has exceeded  $T_{J(REG)}$

In each of these events, the internal timers are slowed down proportionately to the reduction in charging current. Note also that whenever any of these events occurs, termination detection is disabled.

A modified charge cycle with the thermal loop active is shown in [Figure 29](#).

## Feature Description (continued)

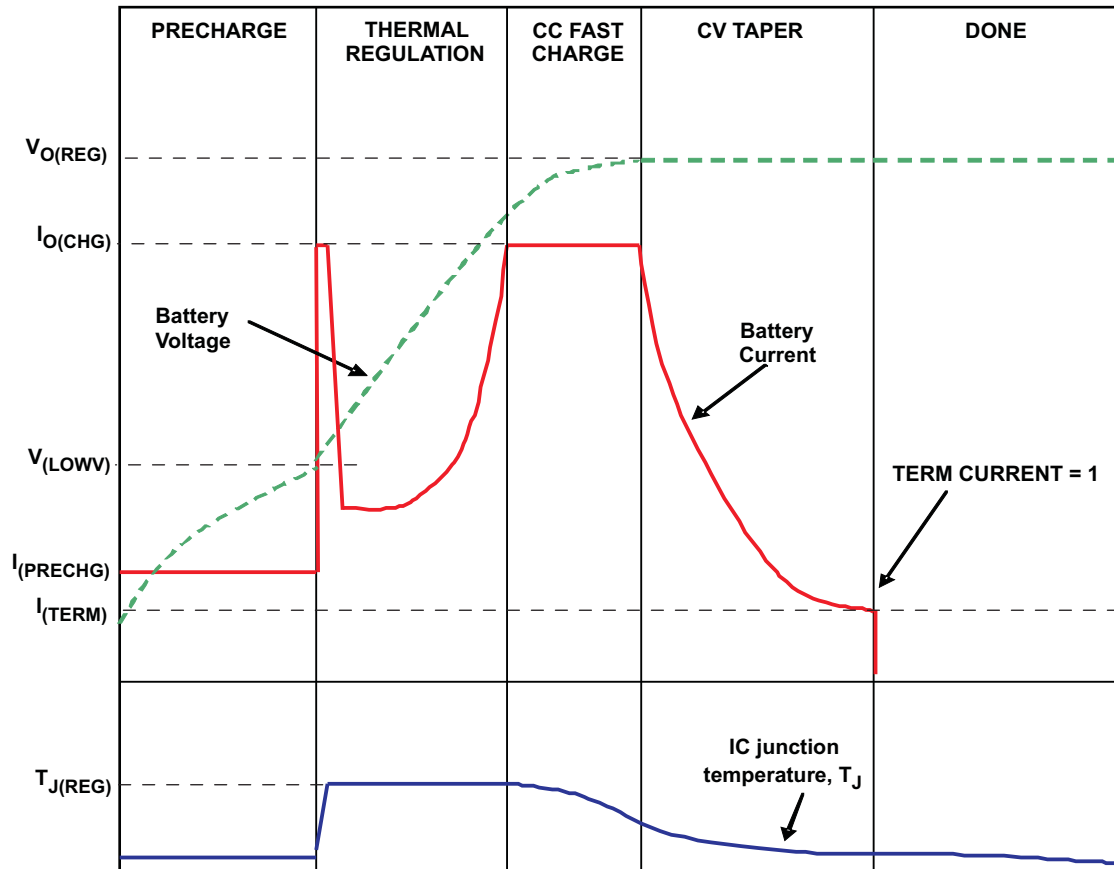

Figure 29. Thermal Loop

### 10.3.5.7 Timer Fault

The following events generate a fault status:

- If the battery voltage does not exceed  $V_{LOWV}$  in time  $t_{PRECHG}$  during precharging
- If the battery current does not reach  $I_{TERM}$  in time  $t_{MAXCH}$  in fast charge (measured from beginning of fast charge).

The fault status is indicated by Bits CHG TIMEOUT or PRECHG TIMEOUT in register CHGCONFIG0 set to 1.

### 10.3.6 Battery Pack Temperature Monitoring

The device has a TS pin that connects to the NTC resistor in the battery pack. During charging, if the resistance of the NTC indicates that the battery is operating outside the limits of safe operation, charging is turned off. All timers maintain their values. When the battery pack temperature returns to a safe value, charging is resumed, and the timers are also turned back on.

Battery pack temperature sensing is disabled when termination is disabled and the voltage on the TS pin is higher than  $V_{DIS(TS)}$  (caused by absence of pack and thus absence of NTC).

The default for the NTC is defined in register CHGCONFIG1 with Bit SENSOR TYPE as a 10k curve 2 NTC. The sensor can be changed to a 100-k $\Omega$  curve 1 NTC by setting the Bit to 0.

There needs to be a resistor in parallel to the NTC for linearization of the temperature curve. The value for the resistor is given in [Table 15](#).

## Feature Description (continued)

### 10.3.7 Battery Charger State Diagram

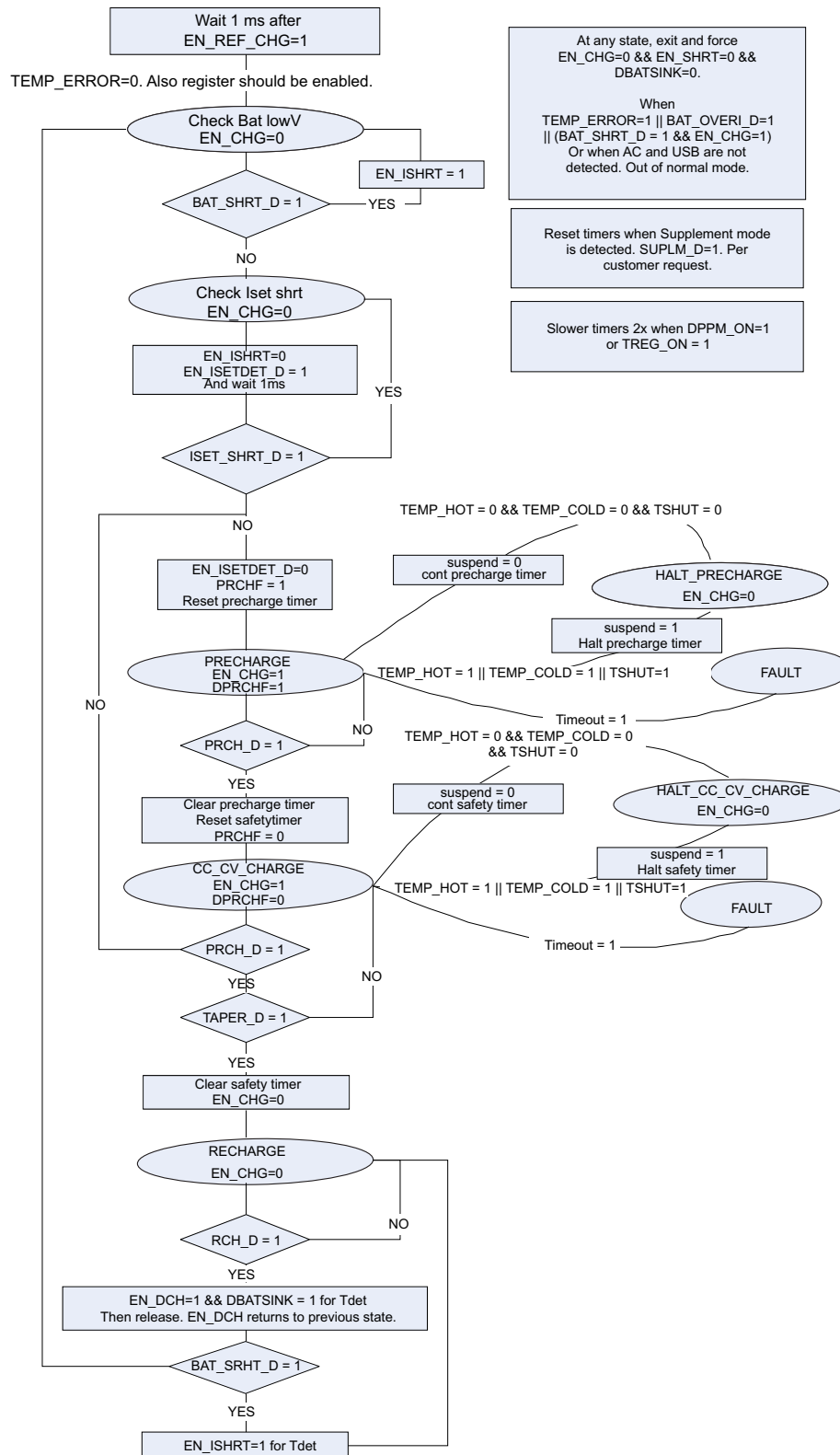

Figure 30. Charger State Machine

## Feature Description (continued)

### 10.3.8 DC-DC Converters and LDOs

#### 10.3.8.1 Operation

The TPS6507x step down converters operate with typically 2.25-MHz fixed-frequency pulse width modulation (PWM) at moderate to heavy load currents. At light load currents the converter automatically enters power save mode and operates in pulse frequency modulation (PFM).

During PWM operation the converter use a unique fast response voltage mode controller scheme with input voltage feed-forward to achieve good line and load regulation allowing the use of small ceramic input and output capacitors. At the beginning of each clock cycle initiated by the clock signal, the high side MOSFET switch is turned on. The current flows now from the input capacitor through the high side MOSFET switch through the inductor to the output capacitor and load. During this phase, the current ramps up until the PWM comparator trips and the control logic will turn off the switch. The current limit comparator will also turn off the switch in case the current limit of the high side MOSFET switch is exceeded. After a dead time preventing shoot through current, the low side MOSFET rectifier is turned on and the inductor current will ramp down. The current flows now from the inductor to the output capacitor and to the load. It returns back to the inductor through the low side MOSFET rectifier.

The next cycle will be initiated by the clock signal again turning off the low side MOSFET rectifier and turning on the on the high side MOSFET switch.

The DC-DC converters operate synchronized to each other, with converter 1 as the master. A phase shift of 180° between converter 1 and converter 2 decreases the input RMS current. Therefore smaller input capacitors can be used. Converter 3 operates in phase with converter 1.

#### 10.3.8.2 DCDC1 Converter

The output voltage for converter 1 is set to a fixed voltage internally in register DEFDCDC1. The voltage can be changed using the I2C interface. The default settings are given in [Table 2](#).

Optionally the voltage can be set by an external resistor divider if configured in register DEFDCDC1.

#### 10.3.8.3 DCDC2 Converter

The VDCDC2 pin must be directly connected to the DCDC2 converter's output voltage. The DCDC2 converter's output voltage can be selected through the DEFDCDC2 pin or optionally by changing the values in registers DEFDCDC2\_LOW and DEFDCDC2\_HIGH. If pin DEFDCDC2 is pulled to GND, register DEFDCDC2\_LOW defines the output voltage. If the pin DEFDCDC2 is driven HIGH, register DEFDCDC2\_HIGH defines the output voltage. Therefore, the voltage can either be changed between two values by toggling pin DEFDCDC2 or by changing the register values. Default voltages for DCDC1, DCDC2 and DCDC3 are:

**Table 2. Default Voltages**

	DCDC1	DCDC2		DCDC3	
		DEFDCDC2=LOW	DEFDCDC2=HIGH	DEFDCDC3=LOW	DEFDCDC3=HIGH
TPS65070	3.3 V	1.8 V	3.3 V	1.0 V	1.2 V
TPS65072	3.3 V	1.8 V	2.5 V	1.2 V	1.4 V
TPS65073	1.8 V	1.2 V	1.8 V	1.2 V	1.35 V
TPS650731	1.8 V	1.2 V	1.8 V	1.2 V	1.35 V
TPS650732	1.8 V	1.8 V	3.3 V	1.2 V	1.35 V

#### 10.3.8.4 DCDC3 Converter

The VDCDC3 pin must be directly connected to the DCDC3 converter's output voltage. The DCDC3 converter's output voltage can be selected through the DEFDCDC3 pin or optionally by changing the values in registers DEFDCDC3\_LOW and DEFDCDC3\_HIGH. If pin DEFDCDC3 is pulled to GND, register DEFDCDC3\_LOW defines the output voltage. If the pin DEFDCDC3 is driven HIGH, register DEFDCDC3\_HIGH defines the output voltage. Therefore, the voltage can either be changed between two values by toggling pin DEFDCDC3 or by changing the register values.

LDO2 can optionally be forced to follow the voltage defined for DCDC3 by setting Bit LDO2 TRACKING in register DEF\_LDO2.

### 10.3.9 Power Save Mode

The power save mode is enabled by default. If the load current decreases, the converter will enter power save mode operation automatically. During power save mode the converter skips switching and operates with reduced frequency in PFM mode and with a minimum quiescent current to maintain high efficiency. The converter will position the output voltage typically +1% above the nominal output voltage. This voltage positioning feature minimizes voltage drops caused by a sudden load step.

The transition from PWM mode to PFM mode occurs once the inductor current in the low side MOSFET switch becomes 0.

During the power save mode the output voltage is monitored with a PFM comparator. As the output voltage falls below the PFM comparator threshold of  $V_{OUTnominal} + 1\%$ , the device starts a PFM pulse. For this the high side MOSFET switch will turn on and the inductor current ramps up. Then it will be turned off and the low side MOSFET switch will be turned on until the inductor current becomes 0.

The converter effectively delivers a current to the output capacitor and the load. If the load is below the delivered current the output voltage will rise. If the output voltage is equal or higher than the PFM comparator threshold, the device stops switching and enters a sleep mode with typical 19- $\mu$ A current consumption.

In case the output voltage is still below the PFM comparator threshold, further PFM current pulses will be generated until the PFM comparator threshold is reached. The converter starts switching again once the output voltage drops below the PFM comparator threshold.

With a single threshold comparator, the output voltage ripple during PFM mode operation can be kept very small. The ripple voltage depends on the PFM comparator delay, the size of the output capacitor and the inductor value. Increasing output capacitor values and/or inductor values will minimize the output ripple.

The PFM mode is left and PWM mode entered in case the output current can not longer be supported in PFM mode or if the output voltage falls below a second threshold, called PFM comparator low threshold. This PFM comparator low threshold is set to  $-1\%$  below nominal  $V_{out}$ , and enables a fast transition from power save mode to PWM Mode during a load step. In power save mode the quiescent current is reduced typically to 19  $\mu$ A.

The power save mode can be disabled through the I2C interface for each of the step-down converters independent from each other. If power save mode is disabled, the converter will then operate in fixed PWM mode.

#### 10.3.9.1 Dynamic Voltage Positioning

This feature reduces the voltage under/overshoots at load steps from light to heavy load and vice versa. It is active in power save mode. It provides more headroom for both the voltage drop at a load step, and the voltage increase at a load throw-off. This improves load transient behavior. At light loads, in which the converter operates in PFM mode, the output voltage is regulated typically 1% higher than the nominal value. In case of a load transient from light load to heavy load, the output voltage drops until it reaches the PFM comparator low threshold set to  $-1\%$  below the nominal value and enters PWM mode. During a load throw off from heavy load to light load, the voltage overshoot is also minimized due to active regulation turning on the low side MOSFET switch.

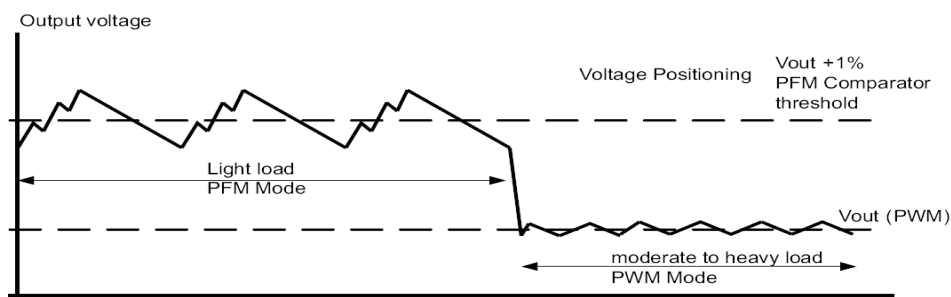

Figure 31. Power Save Mode

### 10.3.9.2 100% Duty Cycle Low Dropout Operation

The device starts to enter 100% duty cycle mode once the input voltage comes close the nominal output voltage. In order to maintain the output voltage, the high side MOSFET switch is turned on 100% for one or more cycles.

With further decreasing  $V_{IN}$  the high side MOSFET switch is turned on completely. In this case the converter offers a low input-to-output voltage difference. This is particularly useful in battery-powered applications to achieve longest operation time by taking full advantage of the whole battery voltage range.

The minimum input voltage to maintain regulation depends on the load current and output voltage, and can be calculated as:

$$V_{in_{min}} = V_{out_{t_{max}}} + I_{out_{t_{max}}} \times (R_{DSon_{n_{max}}} + R_L)$$

where

- $I_{out_{t_{max}}}$  = maximum output current plus inductor ripple current
- $R_{DSon_{n_{max}}}$  = maximum P-channel switch  $R_{DSon}$
- $R_L$  = DC resistance of the inductor
- $V_{out_{t_{max}}}$  = nominal output voltage plus maximum output voltage tolerance (3)

### 10.3.9.3 Undervoltage Lockout

The undervoltage lockout circuit prevents the device from malfunctioning at low input voltages and from excessive discharge of the battery and disables the DC-DC converters and LDOs. The undervoltage lockout threshold is configurable in the range of typically 2.8 V to 3.25 V with falling voltage at the SYS pin. The default undervoltage lockout voltage as well as the hysteresis are defined in register CON\_CTRL2. The default undervoltage lockout voltage is 3 V with 500-mV hysteresis.

### 10.3.10 Short-Circuit Protection

The high side and low side MOSFET switches are short-circuit protected with maximum output current =  $I_{LIMF}$ . Once the high side MOSFET switch reaches its current limit, it is turned off and the low side MOSFET switch is turned. The high side MOSFET switch can only turn on again, once the current in the low side MOSFET switch decreases below its current limit.

#### 10.3.10.1 Soft Start

The 3 step-down converters in TPS6507x have an internal soft start circuit that controls the ramp up of the output voltage. The output voltage ramps up from 5% to 95% of its nominal value within typical 250  $\mu$ s. This limits the inrush current in the converter during start up and prevents possible input voltage drops when a battery or high impedance power source is used. The Soft start circuit is enabled after the start up time  $t_{Start}$  has expired.

During soft start, the output voltage ramp up is controlled as shown in Figure 32.

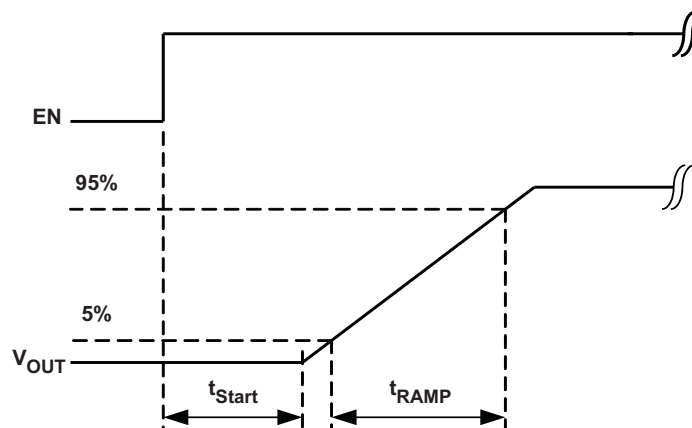

Figure 32. Soft Start

### 10.3.11 Enable

To start up each converter independently, the device has a separate enable pin for each of the DC-DC converters. In order to enable any converter with its enable pins, the TPS6507x devices need to be in ON-state by pulling  $\overline{\text{PB\_IN}}=\text{LOW}$  or  $\text{POWER\_ON}=\text{HIGH}$ . The sequencing option programmed needs to be  $\text{DCDC\_SQ}[2..0] = 101$ .

If  $\text{EN\_DCDC1}$ ,  $\text{EN\_DCDC2}$ ,  $\text{EN\_DCDC3}$  are set to high, the corresponding converter starts up with soft start as previously described.

Pulling the enable pin low forces the device into shutdown, with a shutdown quiescent current as defined in the electrical characteristics. In this mode, the high side and low side MOSFETs are turned-off, and the entire internal control circuitry is switched-off. If disabled, the outputs of the DC-DC converters are pulled low by internal 250- $\Omega$  resistors, actively discharging the output capacitor. For proper operation the enable pins must be terminated and must not be left floating.

Optionally, there is internal sequencing for the DC-DC converters and both LDOs available. Bits  $\text{DCDC\_SQ}[0..2]$  in register  $\text{CON\_CTRL1}$  define the start-up and shut-down sequence for the DC-DC converters. Depending on the sequencing option, the signal at  $\text{EN\_DCDC1}$ ,  $\text{EN\_DCDC2}$  and  $\text{EN\_DCDC3}$  are ignored. For automatic internal sequencing, the enable signals which are not used should be connected to GND.

LDO1 and LDO2 will start up automatically as defined in register  $\text{LDO\_CTRL1}$ . See details about the sequencing options in [CON\\_CTRL1. Register Address: 0Dh](#) and [LDO\\_CTRL1. Register Address: 16h](#).

#### 10.3.11.1 $\overline{\text{RESET}}$ (TPS65070, TPS65073, TPS650731, TPS650732 Only)

The TPS6507x contain circuitry that can generate a reset pulse for a processor with a certain delay time. The input voltage at a comparator is sensed at an input called THRESHOLD. When the voltage exceeds the threshold, the output goes high with the delay time defined in register PGOOD. The reset circuitry is not active in OFF-state. The pullup resistor for this open-drain output must not be connected directly to the battery as this may cause a leakage path when the power path (SYS voltage) is turned off. The reset delay time equals the setting for the PGOOD signal. For devices that are configured with  $\text{EN\_wLED}$  input, the reset output should be left open.

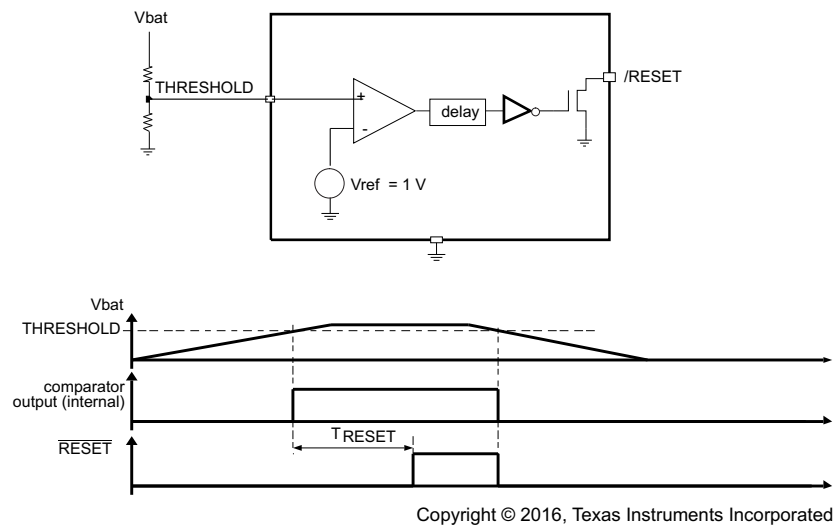

Copyright © 2016, Texas Instruments Incorporated

Figure 33.  $\overline{\text{RESET}}$  Timing

#### 10.3.11.2 PGOOD (Reset Signal For Applications Processor)

This open-drain output generates a power-good signal depending on the status of the power good Bits for the DCDC converters and the LDOs. Register PGOODMASK defines which of the power good Bits of the converters and LDOs are used to drive the external PGOOD signal low when the voltage is below the target value. If for example, Bit MASK DCDC2 is set to 1, the PGOOD pin will be driven low as long as the output of DCDC2 is below the target voltage. If the output voltage of DCDC2 rises to its nominal value, the PGOOD pin will be released after the delay time defined. See [Default Settings](#).

### 10.3.11.3 $\overline{PB\_IN}$ (Push-Button IN)

This pin is the ON/OFF button for the PMU to leave OFF-state and enter ON-state by pulling this pin to GND. Entering ON-state will first ramp the output voltage of the power path (SYS), load the default register settings and start up the DCDC converters and LDOs with the sequencing defined. In ON-state, the I2C interface is active and the wLED converter can be enabled. The system turns on if  $\overline{PB\_IN}$  is pulled LOW for >50 ms (debounce time) AND the output voltage of the power path manager is above the undervoltage lockout voltage ( $AVDD6 > 3\text{ V}$ ). This is for  $V_{bat} > 3\text{ V}$  OR  $V_{AC} > 3\text{ V}$  OR  $V_{USB} > 3\text{ V}$ . The default voltage for the undervoltage lockout voltage can be changed with Bits  $\langle UVLO1 \rangle$ ,  $\langle UVLO0 \rangle$  in register  $CON\_CTRL2$ . The value will be valid until the device was turned off completely by entering Off state. The system turns off if  $\overline{PB\_IN}$  is released OR the system voltage falls below the undervoltage lockout voltage of 3 V. This is the case when either the battery voltage drops below 3 V or the input voltage at the pins AC or USB is below 3 V. In order to keep the TPS6507x enabled after  $\overline{PB\_IN}$  is released HIGH, there is an input pin called POWER\_ON which needs to be pulled HIGH before the  $\overline{PB\_IN}$  button is released.  $POWER\_ON=HIGH$  will typically be asserted by the application processor to keep the PMU in ON-state after the power button at  $\overline{PB\_IN}$  is released.

In addition to this, there is a 15-s timer which will drive  $PGOOD=LOW$  for 0.5 ms when 15 s are expired. The 15-s timer is enabled again when  $\overline{PB\_IN}$  is released HIGH. If  $\overline{PB\_IN}$  is pulled LOW for 30 s continuously,  $PGOOD$  will be driven LOW only once after the first 15 s. When  $PGOOD$  is driven LOW due to  $\overline{PB\_IN}=low$  for 15 s, all registers in TPS6507x are set to their default value. See Figure 34.

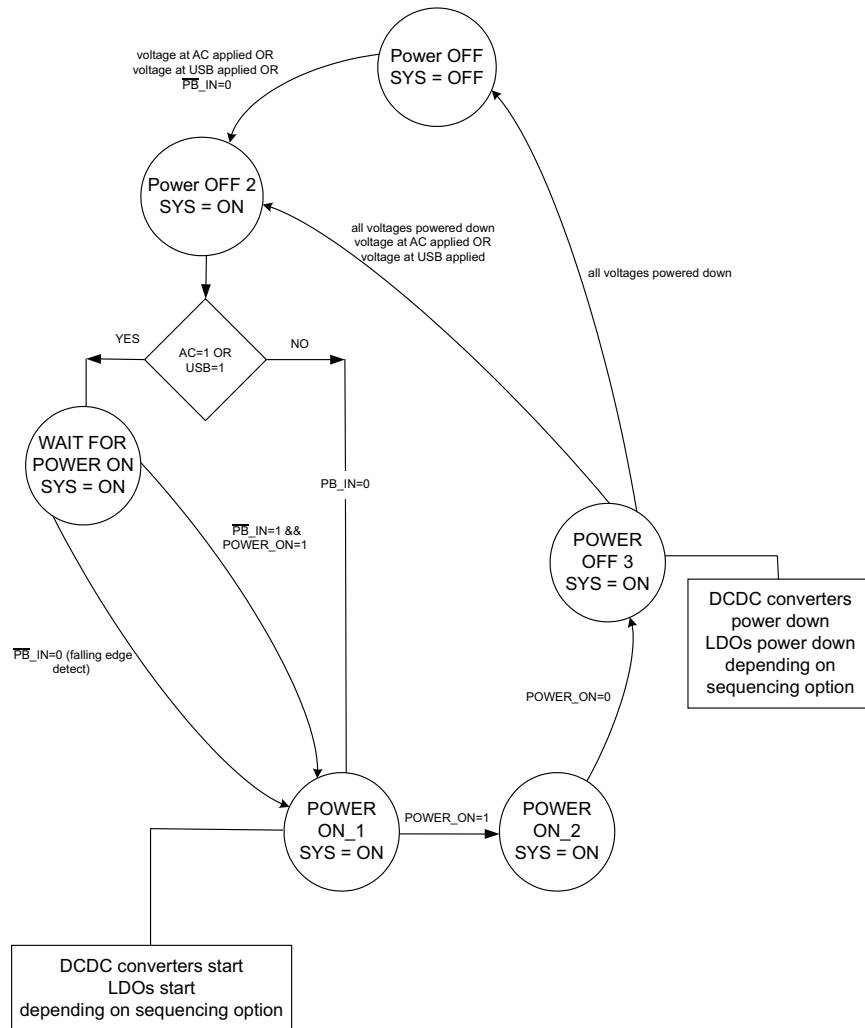

Figure 34. State Machine

#### 10.3.11.4 PB\_OUT

This pin is a status output. PB\_OUT is used as the wake-up interrupt to an application processor based on the status of PB\_IN. If PB\_IN=LOW, PB\_OUT = LOW (after 50-ms debounce). If PB\_IN=HIGH, PB\_OUT= high impedance (HIGH).

The pullup resistor for this open-drain output must not be connected directly to the battery as this may cause a leakage path when the power path (SYS) is turned off.

#### 10.3.11.5 POWER\_ON

This pin is an input to the PMU which needs to be pulled HIGH for the PMU to stay in POWER ON\_2-state once PB\_IN is released. Once this pin is pulled LOW while PB\_IN=LOW, the PMU is shutting down without delay, turning off the DCDC converters and the LDOs. If POWER\_ON is pulled HIGH while there is power at USB or AC, the TPS6507x will enter POWER ON\_2-state and start the DC-DC converters and LDOs according to the sequence programmed. See [Figure 34](#).

#### 10.3.11.6 EN\_wLED (TPS65072 Only)

If the EN\_wLED pin is pulled HIGH, the boost converter is enabled with a default duty cycle of 30% for dimming. If the pin is pulled LOW, the boost convert is disabled. The white LED boost converter can also be enabled with its ENABLE ISINK Bit in register WLED\_CTRL1. The converter is enabled whenever the pin is HIGH OR the Bit is set to 1.

#### 10.3.11.7 EN\_EXTLDO (TPS65072 Only)

The EN\_EXTLDO pin will go high during start-up depending on the sequencing option programmed. The pin will go low again if the TPS6507x is going to OFF state (POWER OFF).

The external LDO is used for the sequencing option DCDC\_SQ[0,2]=111, LDO\_SQ[0,2]=010, used for the Atlas4 processor and with sequencing option DCDC\_SQ[0,2]=100, LDO\_SQ[0,2]=111 used for the Sirf Prima processor. See [Application and Implementation](#) for the timing diagrams.

### 10.3.12 Short-Circuit Protection

All outputs are short-circuit protected with a maximum output current as defined in the electrical specifications.

### 10.3.13 Thermal Shutdown

As soon as the junction temperature,  $T_J$ , exceeds typically 150°C for the DC-DC converters or LDOs, the device goes into thermal shutdown. In this mode, the high side MOSFETs are turned off. The device continues its operation when the junction temperature falls below the thermal shutdown hysteresis again. A thermal shutdown for one of the DCDC converters or LDOs will disable all step-down converters simultaneously.

#### 10.3.13.1 Low Dropout Voltage Regulators

The low dropout voltage regulators are designed to operate well with low value ceramic input and output capacitors. They operate with input voltages down to 1.8 V. The LDOs offer a maximum dropout voltage of 200 mV at rated output current. Each LDO supports a current limit feature. LDO2 is enabled internally using Bit ENABLE\_LDO2 in register CON\_CTRL1. The output voltage for LDO2 is defined by the settings in register DEFLDO2. LDO2 can also be configured in such a way that it follows the output voltage of converter DCDC3 by setting Bit LDO2 TRACKING = 1 in register DEFLDO2.

LDO1 is enabled internally using Bit ENABLE\_LDO1 in register CON\_CTRL1. The output voltage for LDO1 is defined by the settings in register LDO\_CTRL1 can also be enabled automatically depending on the settings in register LDO\_CTRL1.

#### 10.3.13.2 White LED Boost Converter

The converter is in shutdown mode by default and is being turned on by setting the enable Bit with the I2C interface or for TPS65072 with pin EN\_wLED. The enable Bit is located in register WLED\_CTRL1 and is called ENABLE ISINK as it enables the current sink for the white LEDs. Once enabled, an output voltage is automatically generated at FB\_wLED, high enough to force the programmed current through the string of white LEDs. Two strings of white LEDs can be powered. The current in each of the two strings is regulated by an internal current sink at pins Isink1 and Isink2. The maximum current through the current sinks is set with two

external resistors connected from pins ISET1 and ISET2 to GND. ISET1 sets the maximum current when Bit CURRENT LEVEL in register WLED\_CTRL2 is set to 1. If this Bit is set to 0, which is the default setting, the maximum current is defined by the resistor connected at ISET2. This allows change between two different maximum current settings during operation. The LED current can further be dimmed with an internal PWM signal. The duty cycle for this PWM signal can be changed with the Bits LED DUTY CYCLE 0 to LED DUTY CYCLE 6 in register WLED\_CTRL2 in a range from 1% to 100%. In case a dimming ratio higher than 1:100 is needed, the maximum LED current need to be changed to a lower value as defined with Iset2. In order to do this without any flicker, the PWM dimming and the current level is defined in the same register, so both settings can be changed at the same time with a single write access to register WLED\_CTRL2. An internal overvoltage protection limits the maximum voltage at FB\_wLED to 37 V typically. The output voltage at FB\_WLED also has a lower limit which is set to 12 V. In case less than 4LEDs are used, the output voltage at the boost converter will not drop below 12 V but the voltage from ISINK1 and ISINK2 to GND is increased accordingly.

### 10.3.13.3 A/D Converter

The 10Bit successive approximation (SAR) A/D converter with an input multiplexer can be used to monitor different voltages in the system. These signals are monitored:

- Battery voltage
- Voltage at AC input
- Voltage at SYS output
- Input voltage of battery charger
- Battery temperature
- Battery charge current (voltage at pin Iset;  $I_{charge} = U_{ISET}/R_{set} \times K_{ISET}$ )
- External voltage 1 to external voltage 4 (AD\_IN1 to AD\_IN4); 0 V to 2.25 V
- Optionally: External voltage 5 to external voltage 7 (AD\_IN5 to AD\_IN7); 0 V to 6 V
- Internal channel AD\_IN14 and AD\_IN15 for touch screen measurements

The A/D converter uses an internal 2.26-V reference. The reference needs a bypass capacitor for stability which is connected to pin BYPASS. The pin can be used as a reference output with a maximum output current of 0.1 mA. The internal reference voltage is forced to be on when the ADC or the touch screen interface is enabled. The reference voltage can additionally forced to be on using Bit Vref\_enable in register ADCONFIG while ADC and touch screen are off to allow external circuits to be supplied with a precise reference voltage while ADC and touch screen are not used.

### 10.3.13.4 Touch Screen Interface (only for TPS65070, TPS65073, TPS650731, TPS650732)

The touch screen itself consists of two parallel plates, called the X and Y plates, separated by short distance; contact is initiated by using a stylus or your finger. This action creates a series of resistances noted by RX1, RX2, RY1, RY2, and Rcontact, shown in [Figure 36](#). The points shown in the diagram as TSX1, TSX2, TSY1 and TSY2 are connected to the TPS6507x touch screen interface. The resistances RX1 and RX2 scale linearly with the x-position of the point of contact, where the RY1 and RY2 resistances scale with the y-position. The Rcontact resistance decreases as the pressure applied at the point of contact increases and increases as the pressure decreases. Using these relationships, the touch screen interface can make measurements of either position or pressure.

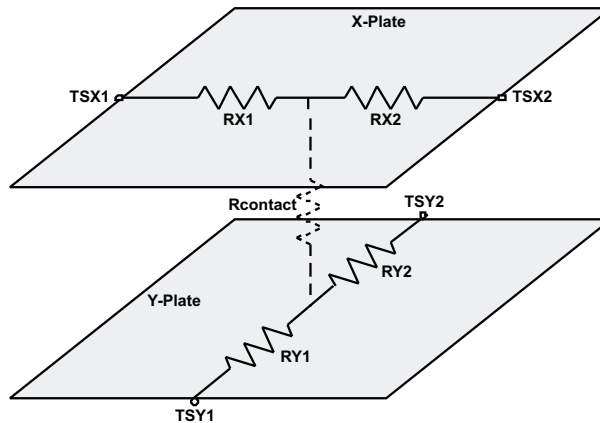

Figure 35. Touch Screen

The touch screen interface consists of a digital state machine, a voltage reference, and an analog switch matrix which is connected to the four wire resistive touch screen inputs (TSX1, TSX2, TSY1, TSY2) and an internal 10-Bit ADC. The state machine controls the sequencing of the switch matrix to cycle through the three types of measurement modes (position, pressure, plate resistance) and the low power standby mode. The separate internal voltage reference (TSREF) is disabled in standby and off modes. The voltage is generated by an internal LDO. Its voltage is bypassed by a capacitor connected to pin INT\_LDO. The state of the touch screen is controlled by the TSC\_M[2,0] Bits of the TSCMODE register (08h) as shown in Table 3. The touch screen controller uses transfer gates to the internal ADC on input channels AD\_IN14 and AD\_IN15.

Table 3. TSC Modes

CONTROL MULTIPLEXER			CONNECTIONS				MODE	MEASUREMENT
TSC_M2	TSC_M1	TSC_M0	TSX1	TSX2	TSY1	TSY2		
0	0	0	TSREF PMOS	GND NMOS	ADC_IN3 TGATE	ADC_IN4 TGATE	X-Position	Voltage TSY1
0	0	1	ADC_IN1 TGATE	ADC_IN2 TGATE	TSREF PMOS	GND NMOS	Y-Position	Voltage TSX1
0	1	0	TSREF	TSREF	GND NMOS	GND NMOS	Pressure	Current TSX1 and TSX2
0	1	1	TSREF PMOS	GND NMOS	HiZ	HiZ	Plate X Reading on ADC_IN14	Current TSX1
1	0	0	HiZ	HiZ	TSREF PMOS	GND NMOS	Plate Y Reading on ADC_IN14	Current TSY1
1	0	1	TSREF TGATE	TSREF TGATE	GND NMOS	GND NMOS	TSC standby	Voltage TSX1 and TSX2
1	1	0	A/D TGATE	A/D TGATE	A/D TGATE	A/D TGATE	A/D	ADC used as stand alone ADC using its analog inputs
1	1	1	OPEN	OPEN	OPEN	OPEN	Disabled (no interrupt)	None

If the Touch screen multiplexer is set to disabled mode [111], touch to the screen will not be detected. Standby mode is entered by setting TSC\_M[2:0] to 101. When there is a touch, the controller will detect a change in voltage at the TSX1 point and after a 8ms deglitch the INT pin will be asserted if the interrupt is unmasked in register INT. Once the host detects the interrupt signal, will enable the ADC converter and set the TSC\_M[2:0] through the I<sup>2</sup>C bus to select any of five measurements (position, pressure, plate) as shown in Table 4.

Table 4. TSC Equations

MEASUREMENT	CHANNEL	EQUATION
X Plate resistance	AD_IN14	$R_x = V_{TSREF} / [(V_{ADC} / 22k) \times 150]$
Y plate resistance	AD_IN14	$R_y = V_{TSREF} / [(V_{ADC} / 22k) \times 150]$
X position	AD_IN14	$X_{pos} = R_{x2} / (R_{x1} + R_{x2}) = R_{x2} / R_x$ $R_{x2} = V_{ADC} \times R_x / V_{TSREF}; R_{x1} = R_x - R_{x2}$ $X_{pos} = ADRESULT / 1024$
Y position	AD_IN14	$Y_{pos} = R_{y2} / (R_{y1} + R_{y2}) = R_{y2} / R_y$ $R_{y2} = V_{ADC} \times R_y / V_{TSREF}; R_{y1} = R_y - R_{y2}$ $Y_{pos} = ADRESULT / 1024$
Pressure	AD_IN14	$R_c = R - R_{x1} // R_{x2} - R_{y1} // R_{y2}$ $R = V_{TSREF} / [(V_{ADC} / 22k) \times 150]$ $R_{x1} // R_{x2} = R_x \times X_{pos} \times (1 - X_{pos})$ $R_{y1} // R_{y2} = R_y \times Y_{pos} \times (1 - Y_{pos})$

10.3.13.4.1 Performing Measurements Using the Touch Screen Controller

To take measurements with the touch screen controller, the ADC has to be enabled and configured for use with the touch screen controller (TSC) first. In case the TSC is planned to be operated interrupt driven, the TSC needs to be in *TSC standby* mode per default. Only in *TSC standby* mode an interrupt is generated based on a *touch* of the screen. The TSC should therefore be in this mode until a *touch* is detected. Afterwards, the TSC has to be configured for x-position measurement followed by y-position measurement. Now, the TSC can be set to *TSC standby* again to wait for the next *touch* of the screen. For a non-interrupt driven sequence, see TSCMODE. Register Address: 08h (page 50) in the *Registers* section. A typical interrupt driven sequence is given below:

- Set TSCMODE to 101 to set TSC to *TSC standby*, so an interrupt is generated when the screen is touched
- Set Bit AD enable = 1 to provide power to the ADC
- Set input select for the ADC in register ADCONFIG to 1110 (AD\_IN14 selected)
- In register INT, set MASK TSC = 1 to unmask the interrupt on a *touch* of the touch screen
- Read Bit TSC INT as it will be set after the TSC has been configured. Reading clears the interrupt.
- After a *touch* was detected, an interrupt is generated by  $\overline{INT}$  pin going LOW
- Read Bit TSC INT to clear the interrupt
- Set TSCMODE to 000 to select *x-position measurement*
- Start an ADC conversion by setting CONVERSION START = 1; wait until END OF CONVERSION = 1
- Read register ADRESULT\_1 and AD\_RESULT\_2
- Set TSCMODE to 001 to select *y-position measurement*
- Start an ADC conversion by setting CONVERSION START = 1; wait until END OF CONVERSION = 1
- Read register ADRESULT\_1 and AD\_RESULT\_2
- Set TSCMODE to 101 to set TSC to *TSC standby* again

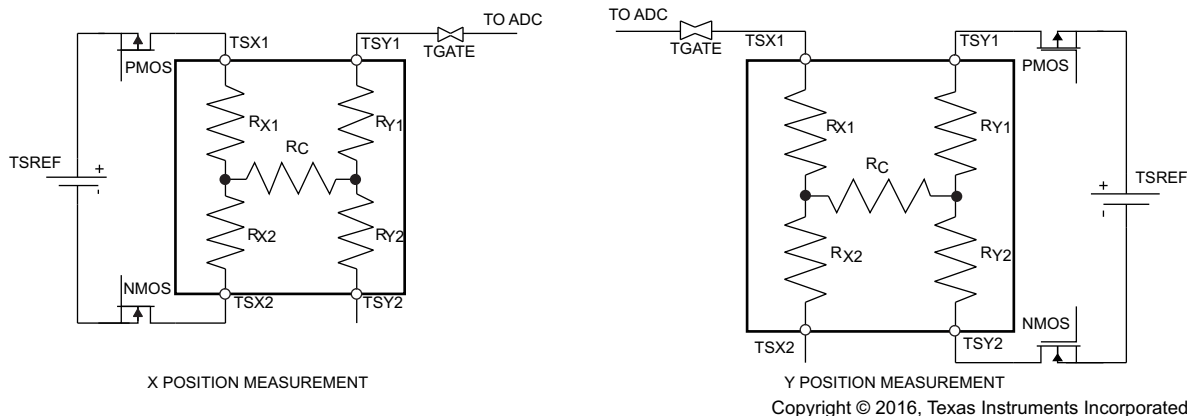

Figure 36. Two Position Measurement

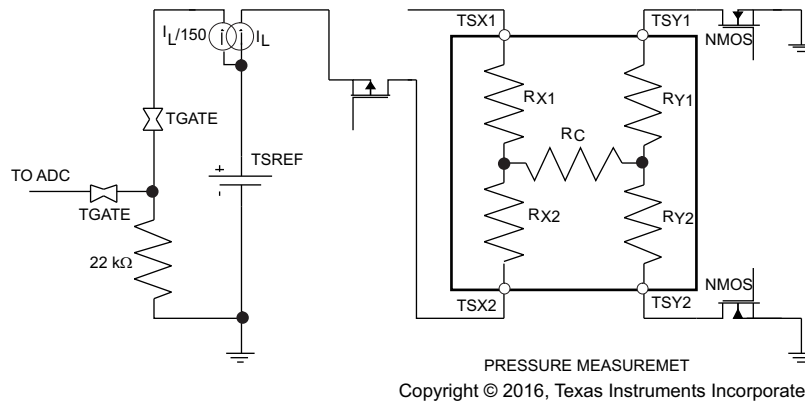

Figure 37. Pressure Measurement

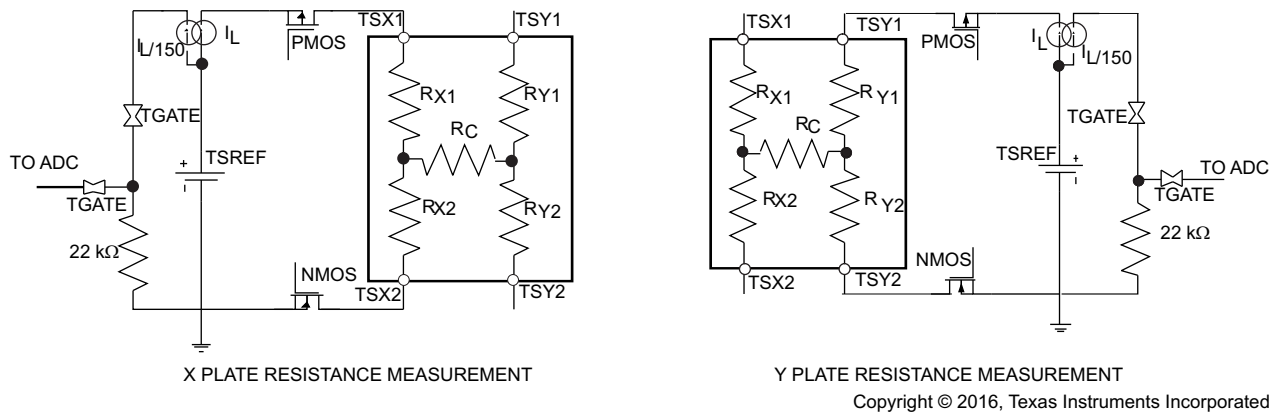

Figure 38. Two Plate Resistance Measurement

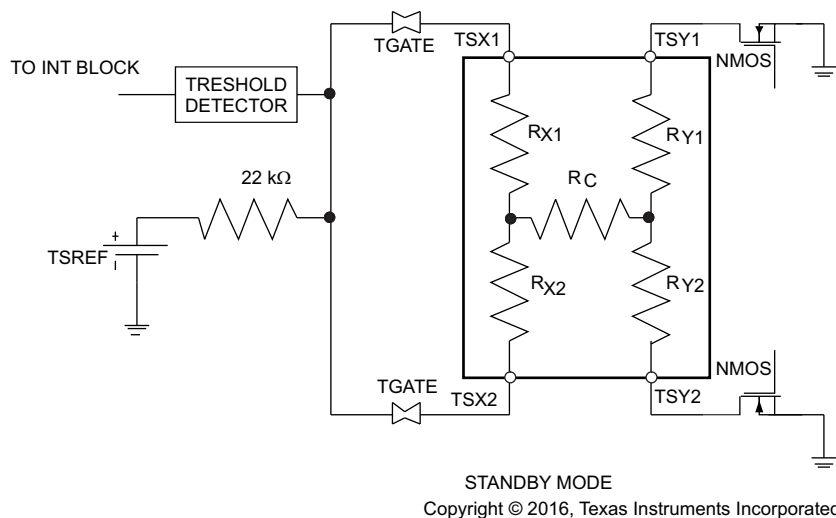

Figure 39. Touch Screen Standby Mode

## 10.4 Device Functional Modes

The device can be in an operational charge enabled mode or overvoltage protection mode. To allow for charging the AC or USB must be with in the valid charging range which, is between the UVLO and OVP.

## 10.5 Programming

### 10.5.1 I<sup>2</sup>C Interface Specification

#### 10.5.1.1 Serial interface

The serial interface is compatible with the standard and fast mode I<sup>2</sup>C specifications, allowing transfers at up to 400 kHz. The interface adds flexibility to the power supply solution, enabling most functions to be programmed to new values depending on the instantaneous application requirements and charger status to be monitored. The TPS6507x has a 7-Bit address: 1001000, other addresses are available upon contact with the factory. Attempting to read data from register addresses not listed in this section will result in 00h being read out. For normal data transfer, SDAT is allowed to change only when SCLK is low. Changes when SCLK is high are reserved for indicating the start and stop conditions. During data transfer, the data line must remain stable whenever the clock line is high. There is one clock pulse per Bit of data. Each data transfer is initiated with a start condition and terminated with a stop condition. When addressed, the device generates an acknowledge Bit after the reception of each byte. The master device (microprocessor) must generate an extra clock pulse that is associated with the acknowledge Bit. The TPS6507x device must pull down the SDAT line during the acknowledge clock pulse so that the SDAT line is a stable low during the high period of the acknowledge clock pulse. The SDAT line is a stable low during the high period of the acknowledge-related clock pulse. Setup and hold times must be taken into account. During read operations, a master must signal the end of data to the slave by not generating an acknowledge Bit on the last byte that was clocked out of the slave. In this case, the slave TPS6507x device must leave the data line high to enable the master to generate the stop condition.

All registers are set to their default value by one of these conditions:

- Voltage is below the UVLO threshold defined with registers <UVLO1>, <UVLO0>
- $\overline{\text{PB\_IN}}$  is asserted LOW for >15s (option)

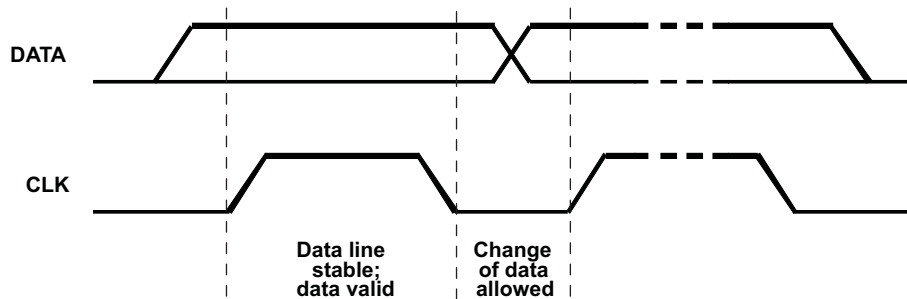

Figure 40. Bit Transfer on the Serial Interface

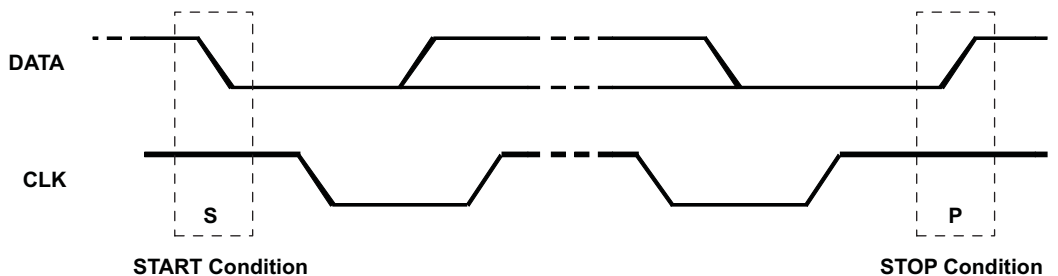
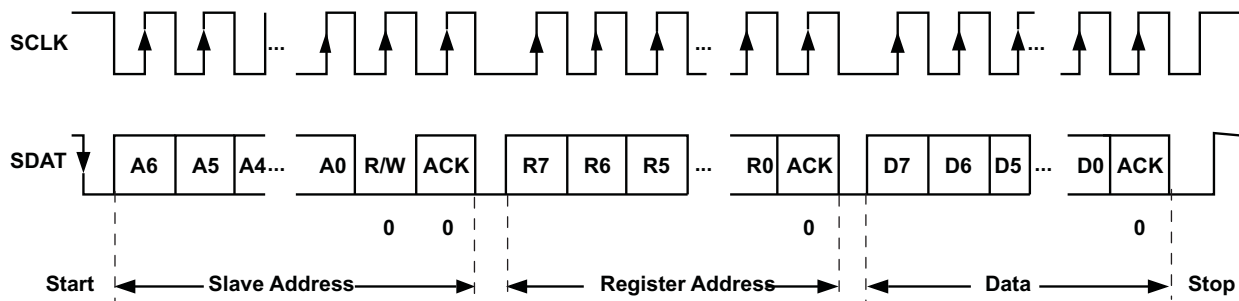

Figure 41. START and STOP Conditions

Programming (continued)



NOTE: SLAVE=TPS6507x

Figure 42. Serial Interface WRITE to TPS6507x

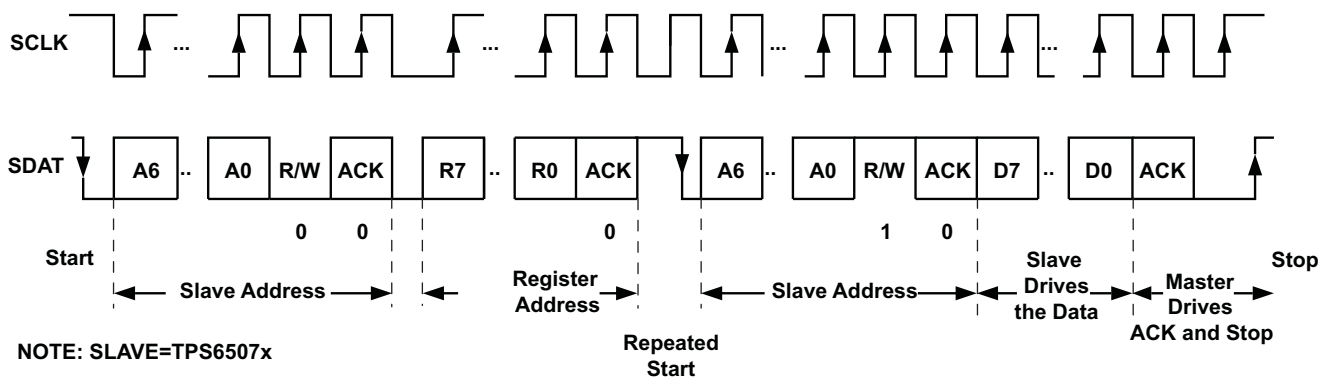

NOTE: SLAVE=TPS6507x

Figure 43. Serial Interface READ from TPS6507x: Protocol A

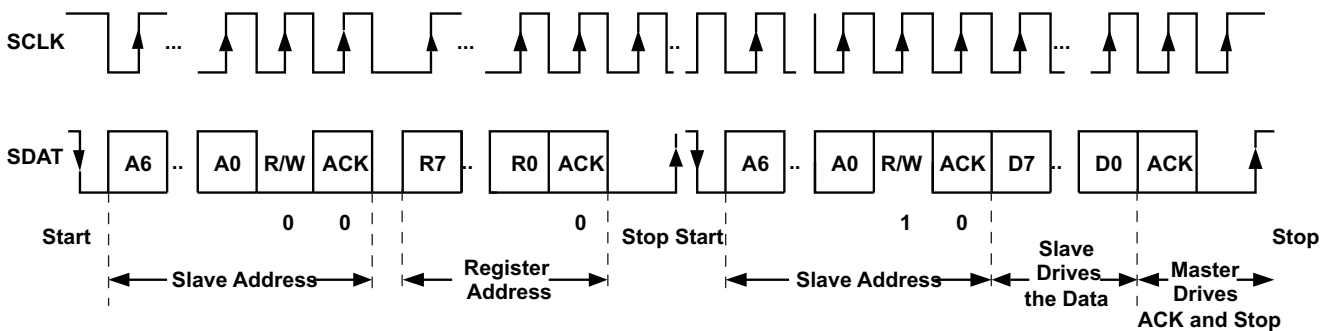

Figure 44. Serial Interface READ from TPS6507x: Protocol B

## 10.6 Register Maps

**Table 5. Register Summary**

ADDRESS	NAME	SHORT DESCRIPTION
0x01h	PPATH1	Power Path Controls
0x02h	INT	Interrupt Reporting and Masking
0x03h	CHGCONFIG0	Battery Charger Configuration
0x04h	CHGCONFIG1	Battery Charger Configuration
0x05h	CHGCONFIG2	Battery Charger Configuration
0x06h	CHGCONFIG3	Battery Charger Configuration
0x07h	ADCONFIG	ADC Configuration and Control
0x08h	TSCMODE	Touch Screen Interface Control
0x09h	ADRESULT_1	ADC Result LSBs
0x0Ah	ADRESULT_2	ADC Result MSBs
0x0Bh	PGOOD	Power Good Reporting
0x0Ch	PGOODMASK	Power Good Masking
0x0Dh	CON_CTRL1	Sequence and Enable Control Bits for DCDCs and LDOs
0x0Eh	CON_CTRL2	Control Bits for Timers, UVLO, and DCDC2 / DCDC3
0x0Fh	CON_CTRL3	Discharge Resistors and Force PWM Mode
0x10h	DEFDCDC1	Output Voltage Setting for DCDC1
0x11h	DEFDCDC2_LOW	Output Voltage Setting for DCDC2 if DEFDCDC2 is LOW
0x12h	DEFDCDC2_HIGH	Output Voltage Setting for DCDC2 if DEFDCDC2 is HIGH
0x13h	DEFDCDC3_LOW	Output Voltage Setting for DCDC3 if DEFDCDC3 is LOW
0x14h	DEFDCDC3_HIGH	Output Voltage Setting for DCDC3 if DEFDCDC3 is HIGH
0x15h	DEFSLEW	Define Slew Rate for DCDC2 & DCDC3 DVS
0x16h	LDO_CTRL1	Sequence and Output Voltage Control for LDOs
0x17h	DEFLDO2	Output Voltage Control for LDO2
0x18h	WLED_CTRL1	wLED Control Bits
0x19h	WLED_CTRL2	wLED Control Bits

### 10.6.1 PPATH1. Register Address: 01h

PPATH1	B7	B6	B5	B4	B3	B2	B1	B0
Bit name and function	USB power	AC power	$\overline{\text{USB}}$ power enable	$\overline{\text{AC}}$ power enable	AC input current MSB	AC input current LSB	USB input current MSB	USB input current LSB
Default	x	x	0	0	1	1	0	1
Set by signal								
Default value loaded by:			UVLO	UVLO	Voltage removed at AC OR UVLO	Voltage removed at AC OR UVLO	Voltage removed at USB OR UVLO	Voltage removed at USB OR UVLO
Read/write	R	R	R/W	R/W	R/W	R/W	R/W	R/W

- Bit 7 USB power:  
 0 = USB power is not present and/or not in the range valid for charging  
 1 = USB source is present and in the range valid for charging. B7 remains active as long as the charge source is present
- Bit 6 AC power:  
 0 = wall plug is not present and/or not in the range valid for charging  
 1 = wall plug source is present and in the range valid for charging. B6 remains active as long as the charge source is present
- Bit 5  $\overline{\text{USB}}$  POWER ENABLE  
 0 = USB power input is enabled  
 1 = USB power input is disabled (USB suspend mode)
- Bit 4  $\overline{\text{AC}}$  POWER ENABLE  
 0 = AC power input is enabled  
 1 = AC power input is disabled
- Bit 3..2 AC INPUT CURRENT  
 00 = input current from AC input is 100 mA max  
 01 = input current from AC input is 500 mA max  
 10 = input current from AC input is 1300 mA max  
 11 = input current from AC input is 2500 mA
- Bit 1..0 USB INPUT CURRENT  
 00 = input current from USB input is 100 mA max  
 01 = input current from USB input is 500 mA max  
 10 = input current from USB input is 800 mA max  
 11 = input current from USB input is 1300 mA max

Note: safety timers are cleared if the input voltage at both AC and USB are removed.

**10.6.2 INT. Register Address: 02h**

INT	B7	B6	B5	B4	B3	B2	B1	B0
Bit name and function	MASK AC/USB	MASK TSC	MASK $\overline{\text{PB\_IN}}$		TSC INT	$\overline{\text{PB\_IN}}$ INT	USB or AC input voltage applied	USB or AC input voltage removed
Default	0	0	0	0	0	0	0	0
Set by signal					Cleared when read	Cleared when read	Cleared when read	Cleared when read
Default value loaded by:	UVLO	UVLO	UVLO		UVLO	UVLO	UVLO	UVLO
Read/write	R/W	R/W	R/W	R	R	R	R	R

**Bit 7 MASK AC/USB**

0 = no interrupt generated if voltage at AC or USB is applied or removed

 1 = the pin  $\overline{\text{INT}}$  is actively pulled low if one of the Bits 1 to Bit 0 are 1

**Bit 6 MASK TSC**

0 = no interrupt generated if the touch screen is detecting a “touch”

 1 = the pin  $\overline{\text{INT}}$  is actively pulled low if a “touch” on the touch screen is detected

**Bit 5 MASK  $\overline{\text{PB\_IN}}$** 

 0 = no interrupt generated if the  $\overline{\text{PB\_IN}}$  is pulled low.

 1 = the pin  $\overline{\text{INT}}$  is actively pulled low if  $\overline{\text{PB\_IN}}$  was pulled low.

**Bit 3 TSC INT**

0 = no “touch” on the touch screen detected

1 = “touch” detected and the Bit has not been read ever since

**Bit 2  $\overline{\text{PB\_IN}}$  INT**

 0 =  $\overline{\text{PB\_IN}}$  not active

 1 =  $\overline{\text{PB\_IN}}$  is actively pulled low (or high optionally) and the Bit has not been read ever since

**Bit 1 USB or AC INPUT VOLTAGE APPLIED**

0 = no change (voltage still applied or never applied)

1 = voltage at USB or AC has been applied and the Bit has not been read ever since

**Bit 0 USB or AC INPUT VOLTAGE REMOVED**

0 = no change (voltage still applied or never applied)

1 = the voltage at USB or AC has been removed and the Bit has not been read ever since

### 10.6.3 CHGCONFIG0. Register Address: 03h

CHGCONFIG0	B7	B6	B5	B4	B3	B2	B1	B0
Bit name and function	Thermal regulation	DPPM active	Thermal Suspend	Term Current		Chg Timeout	Prechg Timeout	BatTemp error
Default	x	x	x	x	0	x	x	x
Set by signal								
Default value loaded by:	UVLO	UVLO	UVLO	UVLO		UVLO	UVLO	UVLO
Read/write	R	R	R	R	R	R	R	R

- Bit 7      THERMAL REGULATION:  
 0 = charger is in normal operation  
 1 = charge current is reduced due to high chip temperature
- Bit 6      DPPM ACTIVE:  
 0 = DPPM loop is not active  
 1 = DPPM loop is active; charge current is reduced to support the load with the current required
- Bit 5      THERMAL SUSPEND:  
 0 = charging is allowed  
 1 = charging is momentarily suspended because battery temperature is out of range
- Bit 4      TERM CURRENT:  
 0 = charge termination current threshold has not been crossed; charging or no voltage at AC and USB  
 1 = charge termination current threshold has been crossed and charging has been stopped. This can be due to a battery reaching full capacity or to a battery removal condition
- Bit 2..Bit1    CHG TIMEOUT, PRECHG TIMEOUT  
 0 = charging, timers did not time out  
 1 = one of the timers has timed out and charging has been terminated
- Bit 0      BAT TEMP ERROR:  
 0 = battery temperature is in the allowed range for charging  
 1 = no temperature sensor detected

**10.6.4 CHGCONFIG1. Register Address: 04h**

CHGCONFIG1	B7	B6	B5	B4	B3	B2	B1	B0
Bit name and function	Charge safety timer value1	Charge safety timer value0	Safety timer enable	SENSOR TYPE	Charger reset	Charge Termination ON/OFF	Suspend Charge	Charger enable
Default	0	0	1	1	0	0	0	1
Set by signal								
Default value loaded by:	UVLO	UVLO	UVLO	UVLO	UVLO	UVLO	UVLO	UVLO
Read/write	R/W	R/W	R/W	R/W	R/W	R/W	R/W	R/W

**Bit 7..6 CHARGE SAFETY TIMER VALUE0/1:**

- 00 = safety timer times out after 4 hours
- 01 = safety timer times out after 5 hours
- 10 = safety timer times out after 6 hours
- 11 = safety timer times out after 8 hours

**Bit 5 SAFETY TIMER ENABLE**

- 0 = precharge timer, fast charge timer and taper timers are disabled
- 1 = precharge timer, fast charge timer and taper timers are enabled

**Bit 4 SENSOR TYPE (NTC for battery temperature measurement)**

- 0 = 100-kΩ curve 1 NTC
- 1 = 10-kΩ curve 2 NTC

**Bit 3 CHARGER RESET:**

- 0 = inactive
- 1 = Reset active. This Bit must be set and then reset through the serial interface to restart the charge algorithm

**Bit 2 CHARGE TERMINATION ON/OFF:**

- 0 = charge termination enabled, based on timers and termination current
- 1 = charge termination will not occur and the charger will always be on

**Bit 1 SUSPEND CHARGE:**

- 0 = Safety Timer and Precharge timers are not suspended
- 1 = Safety Timer and Precharge timers are suspended

**Bit 0 CHARGER ENABLE**

- 0 = charger is disabled
- 1 = charger is enabled; toggling the enable Bit will not reset the charger. Use CHARGER RESET Bit to reset charger.

### 10.6.5 CHGCONFIG2. Register Address: 05h

CHGCONFIG2	B7	B6	B5	B4	B3	B2	B1	BO
Bit name and function	Dynamic Timer function	Precharge voltage	Charge voltage selection1	Charge voltage selection0				
Default	1	1	1	0	0	0	0	0
Set by signal								
Default value loaded by:	UVLO	UVLO	UVLO	UVLO				
Read/write	R/W	R/W	R/W	R/W	R	R	R	R

- Bit 7      **DYNAMIC TIMER FUNCTION**  
 0 = safety timers run with their nominal clock speed  
 1 = clock speed is divided by 2 if thermal loop or DPPM loop is active
- Bit 6      **PRECHARGE VOLTAGE**  
 0 = precharge to fast charge transition voltage is 2.5 V  
 1 = precharge to fast charge transition voltage is 2.9 V
- Bit 5..4   **CHARGE VOLTAGE SELECTION0/1:**  
 00 = 4.1 V  
 01 = 4.15 V  
 10 = 4.2 V  
 11 = 4.25 V

**10.6.6 CHGCONFIG3. Register Address: 06h**

CHGCONFIG3	B7	B6	B5	B4	B3	B2	B1	B0
Bit name and function	Disable Isink at AC	Power path DPPM threshold1	Power path DPPM threshold0	Precharge time	Termination current factor1	Termination current factor0	Charger active	Disable Isink at USB
Default	0	1	1	0	0	1	x	0
Set by signal								
Default value loaded by:	UVLO	UVLO	UVLO	UVLO	UVLO	UVLO	UVLO	UVLO
Read/write	R/W	R/W	R/W	R/W	R/W	R/W	R	R/W

Bit 7 DISABLE ISINK AT AC (disables an internal current sink from pin AC to GND)

0 = 60  $\mu$ A current sink enabled when no input voltage at pin AC detected

1 = 60  $\mu$ A current sink disabled

Bit 6..5 POWER PATH DPPM THRESHOLD1/0:

00 = 3.5 V

01 = 3.75 V

10 = 4.25 V

11 = 4.50 V

Bit 4 PRECHARGE TIME

0 = precharge time is 30 min

1 = precharge time is 60 min

Bit 3..2 TERMINATION CURRENT FACTOR1/0:

00 = 0.04

01 = 0.1

10 = 0.15

11 = 0.2

Bit 1 CHARGER ACTIVE:

0 = charger is not charging

1 = charger is charging (DPPM or thermal regulation may be active)

Bit 0 DISABLE ISINK AT USB (disables an internal current sink from pin USB to GND)

0 = 60- $\mu$ A current sink enabled when no input voltage at pin USB detected

1 = 60- $\mu$ A current sink disabled

Note: There is a current sink on pins AC and USB which is activated when there is no voltage detected at the pin and Bit7 or Bit0 in CHCONFIG3 are set to 0. This is implemented in order to avoid the pins to be floating when not connected to a power source. The current sink is disabled automatically as soon as an input voltage is detected at the pin.

### 10.6.7 ADCONFIG. Register Address: 07h

ADCONFIG	B7	B6	B5	B4	B3	B2	B1	B0
Bit name and function	AD enable	Conversion start	End of conversion	Vref enable	INPUT SELECT_3	INPUT SELECT_2	INPUT SELECT_1	INPUT SELECT_0
Default	0	0	1	0	0	0	0	0
Set by signal								
Default value loaded by:	UVLO	UVLO	UVLO	UVLO	UVLO	UVLO	UVLO	UVLO
Read/write	R/W	R/W	R	R/W	R/W	R/W	R/W	R/W

**Bit 7 AD ENABLE:**

- 0 = A/D converter disabled
- 1 = A/D converter enabled

**Bit 6 CONVERSION START**

- 0 = no conversion in progress
- 1 = start A/D conversion, Bit is automatically cleared if conversion is done

**Bit 5 END OF CONVERSION**

- 0 = conversion did not finish
- 1 = conversion done

**Bit 4 VREF ENABLE**

- 0 = reference voltage LDO (pin BYPASS) for ADC is disabled
- 1 = reference voltage LDO (pin BYPASS) for ADC is enabled

**Bit 3..0 INPUT SELECT – see table**

INPUT SELECT_3	INPUT SELECT_2	INPUT SELECT_1	INPUT SELECT_0	FULL SCALE INPUT VOLTAGE	INPUT SELECTED
0	0	0	0	2.25V	Voltage at AD_IN1
0	0	0	1	2.25V	Voltage at AD_IN2
0	0	1	0	2.25V	Voltage at AD_IN3
0	0	1	1	2.25V	Voltage at AD_IN4
0	1	0	0	2.25V	Voltage at TS pin
0	1	0	1	2.25V	Voltage at ISET pin == battery charge current
0	1	1	0	6.0V	Voltage at AC pin
0	1	1	1	6.0V	Voltage at SYS pin
1	0	0	0	6.0V	Input voltage of the charger
1	0	0	1	6.0V	Voltage at BAT pins
1	0	1	0	6.0V	Voltage at AD_IN5 (at pin THRESHOLD)
1	0	1	1	6.0V	Voltage at AD_IN6 (at pin ISET1)
1	1	0	0	6.0V	Voltage at AD_IN7 (at pin ISET2)
1	1	1	0	2.25	Touch screen controller (TSC); all functions
1	1	1	1	2.25	Touch screen controller (TSC); x-position and y-position only

### 10.6.8 TSCMODE. Register Address: 08h

TSCMODE	B7	B6	B5	B4	B3	B2	B1	B0
Bit name and function						TSC_M2	TSC_M1	TSC_M0
Default	0	0	0	0	0	1	1	1
Set by signal								
Default value loaded by:						UVLO	UVLO	UVLO
Read/write	R	R	R	R	R	R/W	R/W	R/W

#### Bit 3.0 MODE SELECT BITS FOR THE TOUCH SCREEN INTERFACE

Note: Data conversions using the touch screen interface require setting the touch screen mode with register TSCMODE and selecting the analog input channel for the ADC according to the following table.

Measurement of x-position:

- Set TSCMODE to 000 to select x-position measurement
- Set Bit AD\_ENABLE=1 to provide power to the ADC.
- Set input select for the ADC in register ADCONFIG to 1110 (AD\_IN14 selected).
- Start a conversion by setting CONVERSION\_START=1; wait until END\_OF\_CONVERSION=1
- Read register ADRESULT\_1 and ADRESULT\_2

TSC_M2	TSC_M1	TSC_M0	TSX1 (AD_IN1)	TSX2 (AD_IN2)	TSY1(AD_ IN3)	TSY2(AD_ IN4)	MODE	MEASUREMENT
0	0	0	TSREF	GND	A/D	HiZ	X-Position	Voltage TSY1
0	0	1	A/D	HiZ	TSREF	GND	Y-Position	Voltage TSX1
0	1	0	TSREF	TSREF	GND	GND	Pressure	Current TSX1 and TSX2
0	1	1	TSREF	GND	HiZ	HiZ	Plate X	Current TSX1
1	0	0	HiZ	HiZ	TSREF	GND	Plate Y	Current TSY1
1	0	1	V2	V2	GND	GND	TSC standby	Voltage TSX1 and TSX2
1	1	0	A/D	A/D	A/D	A/D	A/D	Voltage measurement with ADC
1	1	1	open	open	open	open	TSC and ADC disabled (no interrupt generation)	

### 10.6.9 ADRESULT\_1. Register Address: 09h

ADRESULT_1	B7	B6	B5	B4	B3	B2	B1	B0
Bit name and function	AD_BIT7	AD_BIT6	AD_BIT5	AD_BIT4	AD_BIT3	AD_BIT2	AD_BIT1	AD_BIT0 LSB
Default	x	x	x	x	x	x	x	x
Set by signal								
Default value loaded by:	R	R	R	R	R	R	R	R
Read/write								

### 10.6.10 ADRESULT\_2. Register Address: 0Ah

ADRESULT_2	B7	B6	B5	B4	B3	B2	B1	B0
Bit name and function							AD_BIT9 MSB	AD_BIT8
Default	0	0	0	0	0	0	x	x
Set by signal								
Default value loaded by:	R	R	R	R	R	R	R	R
Read/write								

### 10.6.11 PGOOD. Register Address: 0Bh

PGOOD	B7	B6	B5	B4	B3	B2	B1	B0
Bit name and function	$\overline{\text{Reset}}$	PGOOD DELAY 1	PGOOD DELAY 0	PGOOD VDCDC1	PGOOD VDCDC2	PGOOD VDCDC3	PGOOD LDO1	PGOOD LDO2
Default for -70, -73, -731, -732	x	1	1					
Default for TPS65072	x	0	0					
Set by signal				PGOOD VDCDC1	PGOOD VDCDC2	PGOOD VDCDC3	PGOOD LDO1	PGOOD LDO2
Default value loaded by:				PGOOD VDCDC1	PGOOD VDCDC2	PGOOD VDCDC3	PGOOD LDO1	PGOOD LDO2
Read/write	R	R/W	R/W	R	R	R	R	R

Bit 7  $\overline{\text{Reset}}$ :

0 = indicates that the comparator input voltage is above the 1V threshold.  
 1 = indicates that the comparator input voltage is below the 1V threshold.

Bit 6..5 PGOOD DELAY 0,1 (sets the delay time of  $\overline{\text{Reset}}$  and PGOOD output):

00 = delay is 20 ms  
 01 = delay is 100 ms  
 10 = delay is 200 ms  
 11 = delay is 400 ms

Bit 4 PGOOD VDCDC1:

0 = indicates that the VDCDC1 converter output voltage is below its target regulation voltage or disabled.  
 1 = indicates that the VDCDC1 converter output voltage is within its nominal range.

Bit 3 PGOOD VDCDC2:

0 = indicates that the VDCDC2 converter output voltage is below its target regulation voltage or disabled.  
 1 = indicates that the VDCDC2 converter output voltage is within its nominal range.

Bit 2 PGOOD VDCDC3:

0 = indicates that the VDCDC3 converter output voltage is below its target regulation voltage or disabled  
 1 = indicates that the VDCDC3 converter output voltage is within its nominal range.

Bit 1 PGOOD LDO1:

0 = indicates that LDO1 output voltage is below its target regulation voltage or disabled  
 1 = indicates that the LDO1 output voltage is within its nominal range.

Bit 0 PGOOD LDO2:

0 = indicates that the LDO2 output voltage is below its target regulation voltage or disabled.  
 1 = indicates that the LDO2 output voltage is within its nominal range.

### 10.6.12 PGOODMASK. Register Address: 0Ch

PGOODMASK	B7	B6	B5	B4	B3	B2	B1	B0
Bit name and function			MASK VDCDC3 and LDO1	MASK VDCDC1	MASK VDCDC2	MASK VDCDC3	MASKLDO1	MASK LDO2
Default for –70	0	0	0	0	1	0	0	0
Default for -72	0	0	0	1	0	0	0	0
Default for -73, -731, -732	0	0	0	1	1	1	0	0
Set by signal								
Default value loaded by:			UVLO	UVLO	UVLO	UVLO	UVLO	UVLO
Read/write	R	R	R/W	R/W	R/W	R/W	R/W	R/W

#### Bit 5 MASK VDCDC3 and LDO1:

0 = indicates that the output voltage of either DCDC3 or LDO1 is within its nominal range. The PGOOD output is not affected (not driven LOW)

1 = indicates that both LDO1 AND DCDC3 output voltage is below its target regulation voltage or disabled. This will drive the PGOOD output low.

#### Bit 4..0 MASK VDCDC1/2/3, LDO1,2:

0 = the status of the power good Bit in Register PGOOD does not affect the status of the PGOOD output pin

1 = the PGOOD pin is driven low in case the output voltage of the converter or LDO is below its target regulation voltage or disabled.

### 10.6.13 CON\_CTRL1. Register Address: 0Dh

CON_CTRL1	B7	B6	B5	B4	B3	B2	B1	B0
Bit name and function	DCDC_SQ2	DCDC_SQ1	DCDC_SQ0	DCDC1 ENABLE	DCDC2 ENABLE	DCDC3 ENABLE	LDO1 ENABLE	LDO2 ENABLE
Default for –70, –72, –73, –732	See Table 10	See Table 10	See Table 10	1	1	1	1	1
Default for TPS650731	See Table 10	See Table 10	See Table 10	1	1	1	1	0
Set by signal				DCDC1_E NZ	DCDC2_E NZ	DCDC3_EN Z	LDO_ENZ	LDO_ENZ
Default value loaded by:	UVLO	UVLO	UVLO	UVLO	UVLO	UVLO	UVLO	UVLO
Read/write	R/W	R/W	R/W	R/W	R/W	R/W	R/W	R/W

The CON\_CTRL1 register can be used to disable and enable all power supplies through the serial interface. Default is to allow all supplies to be on, providing the relevant enable pin is high. The following tables indicate how the enable pins and the CON\_CTRL1 register are combined. The CON\_CTRL1 Bits are automatically reset to default when the corresponding enable pin is low.

#### Bit 7..5 DCDC\_SQ2 to DCDC\_SQ0: power-up sequencing (power down sequencing is the reverse)

000 = power-up sequencing is: DCDC2 only; DCDC1 and DCDC3 are not part of the automatic sequencing and are enabled by their enable pins EN\_DCDC1 and EN\_DCDC3

001 = power-up sequencing is DCDC2 and DCDC3 at the same time, DCDC1 is not part of the automatic sequencing and is enabled by its enable pin EN\_DCDC1

010 = power-up sequencing is: DCDC1 when power good then DCDC2 and DCDC3 at the same time

011 = power-up sequencing is: DCDC3 when power good then DCDC2; DCDC1 is not part of the automatic sequencing and is controlled by its EN\_DCDC1 pin.

100 = power-up sequencing is: DCDC3 is started at the same time with LDO2 if Bit MASK\_EN\_DCDC3 in register 0Eh is set (default is set). DCDC1 and DCDC2 are started at the same time when LDO2 is PGOOD (defined in LDO sequencing 111); DCDC3 is enabled or disabled with its EN\_DCDC3 pin if MASK\_EN\_DCDC3 in register 0Eh is cleared (set =0). (Sifr PRIMA, start-up from OFF or start-up after SLEEP)

101 = DCDC converters are enabled individually with the external enable pins

110 = DCDC1first, when power good then DCDC2, when power good then DCDC3

111 = power-up sequencing is: DCDC1 and DCDC2 at the same time >1ms after LDO2 has been started (defined in LDO sequencing 010); DCDC3 is not part of the automatic sequencing but is enabled with its EN\_DCDC3 pin (Atlas4)

In case of automatic sequencing other than 101, the start is initiated by going into ON-state. DCDC converters that are not part of the automatic sequencing can be enabled by pulling their enable pin to a logic HIGH level at any time in ON-state. The enable pins for the converters that are automatically enabled, should be tied to GND. For sequencing option DCDC\_SEQ=111, the start is initiated by going into ON-state, however, the external LDO connected to pin EN\_EXTLDO is powered first, followed by LDO2.

(The sequencing of LDO1 and LDO2 is defined in register LDO\_CTRL1.)

Bit 4..0 DCDC1,2,3: See [Table 6](#), [Table 7](#), and [Table 8](#)

**Table 6. DCDC1 Enable Control**

EN_DCDC1 PIN	CON_CTRL1<4>	DCDC1 CONVERTER
0	x	disabled
1	0	disabled
1	1	enabled

**Table 7. DCDC1 Enable Control**

EN_DCDC2 PIN	CON_CTRL1<3>	DCDC2 CONVERTER
0	x	disabled
1	0	disabled
1	1	enabled

**Table 8. DCDC1 Enable Control**

EN_DCDC3 PIN	CON_CTRL1<2>	DCDC3 CONVERTER
0	x	disabled
1	0	disabled
1	1	enabled

**10.6.14 CON\_CTRL2. Register Address: 0Eh**

CON_CTRL2	B7	B6	B5	B4	B3	B2	B1	B0
Bit name and function	ENABLE 1s timer	ENABLE 5s timer	DS_RDY	PWR_DS	MASK_EN_DCDC3	UVLO hysteresis	UVLO1	UVLO0
Default	0	0	0	0	1	1	0	1
Default value loaded by:	UVLO	UVLO	UVLO	UVLO	UVLO	BG_GOOD	BG_GOOD	BG_GOOD
Read/write	R/W	R/W	R/W	R/W	R/W	R/W	R/W	R/W

**Bit 7...6 ENABLE TIMERS:**

0 = the state machine timers of 1 s and 5 s, respectively are disabled  
 1 = the state machine timers of 1 s and 5 s, respectively are enabled

**Bit 5 DS\_RDY (data ready, memory content valid) for use with Sirf Prima processor DEEP SLEEP mode:**

0 = status Bit which is indicating the memory content is not valid after wake up from DEEP SLEEP. This Bit is set / cleared by the Prima application processor. Cleared when device is in UVLO to tell processor there was a power loss. The Bits needs to be cleared by user software after a wake up from DEEP SLEEP to enable the DCDC2 converter to be powered down in shutdown sequencing depending on the status of LDO2.

1 = memory content is valid after wake up from DEEP SLEEP (set by I2C command by application processor only). The Prima processor is ready to power down to DEEP SLEEP mode or was just waking up from DEEP SLEEP mode.

**Bit 4 PWR\_DS (enter DEEP SLEEP for sequencing option DCDC\_SEQ=100, LDO\_SEQ=111):**

0 = PMU is in normal operation

1 = PMU powers down all rails except DCDC2 and the external LDO on pin "EXT\_LDO". PGOOD is pulled LOW.

**Bit 3 MASK\_EN\_DCDC3; used for Prima application processor start-up sequencing:**

0 = DCDC3 is enabled or disabled by the status of EN\_DCDC3 for sequencing option DCDC\_SEQ=100.

1 = DCDC3 will start at the same time with LDO2 for sequencing option DCDC\_SEQ=100. The status of EN\_DCDC3 is ignored

**Bit 2 UNDERVOLTAGE LOCKOUT HYSTERESIS:**

0 = 400-mV hysteresis

1 = 500-mV hysteresis

**Bit 1..0 UVLO1, UVLO2 (undervoltage lockout voltage):**

00 = the device turns off at 2.8 V with the reverse of the sequencing defined in CON\_CTRL1

01 = the device turns off at 3 V with the reverse of the sequencing defined in CON\_CTRL1

10 = the device turns off at 3.1 V with the reverse of the sequencing defined in CON\_CTRL1

11 = the device turns off at 3.25 V with the reverse of the sequencing defined in CON\_CTRL1

Note: The undervoltage lockout voltage is sensed at the SYS pin and the device goes to OFF state when the voltage is below the value defined in the register. BG\_GOOD is the internal bandgap good signal which occurs at lower voltages than UVLO.

### 10.6.15 CON\_CTRL3. Register Address: 0Fh

CON_CTRL3	B7	B6	B5	B4	B3	B2	B1	B0
Bit name and function	FPWM DCDC3	FPWM DCDC2	FPWM DCDC1	DCDC1 discharge	DCDC2 discharge	DCDC3 discharge	LDO1 discharge	LDO2 discharge
Default	0	0	0	1	1	1	1	1
Default value loaded by:	UVLO	UVLO	UVLO	UVLO	UVLO	UVLO	UVLO	UVLO
Read/write	R/W	R/W	R/W	R/W	R/W	R/W	R/W	R/W

- Bit 7           FPWM DCDC3:  
 0 = DCDC3 converter operates in PWM / PFM mode  
 1 = DCDC3 converter is forced into fixed frequency PWM mode
- Bit 6           FPWM DCDC2:  
 0 = DCDC2 converter operates in PWM / PFM mode  
 1 = DCDC2 converter is forced into fixed frequency PWM mode
- Bit 5           FPWM DCDC1:  
 0 = DCDC1 converter operates in PWM / PFM mode  
 1 = DCDC1 converter is forced into fixed frequency PWM mode
- Bit 4–0        0 = the output capacitor of the associated converter or LDO is not actively discharged when the converter or LDO is disabled  
 1 = the output capacitor of the associated converter or LDO is actively discharged when the converter or LDO is disabled. This decreases the fall time of the output voltage at light load

### 10.6.16 DEFDCDC1. Register Address: 10h

DEFDCDC1	B7	B6	B5	B4	B3	B2	B1	B0
Bit name and function	DCDC1 extadj		DCDC1[5]	DCDC1[4]	DCDC1[3]	DCDC1[2]	DCDC1[1]	DCDC1[0]
Default for –70, –72	0	0	1	1	1	1	1	1
Default for –73, –731, –732	0	0	1	0	0	1	0	1
Default value loaded by:	UVLO	UVLO	UVLO	UVLO	UVLO	UVLO	UVLO	UVLO
Read/write	R/W	R	R/W	R/W	R/W	R/W	R/W	R/W

DEFDCDC1 sets the output voltage for the DCDC1 converter. Per default the converter is internally fixed but can be programmed to an externally adjustable version by setting Bit 7 (Ext adj). The default setting is defined in an EEPROM Bit. In case the externally adjustable version is programmed, the external resistor divider need to be connected to the VDCDC1 pin, otherwise this pin needs to be connected to the output voltage directly. For the fixed voltage version, the output voltage is set with Bits B0 to B5 (DCDC1[5] to DCDC1[0]):

All step-down converters provide the same output voltage range, see [DEFDCDC3\\_LOW](#). Register Address: 13h.

**10.6.17 DEFDCDC2\_LOW. Register Address: 11h**

DEFDCDC2_LOW	B7	B6	B5	B4	B3	B2	B1	B0
Bit name and function			DCDC2[5]	DCDC2[4]	DCDC2[3]	DCDC2[2]	DCDC2[1]	DCDC2[0]
Default for -70, -72, -732	0	0	1	0	0	1	0	1
Default for -73, -731	0	0	0	1	0	0	1	1
Default value loaded by:			UVLO	UVLO	UVLO	UVLO	UVLO	UVLO
Read/write	R	R	R/W	R/W	R/W	R/W	R/W	R/W

**10.6.18 DEFDCDC2\_HIGH. Register Address: 12h**

DEFDCDC2_HIGH	B7	B6	B5	B4	B3	B2	B1	B0
Bit name and function	DCDC2 extadj		DCDC2[5]	DCDC2[4]	DCDC2[3]	DCDC2[2]	DCDC2[1]	DCDC2[0]
Default -70, -732	0	0	1	1	1	1	1	1
Default for -72	0	0	1	1	0	0	1	1
Default for -73, -731	0	0	1	0	0	1	0	1
Default value loaded by:	UVLO		UVLO	UVLO	UVLO	UVLO	UVLO	UVLO
Read/write	R/W	R	R/W	R/W	R/W	R/W	R/W	R/W

The output voltage for DCDC2 is switched between the value defined in DEFDCDC2\_LOW and DEFDCDC2\_HIGH depending on the status of the DEFDCDC2 pin. IF DEFDCDC2 is LOW the value in DEFDCDC2\_LOW is selected, if DEFDCDC2 = HIGH, the value in DEFDCDC2\_HIGH is selected. Per default the converter is internally fixed but can be programmed to an externally adjustable version by EEPROM similar to DCDC1.

**10.6.19 DEFDCDC3\_LOW. Register Address: 13h**

DEFDCDC3_LOW	B7	B6	B5	B4	B3	B2	B1	B0
Bit name and function			DCDC3[5]	DCDC3[4]	DCDC3[3]	DCDC3[2]	DCDC3[1]	DCDC3[0]
Default for -70	0	0	0	0	1	0	1	1
Default for -72, -73, -731, -732	0	0	0	1	0	0	1	1
Default value loaded by:			UVLO	UVLO	UVLO	UVLO	UVLO	UVLO
Read/write	R/W	R	R/W	R/W	R/W	R/W	R/W	R/W

**10.6.20 DEFDCDC3\_HIGH. Register Address: 14h**

DEFDCDC3_HIGH	B7	B6	B5	B4	B3	B2	B1	B0
Bit name and function	DCDC3 extadj		DCDC3[5]	DCDC3[4]	DCDC3[3]	DCDC3[2]	DCDC3[1]	DCDC3[0]
Default -70	0	0	0	1	0	0	1	1
Default for -72	0	0	0	1	1	0	1	1
Default for -73, -731, -732	0	0	0	1	1	0	0	1
Default value loaded by:	UVLO		UVLO	UVLO	UVLO	UVLO	UVLO	UVLO
Read/write	R/W	R	R/W	R/W	R/W	R/W	R/W	R/W

The output voltage for DCDC3 is switched between the value defined in DEFDCDC3\_LOW and DEFDCDC3\_HIGH depending on the status of the DEFDCDC3 pin. IF DEFDCDC3 is LOW the value in DEFDCDC3\_LOW is selected, if DEFDCDC3 = HIGH, the value in DEFDCDC3\_HIGH is selected. Per default the converter is internally fixed but can be programmed to an externally adjustable version by EEPROM similar to DCDC2.

**Table 9. DCDC Output Voltage Range**

OUTPUT VOLTAGE [V]	B5	B4	B3	B2	B1	B0
0.725	0	0	0	0	0	0
0.750	0	0	0	0	0	1
0.775	0	0	0	0	1	0
0.800	0	0	0	0	1	1
0.825	0	0	0	1	0	0
0.850	0	0	0	1	0	1
0.875	0	0	0	1	1	0
0.900	0	0	0	1	1	1
0.925	0	0	1	0	0	0
0.950	0	0	1	0	0	1
0.975	0	0	1	0	1	0
1.000	0	0	1	0	1	1
1.025	0	0	1	1	0	0
1.050	0	0	1	1	0	1
1.075	0	0	1	1	1	0
1.100	0	0	1	1	1	1
1.125	0	1	0	0	0	0
1.150	0	1	0	0	0	1
1.175	0	1	0	0	1	0
1.200	0	1	0	0	1	1
1.225	0	1	0	1	0	0
1.250	0	1	0	1	0	1
1.275	0	1	0	1	1	0
1.300	0	1	0	1	1	1
1.325	0	1	1	0	0	0
1.350	0	1	1	0	0	1
1.375	0	1	1	0	1	0
1.400	0	1	1	0	1	1
1.425	0	1	1	1	0	0
1.450	0	1	1	1	0	1
1.475	0	1	1	1	1	0
1.500	0	1	1	1	1	1

**Table 9. DCDC Output Voltage Range (continued)**

OUTPUT VOLTAGE [V]	B5	B4	B3	B2	B1	B0
1.550	1	0	0	0	0	0
1.600	1	0	0	0	0	1
1.650	1	0	0	0	1	0
1.700	1	0	0	0	1	1
1.750	1	0	0	1	0	0
1.800	1	0	0	1	0	1
1.850	1	0	0	1	1	0
1.900	1	0	0	1	1	1
1.950	1	0	1	0	0	0
2.000	1	0	1	0	0	1
2.050	1	0	1	0	1	0
2.100	1	0	1	0	1	1
2.150	1	0	1	1	0	0
2.200	1	0	1	1	0	1
2.250	1	0	1	1	1	0
2.300	1	0	1	1	1	1
2.350	1	1	0	0	0	0
2.400	1	1	0	0	0	1
2.450	1	1	0	0	1	0
2.500	1	1	0	0	1	1
2.550	1	1	0	1	0	0
2.600	1	1	0	1	0	1
2.650	1	1	0	1	1	0
2.700	1	1	0	1	1	1
2.750	1	1	1	0	0	0
2.800	1	1	1	0	0	1
2.850	1	1	1	0	1	0
2.900	1	1	1	0	1	1
3.000	1	1	1	1	0	0
3.100	1	1	1	1	0	1
3.200	1	1	1	1	1	0
3.300	1	1	1	1	1	1

### 10.6.21 DEFSLEW. Register Address: 15h

DEFSLEW	B7	B6	B5	B4	B3	B2	B1	B0
Bit name and function						SLEW2	SLEW1	SLEW0
Default	0	0	0	0	0	1	1	0
Default value loaded by:						UVLO	UVLO	UVLO
Read/write	R	R	R	R	R	R/W	R/W	R/W

The DEFSLEW register defines the slew rate of the output voltage for DCDC2 and DCDC3 in case the voltage is changed during operation. In case Bit “LDO2 tracking” in register DEFLDO2 is set, this is also valid for LDO2. When the voltage change is initiated by toggling pin DEFDCDC2 or DEFDCDC3, the start of the voltage change is triggered by the rising or falling edge of the DEFDCDC2 or DEFDCDC3 pin. If a voltage change is done internally by re-programming register DEFDCDC2\_LOW, DEFDCDC2\_HIGH, DEFDCDC3\_LOW or DEFDCDC3\_HIGH, the voltage change is initiated immediately after the new value has been written to the register with the slew rate defined.

SLEW2	SLEW1	SLEW0	VDCDC3 SLEW RATE
0	0	0	0.11 mV/μs
0	0	1	0.22 mV/μs
0	1	0	0.45 mV/μs
0	1	1	0.9 mV/μs
1	0	0	1.8 mV/μs
1	0	1	3.6 mV/μs
1	1	0	7.2 mV/μs
1	1	1	Immediate

### 10.6.22 LDO\_CTRL1. Register Address: 16h

LDO_CTRL1	B7	B6	B5	B4	B3	B2	B1	B0
Bit name and function	LDO_SQ2	LDO_SQ1	LDO_SQ0		LDO1[3]	LDO1[2]	LDO1[1]	LDO1[0]
Default for –70	See Table 10	See Table 10	See Table 10	0	1	0	0	1
Default for –73, –731, –732,	See Table 10	See Table 10	See Table 10	0	1	0	0	1
Default for –72	See Table 10	See Table 10	See Table 10	0	0	0	1	0
Default value loaded by:	UVLO	UVLO	UVLO		UVLO	UVLO	UVLO	UVLO
Read/write	R/W	R/W	R/W	R	R/W	R/W	R/W	R/W

Bit 7..5 LDO\_SQ2 to LDO\_SQ0: power-up sequencing: (power down sequencing is the reverse)

000 = LDO1 and LDO2 are enabled as soon as device is in ON-state by pulling  $\overline{\text{PB\_IN}}=\text{LOW}$  or  $\text{POWER\_ON}=\text{HIGH}$

001 = LDO1 and LDO2 are enabled after DCDC3 was enabled and its power good Bit is high.

010 = external pin at “EN\_EXTLDO” is driven HIGH first, after >1ms LDO2 is enabled, LDO1 is enabled at the same time with DCDC3. EN\_EXTLDO is driven LOW by going into OFF-state, LDO2 is disabled at the same time with EN\_EXTLDO going LOW. Disabling LDO2 in register CON\_CTRL1 will not drive EN\_EXTLDO=LOW. (Atlas4)

011 = LDO1 is enabled 300us after PGOOD of DCDC1, LDO2 is off. LDO2 can be enabled/disabled by an I2C command in register CON\_CTRL1.

100 = LDO1 is enabled after DCDC1 shows power good; LDO2 is enabled with DCDC3

101 = LDO1 is enabled with DCDC2; LDO2 is enabled after DCDC1 is enabled and its power good Bit is high

110 = LDO1 is enabled 10ms after DCDC2 is enabled and its power good Bit is high, LDO2 is off. LDO2 can be enabled / disabled by an I2C command in register CON\_CTRL1.

111 = external pin at EN\_EXTLDO is driven HIGH first, after >1ms LDO2 is enabled, LDO1 is enabled when EN\_DCDC3 pin is pulled high AND DCDC3 is power good (first power-up from OFF state). LDO1 is disabled when EN\_DCDC3 pin goes LOW for SLEEP mode. LDO2 is disabled at the same time with DCDC2 and DCDC1 during shutdown (Sirf PRIMA).

Automatic sequencing sets the enable Bits of the LDOs accordingly, so the LDOs can be enabled or disabled by the I2C interface in ON-state.

All sequencing options that define a ramp in sequence for the DC-DC converters and the LDOs, (not at the same time) are timed such that the power good signal triggers the start for the next converter. If there is a time defined such as 1-ms delay, the timer is started after the power good signal of the previous converter is high. LDO enable is delayed by 170  $\mu\text{s}$  internally to match the delay for the DC-DC converters. By this, for sequencing options that define a ramp at the same time for an LDO and a DC-DC converter, it is made sure they will ramp at the same time, given the fact the DC-DC converters have an internal 170- $\mu\text{s}$  delay as well.

Bit 3..0 LDO1(3) to LDO1(0):

The Bits define the default output voltage of LDO1 according to the table below:

LDO1[3]	LDO1[2]	LDO1[1]	LDO1[0]	LDO1 OUTPUT VOLTAGE
0	0	0	0	1.0 V
0	0	0	1	1.1 V
0	0	1	0	1.2 V
0	0	1	1	1.25 V
0	1	0	0	1.3 V
0	1	0	1	1.35 V
0	1	1	0	1.4 V
0	1	1	1	1.5 V
1	0	0	0	1.6 V
1	0	0	1	1.8 V
1	0	1	0	2.5 V
1	0	1	1	2.75 V
1	1	0	0	2.8 V
1	1	0	1	3.0 V
1	1	1	0	3.1 V
1	1	1	1	3.3 V

### 10.6.23 DEFLDO2. Register Address: 17h

DEFLDO2	B7	B6	B5	B4	B3	B2	B1	B0
Bit name and function		LDO2 tracking	LDO2[5]	LDO2[4]	LDO2[3]	LDO2[2]	LDO2[1]	LDO2[0]
Default for –70, –72	0	0	0	1	0	0	1	1
Default for –73, –731, –732	0	0	1	0	0	1	0	1
Default value loaded by:		UVLO	UVLO	UVLO	UVLO	UVLO	UVLO	UVLO
Read/write	R	R/W	R/W	R/W	R/W	R/W	R/W	R/W

The DEFLDO2 register is used to set the output voltage of LDO2 according to the voltage table defined under DEFDCDC3 when Bit LDO2 tracking is set to 0. In case Bit LDO2 tracking is set to 1, the output voltage of LDO2 is defined by the contents defined for DCDC3.

Bit 6 LDO2 TRACKING:

0 = the output voltage is defined by register DEFLDO2

1 = the output voltage follows the setting defined for DCDC3 (DEFDCDC3\_LOW or DEFDCDC3\_HIGH, depending on the state of pin DEFDCDC3)

Bit 5..0 LDO2[5] to LDO2[0]:

output voltage setting for LDO2 similar to DCDC3

**10.6.24 WLED\_CTRL1. Register Address: 18h**

WLED_CTRL1	B7	B6	B5	B4	B3	B2	B1	B0
Bit name and function	Enable ISINK		Dimming frequency1	Dimming frequency0				
Default	0	0	0	1	0	0	0	0
Default value loaded by:	UVLO		UVLO	UVLO				
Read/write	R/W	R	R/W	R/W	R	R	R	R

Bit 7      **ENABLE ISINK:**  
 0 = both current sinks are turned OFF, the wLED boost converter is disabled  
 1 = both current sinks are turned on, the wLED boost converter is enabled

Bit 5..4    **DIMMING FREQUENCY 0/1:**  
 00 = 100 Hz  
 01 = 200 Hz  
 10 = 500 Hz  
 11 = 1000 Hz

**10.6.25 WLED\_CTRL2. Register Address: 19h**

WLED_CTRL2	B7	B6	B5	B4	B3	B2	B1	B0
Bit name and function	Current level	LED DUTY CYCLE_6	LED DUTY CYCLE_5	LED DUTY CYCLE_4	LED DUTY CYCLE_3	LED DUTY CYCLE_2	LED DUTY CYCLE_1	LED DUTY CYCLE_0
Default	0	0	0	1	1	1	1	0
Default value loaded by:	UVLO	UVLO	UVLO	UVLO	UVLO	UVLO	UVLO	UVLO
Read/write	R/W	R/W	R/W	R/W	R/W	R/W	R/W	R/W

Bit 7      **CURRENT LEVEL:**  
 0 = current defined with resistor connected from ISET2 to GND  
 1 = current defined with resistor connected from ISET1 to GND

Bit 6..0    sets the duty cycle for PWM dimming from 1% (000000) to 100% (1100011).  
 Values above 1100011 set the duty cycle to 0 %; default is 30% duty cycle

## 11 Application and Implementation

### NOTE

Information in the following applications sections is not part of the TI component specification, and TI does not warrant its accuracy or completeness. TI's customers are responsible for determining suitability of components for their purposes. Customers should validate and test their design implementation to confirm system functionality.

### 11.1 Application Information

The TPS6507x is designed to pair with various application processors. This section describes how use the TPS6507x for an application and provides some examples for designing for certain applications and processors including OMAP-L138, OMAP35xx, AM3505, and Atlas IV.

#### 11.1.1 Power Solutions For Different Application Processors

##### 11.1.1.1 Default Settings

For proper power supply design with TPS6507x, not only the default output voltage is relevant but also in what sequence the different power rails are enabled. The voltages are typically enabled internally based on the sequencing options programmed. For different application processors, there are different sequencing options available. In addition, the delay time and pulse for the reset signal to the application processor is different. See [Table 10](#) with the default settings for sequencing, output voltages and reset options for the TPS6507x family:

**Table 10. Sequencing Settings**

PART NUMBER	DEDICATED FOR	DCDC_SQ[2..0]	LDO_SQ[2..0]	COMMENT
TPS65070	OMAP-L138	011	001	DCDC1= I/O, (3.3 V); enabled by EN_DCDC1 DCDC2= DVDD3318 (1.8 V or 3.3 V) (DEFDCDC2=LOW: 1.8 V; DEFDCDC2=HIGH: 3.3 V) DCDC3=core voltage CVDD (DEFDCDC3=LOW: 1 V; DEFDCDC3=HIGH: 1.2 V) LDO1= 1.8 V, delayed by external PMOS LDO2= 1.2 V PGOOD delay time (reset delay): 400ms <PGOODMASK>=08h: reset based on VDCDC2
TPS65072	Sirf Atlas 4	111	010	DCDC1=VDDIO (3.3 V) DCDC2=VMEM (1.8 V) DCDC3= VDD_PDN (1.2 V) driven by X_PWR_EN LDO1=VDD_PLL (1.2 V) LDO2=VDD_PRE (1.2 V) EN_EXTLDO=VDDIO_RTC PGOOD delay time (reset delay): 20 ms <PGOODMASK>=10h: reset based on VDCDC1
TPS65073	OMAP3503 OMAP3515 OMAP3525 OMAP3530	101 Supporting SYS-OFF mode	001	Supporting SYS-OFF mode: DCDC1=VDDS_WKUP_BG, VDDS_MEM, VDDS, VDDS_SRAM (1.8 V) DCDC2=VDDCORE (1.2 V) DCDC3=VDD_MPU_IVA (1.2 V) LDO1= VDDS_DPLL_DLL, VDDS_DPLL_PER (1.8 V) LDO2=VDDS_MM1 (1.8 V) PGOOD delay time (reset delay): 400 ms <PGOODMASK>=1Ch: based on VDCDC1, VDCDC2, VDCDC3

**Application Information (continued)**
**Table 10. Sequencing Settings (continued)**

PART NUMBER	DEDICATED FOR	DCDC_SQ[2..0]	LDO_SQ[2..0]	COMMENT
TPS650731	OMAP35xx	110	011	DCDC1=VDDS_WKUP_BG, VDDS_MEM, VDDS, VDDS_SRAM (1.8 V) DCDC2=VDDCORE (1.2 V) DCDC3=VDD_MPU_IVA (1.2 V) LDO1=VDDS_DPLL_DLL (1.8 V) LDO2=VDDA_DAC (1.8 V): OFF, enabled by I2C PGOOD delay time (reset delay): 400 ms <PGOODMASK>=1Ch: reset based on VDCDC1, VDCDC2, VDCDC3
TPS650732	AM3505 AM3517	110	001	DCDC1=VDDS1-5 (1.8 V) DCDC2=VDDSHV (3.3 V) DCDC3=VDD_CORE (1.2 V) LDO1=VDDA1P8V (1.8 V) LDO2=VDDS_DPLL (1.8 V) PGOOD delay time (reset delay): 400 ms <PGOODMASK>=1Ch: reset based on VDCDC1, VDCDC2, VDCDC3

**11.1.1.2 Starting TPS6507x**

TPS6507x was developed for battery powered applications with focus on lowest shutdown and quiescent current. To achieve this, in shutdown all mayor blocks and the system voltage at the output of the power path (SYS) are turned off and only the input that turns on TPS6507x, pin PB\_IN, is supervised. TPS6507x is designed such that only an ON-key on PB\_IN is needed pulling this pin LOW to enable TPS6507x. No external pullup is needed as this is integrated into TPS6507x.

Once PB\_IN is pulled LOW, the system voltage is ramped and the DC-DC converters and LDOs are started with the sequencing defined for the version used. If PB\_IN is released again, TPS6507x would turn off, so a pin was introduced to keep TPS6507x enabled after PB\_IN was released. Pin POWER\_ON serves this function and needs to be pulled HIGH before the user releases the ON-key (PB\_IN = HIGH). This HIGH signal at POWER\_ON can be provided by the GPIO of a processor or by a pullup resistor to any voltage in the system which is higher than 1.2 V. Pulling POWER-ON to a supply voltage would significantly reduce the time PB\_IN has to be asserted LOW. If POWER\_ON is tied to a GPIO, the processor has to boot up first which may take some time. In this case however, the processor could do some additional debouncing, hence does not keep the power enabled if the ON-key is only pressed for a short time. When there is a supply voltage for the battery charger at pins AC or USB, the situation is slightly different. In this case, the power path is enabled and the system voltage (SYS) has ramped already to whatever the voltage at AC or USB is. The dcdc converters are not enabled yet but the start-up could not only be done by pulling PB\_IN=LOW but also by pulling POWER\_ON=HIGH.

In applications that do not require an ON-key but shall power-up automatically once supply voltage is applied, there are two cases to consider. If TPS6507x is powered from its AC or USB pin (not powered from its BAT pin), POWER-ON just needs to be pulled HIGH to enable the converters. PB\_IN must not be tied LOW in this case.

If TPS6507x is powered from its BAT pin, PB\_IN needs to be tied LOW to start up the converters.

## 11.2 Typical Applications

### 11.2.1 General PMIC Application

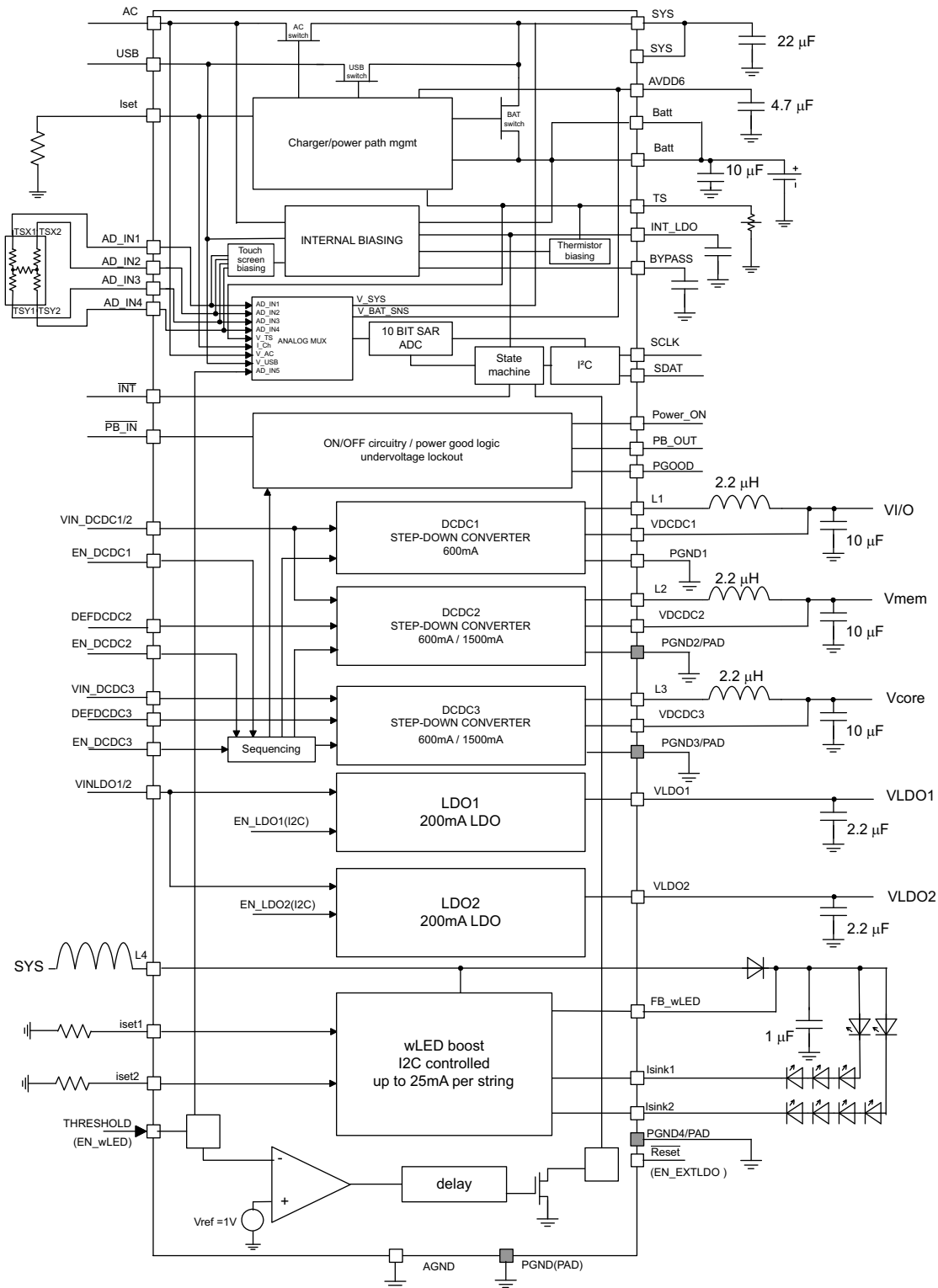

Copyright © 2016, Texas Instruments Incorporated

Figure 45. Application Schematic for TPS65070x

## Typical Applications (continued)

### 11.2.1.1 Design Requirements

All converters and LDOs must have appropriate output filters or be terminated properly. The device also includes a battery charger, wLEDs, and digital logic signals for PGOODs and RESETs.

### 11.2.1.2 Detailed Design Procedure

#### 11.2.1.2.1 Output Filter Design (Inductor and Output Capacitor)

##### 11.2.1.2.1.1 Inductor Selection

The step-down converters operate typically with 2.2-μH output inductor. Larger or smaller inductor values can be used to optimize the performance of the device for specific operation conditions. The selected inductor has to be rated for its DC resistance and saturation current. The DC resistance of the inductance will influence directly the efficiency of the converter. Therefore an inductor with lowest DC resistance should be selected for highest efficiency.

[Equation 4](#) can be used to calculate the maximum inductor current under static load conditions. The saturation current of the inductor should be rated higher than the maximum inductor current as calculated with [Equation 4](#). This is recommended because during heavy load transient the inductor current will rise above the calculated value.

$$\Delta I_L = V_{out} \times \frac{1 - \frac{V_{out}}{V_{in}}}{L \times f} \quad (4)$$

$$I_{Lmax} = I_{outmax} + \frac{\Delta I_L}{2}$$

where

- f = Switching Frequency (2.25 MHz typical)
- L = Inductor Value
- ΔI<sub>L</sub> = Peak to Peak inductor ripple current
- I<sub>Lmax</sub> = Maximum Inductor current

The highest inductor current will occur at maximum V<sub>in</sub>.

Open core inductors have a soft saturation characteristic and they can usually handle higher inductor currents versus a comparable shielded inductor.

A more conservative approach is to select the inductor current rating just for the maximum switch current of the corresponding converter. It must be considered, that the core material from inductor to inductor differs and will have an impact on the efficiency especially at high switching frequencies.

Refer to [Table 11](#) and the typical applications for possible inductors.

**Table 11. Tested Inductors**

INDUCTOR TYPE	RECOMMENDED MAXIMUM DC CURRENT	INDUCTOR VALUE	SUPPLIER
LPS3010	0.6 A	2.2 μH	Coilcraft
LPS3015	1.2 A	2.2 μH	Coilcraft
LPS4018	1.5 A	2.2 μH	Coilcraft
VLCF4020	1.5 A	2.2 μH	TDK

##### 11.2.1.2.1.2 Output Capacitor Selection

The advanced Fast Response voltage mode control scheme of the two converters allow the use of small ceramic capacitors with a typical value of 10μF, without having large output voltage under and overshoots during heavy load transients. Ceramic capacitors having low ESR values result in lowest output voltage ripple and are therefore recommended. Please refer to for recommended components.

If ceramic output capacitors are used, the capacitor RMS ripple current rating will always meet the application requirements. Just for completeness the RMS ripple current is calculated as:

$$I_{\text{RMS}C_{\text{out}}} = V_{\text{out}} \times \frac{1 - \frac{V_{\text{out}}}{V_{\text{in}}}}{L \times f} \times \frac{1}{2 \times \sqrt{3}} \quad (6)$$

At nominal load current the inductive converters operate in PWM mode and the overall output voltage ripple is the sum of the voltage spike caused by the output capacitor ESR plus the voltage ripple caused by charging and discharging the output capacitor:

$$\Delta V_{\text{out}} = V_{\text{out}} \times \frac{1 - \frac{V_{\text{out}}}{V_{\text{in}}}}{L \times f} \times \left( \frac{1}{8 \times C_{\text{out}} \times f} + \text{ESR} \right) \quad (7)$$

Where the highest output voltage ripple occurs at the highest input voltage  $V_{\text{in}}$ .

At light load currents the converters operate in Power Save Mode and the output voltage ripple is dependent on the output capacitor value. The output voltage ripple is set by the internal comparator delay and the external capacitor. The typical output voltage ripple is less than 1% of the nominal output voltage.

#### 11.2.1.2.1.3 Input Capacitor Selection/Input Voltage

Because of the nature of the buck converter having a pulsating input current, a low ESR input capacitor is required for best input voltage filtering and minimizing the interference with other circuits caused by high input voltage spikes. The converters need a ceramic input capacitor of 10  $\mu\text{F}$ . The input capacitor can be increased without any limit for better input voltage filtering.

The input voltage for the step-down converters needs to be connected to pin VINDCDC1/2 for DCDC1 and DCDC2 and to pin VINDCDC3 for DCDC3. These pins need to be tied together to the power source on pin SYS (output of the power path). The 3 step-down converters must not be supplied from different input voltages.

**Table 12. Possible Capacitors**

CAPACITOR VALUE	CASE SIZE	MANUFACTURER AND PART NUMBER	TYPE
22 $\mu\text{F}$	0805	TDK C2012X5R0J226MT	Ceramic
22 $\mu\text{F}$	0805	Taiyo Yuden JMK212BJ226MG	Ceramic
10 $\mu\text{F}$	0805	Taiyo Yuden JMK212BJ106M	Ceramic
10 $\mu\text{F}$	0805	TDK C2012X5R0J106M	Ceramic

#### 11.2.1.2.1.4 Output Voltage Selection

The DEFDCDC2 and DEFDCDC3 pins are used to set the output voltage for step-down converter DCDC2 and DCDC3. See [Table 2](#) for the default voltages if the pins are pulled to GND or to  $V_{\text{cc}}$ .

#### 11.2.1.2.1.5 Voltage Change on DCDC2 and DCDC3

The output voltage of DCDC2 and DCDC3 can be changed during operation from, for example, 1 V to 1.2 V (TPS65070) and back by toggling the DEFDCDC2 or DEFDCDC3 pin. The status of the DEFDCDC3 pin is sensed during operation and the voltage is changed as soon as the logic level on this pin changes from low to high or vice versa.

The output voltage for DCDC2 and DCDC3 can also be changed by changing the register content in registers DEFDCDC2\_LOW, DEFDCDC2\_HIGH, DEFDCDC3\_LOW and DEFDCDC3\_HIGH.

### 11.2.1.2.2 LDOs

#### 11.2.1.2.2.1 Output Capacitor Selection

The control loop of the LDOs is compensated such that it requires a minimum of 2.2  $\mu\text{F}$  as an output capacitor. Ceramic X5R or X7R capacitors should be used.

### 11.2.1.2.2.2 Input Capacitor Selection

The input voltage for the two LDOs should be bypassed by a ceramic capacitor of 2.2  $\mu\text{F}$  minimum.

### 11.2.1.2.2.3 Output Voltage Change For LDO1 and LDO2

The output voltage of LDO1 and LDO2 is defined in registers LDO\_CTRL1 for LDO1 and in register DEF\_LDO2 for LDO2. The output voltage can be changed in these registers after power-up.

### 11.2.1.2.2.4 Unused LDOs

In case both LDOs are unused, connect VINLDO1/2 to the SYS node. If VINLDO1/2 is tied to GND, the SYS voltage will not be turned off during a power-down with only a battery connected and a transit to ON-state is not possible afterwards.

### 11.2.1.2.3 White-LED Boost Converter

#### 11.2.1.2.3.1 LED-Current Setting/Dimming

The white LED boost converter generates an output voltage, high enough to drive current through up to 10 white LEDs connected in series. TPS6507x support one or two strings of white LEDs. If two strings of white LEDs are used, the number of LEDs in each string is limited to 6 LEDs due to the switch current limit as defined in the electrical characteristics. The boost converter block contains two current sinks to control the current through the white LEDs. The anodes of the “upper” white-LEDs are directly connected to the output voltage at the output capacitor. The cathode of the “lowest” LED is connected to the input of the current sink at pin ISINK1 or ISINK2. The internal current sink controls the output voltage of the boost converter such that there is a minimum voltage at the current sink to regulate the defined current. The maximum current is set with a resistor connected from pin ISET1 to GND. Dimming is done with an internal PWM modulator by changing the duty cycle in the current sinks from 1% to 100%. In order to set a LED current of less than 1% of the current defined at ISET1, a second current range is set with a resistor at pin ISET2 to GND. By changing between the two current ranges and varying the duty cycle, it is possible to achieve a dimming ratio of > 1:100. The main functions of the converter like enable / disable of the converter, PWM duty cycle and dimming frequency are programmed in registers WLED\_CTRL1 and WLED\_CTRL2 – see the register description for details.

If only one string of white LEDs are used, ISINK1 and ISINK2 need to be connected in parallel.

#### 11.2.1.2.3.2 Setup

In applications not requiring the wLED boost converter, the pins should be tied to a GND as stated below:

Pins L4, FB\_wLED, ISINK1 and ISINK2 should be directly connected to GND. Each ISET1 and ISET2 should be connected to GND with a 100-k $\Omega$  resistor. Optionally ISET1 and ISET2 can be used as analog inputs to the ADC. In this case, these pins can be tied to a voltage source in the range from 0 V to 2.25 V.

#### 11.2.1.2.3.3 Setting the LED Current

There are two resistors which set the default current for the current sinks at ISINK1 and ISINK2.

The resistor connected to ISET1 is used if Bit CURRENT LEVEL is set 1 in register 19h.

The resistor connected to ISET2 is used if Bit CURRENT LEVEL is set 0 in register 19h (default).

This allows switching between two different maximum values for the LED current with one Bit to extend the resolution for dimming.

Dimming is done by an internal PWM signal that turns on and off the current sinks ISINK1 and ISINK2 at 200Hz (default). The duty cycle range is 1% to 100% with a 1% resolution and a default duty cycle of 30%. In order to get the full scale LED current, the PWM dimming needs to be set to 100% in register 19h. This is done by writing 63h to register 19h.

$K_{\text{ISET}}$  is defined to be 1000 in the electrical spec, the reference voltage at ISET1 and ISET2 is 1.24 V.

The current for each string is set by the resistor to:

$$\text{ISINK1}=\text{ISINK2}= K_{\text{ISET}} \times 1.24\text{V}/R_{\text{ISET}x} \quad (8)$$

$$R_{\text{ISET}1}, R_{\text{ISET}2} = K_{\text{ISET}} \times 1.24\text{V}/10\text{mA}=124 \text{ k}\Omega \quad (9)$$

A resistor value of 124 k $\Omega$  sets the current on each string to 10 mA.

For one string of wLEDs, both strings need to be connected in parallel, so the current in the wLEDs is twice the current programmed by the resistor at ISET1 or ISET2.

Connecting both strings in parallel is required because the wLED converter generates its output voltage dependant on the current in ISINK1 and ISINK2. If the current falls below the target, the output voltage is increased. If one string is open, the wLED driver will boost the output voltage to its maximum because it assumes the voltage is not high enough to drive current into this string (there could be different numbers of wLEDs in the two strings).

#### 11.2.1.2.3.4 Inductor Selection

The inductor in a boost converter serves as an energy storage element. The energy stored equals  $\frac{1}{2} L \times I^2$ . Therefore, the inductor must not be saturated as the inductance will drop and the energy stored will be reduced causing bad efficiency. The converter operates with typically 15- $\mu$ H to 22- $\mu$ H inductors. A design example for an application powering 6LEDs in one string given below:

- $V_{in} = 2.8 \text{ V}$  — minimum input voltage for the boost converter
- $V_o = 6 \times 3.2 \text{ V} = 19.2 \text{ V}$  — assuming a forward voltage of 3.2 V per LED
- $V_f = 0.5 \text{ V}$  — forward voltage of the Schottky diode
- $I_o = 25 \text{ mA}$  maximum LED current
- $F_{sw} = 1.125 \text{ MHz}$  — switching frequency —  $T = 890 \text{ ns}$
- $R_{ds(on)} = 0.6 \Omega$  — drain-source resistance of the internal NMOS switch
- $V_{sw}$  — voltage drop at the internal NMOS switch
- $I_{AVG}$  — average current in NMOS when turned on

The duty cycle for a boost converter is:

$$D = \frac{V_o + V_f - V_{in}}{V_o + V_f - V_{sw}} \quad (10)$$

With:

$$V_{sw} = R_{ds(on)} \times I_{AVG} \quad I_{avg} = \frac{I_o}{1 - D} \quad (11)$$

A different approach to calculate the duty cycle is based on the efficiency of the converter. The typical number can be found in the graphs, or as a first approach, we can assume to get an efficiency of about 80% as a typical value.

$$D \approx \left( 1 - \eta \times \frac{V_i}{V_o + V_f} \right) \quad (12)$$

With the values given above

$$D \approx \left( 1 - 0.8 \frac{2.8 \text{ V}}{19.2 \text{ V} + 0.5 \text{ V}} \right) \approx 89\% \quad (13)$$

$$t_{on} = T \times D = 890 \text{ ns} \times 0.89 = 792 \text{ ns}$$

$$t_{off} = 890 \text{ ns} - 792 \text{ ns} = 98 \text{ ns}$$

$$V_{sw} = R_{ds(on)} \times I_{AVG} = R_{ds(on)} \times \frac{I_o}{1 - D} = 0.6 \Omega \times \frac{25 \text{ mA}}{1 - 0.89} \approx 140 \text{ mV} \quad (14)$$

When the NMOS switch is turned on, the input voltage is forcing a current into the inductor. The current slope can be calculated with:

$$di = \frac{V_L \times dt}{L} = \frac{(V_{in} - V_{sw}) \times dt}{L} = \frac{(2.8 \text{ V} - 0.14 \text{ V}) \times 792 \text{ ns}}{18 \mu\text{H}} = 117 \text{ mA} \quad (15)$$

$$I_{avg} = \frac{I_o}{1 - D} = \frac{25 \text{ mA}}{1 - 0.89} = 227 \text{ mA} \quad (16)$$

The minimum and maximum inductor current can be found by adding half of the inductor current ripple (di) to the average value, which gives:

$$I_{max} = 227 \text{ mA} + \frac{117 \text{ mA}}{2} = 285 \text{ mA}$$

$$I_{min} = 227 \text{ mA} - \frac{117 \text{ mA}}{2} = 169 \text{ mA}$$

(17)

Given the values above, an inductor with a current rating greater than 290 mA is needed. Plenty of margin should be kept to the rating in the inductor vendors data sheets as the maximum current is typically specified at a inductance drop of 20% or even 30%. A list of tested inductors is given in [Table 13](#) with the following test conditions.

Test conditions:

- $V_{in} = 2.8 \text{ V}$
- $V_f = 3.2 \text{ V}$  (per LED)
- $V_f = 0.5 \text{ V}$  (Schottky diode)
- $I_{out} = 25 \text{ mA}$  per string; no dimming

**Table 13. Tested Inductors**

LED CONFIGURATION	INDUCTOR TYPE	INDUCTOR VALUE	SUPPLIER
1 x 6LEDs	LPS3015	18 $\mu\text{H}$	Coilcraft
2 x 6LEDs	LPS4018	47 $\mu\text{H}$	Coilcraft
1 x 10LEDs	LPS4018	47 $\mu\text{H}$	Coilcraft

Other inductors, with lower or higher inductance values can be used. A higher inductance will cause a lower inductor current ripple and therefore will provide higher efficiency. The boost converter will also stay in continuous conduction mode over a wider load current range. The energy stored in an inductor is given by  $E = 1/2L \times I^2$  where  $I$  is the peak inductor current. The maximum current in the inductor is limited by the internal current limit of the device, so the maximum power is given by the minimum peak current limit (see electrical specifications) times the inductance value. For highest output power, a large inductance value is needed. The minimum inductor value possible is limited by the energy needed to supply the load. The limit for the minimum inductor value is given during the on-time of the switch such that the current limit is not reached.

Example for the minimum inductor value:

$$V_{in} = 4.2 \text{ V}, V_{out} = 19.7 \text{ V}, I_{out} = 5 \text{ mA}, V_{sw} = 0.1 \text{ V}$$

$$\rightarrow D = 79\%$$

$$\rightarrow t_{on} = 703 \text{ ns}$$

During the on-time, the inductor current should not reach the current limit of 1.4 A.

With  $V_{L}$  voltage across the inductor ( $V = V_{in} - V_{sw}$ )

$$\rightarrow L = V \times dt/di = (4.2 \text{ V} - 0.1 \text{ V}) \times 703 \text{ ns} / 1.4 \text{ A} = 2 \mu\text{H}$$

#### 11.2.1.2.3.5 Diode Selection

Due to the non-synchronous design of the boost converter, an external diode is needed. For best performance, a Schottky diode with a voltage rating of 40V or above should be used. A diode such as the MBR0540 with an average current rating of 0.5 A is sufficient.

#### 11.2.1.2.3.6 Output Capacitor Selection

A ceramic capacitor such as X5R or X7R type is required at the output. See [Table 14](#) for reference.

**Table 14. Tested Capacitor**

LED CONFIGURATION	TYPICAL VOLTAGE ACROSS OUTPUT CAPACITOR	CAPACITOR VALUE	CAPACITOR SIZE	CAPACITOR TYPE	MANUFACTURER
2x6LEDs or 1x6LEDs	21 V	4.7 $\mu\text{F}$ / 50 V	1206	UMK316BJ475KL	Taiyo Yuden
1x10LEDs	35 V	4.7 $\mu\text{F}$ / 50 V	1210	GRM32ER71H475KA	Murata

### 11.2.1.2.3.7 Input Capacitor Selection

A small ceramic input capacitor of 10 µF is needed at the input of the boost converter. If the inductor is directly connected to the SYS output of TPS6507x, the capacitor can be shared. In this case the capacitance needs to be 22 µF or above. Only X5R or X7R ceramic capacitors should be used.

### 11.2.1.2.4 Battery Charger

#### 11.2.1.2.4.1 Temperature Sensing

The battery charger integrated in TPS6507x has an over temperature protection for the Li-ion cell. The temperature is sensed with a NTC located at the battery. Comparators in TPS6507x suspend charge at a temperature below 0°C and above 45°C. The charger supports two different resistor values for the NTC. The default is internally programmed to 10 kΩ. It is possible to change to a 100-kΩ NTC with the I2C interface.

Table 15. NTCs Supported

RESISTANCE AT 25°C	CURVE / B VALUE	RT2 NEEDED FOR LINEARIZATION	MANUFACTURER
10 kΩ	Curve 2 / B=3477	75 kΩ	Several
100 kΩ	Curve 1 / B=3964	370 kΩ	Several

For best performance, the NTC needs to be linearized by connecting a resistor (RT2) in parallel to the NTC as shown in Figure 47. The resistor value of RT2 needed for linearization can be found in Table 15.

If the battery charger needs to be operated without a NTC connected, for example, for test purposes, a resistor of 10 kΩ or 100 kΩ needs to be connected from TS to GND, depending for which NTC TPS6507x is configured in register CHCONFIG1.

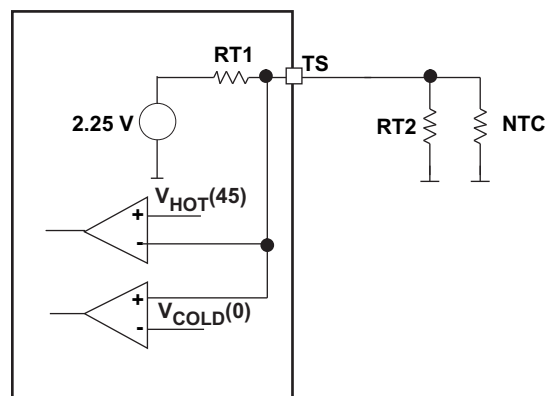

Copyright © 2016, Texas Instruments Incorporated

Figure 46. Linearizing the NTC

#### 11.2.1.2.4.2 Changing the Charging Temperature Range (Default 0°C to 45°C)

The battery charger is designed to operate with the two NTCs listed above. These will give a cold and hot temperature threshold of 0°C and 45°C. If the charger needs to operate (charge) in a wider temperature range, for example, –5°C to 50°C, the circuit can be modified accordingly. The NTC changes its resistance based on the equation listed below:

$$R_{NTC}(T) = R_{25} \times e^{\left( B \times \left( \frac{1}{T} - \frac{1}{T_0} \right) \right)} \quad (18)$$

With:

- R25 = NTC resistance at 25°C
- T = temperature in Kelvin
- T0 = reference temperature (298K)

Resistor RT2 in parallel to the NTC is used to linearize the resistance change with temperature of the NTC. As the NTC has a high resistance at low temperature, the resulting resistance of NTC in parallel with RT2 is lower especially for low temperatures where the NTC has a high resistance, so RT2 in parallel has a significant impact. For higher temperatures, the resistance of the NTC dropped significantly, so RT2 in parallel does not change the resulting resistance a lot. See Figure 47.

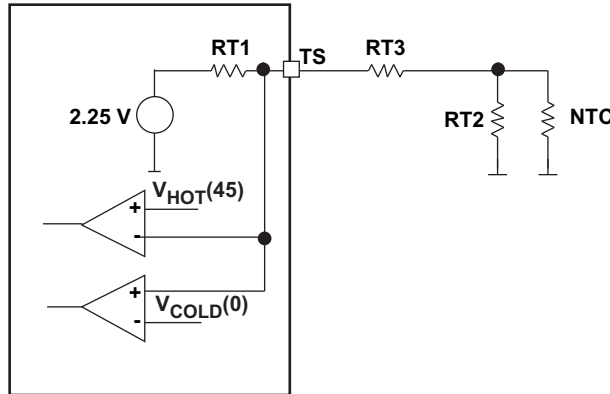

Copyright © 2016, Texas Instruments Incorporated

Figure 47. Changing the Temperature Range

### 11.2.1.3 Application Curves

As Figure 48 shows, the result is an extended charging temperature range at lower temperatures. The upper temperature limit is shifted to lower values as well resulting in a V(HOT) temperature of slightly less than 45°C. Therefore RT3 is needed to shift the temperature range to higher temperatures again. Figure 49 shows the result for:

- RT2 = 47 kΩ
- RT3 = 820 R

Using these values will extend the temperature range for charging to –5°C to 50°C.

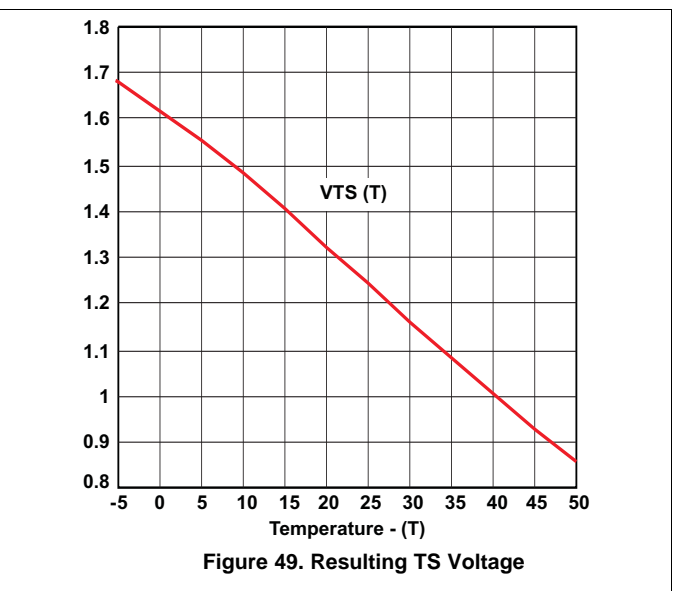
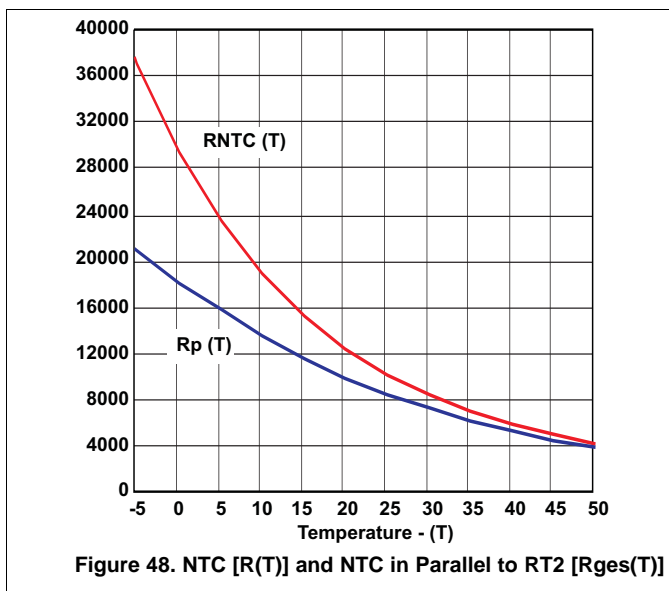

## 11.2.2 Powering OMAP-L138

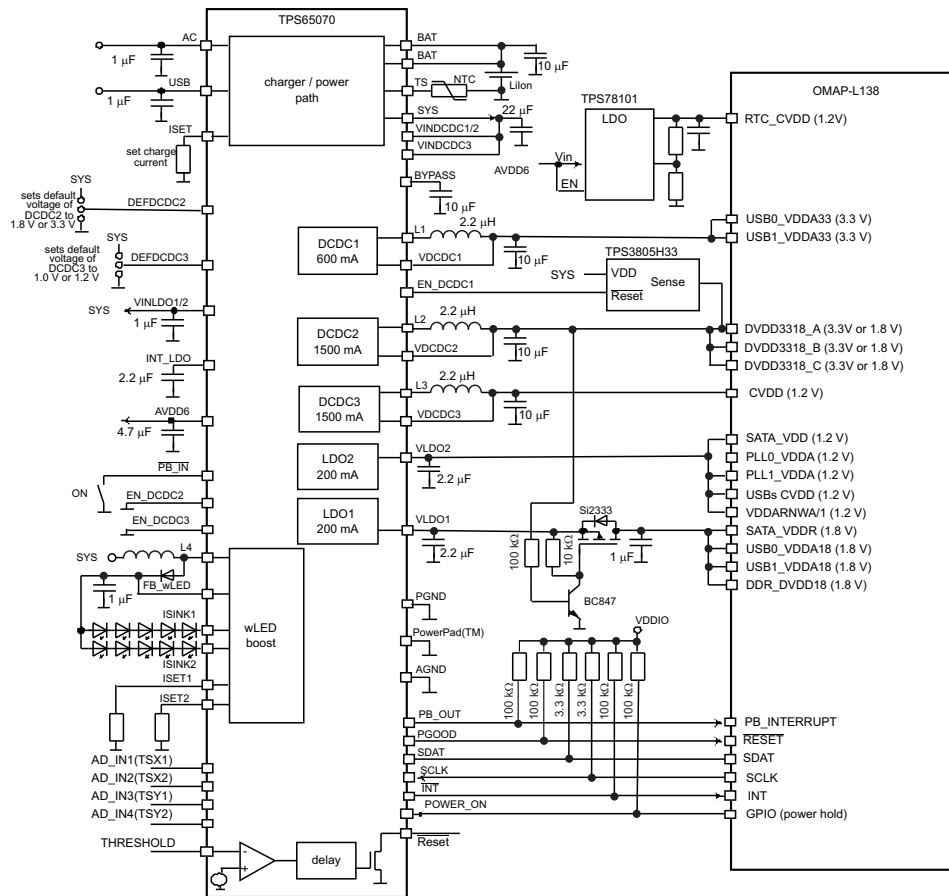

Copyright © 2016, Texas Instruments Incorporated

Figure 50. Powering OMAP-L138

### 11.2.2.1 Design Requirements

Table 16. OMAP - L138 Power Table

DEVICE REGULATOR	VOLTAGE	PROCESSOR RAIL NAME	SEQUENCE
DCDC1	3.3 V	USB0_VDDA33 USB1_VDDA33	5
DCDC2	3.3 V or 1.8 V	DVDD3318_A DVDD3318_B DVDD3318_C	3
DCDC3	1.2 V	CVDD	1
LDO1	1.2 V	SATA_VDD PLL0_VDDA PLL1_VDDA USBs_CVDD VDDARNWA/1	4
LDO2	1.8 V	SATA_VDDR USB0_VDDA18 USB1_VDDA18 DDR_DVDD18	2

### 11.2.2.2 Detailed Design Procedure

Using the requirements above follow the procedure from *Detailed Design Procedure* to design the TPS6507x for the OMAP-L138.

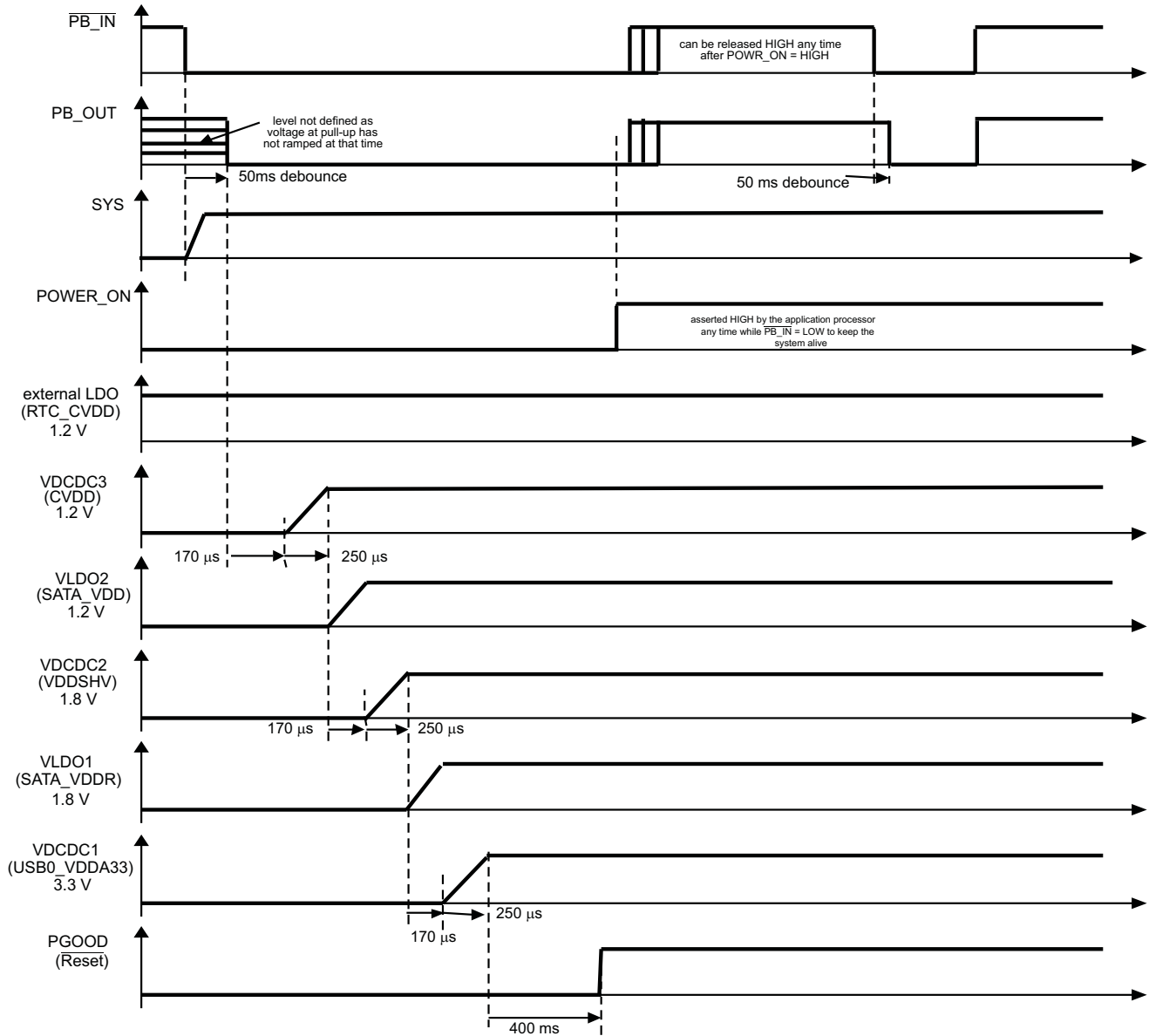

Figure 51. Sequence for OMAP-L138

### 11.2.3 Powering Atlas IV

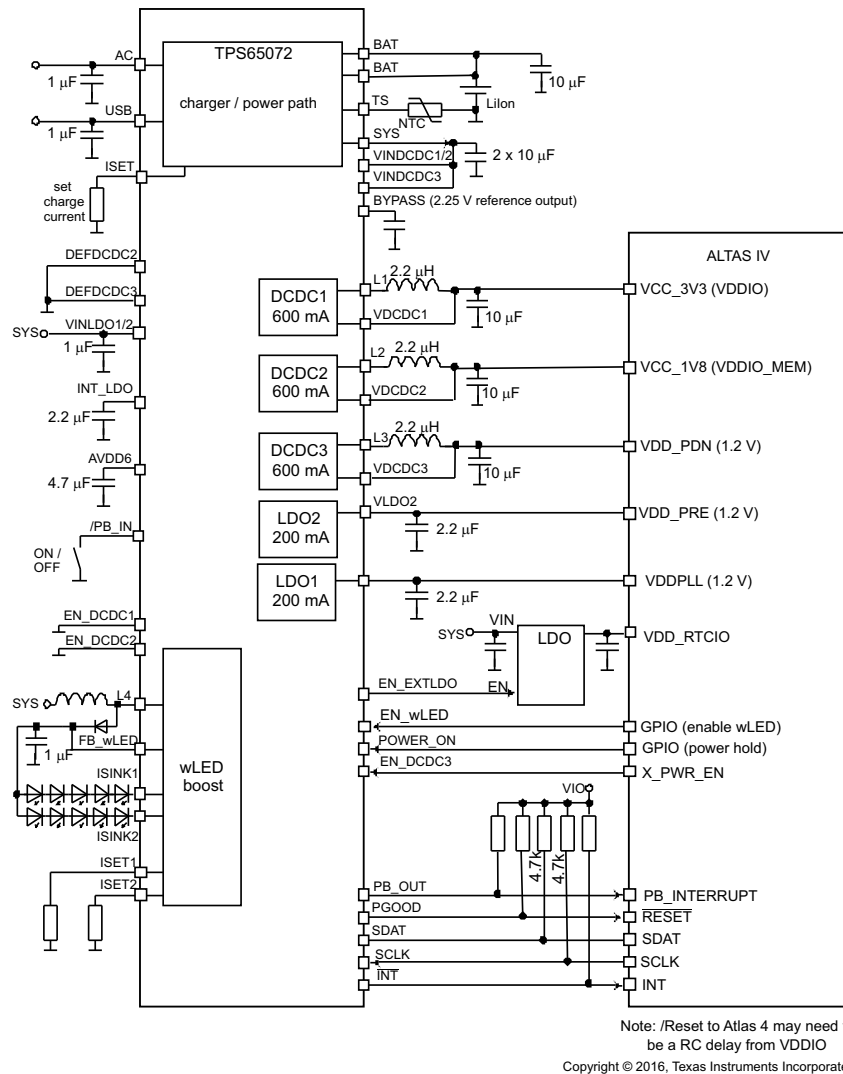

Figure 52. Powering Atlas IV

#### 11.2.3.1 Design Requirements

Table 17. Atlas IV Power Table

DEVICE REGULATOR	VOLTAGE	PROCESSOR RAIL NAME	SEQUENCE
DCDC1	3.3 V	VCC_3V3 (VDDIO)	2
DCDC2	1.8 V	VCC_1V8 (VDDIO_MEM)	2
DCDC3	1.2 V	VDD_PDN	3
LDO1	1.2 V	VDD_PRE	3
LDO2	1.2 V	VDDPLL	1

### 11.2.3.2 Detailed Design Procedure

Using the requirements above follow the procedure from [Detailed Design Procedure](#) to design the TPS6507x for the Atlas IV.

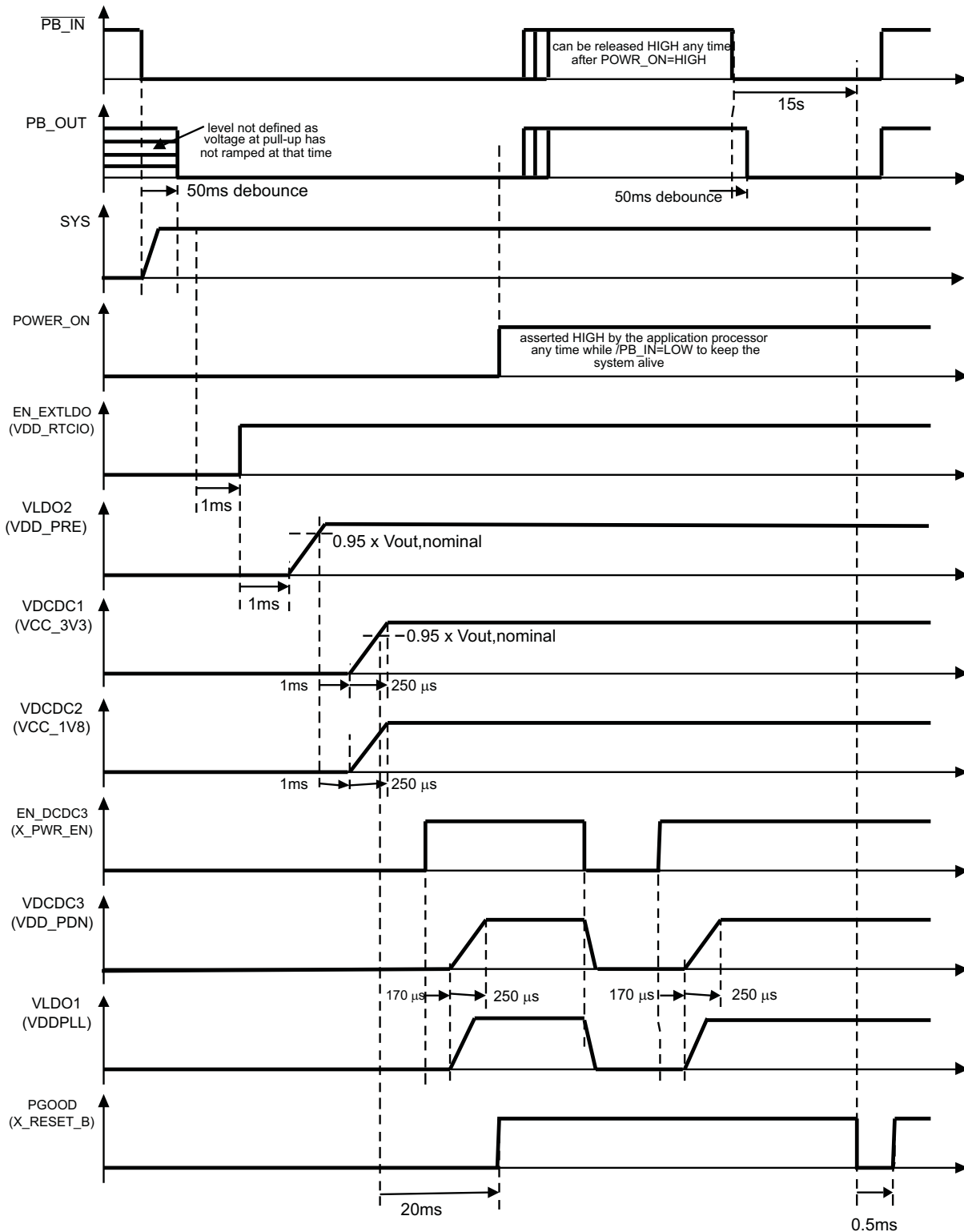

Figure 53. Sequence for Atlas IV

### 11.2.3.2.1 Prima SLEEP Mode and DEEP SLEEP Mode Support

TPS6507x contains a sequencing option for the Sifir Prima processor. The sequencing option defines how the voltages are ramped at initial power-up and shutdown as well as the timing for entering power save mode for the processor (SLEEP mode). The Prima processor supports SLEEP mode and also DEEP SLEEP mode. The main difference from a power supply point of view is:

- How the supply voltages are turned off
- Which voltages are turned off
- How power save mode is exited into normal mode
- Reset asserted or not (PGOOD pin of TPS6507x going actively low)

The sequencing option for Prima is defined in one register each for the sequencing of the DC-DC converters and for the LDOs. DCDC\_SQ[2..0]=100 in register CON\_CTRL1 defines the start-up sequence for the DC-DC converters while LDO\_SQ[2..0]=111 defines the sequence for the LDOs. The default is factory programmed therefore it is ensured the first power-up is done in the right sequence.

When TPS6507x is off, a small state machine supervises the status of pin PB\_IN while major blocks are not powered for minimum current consumption from the battery as long as there is no input voltage to the charger. Power-up for the TPS6507x is started by PB\_IN going LOW. This will turn on the power-FET from the battery so the system voltage (SYS) is rising and the main blocks of the PMU are powered. After a debounce time of 50 ms, the main state machine will pull PB\_OUT = LOW to indicate that there is a “keypress” by the user and will ramp the DC-DC converters and LDOs according to the sequence programmed. It is important to connect the power rails for the processor to exactly the DC-DC converters and LDOs as shown in the schematic and sequencing diagrams for proper sequencing. For Prima, the voltage rails for VDD\_RTCIO needs to ramp first. This power rail is not provided by the PMU but from an external LDO which is enabled by a signal called EN\_EXTLDO from the PMU. The PMU will therefore first rise the logic level on pin EN\_EXTLDO high to enable the external LDO. After a 1-ms delay the PMU will ramp LDO2 for VDD\_PRE and DCDC3 for VDD\_PDN. When the output voltage of LDO2 is within its nominal range the internal power good comparator will trigger the state machine which will ramp DCDC1 and DCDC2 to provide the supply voltage for VCC\_3V3 and VCC\_1V8. Now Prima needs to pull its X\_PWR\_EN signal high which drives EN\_DCDC3 on the PMU. This will now enable LDO1 to power VDDPLL. X\_RESET\_B will be released by the PMU on pin PGOOD based on the voltage of DCDC1 after a delay of 20 ms.

### 11.2.3.2.2 SLEEP Mode

At first power-up (start-up from OFF state), the voltage for VDD\_PDN is ramped at the same time than VDD\_PRE. This is defined by Bit MASK\_EN\_DCDC3 in register CON\_CTRL2 which is “1” per default. For enabling SLEEP mode, Prima needs to clear this Bit, so the EN\_DCDC3 pin takes control over the DCDC3 converter. Prima SLEEP mode is initialized by Prima pulling its X\_PWR\_EN pin LOW which is driving the EN\_DCDC3 pin of TPS6507x. This will turn off the power for VDDPLL (LDO1) and also for VDD\_PDN (DCDC3). All other voltage rails will stay on. Based on a “keypress” with PB\_OUT going LOW, Prima will wake up and assert EN\_DCDC3=HIGH. This will turn DCDC3 and LDO1 back on and Sifir PRIMA will enter normal operating mode.

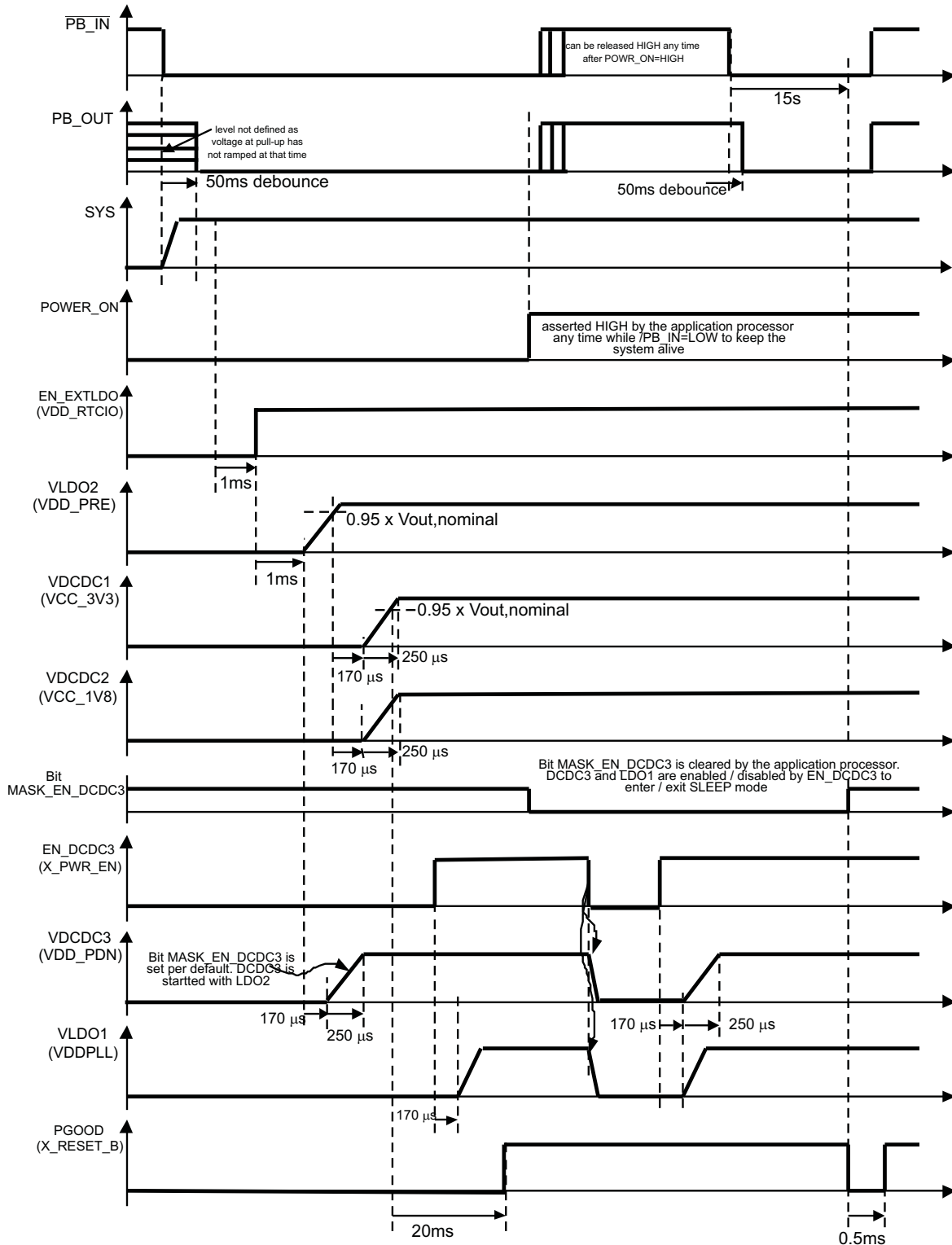

Figure 54. Sequence for Sirf Prima SLEEP Mode

### 11.2.3.2.3 DEEP SLEEP Mode

Entry into DEEP SLEEP mode is controlled by Prima by writing to register CON\_CTRL2 of TPS6507x. Before entering DEEP SLEEP mode, Prima will back up all memory and set Bit DS\_RDY=1 to indicate the memory was saved and the content is valid. Setting PWR\_DS=1 will turn off all voltage rails except DCDC2 for the memory voltage and the PMU will apply a reset signal by pulling PGOOD=LOW. Prima can not detect logic level change by PB\_OUT going low in DEEP SLEEP mode. A wakeup from DEEP sleep is therefore managed by the PMU. The PMU will clear Bit PWR\_DS and turn on the converters again based on a user “keypress” when PB\_IN is being pulled LOW. Prima will now check if DS\_RDY=1 to determine if the memory content is still valid and clear the Bit afterwards. In case there is a power loss and the voltage of the PMU is dropping below the undervoltage lockout threshold, the registers in the PMU are re-set to the default and DS\_RDY is cleared. The PMU would perform a start-up from OFF state instead of exit from DEEP SLEEP and Sirf PRIMA would read DS\_RDY=0, which indicates memory data is not valid.

See Sequence diagrams for Sirf Prima SLEEP and DEEP SLEEP in [Figure 54](#) and [Figure 55](#).

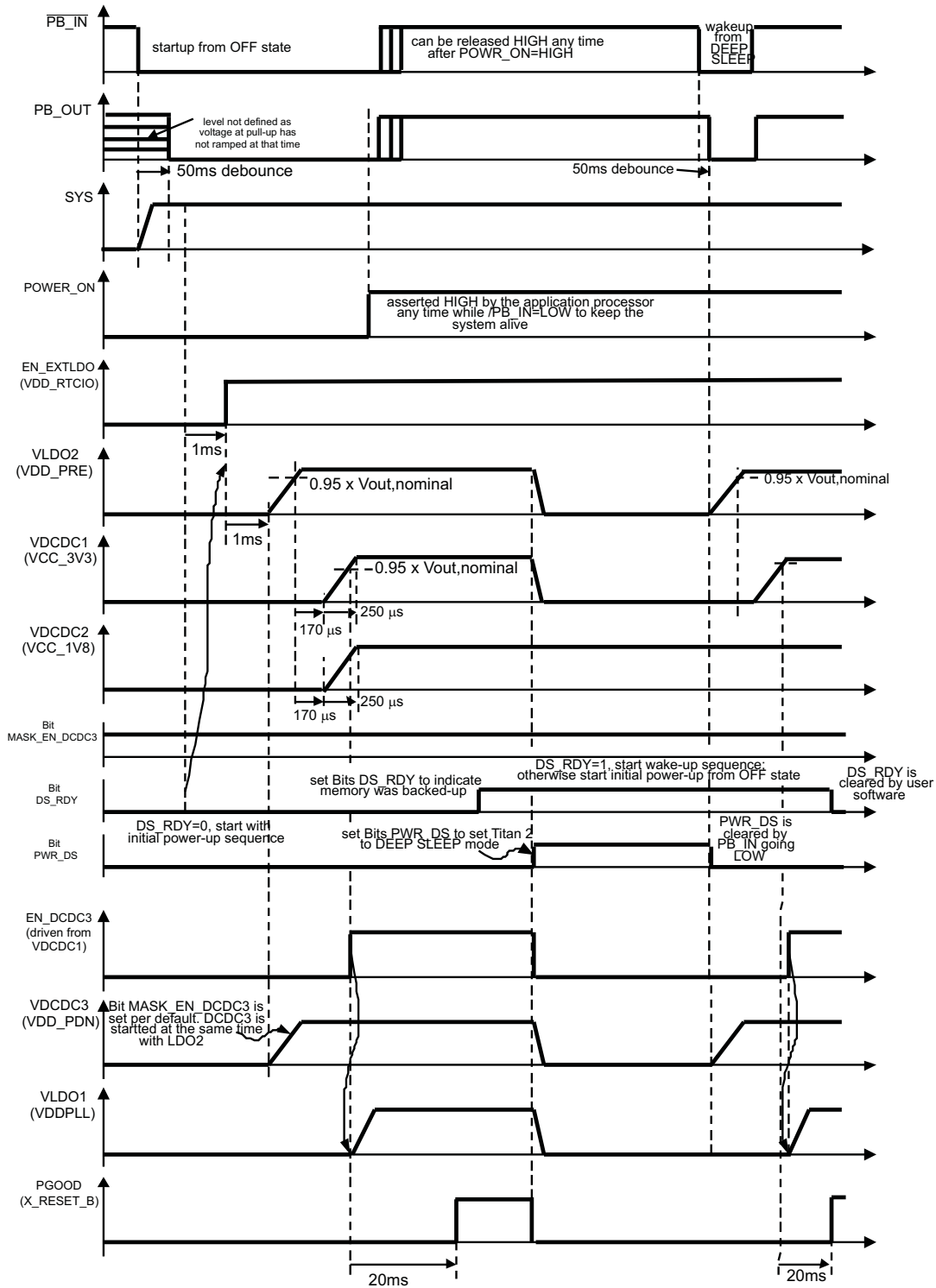
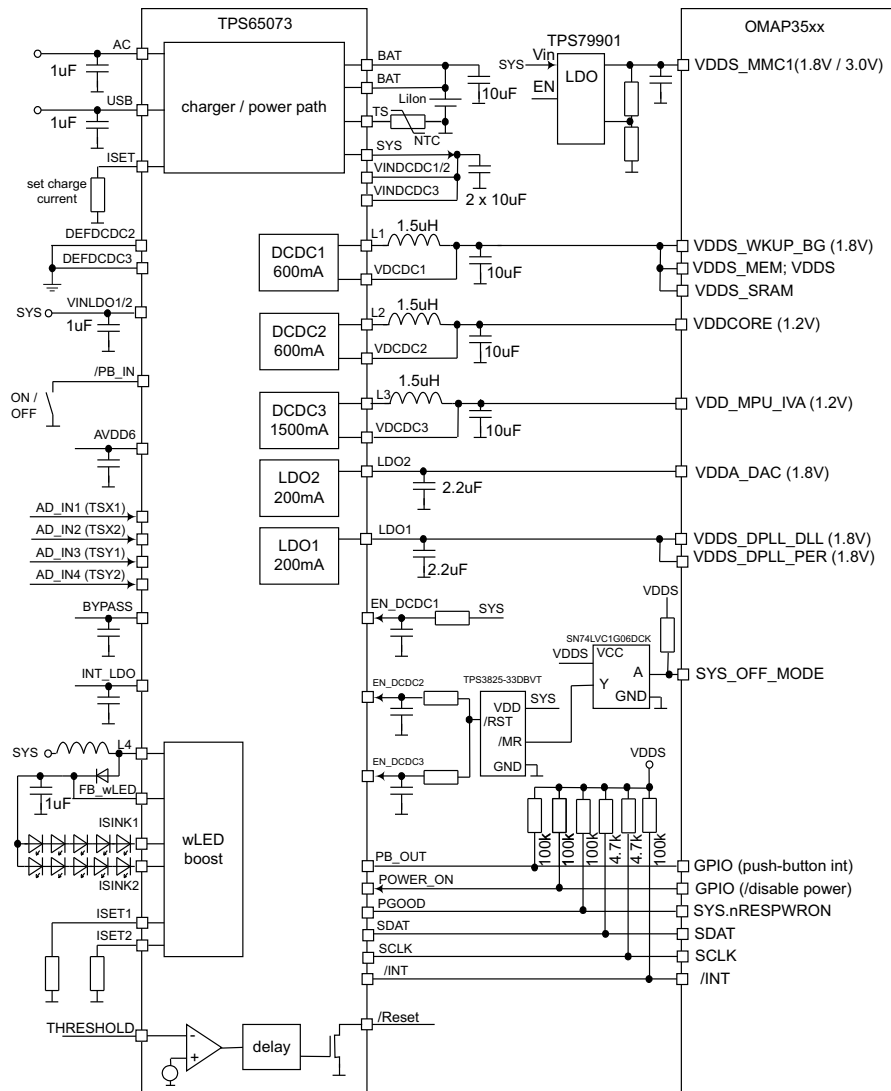

Figure 55. Sequence for Sirf Prima DEEP SLEEP Mode

### 11.2.4 OMAP35xx (Supporting SYS-OFF Mode)



Copyright © 2016, Texas Instruments Incorporated

Figure 56. OMAP35xx (Supporting SYS-OFF Mode)

#### 11.2.4.1 Design Requirements

Table 18. OMAP - 35xx Power Table

DEVICE REGULATOR	VOLTAGE	PROCESSOR RAIL NAME	SEQUENCE
DCDC1	1.8 V	VDD5_WKUP_BG VDD5_MEM; VDD5 VDD5_SRAM	1
DCDC2	1.2 V	VDDCORE	2
DCDC3	1.2 V	VDD_MPU_IVA	3
LDO1	1.8 V	VDDA_DAC	4
LDO2	1.8 V	VDD5_DPLL_DLL VDD5_DPLL_PER	4

### 11.2.4.2 Detailed Design Procedure

Using the requirements above follow the procedure from *Detailed Design Procedure* to design the TPS6507x for the OMAP-35xx.

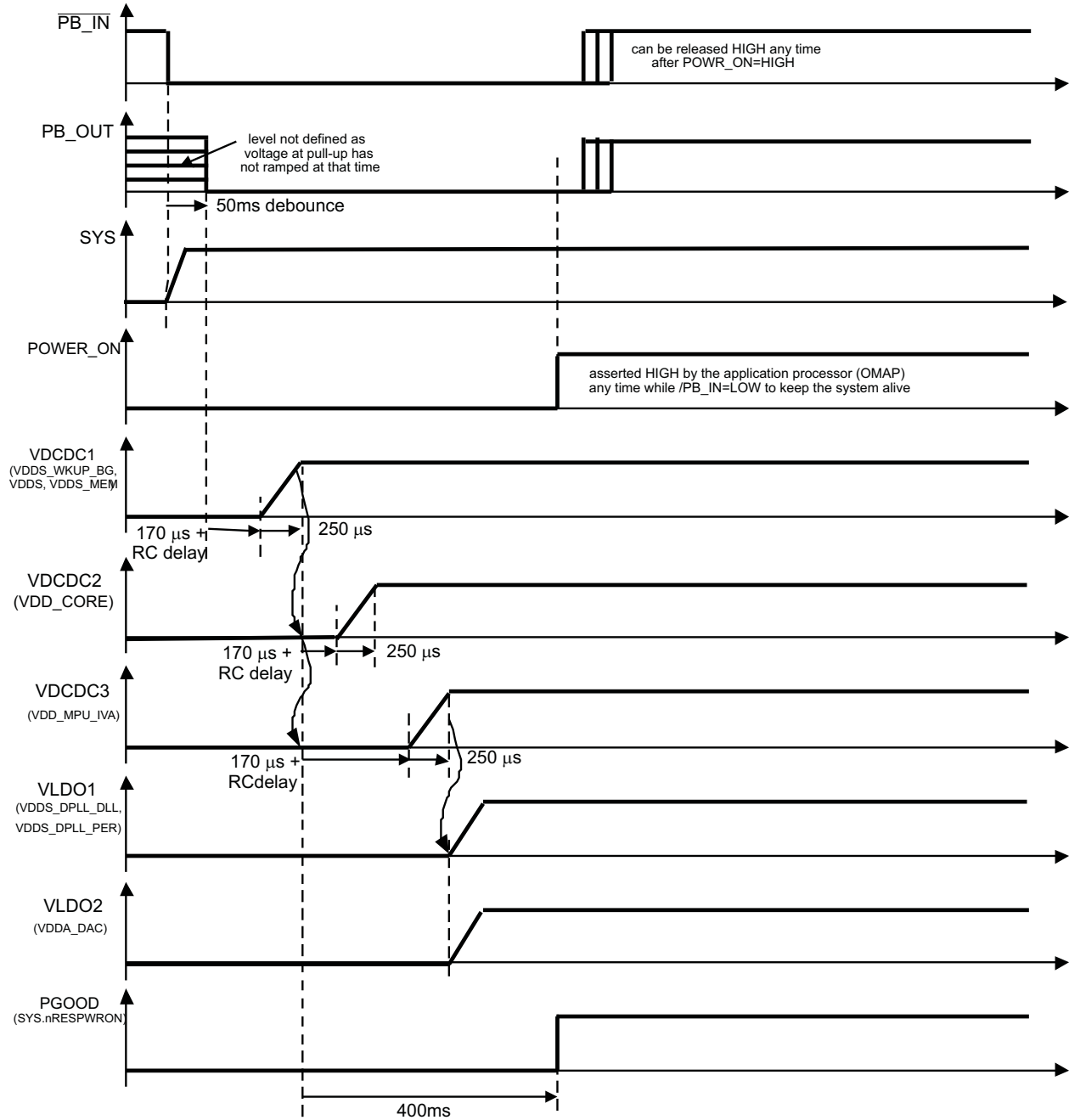
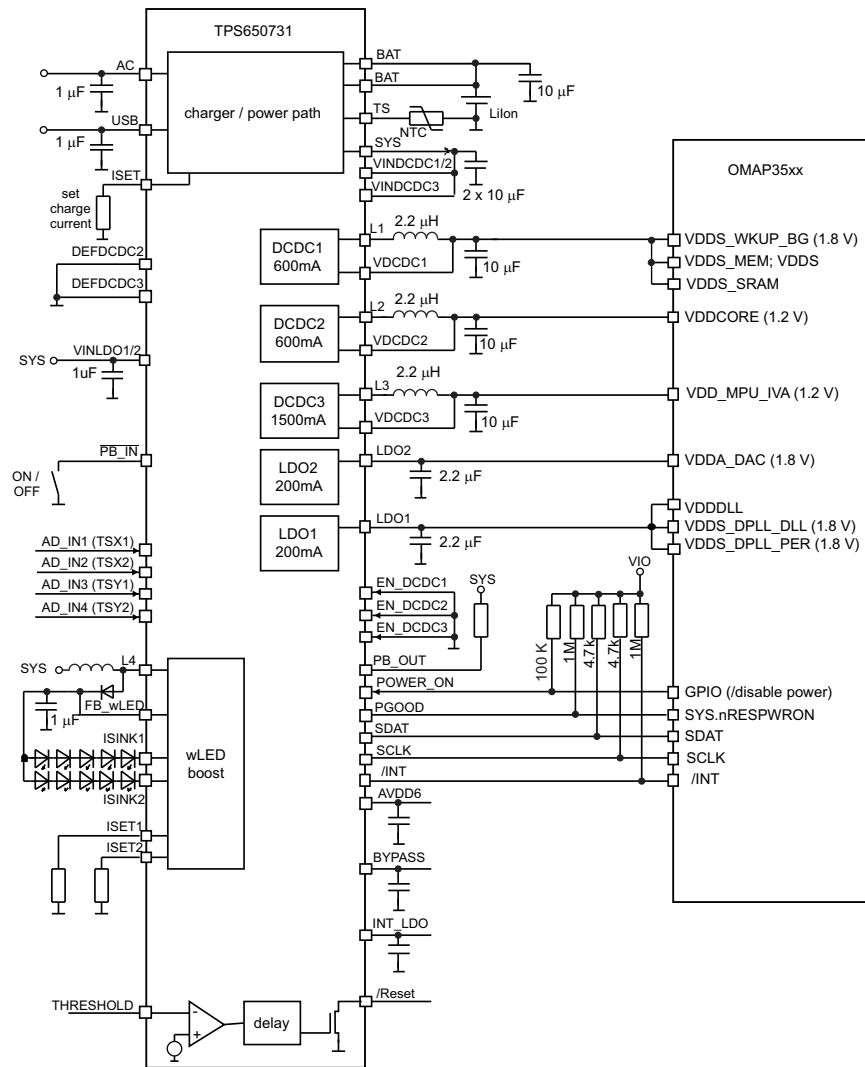

Figure 57. OMAP35xx Sequence (Supporting SYS-OFF Mode)

### 11.2.5 TPS650731 for OMAP35xx



Copyright © 2016, Texas Instruments Incorporated

Figure 58. TPS650731 for OMAP35xx

#### 11.2.5.1 Design Requirements

Table 19. OMAP - 35xx Power Table

DEVICE REGULATOR	VOLTAGE	PROCESSOR RAIL NAME	SEQUENCE
DCDC1	1.8 V	VDDS_WKUP_BG VDDS_MEM; VDDS VDDS_SRAM	1
DCDC2	1.2 V	VDDCORE	2
DCDC3	1.2 V	VDD_MPU_IVA	4
LDO1	1.8 V	VDDA_DAC	3
LDO2	1.8 V	VDDLL VDDS_DPLL_DLL VDDS_DPLL_PER	

### 11.2.5.2 Detailed Design Procedure

Using the requirements above follow the procedure from *Detailed Design Procedure* to design the TPS6507x for the OMAP-35xx.

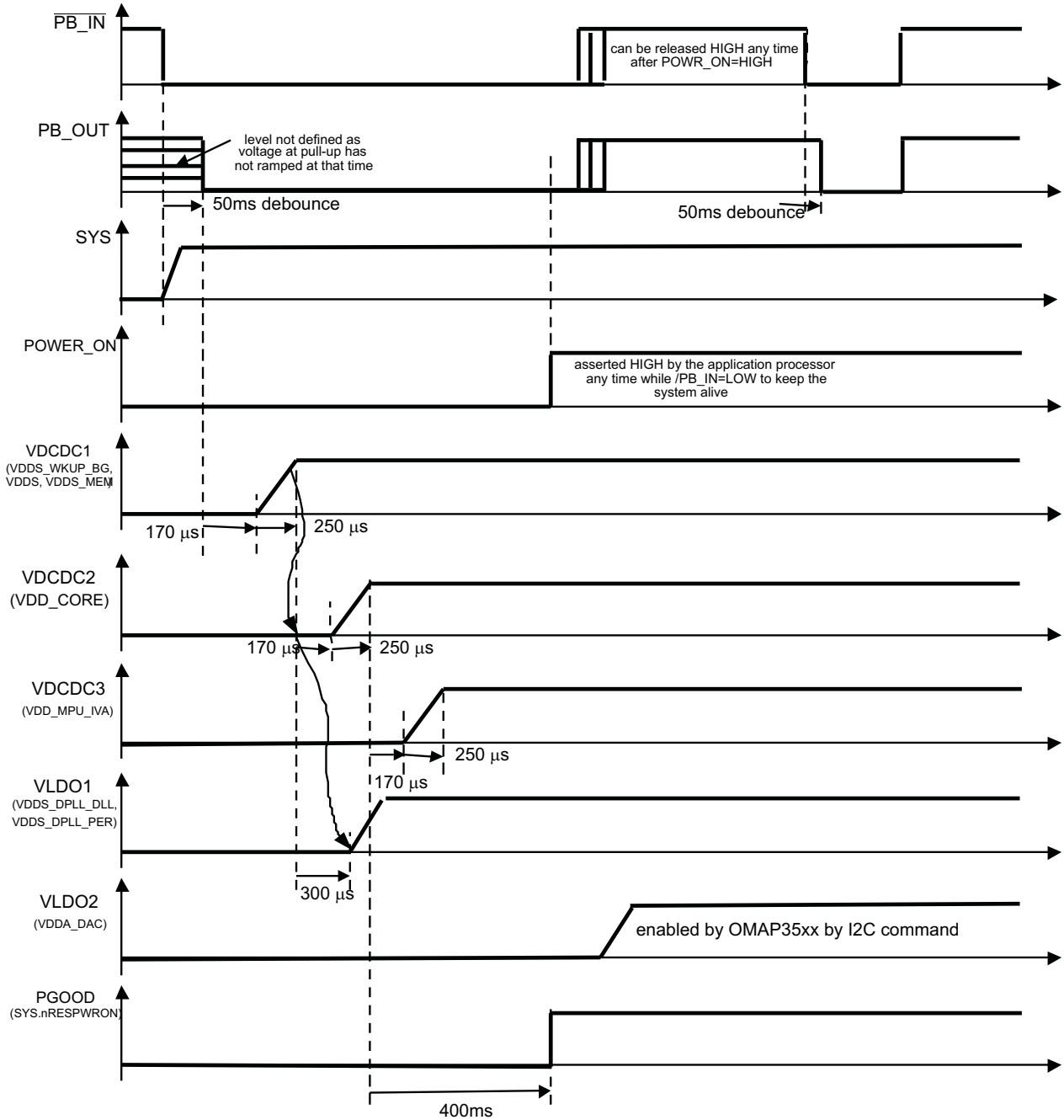
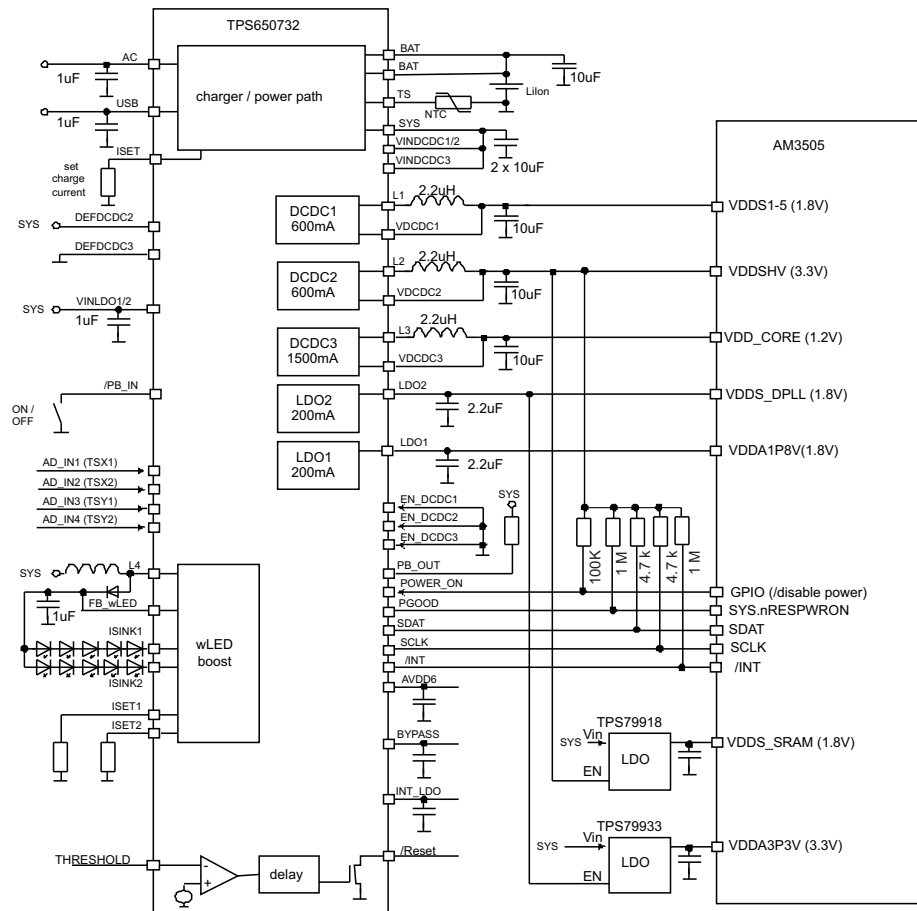

Figure 59. TPS650731: OMAP35xx Sequence

### 11.2.6 Powering AM3505 Using TPS650732



Copyright © 2016, Texas Instruments Incorporated

Figure 60. Powering AM3505 Using TPS650732

#### 11.2.6.1 Design Requirements

Table 20. AM3505 Power Table

DEVICE REGULATOR	VOLTAGE	PROCESSOR RAIL NAME	SEQUENCE
DCDC1	1.8V	VDDS1-5	1
DCDC2	3.3V	VDDSHV	2
DCDC3	1.2V	VDD_CORE	4
LDO1	1.8V	VDDS_DPLL	5
LDO2	1.8V	VDDA1P8V	5
external LDO1	1.8V	VDDS_SRAM	3
external LDO2	3.3V	VDDA3P3V	6

### 11.2.6.2 Detailed Design Procedure

Using the requirements above follow the procedure from [Detailed Design Procedure](#) to design the TPS6507x for the AM505.

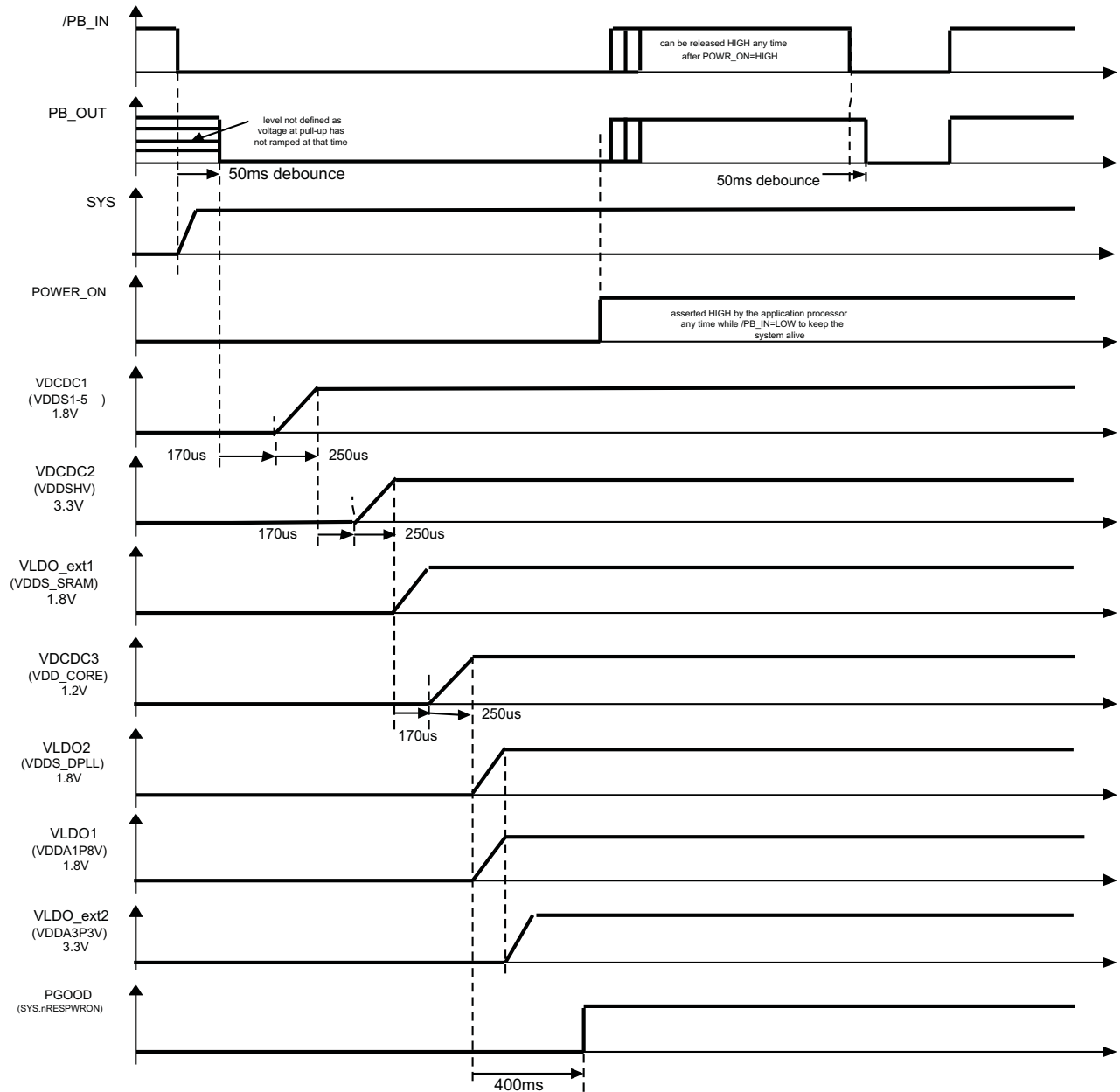

Figure 61. Sequence Using TPS650732 for AM3505

## 12 Power Supply Recommendations

Power to the TPS6507x can receive power from one of the following three different inputs: AC, USB, or battery. A signal cell Li-Ion battery is recommended for use. A supply from 4.3 V to 5.8 V is recommended for the AC and USB inputs.

## 13 Layout

### 13.1 Layout Guidelines

As for all switching power supplies, the layout is an important step in the design. Proper function of the device demands careful attention to PCB layout. Care must be taken in board layout to get the specified performance. If the layout is not carefully done, the regulators may show poor line and/or load regulation, and stability issues as well as EMI problems. It is critical to provide a low impedance ground path. Therefore, use wide and short traces for the main current paths. The input capacitors should be placed as close as possible to the IC pins as well as the inductor and output capacitor.

For TPS6507x, connect the PGND pin of the device to the thermal pad land of the PCB and connect the analog ground connection (GND) to the PGND at the thermal pad. The thermal pad serves as the power ground connection for the DCDC1 and DCDC2 converters. Therefore it is essential to provide a good thermal and electrical connection to GND using multiple vias to the GND-plane. Keep the common path to the GND pin, which returns the small signal components, and the high current of the output capacitors as short as possible to avoid ground noise. The VDCDCx line should be connected right to the output capacitor and routed away from noisy components and traces (for example, the L1, L2, L3 and L4 traces). See the [TPS6507xEVM users guide](#) for details about the layout for TPS6507x.

### 13.2 Layout Example

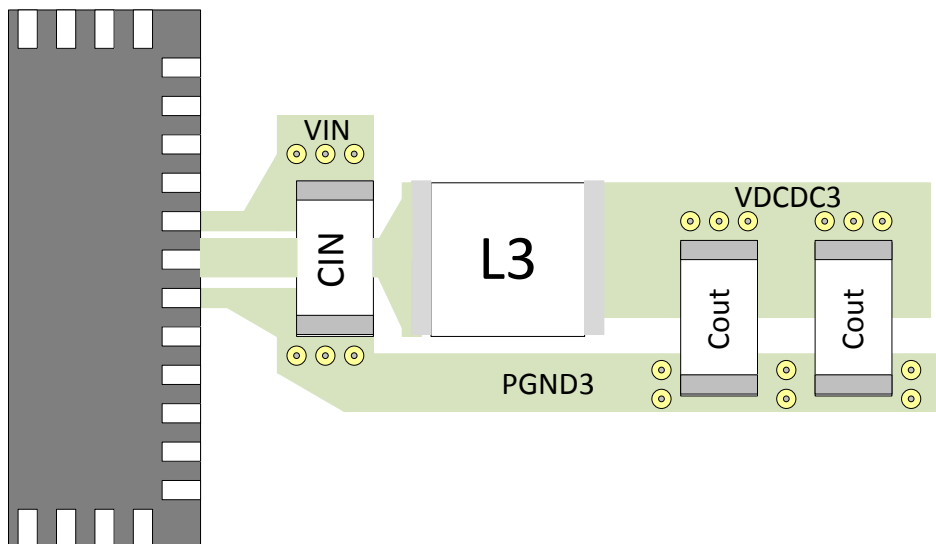

Figure 62. Converter Layout Example

## 14 Device and Documentation Support

### 14.1 Device Support

#### 14.1.1 Third-Party Products Disclaimer

TI'S PUBLICATION OF INFORMATION REGARDING THIRD-PARTY PRODUCTS OR SERVICES DOES NOT CONSTITUTE AN ENDORSEMENT REGARDING THE SUITABILITY OF SUCH PRODUCTS OR SERVICES OR A WARRANTY, REPRESENTATION OR ENDORSEMENT OF SUCH PRODUCTS OR SERVICES, EITHER ALONE OR IN COMBINATION WITH ANY TI PRODUCT OR SERVICE.

### 14.2 Documentation Support

#### 14.2.1 Related Documentation

For related documentation, see the following:

- Texas Instruments, [Basic Calculation of a Boost Converter's Power Stage application report](#)
- Texas Instruments, [Basic Calculation of a Buck Converter's Power Stage application report](#)
- Texas Instruments, [Choosing an Appropriate Pull-up/Pull-down Resistor for Open Drain Outputs application report](#)
- Texas Instruments, [Dynamic Power-Path Management and Dynamic Power Management application report](#)
- Texas Instruments, [How to Power the TPS6507x On and Off application report](#)
- Texas Instruments, [Powering OMAP-L132/L138, C6742/4/6, and AM18x with TPS65070 application report](#)
- Texas Instruments, [TPS6507xEVM user's guide](#)
- Texas Instruments, [Understanding the Absolute Maximum Ratings of the SW Node application report](#)

#### 14.3 Related Links

The table below lists quick access links. Categories include technical documents, support and community resources, tools and software, and quick access to sample or buy.

**Table 21. Related Links**

PARTS	PRODUCT FOLDER	ORDER NOW	TECHNICAL DOCUMENTS	TOOLS & SOFTWARE	SUPPORT & COMMUNITY
TPS65070	<a href="#">Click here</a>	<a href="#">Click here</a>	<a href="#">Click here</a>	<a href="#">Click here</a>	<a href="#">Click here</a>
TPS65072	<a href="#">Click here</a>	<a href="#">Click here</a>	<a href="#">Click here</a>	<a href="#">Click here</a>	<a href="#">Click here</a>
TPS65073	<a href="#">Click here</a>	<a href="#">Click here</a>	<a href="#">Click here</a>	<a href="#">Click here</a>	<a href="#">Click here</a>
TPS650731	<a href="#">Click here</a>	<a href="#">Click here</a>	<a href="#">Click here</a>	<a href="#">Click here</a>	<a href="#">Click here</a>
TPS650732	<a href="#">Click here</a>	<a href="#">Click here</a>	<a href="#">Click here</a>	<a href="#">Click here</a>	<a href="#">Click here</a>

#### 14.4 Receiving Notification of Documentation Updates

To receive notification of documentation updates, navigate to the device product folder on ti.com. In the upper right corner, click on *Alert me* to register and receive a weekly digest of any product information that has changed. For change details, review the revision history included in any revised document.

#### 14.5 Community Resources

The following links connect to TI community resources. Linked contents are provided "AS IS" by the respective contributors. They do not constitute TI specifications and do not necessarily reflect TI's views; see TI's [Terms of Use](#).

**TI E2E™ Online Community** *TI's Engineer-to-Engineer (E2E) Community*. Created to foster collaboration among engineers. At e2e.ti.com, you can ask questions, share knowledge, explore ideas and help solve problems with fellow engineers.

**Design Support** *TI's Design Support* Quickly find helpful E2E forums along with design support tools and contact information for technical support.

## 14.6 Trademarks

OMAP, E2E are trademarks of Texas Instruments.  
All other trademarks are the property of their respective owners.

## 14.7 Electrostatic Discharge Caution



This integrated circuit can be damaged by ESD. Texas Instruments recommends that all integrated circuits be handled with appropriate precautions. Failure to observe proper handling and installation procedures can cause damage.

ESD damage can range from subtle performance degradation to complete device failure. Precision integrated circuits may be more susceptible to damage because very small parametric changes could cause the device not to meet its published specifications.

## 14.8 Glossary

[SLYZ022](#) — *TI Glossary*.

This glossary lists and explains terms, acronyms, and definitions.

## 15 Mechanical, Packaging, and Orderable Information

The following pages include mechanical, packaging, and orderable information. This information is the most current data available for the designated devices. This data is subject to change without notice and revision of this document. For browser-based versions of this data sheet, refer to the left-hand navigation.

**PACKAGING INFORMATION**

Orderable Device	Status (1)	Package Type	Package Drawing	Pins	Package Qty	Eco Plan (2)	Lead/Ball Finish (6)	MSL Peak Temp (3)	Op Temp (°C)	Device Marking (4/5)	Samples
TPS65070RSLR	ACTIVE	VQFN	RSL	48	2500	Green (RoHS & no Sb/Br)	CU NIPDAU	Level-3-260C-168 HR	-40 to 85	TPS 65070	<a href="#">Samples</a>
TPS65070RSLT	ACTIVE	VQFN	RSL	48	250	Green (RoHS & no Sb/Br)	CU NIPDAU	Level-3-260C-168 HR	-40 to 85	TPS 65070	<a href="#">Samples</a>
TPS65072RSLR	ACTIVE	VQFN	RSL	48	2500	Green (RoHS & no Sb/Br)	CU NIPDAU	Level-3-260C-168 HR	-40 to 85	TPS 65072	<a href="#">Samples</a>
TPS65072RSLT	ACTIVE	VQFN	RSL	48	250	Green (RoHS & no Sb/Br)	CU NIPDAU	Level-3-260C-168 HR	-40 to 85	TPS 65072	<a href="#">Samples</a>
TPS650731RSLR	ACTIVE	VQFN	RSL	48	2500	Green (RoHS & no Sb/Br)	CU NIPDAU	Level-3-260C-168 HR	-40 to 85	TPS 650731	<a href="#">Samples</a>
TPS650731RSLT	ACTIVE	VQFN	RSL	48	250	Green (RoHS & no Sb/Br)	CU NIPDAU	Level-3-260C-168 HR	-40 to 85	TPS 650731	<a href="#">Samples</a>
TPS650732RSLR	ACTIVE	VQFN	RSL	48	2500	Green (RoHS & no Sb/Br)	CU NIPDAU	Level-3-260C-168 HR	-40 to 85	TPS 650732	<a href="#">Samples</a>
TPS650732RSLT	ACTIVE	VQFN	RSL	48	250	Green (RoHS & no Sb/Br)	CU NIPDAU	Level-3-260C-168 HR	-40 to 85	TPS 650732	<a href="#">Samples</a>
TPS65073RSLR	ACTIVE	VQFN	RSL	48	2500	Green (RoHS & no Sb/Br)	CU NIPDAU	Level-3-260C-168 HR	-40 to 85	TPS 65073	<a href="#">Samples</a>
TPS65073RSLT	ACTIVE	VQFN	RSL	48	250	Green (RoHS & no Sb/Br)	CU NIPDAU	Level-3-260C-168 HR	-40 to 85	TPS 65073	<a href="#">Samples</a>

(1) The marketing status values are defined as follows:

**ACTIVE:** Product device recommended for new designs.

**LIFEBUY:** TI has announced that the device will be discontinued, and a lifetime-buy period is in effect.

**NRND:** Not recommended for new designs. Device is in production to support existing customers, but TI does not recommend using this part in a new design.

**PREVIEW:** Device has been announced but is not in production. Samples may or may not be available.

**OBSOLETE:** TI has discontinued the production of the device.

(2) Eco Plan - The planned eco-friendly classification: Pb-Free (RoHS), Pb-Free (RoHS Exempt), or Green (RoHS & no Sb/Br) - please check <http://www.ti.com/productcontent> for the latest availability information and additional product content details.

**TBD:** The Pb-Free/Green conversion plan has not been defined.

**Pb-Free (RoHS):** TI's terms "Lead-Free" or "Pb-Free" mean semiconductor products that are compatible with the current RoHS requirements for all 6 substances, including the requirement that lead not exceed 0.1% by weight in homogeneous materials. Where designed to be soldered at high temperatures, TI Pb-Free products are suitable for use in specified lead-free processes.

**Pb-Free (RoHS Exempt):** This component has a RoHS exemption for either 1) lead-based flip-chip solder bumps used between the die and package, or 2) lead-based die adhesive used between the die and leadframe. The component is otherwise considered Pb-Free (RoHS compatible) as defined above.

**Green (RoHS & no Sb/Br):** TI defines "Green" to mean Pb-Free (RoHS compatible), and free of Bromine (Br) and Antimony (Sb) based flame retardants (Br or Sb do not exceed 0.1% by weight in homogeneous material)

- (3) MSL, Peak Temp. - The Moisture Sensitivity Level rating according to the JEDEC industry standard classifications, and peak solder temperature.
- (4) There may be additional marking, which relates to the logo, the lot trace code information, or the environmental category on the device.
- (5) Multiple Device Markings will be inside parentheses. Only one Device Marking contained in parentheses and separated by a "~" will appear on a device. If a line is indented then it is a continuation of the previous line and the two combined represent the entire Device Marking for that device.
- (6) Lead/Ball Finish - Orderable Devices may have multiple material finish options. Finish options are separated by a vertical ruled line. Lead/Ball Finish values may wrap to two lines if the finish value exceeds the maximum column width.

**Important Information and Disclaimer:**The information provided on this page represents TI's knowledge and belief as of the date that it is provided. TI bases its knowledge and belief on information provided by third parties, and makes no representation or warranty as to the accuracy of such information. Efforts are underway to better integrate information from third parties. TI has taken and continues to take reasonable steps to provide representative and accurate information but may not have conducted destructive testing or chemical analysis on incoming materials and chemicals. TI and TI suppliers consider certain information to be proprietary, and thus CAS numbers and other limited information may not be available for release.

In no event shall TI's liability arising out of such information exceed the total purchase price of the TI part(s) at issue in this document sold by TI to Customer on an annual basis.

**OTHER QUALIFIED VERSIONS OF TPS650732 :**

- Automotive: [TPS650732-Q1](#)

**NOTE:** Qualified Version Definitions:

- Automotive - Q100 devices qualified for high-reliability automotive applications targeting zero defects

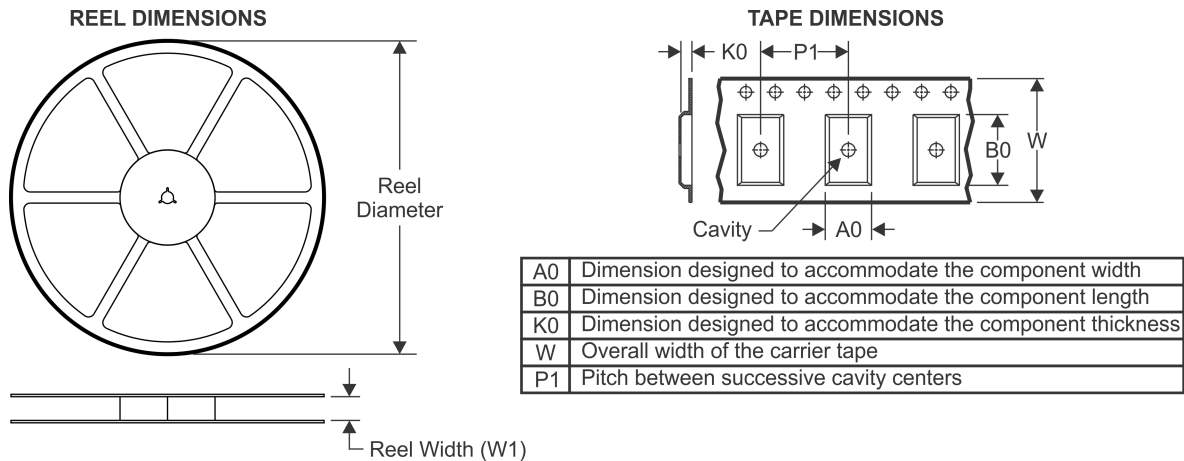
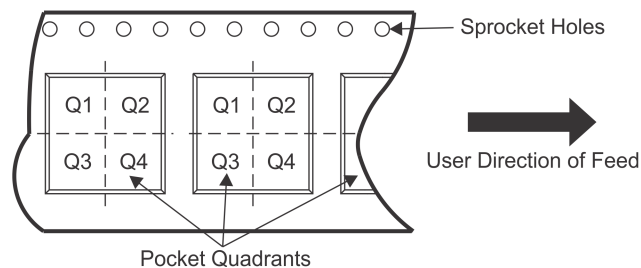
**TAPE AND REEL INFORMATION**

**QUADRANT ASSIGNMENTS FOR PIN 1 ORIENTATION IN TAPE**

\*All dimensions are nominal

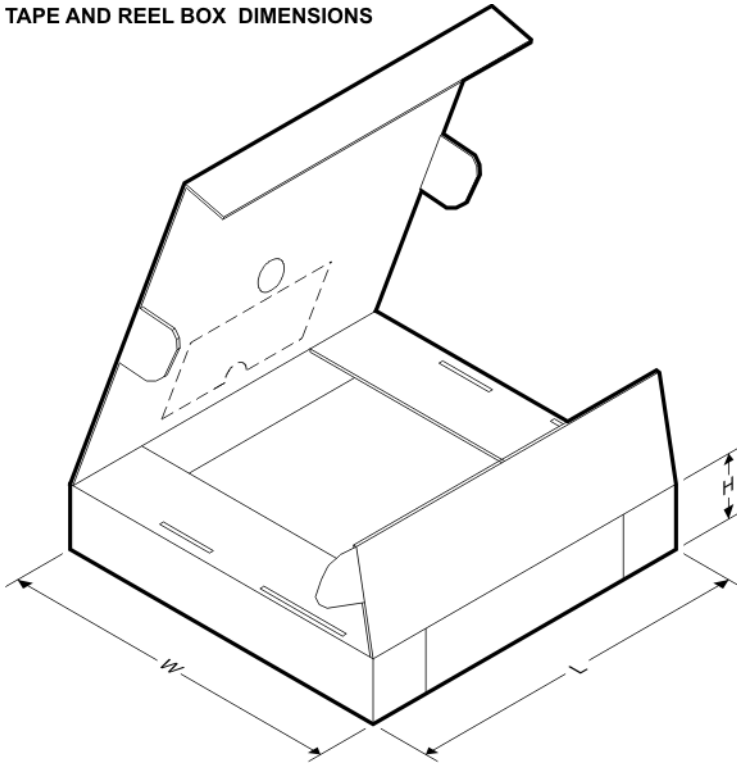
Device	Package Type	Package Drawing	Pins	SPQ	Reel Diameter (mm)	Reel Width W1 (mm)	A0 (mm)	B0 (mm)	K0 (mm)	P1 (mm)	W (mm)	Pin1 Quadrant
TPS65070RSLR	VQFN	RSL	48	2500	330.0	16.4	6.3	6.3	1.1	12.0	16.0	Q2
TPS65070RSLT	VQFN	RSL	48	250	180.0	16.4	6.3	6.3	1.1	12.0	16.0	Q2
TPS65072RSLR	VQFN	RSL	48	2500	330.0	16.4	6.3	6.3	1.1	12.0	16.0	Q2
TPS65072RSLT	VQFN	RSL	48	250	180.0	16.4	6.3	6.3	1.1	12.0	16.0	Q2
TPS65072RSLT	VQFN	RSL	48	250	180.0	16.4	6.3	6.3	1.1	12.0	16.0	Q2
TPS650731RSLR	VQFN	RSL	48	2500	330.0	16.4	6.3	6.3	1.1	12.0	16.0	Q2
TPS650731RSLT	VQFN	RSL	48	250	180.0	16.4	6.3	6.3	1.1	12.0	16.0	Q2
TPS650731RSLT	VQFN	RSL	48	250	180.0	16.4	6.3	6.3	1.1	12.0	16.0	Q2
TPS650732RSLR	VQFN	RSL	48	2500	330.0	16.4	6.3	6.3	1.1	12.0	16.0	Q2
TPS650732RSLT	VQFN	RSL	48	250	180.0	16.4	6.3	6.3	1.1	12.0	16.0	Q2
TPS65073RSLR	VQFN	RSL	48	2500	330.0	16.4	6.3	6.3	1.1	12.0	16.0	Q2
TPS65073RSLR	VQFN	RSL	48	2500	330.0	16.4	6.3	6.3	1.1	12.0	16.0	Q2
TPS65073RSLT	VQFN	RSL	48	250	180.0	16.4	6.3	6.3	1.1	12.0	16.0	Q2
TPS65073RSLT	VQFN	RSL	48	250	180.0	16.4	6.3	6.3	1.1	12.0	16.0	Q2

**TAPE AND REEL BOX DIMENSIONS**

\*All dimensions are nominal

Device	Package Type	Package Drawing	Pins	SPQ	Length (mm)	Width (mm)	Height (mm)
TPS65070RSLR	VQFN	RSL	48	2500	367.0	367.0	38.0
TPS65070RSLT	VQFN	RSL	48	250	210.0	185.0	35.0
TPS65072RSLR	VQFN	RSL	48	2500	367.0	367.0	38.0
TPS65072RSLT	VQFN	RSL	48	250	210.0	185.0	35.0
TPS650731RSLR	VQFN	RSL	48	2500	367.0	367.0	38.0
TPS650731RSLT	VQFN	RSL	48	250	210.0	185.0	35.0
TPS650732RSLR	VQFN	RSL	48	2500	367.0	367.0	38.0
TPS650732RSLT	VQFN	RSL	48	250	210.0	185.0	35.0
TPS65073RSLR	VQFN	RSL	48	2500	367.0	367.0	38.0
TPS65073RSLR	VQFN	RSL	48	2500	367.0	367.0	38.0
TPS65073RSLT	VQFN	RSL	48	250	210.0	185.0	35.0
TPS65073RSLT	VQFN	RSL	48	250	210.0	185.0	35.0

# MECHANICAL DATA

RSL (S-PVQFN-N48)

PLASTIC QUAD FLATPACK NO-LEAD

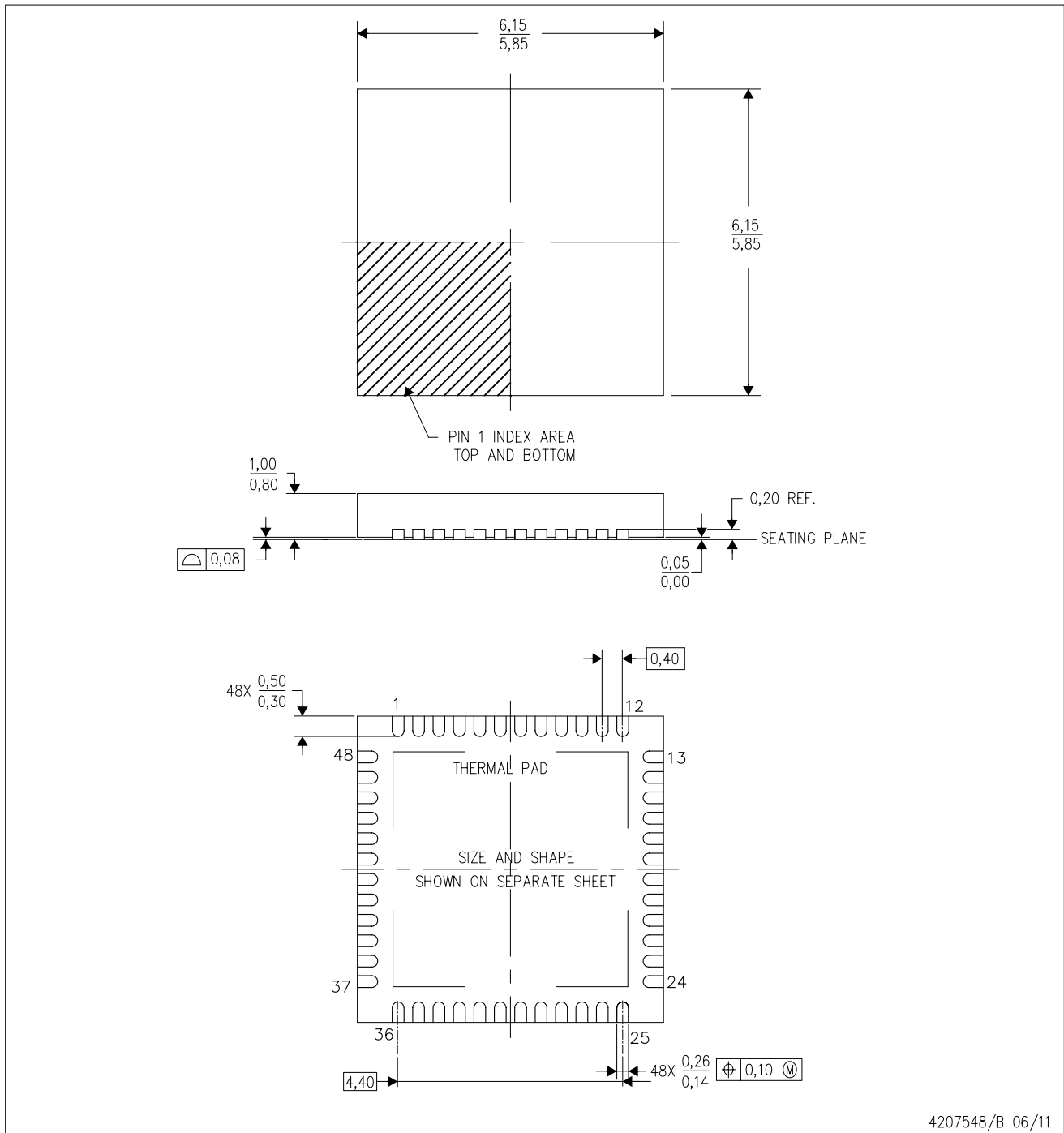

- NOTES:
- All linear dimensions are in millimeters. Dimensioning and tolerancing per ASME Y14.5M-1994.
  - This drawing is subject to change without notice.
  - Quad Flatpack, No-leads (QFN) package configuration.
  - The package thermal pad must be soldered to the board for thermal and mechanical performance.
  - See the additional figure in the Product Data Sheet for details regarding the exposed thermal pad features and dimensions.

# THERMAL PAD MECHANICAL DATA

RSL (S-PVQFN-N48)

PLASTIC QUAD FLATPACK NO-LEAD

## THERMAL INFORMATION

This package incorporates an exposed thermal pad that is designed to be attached directly to an external heatsink. The thermal pad must be soldered directly to the printed circuit board (PCB). After soldering, the PCB can be used as a heatsink. In addition, through the use of thermal vias, the thermal pad can be attached directly to the appropriate copper plane shown in the electrical schematic for the device, or alternatively, can be attached to a special heatsink structure designed into the PCB. This design optimizes the heat transfer from the integrated circuit (IC).

For information on the Quad Flatpack No-Lead (QFN) package and its advantages, refer to Application Report, QFN/SON PCB Attachment, Texas Instruments Literature No. SLUA271. This document is available at [www.ti.com](http://www.ti.com).

The exposed thermal pad dimensions for this package are shown in the following illustration.

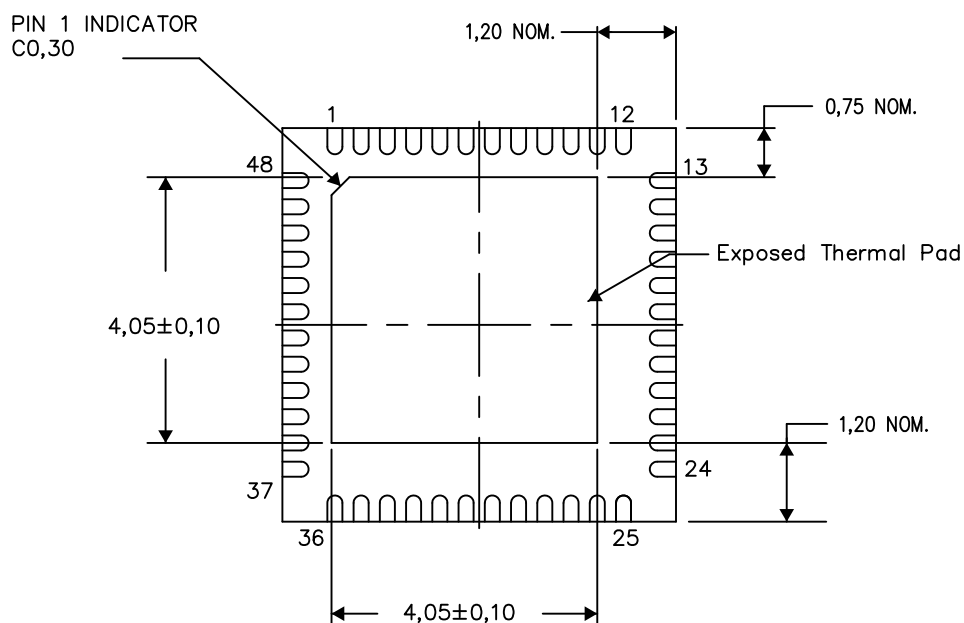

4207841-4/P 03/13

NOTE: All linear dimensions are in millimeters

RSL (S-PVQFN-N48)

PLASTIC QUAD FLATPACK NO-LEAD

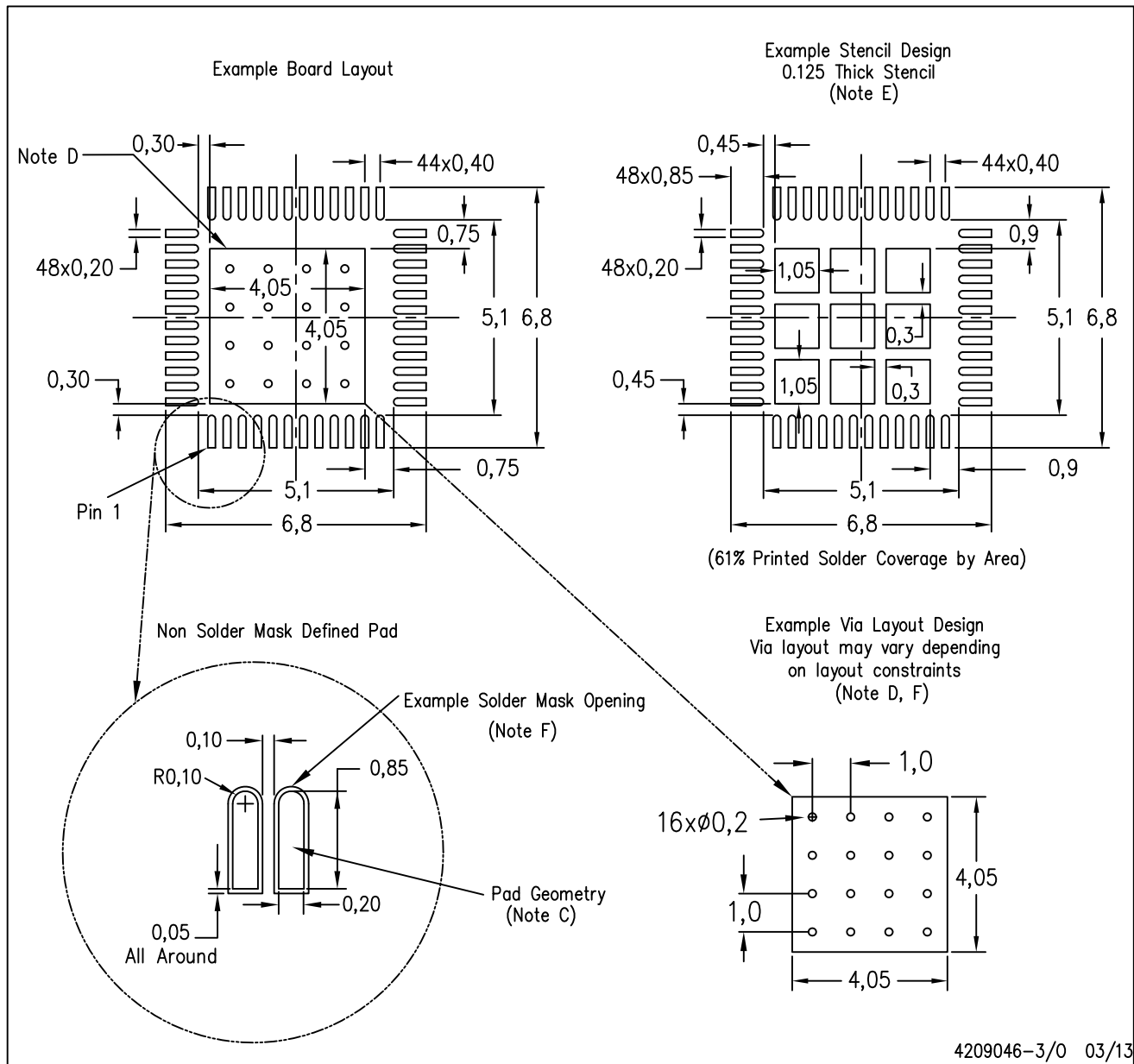

- NOTES:
- A. All linear dimensions are in millimeters.
  - B. This drawing is subject to change without notice.
  - C. Publication IPC-7351 is recommended for alternate designs.
  - D. This package is designed to be soldered to a thermal pad on the board. Refer to Application Note, QFN/SON PCB Attachment, Texas Instruments Literature No. SLUA271, and also the Product Data Sheets for specific thermal information, via requirements, and recommended board layout. These documents are available at [www.ti.com](http://www.ti.com) <<http://www.ti.com>>.
  - E. Laser cutting apertures with trapezoidal walls and also rounding corners will offer better paste release. Customers should contact their board assembly site for stencil design recommendations. Refer to IPC 7525 for stencil design considerations.
  - F. Customers should contact their board fabrication site for recommended solder mask tolerances and via tenting recommendations for vias placed in the thermal pad.

## IMPORTANT NOTICE

Texas Instruments Incorporated (TI) reserves the right to make corrections, enhancements, improvements and other changes to its semiconductor products and services per JESD46, latest issue, and to discontinue any product or service per JESD48, latest issue. Buyers should obtain the latest relevant information before placing orders and should verify that such information is current and complete.

TI's published terms of sale for semiconductor products (<http://www.ti.com/sc/docs/stdterms.htm>) apply to the sale of packaged integrated circuit products that TI has qualified and released to market. Additional terms may apply to the use or sale of other types of TI products and services.

Reproduction of significant portions of TI information in TI data sheets is permissible only if reproduction is without alteration and is accompanied by all associated warranties, conditions, limitations, and notices. TI is not responsible or liable for such reproduced documentation. Information of third parties may be subject to additional restrictions. Resale of TI products or services with statements different from or beyond the parameters stated by TI for that product or service voids all express and any implied warranties for the associated TI product or service and is an unfair and deceptive business practice. TI is not responsible or liable for any such statements.

Buyers and others who are developing systems that incorporate TI products (collectively, "Designers") understand and agree that Designers remain responsible for using their independent analysis, evaluation and judgment in designing their applications and that Designers have full and exclusive responsibility to assure the safety of Designers' applications and compliance of their applications (and of all TI products used in or for Designers' applications) with all applicable regulations, laws and other applicable requirements. Designer represents that, with respect to their applications, Designer has all the necessary expertise to create and implement safeguards that (1) anticipate dangerous consequences of failures, (2) monitor failures and their consequences, and (3) lessen the likelihood of failures that might cause harm and take appropriate actions. Designer agrees that prior to using or distributing any applications that include TI products, Designer will thoroughly test such applications and the functionality of such TI products as used in such applications.

TI's provision of technical, application or other design advice, quality characterization, reliability data or other services or information, including, but not limited to, reference designs and materials relating to evaluation modules, (collectively, "TI Resources") are intended to assist designers who are developing applications that incorporate TI products; by downloading, accessing or using TI Resources in any way, Designer (individually or, if Designer is acting on behalf of a company, Designer's company) agrees to use any particular TI Resource solely for this purpose and subject to the terms of this Notice.

TI's provision of TI Resources does not expand or otherwise alter TI's applicable published warranties or warranty disclaimers for TI products, and no additional obligations or liabilities arise from TI providing such TI Resources. TI reserves the right to make corrections, enhancements, improvements and other changes to its TI Resources. TI has not conducted any testing other than that specifically described in the published documentation for a particular TI Resource.

Designer is authorized to use, copy and modify any individual TI Resource only in connection with the development of applications that include the TI product(s) identified in such TI Resource. NO OTHER LICENSE, EXPRESS OR IMPLIED, BY ESTOPPEL OR OTHERWISE TO ANY OTHER TI INTELLECTUAL PROPERTY RIGHT, AND NO LICENSE TO ANY TECHNOLOGY OR INTELLECTUAL PROPERTY RIGHT OF TI OR ANY THIRD PARTY IS GRANTED HEREIN, including but not limited to any patent right, copyright, mask work right, or other intellectual property right relating to any combination, machine, or process in which TI products or services are used. Information regarding or referencing third-party products or services does not constitute a license to use such products or services, or a warranty or endorsement thereof. Use of TI Resources may require a license from a third party under the patents or other intellectual property of the third party, or a license from TI under the patents or other intellectual property of TI.

TI RESOURCES ARE PROVIDED "AS IS" AND WITH ALL FAULTS. TI DISCLAIMS ALL OTHER WARRANTIES OR REPRESENTATIONS, EXPRESS OR IMPLIED, REGARDING RESOURCES OR USE THEREOF, INCLUDING BUT NOT LIMITED TO ACCURACY OR COMPLETENESS, TITLE, ANY EPIDEMIC FAILURE WARRANTY AND ANY IMPLIED WARRANTIES OF MERCHANTABILITY, FITNESS FOR A PARTICULAR PURPOSE, AND NON-INFRINGEMENT OF ANY THIRD PARTY INTELLECTUAL PROPERTY RIGHTS. TI SHALL NOT BE LIABLE FOR AND SHALL NOT DEFEND OR INDEMNIFY DESIGNER AGAINST ANY CLAIM, INCLUDING BUT NOT LIMITED TO ANY INFRINGEMENT CLAIM THAT RELATES TO OR IS BASED ON ANY COMBINATION OF PRODUCTS EVEN IF DESCRIBED IN TI RESOURCES OR OTHERWISE. IN NO EVENT SHALL TI BE LIABLE FOR ANY ACTUAL, DIRECT, SPECIAL, COLLATERAL, INDIRECT, PUNITIVE, INCIDENTAL, CONSEQUENTIAL OR EXEMPLARY DAMAGES IN CONNECTION WITH OR ARISING OUT OF TI RESOURCES OR USE THEREOF, AND REGARDLESS OF WHETHER TI HAS BEEN ADVISED OF THE POSSIBILITY OF SUCH DAMAGES.

Unless TI has explicitly designated an individual product as meeting the requirements of a particular industry standard (e.g., ISO/TS 16949 and ISO 26262), TI is not responsible for any failure to meet such industry standard requirements.

Where TI specifically promotes products as facilitating functional safety or as compliant with industry functional safety standards, such products are intended to help enable customers to design and create their own applications that meet applicable functional safety standards and requirements. Using products in an application does not by itself establish any safety features in the application. Designers must ensure compliance with safety-related requirements and standards applicable to their applications. Designer may not use any TI products in life-critical medical equipment unless authorized officers of the parties have executed a special contract specifically governing such use. Life-critical medical equipment is medical equipment where failure of such equipment would cause serious bodily injury or death (e.g., life support, pacemakers, defibrillators, heart pumps, neurostimulators, and implantables). Such equipment includes, without limitation, all medical devices identified by the U.S. Food and Drug Administration as Class III devices and equivalent classifications outside the U.S.

TI may expressly designate certain products as completing a particular qualification (e.g., Q100, Military Grade, or Enhanced Product). Designers agree that it has the necessary expertise to select the product with the appropriate qualification designation for their applications and that proper product selection is at Designers' own risk. Designers are solely responsible for compliance with all legal and regulatory requirements in connection with such selection.

Designer will fully indemnify TI and its representatives against any damages, costs, losses, and/or liabilities arising out of Designer's non-compliance with the terms and provisions of this Notice.

## Looking for pricing, stock, or lifecycle information?

Click below to explore more details on WIN SOURCE:

 [View TPS65072RSLR on WIN SOURCE](#)

 [Texas Instruments](#) Information

## Optimize Your Supply Chain with WIN SOURCE Solutions

-  Global Sourcing Solution
-  Obsolete Management
-  Cost Control Management
-  Shortage Management
-  Alternative Solution
-  Excess Inventory Management