



**THE DATASHEET OF
AD596AH**



FEATURES

- Low Cost**
- Operates with Type J (AD596) or Type K (AD597) Thermocouples**
- Built-In Ice Point Compensation**
- Temperature Proportional Operation – 10 mV/°C**
- Temperature Setpoint Operation – ON/OFF**
- Programmable Switching Hysteresis**
- High Impedance Differential Input**

GENERAL DESCRIPTION

The AD596/AD597 is a monolithic temperature setpoint controller that has been optimized for use at elevated temperatures such as those found in oven control applications. The device cold junction compensates and amplifies a type J or K thermocouple input to derive an internal signal proportional to temperature. The internal signal is then compared with an externally applied setpoint voltage to yield a low impedance switched output voltage. Dead-Band or switching hysteresis can be programmed using a single external resistor. Alternately, the AD596/AD597 can be configured to provide a voltage output (10 mV/°C) directly from a type J or K thermocouple signal. It can also be used as a stand-alone voltage output temperature sensor.

The AD596/AD597 can be powered with a single supply from +5 V to +30 V, or dual supplies up to a total span of 36 V. Typical quiescent supply current is 160 μ A, which minimizes self-heating errors.

The AD596/AD597 H package option includes a thermocouple failure alarm that indicates an open thermocouple lead when operated in the temperature proportional measurement mode. The alarm output has a flexible format which can be used to drive relays, LEDs or TTL logic.

The device is packaged in a reliability qualified, cost effective 10-pin metal can or SOIC and is trimmed to operate over an ambient temperature range from +25°C to +100°C. Operation over an extended ambient temperature range is possible with slightly reduced accuracy. The AD596 will amplify thermocouple signals covering the entire -200°C to +760°C temperature range recommended for type J thermocouples while the AD597 can accommodate -200°C to +1250°C type K inputs.

The AD596/AD597 has a calibration accuracy of $\pm 4^\circ\text{C}$ at an ambient temperature of 60°C and an ambient temperature stability specification of 0.05°C/°C from +25°C to +100°C. If higher accuracy, or a lower ambient operating temperature is required, either the AD594 (J thermocouple) or AD595 (K thermocouple) should be considered.

REV. B

Information furnished by Analog Devices is believed to be accurate and reliable. However, no responsibility is assumed by Analog Devices for its use, nor for any infringements of patents or other rights of third parties which may result from its use. No license is granted by implication or otherwise under any patent or patent rights of Analog Devices.

FUNCTIONAL BLOCK DIAGRAM

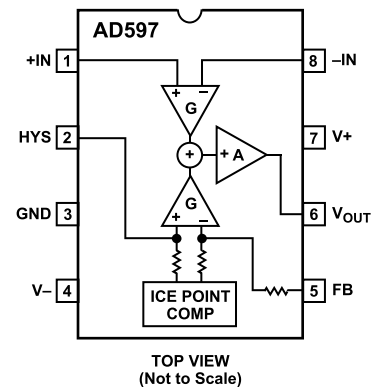
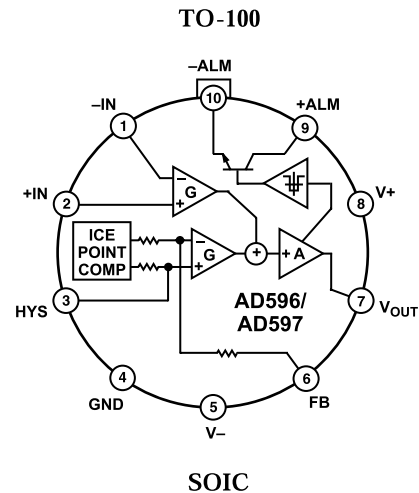

PRODUCT HIGHLIGHTS

1. The AD596/AD597 provides cold junction compensation and a high gain amplifier which can be used as a setpoint comparator.
2. The input stage of the AD596/AD597 is a high quality instrumentation amplifier that allows the thermocouple to float over most of the supply voltage range.
3. Linearization not required for thermocouple temperatures close to 175°C (+100°C to +540°C for AD596).
4. Cold junction compensation is optimized for ambient temperatures ranging from +25°C to +100°C.
5. In the stand-alone mode, the AD596/AD597 produces an output voltage that indicates its own temperature.

AD596/AD597—SPECIFICATIONS (@ +60°C and $V_S = 10\text{ V}$, Type J (AD596), Type K (AD597) Thermocouple, unless otherwise noted)

Model	AD596AH			AD597AH			AD597AR			Units	
	Min	Typ	Max	Min	Typ	Max	Min	Typ	Max		
ABSOLUTE MAXIMUM RATINGS											
+ V_S to $-V_S$			36			36			36	Volts	
Common-Mode Input Voltage	$(-V_S - 0.15)$		$+V_S$	$(-V_S - 0.15)$		$+V_S$	$(-V_S - 0.15)$		$+V_S$	Volts	
Differential Input Voltage	$-V_S$		$+V_S$	$-V_S$		$+V_S$	$-V_S$		$+V_S$	Volts	
Alarm Voltages											
+ALM	$-V_S$		$(-V_S + 36)$	$-V_S$		$(-V_S + 36)$	$-V_S$		$(-V_S + 36)$	Volts	
-ALM	$-V_S$		$+V_S$	$-V_S$		$+V_S$	$-V_S$		$+V_S$	Volts	
Operating Temperature Range	-55		+125	-55		+125	-40		+125	°C	
Output Short Circuit to Common	Indefinite			Indefinite			Indefinite				
TEMPERATURE MEASUREMENT (Specified Temperature Range +25°C to +100°C)											
Calibration Error ¹	-4		+4	-4		+4	-4		+4	°C	
Stability vs. Temperature ²		± 0.02	± 0.05		± 0.02	± 0.05		± 0.02	± 0.05	°C/°C	
Gain Error	-1.5		+1.5	-1.5		+1.5	-1.5		+1.5	%	
Nominal Transfer Function		10			10			10		mV/°C	
AMPLIFIER CHARACTERISTICS											
Closed Loop Gain ³		180.6			245.5			245.5		V/V	
Input Offset Voltage		$^{\circ}\text{C} \times 53.21 + 235$			$^{\circ}\text{C} \times 41.27 - 37$			$^{\circ}\text{C} \times 41.27 - 37$		μV	
Input Bias Current		0.1			0.1			0.1		μA	
Differential Input Range	-10		+50	-10		+50	-10		+50	mV	
Common-Mode Range	$(-V_S - 0.15)$		$(+V_S - 4)$	$(+V_S - 0.15)$		$(+V_S - 4)$	$(-V_S - 0.15)$		$(+V_S - 4)$	Volts	
Common-Mode Sensitivity-RTO			10			10			10	mV/V	
Power Supply Sensitivity-RTO		1	10		1	10		1	10	mV/V	
Output Voltage Range											
Dual Supplies	$(-V_S + 2.5)$		$(+V_S - 2)$	$(-V_S + 2.5)$		$(+V_S - 2)$	$(-V_S + 2.5)$		$(+V_S - 2)$	Volts	
Single Supply	0		$(+V_S - 2)$	0		$(+V_S - 2)$	0		$(+V_S - 2)$	Volts	
Usable Output Current ⁴		± 5			± 5			± 5		mA	
3 dB Bandwidth		15			15			15		kHz	
ALARM CHARACTERISTICS⁵											
$V_{CE(SAT)}$ at 2 mA		0.3			0.3		Alarm Function Not Pinned Out			Volts	
Leakage Current			± 1			± 1				μA	
Operating Voltage at -ALM			$(+V_S - 4)$			$(+V_S - 4)$				Volts	
Short Circuit Current		20			20					mA	
POWER REQUIREMENTS											
Operating		$(+V_S \text{ to } -V_S) \leq 30$			$(+V_S \text{ to } -V_S) \leq 30$			$(+V_S \text{ to } -V_S) \leq 30$			Volts
Quiescent Current											
+ V_S		160	300		160	300		160	300	μA	
$-V_S$		100	200		100	200		100	200	μA	

NOTES

¹This is a measure of the deviation from ideal with a measuring thermocouple junction of 175°C and a chip temperature of 60°C. The ideal transfer function is given by:

$$\text{AD596: } V_{\text{OUT}} = 180.57 \times (V_m - V_a + (\text{ambient in } ^{\circ}\text{C}) \times 53.21 \mu\text{V}/^{\circ}\text{C} + 235 \mu\text{V})$$

$$\text{AD597: } V_{\text{OUT}} = 245.46 \times (V_m - V_a + (\text{ambient in } ^{\circ}\text{C}) \times 41.27 \mu\text{V}/^{\circ}\text{C} - 37 \mu\text{V})$$

where V_m and V_a represent the measuring and ambient temperatures and are taken from the appropriate J or K thermocouple table. The ideal transfer function minimizes the error over the ambient temperature range of 25°C to 100°C with a thermocouple temperature of approximately 175°C.

²Defined as the slope of the line connecting the AD596/AD597 CJC errors measured at 25°C and 100°C ambient temperature.

³Pin 6 shorted to Pin 7.

⁴Current Sink Capability in single supply configuration is limited to current drawn to ground through a 50 k Ω resistor at output voltages below 2.5 V.

⁵Alarm function available on H package option only.

Specifications subject to change without notice.

Specifications shown in **boldface** are tested on all production units at final electrical test. Results from those tests are used to calculate outgoing quality levels. All min and max specifications are guaranteed, although only those shown in boldface are tested on all production units.

ORDERING GUIDE

Model	Package Description	Package Options
AD596AH	TO-100	H-10A
AD597AH	TO-100	H-10A
AD597AR*	Plastic SOIC	SO-8

*Consult factory for availability.

Table I. Output Voltage vs. Thermocouple Temperature (Ambient +60°C, $V_S = -5\text{ V}, +15\text{ V}$)

Thermocouple Temperature °C	Type J Voltage mV	AD596 Output mV	Type K Voltage mV	AD597 Output mV	Thermocouple Temperature °C	Type J Voltage mV	AD596 Output mV	Type K Voltage mV	AD597 Output mV
-200	-7.890	-1370	-5.891	-1446	500	27.388	5000	20.640	5066
-180	-7.402	-1282	-5.550	-1362	520	28.511	5203	21.493	5276
-160	-6.821	-1177	-5.141	-1262	540	29.642	5407	22.346	5485
-140	-6.159	-1058	-4.669	-1146	560	30.782	5613	23.198	5694
-120	-5.426	-925	-4.138	-1016	580	31.933	5821	24.050	5903
-100	-4.632	-782	-3.553	-872	600	33.096	6031	24.902	6112
-80	-3.785	-629	-2.920	-717	620	34.273	6243	25.751	6321
-60	-2.892	-468	-2.243	-551	640	35.464	6458	26.599	6529
-40	-1.960	-299	-1.527	-375	660	36.671	6676	27.445	6737
-20	-.995	-125	-.777	-191	680	37.893	6897	28.288	6944
-10	-.501	-36	-.392	-96	700	39.130	7120	29.128	7150
0	0	54	0	0	720	40.382	7346	29.965	7355
10	.507	146	.397	97	740	41.647	7575	30.799	7560
20	1.019	238	.798	196	750	42.283	7689	31.214	7662
25	1.277	285	1.000	245	760	-	-	31.629	7764
30	1.536	332	1.203	295	780	-	-	32.455	7966
40	2.058	426	1.611	395	800	-	-	33.277	8168
50	2.585	521	2.022	496	820	-	-	34.095	8369
60	3.115	617	2.436	598	840	-	-	34.909	8569
80	4.186	810	3.266	802	860	-	-	35.718	8767
100	5.268	1006	4.095	1005	880	-	-	36.524	8965
120	6.359	1203	4.919	1207	900	-	-	37.325	9162
140	7.457	1401	5.733	1407	920	-	-	38.122	9357
160	8.560	1600	6.539	1605	940	-	-	38.915	9552
180	9.667	1800	7.338	1801	960	-	-	39.703	9745
200	10.777	2000	8.137	1997	980	-	-	40.488	9938
220	11.887	2201	8.938	2194	1000	-	-	41.269	10130
240	12.998	2401	9.745	2392	1020	-	-	42.045	10320
260	14.108	2602	10.560	2592	1040	-	-	42.817	10510
280	15.217	2802	11.381	2794	1060	-	-	43.585	10698
300	16.325	3002	12.207	2996	1080	-	-	44.339	10908
320	17.432	3202	13.039	3201	1100	-	-	45.108	11072
340	18.537	3402	13.874	3406	1120	-	-	45.863	11258
360	19.640	3601	14.712	3611	1140	-	-	46.612	11441
380	20.743	3800	15.552	3817	1160	-	-	47.356	11624
400	21.846	3999	16.395	4024	1180	-	-	48.095	11805
420	22.949	4198	17.241	4232	1200	-	-	48.828	11985
440	24.054	4398	18.088	4440	1220	-	-	49.555	12164
460	25.161	4598	18.938	4649	1240	-	-	50.276	12341
480	26.272	4798	19.788	4857	1250	-	-	50.633	12428

AD596/AD597

TEMPERATURE PROPORTIONAL OUTPUT MODE

The AD596/AD597 can be used to generate a temperature proportional output of 10 mV/°C when operated with J and K type thermocouples as shown in Figure 1. Thermocouples produce low level output voltages which are a function of both the temperature being measured and the reference or cold junction temperature. The AD596/AD597 compensates for the cold junction temperature and amplifies the thermocouple signal to produce a high level 10 mV/°C voltage output which is a function only of the temperature being measured. The temperature stability of the part indicates the sensitivity of the output voltage to changes in ambient or device temperatures. This is typically 0.02°C/°C over the +25°C to +100°C recommended ambient temperature range. The parts will operate over the extended ambient temperature ranges from -55°C to +125°C, but thermocouple nonlinearity at the reference junction will degrade the temperature stability over this extended range. Table I is a list of ideal AD596/AD597 output voltages as a function of Celsius temperature for type J and K ANSI standard thermocouples with package and reference junction at 60°C. As is normally the case, these outputs are subject to calibration and temperature sensitivity errors. These tables are derived using the ideal transfer functions:

$$\begin{aligned} \text{AD596 output} &= (\text{Type J voltage} + 301.5 \mu\text{V}) \times 180.57 \\ \text{AD597 output} &= (\text{Type K voltage}) \times 245.46 \end{aligned}$$

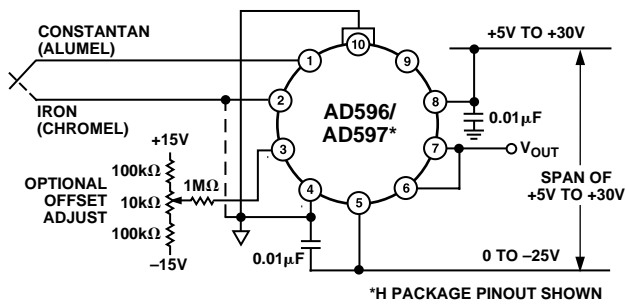

Figure 1. Temperature Proportional Output Connection

The offsets and gains of these devices have been laser trimmed to closely approximate thermocouple characteristics over measurement temperature ranges centered around 175°C with the AD596/AD597 at an ambient temperature between 25°C and 100°C. This eliminates the need for additional gain or offset adjustments to make the output voltage read:

$$V_{\text{OUT}} = 10 \text{ mV/}^\circ\text{C} \times (\text{thermocouple temperature in } ^\circ\text{C}) \text{ (within specified tolerances).}$$

Excluding calibration errors, the above transfer function is accurate to within 1°C from +80°C to +550°C for the AD596 and -20°C to +350°C for the AD597. The different temperature ranges are due to the differences in J and K type thermocouple curves.

European DIN FE-CuNi thermocouple vary slightly from ANSI type J thermocouples. Table I does not apply when these types of thermocouples are used. The transfer functions given previously and a thermocouple table should be used instead.

Figure 1 also shows an optional trimming network which can be used to change the device's offset voltage. Injecting or sinking 200 nA from Pin 3 will offset the output approximately 10 mV (1°C).

The AD596/AD597 can operate from a single supply from 5 V to 36 V or from split supplies totalling 36 V or less as shown. Since the output can only swing to within 2 V of the positive supply, the usable measurement temperature range will be restricted when positive supplies less than 15 V for the AD597 and 10 V for the AD596 are used. If the AD596/AD597 is to be used to indicate negative Celsius temperatures, then a negative supply is required.

Common-mode voltages on the thermocouple inputs must remain within the common-mode voltage range of the AD596/AD597, with a return path provided for the bias currents. If the thermocouple is not remotely grounded, then the dotted line connection shown in Figure 1 must be made to one of the thermocouple inputs. If there is no return path for the bias currents, the input stage will saturate, causing erroneous output voltages.

In this configuration, the AD596/AD597 H package option has circuitry which detects the presence of an open thermocouple. If the thermocouple loop becomes open, one or both of the inputs to the device will be deprived of bias current causing the output to saturate. It is this saturation which is detected internally and used to activate the alarm circuitry. The output of this feature has a flexible format which can be used to source or sink up to 20 mA of current. The collector (+ALM) should not be allowed to become more positive than $(-V_S + 36 \text{ V})$, however, it may be permitted to be more positive than $+V_S$. The emitter voltage (-ALM) should be constrained such that it does not become more positive than 4 V below $+V_S$. If the alarm feature is not used, this pin should be connected to Pins 4 or 5 as shown in Figure 1. The alarm function is unavailable on the AR package option.

SETPOINT CONTROL MODE

The AD596/AD597 can be connected as a setpoint controller as shown in Figure 2. The thermocouple voltage is cold junction compensated, amplified, and compared to an external setpoint voltage. The relationship between setpoint voltage and temperature is given in Table I. If the temperature to be controlled is within the operating range (-55°C to +125°C) of the device, it can monitor its own temperature by shorting the inputs to ground. The setpoint voltage with the thermocouple inputs grounded is given by the expressions:

$$\begin{aligned} \text{AD596 Setpoint Voltage} &= ^\circ\text{C} \times 9.6 \text{ mV}/^\circ\text{C} + 42 \text{ mV} \\ \text{AD597 Setpoint Voltage} &= ^\circ\text{C} \times 10.1 \text{ mV}/^\circ\text{C} - 9.1 \text{ mV} \end{aligned}$$

The input impedance of the setpoint pin of the AD596/AD597 is approximately 50 kΩ. The temperature coefficient of this resistance is ±15 ppm/°C. Therefore, the 100 ppm/°C 5 kΩ pot shown in Figure 2 will only introduce an additional ±1°C degradation of temperature stability over the +25°C to +100°C ambient temperature range.

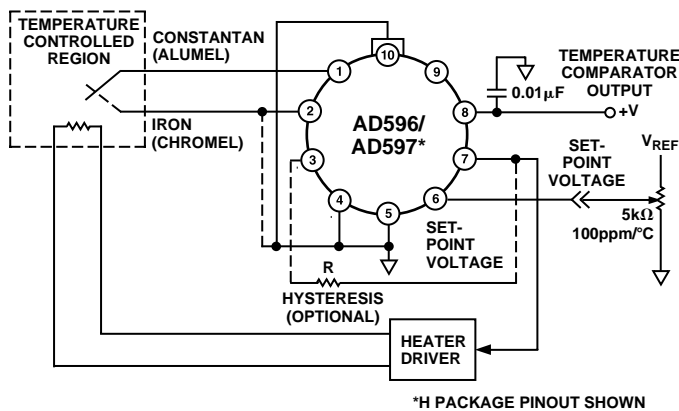

Figure 2. Setpoint Control Mode

Switching hysteresis is often used in setpoint systems of this type to provide noise immunity and increase system reliability. By reducing the frequency of on-off cycling, mechanical component wear is reduced leading to enhanced system reliability. This can easily be implemented with a single external resistor between Pins 7 and 3 of the AD596/AD597. Each 200 nA of current injected into Pin 3 when the output switches will cause about 1°C of hysteresis; that is:

$$R_{HYST} (\Omega) = \frac{V_{OUT}}{200 \text{ nA}} \times \frac{1}{^\circ\text{C}_{HYST}}$$

In the setpoint configuration, the AD596/AD597 output is saturated at all times, so the alarm transistor will be ON regardless of whether there is an open circuit or not. However, -ALM must be tied to a voltage below (+V_S - 4 V) for proper operation of the rest of the circuit.

STAND-ALONE TEMPERATURE TRANSDUCER

The AD596/AD597 may be configured as a stand-alone Celsius thermometer as shown in Figure 3.

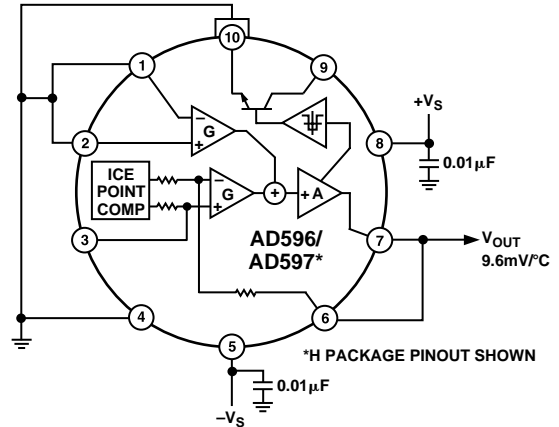

Figure 3. Stand-Alone Temperature Transducer Temperature Proportional Output Connection

Simply omit the thermocouple and connect the inputs (Pins 1 and 2) to common. The output will now reflect the compensation voltage and hence will indicate the AD596/AD597 temperature. In this three terminal, voltage output, temperature sensing mode, the AD596/AD597 will operate over the full extended -55°C to +125°C temperature range. The output scaling will be 9.6 mV per °C with the AD596 and 10.1 mV per °C with the AD597. Additionally there will be a 42 mV offset with the AD596 causing it to read slightly high when used in this mode.

THERMOCOUPLE CONNECTIONS

The connection of the thermocouple wire and the normal wire or printed circuit board traces going to the AD596/AD597 forms an effective reference junction as shown in Figure 4. This junction must be kept at the same temperature as the AD596/AD597 for the internal cold junction compensation to work properly. Unless the AD596/AD597 is in a thermally stable enclosure, the thermocouple leads should be brought in directly to Pins 1 and 2.

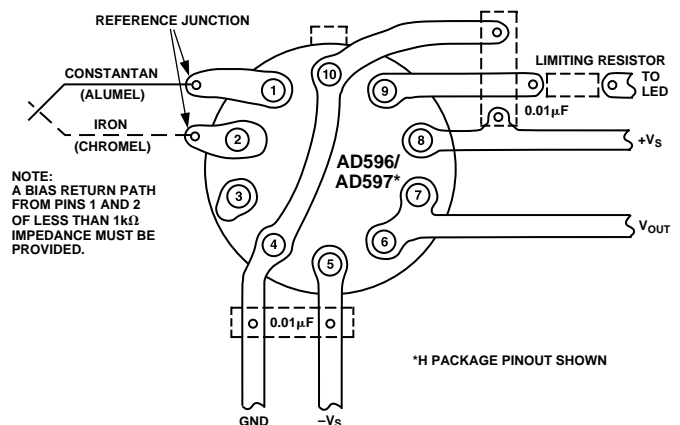

Figure 4. PCB Connections

To ensure secure bonding, the thermocouple wire should be cleaned to remove oxidization prior to soldering. Noncorrosive resin flux is effective with iron, constantan, chromel, and alumel, and the following solders: 95% tin-5% silver, or 90% tin-10% lead.

AD596/AD597

SINGLE AND DUAL SUPPLY CONNECTIONS

In the single supply configuration as used in the setpoint controller of Figure 2, any convenient voltage from +5 V to +36 V may be used, with self-heating errors being minimized at lower supply levels. In this configuration, the $-V_S$ connection at Pin 5 is tied to ground. Temperatures below zero can be accommodated in the single supply setpoint mode, but not in the single supply temperature measuring mode (Figure 1 reconnected for single supply). Temperatures below zero can only be indicated by a negative output voltage, which is impossible in the single supply mode.

Common-mode voltages on the thermocouple inputs must remain below the positive supply, and not more than 0.15 V more negative than the minus supply. In addition, a return path for the input bias currents must be provided. If the thermocouple is not remotely grounded, then the dotted line connections in Figures 1 and 2 are mandatory.

STABILITY OVER TEMPERATURE

The AD596/AD597 is specified for a maximum error of $\pm 4^\circ\text{C}$ at an ambient temperature of 60°C and a measuring junction temperature at 175°C . The ambient temperature stability is specified to be a maximum of $0.05^\circ\text{C}/^\circ\text{C}$. In other words, for every degree change in the ambient temperature, the output will change no more than 0.05 degrees. So, at 25°C the maximum deviation from the temperature-voltage characteristic of Table I is $\pm 5.75^\circ\text{C}$, and at 100°C it is $\pm 6^\circ\text{C}$ maximum (see Figure 5). If the offset error of $\pm 4^\circ\text{C}$ is removed with a single offset adjustment, these errors will be reduced to $\pm 1.75^\circ\text{C}$ and $\pm 2^\circ\text{C}$ max. The optional trim circuit shown in Figure 1 demonstrates how the ambient offset error can be adjusted to zero.

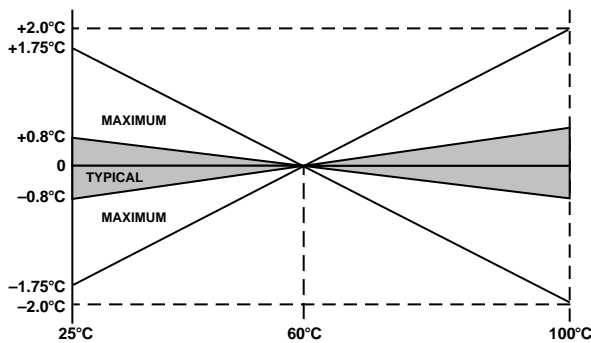

Figure 5. Drift Error vs. Temperature

THERMAL ENVIRONMENTAL EFFECTS

The inherent low power dissipation of the AD596/AD597 keeps self-heating errors to a minimum. However, device output is capable of delivering ± 5 mA to an external load and the alarm circuitry can supply up to 20 mA. Since the typical junction to ambient thermal resistance in free air is $150^\circ\text{C}/\text{W}$, significant temperature difference between the package pins (where the reference junction is located) and the chip (where the cold junction temperature is measured and then compensated) can exist when the device is operated in a high dissipation mode. These

temperature differences will result in a direct error at the output. In the temperature proportional mode, the alarm feature will only activate in the event of an open thermocouple or system transient which causes the device output to saturate. Self-Heating errors will not effect the operation of the alarm but two cases do need to be considered. First, after a fault is corrected and the alarm is reset, the AD596/AD597 must be allowed to cool before readings can again be accurate. This can take 5 minutes or more depending upon the thermal environment seen by the device. Second, the junction temperature of the part should not be allowed to exceed 150°C . If the alarm circuit of the AD596/AD597 is made to source or sink 20 mA with 30 V across it, the junction temperature will be 90°C above ambient causing the die temperature to exceed 150°C when ambient is above 60°C . In this case, either the load must be reduced, or a heat sink used to lower the thermal resistance.

TEMPERATURE READOUT AND CONTROL

Figure 6 shows a complete temperature indication and control system based on the AD596/AD597. Here the AD596/AD597 is being used as a closed-loop thermocouple signal conditioner and an external op amp is used to implement setpoint. This has two important advantages. It provides a high level ($10\text{ mV}/^\circ\text{C}$) output for the A/D panel meter and also preserves the alarm function for open thermocouples.

The A/D panel meter can easily be offset and scaled as shown to read directly in degrees Fahrenheit. If a two temperature calibration scheme is used, the dominant residual errors will arise from two sources; the ambient temperature rejection (typically $\pm 2^\circ\text{C}$ over a 25°C to 100°C range) and thermocouple nonlinearity typical $+1^\circ\text{C}$ from 80°C to 550°C for type J and $+1^\circ\text{C}$ from -20°C to 350°C for type K.

An external voltage reference is used both to increase the stability of the A/D converter and supply a stable reference for the setpoint voltage.

A traditional requirement for the design of setpoint control thermocouple systems has been to configure the system such that the appropriate action is taken in the event of an open thermocouple. The open thermocouple alarm pin with its flexible current-limited output format supports this function when the part operates in the temperature proportional mode. In addition, if the thermocouple is not remotely grounded, it is possible to program the device for either a positive or negative full-scale output in the event of an open thermocouple. This is done by connecting the bias return resistor directly to Pin 1 if a high output voltage is desired to indicate a fault condition. Alternately, if the bias return is provided on the thermocouple lead connected to Pin 2, an open circuit will result in an output low reading. Figure 6 shows the ground return connected to Pin 1 so that if the thermocouple fails, the heater will remain off. At the same time, the alarm circuit lights the LED signalling the need to service the thermocouple. Grounding Pin 2 would lead to low output voltage saturation, and in this circuit would result in a potentially dangerous thermal runaway under fault conditions.

OUTLINE DIMENSIONS

Dimensions shown in inches and (mm).

**10-Pin Metal Can
(TO-100)**

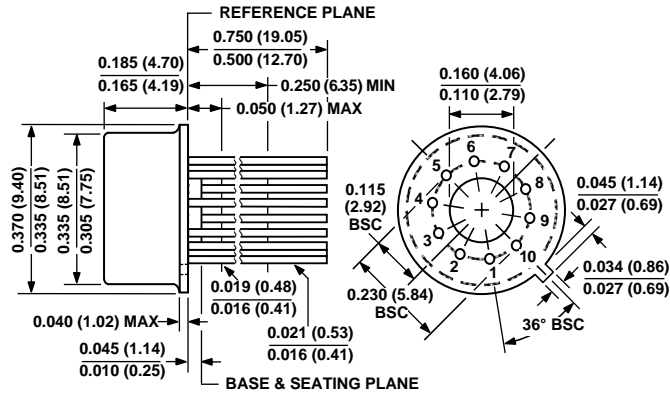

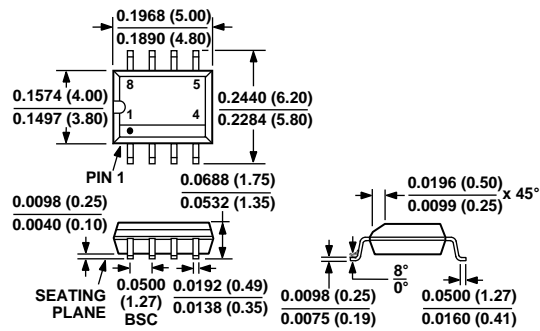

**8-Lead Small Outline (SOIC)
(SO-8)**



Looking for pricing, stock, or lifecycle information?

Click below to explore more details on WIN SOURCE:

-  [View AD596AH on WIN SOURCE](#)
-  [Analog Devices Inc. Information](#)

Optimize Your Supply Chain with WIN SOURCE Solutions

-  Global Sourcing Solution
-  Obsolete Management
-  Cost Control Management
-  Shortage Management
-  Alternative Solution
-  Excess Inventory Management