



**THE DATASHEET OF  
IXKH47N60C**



# CoolMOS™ 1) Power MOSFET

Low  $R_{DS(on)}$ , high  $V_{DSS}$   
Superjunction MOSFET

$V_{DSS} = 600\text{ V}$   
 $I_{D25} = 47\text{ A}$   
 $R_{DS(on) \text{ max}} = 70\text{ m}\Omega$

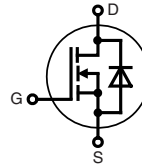
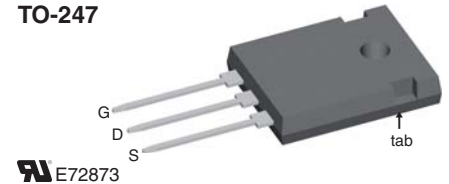
**TO-247**

MOSFET			
Symbol	Conditions	Maximum Ratings	
$V_{DSS}$	$T_{VJ} = 25^\circ\text{C}$	600	V
$V_{GS}$		$\pm 20$	V
$I_{D25}$	$T_C = 25^\circ\text{C}$	47	A
$I_{D100}$	$T_C = 100^\circ\text{C}$	30	A
$E_{AS}$	single pulse $I_D = 10\text{ A}; T_C = 25^\circ\text{C}$	1800	mJ
$E_{AR}$	repetitive $I_D = 20\text{ A}; T_C = 25^\circ\text{C}$	tbd	mJ
$dV/dt$	MOSFET $dV/dt$ ruggedness $V_{DS} = 0 \dots 480\text{ V}$	tbd	V/ns

**Features**

- 3rd generation Superjunction power MOSFET
- high blocking capability
- lowest resistance
- avalanche rated for unclamped inductive switching (UIS)
- low thermal resistance due to reduced chip thickness

**Applications**

- Switched mode power supplies (SMPS)
- Uninterruptible power supplies (UPS)
- Power factor correction (PFC)
- Welding
- Inductive heating

Symbol	Conditions	Characteristic Values			
		$(T_{VJ} = 25^\circ\text{C}, \text{ unless otherwise specified})$			
		min.	typ.	max.	
$R_{DS(on)}$	$V_{GS} = 10\text{ V}; I_D = I_{D100} \text{ }^\ominus$		60	70	m $\Omega$
$V_{GS(th)}$	$V_{DS} = V_{GS}; I_D = 2\text{ mA}$	2		4	V
$I_{DSS}$	$V_{DS} = V_{DSS}; V_{GS} = 0\text{ V}$			25	$\mu\text{A}$
				250	$\mu\text{A}$
$I_{GSS}$	$V_{GS} = \pm 20\text{ V}; V_{DS} = 0\text{ V}$			$\pm 100$	nA
$C_{iss}$	} $V_{GS} = 0\text{ V}; V_{DS} = 100\text{ V}$ $f = 1\text{ MHz}$		tbd		pF
$C_{oss}$				tbd	
$Q_g$	} $V_{GS} = 0\text{ to }10\text{ V}; V_{DS} = 350\text{ V}; I_D = 40\text{ A}$		255	650	nC
$Q_{gs}$			30		nC
$Q_{gd}$			110		nC
$t_{d(on)}$	} $V_{GS} = 10\text{ V}; V_{DS} = 380\text{ V}$ $I_D = 47\text{ A}; R_G = 4.7\ \Omega$		20		ns
$t_r$			27		ns
$t_{d(off)}$			111		ns
$t_f$			10		ns
$R_{thJC}$				0.3	K/W

$^\ominus$  Pulse test,  $t \leq 300\ \mu\text{s}$ , duty cycle  $d \leq 2\%$

<sup>1)</sup> CoolMOS™ is a trademark of Infineon Technologies AG.

## Source-Drain Diode

Symbol	Conditions	Characteristic Values		
		min.	typ.	max.
$I_S$	$V_{GS} = 0 V$			A
$V_{SD}$	$I_F = 40 A; V_{GS} = 0 V$			V
$t_{rr}$ $Q_{RM}$ $I_{RM}$	} $I_F = 40 A; -di_F/dt = 100 A/\mu s; V_R = 640 V$			ns $\mu C$ A

( $T_{VJ} = 25^\circ C$ , unless otherwise specified)

## Component

Symbol	Conditions	Maximum Ratings	
$T_{VJ}$	operating	-55...+150	$^\circ C$
$T_{stg}$		-55...+150	$^\circ C$
$M_d$	mounting torque	1.13	Nm

Symbol	Conditions	Characteristic Values		
		min.	typ.	max.
$R_{thCH}$	with heatsink compound		tdb	K/W
Weight			2.7	g

## TO-247 Outline

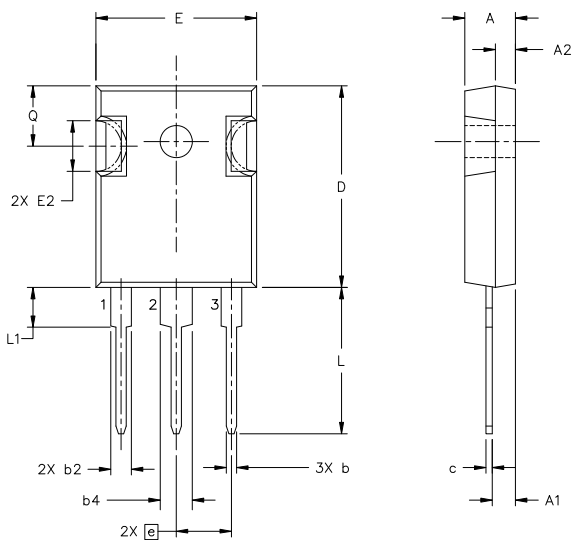

Symbol	Inches		Millimeters	
	min	max	min	max
A	0.185	0.209	4.70	5.30
A1	0.087	0.102	2.21	2.59
A2	0.059	0.098	1.50	2.49
D	0.819	0.845	20.79	21.45
E	0.610	0.640	15.48	16.24
E2	0.170	0.216	4.31	5.48
e	0.215 BSC		5.46 BSC	
L	0.780	0.800	19.80	20.30
L1	-	0.177	-	4.49
$\emptyset P$	0.140	0.144	3.55	3.65
Q	0.212	0.244	5.38	6.19
S	0.242 BSC		6.14 BSC	
b	0.039	0.055	0.99	1.40
b2	0.065	0.094	1.65	2.39
b4	0.102	0.135	2.59	3.43
c	0.015	0.035	0.38	0.89
D1	0.515	-	13.07	-
D2	0.020	0.053	0.51	1.35
E1	0.530	-	13.45	-
$\emptyset P1$	-	0.291	-	7.39

IXYS reserves the right to change limits, test conditions and dimensions.

20080523a

**Fig. 1. Output Characteristics @ 25 Deg. C**

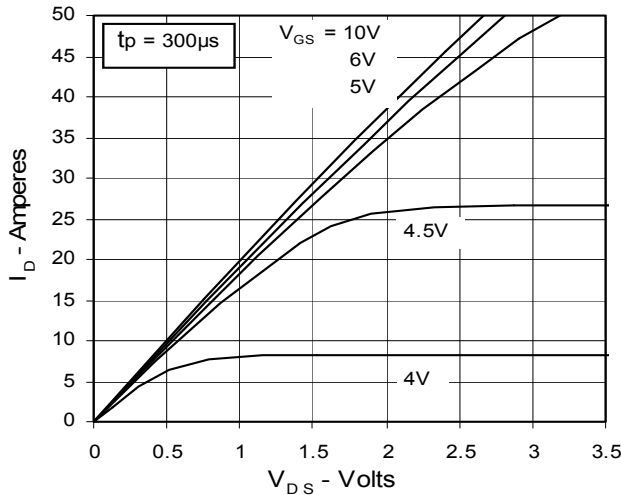

**Fig. 2. Extended Output Characteristics @ 25 deg. C**

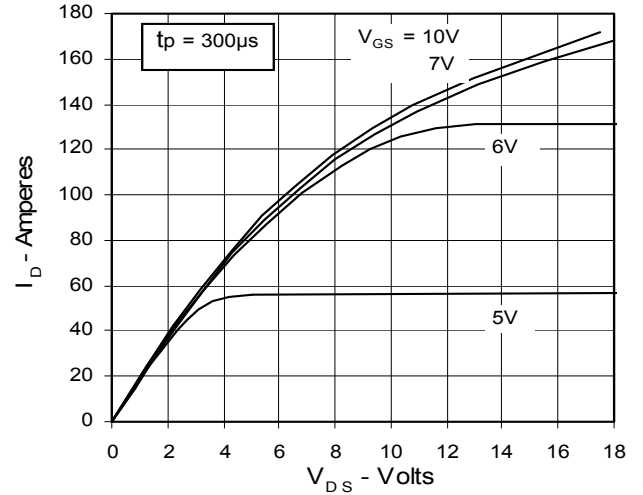

**Fig. 3. Output Characteristics @ 125 Deg. C**

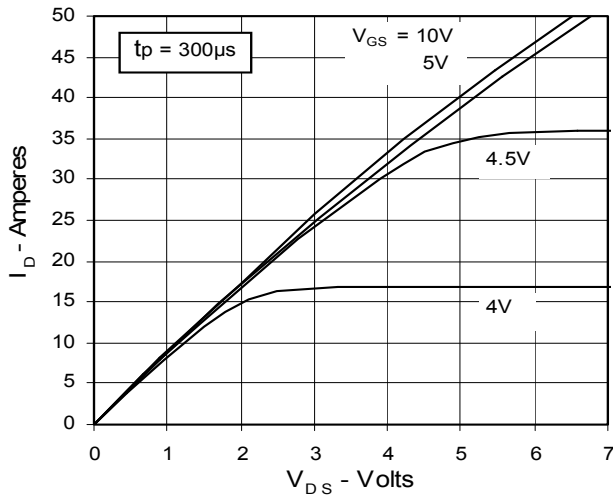

**Fig. 4.  $R_{DS(on)}$  Normalized to  $I_{D100}$  Value vs. Junction Temperature**

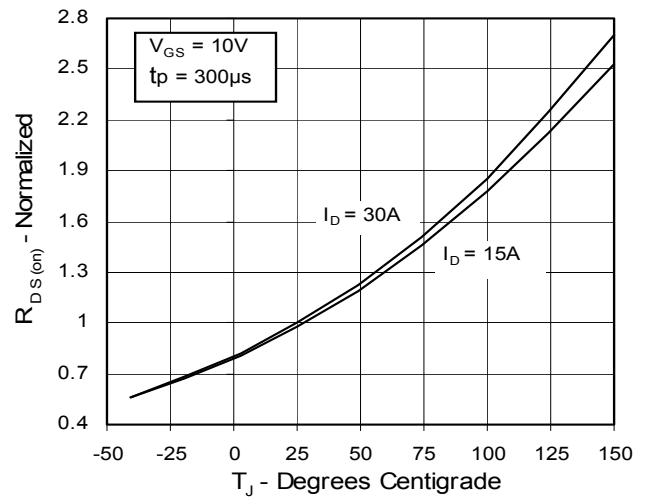

**Fig. 5.  $R_{DS(on)}$  Normalized to  $I_{D100}$  Value vs.  $I_D$**

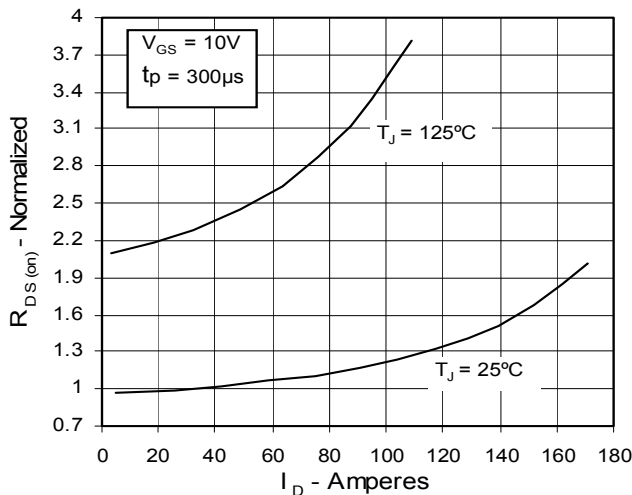

**Fig. 6. Drain Current vs. Case Temperature**

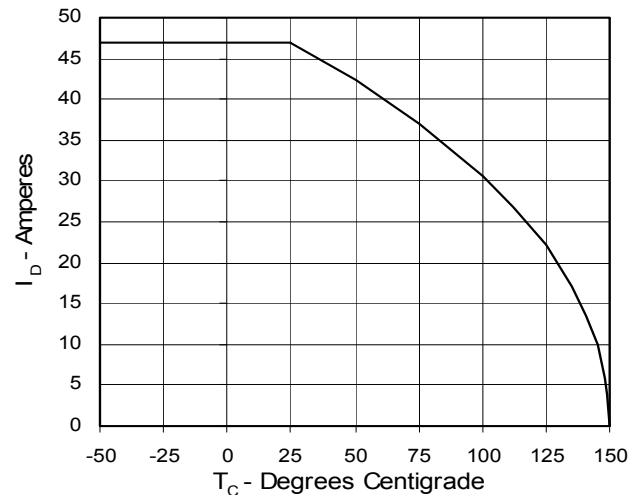

**Fig. 7. Input Admittance**

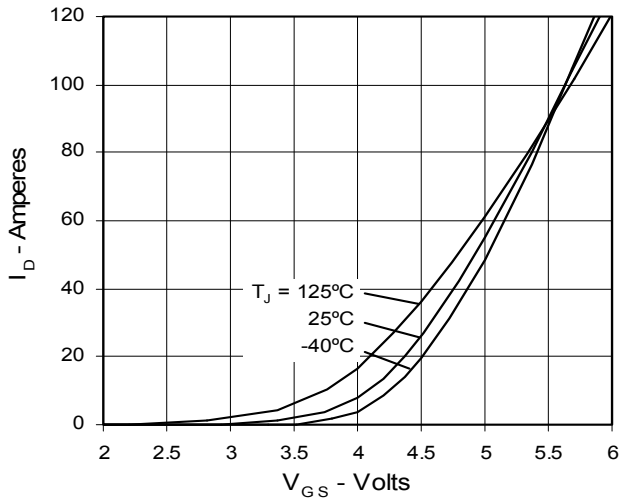

**Fig. 8. Transconductance**

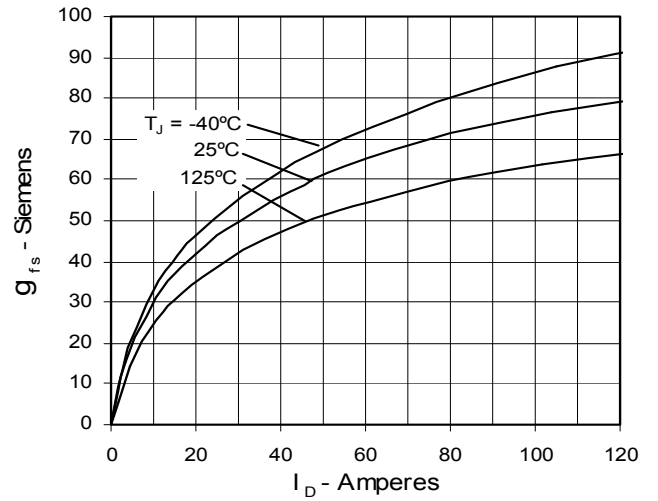

**Fig. 9. Source Current vs. Source-To-Drain Voltage**

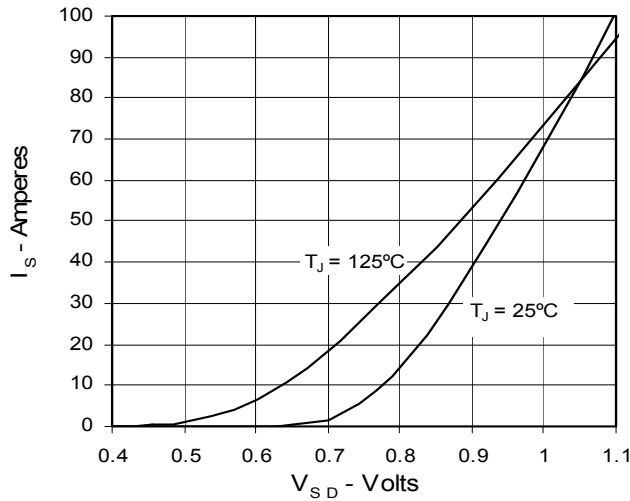

**Fig. 10. Gate Charge**

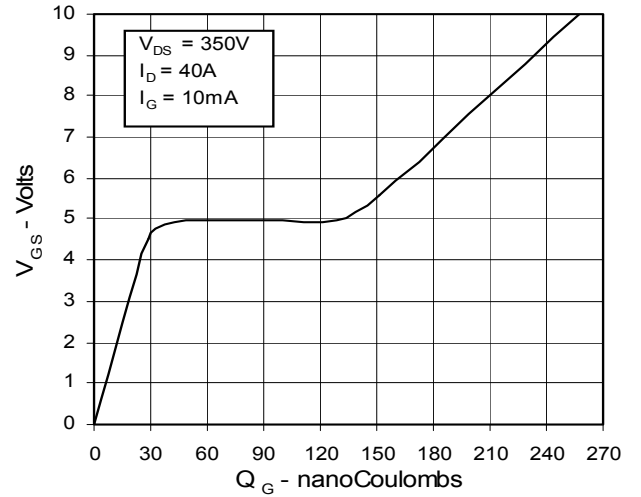

**Fig. 11. Capacitance**

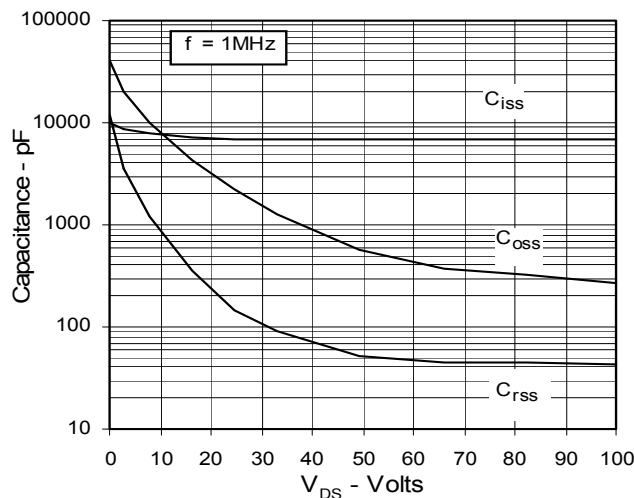

**Fig. 12. Maximum Transient Thermal Resistance**

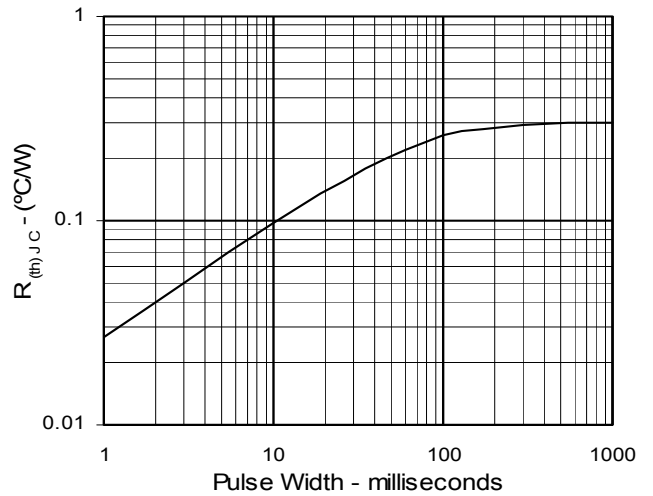



---

Disclaimer Notice - Information furnished is believed to be accurate and reliable. However, users should independently evaluate the suitability of and test each product selected for their own applications. Littelfuse products are not designed for, and may not be used in, all applications. Read complete Disclaimer Notice at [www.littelfuse.com/disclaimer-electronics](http://www.littelfuse.com/disclaimer-electronics).

## Looking for pricing, stock, or lifecycle information?

Click below to explore more details on WIN SOURCE:

- ⊖ [View IXKH47N60C on WIN SOURCE](#)
- ⊖ [IXYS Information](#)

## Optimize Your Supply Chain with WIN SOURCE Solutions

- ✓ Global Sourcing Solution
- ✓ Obsolete Management
- ✓ Cost Control Management
- ✓ Shortage Management
- ✓ Alternative Solution
- ✓ Excess Inventory Management