



**THE DATASHEET OF
AO3422**





General Description

The AO3422 uses advanced trench technology to provide excellent $R_{DS(ON)}$ and low gate charge. It offers operation over a wide gate drive range from 2.5V to 12V. This device is suitable for use as a load switch.

Features

- $V_{DS} (V) = 55V$
- $I_D = 2.1A (V_{GS} = 4.5V)$
- $R_{DS(ON)} < 160m\Omega (V_{GS} = 4.5V)$
- $R_{DS(ON)} < 200m\Omega (V_{GS} = 2.5V)$

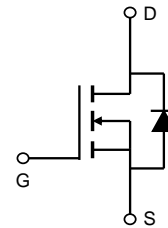
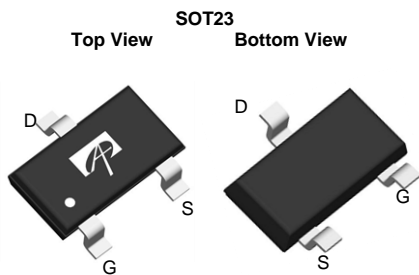

Absolute Maximum Ratings $T_A=25^\circ C$ unless otherwise noted

Parameter	Symbol	Maximum	Units
Drain-Source Voltage	V_{DS}	55	V
Gate-Source Voltage	V_{GS}	± 12	V
Continuous Drain Current ^A	I_D	$T_A=25^\circ C$	A
		$T_A=70^\circ C$	
Pulsed Drain Current ^B	I_{DM}	10	
Power Dissipation	P_D	$T_A=25^\circ C$	W
		$T_A=70^\circ C$	
Junction and Storage Temperature Range	T_J, T_{STG}	-55 to 150	$^\circ C$

Thermal Characteristics

Parameter	Symbol	Typ	Max	Units
Maximum Junction-to-Ambient ^A	$R_{\theta JA}$	75	100	$^\circ C/W$
Maximum Junction-to-Ambient ^A		Steady-State	115	
Maximum Junction-to-Lead ^C	$R_{\theta JL}$	48	60	$^\circ C/W$

Electrical Characteristics (T_J=25°C unless otherwise noted)

Symbol	Parameter	Conditions	Min	Typ	Max	Units	
STATIC PARAMETERS							
B _V DSS	Drain-Source Breakdown Voltage	I _D =10mA, V _{GS} =0V	55			V	
I _{DSS}	Zero Gate Voltage Drain Current	V _{DS} =44V, V _{GS} =0V T _J =55°C			1 5	μA	
I _{GSS}	Gate-Source leakage current	V _{DS} =0V, V _{GS} =±12V			±100	nA	
V _{GS(th)}	Gate Threshold Voltage	V _{DS} =V _{GS} I _D =250μA	0.6	1.3	2	V	
I _{D(ON)}	On state drain current	V _{GS} =4.5V, V _{DS} =5V	10			A	
R _{DS(ON)}	Static Drain-Source On-Resistance	V _{GS} =4.5V, I _D =2.1A T _J =125°C		125 175	160 210	mΩ	
		V _{GS} =2.5V, I _D =1.5A		157	200		mΩ
g _{FS}	Forward Transconductance	V _{DS} =5V, I _D =2.1A		11		S	
V _{SD}	Diode Forward Voltage	I _S =1A		0.78	1	V	
I _S	Maximum Body-Diode Continuous Current				1	A	
DYNAMIC PARAMETERS							
C _{iss}	Input Capacitance	V _{GS} =0V, V _{DS} =25V, f=1MHz		214	300	pF	
C _{oss}	Output Capacitance				31		pF
C _{rss}	Reverse Transfer Capacitance				12.6		pF
R _g	Gate resistance	V _{GS} =0V, V _{DS} =0V, f=1MHz		1.3	3	Ω	
SWITCHING PARAMETERS							
Q _g	Total Gate Charge	V _{GS} =4.5V, V _{DS} =27.5V, I _D =2.1A		2.6	3.3	nC	
Q _{gs}	Gate Source Charge			0.6		nC	
Q _{gd}	Gate Drain Charge			0.8		nC	
t _{D(on)}	Turn-On DelayTime	V _{GS} =10V, V _{DS} =27.5V, R _L =12Ω, R _{GEN} =3Ω		2.3		ns	
t _r	Turn-On Rise Time			2.4		ns	
t _{D(off)}	Turn-Off DelayTime			16.5		ns	
t _f	Turn-Off Fall Time			2		ns	
t _{rr}	Body Diode Reverse Recovery Time	I _F =2.1A, dI/dt=100A/μs		20	30	ns	
Q _{rr}	Body Diode Reverse Recovery Charge	I _F =2.1A, dI/dt=100A/μs		17		nC	

A: The value of R_{θJA} is measured with the device mounted on 1 in² FR-4 board with 2oz. Copper, in a still air environment with T_A=25° C. The value in any given application depends on the user's specific board design. The current rating is based on the t ≤ 10s thermal resistance rating.

B: Repetitive rating, pulse width limited by junction temperature.

C: The R_{θJA} is the sum of the thermal impedance from junction to lead R_{θJL} and lead to ambient.

D: The static characteristics in Figures 1 to 6 are obtained using <300 μs pulses, duty cycle 0.5% max.

E: These tests are performed with the device mounted on 1 in² FR-4 board with 2oz. Copper, in a still air environment with T_A=25° C. The SOA curve provides a single pulse rating.

Rev2: Sep 2010

APPLICATIONS OR USES AS CRITICAL COMPONENTS IN LIFE SUPPORT DEVICES OR SYSTEMS ARE NOT AUTHORIZED. AOS DOES NOT ASSUME ANY LIABILITY ARISING OUT OF SUCH APPLICATIONS OR USES OF ITS PRODUCTS. AOS RESERVES THE RIGHT TO MAKE CHANGES TO PRODUCT SPECIFICATIONS WITHOUT NOTICE. IT IS THE RESPONSIBILITY OF THE CUSTOMER TO EVALUATE SUITABILITY OF THE PRODUCT FOR THEIR INTENDED APPLICATION. CUSTOMER SHALL COMPLY WITH APPLICABLE LEGAL REQUIREMENTS, INCLUDING ALL APPLICABLE EXPORT CONTROL RULES, REGULATIONS AND LIMITATIONS.

AOS' products are provided subject to AOS' terms and conditions of sale which are set forth at:

http://www.aosmd.com/terms_and_conditions_of_sale

TYPICAL ELECTRICAL AND THERMAL CHARACTERISTICS

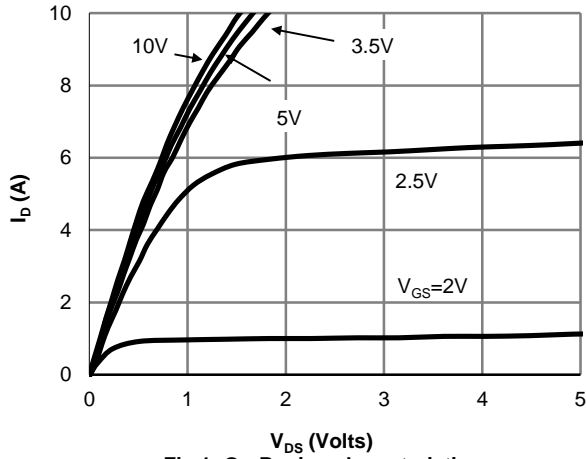

Fig 1: On-Region characteristics

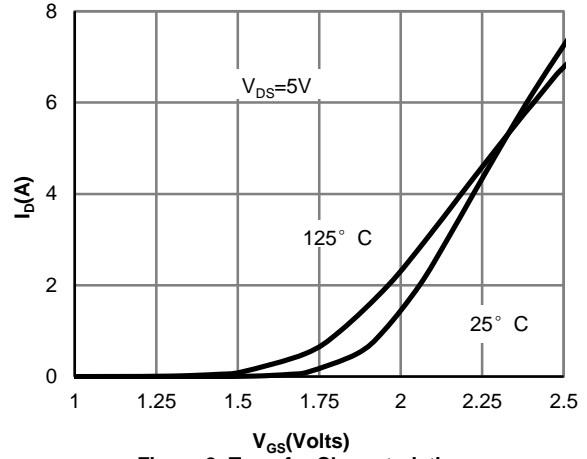

Figure 2: Transfer Characteristics

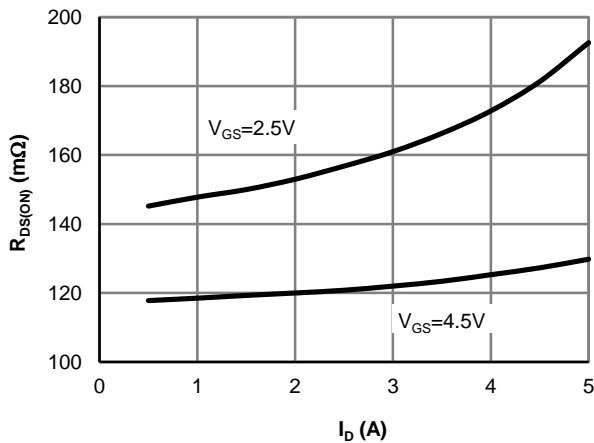

Figure 3: On-Resistance vs. Drain Current and Gate Voltage

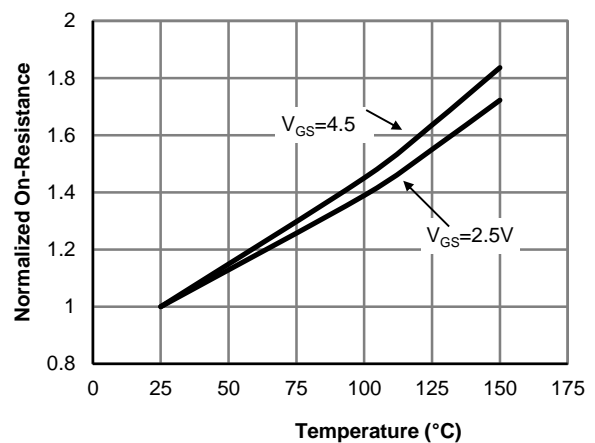

Figure 4: On-Resistance vs. Junction Temperature

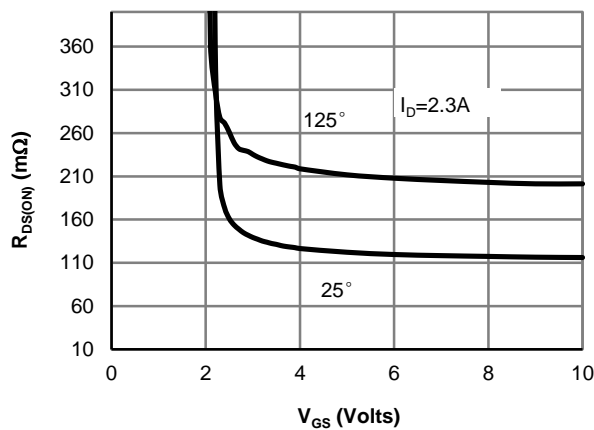

Figure 5: On-Resistance vs. Gate-Source Voltage

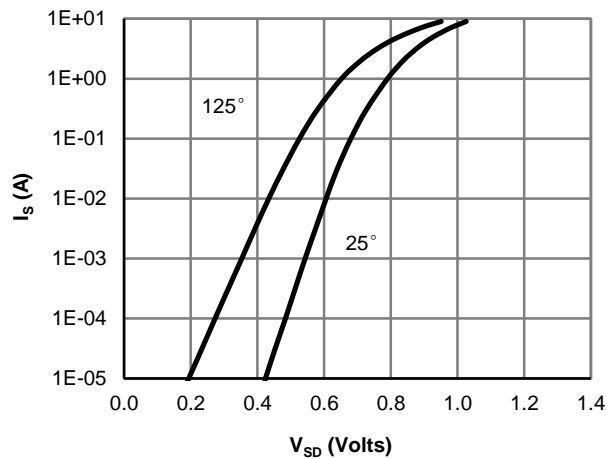

Figure 6: Body-Diode Characteristics

TYPICAL ELECTRICAL AND THERMAL CHARACTERISTICS

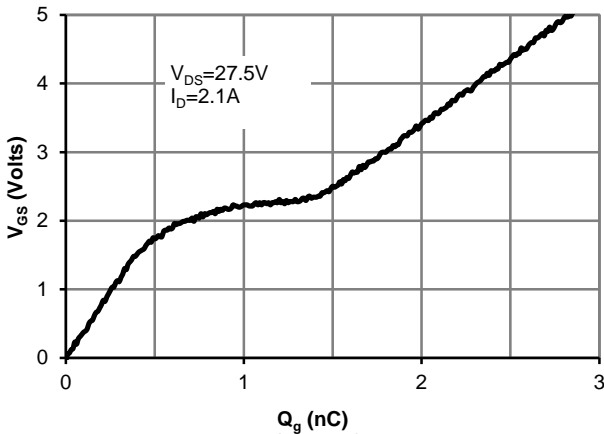

Figure 7: Gate-Charge Characteristics

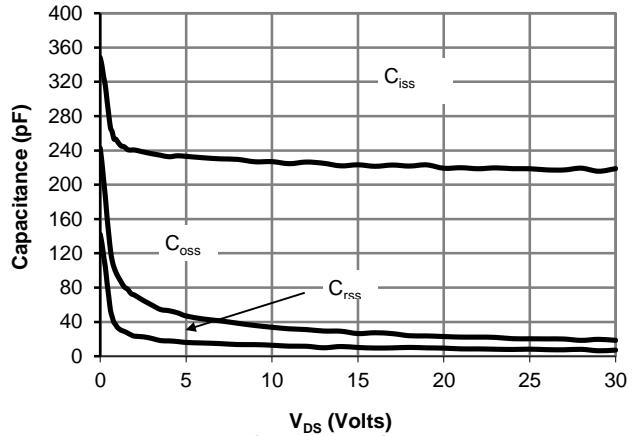

Figure 8: Capacitance Characteristics

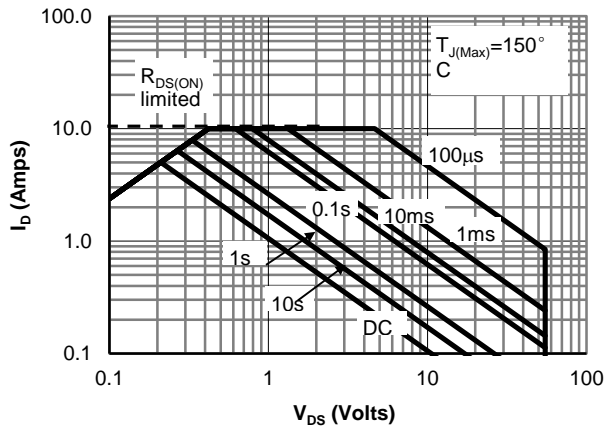

Figure 9: Maximum Forward Biased Safe Operating Area (Note E)

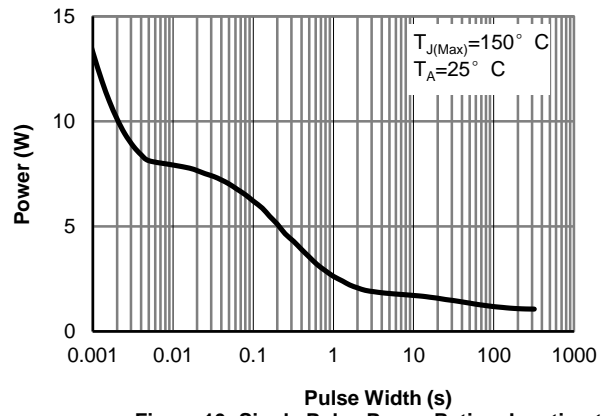

Figure 10: Single Pulse Power Rating Junction-to-Ambient (Note E)

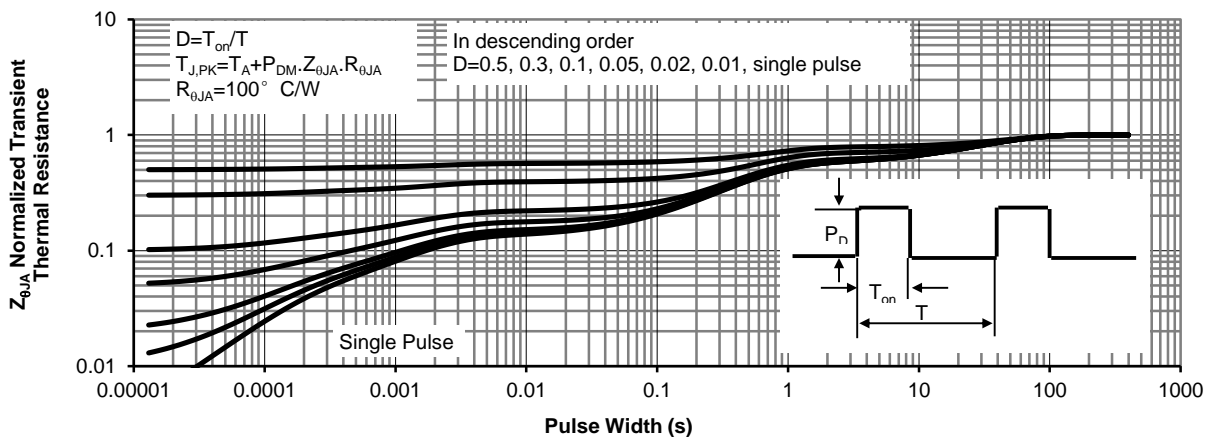
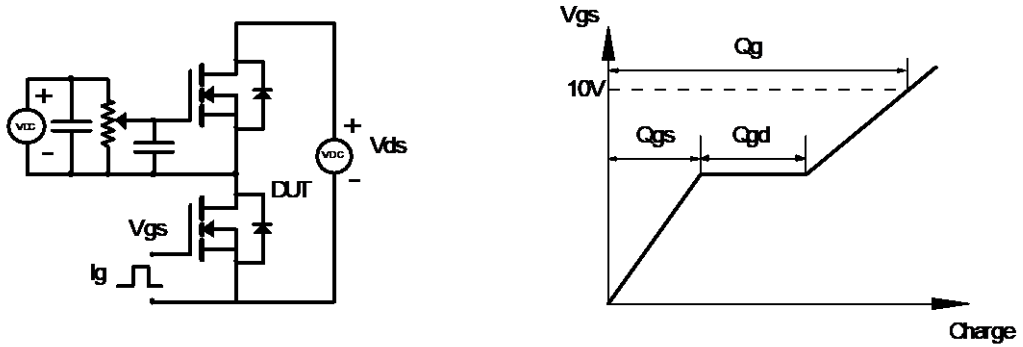
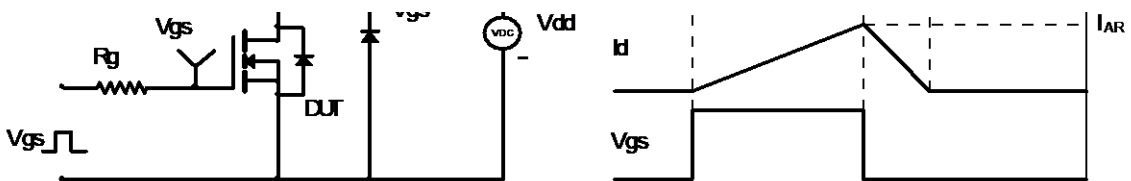
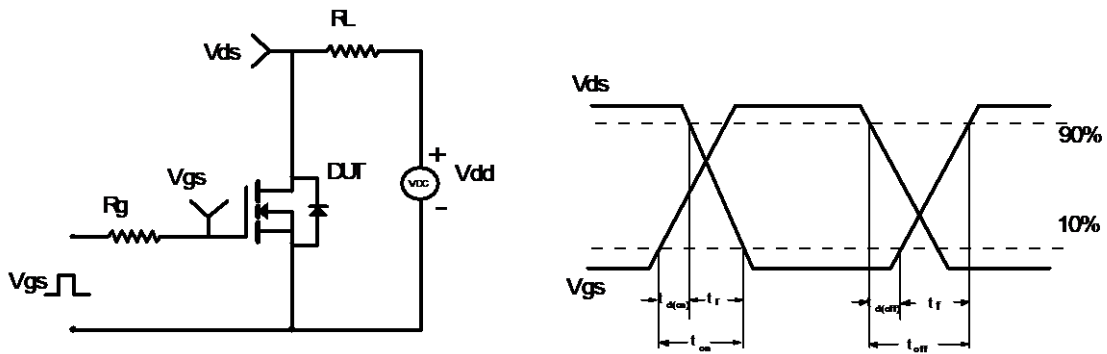

Figure 11: Normalized Maximum Transient Thermal Impedance

Gate Charge Test Circuit & Waveform



Resistive Switching Test Circuit & Waveforms



Diode Recovery Test Circuit & Waveforms

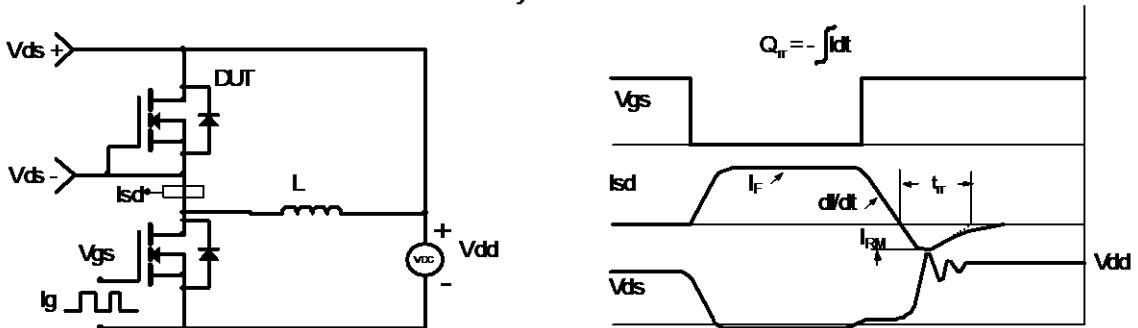

Looking for pricing, stock, or lifecycle information?

Click below to explore more details on WIN SOURCE:

- [View AO3422 on WIN SOURCE](#)
- [Alpha & Omega Semiconductor Inc. Information](#)

Optimize Your Supply Chain with WIN SOURCE Solutions

- ✓ Global Sourcing Solution
- ✓ Obsolete Management
- ✓ Cost Control Management
- ✓ Shortage Management
- ✓ Alternative Solution
- ✓ Excess Inventory Management