



**THE DATASHEET OF
SC431AVSNT1G**



NCP431A, SC431A, NCP431B, SC431B, NCP432B, SC432B Series



ON Semiconductor®

www.onsemi.com

Programmable Precision References

The NCP431/NCP432 integrated circuits are three-terminal programmable shunt regulator diodes. These monolithic IC voltage references operate as a low temperature coefficient zener which is programmable from V_{ref} to 36 V using two external resistors. These devices exhibit a wide operating current range of 40 μ A to 100 mA with a typical dynamic impedance of 0.22 Ω . The characteristics of these references make them excellent replacements for zener diodes in many applications such as digital voltmeters, power supplies, and op amp circuitry. The 2.5 V reference makes it convenient to obtain a stable reference from 5.0 V logic supplies, and since the NCP431/NCP432 operates as a shunt regulator, it can be used as either a positive or negative voltage reference. Low minimum operating current makes this device an ideal choice for secondary regulators in SMPS adapters with extremely low no-load consumption.

Features

- Programmable Output Voltage to 36 V
- Low Minimum Operating Current: 40 μ A, Typ @ 25°C
- Voltage Reference Tolerance: $\pm 0.5\%$, Typ @ 25°C (NCP431B/NCP432B)
- Low Dynamic Output Impedance, 0.22 Ω Typical
- Sink Current Capability of 40 μ A to 100 mA
- Equivalent Full-Range Temperature Coefficient of 50 ppm/°C Typical
- Temperature Compensated for Operation over Full Rated Operating Temperature Range
- SC Prefix for Automotive and Other Applications Requiring Unique Site and Control Change Requirements; AEC-Q100 Qualified and PPAP Capable
- These are Pb-Free Devices

Typical Applications

- Voltage Adapters
- Switching Power Supply
- Precision Voltage Reference
- Charger
- Instrumentation

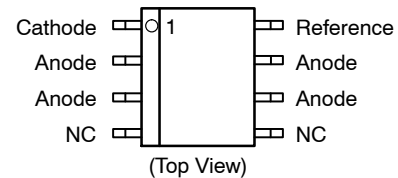
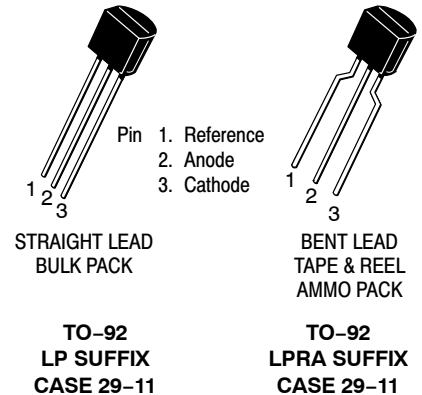

NCP431/SC431
Pin 1. Reference
2. Cathode
3. Anode

NCP432/SC432
Pin 1. Cathode
2. Reference
3. Anode

ORDERING AND MARKING INFORMATION

See detailed ordering and shipping information in the package dimensions section on page 14 of this data sheet.

NCP431A, SC431A, NCP431B, SC431B, NCP432B, SC432B Series

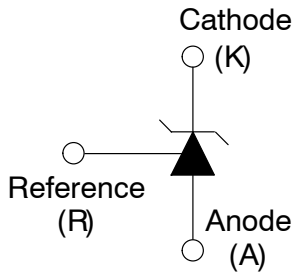

Figure 1. Symbol

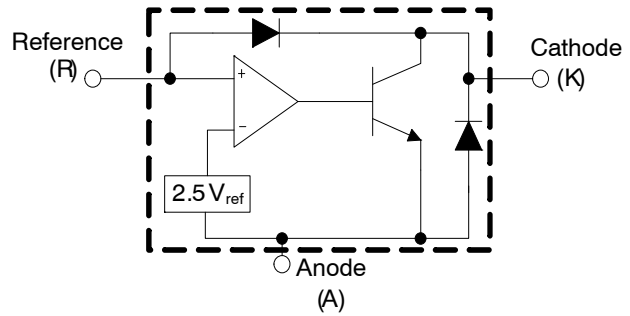

Figure 2. Representative Block diagram

This device contains 20 active transistors

MAXIMUM RATINGS (Full operating ambient temperature range applies, unless otherwise noted)

Symbol	Rating	Value	Unit
V_{KA}	Cathode to Anode Voltage	37	V
I_K	Cathode Current Range, Continuous	-100 to +150	mA
I_{ref}	Reference Input Current Range, Continuous	-5 to +10	mA
T_J	Operating Junction Temperature	150	°C
T_A	Operating Ambient Temperature Range	-40 to +125	°C
T_{stg}	Storage Temperature Range	-65 to +150	°C
P_D	Total Power Dissipation @ $T_A = 25^\circ\text{C}$ Derate above 25°C Ambient Temperature D, LP Suffix Plastic Package SN1 Suffix Plastic Package	0.70 0.52	W
P_D	Total Power Dissipation @ $T_C = 25^\circ\text{C}$ Derate above 25°C Case Temperature D, LP Suffix Plastic Package	1.5	W
HBM CDM	ESD Rating (Note 1) Human Body Model per JEDEC JESD22-A114F Charged Device Model per JEDEC JESD22-C101E	>2000 >1000	V

Stresses exceeding those listed in the Maximum Ratings table may damage the device. If any of these limits are exceeded, device functionality should not be assumed, damage may occur and reliability may be affected.

1. This device contains latch-up protection and exceeds ± 100 mA per JEDEC standard JESD78.

RECOMMENDED OPERATING CONDITIONS

Symbol	Condition	Min	Max	Unit
V_{KA}	Cathode to Anode Voltage	V_{ref}	36	V
I_K	Cathode Current	0.04	100	mA

Functional operation above the stresses listed in the Recommended Operating Ranges is not implied. Extended exposure to stresses beyond the Recommended Operating Ranges limits may affect device reliability.

THERMAL CHARACTERISTICS

Symbol	Characteristic	LP Suffix Package (50 mm ² x 35 μm Cu)	D Suffix Package (50 mm ² x 35 μm Cu)	SN Suffix Package (10 mm ² x 35 μm Cu)	Unit
$R_{\theta JA}$	Thermal Resistance, Junction-to-Ambient	176	210	255	°C/W
$R_{\theta JL}$	Thermal Resistance, Junction-to-Lead (Lead 3)	75	68	80	°C/W

NCP431A, SC431A, NCP431B, SC431B, NCP432B, SC432B Series

ELECTRICAL CHARACTERISTICS (T_A = 25°C, unless otherwise noted.)

Symbol	Characteristic	NCP431AC			NCP431AI			NCP431AV/ SC431AV			Unit
		Min	Typ	Max	Min	Typ	Max	Min	Typ	Max	
V _{ref}	Reference Input Voltage V _{KA} = V _{ref} , I _K = 1 mA T _A = 25°C T _A = T _{low} to T _{high} (Figure 3, Note 2)	2.475 2.475	2.500 2.500	2.525 2.525	2.475 2.465	2.500 2.500	2.525 2.525	2.475 2.460	2.500 2.500	2.525 2.525	V
ΔV _{refT}	Reference Input Voltage Deviation Over Temperature Range (Figure 3, Notes 3, 4) V _{KA} = V _{ref} , I _K = 1 mA	-	-	-	-	5.0	10	-	10	15	mV
$\frac{\Delta V_{ref}}{\Delta V_{KA}}$	Ratio of Change in Reference Input Voltage to Change in Cathode to Anode Voltage I _K = 1 mA (Figure 4), ΔV _{KA} = 10 V to V _{ref} ΔV _{KA} = 36 V to 10 V	-	-1.85 -0.80	-3.1 -1.8	-	-1.85 -0.80	-3.1 -1.8	-	-1.85 -0.80	-3.1 -1.8	mV/ V
I _{ref}	Reference Input Current (Figure 4) I _K = 1 mA, R1 = 220 k, R2 = ∞ T _A = -40°C to +125°C	-	81	190	-	81	190	-	81	190	nA
ΔI _{refT}	Reference Input Current Deviation Over Temperature Range (Figure 4, Note 3) I _K = 1 mA, R1 = 10 k, R2 = ∞	-	22	55	-	22	55	-	22	55	nA
I _{min}	Minimum Cathode Current For Regulation V _{KA} = V _{ref} (Figure 3)	-	40	60	-	40	60	-	40	60	μA
I _{off}	Off-State Cathode Current (Figure 5) V _{KA} = 36 V, V _{ref} = 0 V	-	180	1000	-	180	1000	-	180	1000	nA
Z _{KA}	Dynamic Impedance (Figure 3, Note 5) V _{KA} = V _{ref} , ΔI _K = 1.0 mA to 100 mA f ≤ 1.0 kHz	-	0.22	0.5	-	0.22	0.5	-	0.22	0.5	Ω

Product parametric performance is indicated in the Electrical Characteristics for the listed test conditions, unless otherwise noted. Product performance may not be indicated by the Electrical Characteristics if operated under different conditions.

- T_{low} = -40°C for NCP431AI, NCP431AV, SC431AV
= 0°C for NCP431AC
T_{high} = 70°C for NCP431AC
= 85°C for NCP431AI
= 125°C for NCP431AV, SC431AV

3. Guaranteed by design

- The deviation parameter ΔV_{refT} is defined as the difference between the maximum and minimum values obtained over the full operating ambient temperature range that applies.

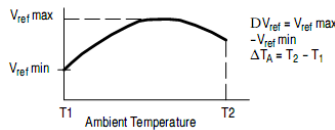

The average temperature coefficient of the reference input voltage, V_{ref} is defined as:

$$V_{ref} \frac{\text{ppm}}{^{\circ}\text{C}} = \frac{\left(\frac{\Delta V_{ref}}{V_{ref@25^{\circ}\text{C}}} \right) \times 10^6}{\Delta T_A} = \frac{\Delta V_{ref} \times 10^6}{\Delta T_A (V_{ref@25^{\circ}\text{C}})}$$

αV_{ref} can be positive or negative depending on whether V_{ref} Min or V_{ref} Max occurs at the lower ambient temperature.

Example: ΔV_{refT} = 17 mV and slope is positive
V_{ref} = 2.5 V, ΔT_A = 165°C (from -40°C to +125°C)

$$\alpha V_{ref} = \frac{0.017 \cdot 10^6}{165 \cdot 2.5} = 41.2 \text{ ppm}/^{\circ}\text{C}$$

- The dynamic impedance Z_{KA} is defined as: (|Z_{KA}| = (ΔV_{KA}/ΔI_K)). When the device is programmed with two external resistors, R1 and R2, the total dynamic impedance of the circuit is defined as: |Z_{KA}| ≈ |Z_{KA}| (1 + (R1/R2)).
- SC431AVSNT1G - T_{low} = -40°C, T_{high} = 125°C. Guaranteed by design. SC Prefix for Automotive and Other Applications Requiring Unique Site and Control Change Requirements; AEC-Q100 Qualified and PPAP Capable.

NCP431A, SC431A, NCP431B, SC431B, NCP432B, SC432B Series

ELECTRICAL CHARACTERISTICS (T_A = 25°C, unless otherwise noted.)

Symbol	Characteristic	NCP431BC NCP432BC			NCP431BI NCP432BI			NCP/SC431BV NCP/SC432BV			Unit
		Min	Typ	Max	Min	Typ	Max	Min	Typ	Max	
V _{ref}	Reference Input Voltage V _{KA} = V _{ref} , I _K = 1 mA T _A = 25°C T _A = T _{low} to T _{high} (Figure 3, Note 7)	2.4875 2.4875	2.500 2.500	2.5125 2.5125	2.4875 2.4775	2.500 2.500	2.5125 2.5125	2.4875 2.4725	2.500 2.500	2.5125 2.5125	V
ΔV _{refT}	Reference Input Voltage Deviation Over Temperature Range (Figure 3, Notes 8, 9) V _{KA} = V _{ref} , I _K = 1 mA	-	-	-	-	5.0	10	-	10	15	mV
$\frac{\Delta V_{ref}}{\Delta V_{KA}}$	Ratio of Change in Reference Input Voltage to Change in Cathode to Anode Voltage I _K = 1 mA (Figure 4), ΔV _{KA} = 10 V to V _{ref} ΔV _{KA} = 36 V to 10 V	-	-1.85 -0.80	-3.1 -1.8	-	-1.85 -0.80	-3.1 -1.8	-	-1.85 -0.80	-3.1 -1.8	mV/V
I _{ref}	Reference Input Current (Figure 4) I _K = 1 mA, R1 = 220 k, R2 = ∞ T _A = -40°C to +125°C	-	81	190	-	81	190	-	81	190	nA
ΔI _{refT}	Reference Input Current Deviation Over Temperature Range (Figure 4, Note 8) I _K = 1 mA, R1 = 10 k, R2 = ∞	-	22	55	-	22	55	-	22	55	nA
I _{min}	Minimum Cathode Current For Regulation V _{KA} = V _{ref} (Figure 3)	-	40	60	-	40	60	-	40	60	μA
I _{off}	Off-State Cathode Current (Figure 5) V _{KA} = 36 V, V _{ref} = 0 V	-	180	1000	-	180	1000	-	180	1000	nA
Z _{KA}	Dynamic Impedance (Figure 3, Note 10) V _{KA} = V _{ref} , ΔI _K = 1.0 mA to 100 mA f ≤ 1.0 kHz	-	0.22	0.5	-	0.22	0.5	-	0.22	0.5	Ω

Product parametric performance is indicated in the Electrical Characteristics for the listed test conditions, unless otherwise noted. Product performance may not be indicated by the Electrical Characteristics if operated under different conditions.

- T_{low} = -40°C for NCP431BI, NCP431BV, NCP432BI, NCP432BV, SC431B, SC432B
= 0°C for NCP431BC, NCP432BC
T_{high} = 70°C for NCP431BC, NCP432BC
= 85°C for NCP431BI, NCP432BI
= 125°C for NCP431BV, NCP432BV, SC431BV, SC432BV

8. Guaranteed by design

9. The deviation parameter ΔV_{refT} is defined as the difference between the maximum and minimum values obtained over the full operating ambient temperature range that applies.

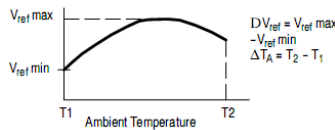

The average temperature coefficient of the reference input voltage, Vref is defined as:

$$V_{ref} \frac{\text{ppm}}{^{\circ}\text{C}} = \frac{\left(\frac{\Delta V_{ref}}{V_{ref@25^{\circ}\text{C}}} \right) \times 10^6}{\Delta T_A} = \frac{\Delta V_{ref} \times 10^6}{\Delta T_A (V_{ref@25^{\circ}\text{C}})}$$

αVref can be positive or negative depending on whether Vref Min or Vref Max occurs at the lower ambient temperature.

Example: ΔV_{refT} = 17 mV and slope is positive
V_{ref} = 2.5 V, ΔT_A = 165°C (from -40°C to +125°C)

$$\alpha V_{ref} = \frac{0.017 \cdot 10^6}{165 \cdot 2.5} = 41.2 \text{ ppm}/^{\circ}\text{C}$$

10. The dynamic impedance Z_{KA} is defined as: (|Z_{KA}| = (ΔV_{KA}/ΔI_K)). When the device is programmed with two external resistors, R1 and R2, the total dynamic impedance of the circuit is defined as: |Z_{KA}'| ≈ |Z_{KA}| (1 + (R1/R2))

11. SC431BVSNT1G, SC432BVSNT1G - T_{low} = -40°C, T_{high} = 125°C. Guaranteed by design. SC Prefix for Automotive and Other Applications Requiring Unique Site and Control Change Requirements; AEC-Q100 Qualified and PPAP Capable.

NCP431A, SC431A, NCP431B, SC431B, NCP432B, SC432B Series

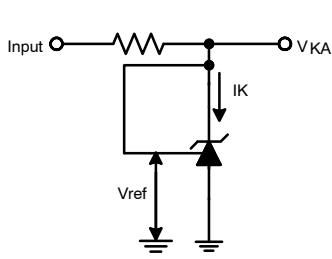

Figure 3. Test Circuit for $V_{KA} = V_{ref}$

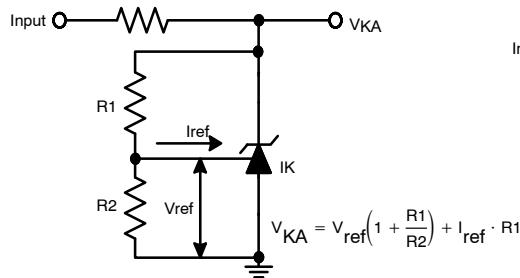

Figure 4. Test Circuit for $V_{KA} > V_{ref}$

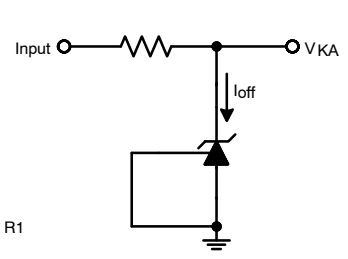

Figure 5. Test Circuit for I_{off}

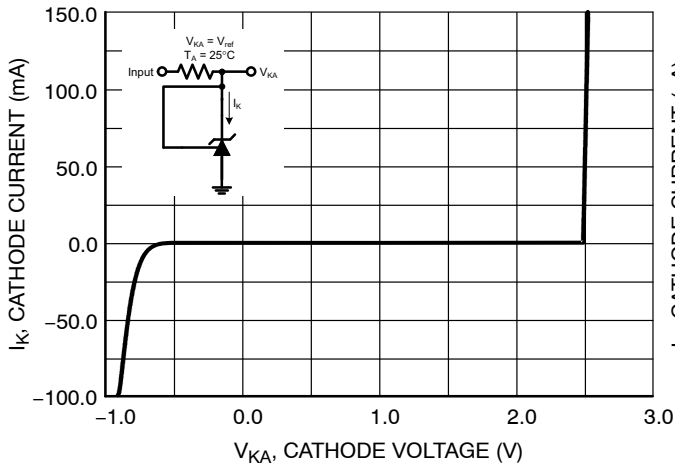

Figure 6. Cathode Current versus Cathode Voltage

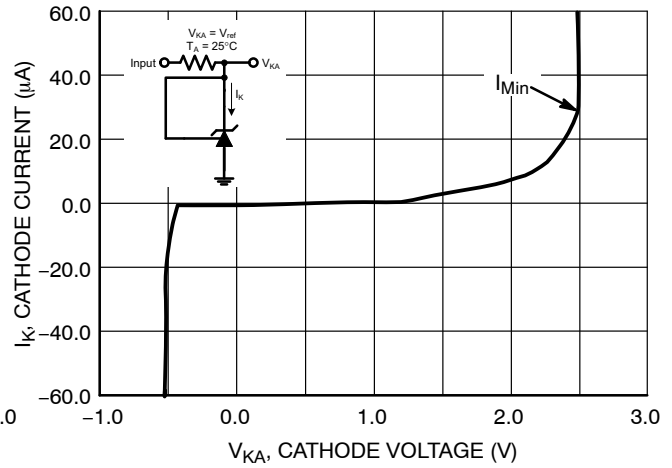

Figure 7. Cathode Current versus Cathode Voltage

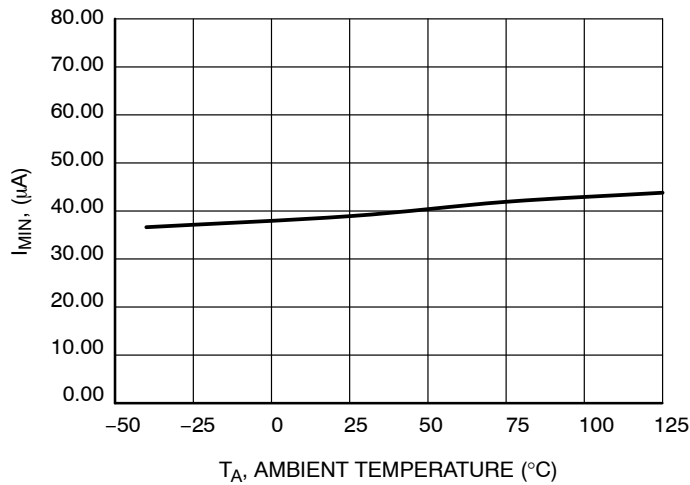

Figure 8. Minimum Cathode Current Regulation versus Ambient Temperature

NCP431A, SC431A, NCP431B, SC431B, NCP432B, SC432B Series

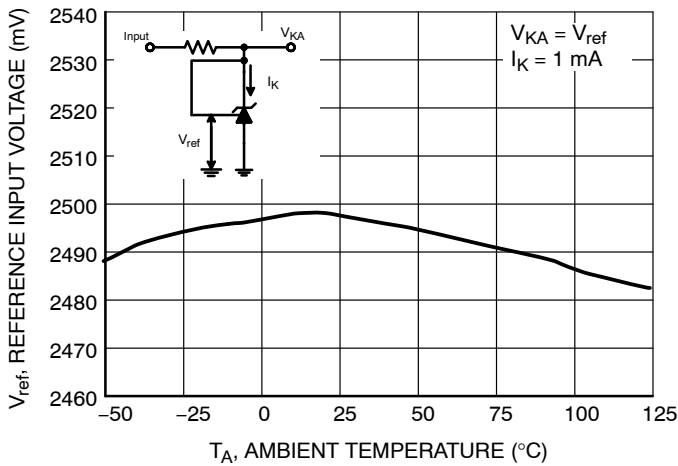

Figure 9. Reference Input Voltage versus Ambient temperature

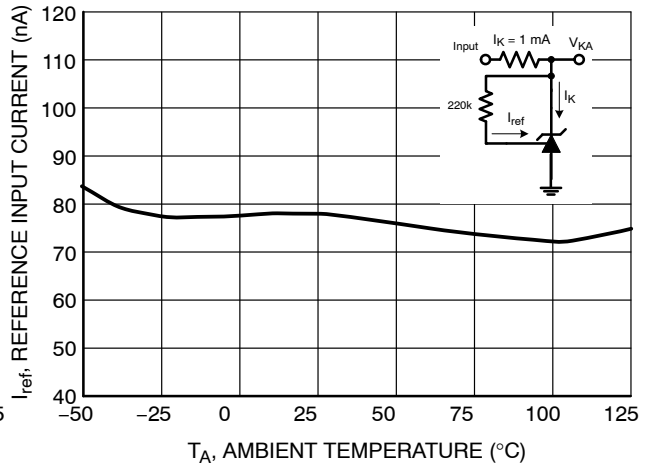

Figure 10. Reference Input Current versus Ambient temperature

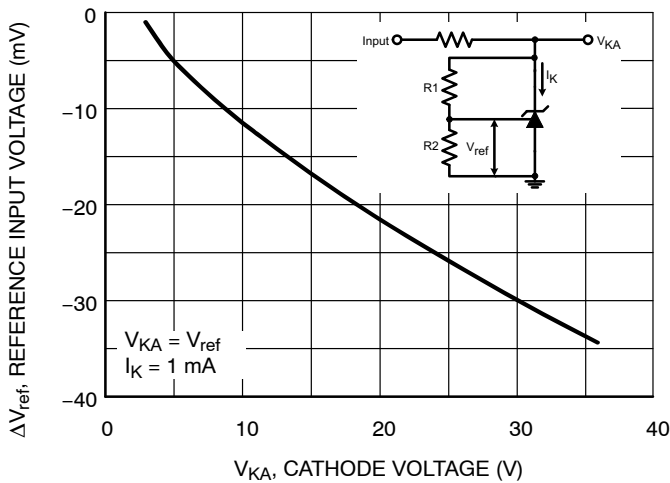

Figure 11. Change in Reference Input Voltage versus Cathode Voltage

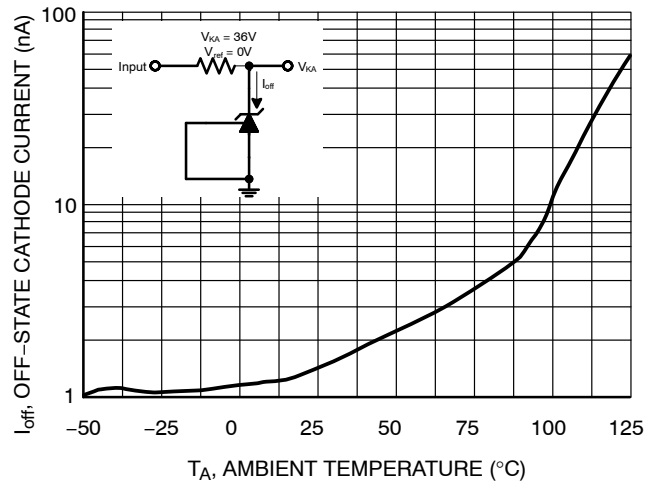

Figure 12. Off-State Cathode Current versus Ambient Temperature

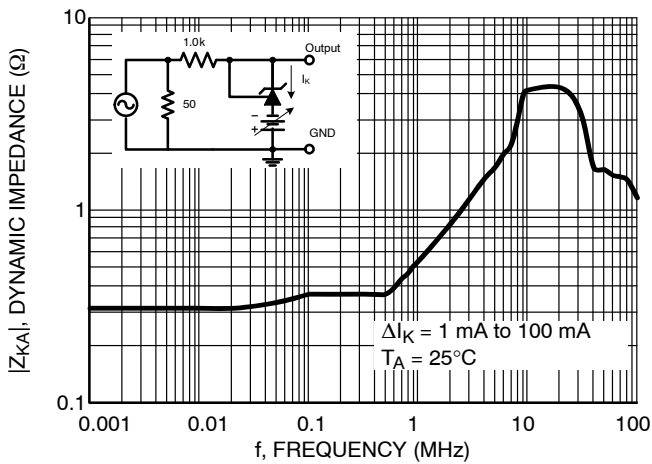

Figure 13. Dynamic Impedance versus Frequency

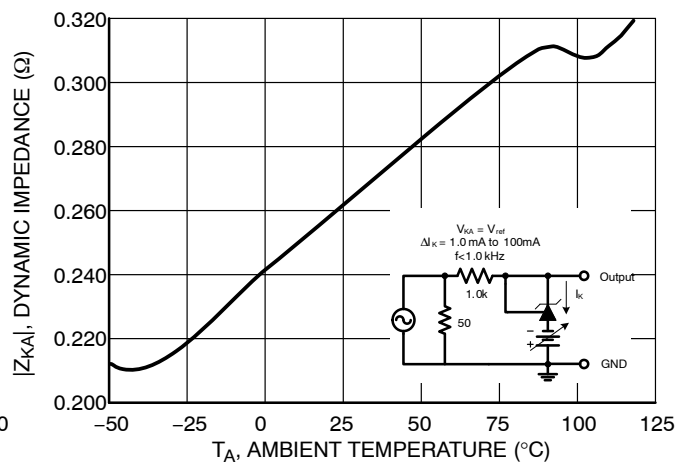

Figure 14. Dynamic Impedance versus Ambient Temperature

NCP431A, SC431A, NCP431B, SC431B, NCP432B, SC432B Series

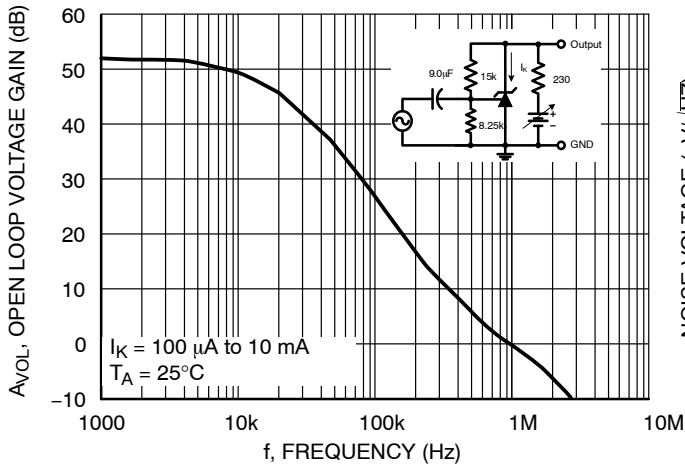

Figure 15. Open-Loop Voltage Gain versus Frequency

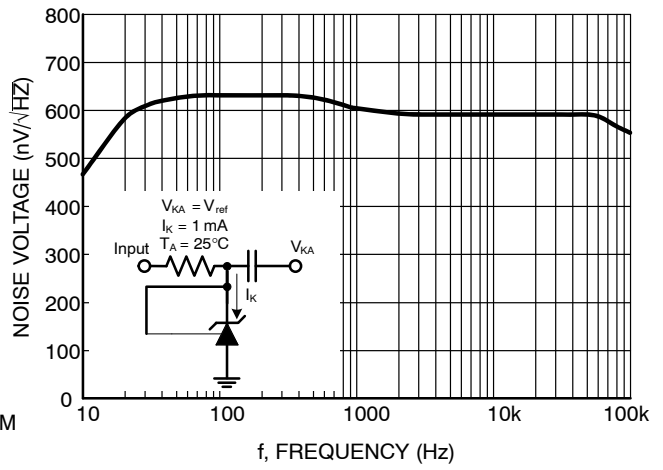

Figure 16. Spectral Noise Density

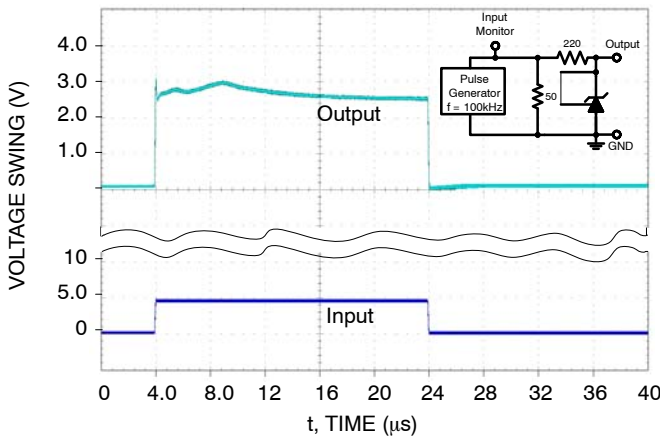

Figure 17. Pulse Response

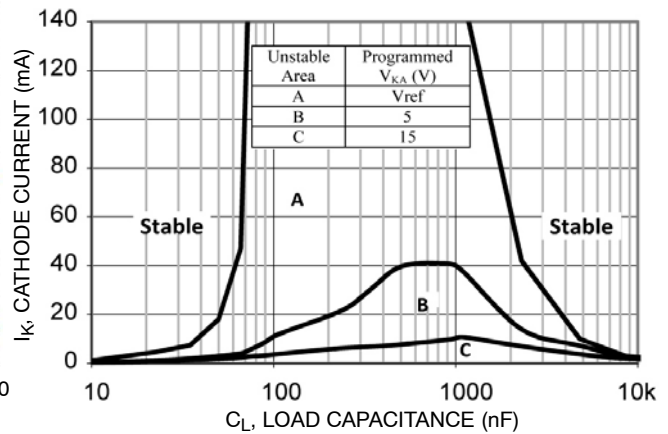

Figure 18. Stability Boundary Conditions

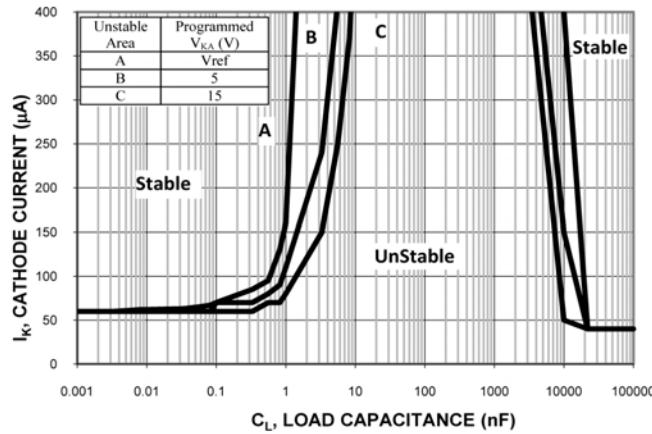

Figure 19. Stability Boundary Conditions for Small Cathode Current

NCP431A, SC431A, NCP431B, SC431B, NCP432B, SC432B Series

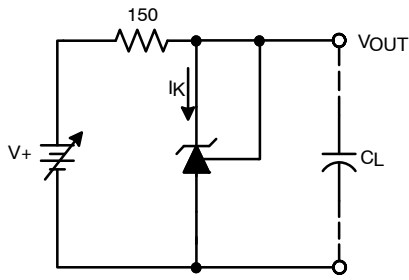

Figure 20. Test Circuit For Curve A of Stability Boundary Conditions

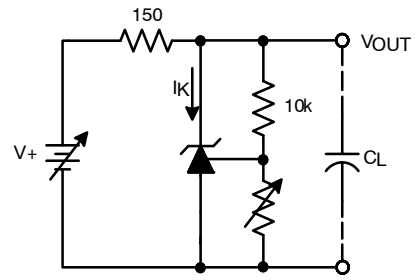
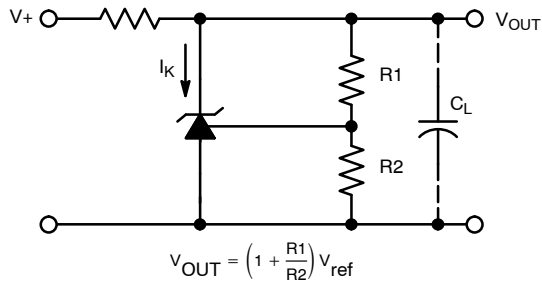

Figure 21. Test Circuit For Curve B And C of Stability Boundary Conditions

TYPICAL APPLICATIONS



$$V_{OUT} = \left(1 + \frac{R1}{R2}\right) V_{ref}$$

Figure 22. Shunt Regulator

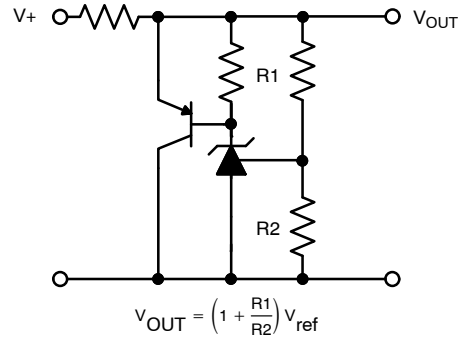

$$V_{OUT} = \left(1 + \frac{R1}{R2}\right) V_{ref}$$

Figure 23. High Current Shunt Regulator

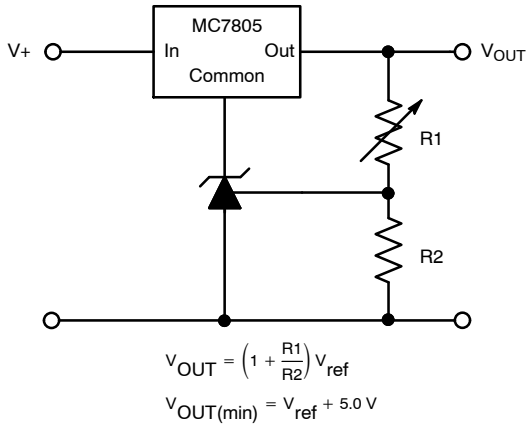

$$V_{OUT} = \left(1 + \frac{R1}{R2}\right) V_{ref}$$

$$V_{OUT(min)} = V_{ref} + 5.0\text{ V}$$

Figure 24. Output Control for a Tree-Terminal Fixed Regulator

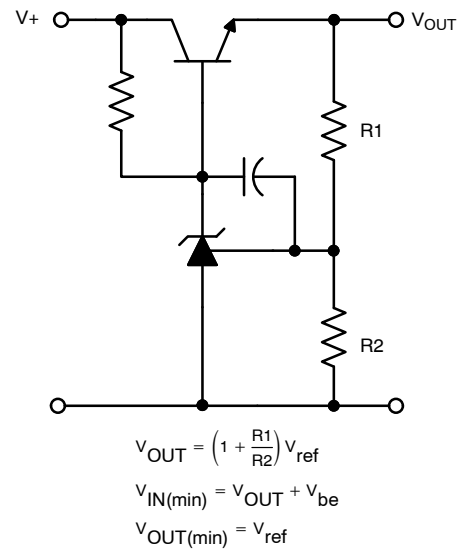

$$V_{OUT} = \left(1 + \frac{R1}{R2}\right) V_{ref}$$

$$V_{IN(min)} = V_{OUT} + V_{be}$$

$$V_{OUT(min)} = V_{ref}$$

Figure 25. Series Pass Regulator

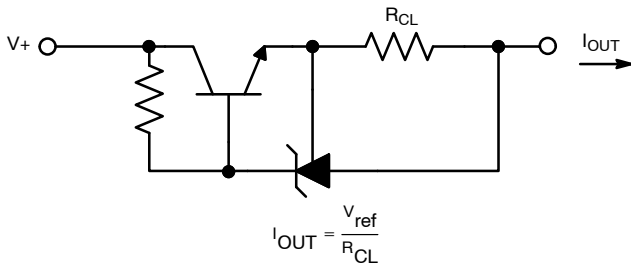

$$I_{OUT} = \frac{V_{ref}}{R_{CL}}$$

Figure 26. Constant Current Source

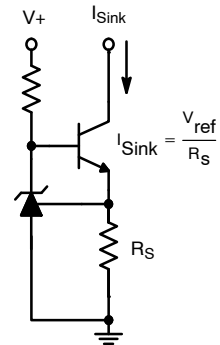

$$I_{Sink} = \frac{V_{ref}}{R_S}$$

Figure 27. Constant Current Sink

NCP431A, SC431A, NCP431B, SC431B, NCP432B, SC432B Series

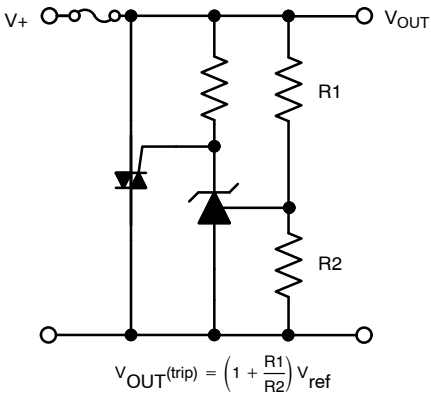

Figure 28. Triac Crowbar

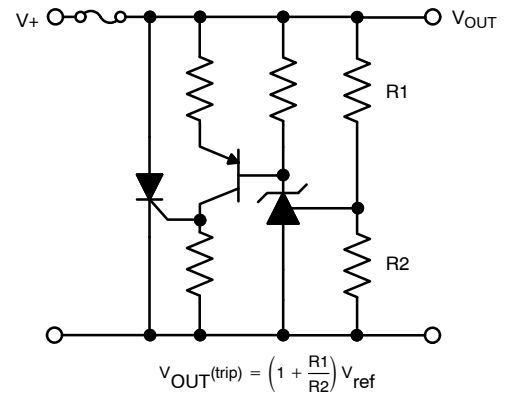
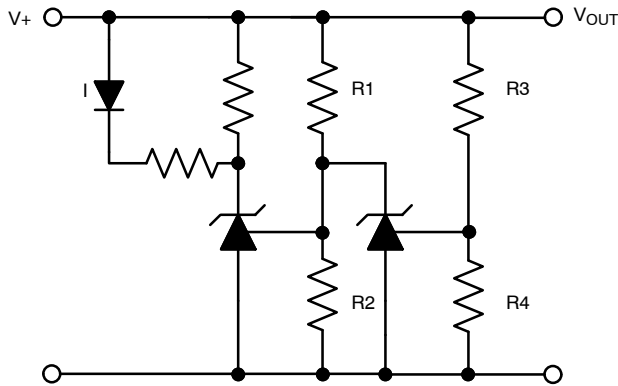

Figure 29. SRC Crowbar



L.E.D. indicator is 'on' when V_+ is between the upper and lower limits.

$$\text{Lower Limit} = \left(1 + \frac{R1}{R2}\right) V_{ref}$$

$$\text{Upper Limit} = \left(1 + \frac{R3}{R4}\right) V_{ref}$$

Figure 30. Voltage Monitoring

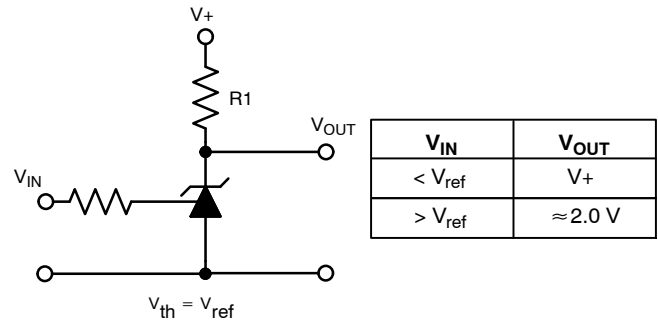

Figure 31. Single-Supply Comparator with Temperature-Compensated Threshold

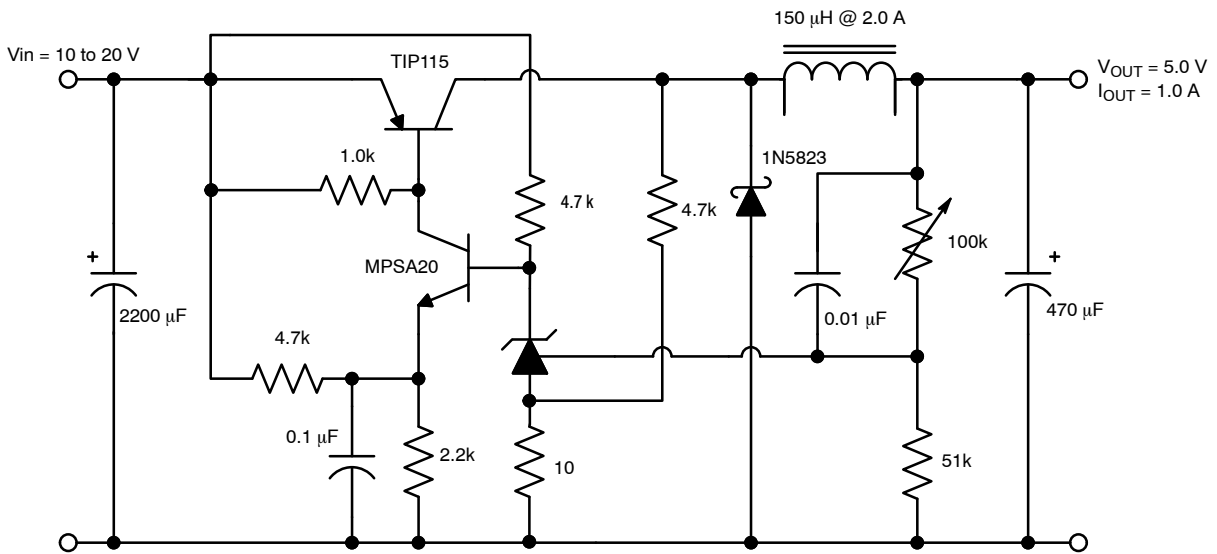

Figure 32. Step-Down Switching Converter

APPLICATIONS INFORMATION

The NCP431/NCP432 is a programmable precision reference which is used in a variety of ways. It serves as a reference voltage in circuits where a non-standard reference voltage is needed. Other uses include feedback control for driving an optocoupler in power supplies, voltage monitor, constant current source, constant current sink and series pass regulator. In each of these applications, it is critical to maintain stability of the device at various operating currents and load capacitances. In some cases the circuit designer can estimate the stabilization capacitance from the stability boundary conditions curve provided in Figure 18. However, these typical curves only provide stability information at specific cathode voltages and at a specific load condition. Additional information is needed to determine the capacitance needed to optimize phase margin or allow for process variation.

A simplified model of the NCP431/NCP432 is shown in Figure 33. When tested for stability boundaries, the load resistance is 150 Ω. The model reference input consists of an input transistor and a dc emitter resistance connected to the device anode. A dependent current source, G_m, develops a current whose amplitude is determined by the difference between the 1.78 V internal reference voltage source and the input transistor emitter voltage. A portion of G_m flows through compensation capacitance, CP2. The voltage across CP2 drives the output dependent current source, Go, which is connected across the device cathode and anode.

Model component values are:

V_{ref} = 1.78 V

G_m = 0.3 + 2.7 exp (-IC/26 mA)

where IC is the device cathode current and G_m is in mhos

Go = 1.25 (V_{cp2}) μmhos.

Resistor and capacitor typical values are shown on the model. Process tolerances are ±20% for resistors, ±10% for capacitors, and ±40% for transconductances.

An examination of the device model reveals the location of circuit poles and zeroes:

$$P_1 = \frac{1}{2\pi R_{GM} C_{P1}} = \frac{1}{2\pi \cdot 1.0M \cdot 20 \text{ pF}} = 7.96 \text{ kHz}$$

$$P_2 = \frac{1}{2\pi R_{P2} C_{P2}} = \frac{1}{2\pi \cdot 10M \cdot 0.265 \text{ pF}} = 60 \text{ kHz}$$

$$Z_1 = \frac{1}{2\pi R_{Z1} C_{P1}} = \frac{1}{2\pi \cdot 15.9k \cdot 20 \text{ pF}} = 500 \text{ kHz}$$

In addition, there is an external circuit pole defined by the load:

$$P_L = \frac{1}{2\pi R_L C_L}$$

Also, the transfer dc voltage gain of the NCP431 is:

$$G = G_M R_{GM} G_o R_L$$

Example 1:

I_C=10 mA, R_L= 230 Ω, C_L= 0. Define the transfer gain.

The DC gain is:

$$G = G_M R_{GM} G_o R_L = (2.138)(1.0M)(1.25\mu)(230) = 615 = 56 \text{ dB}$$

$$\text{Loop gain} = G \frac{8.25k}{8.25k + 15k} = 218 = 47 \text{ dB}$$

The resulting transfer function Bode plot is shown in Figure 34. The asymptotic plot may be expressed as the following equation:

$$A_v = 615 \frac{\left(1 + \frac{jf}{500 \text{ kHz}}\right)}{\left(1 + \frac{jf}{8.0 \text{ kHz}}\right)\left(1 + \frac{jf}{60 \text{ kHz}}\right)}$$

The Bode plot shows a unity gain crossover frequency of approximately 600 kHz. The phase margin, calculated from the equation, would be 55.9°. This model matches the Open-Loop Bode Plot of Figure 15. The total loop would have a unity gain frequency of about 300 kHz with a phase margin of about 44°.

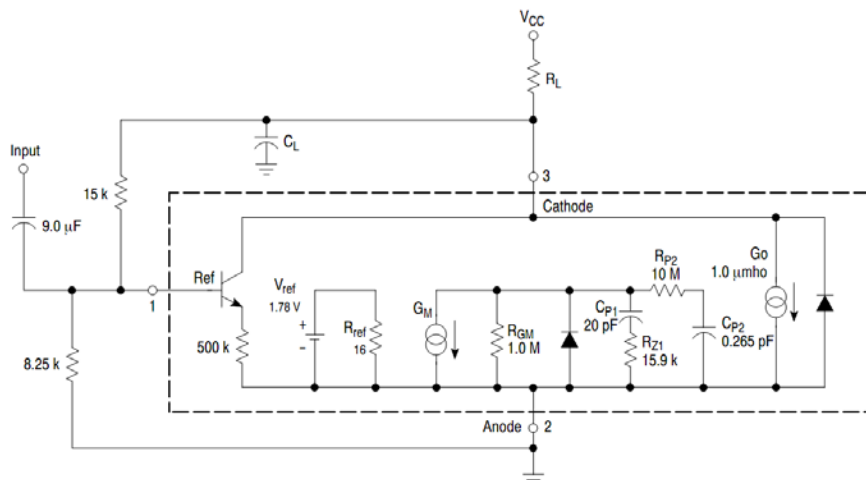

Figure 33. Simplified NCP431/NCP432 Device Model

NCP431A, SC431A, NCP431B, SC431B, NCP432B, SC432B Series

NCP431/NCP432 OPEN-LOOP VOLTAGE GAIN VERSUS FREQUENCY

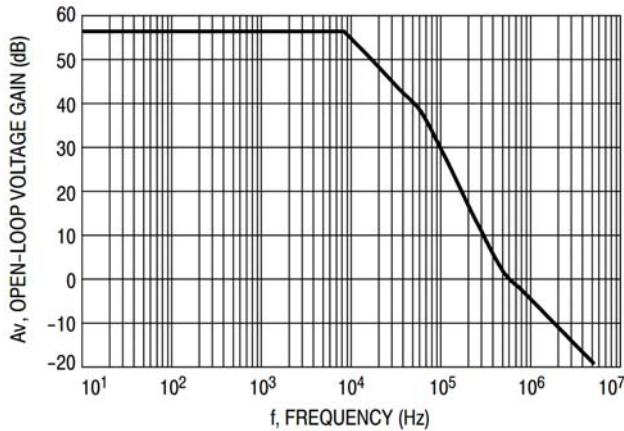

Figure 34. Example 1 Circuit Open Loop Gain Plot

Example 2.

$I_C = 7.5 \text{ mA}$, $R_L = 2.2 \text{ k}\Omega$, $C_L = 0.01 \text{ }\mu\text{F}$. Cathode tied to reference input pin. An examination of the data sheet stability boundary curve (Figure 18) shows that this value of load capacitance and cathode current is on the boundary.

Define the transfer gain.

The DC gain is:

$$G = G_M R_{GM} G_O R_L = (2.138)(1.0M)(1.25\mu)(230) = 6389 = 76 \text{ dB}$$

The resulting open loop Bode plot is shown in Figure 35. The asymptotic plot may be expressed as the following equation:

$$A_v = 615 \frac{\left(1 + \frac{jf}{500 \text{ kHz}}\right)}{\left(1 + \frac{jf}{8.0 \text{ kHz}}\right)\left(1 + \frac{jf}{60 \text{ kHz}}\right)\left(1 + \frac{jf}{7.2 \text{ kHz}}\right)}$$

Note that the transfer function now has an extra pole formed by the load capacitance and load resistance.

Note that the crossover frequency in this case is about 250 kHz, having a phase margin of about -46° . Therefore, instability of this circuit is likely.

NCP431/NCP432 OPEN-LOOP BODE PLOT WITH LOAD CAP

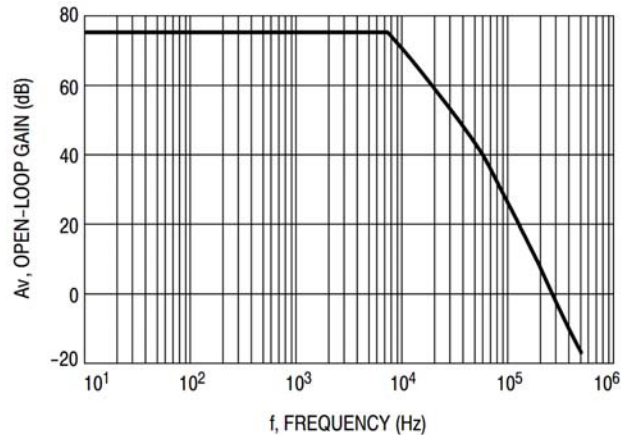

Figure 35. Example 2 Circuit Open Loop Gain Plot

With three poles, this system is unstable. The only hope for stabilizing this circuit is to add a zero. However, that can only be done by adding a series resistance to the output capacitance, which will reduce its effectiveness as a noise filter. Therefore, practically, in reference voltage applications, the best solution appears to be to use a smaller value of capacitance in low noise applications or a very large value to provide noise filtering and a dominant pole rolloff of the system.

The NCP431/NCP432 is often used as a regulator in secondary side of a switch mode power supply (SMPS).

The benefit of this reference is high and stable gain under low bias currents. Figure 36 shows dependence of the gain (dynamic impedance) on the bias current. Value of minimum cathode current that is needed to assure stable gain is $80 \text{ }\mu\text{A}$ maximum.

NCP431A, SC431A, NCP431B, SC431B, NCP432B, SC432B Series

MARKING DIAGRAMS

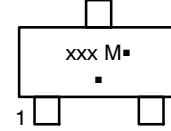
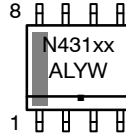
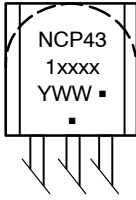

xx, xxx, xxx = Specific Device Code
 A = Assembly Location
 L = Wafer Lot
 Y = Year
 M = Date Code
 W, WW = Work Week
 ■ = Pb-Free Package

(Note: Microdot may be in either location)

ORDERING INFORMATION

Device	Marking	Tolerance	Operating Temperature Range	Package	Shipping [†]
NCP431ACDR2G	AC	1%	0°C to 70°C	SOIC-8 (Pb-Free)	2500 / Tape & Reel
NCP431ACSNT1G	VRF	1%		SOT-23-3 (Pb-Free)	3000 / Tape & Reel
NCP431BCSNT1G	VRJ	0.5%		SOT-23-3 (Pb-Free)	3000 / Tape & Reel
NCP432BCSNT1G	VRM	0.5%		SOT-23-3 (Pb-Free)	3000 / Tape & Reel
NCP431ACLPRAG	ACLP	1%		TO-92 (TO-226) (Pb-Free)	2000 / Tape & Reel
NCP431AIDR2G	AI	1%	-40°C to 85°C	SOIC-8 (Pb-Free)	2500 / Tape & Reel
NCP431AISNT1G	VRG	1%		SOT-23-3 (Pb-Free)	3000 / Tape & Reel
NCP431BISNT1G	VRK	0.5%		SOT-23-3 (Pb-Free)	3000 / Tape & Reel
NCP432BISNT1G	VRN	0.5%		SOT-23-3 (Pb-Free)	3000 / Tape & Reel
NCP431AILPRAG	AILP	1%		TO-92 (TO-226) (Pb-Free)	2000 / Tape & Reel
NCP431AVDR2G	AV	1%	-40°C to 125°C	SOIC-8 (Pb-Free)	2500 / Tape & Reel
NCP431AVSNT1G / SC431AVSNT1G*	VRH	1%		SOT-23-3 (Pb-Free)	3000 / Tape & Reel
NCP431AVLPRAG	AVLP	1%		TO-92 (TO-226) (Pb-Free)	2000 / Tape & Reel
NCP431AVLPG	AVLP	1%		TO-92 (TO-226) (Pb-Free)	2000 Units / Bag
NCP431BVSNT1G / SC431BVSNT1G*	VRL	0.5%		SOT-23-3 (Pb-Free)	3000 / Tape & Reel
NCP432BVSNT1G / SC432BVSNT1G*	VRP	0.5%		SOT-23-3 (Pb-Free)	3000 / Tape & Reel

[†]For information on tape and reel specifications, including part orientation and tape sizes, please refer to our Tape and Reel Packaging Specifications Brochure, BRD8011/D.

*SC Prefix for Automotive and Other Applications Requiring Unique Site and Control Change Requirements; AEC-Q100 Qualified and PPAP Capable.

PACKAGE DIMENSIONS

TO-92 (TO-226)
CASE 29-11
ISSUE AN

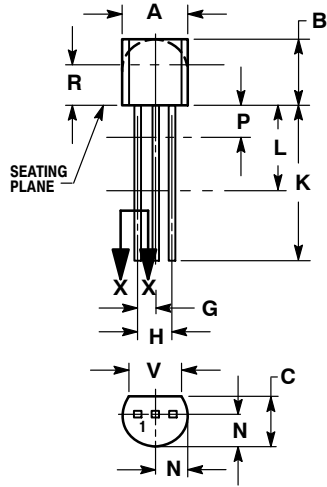

STRAIGHT LEAD
BULK PACK

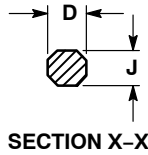

SECTION X-X

NOTES:

1. DIMENSIONING AND TOLERANCING PER ANSI Y14.5M, 1982.
2. CONTROLLING DIMENSION: INCH.
3. CONTOUR OF PACKAGE BEYOND DIMENSION R IS UNCONTROLLED.
4. LEAD DIMENSION IS UNCONTROLLED IN P AND BEYOND DIMENSION K MINIMUM.

DIM	INCHES		MILLIMETERS	
	MIN	MAX	MIN	MAX
A	0.175	0.205	4.45	5.20
B	0.170	0.210	4.32	5.33
C	0.125	0.165	3.18	4.19
D	0.016	0.021	0.407	0.533
G	0.045	0.055	1.15	1.39
H	0.095	0.105	2.42	2.66
J	0.015	0.020	0.39	0.50
K	0.500	---	12.70	---
L	0.250	---	6.35	---
N	0.080	0.105	2.04	2.66
P	---	0.100	---	2.54
R	0.115	---	2.93	---
V	0.135	---	3.43	---

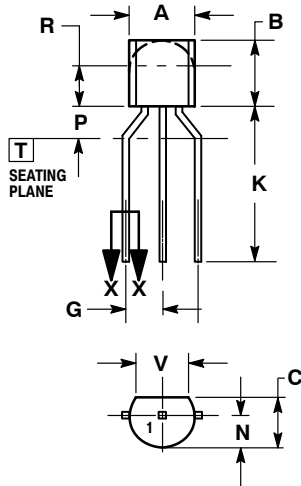

BENT LEAD
TAPE & REEL
AMMO PACK

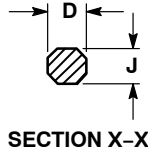

SECTION X-X

NOTES:

1. DIMENSIONING AND TOLERANCING PER ASME Y14.5M, 1994.
2. CONTROLLING DIMENSION: MILLIMETERS.
3. CONTOUR OF PACKAGE BEYOND DIMENSION R IS UNCONTROLLED.
4. LEAD DIMENSION IS UNCONTROLLED IN P AND BEYOND DIMENSION K MINIMUM.

DIM	MILLIMETERS	
	MIN	MAX
A	4.45	5.20
B	4.32	5.33
C	3.18	4.19
D	0.40	0.54
G	2.40	2.80
J	0.39	0.50
K	12.70	---
N	2.04	2.66
P	1.50	4.00
R	2.93	---
V	3.43	---

NCP431A, SC431A, NCP431B, SC431B, NCP432B, SC432B Series

PACKAGE DIMENSIONS

SOIC-8 NB
CASE 751-07
ISSUE AK



NOTES:

1. DIMENSIONING AND TOLERANCING PER ANSI Y14.5M, 1982.
2. CONTROLLING DIMENSION: MILLIMETER.
3. DIMENSION A AND B DO NOT INCLUDE MOLD PROTRUSION.
4. MAXIMUM MOLD PROTRUSION 0.15 (0.006) PER SIDE.
5. DIMENSION D DOES NOT INCLUDE DAMBAR PROTRUSION. ALLOWABLE DAMBAR PROTRUSION SHALL BE 0.127 (0.005) TOTAL IN EXCESS OF THE D DIMENSION AT MAXIMUM MATERIAL CONDITION.
6. 751-01 THRU 751-06 ARE OBSOLETE. NEW STANDARD IS 751-07.

DIM	MILLIMETERS		INCHES	
	MIN	MAX	MIN	MAX
A	4.80	5.00	0.189	0.197
B	3.80	4.00	0.150	0.157
C	1.35	1.75	0.053	0.069
D	0.33	0.51	0.013	0.020
G	1.27 BSC		0.050 BSC	
H	0.10	0.25	0.004	0.010
J	0.19	0.25	0.007	0.010
K	0.40	1.27	0.016	0.050
M	0°	8°	0°	8°
N	0.25	0.50	0.010	0.020
S	5.80	6.20	0.228	0.244

SOLDERING FOOTPRINT*

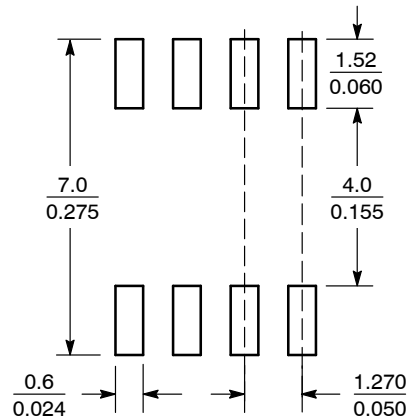

SCALE 6:1 $\left(\frac{\text{mm}}{\text{inches}}\right)$

*For additional information on our Pb-Free strategy and soldering details, please download the ON Semiconductor Soldering and Mounting Techniques Reference Manual, SOLDERRM/D.

NCP431A, SC431A, NCP431B, SC431B, NCP432B, SC432B Series

PACKAGE DIMENSIONS

SOT-23 (TO-236)
CASE 318-08
ISSUE AS

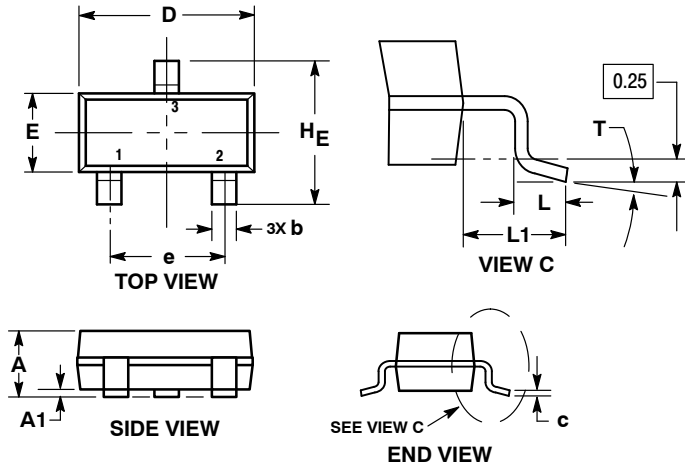

NOTES:

1. DIMENSIONING AND TOLERANCING PER ASME Y14.5M, 1994.
2. CONTROLLING DIMENSION: MILLIMETERS.
3. MAXIMUM LEAD THICKNESS INCLUDES LEAD FINISH. MINIMUM LEAD THICKNESS IS THE MINIMUM THICKNESS OF THE BASE MATERIAL.
4. DIMENSIONS D AND E DO NOT INCLUDE MOLD FLASH, PROTRUSIONS, OR GATE BURRS.

DIM	MILLIMETERS			INCHES		
	MIN	NOM	MAX	MIN	NOM	MAX
A	0.89	1.00	1.11	0.035	0.039	0.044
A1	0.01	0.06	0.10	0.000	0.002	0.004
b	0.37	0.44	0.50	0.015	0.017	0.020
c	0.08	0.14	0.20	0.003	0.006	0.008
D	2.80	2.90	3.04	0.110	0.114	0.120
E	1.20	1.30	1.40	0.047	0.051	0.055
e	1.78	1.90	2.04	0.070	0.075	0.080
L	0.30	0.43	0.55	0.012	0.017	0.022
L1	0.35	0.54	0.69	0.014	0.021	0.027
HE	2.10	2.40	2.64	0.083	0.094	0.104
T	0°	---	10°	0°	---	10°

RECOMMENDED SOLDERING FOOTPRINT*

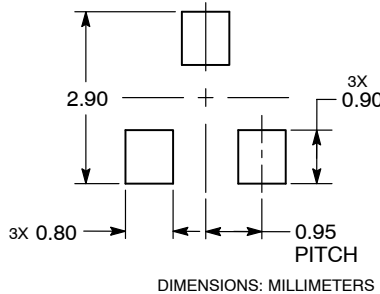

DIMENSIONS: MILLIMETERS

*For additional information on our Pb-Free strategy and soldering details, please download the ON Semiconductor Soldering and Mounting Techniques Reference Manual, SOLDERRM/D.

ON Semiconductor and are trademarks of Semiconductor Components Industries, LLC dba ON Semiconductor or its subsidiaries in the United States and/or other countries. ON Semiconductor owns the rights to a number of patents, trademarks, copyrights, trade secrets, and other intellectual property. A listing of ON Semiconductor's product/patent coverage may be accessed at www.onsemi.com/site/pdf/Patent-Marking.pdf. ON Semiconductor reserves the right to make changes without further notice to any products herein. ON Semiconductor makes no warranty, representation or guarantee regarding the suitability of its products for any particular purpose, nor does ON Semiconductor assume any liability arising out of the application or use of any product or circuit, and specifically disclaims any and all liability, including without limitation special, consequential or incidental damages. Buyer is responsible for its products and applications using ON Semiconductor products, including compliance with all laws, regulations and safety requirements or standards, regardless of any support or applications information provided by ON Semiconductor. "Typical" parameters which may be provided in ON Semiconductor data sheets and/or specifications can and do vary in different applications and actual performance may vary over time. All operating parameters, including "Typicals" must be validated for each customer application by customer's technical experts. ON Semiconductor does not convey any license under its patent rights nor the rights of others. ON Semiconductor products are not designed, intended, or authorized for use as a critical component in life support systems or any FDA Class 3 medical devices or medical devices with a same or similar classification in a foreign jurisdiction or any devices intended for implantation in the human body. Should Buyer purchase or use ON Semiconductor products for any such unintended or unauthorized application, Buyer shall indemnify and hold ON Semiconductor and its officers, employees, subsidiaries, affiliates, and distributors harmless against all claims, costs, damages, and expenses, and reasonable attorney fees arising out of, directly or indirectly, any claim of personal injury or death associated with such unintended or unauthorized use, even if such claim alleges that ON Semiconductor was negligent regarding the design or manufacture of the part. ON Semiconductor is an Equal Opportunity/Affirmative Action Employer. This literature is subject to all applicable copyright laws and is not for resale in any manner.

PUBLICATION ORDERING INFORMATION

LITERATURE FULFILLMENT:
Literature Distribution Center for ON Semiconductor
19521 E. 32nd Pkwy, Aurora, Colorado 80011 USA
Phone: 303-675-2175 or 800-344-3860 Toll Free USA/Canada
Fax: 303-675-2176 or 800-344-3867 Toll Free USA/Canada
Email: orderlit@onsemi.com

N. American Technical Support: 800-282-9855 Toll Free
USA/Canada
Europe, Middle East and Africa Technical Support:
Phone: 421 33 790 2910

ON Semiconductor Website: www.onsemi.com
Order Literature: <http://www.onsemi.com/orderlit>

For additional information, please contact your local Sales Representative

Looking for pricing, stock, or lifecycle information?

Click below to explore more details on WIN SOURCE:

 [View SC431AVSNT1G on WIN SOURCE](#)

 [ON Semiconductor](#) Information

Optimize Your Supply Chain with WIN SOURCE Solutions

-  Global Sourcing Solution
-  Obsolete Management
-  Cost Control Management
-  Shortage Management
-  Alternative Solution
-  Excess Inventory Management