



**THE DATASHEET OF
SN75C23243DLR**



SN65C23243, SN75C23243 3-V TO 5.5-V DUAL RS-232 PORT

SLLS513A – AUGUST 2001 – REVISED MARCH 2004

- **Single-Chip and Single-Supply Interface for Two IBM™ PC/AT Serial Ports**
- **Meet or Exceed the Requirements of TIA/EIA-232-F and ITU v.28 Standards**
- **Operate With 3-V to 5.5-V V_{CC} Supply**
- **Always-Active Noninverting Receiver Output ($\overline{ROUT2}$) Per Port**
- **Operate Up To 250 kbit/s**
- **Low Standby Current . . . 1 μ A Typical**
- **External Capacitors . . . 4 \times 0.22 μ F**
- **Accept 5-V Logic Input With 3.3-V Supply**
- **Allow for Flexible Power Down of Either Serial Port**
- **Serial-Mouse Driveability**
- **RS-232 Bus-Pin ESD Protection Exceeds ± 15 kV Using Human-Body Model (HBM)**
- **Applications**
 - **Battery-Powered Systems, Notebooks, Laptops, Palmtop PCs, and Hand-Held Equipment**

description/ordering information

The SN65C23243 and SN75C23243 consist of two ports, each containing three line drivers and five line receivers, and a dual charge-pump circuit with ± 15 -kV ESD protection pin to pin (serial-port connection pins, including GND). These devices meet the requirements of TIA/EIA-232-F and provide the electrical interface between an asynchronous communication controller and the serial-port connector. This combination of drivers and receivers matches that needed for two typical serial ports used in an IBM PC/AT, or compatible. The charge pump and four small external capacitors allow operation from a single 3-V to 5.5-V supply. In addition, these devices include an always-active noninverting output ($\overline{ROUT2}$) per port, which allows applications using the ring indicator to transmit data while the devices are powered down. The devices operate at data signaling rates up to 250 kbit/s and a maximum of 30-V/ μ s driver output slew-rate.

DGG OR DL PACKAGE (TOP VIEW)

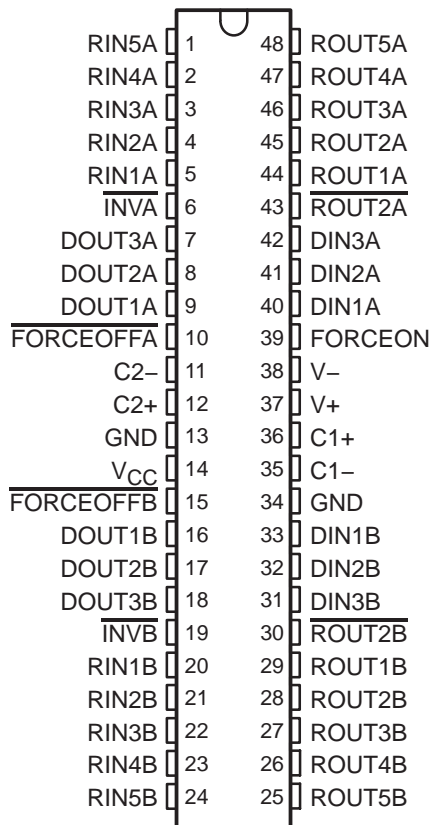

ORDERING INFORMATION

TA	PACKAGE†		ORDERABLE PART NUMBER	TOP-SIDE MARKING
–0°C to 70°C	SSOP (DL)	Tube of 25	SN75C23243DL	75C23243
		Reel of 1000	SN75C23243DLR	
	TSSOP (DGG)	Reel of 2000	SN75C23243DGGR	75C23243
–40°C to 85°C	SSOP (DL)	Tube of 25	SN65C23243DL	65C23243
		Reel of 1000	SN65C23243DLR	
	TSSOP (DGG)	Reel of 2000	SN65C23243DGGR	65C23243

† Package drawings, standard packing quantities, thermal data, symbolization, and PCB design guidelines are available at www.ti.com/sc/package.



Please be aware that an important notice concerning availability, standard warranty, and use in critical applications of Texas Instruments semiconductor products and disclaimers thereto appears at the end of this data sheet.

IBM is a trademark of International Business Machines Corporation.

PRODUCTION DATA information is current as of publication date. Products conform to specifications per the terms of Texas Instruments standard warranty. Production processing does not necessarily include testing of all parameters.



POST OFFICE BOX 655303 • DALLAS, TEXAS 75265

Copyright © 2004, Texas Instruments Incorporated

SN65C23243, SN75C23243

3-V TO 5.5-V DUAL RS-232 PORT

SLLS513A – AUGUST 2001 – REVISED MARCH 2004

description/ordering information (continued)

Flexible control options for power management are available when either or both serial ports are inactive. The auto-powerdown feature functions when FORCEON is low and $\overline{\text{FORCEOFF}}$ is high. During this mode of operation, if the device does not sense a valid RS-232 signal, the driver outputs of its respective port are disabled. If $\overline{\text{FORCEOFF}}$ is set low, both drivers and receivers (except $\overline{\text{ROUT2}}$) are shut off, and the supply current is reduced to 1 μA . Disconnecting the serial port or turning off the peripheral drivers causes the auto-powerdown condition to occur.

Auto-powerdown can be disabled when FORCEON and $\overline{\text{FORCEOFF}}$ are high and should be done when driving a serial mouse. With auto-powerdown enabled, the RS-232 port is activated automatically when a valid signal is applied to any respective receiver input. The $\overline{\text{INV}}$ output is used to notify the user if an RS-232 signal is present at any receiver input. $\overline{\text{INV}}$ is high (valid data) if any receiver input voltage is greater than 2.7 V or less than -2.7 V or has been between -0.3 V and 0.3 V for less than 30 μs . $\overline{\text{INV}}$ is low (invalid data) if all receiver input voltages are between -0.3 V and 0.3 V for more than 30 μs . Refer to Figure 5 for receiver input levels.

Function Tables

EACH DRIVER
(each port)

INPUTS				OUTPUT DOUT	DRIVER STATUS
DIN	FORCEON	$\overline{\text{FORCEOFF}}$	VALID RIN RS-232 LEVEL		
X	X	L	X	Z	Powered off
L	H	H	X	H	Normal operation with auto-powerdown disabled
H	H	H	X	L	
L	L	H	Yes	H	Normal operation with auto-powerdown enabled
H	L	H	Yes	L	
L	L	H	No	Z	Powered off by auto-powerdown feature
H	L	H	No	Z	

H = high level, L = low level, X = irrelevant, Z = high impedance

EACH RECEIVER
(each port)

INPUTS				OUTPUTS		RECEIVER STATUS
RIN2	RIN1, RIN3-RIN5	$\overline{\text{FORCEOFF}}$	VALID RIN RS-232 LEVEL	$\overline{\text{ROUT2}}$	ROUT	
L	X	L	X	L	Z	Powered off while $\overline{\text{ROUT2}}$ is active
H	X	L	X	H	Z	
L	L	H	Yes	L	H	Normal operation with auto-powerdown disabled/enabled
L	H	H	Yes	L	L	
H	L	H	Yes	H	H	
H	H	H	Yes	H	L	
Open	Open	H	No	L	H	

H = high level, L = low level, X = irrelevant, Z = high impedance (off), Open = input disconnected or connected driver off



SN65C23243, SN75C23243 3-V TO 5.5-V DUAL RS-232 PORT

SLLS513A – AUGUST 2001 – REVISED MARCH 2004

logic diagram (positive logic)

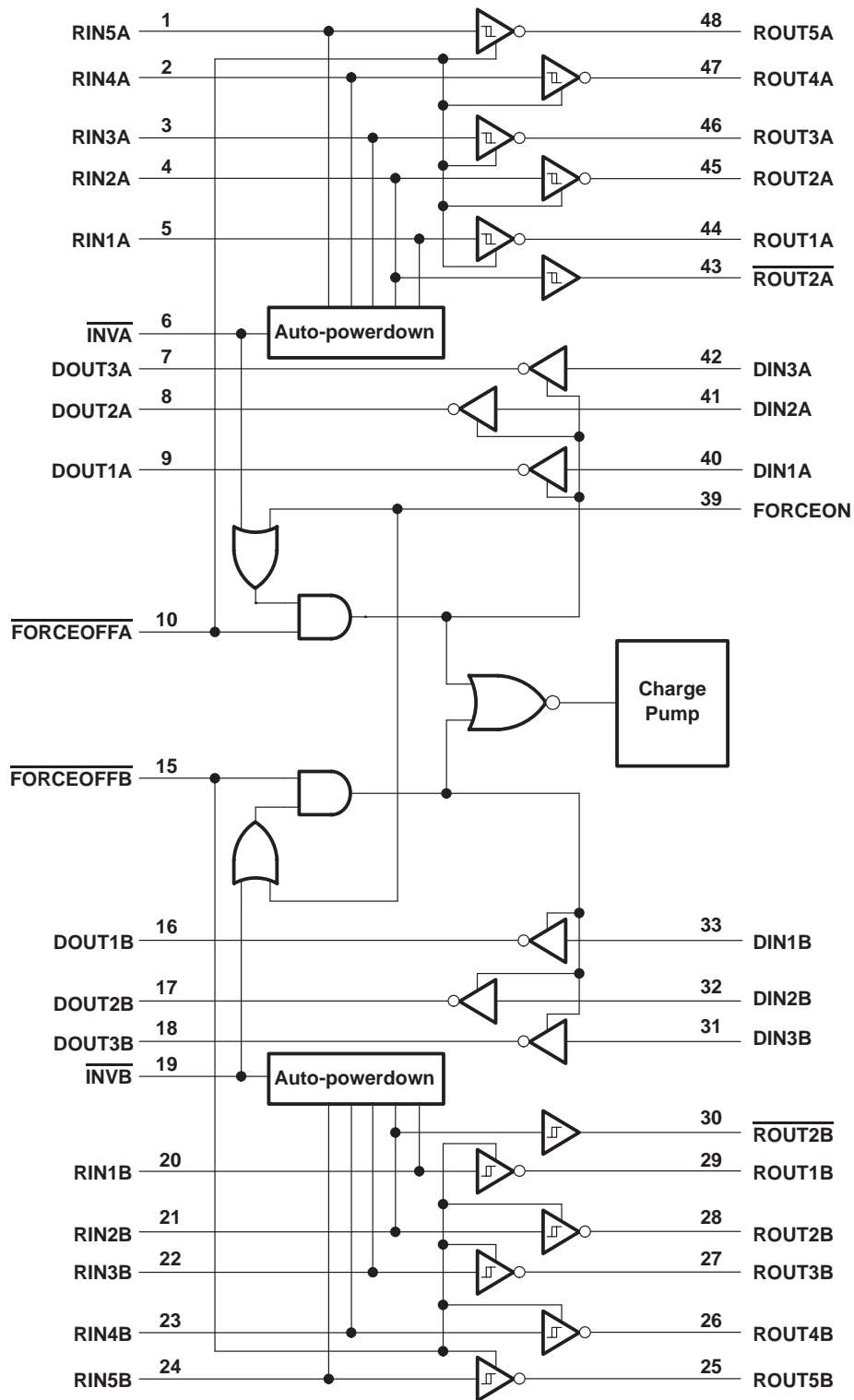

SN65C23243, SN75C23243

3-V TO 5.5-V DUAL RS-232 PORT

SLLS513A – AUGUST 2001 – REVISED MARCH 2004

timing

Figure 1 shows how the two independent serial ports can be enabled or disabled. As shown by the logic states, depending on the $\overline{\text{FORCEOFF}}$, FORCEON , and receiver input levels, either port can be powered down. Intermediate receiver input levels indicate a 0-V input. Also, it is assumed a pull-down resistor to ground is used for the receiver outputs. The $\overline{\text{INV}}$ pin goes low when its respective receiver input does not supply a valid RS-232 level. For simplicity, voltage levels, timing differences, and input/output edge rates are not shown.

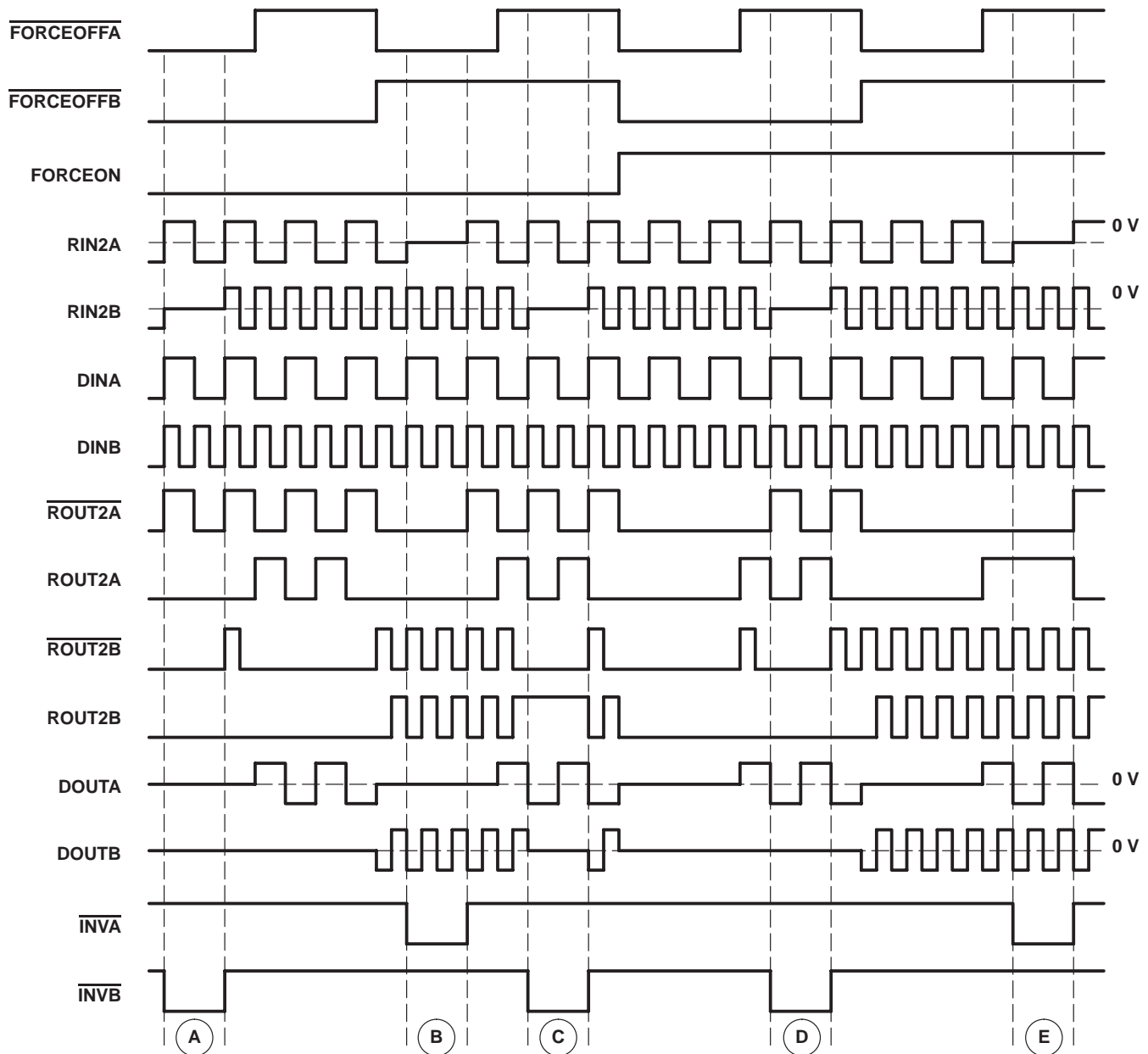

- NOTES:
- A. Ports A and B manually powered off
 - B. Port A manually powered off, port B in normal operation with auto-powerdown enabled
 - C. Port B powered off by auto-powerdown, port A in normal operation with auto-powerdown enabled
 - D. Port A in normal operation with auto-powerdown disabled, port B manually powered off
 - E. Ports A and B in normal operation with auto-powerdown disabled

Figure 1. Timing Diagram



absolute maximum ratings over operating free-air temperature range (unless otherwise noted)†

Supply voltage range, V_{CC} (see Note 1)	–0.3 V to 6 V
Positive output supply voltage range, $V+$ (see Note 1)	–0.3 V to 7 V
Negative output supply voltage, $V-$ (see Note 1)	0.3 V to –7 V
Supply voltage difference, $V+ - V-$ (see Note 1)	13 V
Input voltage range, V_I : Driver ($\overline{\text{FORCEOFF}}$, FORCEON)	–0.3 V to 6 V
Receiver	–25 V to 25 V
Output voltage range, V_O : Driver	–13.2 V to 13.2 V
Receiver ($\overline{\text{INV}}$)	–0.3 V to $V_{CC} + 0.3$ V
Package thermal impedance, θ_{JA} (see Notes 2 and 3): DGG package	70°C/W
DL package	63°C/W
Operating virtual junction temperature, T_J	150°C
Storage temperature range, T_{stg}	–65°C to 150°C

† Stresses beyond those listed under “absolute maximum ratings” may cause permanent damage to the device. These are stress ratings only, and functional operation of the device at these or any other conditions beyond those indicated under “recommended operating conditions” is not implied. Exposure to absolute-maximum-rated conditions for extended periods may affect device reliability.

- NOTES: 1. All voltages are with respect to network GND.
 2. Maximum power dissipation is a function of $T_J(\text{max})$, θ_{JA} , and T_A . The maximum allowable power dissipation at any allowable ambient temperature is $P_D = (T_J(\text{max}) - T_A)/\theta_{JA}$. Operating at the absolute maximum T_J of 150°C can affect reliability.
 3. The package thermal impedance is calculated in accordance with JESD 51-7.

recommended operating conditions (see Note 4 and Figure 7)

		MIN	NOM	MAX	UNIT
Supply voltage	$V_{CC} = 3.3$ V	3	3.3	3.6	V
	$V_{CC} = 5$ V	4.5	5	5.5	
Driver and control high-level input voltage, V_{IH}	DIN, $\overline{\text{FORCEOFF}}$, FORCEON	$V_{CC} = 3.3$ V			V
		$V_{CC} = 5$ V			
Driver and control low-level input voltage, V_{IL}	DIN, $\overline{\text{FORCEOFF}}$, FORCEON				0.8
Driver and control input voltage, V_I	DIN, $\overline{\text{FORCEOFF}}$, FORCEON	0			5.5
Receiver input voltage, V_I	RIN	–25			25
Operating free-air temperature, T_A	SN75C23243	0			70
	SN65C23243	–40			85

NOTE 4: Test conditions are C1–C4 = 0.22 μ F at $V_{CC} = 3.3$ V \pm 0.3 V; C1 = 0.047 μ F, C2–C4 = 0.33 μ F at $V_{CC} = 5$ V \pm 0.5 V.

electrical characteristics over recommended ranges of supply voltage and operating free-air temperature (unless otherwise noted) (see Note 4 and Figure 7)

PARAMETER		TEST CONDITIONS	MIN	TYP‡	MAX	UNIT
I_I	Input leakage current	$\overline{\text{FORCEOFF}}$, FORCEON	± 0.01		± 1	μ A
I_{CC}	Supply current ($T_A = 25^\circ\text{C}$)	Auto-powerdown disabled	No load, $\overline{\text{FORCEOFF}}$ and FORCEON at V_{CC}		0.6	2
		Powered off	No load, $\overline{\text{FORCEOFF}}$ at GND		1	20
		Auto-powerdown enabled	No load, $\overline{\text{FORCEOFF}}$ at V_{CC} , FORCEON at GND, All RIN are open or grounded		1	20

‡ All typical values are at $V_{CC} = 3.3$ V or $V_{CC} = 5$ V and $T_A = 25^\circ\text{C}$.

NOTE 4: Test conditions are C1–C4 = 0.22 μ F at $V_{CC} = 3.3$ V \pm 0.3 V; C1 = 0.047 μ F, C2–C4 = 0.33 μ F at $V_{CC} = 5$ V \pm 0.5 V.

SN65C23243, SN75C23243

3-V TO 5.5-V DUAL RS-232 PORT

SLLS513A – AUGUST 2001 – REVISED MARCH 2004

DRIVER SECTION

electrical characteristics over recommended ranges of supply voltage and operating free-air temperature (unless otherwise noted) (see Note 4 and Figure 7)

PARAMETER	TEST CONDITIONS	MIN	TYP†	MAX	UNIT	
V _{OH}	High-level output voltage	All DOUT at R _L = 3 kΩ to GND		5	5.4	V
V _{OL}	Low-level output voltage	All DOUT at R _L = 3 kΩ to GND		-5	-5.4	V
V _O	Output voltage (mouse driveability)	DIN1 = DIN2 = GND, DIN3 = V _{CC} , 3-kΩ to GND at DOUT3, DOUT1 = DOUT2 = -2.5 mA		±5		V
I _{IH}	High-level input current	V _I = V _{CC}		±0.01	±1	μA
I _{IL}	Low-level input current	V _I at GND		±0.01	±1	μA
I _{OS}	Short-circuit output current‡	V _{CC} = 3.6 V, V _O = 0 V		±35	±60	mA
		V _{CC} = 5.5 V, V _O = 0 V				
r _o	Output resistance	V _{CC} , V+, and V- = 0 V, V _O = ±2 V		300	10M	Ω
I _{off}	Output leakage current	FORCEOFF = GND	V _O = ±12 V, V _{CC} = 3 V to 3.6 V	±25		μA
			V _O = ±10 V, V _{CC} = 4.5 V to 5.5 V	±25		

† All typical values are at V_{CC} = 3.3 V or V_{CC} = 5 V and T_A = 25°C.

‡ Short-circuit durations should be controlled to prevent exceeding the device absolute power dissipation ratings, and not more than one output should be shorted at a time.

NOTE 4: Test conditions are C1–C4 = 0.22 μF at V_{CC} = 3.3 V ± 0.3 V; C1 = 0.047 μF, C2–C4 = 0.33 μF at V_{CC} = 5 V ± 0.5 V.

switching characteristics over recommended ranges of supply voltage and operating free-air temperature (unless otherwise noted) (see Note 4 and Figure 7)

PARAMETER	TEST CONDITIONS	MIN	TYP†	MAX	UNIT	
Maximum data rate	C _L = 1000 pF, One DOUT switching, R _L = 3 kΩ, See Figure 1	250			kbit/s	
t _{sk(p)}	Pulse skew§	C _L = 150 pF to 2500 pF	R _L = 3 kΩ to 7 kΩ, See Figure 2	100		ns
SR(tr)	Slew rate, transition region (see Figure 1)	V _{CC} = 3.3 V, R _L = 3 kΩ to 7 kΩ	C _L = 150 pF to 1000 pF	6	30	V/μs
			C _L = 150 pF to 2500 pF	4	30	

† All typical values are at V_{CC} = 3.3 V or V_{CC} = 5 V and T_A = 25°C.

§ Pulse skew is defined as |t_{PLH} - t_{PHL}| of each channel of the same device.

NOTE 4: Test conditions are C1–C4 = 0.22 μF at V_{CC} = 3.3 V ± 0.3 V; C1 = 0.047 μF, C2–C4 = 0.33 μF at V_{CC} = 5 V ± 0.5 V.



RECEIVER SECTION

electrical characteristics over recommended ranges of supply voltage and operating free-air temperature (unless otherwise noted) (see Note 4 and Figure 7)

PARAMETER	TEST CONDITIONS	MIN	TYP†	MAX	UNIT
V _{OH} High-level output voltage	I _{OH} = -1 mA	V _{CC} - 0.6 V	V _{CC} - 0.1 V		V
V _{OL} Low-level output voltage	I _{OL} = 1.6 mA			0.4	V
V _{IT+} Positive-going input threshold voltage	V _{CC} = 3.3 V		1.6	2.4	V
	V _{CC} = 5 V		1.9	2.4	
V _{IT-} Negative-going input threshold voltage	V _{CC} = 3.3 V	0.6	1.1		V
	V _{CC} = 5 V	0.8	1.4		
V _{hys} Input hysteresis (V _{IT+} - V _{IT-})			0.5		V
I _{off} Output leakage current (except ROUT2B)	FORCEOFF = 0 V		±0.05	±10	µA
r _i Input resistance	V _I = ±3 V to ±25 V	3	5	7	kΩ

† All typical values are at V_{CC} = 3.3 V or V_{CC} = 5 V and T_A = 25°C.

NOTE 4: Test conditions are C1–C4 = 0.22 µF at V_{CC} = 3.3 V ± 0.3 V; C1 = 0.047 µF, C2–C4 = 0.33 µF at V_{CC} = 5 V ± 0.5 V.

switching characteristics over recommended ranges of supply voltage and operating free-air temperature (unless otherwise noted) (see Note 4 and Figure 7)

PARAMETER	TEST CONDITIONS	MIN	TYP†	MAX	UNIT
t _{PLH} Propagation delay time, low- to high-level output	C _L = 150 pF, See Figure 4		150		ns
t _{PHL} Propagation delay time, high- to low-level output			150		ns
t _{en} Output enable time	C _L = 150 pF, R _L = 3 kΩ, See Figure 5		200		ns
t _{dis} Output disable time			200		ns
t _{sk(p)} Pulse skew‡	See Figure 4		50		ns

† All typical values are at V_{CC} = 3.3 V or V_{CC} = 5 V and T_A = 25°C.

‡ Pulse skew is defined as |t_{PLH} - t_{PHL}| of each channel of the same device.

NOTE 4: Test conditions are C1–C4 = 0.22 µF at V_{CC} = 3.3 V ± 0.3 V; C1 = 0.047 µF, C2–C4 = 0.33 µF at V_{CC} = 5 V ± 0.5 V.

SN65C23243, SN75C23243
3-V TO 5.5-V DUAL RS-232 PORT

SLLS513A – AUGUST 2001 – REVISED MARCH 2004

AUTO-POWERDOWN SECTION

electrical characteristics over recommended ranges of supply voltage and operating free-air temperature (unless otherwise noted) (see Figure 6)

PARAMETER		TEST CONDITIONS	MIN	MAX	UNIT
$V_{T+}(\text{valid})$	Receiver input threshold for $\overline{\text{INV}}$ high-level output voltage	$\overline{\text{FORCEON}} = \text{GND},$ $\overline{\text{FORCEOFF}} = V_{\text{CC}}$		2.7	V
$V_{T-}(\text{valid})$	Receiver input threshold for $\overline{\text{INV}}$ high-level output voltage	$\overline{\text{FORCEON}} = \text{GND},$ $\overline{\text{FORCEOFF}} = V_{\text{CC}}$	-2.7		V
$V_{T}(\text{invalid})$	Receiver input threshold for $\overline{\text{INV}}$ low-level output voltage	$\overline{\text{FORCEON}} = \text{GND},$ $\overline{\text{FORCEOFF}} = V_{\text{CC}}$	-0.3	0.3	V
V_{OH}	$\overline{\text{INV}}$ high-level output voltage	$I_{\text{OH}} = -1 \text{ mA}, \overline{\text{FORCEON}} = \text{GND},$ $\overline{\text{FORCEOFF}} = V_{\text{CC}}$	$V_{\text{CC}} - 0.6$		V
V_{OL}	$\overline{\text{INV}}$ low-level output voltage	$I_{\text{OL}} = 1.6 \text{ mA}, \overline{\text{FORCEON}} = \text{GND},$ $\overline{\text{FORCEOFF}} = V_{\text{CC}}$		0.4	V

switching characteristics over recommended ranges of supply voltage and operating free-air temperature (unless otherwise noted) (see Figure 6)

PARAMETER		MIN	TYP†	MAX	UNIT
t_{valid}	Propagation delay time, low- to high-level output		1		μs
t_{invalid}	Propagation delay time, high- to low-level output		30		μs
t_{en}	Supply enable time		100		μs

† All typical values are at $V_{\text{CC}} = 3.3 \text{ V}$ or $V_{\text{CC}} = 5 \text{ V}$ and $T_{\text{A}} = 25^{\circ}\text{C}$.



PARAMETER MEASUREMENT INFORMATION

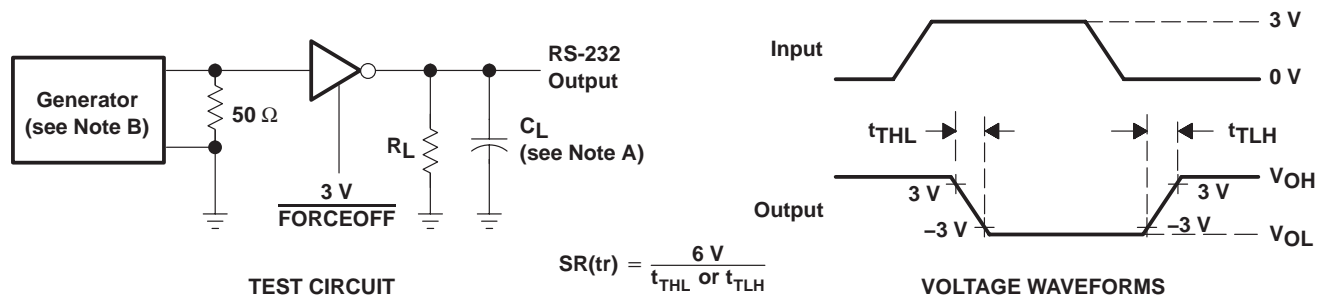

NOTES: A. C_L includes probe and jig capacitance.
B. The pulse generator has the following characteristics: PRR = 250 kbit/s, $Z_O = 50 \Omega$, 50% duty cycle, $t_r \leq 10\text{ ns}$, $t_f \leq 10\text{ ns}$.

Figure 2. Driver Slew Rate

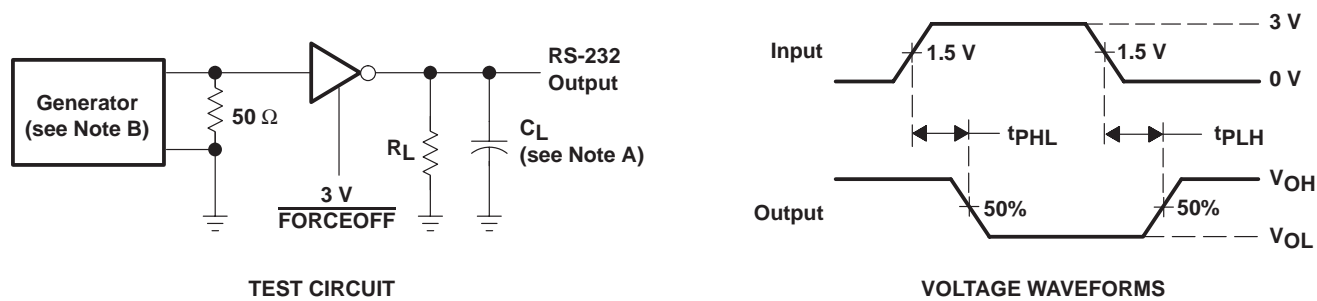

NOTES: A. C_L includes probe and jig capacitance.
B. The pulse generator has the following characteristics: PRR = 250 kbit/s, $Z_O = 50 \Omega$, 50% duty cycle, $t_r \leq 10\text{ ns}$, $t_f \leq 10\text{ ns}$.

Figure 3. Driver Pulse Skew

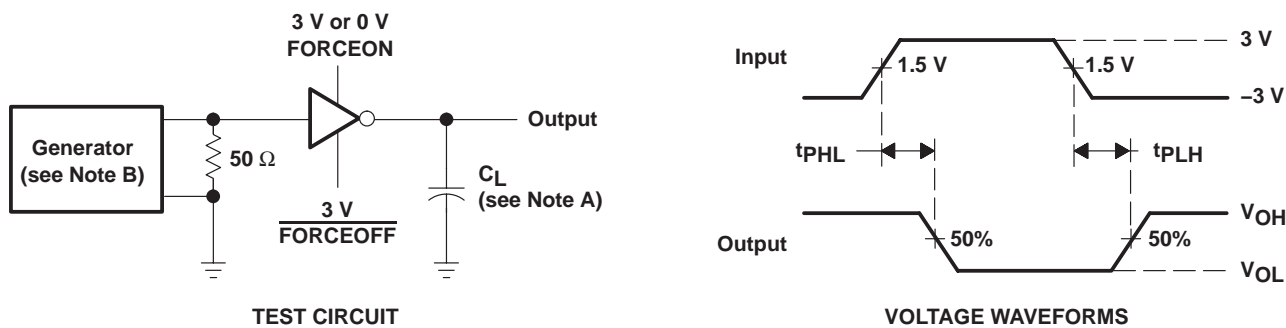

NOTES: A. C_L includes probe and jig capacitance.
B. The pulse generator has the following characteristics: $Z_O = 50 \Omega$, 50% duty cycle, $t_r \leq 10\text{ ns}$, $t_f \leq 10\text{ ns}$.

Figure 4. Receiver Propagation Delay Times

SN65C23243, SN75C23243 3-V TO 5.5-V DUAL RS-232 PORT

SLLS513A – AUGUST 2001 – REVISED MARCH 2004

PARAMETER MEASUREMENT INFORMATION

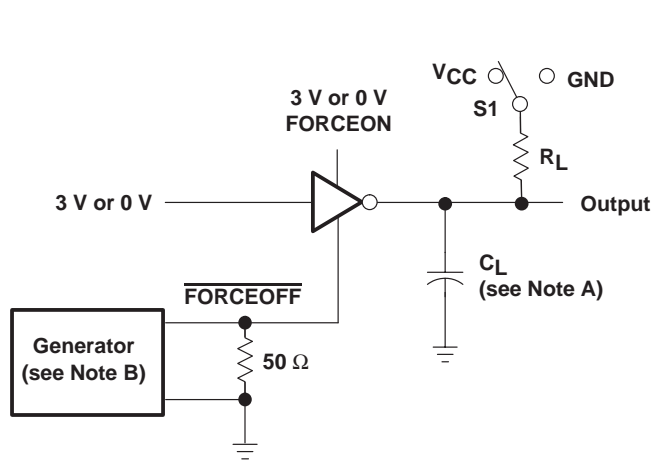

TEST CIRCUIT

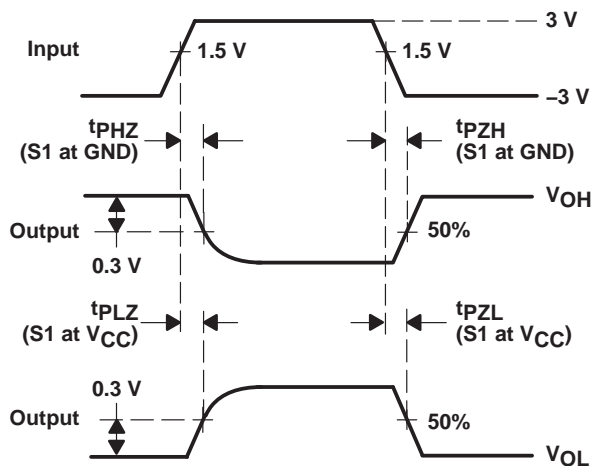

VOLTAGE WAVEFORMS

- NOTES:
- A. C_L includes probe and jig capacitance.
 - B. The pulse generator has the following characteristics: $Z_O = 50 \Omega$, 50% duty cycle, $t_r \leq 10 \text{ ns}$, $t_f \leq 10 \text{ ns}$.
 - C. t_{PLZ} and t_{PHZ} are the same as t_{dis} .
 - D. t_{PZL} and t_{PZH} are the same as t_{en} .

Figure 5. Receiver Enable and Disable Times

PARAMETER MEASUREMENT INFORMATION

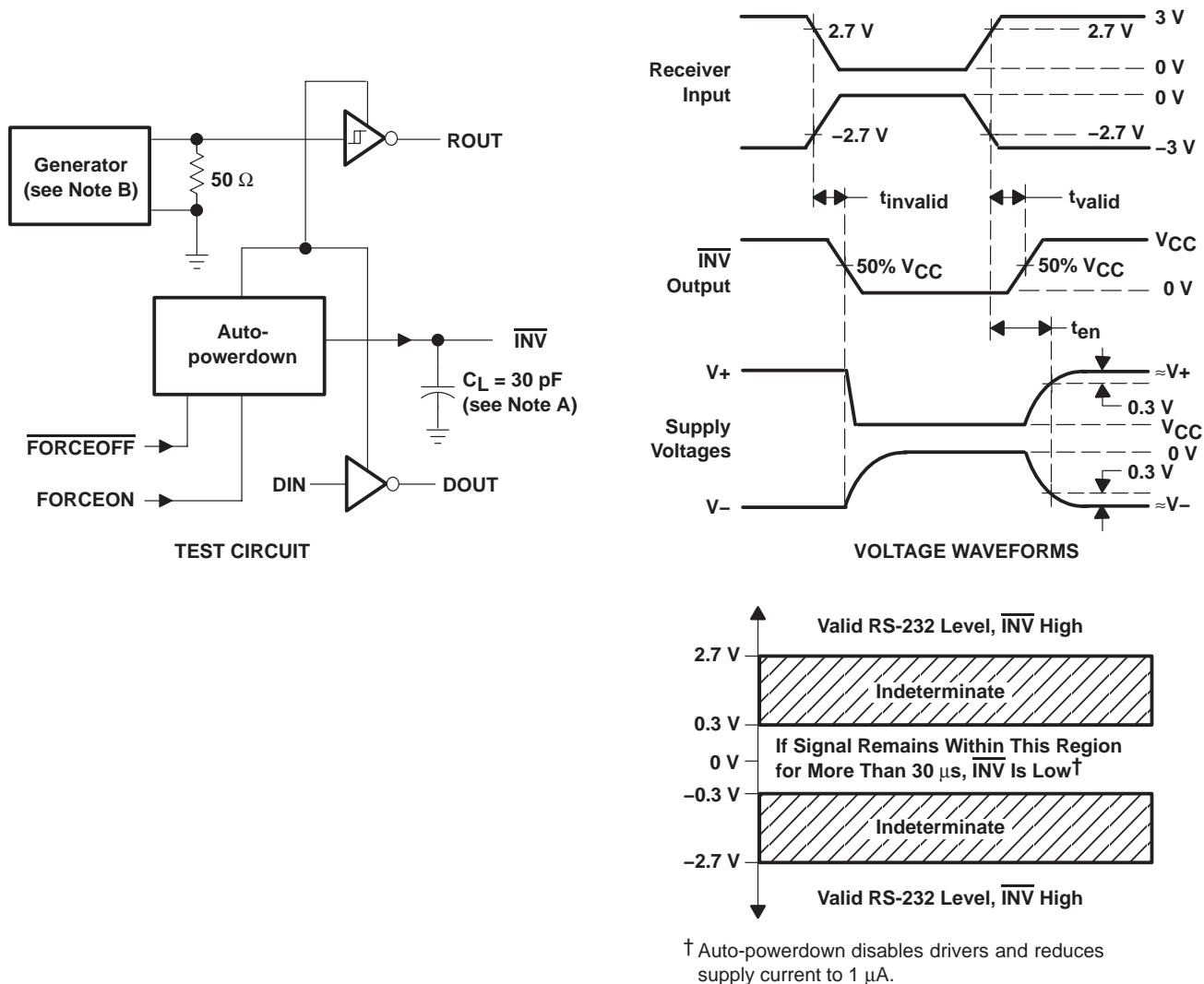

† Auto-powerdown disables drivers and reduces supply current to 1 μA .

- NOTES: A. C_L includes probe and jig capacitance.
B. The pulse generator has the following characteristics: PRR = 5 kbit/s, $Z_O = 50 \Omega$, 50% duty cycle, $t_r \leq 10 \text{ ns}$, $t_f \leq 10 \text{ ns}$.

Figure 6. \overline{INV} Propagation Delay Times and Supply Enabling Time

SN65C23243, SN75C23243 3-V TO 5.5-V DUAL RS-232 PORT

SLLS513A – AUGUST 2001 – REVISED MARCH 2004

APPLICATION INFORMATION

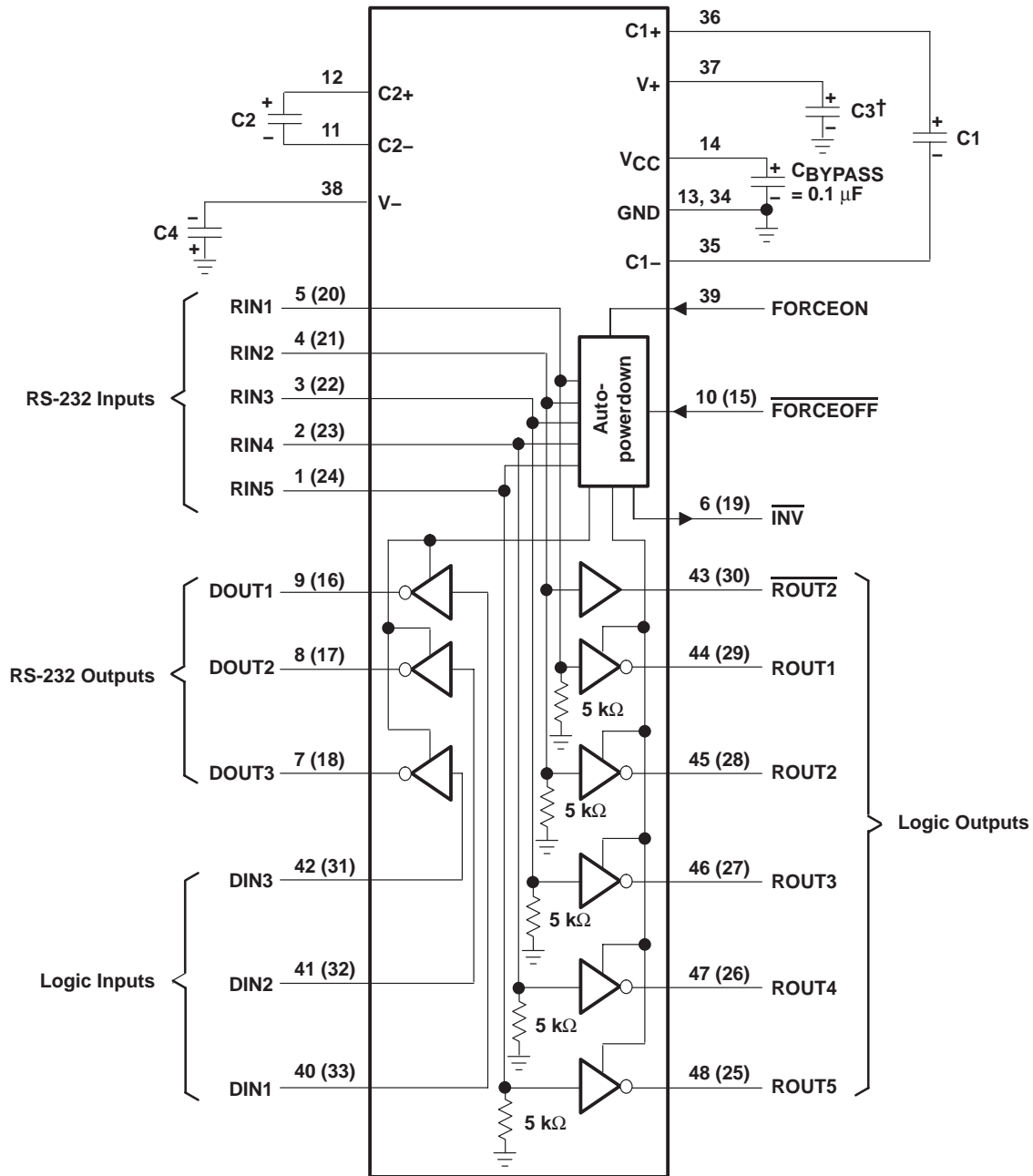

† C3 can be connected to V_{CC} or GND.

- NOTES: A. Resistor values shown are nominal.
B. Numbers in parentheses are for B section.

V_{CC} vs CAPACITOR VALUES

V _{CC}	C1	C2, C3, and C4
3.3 V ± 0.3 V	0.22 μF	0.22 μF
5 V ± 0.5 V	0.047 μF	0.33 μF
3 V to 5.5 V	0.22 μF	1 μF

Figure 7. Typical Operating Circuit and Capacitor Values



POST OFFICE BOX 655303 • DALLAS, TEXAS 75265

PACKAGING INFORMATION

Orderable Device	Status ⁽¹⁾	Package Type	Package Drawing	Pins	Package Qty	Eco Plan ⁽²⁾	Lead/Ball Finish	MSL Peak Temp ⁽³⁾
SN65C23243DGGR	ACTIVE	TSSOP	DGG	48	2000	Green (RoHS & no Sb/Br)	CU NIPDAU	Level-1-260C-UNLIM
SN65C23243DGGRE4	ACTIVE	TSSOP	DGG	48	2000	Green (RoHS & no Sb/Br)	CU NIPDAU	Level-1-260C-UNLIM
SN65C23243DGGRG4	ACTIVE	TSSOP	DGG	48	2000	Green (RoHS & no Sb/Br)	CU NIPDAU	Level-1-260C-UNLIM
SN65C23243DL	ACTIVE	SSOP	DL	48	25	Green (RoHS & no Sb/Br)	CU NIPDAU	Level-1-260C-UNLIM
SN65C23243DLG4	ACTIVE	SSOP	DL	48	25	Green (RoHS & no Sb/Br)	CU NIPDAU	Level-1-260C-UNLIM
SN65C23243DLR	ACTIVE	SSOP	DL	48	1000	Green (RoHS & no Sb/Br)	CU NIPDAU	Level-1-260C-UNLIM
SN65C23243DLRG4	ACTIVE	SSOP	DL	48	1000	Green (RoHS & no Sb/Br)	CU NIPDAU	Level-1-260C-UNLIM
SN75C23243DGGR	ACTIVE	TSSOP	DGG	48	2000	Green (RoHS & no Sb/Br)	CU NIPDAU	Level-1-260C-UNLIM
SN75C23243DGGRE4	ACTIVE	TSSOP	DGG	48	2000	Green (RoHS & no Sb/Br)	CU NIPDAU	Level-1-260C-UNLIM
SN75C23243DGGRG4	ACTIVE	TSSOP	DGG	48	2000	Green (RoHS & no Sb/Br)	CU NIPDAU	Level-1-260C-UNLIM
SN75C23243DL	ACTIVE	SSOP	DL	48	25	Green (RoHS & no Sb/Br)	CU NIPDAU	Level-1-260C-UNLIM
SN75C23243DLG4	ACTIVE	SSOP	DL	48	25	Green (RoHS & no Sb/Br)	CU NIPDAU	Level-1-260C-UNLIM
SN75C23243DLR	ACTIVE	SSOP	DL	48	1000	Green (RoHS & no Sb/Br)	CU NIPDAU	Level-1-260C-UNLIM
SN75C23243DLRG4	ACTIVE	SSOP	DL	48	1000	Green (RoHS & no Sb/Br)	CU NIPDAU	Level-1-260C-UNLIM

⁽¹⁾ The marketing status values are defined as follows:

ACTIVE: Product device recommended for new designs.

LIFEBUY: TI has announced that the device will be discontinued, and a lifetime-buy period is in effect.

NRND: Not recommended for new designs. Device is in production to support existing customers, but TI does not recommend using this part in a new design.

PREVIEW: Device has been announced but is not in production. Samples may or may not be available.

OBSOLETE: TI has discontinued the production of the device.

⁽²⁾ Eco Plan - The planned eco-friendly classification: Pb-Free (RoHS), Pb-Free (RoHS Exempt), or Green (RoHS & no Sb/Br) - please check <http://www.ti.com/productcontent> for the latest availability information and additional product content details.

TBD: The Pb-Free/Green conversion plan has not been defined.

Pb-Free (RoHS): TI's terms "Lead-Free" or "Pb-Free" mean semiconductor products that are compatible with the current RoHS requirements for all 6 substances, including the requirement that lead not exceed 0.1% by weight in homogeneous materials. Where designed to be soldered at high temperatures, TI Pb-Free products are suitable for use in specified lead-free processes.

Pb-Free (RoHS Exempt): This component has a RoHS exemption for either 1) lead-based flip-chip solder bumps used between the die and package, or 2) lead-based die adhesive used between the die and leadframe. The component is otherwise considered Pb-Free (RoHS compatible) as defined above.

Green (RoHS & no Sb/Br): TI defines "Green" to mean Pb-Free (RoHS compatible), and free of Bromine (Br) and Antimony (Sb) based flame retardants (Br or Sb do not exceed 0.1% by weight in homogeneous material)

⁽³⁾ MSL, Peak Temp. -- The Moisture Sensitivity Level rating according to the JEDEC industry standard classifications, and peak solder temperature.

Important Information and Disclaimer:The information provided on this page represents TI's knowledge and belief as of the date that it is

provided. TI bases its knowledge and belief on information provided by third parties, and makes no representation or warranty as to the accuracy of such information. Efforts are underway to better integrate information from third parties. TI has taken and continues to take reasonable steps to provide representative and accurate information but may not have conducted destructive testing or chemical analysis on incoming materials and chemicals. TI and TI suppliers consider certain information to be proprietary, and thus CAS numbers and other limited information may not be available for release.

In no event shall TI's liability arising out of such information exceed the total purchase price of the TI part(s) at issue in this document sold by TI to Customer on an annual basis.

TAPE AND REEL INFORMATION

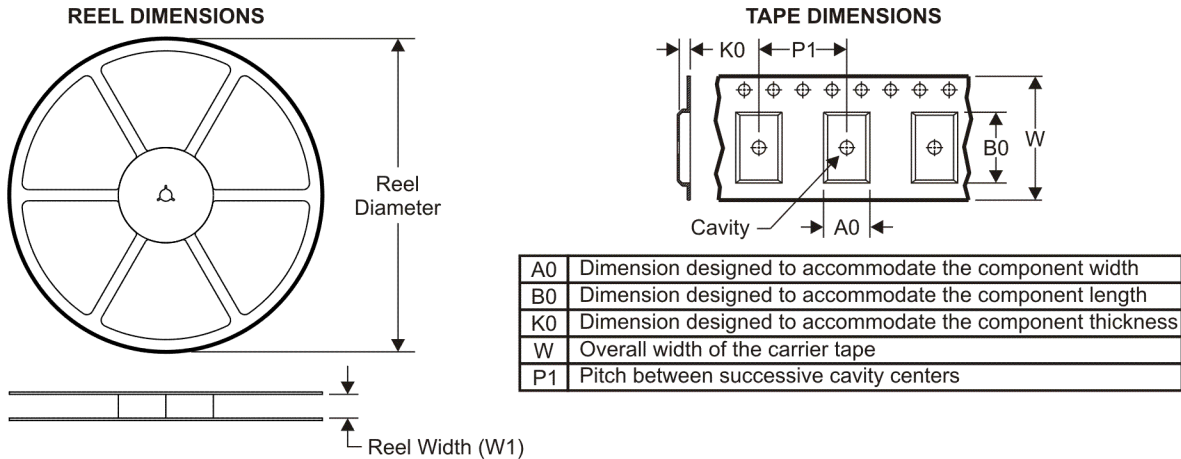

QUADRANT ASSIGNMENTS FOR PIN 1 ORIENTATION IN TAPE

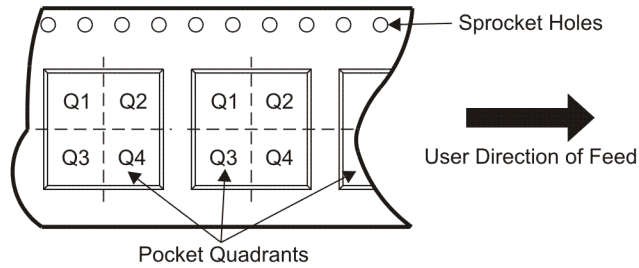

*All dimensions are nominal

Device	Package Type	Package Drawing	Pins	SPQ	Reel Diameter (mm)	Reel Width W1 (mm)	A0 (mm)	B0 (mm)	K0 (mm)	P1 (mm)	W (mm)	Pin1 Quadrant
SN65C23243DGGR	TSSOP	DGG	48	2000	330.0	24.4	8.6	15.8	1.8	12.0	24.0	Q1
SN65C23243DLR	SSOP	DL	48	1000	330.0	32.4	11.35	16.2	3.1	16.0	32.0	Q1
SN75C23243DGGR	TSSOP	DGG	48	2000	330.0	24.4	8.6	15.8	1.8	12.0	24.0	Q1
SN75C23243DLR	SSOP	DL	48	1000	330.0	32.4	11.35	16.2	3.1	16.0	32.0	Q1

TAPE AND REEL BOX DIMENSIONS

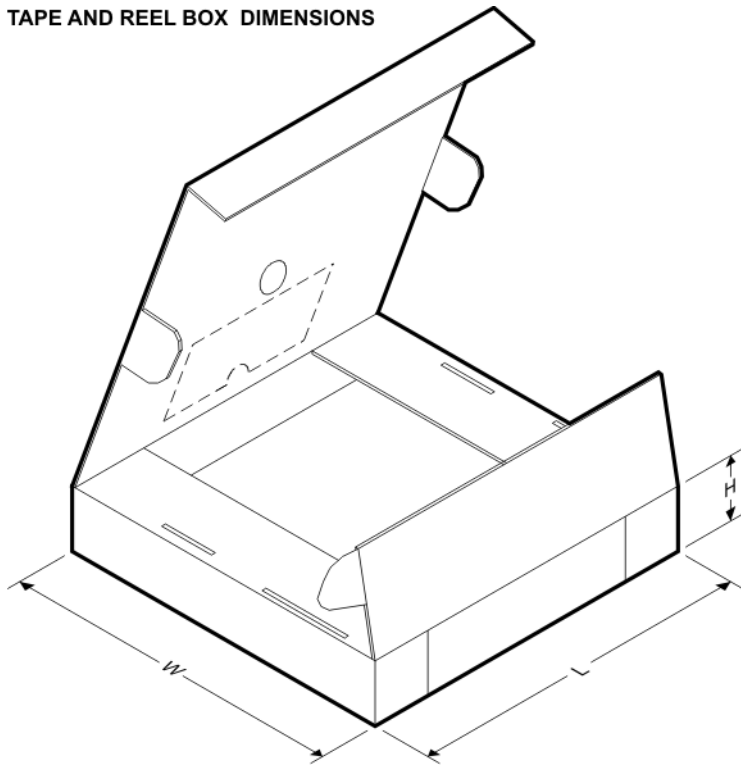

*All dimensions are nominal

Device	Package Type	Package Drawing	Pins	SPQ	Length (mm)	Width (mm)	Height (mm)
SN65C23243DGGR	TSSOP	DGG	48	2000	346.0	346.0	41.0
SN65C23243DLR	SSOP	DL	48	1000	346.0	346.0	49.0
SN75C23243DGGR	TSSOP	DGG	48	2000	346.0	346.0	41.0
SN75C23243DLR	SSOP	DL	48	1000	346.0	346.0	49.0

DL (R-PDSO-G**)

PLASTIC SMALL-OUTLINE PACKAGE

48 PINS SHOWN

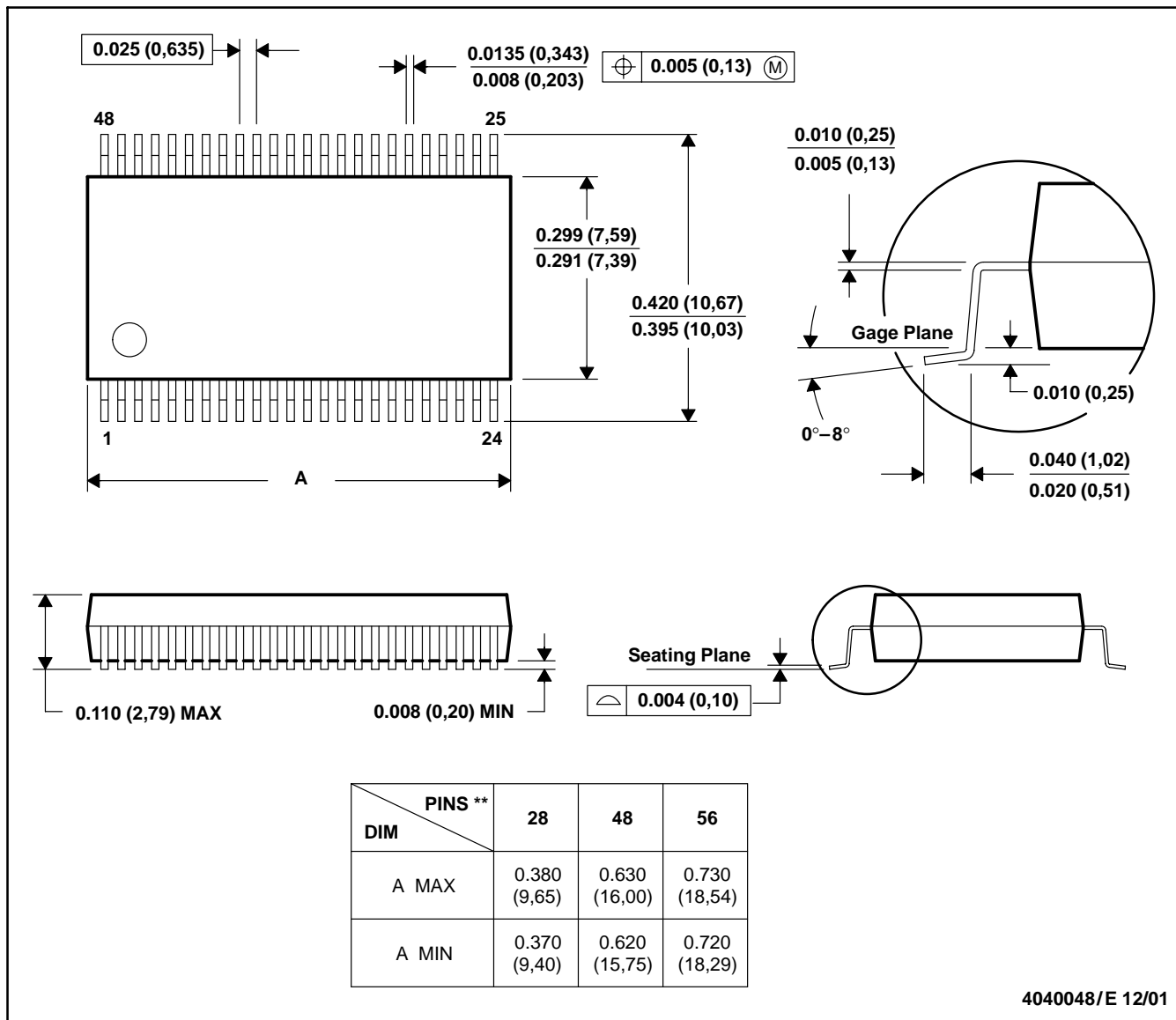

- NOTES: A. All linear dimensions are in inches (millimeters).
 B. This drawing is subject to change without notice.
 C. Body dimensions do not include mold flash or protrusion not to exceed 0.006 (0,15).
 D. Falls within JEDEC MO-118

DGG (R-PDSO-G**)

PLASTIC SMALL-OUTLINE PACKAGE

48 PINS SHOWN



- NOTES: A. All linear dimensions are in millimeters.
 B. This drawing is subject to change without notice.
 C. Body dimensions do not include mold protrusion not to exceed 0,15.
 D. Falls within JEDEC MO-153

IMPORTANT NOTICE

Texas Instruments Incorporated and its subsidiaries (TI) reserve the right to make corrections, modifications, enhancements, improvements, and other changes to its products and services at any time and to discontinue any product or service without notice. Customers should obtain the latest relevant information before placing orders and should verify that such information is current and complete. All products are sold subject to TI's terms and conditions of sale supplied at the time of order acknowledgment.

TI warrants performance of its hardware products to the specifications applicable at the time of sale in accordance with TI's standard warranty. Testing and other quality control techniques are used to the extent TI deems necessary to support this warranty. Except where mandated by government requirements, testing of all parameters of each product is not necessarily performed.

TI assumes no liability for applications assistance or customer product design. Customers are responsible for their products and applications using TI components. To minimize the risks associated with customer products and applications, customers should provide adequate design and operating safeguards.

TI does not warrant or represent that any license, either express or implied, is granted under any TI patent right, copyright, mask work right, or other TI intellectual property right relating to any combination, machine, or process in which TI products or services are used. Information published by TI regarding third-party products or services does not constitute a license from TI to use such products or services or a warranty or endorsement thereof. Use of such information may require a license from a third party under the patents or other intellectual property of the third party, or a license from TI under the patents or other intellectual property of TI.

Reproduction of TI information in TI data books or data sheets is permissible only if reproduction is without alteration and is accompanied by all associated warranties, conditions, limitations, and notices. Reproduction of this information with alteration is an unfair and deceptive business practice. TI is not responsible or liable for such altered documentation. Information of third parties may be subject to additional restrictions.

Resale of TI products or services with statements different from or beyond the parameters stated by TI for that product or service voids all express and any implied warranties for the associated TI product or service and is an unfair and deceptive business practice. TI is not responsible or liable for any such statements.

TI products are not authorized for use in safety-critical applications (such as life support) where a failure of the TI product would reasonably be expected to cause severe personal injury or death, unless officers of the parties have executed an agreement specifically governing such use. Buyers represent that they have all necessary expertise in the safety and regulatory ramifications of their applications, and acknowledge and agree that they are solely responsible for all legal, regulatory and safety-related requirements concerning their products and any use of TI products in such safety-critical applications, notwithstanding any applications-related information or support that may be provided by TI. Further, Buyers must fully indemnify TI and its representatives against any damages arising out of the use of TI products in such safety-critical applications.

TI products are neither designed nor intended for use in military/aerospace applications or environments unless the TI products are specifically designated by TI as military-grade or "enhanced plastic." Only products designated by TI as military-grade meet military specifications. Buyers acknowledge and agree that any such use of TI products which TI has not designated as military-grade is solely at the Buyer's risk, and that they are solely responsible for compliance with all legal and regulatory requirements in connection with such use.

TI products are neither designed nor intended for use in automotive applications or environments unless the specific TI products are designated by TI as compliant with ISO/TS 16949 requirements. Buyers acknowledge and agree that, if they use any non-designated products in automotive applications, TI will not be responsible for any failure to meet such requirements.

Following are URLs where you can obtain information on other Texas Instruments products and application solutions:

Products

Amplifiers	amplifier.ti.com
Data Converters	dataconverter.ti.com
DSP	dsp.ti.com
Clocks and Timers	www.ti.com/clocks
Interface	interface.ti.com
Logic	logic.ti.com
Power Mgmt	power.ti.com
Microcontrollers	microcontroller.ti.com
RFID	www.ti-rfid.com
RF/IF and ZigBee® Solutions	www.ti.com/lprf

Applications

Audio	www.ti.com/audio
Automotive	www.ti.com/automotive
Broadband	www.ti.com/broadband
Digital Control	www.ti.com/digitalcontrol
Medical	www.ti.com/medical
Military	www.ti.com/military
Optical Networking	www.ti.com/opticalnetwork
Security	www.ti.com/security
Telephony	www.ti.com/telephony
Video & Imaging	www.ti.com/video
Wireless	www.ti.com/wireless

Mailing Address: Texas Instruments, Post Office Box 655303, Dallas, Texas 75265
Copyright © 2008, Texas Instruments Incorporated

Looking for pricing, stock, or lifecycle information?

Click below to explore more details on WIN SOURCE:

 [View SN75C23243DLR on WIN SOURCE](#)

 [Texas Instruments](#) Information

Optimize Your Supply Chain with WIN SOURCE Solutions

-  Global Sourcing Solution
-  Obsolete Management
-  Cost Control Management
-  Shortage Management
-  Alternative Solution
-  Excess Inventory Management