



**THE DATASHEET OF  
TL780-12KCS**



## FEATURES

- $\pm 1\%$  Output Tolerance at 25°C
- $\pm 2\%$  Output Tolerance Over Full Operating Range
- Thermal Shutdown
- Internal Short-Circuit Current Limiting
- Pinout Identical to  $\mu A7800$  Series
- Improved Version of  $\mu A7800$  Series

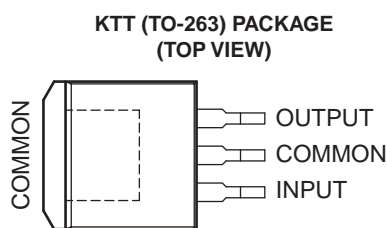
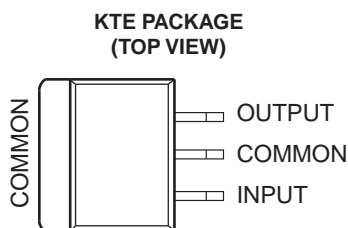
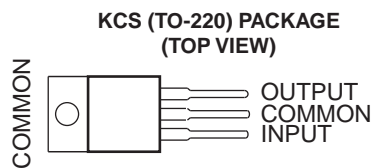
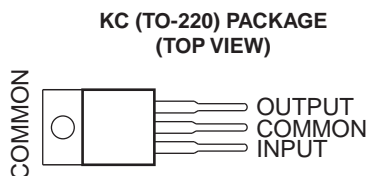

## DESCRIPTION/ORDERING INFORMATION

Each fixed-voltage precision regulator in the TL780 series is capable of supplying 1.5 A of load current. A unique temperature-compensation technique, coupled with an internally trimmed band-gap reference, has resulted in improved accuracy when compared to other three-terminal regulators. Advanced layout techniques provide excellent line, load, and thermal regulation. The internal current-limiting and thermal-shutdown features essentially make the devices immune to overload.

### ORDERING INFORMATION

| $T_J$        | $V_O$ TYP (V) | PACKAGE <sup>(1)</sup>       |              | ORDERABLE PART NUMBER | TOP-SIDE MARKING |
|--------------|---------------|------------------------------|--------------|-----------------------|------------------|
| 0°C to 125°C | 5             | PowerFLEX™ – KTE             | Reel of 2000 | TL780-05CKTER         | TL780-05C        |
|              |               | TO-220 – KC                  | Tube of 50   | TL780-05CKC           | TL780-05C        |
|              |               | TO-220, short shoulder – KCS | Tube of 20   | TL780-05KCS           | TL780-05         |
|              |               | TO-263 – KTT                 | Reel of 500  | TL780-05CKTTR         | TL780-05C        |
|              | 12            | TO-220 – KC                  | Tube of 50   | TL780-12CKC           | TL780-12C        |
|              |               | TO-220, short shoulder – KCS | Tube of 20   | TL780-12KCS           | TL780-12         |
|              | 15            | TO-220 – KC                  | Tube of 50   | TL780-15CKC           | TL780-15C        |
|              |               | TO-220, short shoulder – KCS | Tube of 20   | TL780-15KCS           | TL780-15         |

(1) Package drawings, standard packing quantities, thermal data, symbolization, and PCB design guidelines are available at [www.ti.com/sc/package](http://www.ti.com/sc/package).



Please be aware that an important notice concerning availability, standard warranty, and use in critical applications of Texas Instruments semiconductor products and disclaimers thereto appears at the end of this data sheet.

PowerFLEX, PowerPAD are trademarks of Texas Instruments.

**SCHEMATIC**

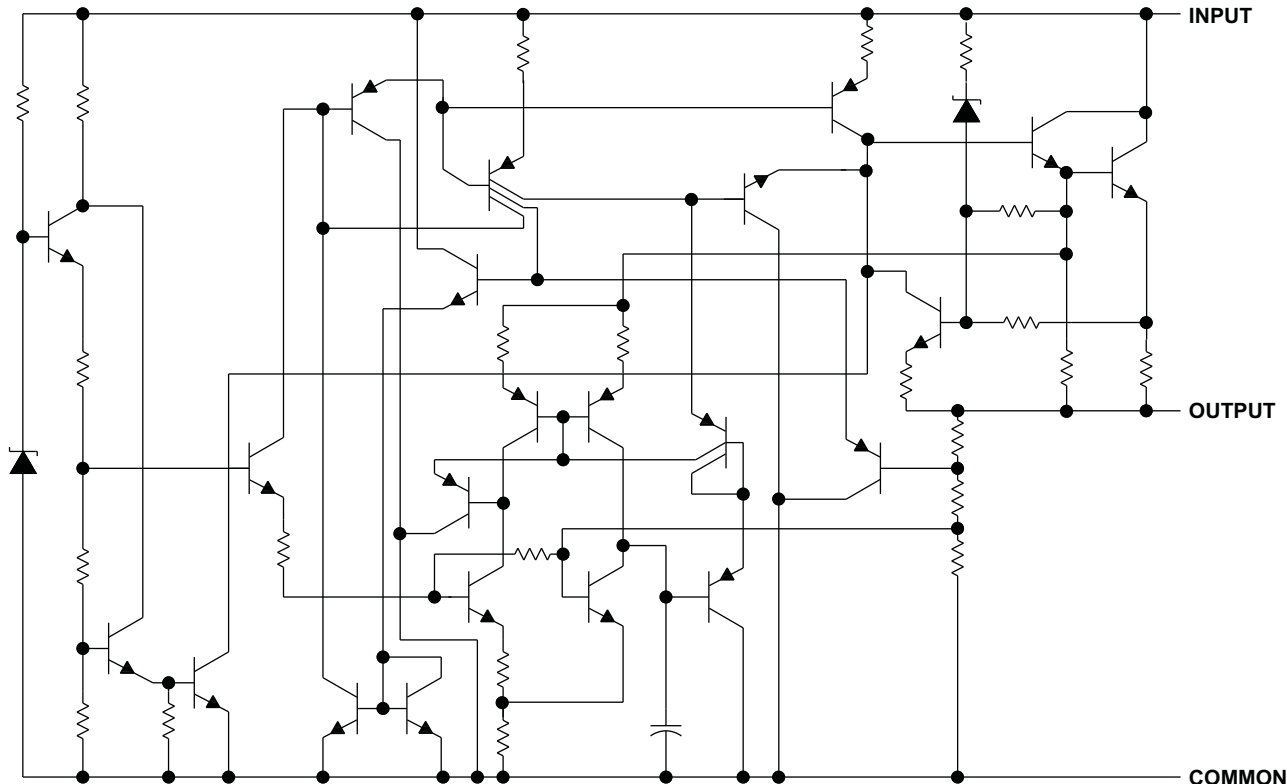

**Absolute Maximum Ratings<sup>(1)</sup>**

over operating temperature ranges (unless otherwise noted)

|           |  | MIN | MAX | UNIT |
|-----------|--|-----|-----|------|
| $V_I$     | Input voltage  |     | 35  | V    |
| $T_J$     | Operating virtual junction temperature               |     | 150 | °C   |
|           | Lead temperature 1,6 mm (1/16 in) from case for 10 s |     | 260 | °C   |
| $T_{stg}$ | Storage temperature range                            | -65 | 150 | °C   |

(1) Stresses beyond those listed under "absolute maximum ratings" may cause permanent damage to the device. These are stress ratings only, and functional operation of the device at these or any other conditions beyond those indicated under "recommended operating conditions" is not implied. Exposure to absolute-maximum-rated conditions for extended periods may affect device reliability.

**Package Thermal Data<sup>(1)</sup>**

| PACKAGE         | BOARD             | $\theta_{JP}$ <sup>(2)</sup> | $\theta_{JC}$ | $\theta_{JA}$ |
|-----------------|-------------------|------------------------------|---------------|---------------|
| PowerFLEX (KTE) | High K, JESD 51-5 | 2.7°C/W                      | 11.6°C/W      | 23.3°C/W      |
| TO-220 (KC/KCS) | High K, JESD 51-5 | 3°C/W                        | 17°C/W        | 19°C/W        |
| TO-263 (KTT)    | High K, JESD 51-5 | 1.91°C/W                     | 18°C/W        | 25.3°C/W      |

(1) Maximum power dissipation is a function of  $T_J(\max)$ ,  $\theta_{JA}$ , and  $T_A$ . The maximum allowable power dissipation at any allowable ambient temperature is  $P_D = (T_J(\max) - T_A)/\theta_{JA}$ . Operating at the absolute maximum  $T_J$  of 150°C can affect reliability. Due to variations in individual device electrical characteristics and thermal resistance, the built-in thermal overload protection may be activated at power levels slightly above or below the rated dissipation.

(2) For packages with exposed thermal pads, such as QFN, PowerPAD™, or PowerFLEX,  $\theta_{JP}$  is defined as the thermal resistance between the die junction and the bottom of the exposed pad.

**Recommended Operating Conditions**

|       |  |           | MIN  | MAX | UNIT |
|-------|--|-----------|------|-----|------|
| $V_I$ | Input voltage                          | TL780-05C | 7    | 25  | V    |
|       |  | TL780-12C | 14.5 | 30  |      |
|       |  | TL780-15C | 17.5 | 30  |      |
| $I_O$ | Output current                         |           | 1.5  | A   |      |
| $T_J$ | Operating virtual junction temperature |           | 0    | 125 | °C   |

**Electrical Characteristics**

 at specified virtual junction temperature,  $V_I = 10\text{ V}$ ,  $I_O = 500\text{ mA}$  (unless otherwise noted)

| PARAMETER                                 | TEST CONDITIONS   | $T_J$ (1)    | TL780-05C |     |      | UNIT          |    |
|---|---|--------------|-----------|-----|------|---------------|----|
|   |   |              | MIN       | TYP | MAX  |               |    |
| Output voltage                            | $I_O = 5\text{ mA to }1\text{ A}$ , $P \leq 15\text{ W}$ ,<br>$V_I = 7\text{ V to }20\text{ V}$ | 25°C         | 4.95      | 5   | 5.05 | V             |    |
|   |   | 0°C to 125°C | 4.9       |     | 5.1  |               |    |
| Input voltage regulation                  | $V_I = 7\text{ V to }25\text{ V}$   | 25°C         |           | 0.5 | 5    | mV            |    |
|   | $V_I = 8\text{ V to }12\text{ V}$   |              |           | 0.5 | 5    |               |    |
| Ripple rejection                          | $V_I = 8\text{ V to }18\text{ V}$ , $f = 120\text{ Hz}$   | 0°C to 125°C | 70        | 85  |      | dB            |    |
| Output voltage regulation                 | $I_O = 5\text{ mA to }1.5\text{ A}$   | 25°C         |           | 4   | 25   | mV            |    |
|   | $I_O = 250\text{ mA to }750\text{ mA}$  |              |           | 1.5 | 15   |               |    |
| Output resistance                         | $f = 1\text{ kHz}$  | 0°C to 125°C | 0.0035    |     |      | $\Omega$      |    |
| Temperature coefficient of output voltage | $I_O = 5\text{ mA}$   | 0°C to 125°C | 0.25      |     |      | mV/°C         |    |
| Output noise voltage                      | $f = 10\text{ Hz to }100\text{ kHz}$  | 25°C         | 75        |     |      | $\mu\text{V}$ |    |
| Dropout voltage                           | $I_O = 1\text{ A}$  | 25°C         | 2         |     |      | V             |    |
| Input bias current                        |   | 25°C         | 5         |     |      | 8             | mA |
| Input bias-current change                 | $V_I = 7\text{ V to }25\text{ V}$   | 0°C to 125°C | 0.7       |     |      | 1.3           | mA |
|   | $I_O = 5\text{ mA to }1\text{ A}$   |              | 0.003     |     |      | 0.5           |    |
| Short-circuit output current              |   | 25°C         | 750       |     |      | mA            |    |
| Peak output current                       |   | 25°C         | 2.2       |     |      | A             |    |

(1) Pulse-testing techniques maintain the junction temperature as close to the ambient temperature as possible. Thermal effects must be taken into account separately. All characteristics are measured with a 0.33- $\mu\text{F}$  capacitor across the input and a 0.22- $\mu\text{F}$  capacitor across the output.

# TL780 SERIES POSITIVE-VOLTAGE REGULATORS

SLVS055M – APRIL 1981 – REVISED OCTOBER 2006

## Electrical Characteristics

 at specified virtual junction temperature,  $V_I = 19\text{ V}$ ,  $I_O = 500\text{ mA}$  (unless otherwise noted)

| PARAMETER                                 | TEST CONDITIONS  | $T_J^{(1)}$  | TL780-12C |        |       | UNIT          |
|---|--|--------------|-----------|--------|-------|---------------|
|   |  |              | MIN       | TYP    | MAX   |               |
| Output voltage                            | $I_O = 5\text{ mA to }1\text{ A}$ , $P \leq 15\text{ W}$ ,<br>$V_I = 14.5\text{ V to }27\text{ V}$ | 25°C         | 11.88     | 12     | 12.12 | V             |
|   |  | 0°C to 125°C | 11.76     |        | 12.24 |               |
| Input voltage regulation                  | $V_I = 14.5\text{ V to }30\text{ V}$   | 25°C         |           | 1.2    | 12    | mV            |
|   | $V_I = 16\text{ V to }22\text{ V}$   |              |           | 1.2    | 12    |               |
| Ripple rejection                          | $V_I = 15\text{ V to }25\text{ V}$ , $f = 120\text{ Hz}$   | 0°C to 125°C | 65        | 80     |       | dB            |
| Output voltage regulation                 | $I_O = 5\text{ mA to }1.5\text{ A}$  | 25°C         |           | 6.5    | 60    | mV            |
|   | $I_O = 250\text{ mA to }750\text{ mA}$   |              |           | 2.5    | 36    |               |
| Output resistance                         | $f = 1\text{ kHz}$   | 0°C to 125°C |           | 0.0035 |       | $\Omega$      |
| Temperature coefficient of output voltage | $I_O = 5\text{ mA}$  | 0°C to 125°C |           | 0.6    |       | mV/°C         |
| Output noise voltage                      | $f = 10\text{ Hz to }100\text{ kHz}$   | 25°C         |           | 180    |       | $\mu\text{V}$ |
| Dropout voltage                           | $I_O = 1\text{ A}$   | 25°C         |           | 2      |       | V             |
| Input bias current                        |  | 25°C         |           | 5.5    | 8     | mA            |
| Input bias-current change                 | $V_I = 14.5\text{ V to }30\text{ V}$   | 0°C to 125°C |           | 0.4    | 1.3   | mA            |
|   | $I_O = 5\text{ mA to }1\text{ A}$  |              |           | 0.03   | 0.5   |               |
| Short-circuit output current              |  | 25°C         |           | 350    |       | mA            |
| Peak output current                       |  | 25°C         |           | 2.2    |       | A             |

(1) Pulse-testing techniques maintain the junction temperature as close to the ambient temperature as possible. Thermal effects must be taken into account separately. All characteristics are measured with a 0.33- $\mu\text{F}$  capacitor across the input and a 0.22- $\mu\text{F}$  capacitor across the output.

## Electrical Characteristics

 at specified virtual junction temperature,  $V_I = 23\text{ V}$ ,  $I_O = 500\text{ mA}$  (unless otherwise noted)

| PARAMETER                                 | TEST CONDITIONS  | $T_J^{(1)}$  | TL780-15C |        |       | UNIT          |
|---|--|--------------|-----------|--------|-------|---------------|
|   |  |              | MIN       | TYP    | MAX   |               |
| Output voltage                            | $I_O = 5\text{ mA to }1\text{ A}$ , $P \leq 15\text{ W}$ ,<br>$V_I = 17.5\text{ V to }30\text{ V}$ | 25°C         | 14.85     | 15     | 15.15 | V             |
|   |  | 0°C to 125°C | 14.7      |        | 15.3  |               |
| Input voltage regulation                  | $V_I = 17.5\text{ V to }30\text{ V}$   | 25°C         |           | 1.5    | 15    | mV            |
|   | $V_I = 20\text{ V to }26\text{ V}$   |              |           | 1.5    | 15    |               |
| Ripple rejection                          | $V_I = 18.5\text{ V to }28.5\text{ V}$ , $f = 120\text{ Hz}$                                       | 0°C to 125°C | 60        | 75     |       | dB            |
| Output voltage regulation                 | $I_O = 5\text{ mA to }1.5\text{ A}$  | 25°C         |           | 7      | 75    | mV            |
|   | $I_O = 250\text{ mA to }750\text{ mA}$   |              |           | 2.5    | 45    |               |
| Output resistance                         | $f = 1\text{ kHz}$   | 0°C to 125°C |           | 0.0035 |       | $\Omega$      |
| Temperature coefficient of output voltage | $I_O = 5\text{ mA}$  | 0°C to 125°C |           | 0.62   |       | mV/°C         |
| Output noise voltage                      | $f = 10\text{ Hz to }100\text{ kHz}$   | 25°C         |           | 225    |       | $\mu\text{V}$ |
| Dropout voltage                           | $I_O = 1\text{ A}$   | 25°C         |           | 2      |       | V             |
| Input bias current                        |  | 25°C         |           | 5.5    | 8     | mA            |
| Input bias-current change                 | $V_I = 17.5\text{ V to }30\text{ V}$   | 0°C to 125°C |           | 0.4    | 1.3   | mA            |
|   | $I_O = 5\text{ mA to }1\text{ A}$  |              |           | 0.02   | 0.5   |               |
| Short-circuit output current              |  | 25°C         |           | 230    |       | mA            |
| Peak output current                       |  | 25°C         |           | 2.2    |       | A             |

(1) Pulse-testing techniques maintain the junction temperature as close to the ambient temperature as possible. Thermal effects must be taken into account separately. All characteristics are measured with a 0.33- $\mu\text{F}$  capacitor across the input and a 0.22- $\mu\text{F}$  capacitor across the output.

### PARAMETER MEASUREMENT INFORMATION

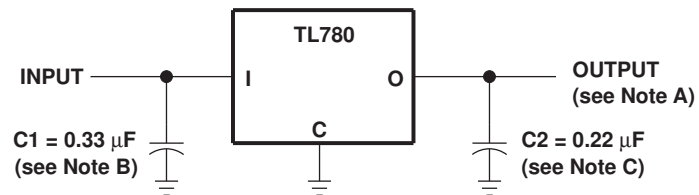

- A. Permanent damage can occur when OUTPUT is pulled below ground.
- B. C1 is required when the regulator is far from the power-supply filter.
- C. C2 is not required for stability; however, transient response is improved.

**Figure 1. Test Circuit**

**APPLICATION INFORMATION**

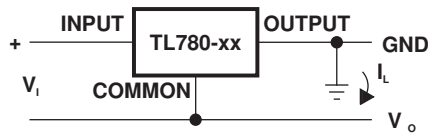

**Figure 2. Positive Regulator in Negative Configuration ( $V_i$  Must Float)**

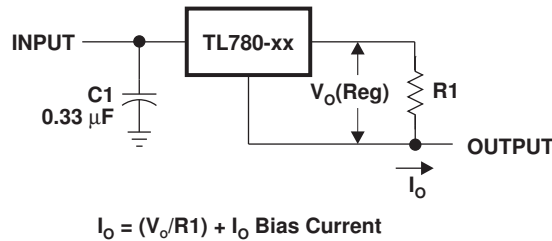

**Figure 3. Current Regulator**

**Operation With a Load Common to a Voltage of Opposite Polarity**

In many cases, a regulator powers a load that is not connected to ground, but instead, is connected to a voltage source of opposite polarity (e.g., operational amplifiers, level-shifting circuits, etc.). In these cases, a clamp diode should be connected to the regulator output as shown in [Figure 4](#). This protects the regulator from output polarity reversals during startup and short-circuit operation.

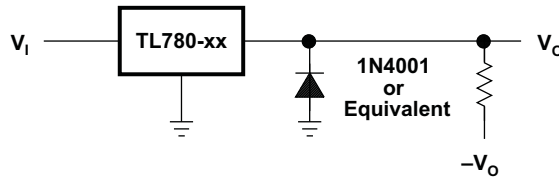

**Figure 4. Output Polarity-Reversal-Protection Circuit**

**Reverse-Bias Protection**

Occasionally, the input voltage to the regulator can collapse faster than the output voltage. This, for example, could occur when the input supply is crowbarred during an output overvoltage condition. If the output voltage is greater than approximately 7 V, the emitter-base junction of the series pass element (internal or external) could break down and be damaged. To prevent this, a diode shunt can be employed, as shown in [Figure 5](#).

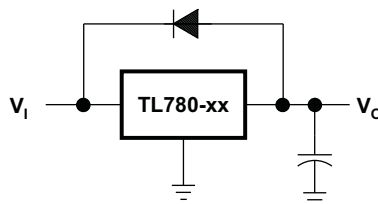

**Figure 5. Reverse-Bias-Protection Circuit**

**PACKAGING INFORMATION**

| Orderable Device | Status<br>(1) | Package Type     | Package Drawing | Pins | Package Qty | Eco Plan<br>(2)            | Lead/Ball Finish<br>(6) | MSL Peak Temp<br>(3) | Op Temp (°C) | Device Marking<br>(4/5) | Samples                 |
|------------------|---------------|------------------|-----------------|------|-------------|----------------------------|-------------------------|----------------------|--------------|-------------------------|-------------------------|
| TL780-05CKTTR    | ACTIVE        | DDPAK/<br>TO-263 | KTT             | 3    | 500         | Green (RoHS<br>& no Sb/Br) | CU SN                   | Level-3-245C-168 HR  | 0 to 125     | TL780-05C               | <a href="#">Samples</a> |
| TL780-05CKTTRG3  | ACTIVE        | DDPAK/<br>TO-263 | KTT             | 3    | 500         | Green (RoHS<br>& no Sb/Br) | CU SN                   | Level-3-245C-168 HR  | 0 to 125     | TL780-05C               | <a href="#">Samples</a> |
| TL780-05KCS      | ACTIVE        | TO-220           | KCS             | 3    | 50          | Pb-Free<br>(RoHS)          | CU SN                   | N / A for Pkg Type   | 0 to 125     | TL780-05                | <a href="#">Samples</a> |
| TL780-05KCSE3    | ACTIVE        | TO-220           | KCS             | 3    | 50          | Pb-Free<br>(RoHS)          | CU SN                   | N / A for Pkg Type   | 0 to 125     | TL780-05                | <a href="#">Samples</a> |
| TL780-12KCS      | ACTIVE        | TO-220           | KCS             | 3    | 50          | Pb-Free<br>(RoHS)          | CU SN                   | N / A for Pkg Type   | 0 to 125     | TL780-12                | <a href="#">Samples</a> |
| TL780-15KCS      | ACTIVE        | TO-220           | KCS             | 3    | 50          | Pb-Free<br>(RoHS)          | CU SN                   | N / A for Pkg Type   | 0 to 125     | TL780-15                | <a href="#">Samples</a> |
| TL780-15KCSE3    | ACTIVE        | TO-220           | KCS             | 3    | 50          | Pb-Free<br>(RoHS)          | CU SN                   | N / A for Pkg Type   | 0 to 125     | TL780-15                | <a href="#">Samples</a> |

(1) The marketing status values are defined as follows:

**ACTIVE:** Product device recommended for new designs.

**LIFEBUY:** TI has announced that the device will be discontinued, and a lifetime-buy period is in effect.

**NRND:** Not recommended for new designs. Device is in production to support existing customers, but TI does not recommend using this part in a new design.

**PREVIEW:** Device has been announced but is not in production. Samples may or may not be available.

**OBSOLETE:** TI has discontinued the production of the device.

(2) **RoHS:** TI defines "RoHS" to mean semiconductor products that are compliant with the current EU RoHS requirements for all 10 RoHS substances, including the requirement that RoHS substance do not exceed 0.1% by weight in homogeneous materials. Where designed to be soldered at high temperatures, "RoHS" products are suitable for use in specified lead-free processes. TI may reference these types of products as "Pb-Free".

**RoHS Exempt:** TI defines "RoHS Exempt" to mean products that contain lead but are compliant with EU RoHS pursuant to a specific EU RoHS exemption.

**Green:** TI defines "Green" to mean the content of Chlorine (Cl) and Bromine (Br) based flame retardants meet JS709B low halogen requirements of <=100ppm threshold. Antimony trioxide based flame retardants must also meet the <=1000ppm threshold requirement.

(3) MSL, Peak Temp. - The Moisture Sensitivity Level rating according to the JEDEC industry standard classifications, and peak solder temperature.

(4) There may be additional marking, which relates to the logo, the lot trace code information, or the environmental category on the device.

(5) Multiple Device Markings will be inside parentheses. Only one Device Marking contained in parentheses and separated by a "-" will appear on a device. If a line is indented then it is a continuation of the previous line and the two combined represent the entire Device Marking for that device.

<sup>(6)</sup> Lead/Ball Finish - Orderable Devices may have multiple material finish options. Finish options are separated by a vertical ruled line. Lead/Ball Finish values may wrap to two lines if the finish value exceeds the maximum column width.

**Important Information and Disclaimer:** The information provided on this page represents TI's knowledge and belief as of the date that it is provided. TI bases its knowledge and belief on information provided by third parties, and makes no representation or warranty as to the accuracy of such information. Efforts are underway to better integrate information from third parties. TI has taken and continues to take reasonable steps to provide representative and accurate information but may not have conducted destructive testing or chemical analysis on incoming materials and chemicals. TI and TI suppliers consider certain information to be proprietary, and thus CAS numbers and other limited information may not be available for release.

In no event shall TI's liability arising out of such information exceed the total purchase price of the TI part(s) at issue in this document sold by TI to Customer on an annual basis.

## TAPE AND REEL INFORMATION

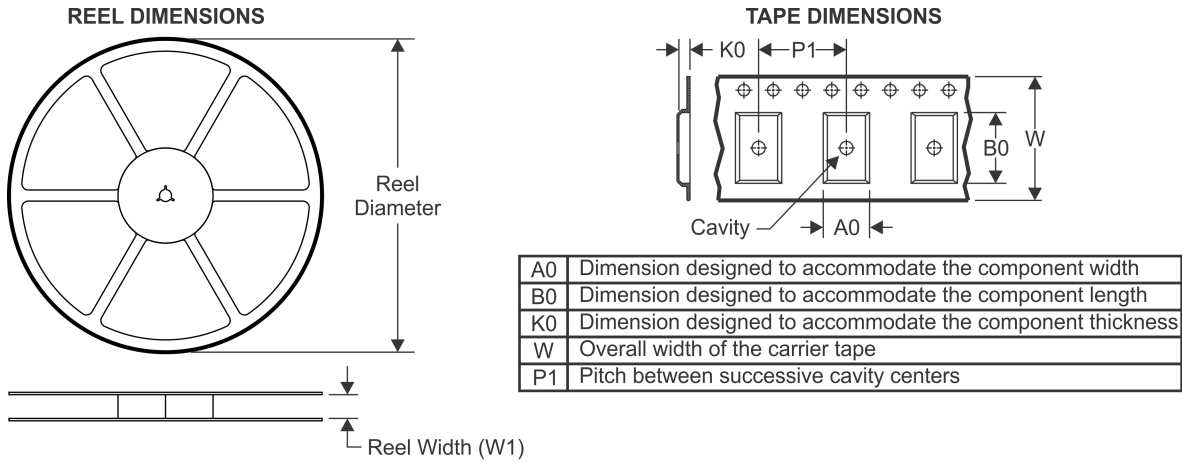

### QUADRANT ASSIGNMENTS FOR PIN 1 ORIENTATION IN TAPE

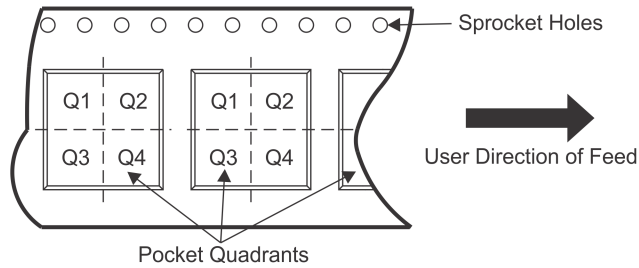

\*All dimensions are nominal

| Device        | Package Type     | Package Drawing | Pins | SPQ | Reel Diameter (mm) | Reel Width W1 (mm) | A0 (mm) | B0 (mm) | K0 (mm) | P1 (mm) | W (mm) | Pin1 Quadrant |
|---------------|------------------|-----------------|------|-----|--------------------|--------------------|---------|---------|---------|---------|--------|---------------|
| TL780-05CKTTR | DDPAK/<br>TO-263 | KTT             | 3    | 500 | 330.0              | 24.4               | 10.8    | 16.3    | 5.11    | 16.0    | 24.0   | Q2            |

**TAPE AND REEL BOX DIMENSIONS**



\*All dimensions are nominal

| Device        | Package Type | Package Drawing | Pins | SPQ | Length (mm) | Width (mm) | Height (mm) |
|---------------|--------------|-----------------|------|-----|-------------|------------|-------------|
| TL780-05CKTTR | DDPAK/TO-263 | KTT             | 3    | 500 | 340.0       | 340.0      | 38.0        |

KTT (R-PSFM-G3)

PLASTIC FLANGE-MOUNT PACKAGE

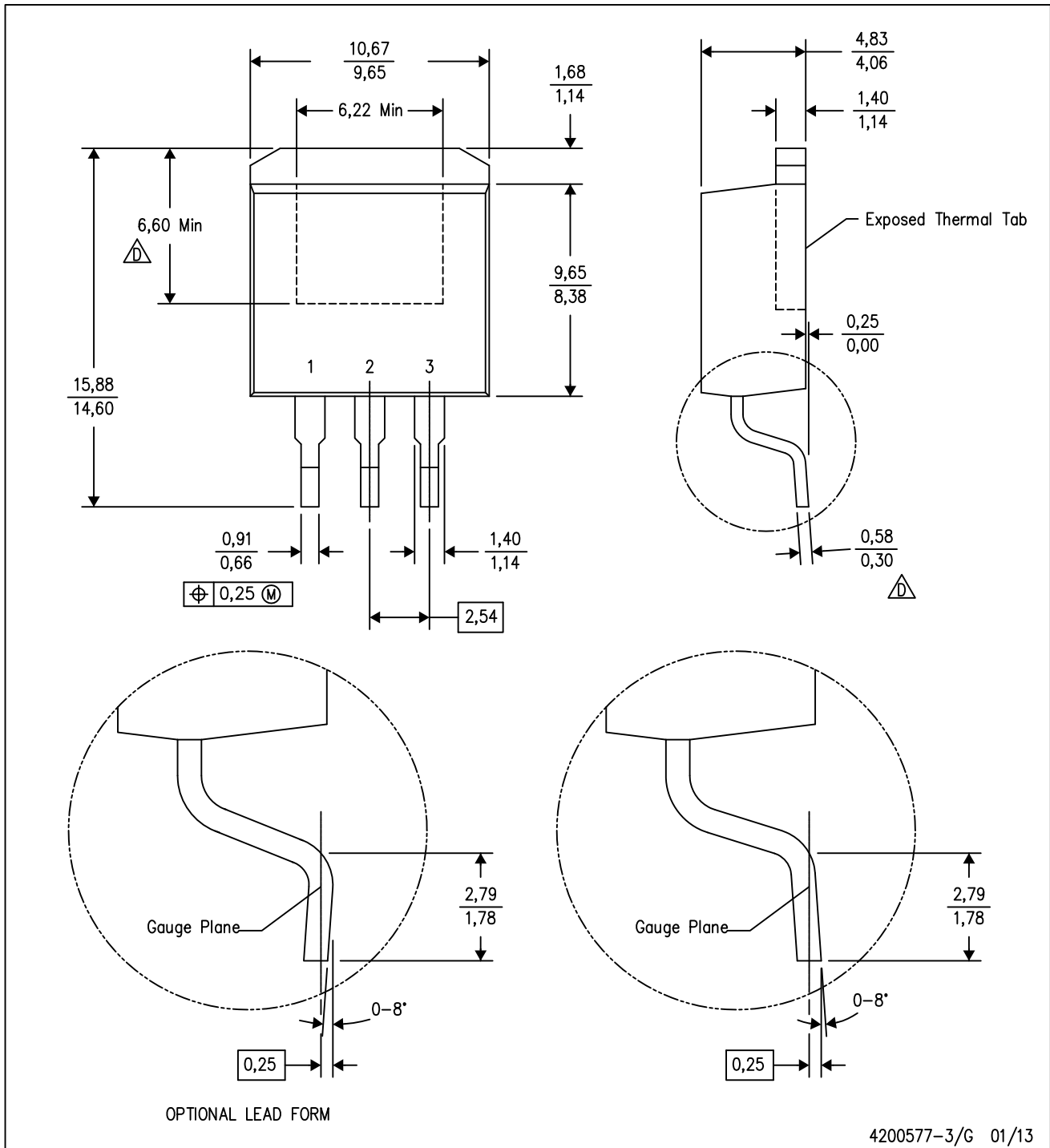

- NOTES:
- A. All linear dimensions are in millimeters.
  - B. This drawing is subject to change without notice.
  - C. Body dimensions do not include mold flash or protrusion. Mold flash or protrusion not to exceed 0.005 (0,13) per side.
- △ Falls within JEDEC TO-263 variation AA, except minimum lead thickness and minimum exposed pad length.

KTT (R-PSFM-G3)

PLASTIC FLANGE-MOUNT PACKAGE

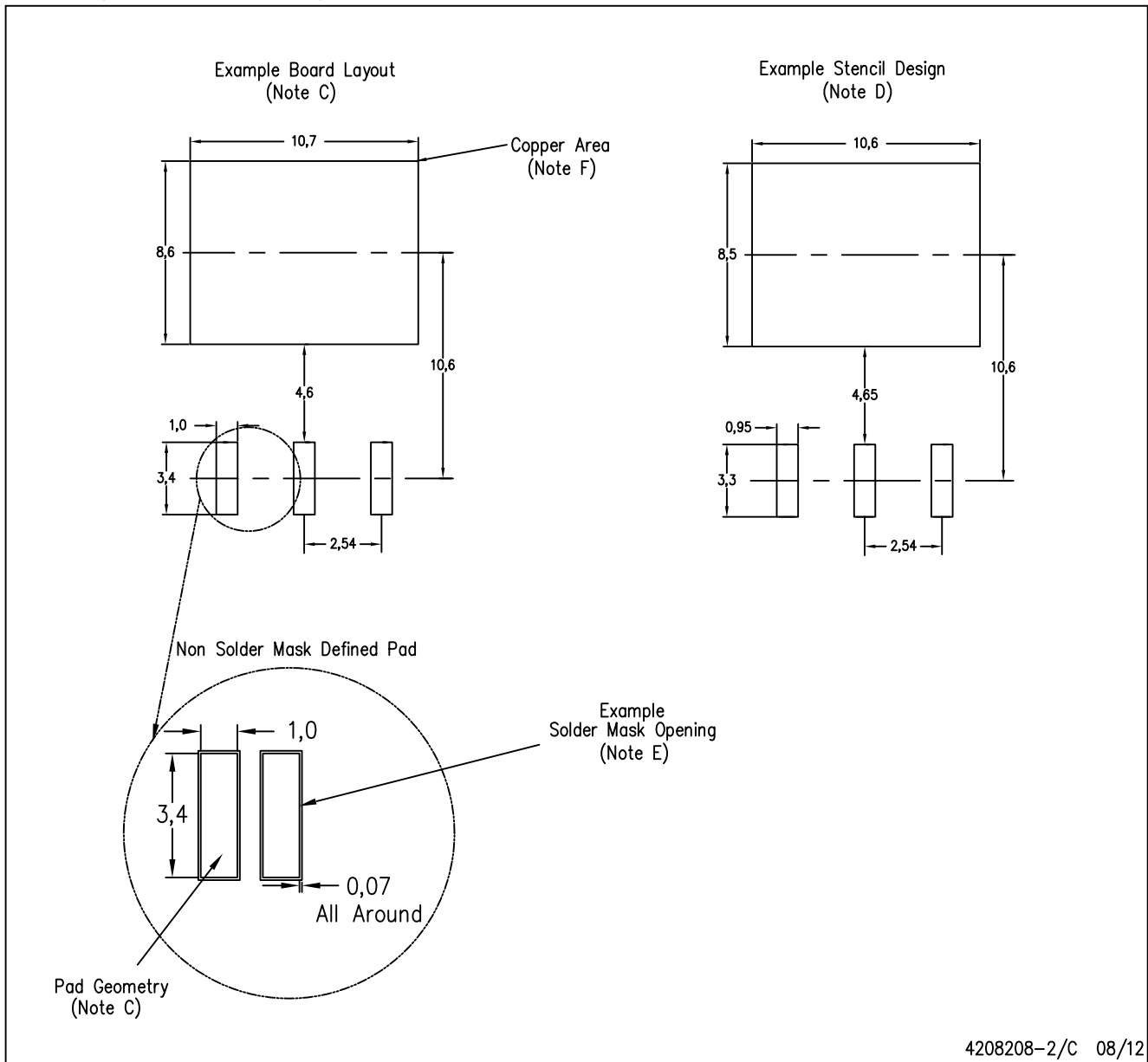

- NOTES:
- All linear dimensions are in millimeters.
  - This drawing is subject to change without notice.
  - Publication IPC-SM-782 is recommended for alternate designs.
  - Laser cutting apertures with trapezoidal walls and also rounding corners will offer better paste release. Customers should contact their board assembly site for stencil design recommendations. Refer to IPC-7525.
  - Customers should contact their board fabrication site for solder mask tolerances between and around signal pads.
  - This package is designed to be soldered to a thermal pad on the board. Refer to the Product Datasheet for specific thermal information, via requirements, and recommended thermal pad size. For thermal pad sizes larger than shown a solder mask defined pad is recommended in order to maintain the solderable pad geometry while increasing copper area.

# KCS0003B

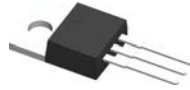

# PACKAGE OUTLINE

TO-220 - 19.65 mm max height

TO-220

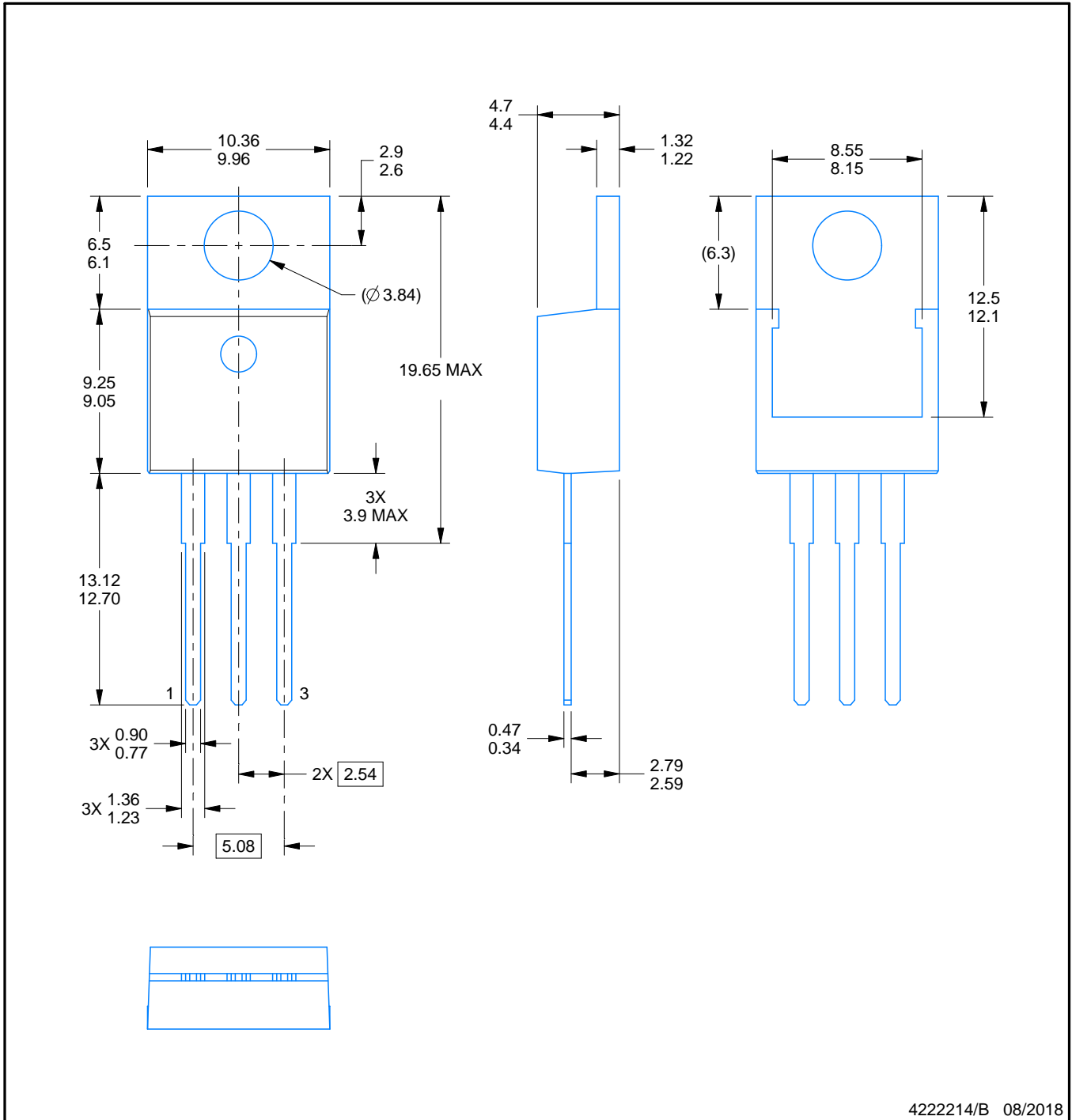

4222214/B 08/2018

## NOTES:

1. Dimensions are in millimeters. Any dimension in brackets or parenthesis are for reference only. Dimensioning and tolerancing per ASME Y14.5M.
2. This drawing is subject to change without notice.
3. Reference JEDEC registration TO-220.

# EXAMPLE BOARD LAYOUT

KCS0003B

TO-220 - 19.65 mm max height

TO-220

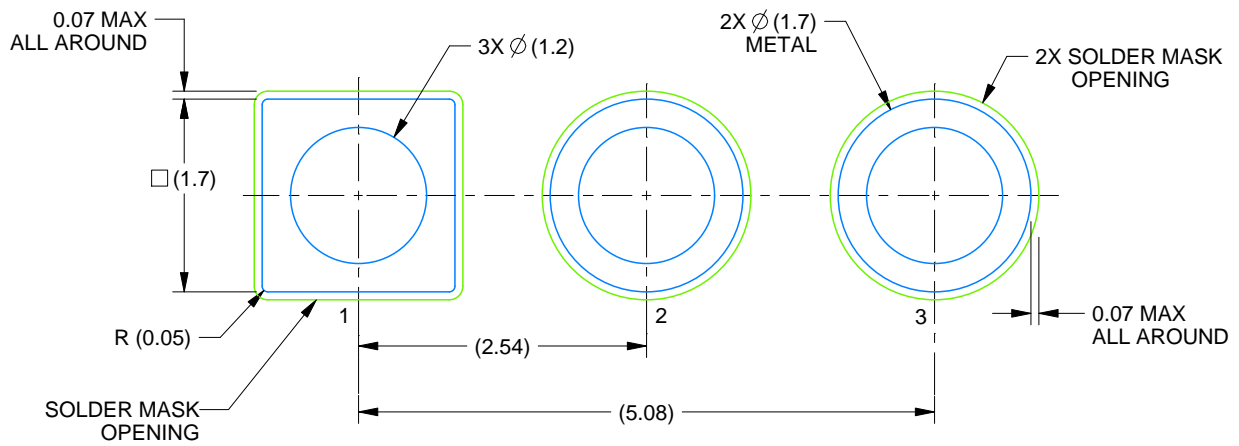

LAND PATTERN EXAMPLE  
NON-SOLDER MASK DEFINED  
SCALE:15X

4222214/B 08/2018

## IMPORTANT NOTICE AND DISCLAIMER

TI PROVIDES TECHNICAL AND RELIABILITY DATA (INCLUDING DATASHEETS), DESIGN RESOURCES (INCLUDING REFERENCE DESIGNS), APPLICATION OR OTHER DESIGN ADVICE, WEB TOOLS, SAFETY INFORMATION, AND OTHER RESOURCES "AS IS" AND WITH ALL FAULTS, AND DISCLAIMS ALL WARRANTIES, EXPRESS AND IMPLIED, INCLUDING WITHOUT LIMITATION ANY IMPLIED WARRANTIES OF MERCHANTABILITY, FITNESS FOR A PARTICULAR PURPOSE OR NON-INFRINGEMENT OF THIRD PARTY INTELLECTUAL PROPERTY RIGHTS.

These resources are intended for skilled developers designing with TI products. You are solely responsible for (1) selecting the appropriate TI products for your application, (2) designing, validating and testing your application, and (3) ensuring your application meets applicable standards, and any other safety, security, or other requirements. These resources are subject to change without notice. TI grants you permission to use these resources only for development of an application that uses the TI products described in the resource. Other reproduction and display of these resources is prohibited. No license is granted to any other TI intellectual property right or to any third party intellectual property right. TI disclaims responsibility for, and you will fully indemnify TI and its representatives against, any claims, damages, costs, losses, and liabilities arising out of your use of these resources.

TI's products are provided subject to TI's Terms of Sale ([www.ti.com/legal/termsofsale.html](http://www.ti.com/legal/termsofsale.html)) or other applicable terms available either on [ti.com](http://ti.com) or provided in conjunction with such TI products. TI's provision of these resources does not expand or otherwise alter TI's applicable warranties or warranty disclaimers for TI products.

Mailing Address: Texas Instruments, Post Office Box 655303, Dallas, Texas 75265  
Copyright © 2019, Texas Instruments Incorporated

## Looking for pricing, stock, or lifecycle information?

Click below to explore more details on WIN SOURCE:

 [View TL780-12KCS](#) on WIN SOURCE

 [Texas Instruments](#) Information

## Optimize Your Supply Chain with WIN SOURCE Solutions

-  Global Sourcing Solution
-  Obsolete Management
-  Cost Control Management
-  Shortage Management
-  Alternative Solution
-  Excess Inventory Management