

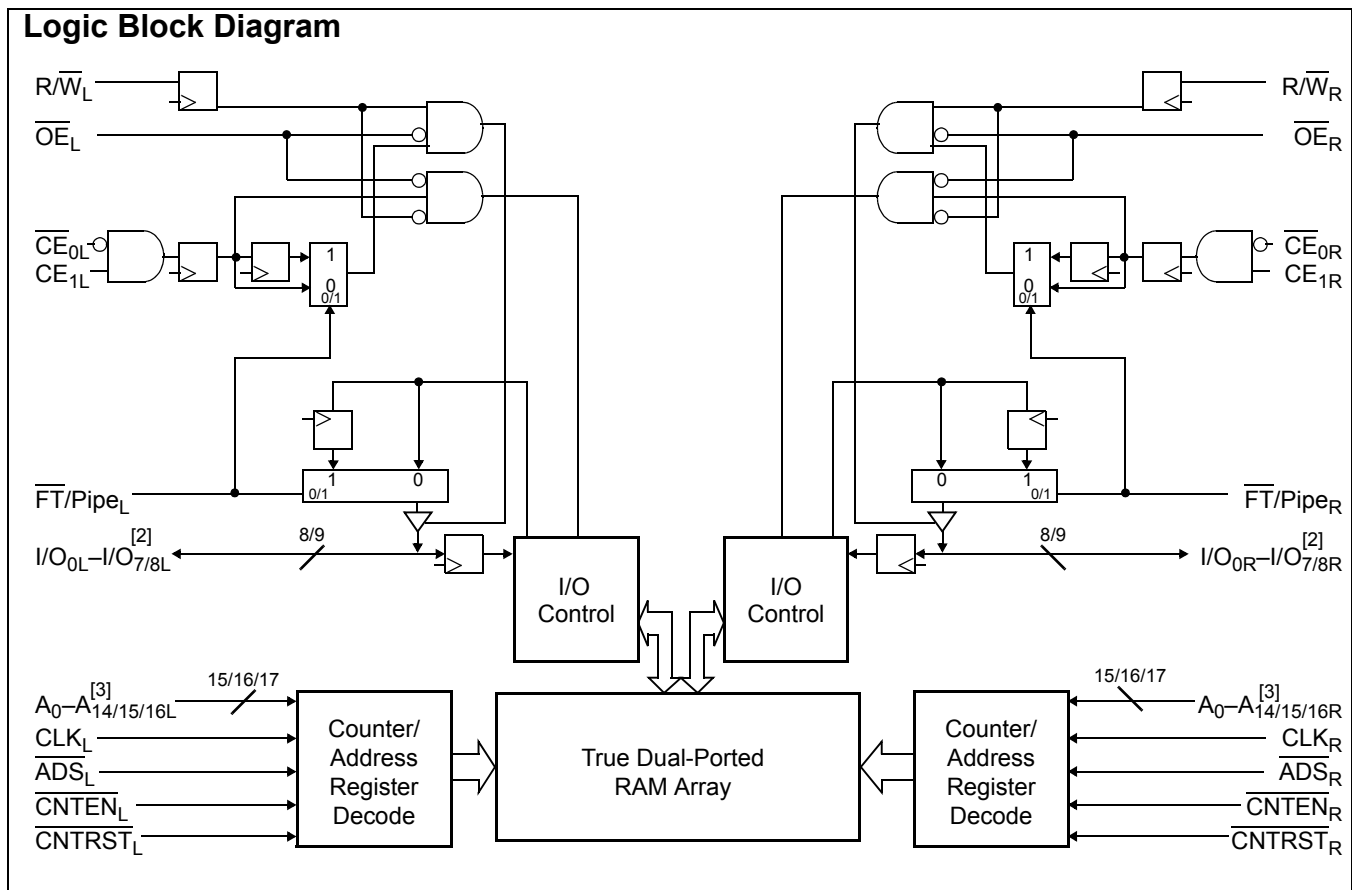

# 3.3V 32K/64K/128K x 8/9 Synchronous Dual-Port Static RAM

## Features

- True Dual-Ported memory cells which enable simultaneous access of the same memory location
- 6 Flow-Through and Pipelined devices
- 32K x 8/9 organizations (CY7C09079V/179V)
- 64K x 8/9 organizations (CY7C09089V/189V)
- 128K x 8/9 organizations (CY7C09099V/199V)
- 3 Modes
- Flow-Through
- Pipelined
- Burst
- Pipelined output mode on both ports enables fast 100 MHz operation
- 0.35-micron CMOS for optimum speed and power
- High speed clock to data access 6.5[1]/7.5[1]/9/12 ns (max.)
- 3.3V low operating power
- Active= 115 mA (typical)
- Standby= 10  $\mu$ A (typical)
- Fully synchronous interface for easier operation
- Burst counters increment addresses internally
- Shorten cycle times
- Minimize bus noise
- Supported in Flow-Through and Pipelined modes
- Dual Chip Enables for easy depth expansion
- Automatic power down
- Commercial and Industrial temperature ranges
- Available in 100-pin TQFP
- Pb-free packages available



- Notes**
1. See page 6 for Load Conditions.
  2. I/O<sub>0</sub>-I/O<sub>7</sub> for x8 devices, I/O<sub>0</sub>-I/O<sub>8</sub> for x9 devices.
  3. A<sub>0</sub>-A<sub>14</sub> for 32K, A<sub>0</sub>-A<sub>15</sub> for 64K, and A<sub>0</sub>-A<sub>16</sub> for 128K devices.

## Functional Description

The CY7C09079V/89V/99V and CY7C09179V/89V/99V are high speed synchronous CMOS 32K, 64K, and 128K x 8/9 dual-port static RAMs. Two ports are provided, permitting independent, simultaneous access for reads and writes to any location in memory.<sup>[4]</sup> Registers on control, address, and data lines enable minimal setup and hold times. In pipelined output mode, data is registered for decreased cycle time. Clock to data valid  $t_{CD2} = 6.5 \text{ ns}^{[1]}$  (pipelined). Flow-through mode can also be used to bypass the pipelined output register to eliminate access latency. In flow-through mode, data is available  $t_{CD1} = 18 \text{ ns}$  after the address is clocked into the device. Pipelined output or flow-through mode is selected via the FT/Pipe pin.

Each port contains a burst counter on the input address register. The internal write pulse width is independent of the LOW-to-HIGH transition of the clock signal. The internal write pulse is self-timed to enable the shortest possible cycle times.

A HIGH on  $\overline{CE}_0$  or LOW on  $CE_1$  for one clock cycle powers down the internal circuitry to reduce the static power consumption. The use of multiple Chip Enables enables easier banking of multiple chips for depth expansion configurations. In the pipelined mode, one cycle is required with  $\overline{CE}_0$  LOW and  $CE_1$  HIGH to reactivate the outputs.

Counter enable inputs are provided to stall the operation of the address input and use the internal address generated by the internal counter for fast interleaved memory applications. A port's burst counter is loaded with the port's Address Strobe (ADS). When the port's Count Enable (CNTEN) is asserted, the address counter increments on each LOW-to-HIGH transition of that port's clock signal. This reads/writes one word from/into each successive address location until CNTEN is deasserted. The counter can address the entire memory array and loops back to the start. Counter Reset (CNTRST) is used to reset the burst counter.

All parts are available in 100-pin Thin Quad Plastic Flatpack (TQFP) packages.

## Pin Configurations

Figure 1. 100-Pin TQFP (Top View) - CY7C09099V (128K x 8), CY7C09089V (64K x 8), CY7C09079V (32K x 8)

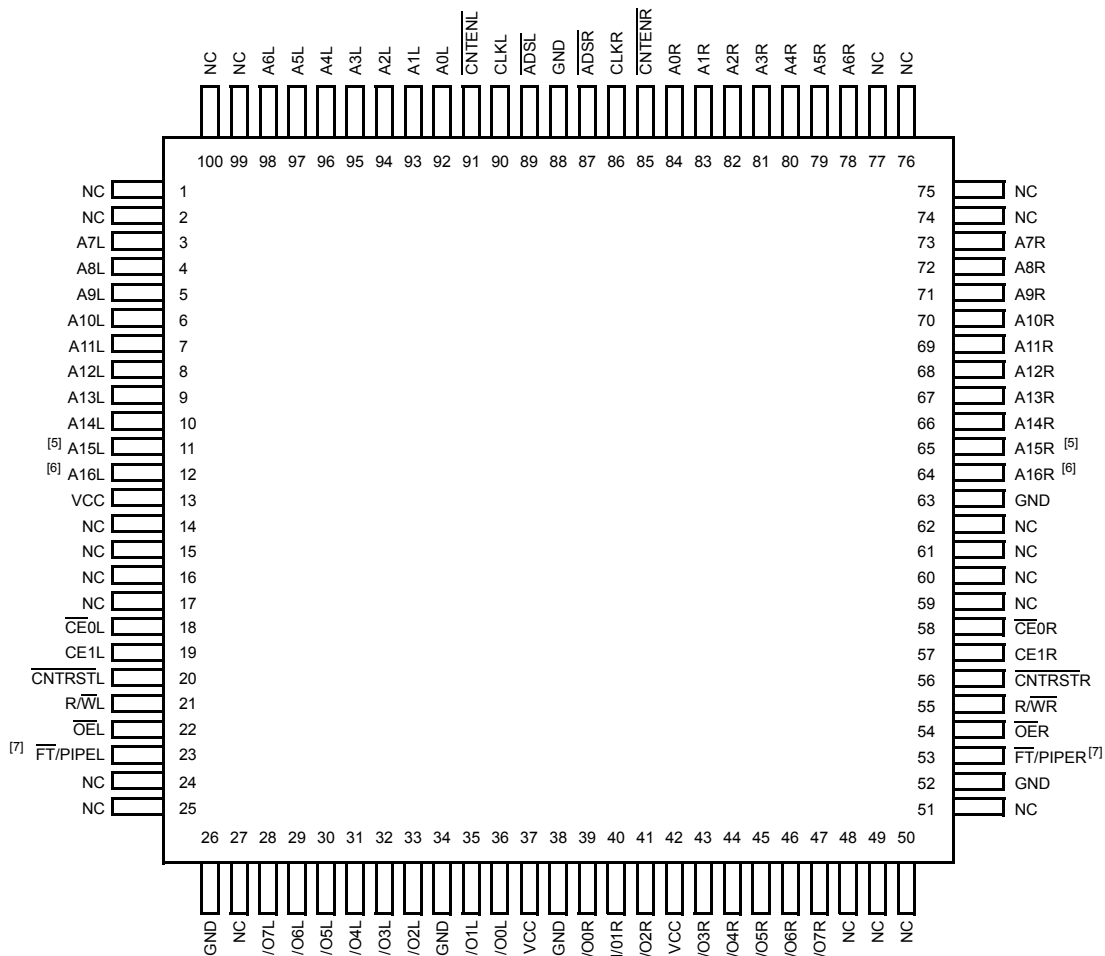

### Notes

- When writing simultaneously to the same location, the final value cannot be guaranteed.
- This pin is NC for CY7C09079V.
- This pin is NC for CY7C09079V and CY7C09089V.
- For CY7C09079V and CY7C09089V, pin #23 connected to V<sub>CC</sub> is pin compatible with an IDT 5V x8 pipelined device; connecting pin #23 and #53 to GND is pin compatible with an IDT 5V x16 flow-through device.

**Pin Configurations** (continued)

**Figure 2. 100-Pin TQFP (Top View0 - CY7C09199V (128K x 9), CY7C09189V (64K x 9),CY7C09179V (32K x 9)**

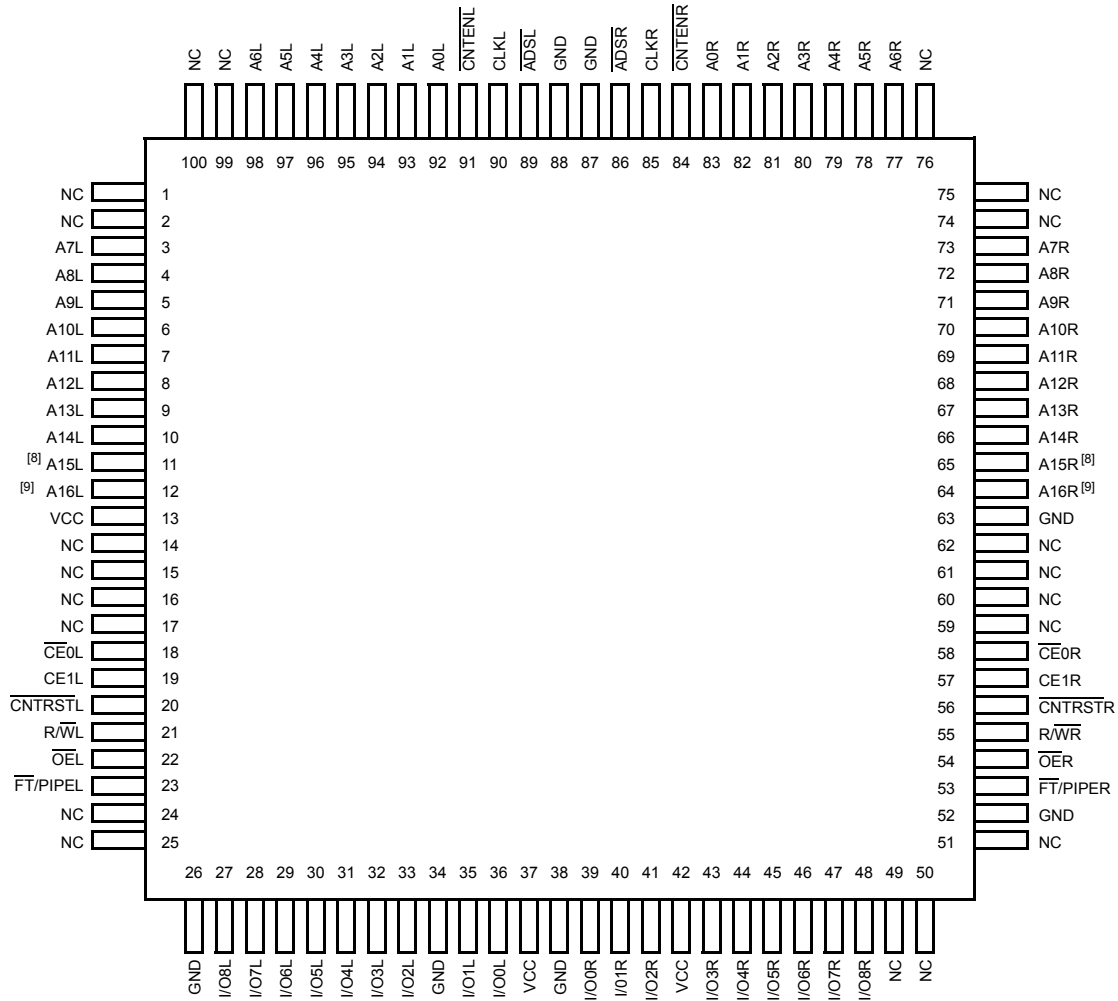

## Selection Guide

Description	CY7C09079V/89V/99V CY7C09179V/89V/99V-6 <sup>[1]</sup>	CY7C09079V/89V/99V CY7C09179V/89V/99V-7 <sup>[1]</sup>	CY7C09079V/89V/99V CY7C09179V/89V/99V -9	CY7C09079V/89V/99V CY7C09179V/89V/99V -12
f <sub>MAX2</sub> (MHz) (Pipelined)	100	83	67	50
Max. Access Time (ns) (Clock to Data, Pipelined)	6.5	7.5	9	12
Typical Operating Current I <sub>CC</sub> (mA)	175	155	135	115
Typical Standby Current for I <sub>SB1</sub> (mA) (Both Ports TTL Level)	25	25	20	20
Typical Standby Current for I <sub>SB3</sub> (μA) (Both Ports CMOS Level)	10 μA	10 μA	10 μA	10 μA

## Pin Definitions

Left Port	Right Port	Description
A <sub>0L</sub> -A <sub>16L</sub>	A <sub>0R</sub> -A <sub>16R</sub>	Address Inputs (A <sub>0</sub> -A <sub>14</sub> for 32K; A <sub>0</sub> -A <sub>15</sub> for 64K; and A <sub>0</sub> -A <sub>16</sub> for 128K devices).
ADS <sub>L</sub>	ADS <sub>R</sub>	Address Strobe Input. Used as an address qualifier. This signal should be asserted LOW to access the part using an externally supplied address. Asserting this signal LOW also loads the burst counter with the address present on the address pins.
$\overline{CE}_{0L}, CE_{1L}$	$\overline{CE}_{0R}, CE_{1R}$	Chip Enable Input. To select either the left or right port, both $\overline{CE}_0$ AND CE <sub>1</sub> must be asserted to their active states ( $\overline{CE}_0 \leq V_{IL}$ and CE <sub>1</sub> ≥ V <sub>IH</sub> ).
CLK <sub>L</sub>	CLK <sub>R</sub>	Clock Signal. This input can be free running or strobed. Maximum clock input rate is f <sub>MAX</sub> .
CNTEN <sub>L</sub>	CNTEN <sub>R</sub>	Counter Enable Input. Asserting this signal LOW increments the burst address counter of its respective port on each rising edge of CLK. CNTEN is disabled if ADS or CNTRST are asserted LOW.
CNTRST <sub>L</sub>	CNTRST <sub>R</sub>	Counter Reset Input. Asserting this signal LOW resets the burst address counter of its respective port to zero. CNTRST is not disabled by asserting ADS or CNTEN.
I/O <sub>0L</sub> -I/O <sub>8L</sub>	I/O <sub>0R</sub> -I/O <sub>8R</sub>	Data Bus Input/Output (I/O <sub>0</sub> -I/O <sub>7</sub> for x8 devices; I/O <sub>0</sub> -I/O <sub>8</sub> for x9 devices).
$\overline{OE}_L$	$\overline{OE}_R$	Output Enable Input. This signal must be asserted LOW to enable the I/O data pins during read operations.
R/ $\overline{W}$ <sub>L</sub>	R/ $\overline{W}$ <sub>R</sub>	Read/Write Enable Input. This signal is asserted LOW to write to the dual port memory array. For read operations, assert this pin HIGH.
$\overline{FT}/PIPE_L$	$\overline{FT}/PIPE_R$	Flow-Through/Pipelined Select Input. For flow-through mode operation, assert this pin LOW. For pipelined mode operation, assert this pin HIGH.
GND		Ground Input.
NC		No Connect.
V <sub>CC</sub>		Power Input.

### Notes

8. This pin is NC for CY7C09179V.
9. This pin is NC for CY7C09179V and CY7C09189V

## Maximum Ratings

Exceeding maximum ratings may impair the useful life of the device. These user guidelines are not tested.<sup>[10]</sup>

Storage Temperature ..... -65°C to +150°C  
 Ambient Temperature with Power Applied..-55°C to +125°C  
 Supply Voltage to Ground Potential.....-0.5V to +4.6V  
 DC Voltage Applied to  
 Outputs in High Z State .....-0.5V to V<sub>CC</sub>+0.5V  
 DC Input Voltage .....-0.5V to V<sub>CC</sub>+0.5V  
 Output Current into Outputs (LOW)..... 20 mA

Static Discharge Voltage..... >2001V  
 Latch-Up Current..... >200 mA

## Operating Range

Range	Ambient Temperature	V <sub>CC</sub>
Commercial	0°C to +70°C	3.3V ± 300 mV
Industrial <sup>[11]</sup>	-40°C to +85°C	3.3V ± 300 mV

## Electrical Characteristics Over the Operating Range

Parameter	Description	CY7C09079V/89V/99V CY7C09179V/89V/99V												Unit
		-6 <sup>[1]</sup>			-7 <sup>[1]</sup>			-9			-12			
		Min	Typ	Max	Min	Typ	Max	Min	Typ	Max	Min	Typ	Max	
V <sub>OH</sub>	Output HIGH Voltage (V <sub>CC</sub> = Min. I <sub>OH</sub> = -4.0 mA)	2.4			2.4			2.4			2.4			V
V <sub>OL</sub>	Output LOW Voltage (V <sub>CC</sub> = Min. I <sub>OH</sub> = +4.0 mA)			0.4			0.4			0.4			0.4	V
V <sub>IH</sub>	Input HIGH Voltage	2.0			2.0			2.0			2.0			V
V <sub>IL</sub>	Input LOW Voltage			0.8			0.8			0.8			0.8	V
I <sub>OZ</sub>	Output Leakage Current	-10		10	-10		10	-10		10	-10		10	μA
I <sub>CC</sub>	Operating Current (V <sub>CC</sub> = Max. I <sub>OUT</sub> = 0 mA) Outputs Disabled	Commercial.	175	320		155	275		135	225		115	205	mA
		Industrial <sup>[11]</sup>				275	390		185	295				mA
I <sub>SB1</sub>	Standby Current (Both Ports TTL Level) <sup>[12]</sup> CE <sub>L</sub> & CE <sub>R</sub> ≥ V <sub>IH</sub> , f = f <sub>MAX</sub>	Commercial.	25	95		25	85		20	65		20	50	mA
		Industrial <sup>[11]</sup>				85	120		35	75				mA
I <sub>SB2</sub>	Standby Current (One Port TTL Level) <sup>[12]</sup> CE <sub>L</sub>   CE <sub>R</sub> ≥ V <sub>IH</sub> , f = f <sub>MAX</sub>	Commercial.	115	175		105	165		95	150		85	140	mA
		Industrial <sup>[11]</sup>				165	210		105	160				mA
I <sub>SB3</sub>	Standby Current (Both Ports CMOS Level) <sup>[12]</sup> CE <sub>L</sub> & CE <sub>R</sub> ≥ V <sub>CC</sub> - 0.2V, f = 0	Commercial.	10	250		10	250		10	250		10	250	μA
		Industrial <sup>[11]</sup>				10	250		10	250				μA
I <sub>SB4</sub>	Standby Current (One Port CMOS Level) <sup>[12]</sup> CE <sub>L</sub>   CE <sub>R</sub> ≥ V <sub>IH</sub> , f = f <sub>MAX</sub>	Commercial	105	135		95	125		85	115		75	100	mA
		Industrial <sup>[11]</sup>				125	170		95	125				mA

## Capacitance

Parameter	Description	Test Conditions	Max	Unit
C <sub>IN</sub>	Input Capacitance	T <sub>A</sub> = 25°C, f = 1 MHz, V <sub>CC</sub> = 3.3V	10	pF
C <sub>OUT</sub>	Output Capacitance		10	pF

### Notes

10. The Voltage on any input or I/O pin cannot exceed the power pin during power-up.

11. Industrial parts are available in CY7C09099V and CY7C09199V only.

12. CE<sub>L</sub> and CE<sub>R</sub> are internal signals. To select either the left or right port, both CE<sub>0</sub> AND CE<sub>1</sub> must be asserted to their active states (CE<sub>0</sub> ≤ V<sub>IL</sub> and CE<sub>1</sub> ≥ V<sub>IH</sub>).

Figure 3. AC Test Loads

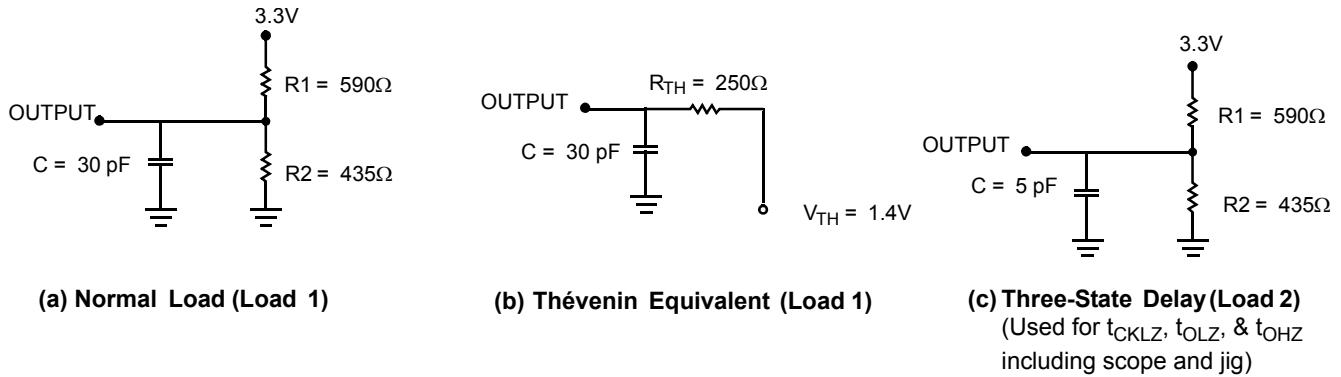

Figure 4. AC Test Loads (Applicable to -6 and -7 only)<sup>[13]</sup>

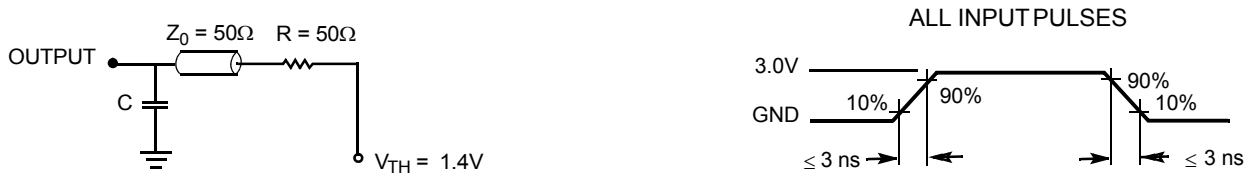
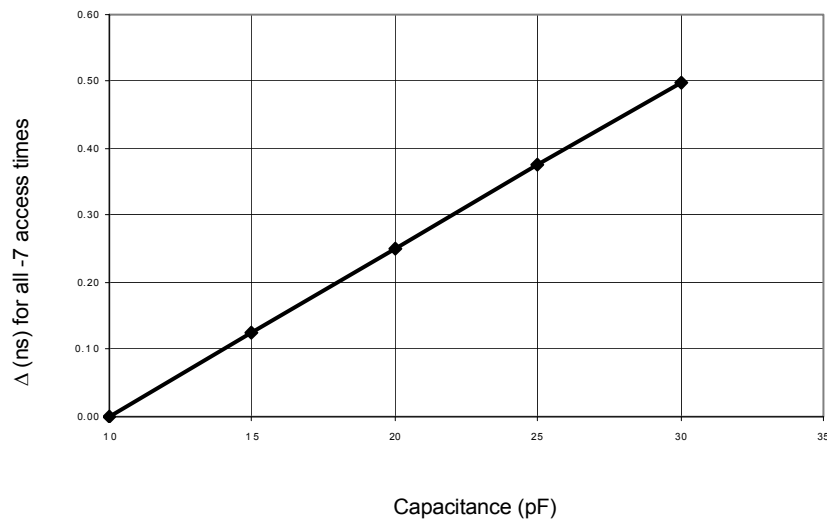

Figure 5. Load Derating Curve



**Note**  
13. Test Conditions: C = 10 pF.

**Switching Characteristics** Over the Operating Range

Parameter	Description	CY7C09079V/89V/99V CY7C09179V/89V/99V								Unit
		-6 <sup>[1]</sup>		-7 <sup>[1]</sup>		-9		-12		
		Min	Max	Min	Max	Min	Max	Min	Max	
f <sub>MAX1</sub>	f <sub>Max</sub> Flow-Through		53		45		40		33	MHz
f <sub>MAX2</sub>	f <sub>Max</sub> Pipelined		100		83		67		50	MHz
t <sub>CYC1</sub>	Clock Cycle Time - Flow-Through	19		22		25		30		ns
t <sub>CYC2</sub>	Clock Cycle Time - Pipelined	10		12		15		20		ns
t <sub>CH1</sub>	Clock HIGH Time - Flow-Through	6.5		7.5		12		12		ns
t <sub>CL1</sub>	Clock LOW Time - Flow-Through	6.5		7.5		12		12		ns
t <sub>CH2</sub>	Clock HIGH Time - Pipelined	4		5		6		8		ns
t <sub>CL2</sub>	Clock LOW Time - Pipelined	4		5		6		8		ns
t <sub>R</sub>	Clock Rise Time		3		3		3		3	ns
t <sub>F</sub>	Clock Fall Time		3		3		3		3	ns
t <sub>SA</sub>	Address Set-Up Time	3.5		4		4		4		ns
t <sub>HA</sub>	Address Hold Time	0		0		1		1		ns
t <sub>SC</sub>	Chip Enable Set-Up Time	3.5		4		4		4		ns
t <sub>HC</sub>	Chip Enable Hold Time	0		0		1		1		ns
t <sub>SW</sub>	R/W Set-Up Time	3.5		4		4		4		ns
t <sub>HW</sub>	R/W Hold Time	0		0		1		1		ns
t <sub>SD</sub>	Input Data Set-Up Time	3.5		4		4		4		ns
t <sub>HD</sub>	Input Data Hold Time	0		0		1		1		ns
t <sub>SAD</sub>	ADS Set-Up Time	3.5		4		4		4		ns
t <sub>HAD</sub>	ADS Hold Time	0		0		1		1		ns
t <sub>SCN</sub>	CNTEN Set-Up Time	3.5		4.5		5		5		ns
t <sub>HCN</sub>	CNTEN Hold Time	0		0		1		1		ns
t <sub>SRST</sub>	CNTRST Set-Up Time	3.5		4		4		4		ns
t <sub>HRST</sub>	CNTRST Hold Time	0		0		1		1		ns
t <sub>OE</sub>	Output Enable to Data Valid		8		9		10		12	ns
t <sub>OLZ</sub> <sup>[14, 15]</sup>	OE to Low Z	2		2		2		2		ns
t <sub>OHZ</sub> <sup>[14, 15]</sup>	OE to High Z	1	7	1	7	1	7	1	7	ns
t <sub>CD1</sub>	Clock to Data Valid - Flow-Through		15		18		20		25	ns
t <sub>CD2</sub>	Clock to Data Valid - Pipelined		6.5		7.5		9		12	ns
t <sub>DC</sub>	Data Output Hold After Clock HIGH	2		2		2		2		ns
t <sub>CKHZ</sub> <sup>[14, 15]</sup>	Clock HIGH to Output High Z	2	9	2	9	2	9	2	9	ns
t <sub>CKLZ</sub> <sup>[14, 15]</sup>	Clock HIGH to Output Low Z	2		2		2		2		ns
<b>Port to Port Delays</b>										
t <sub>CWDD</sub>	Write Port Clock HIGH to Read Data Delay		30		35		40		40	ns
t <sub>CCS</sub>	Clock to Clock Set-Up Time		9		10		15		15	ns

**Notes**

14. Test conditions used are Load 2.

15. This parameter is guaranteed by design, but it is not production tested.

Switching Waveforms (continued)

Figure 6. Read Cycle for Flow-Through Output ( $\overline{\text{FT}}/\text{PIPE} = V_{\text{IL}}$ )<sup>[16, 17, 18, 19]</sup>

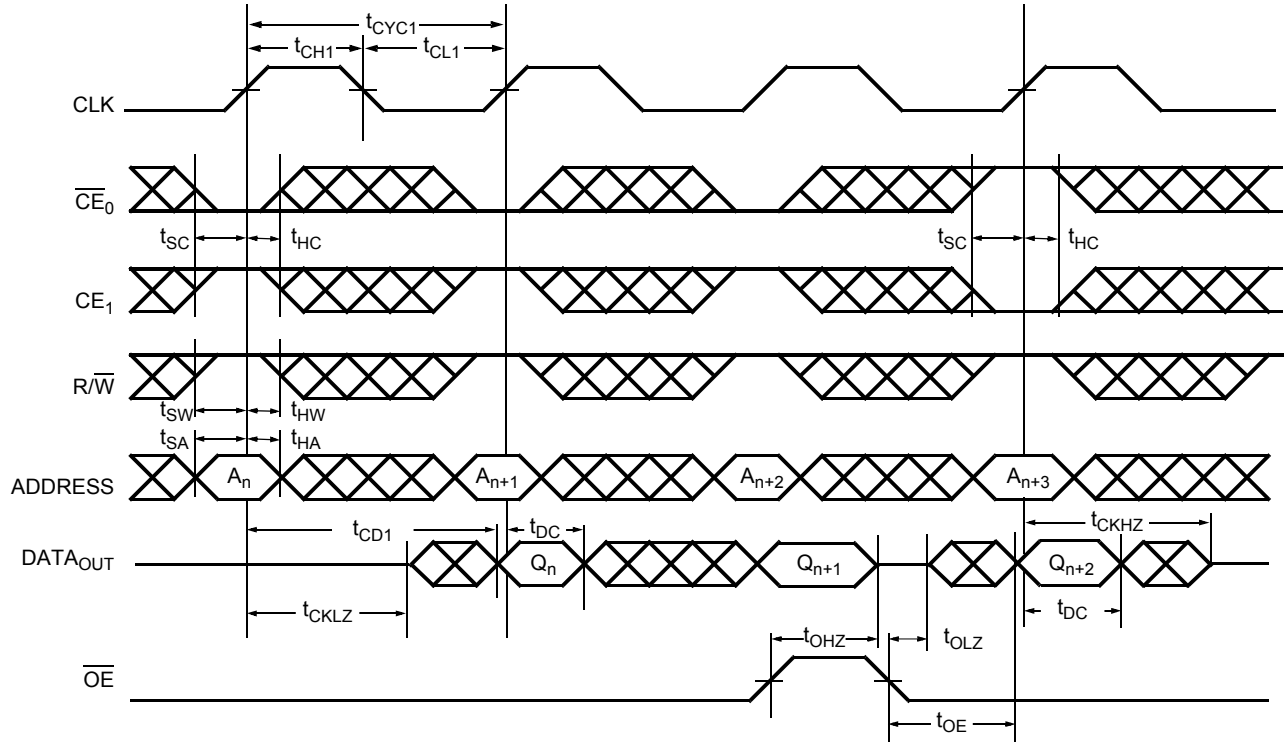

Notes

16.  $\overline{\text{OE}}$  is asynchronously controlled; all other inputs are synchronous to the rising clock edge.
17.  $\text{ADS} = V_{\text{IL}}$ ,  $\overline{\text{CNTEN}}$  and  $\overline{\text{CNTRST}} = V_{\text{IH}}$ .
18. The output is disabled (high-impedance state) by  $\overline{\text{CE}}_0 = V_{\text{IH}}$  or  $\text{CE}_1 = V_{\text{IL}}$  following the next rising edge of the clock.
19. Addresses do not have to be accessed sequentially since  $\text{ADS} = V_{\text{IL}}$  constantly loads the address on the rising edge of the CLK. Numbers are for reference only.

Switching Waveforms (continued)

Figure 7. Read Cycle for Pipelined Operation ( $\overline{FT}/PIPE = V_{IH}$ )<sup>[16, 17, 18, 19]</sup>

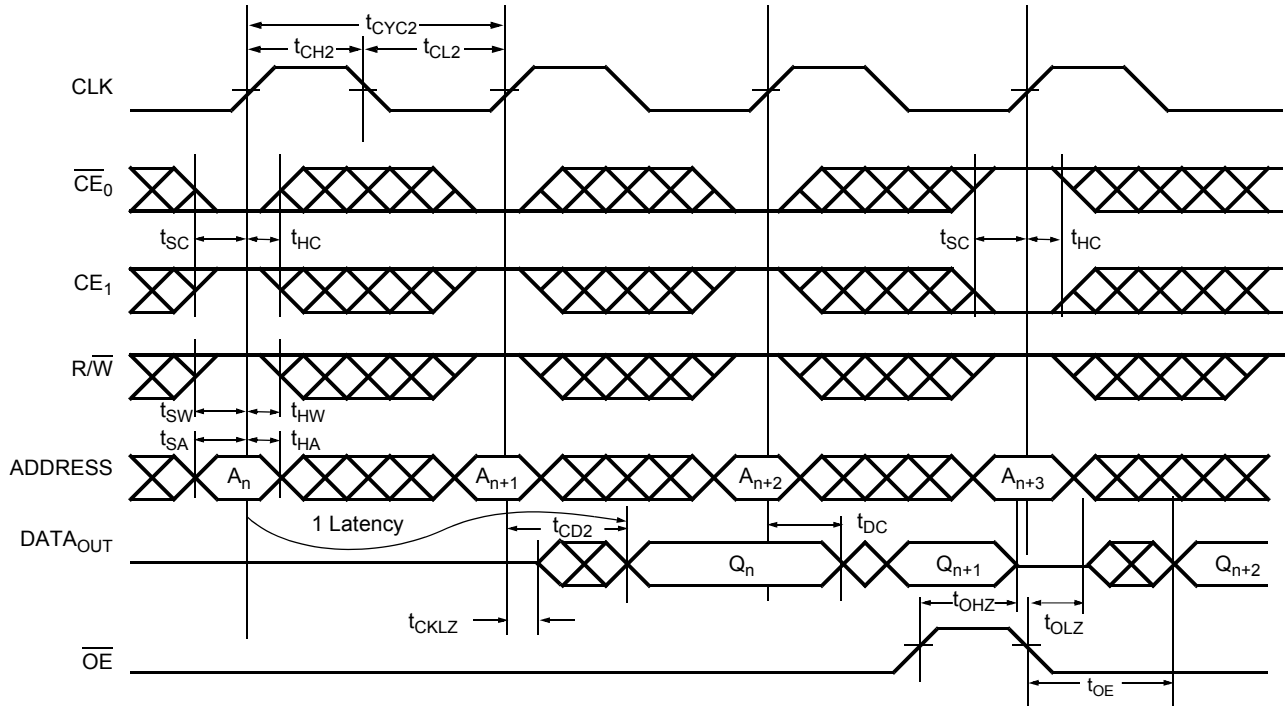
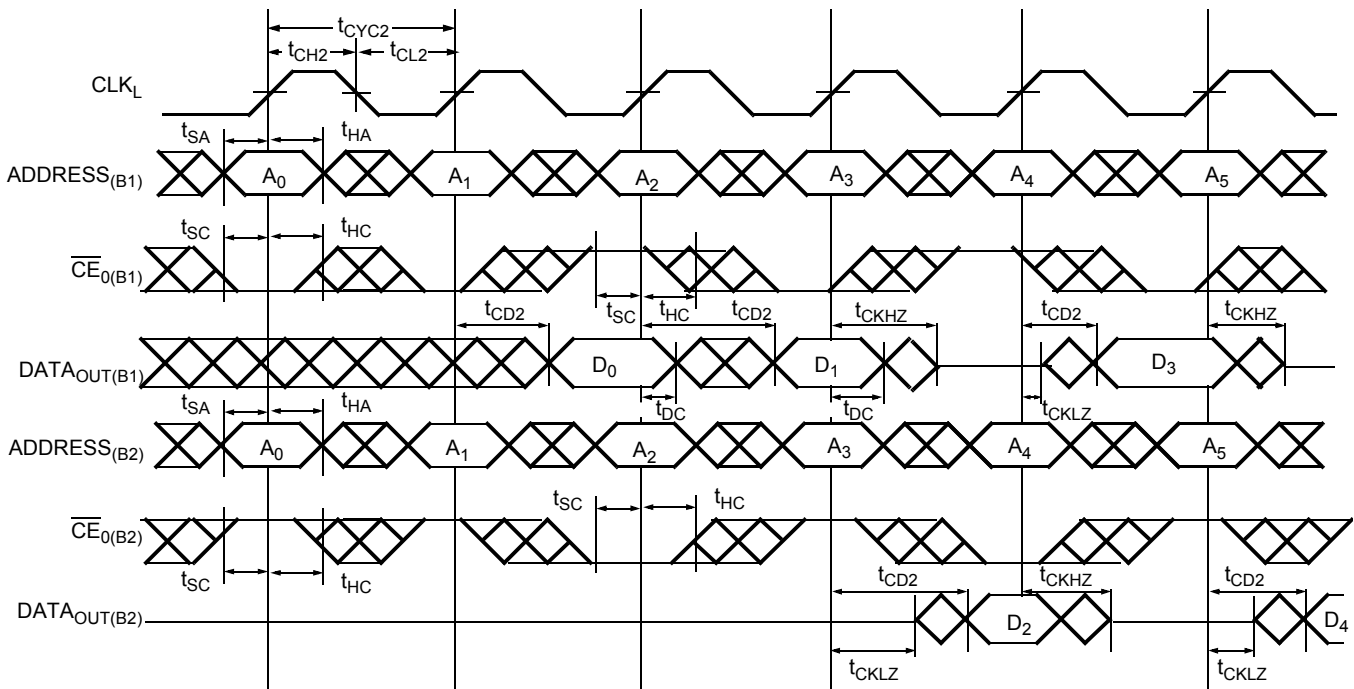
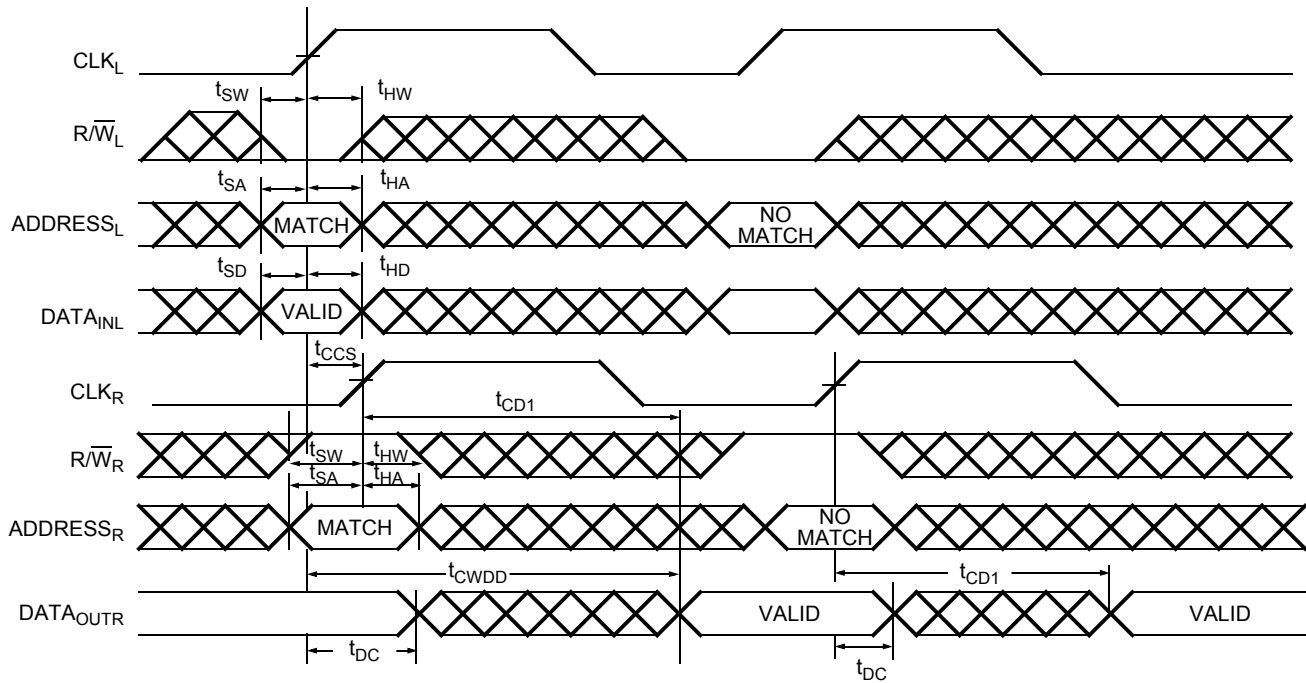

Figure 8. Bank Select Pipelined Read<sup>[20, 21]</sup>



**Switching Waveforms** (continued)

**Figure 9. Left Port Write to Flow-Through Right Port Read**<sup>[22, 23, 24, 25]</sup>



**Notes**

20. In this depth expansion example, B1 represents Bank #1 and B2 is Bank #2; Each Bank consists of one Cypress dual-port device from this datasheet. ADDRESS<sub>(B1)</sub> = ADDRESS<sub>(B2)</sub>.
21. OE and ADS = V<sub>IL</sub>; CE<sub>1(B1)</sub>, CE<sub>1(B2)</sub>, R/W, CNTEN, and CNTRST = V<sub>IH</sub>.
22. The same waveforms apply for a right port write to flow-through left port read.
23. CE<sub>0</sub> and ADS = V<sub>IL</sub>; CE<sub>1</sub>, CNTEN, and CNTRST = V<sub>IH</sub>.
24. OE = V<sub>IL</sub> for the right port, which is being read from. OE = V<sub>IH</sub> for the left port, which is being written to.
25. If t<sub>CCS</sub> ≤ maximum specified, then data from right port READ is not valid until the maximum specified for t<sub>CWDD</sub>. If t<sub>CCS</sub> > maximum specified, then data is not valid until t<sub>CCS</sub> + t<sub>CD1</sub>. t<sub>CWDD</sub> does not apply in this case.

Switching Waveforms (continued)

Figure 10. Pipelined Read-to-Write-to-Read ( $\overline{OE} = V_{IL}$ )<sup>[19, 26, 27, 28]</sup>

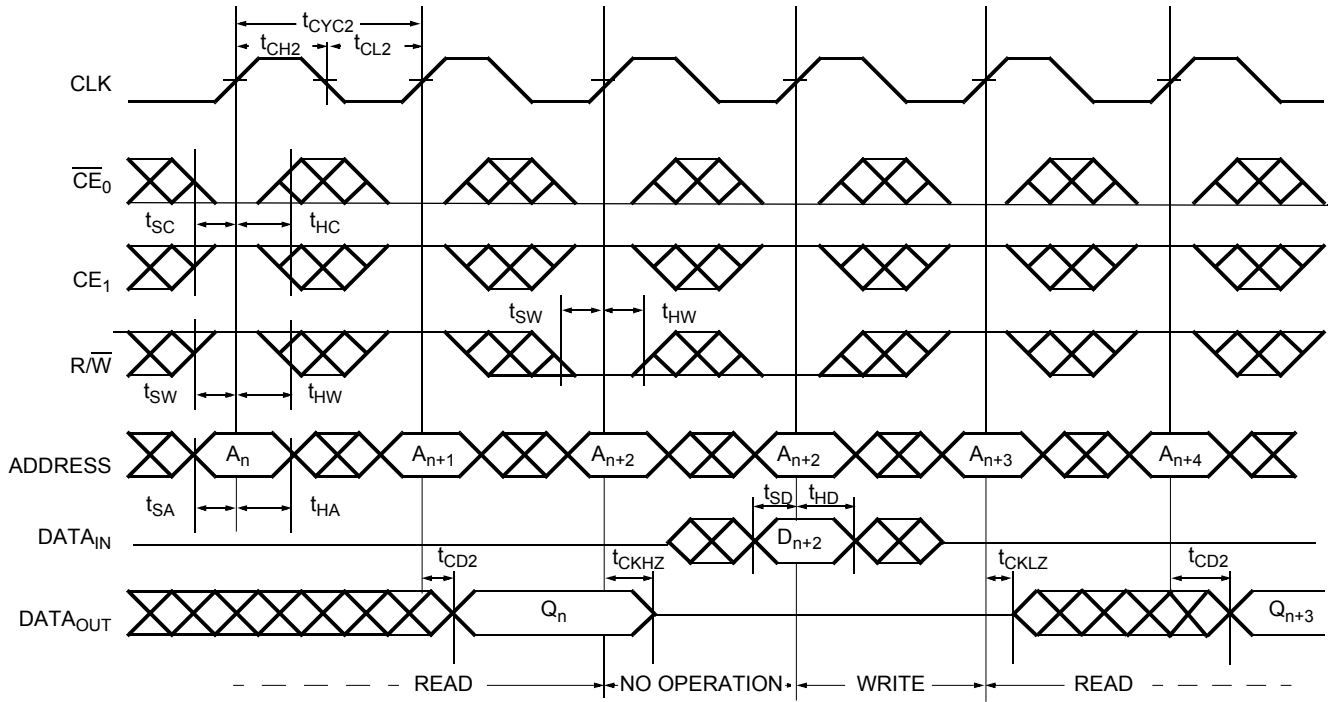

Switching Waveforms (continued)

Figure 11. Pipelined Read-to-Write-to-Read ( $\overline{\text{OE}}$  Controlled)<sup>[19, 26, 27, 28]</sup>

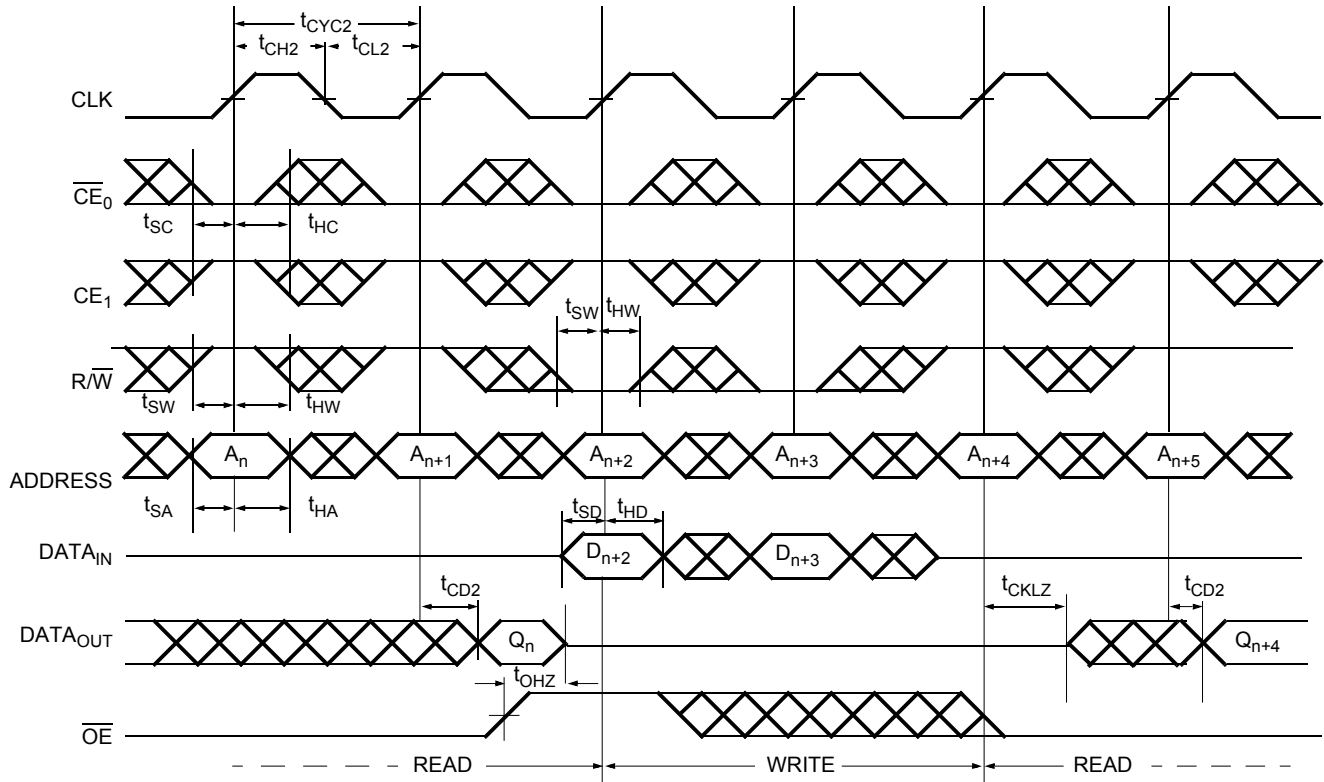

Notes

- 26. Output state (HIGH, LOW, or high-impedance) is determined by the previous cycle control signals.
- 27.  $\overline{\text{CE}}_0$  and  $\text{ADS} = \text{V}_{\text{IL}}$ ;  $\text{CE}_1$ ,  $\text{CNTEN}$ , and  $\text{CNTRST} = \text{V}_{\text{IH}}$ .
- 28. During "No Operation", data in memory at the selected address may be corrupted and should be re-written to ensure data integrity.

Switching Waveforms (continued)

Figure 12. Flow-Through Read-to-Write-to-Read ( $\overline{OE} = V_{IL}$ )<sup>[17, 19, 26, 27, 28]</sup>

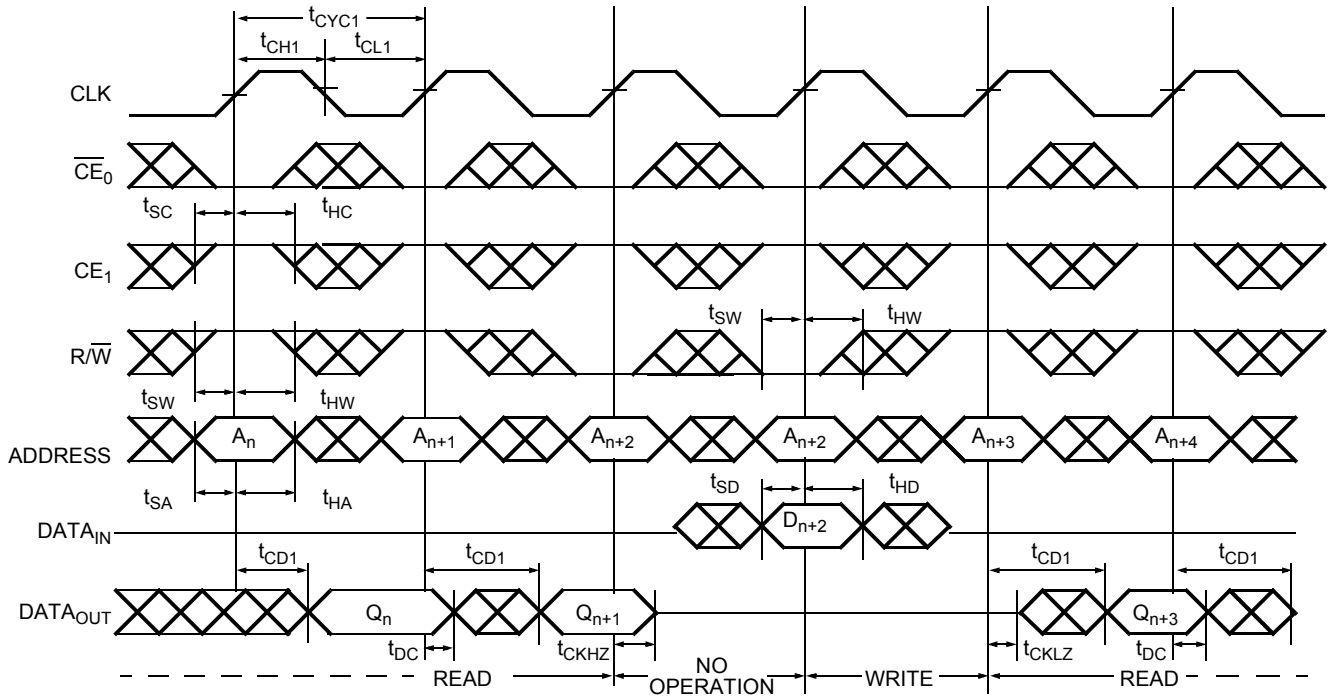
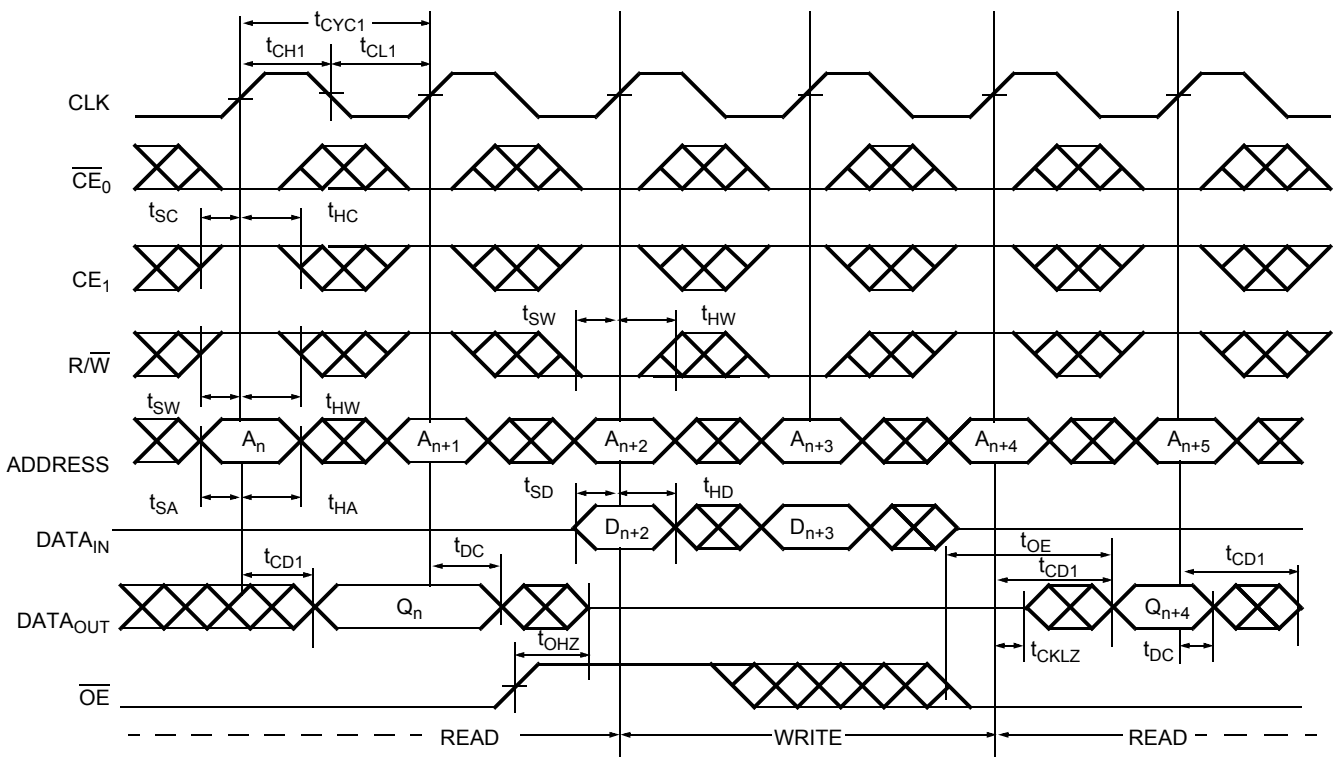

Figure 13. Flow-Through Read-to-Write-to-Read ( $\overline{OE}$  Controlled)<sup>[17, 20, 26, 27, 28]</sup>



Switching Waveforms (continued)

Figure 14. Pipelined Read with Address Counter Advance<sup>[29]</sup>

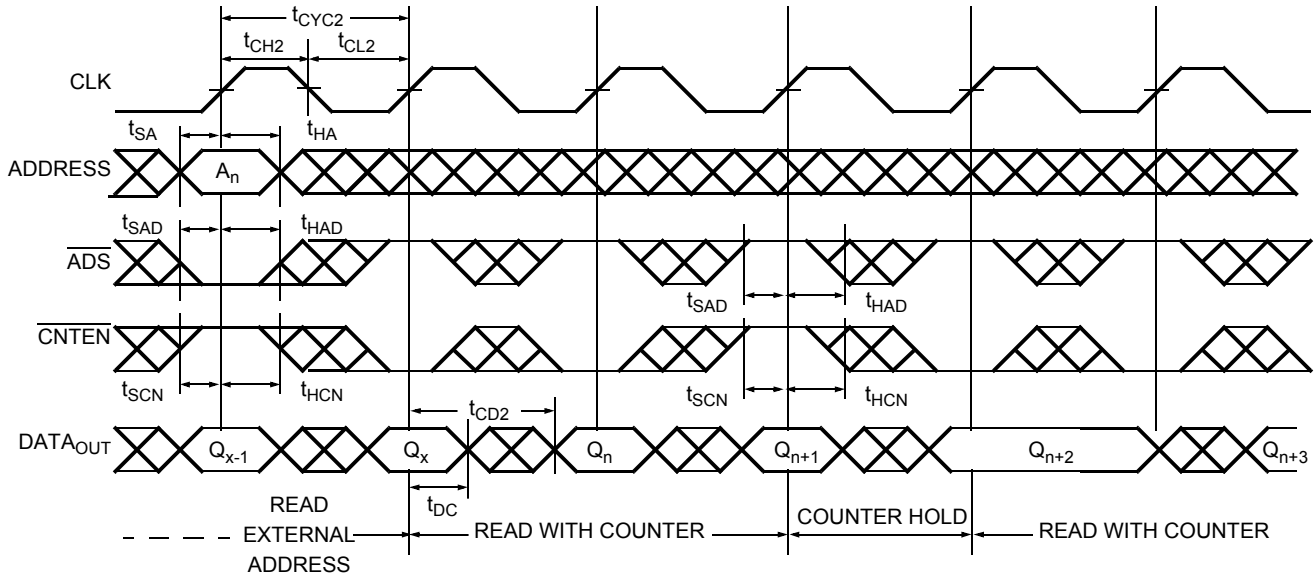
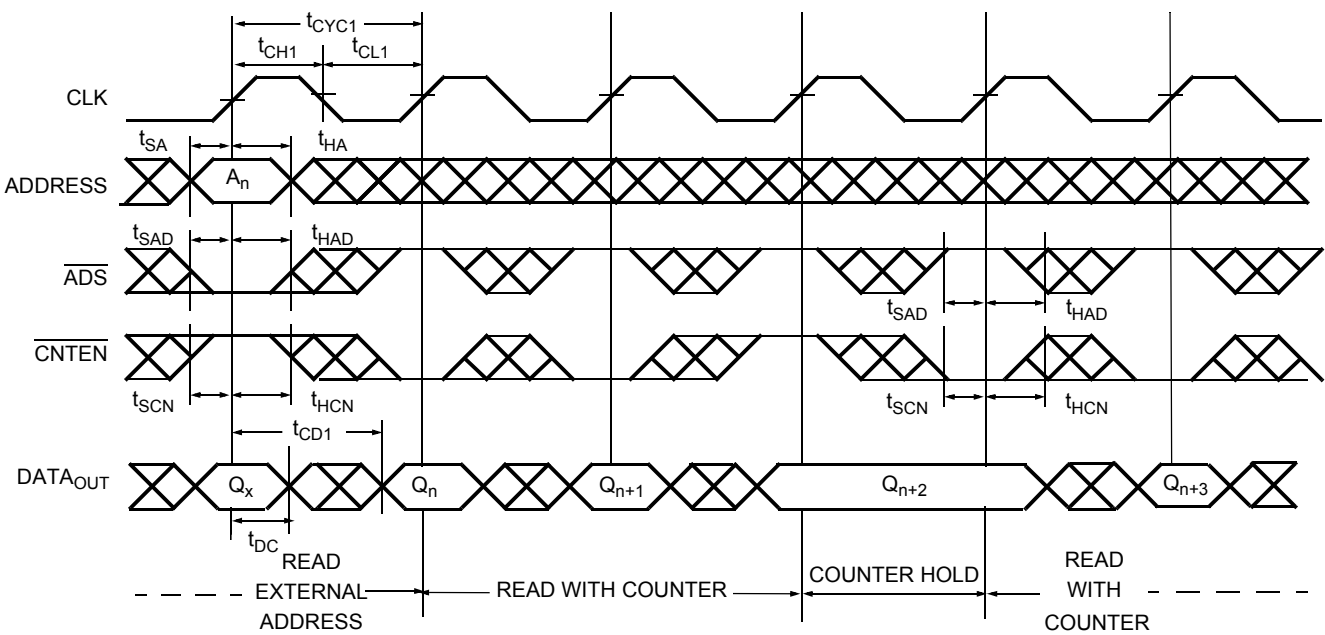

Figure 15. Flow-Through Read with Address Counter Advance<sup>[29]</sup>



**Note**  
29.  $\overline{CE}_0$  and  $\overline{OE} = V_{IL}$ ;  $CE_1$ ,  $R/\overline{W}$  and  $\overline{CNTRST} = V_{IH}$ .

**Switching Waveforms** (continued)

**Figure 16. Write with Address Counter Advance (Flow-Through or Pipelined Outputs)<sup>[30, 31]</sup>**

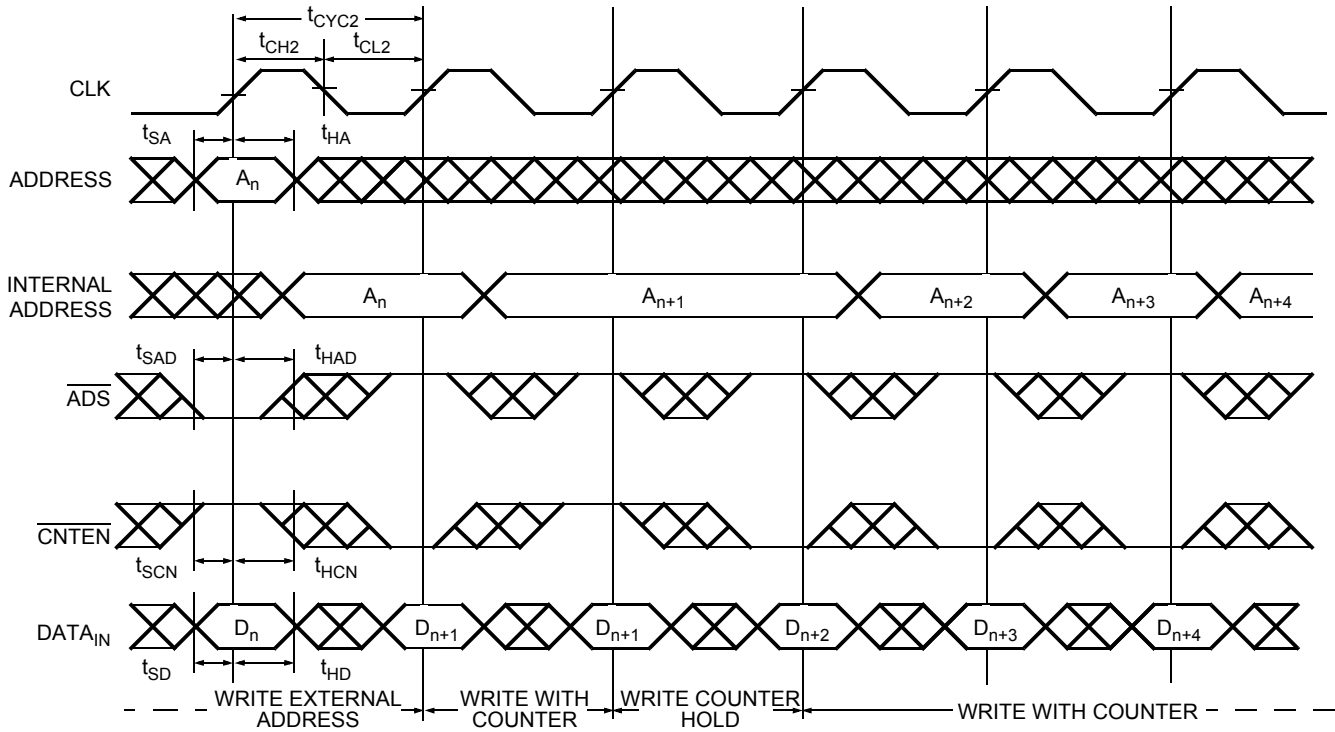

**Notes**

30.  $\overline{CE}_0$  and  $R/\overline{W} = V_{IL}$ ;  $\overline{CE}_1$  and  $\overline{CNTRST} = V_{IH}$ .

31. The "Internal Address" is equal to the "External Address" when  $\overline{ADS} = V_{IL}$  and equals the counter output when  $\overline{ADS} = V_{IH}$ .

Switching Waveforms (continued)

Figure 17. Counter Reset (Pipelined Outputs)<sup>[19, 26, 32, 33]</sup>

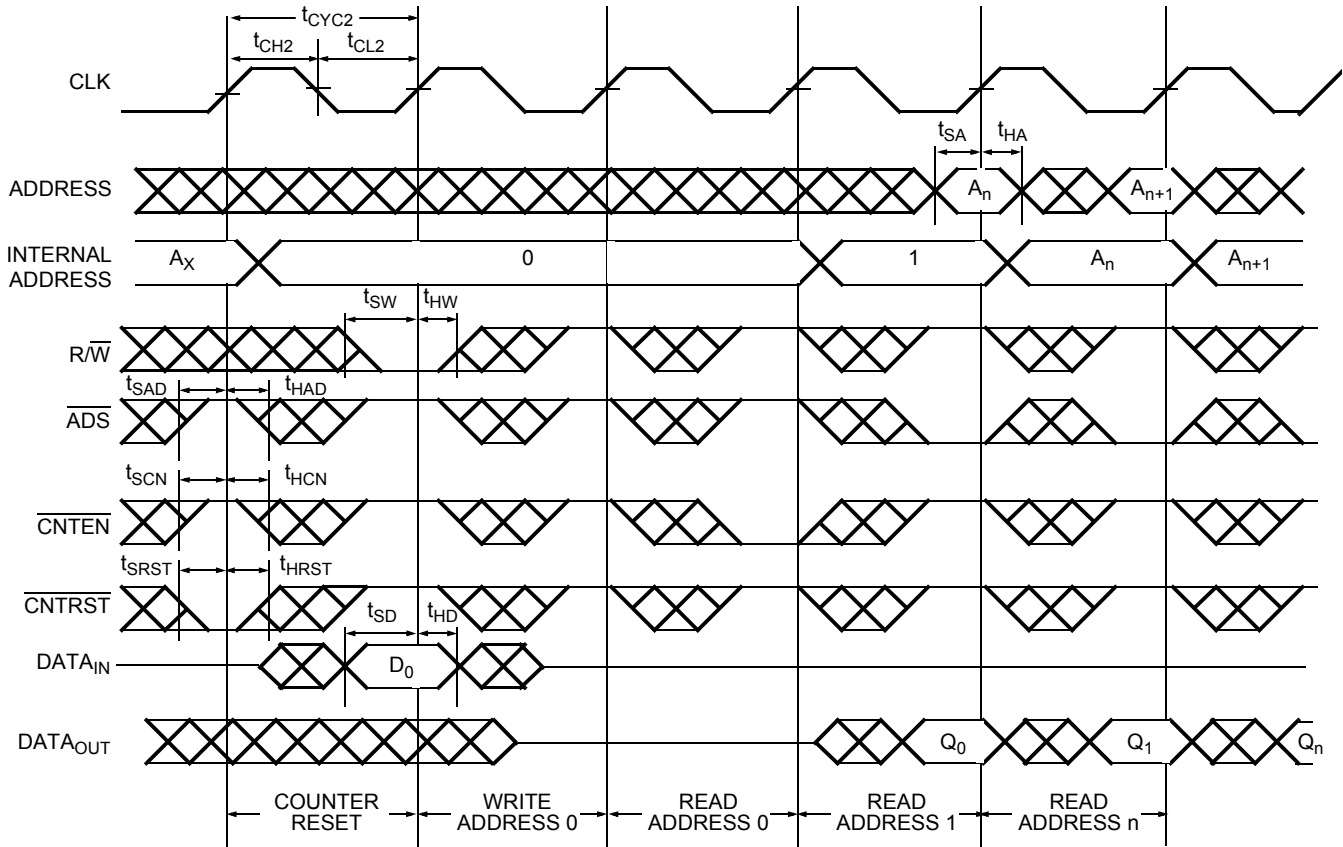





Notes





32.  $\overline{CE}_0 = V_{IL}$ ;  $CE_1 = V_{IH}$ .

33. No dead cycle exists during counter reset. A READ or WRITE cycle may be coincidental with the counter reset.

**Table 1. Read/Write and Enable Operation**<sup>[34, 35, 36]</sup>

Inputs					Outputs	Operation
OE	CLK	CE <sub>0</sub>	CE <sub>1</sub>	R/W	I/O <sub>0</sub> -I/O <sub>9</sub>	
X		H	X	X	High-Z	Deselected <sup>[37]</sup>
X		X	L	X	High-Z	Deselected <sup>[37]</sup>
X		L	H	L	D <sub>IN</sub>	Write
L		L	H	H	D <sub>OUT</sub>	Read <sup>[37]</sup>
H	X	L	H	X	High-Z	Outputs Disabled

**Table 2. Address Counter Control Operation**<sup>[34, 38, 39, 40]</sup>

Address	Previous Address	CLK	ADS	CNTEN	CNTRST	I/O	Mode	Operation
X	X		X	X	L	D <sub>out(0)</sub>	Reset	Counter Reset to Address 0
A <sub>n</sub>	X		L	X	H	D <sub>out(n)</sub>	Load	Address Load into Counter
X	A <sub>n</sub>		H	H	H	D <sub>out(n)</sub>	Hold	External Address Blocked—Counter Disabled
X	A <sub>n</sub>		H	L	H	D <sub>out(n+1)</sub>	Increment	Counter Enabled—Internal Address Generation

**Notes**

- 34. "X" = "Don't Care", "H" = V<sub>IH</sub>, "L" = V<sub>IL</sub>.
- 35. ADS, CNTEN, CNTRST = "Don't Care."
- 36. OE is an asynchronous input signal.
- 37. When CE changes state in the pipelined mode, deselection and read happen in the following clock cycle.
- 38. CE<sub>0</sub> and OE = V<sub>IL</sub>; CE<sub>1</sub> and R/W = V<sub>IH</sub>.
- 39. Data shown for flow-through mode; pipelined mode output will be delayed by one cycle.
- 40. Counter operation is independent of CE<sub>0</sub> and CE<sub>1</sub>.

## Ordering Information

### 32K x8 3.3V Synchronous Dual-Port SRAM

Speed (ns)	Ordering Code	Package Name	Package Type	Operating Range
6.5 <sup>[1]</sup>	CY7C09079V-6AC	A100	100-Pin Thin Quad Flat Pack	Commercial
7.5 <sup>[1]</sup>	CY7C09079V-7AC	A100	100-Pin Thin Quad Flat Pack	Commercial
	CY7C09079V-7AI	A100	100-Pin Thin Quad Flat Pack	Industrial
9	CY7C09079V-9AC	A100	100-Pin Thin Quad Flat Pack	Commercial
12	CY7C09079V-12AC	A100	100-Pin Thin Quad Flat Pack	Commercial

### 64K x8 3.3V Synchronous Dual-Port SRAM

Speed (ns)	Ordering Code	Package Name	Package Type	Operating Range
6.5 <sup>[1]</sup>	CY7C09089V-6AC	A100	100-Pin Thin Quad Flat Pack	Commercial
	CY7C09089V-6AXC	A100	100-Pin Pb-Free Thin Quad Flat Pack	Commercial
7.5 <sup>[1]</sup>	CY7C09089V-7AC	A100	100-Pin Thin Quad Flat Pack	Commercial
9	CY7C09089V-9AC	A100	100-Pin Thin Quad Flat Pack	Commercial
12	CY7C09089V-12AC	A100	100-Pin Thin Quad Flat Pack	Commercial
	CY7C09089V-12AXC	A100	100-Pin Pb-Free Thin Quad Flat Pack	Commercial
	CY7C09089V-12AXI	A100	100-Pin Pb-Free Thin Quad Flat Pack	Industrial

### 128K x8 3.3V Synchronous Dual-Port SRAM

Speed (ns)	Ordering Code	Package Name	Package Type	Operating Range
6.5 <sup>[1]</sup>	CY7C09099V-6AC	A100	100-Pin Thin Quad Flat Pack	Commercial
	CY7C09099V-6AXC	A100	100-Pin Pb-Free Thin Quad Flat Pack	Commercial
7.5 <sup>[1]</sup>	CY7C09099V-7AC	A100	100-Pin Thin Quad Flat Pack	Commercial
	CY7C09099V-7AI	A100	100-Pin Thin Quad Flat Pack	Industrial
	CY7C09099V-7AXI	A100	100-Pin Pb-Free Thin Quad Flat Pack	Industrial
9	CY7C09099V-9AC	A100	100-Pin Thin Quad Flat Pack	Commercial
	CY7C09099V-9AI	A100	100-Pin Thin Quad Flat Pack	Industrial
12	CY7C09099V-12AC	A100	100-Pin Thin Quad Flat Pack	Commercial
	CY7C09099V-12AXC	A100	100-Pin Pb-Free Thin Quad Flat Pack	Commercial

### 32K x9 3.3V Synchronous Dual-Port SRAM

Speed (ns)	Ordering Code	Package Name	Package Type	Operating Range
6.5 <sup>[1]</sup>	CY7C09179V-6AC	A100	100-Pin Thin Quad Flat Pack	Commercial
	CY7C09179V-6AXC	A100	100-Pin Pb-Free Thin Quad Flat Pack	Commercial
7.5 <sup>[1]</sup>	CY7C09179V-7AC	A100	100-Pin Thin Quad Flat Pack	Commercial
9	CY7C09179V-9C	A100	100-Pin Thin Quad Flat Pack	Commercial
12	CY7C09179V-12AC	A100	100-Pin Thin Quad Flat Pack	Commercial
	CY7C09179V-12AXC	A100	100-Pin Pb-Free Thin Quad Flat Pack	Commercial

**64K x9 3.3V Synchronous Dual-Port SRAM**

Speed (ns)	Ordering Code	Package Name	Package Type	Operating Range
6.5 <sup>[1]</sup>	CY7C09189V-6AC	A100	100-Pin Thin Quad Flat Pack	Commercial
	CY7C09189V-6AXC	A100	100-Pin Pb-Free Thin Quad Flat Pack	Commercial
7.5 <sup>[1]</sup>	CY7C09189V-7AC	A100	100-Pin Thin Quad Flat Pack	Commercial
9	CY7C09189V-9AC	A100	100-Pin Thin Quad Flat Pack	Commercial
12	CY7C09189V-12AC	A100	100-Pin Thin Quad Flat Pack	Commercial
	CY7C09189V-12AXC	A100	100-Pin Pb-Free Thin Quad Flat Pack	Commercial

**128K x9 3.3V Synchronous Dual-Port SRAM**

Speed (ns)	Ordering Code	Package Name	Package Type	Operating Range
6.5 <sup>[1]</sup>	CY7C09199V-6AC	A100	100-Pin Thin Quad Flat Pack	Commercial
	CY7C09199V-6AXC	A100	100-Pin Pb-Free Thin Quad Flat Pack	Commercial
7.5 <sup>[1]</sup>	CY7C09199V-7AC	A100	100-Pin Thin Quad Flat Pack	Commercial
	CY7C09199V-7AXC	A100	100-Pin Pb-Free Thin Quad Flat Pack	Commercial
9	CY7C09199V-9AC	A100	100-Pin Thin Quad Flat Pack	Commercial
	CY7C09199V-9AXC	A100	100-Pin Pb-Free Thin Quad Flat Pack	Commercial
	CY7C09199V-9AI	A100	100-Pin Thin Quad Flat Pack	Industrial
	CY7C09199V-9AXI	A100	100-Pin Pb-Free Thin Quad Flat Pack	Industrial
12	CY7C09199V-12AC	A100	100-Pin Thin Quad Flat Pack	Commercial
	CY7C09199V-12AXC	A100	100-Pin Pb-Free Thin Quad Flat Pack	Commercial

### Package Diagram

Figure 18. 100-Pin Thin Plastic Quad Flat Pack (TQFP) A100 (51-85048)

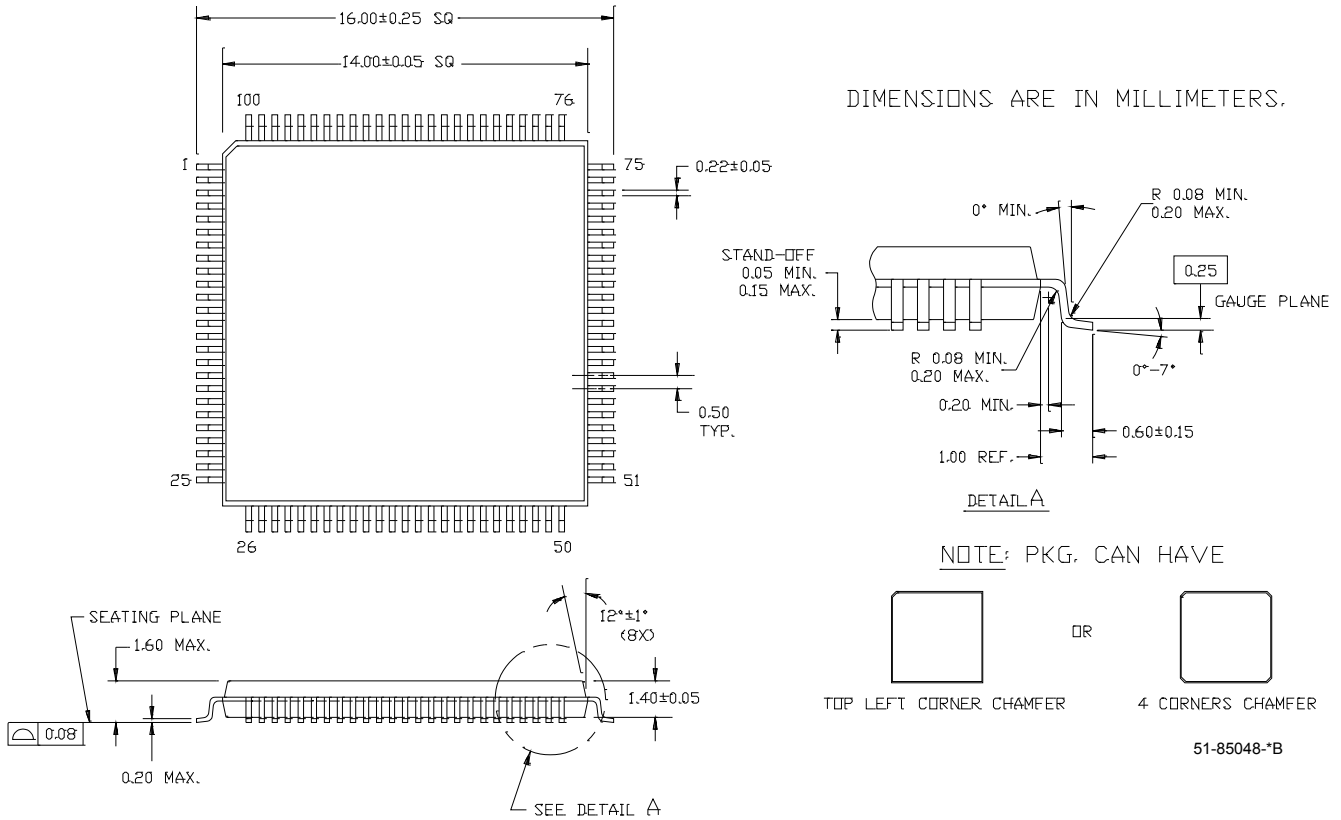

## Document History Page

Document Title: CY7C09079V/89V/99V, CY7C09179V/89V/99V 3.3V 32K/64K/128K x 8/9Synchronous Dual Port Static RAM				
Document Number: 38-06043				
Rev.	ECN No.	Orig. of Change	Orig. of Change	Description of Change
**	110191	SZV	09/29/01	Change from Spec number: 38-00667 to 38-06043
*A	122293	RBI	12/27/02	Power up requirements added to Operating Conditions Information
*B	365034	PCN	See ECN	Added Pb-Free Logo Added Pb-Free Part Ordering Information: CY7C09089V-6AXC, CY7C09089V-12AXC, CY7C09099V-6AXC, CY7C09099V-7AI, CY7C09099V-7AXI, CY7C09099V-12AXC, CY7C09179V-6AXC, CY7C09179V-12AXC, CY7C09189V-6AXC, CY7C09189V-12AXC, CY7C09199V-6AXC, CY7C09199V-7AXC, CY7C09199V-9AXC, CY7C09199V-9AXI, CY7C09199V-12AXC
*C	2623658	VKN/PYRS	12/17/08	Added CY7C09089V-12AXI part in the Ordering information table

## Sales, Solutions, and Legal Information

### Worldwide Sales and Design Support

Cypress maintains a worldwide network of offices, solution centers, manufacturer's representatives, and distributors. To find the office closest to you, visit us at [cypress.com/sales](http://cypress.com/sales).

#### Products

PSoC	<a href="http://psoc.cypress.com">psoc.cypress.com</a>
Clocks & Buffers	<a href="http://clocks.cypress.com">clocks.cypress.com</a>
Wireless	<a href="http://wireless.cypress.com">wireless.cypress.com</a>
Memories	<a href="http://memory.cypress.com">memory.cypress.com</a>
Image Sensors	<a href="http://image.cypress.com">image.cypress.com</a>

#### PSoC Solutions

General	<a href="http://psoc.cypress.com/solutions">psoc.cypress.com/solutions</a>
Low Power/Low Voltage	<a href="http://psoc.cypress.com/low-power">psoc.cypress.com/low-power</a>
Precision Analog	<a href="http://psoc.cypress.com/precision-analog">psoc.cypress.com/precision-analog</a>
LCD Drive	<a href="http://psoc.cypress.com/lcd-drive">psoc.cypress.com/lcd-drive</a>
CAN 2.0b	<a href="http://psoc.cypress.com/can">psoc.cypress.com/can</a>
USB	<a href="http://psoc.cypress.com/usb">psoc.cypress.com/usb</a>

© Cypress Semiconductor Corporation, 2005-2008. The information contained herein is subject to change without notice. Cypress Semiconductor Corporation assumes no responsibility for the use of any circuitry other than circuitry embodied in a Cypress product. Nor does it convey or imply any license under patent or other rights. Cypress products are not warranted nor intended to be used for medical, life support, life saving, critical control or safety applications, unless pursuant to an express written agreement with Cypress. Furthermore, Cypress does not authorize its products for use as critical components in life-support systems where a malfunction or failure may reasonably be expected to result in significant injury to the user. The inclusion of Cypress products in life-support systems application implies that the manufacturer assumes all risk of such use and in doing so indemnifies Cypress against all charges.

Any Source Code (software and/or firmware) is owned by Cypress Semiconductor Corporation (Cypress) and is protected by and subject to worldwide patent protection (United States and foreign), United States copyright laws and international treaty provisions. Cypress hereby grants to licensee a personal, non-exclusive, non-transferable license to copy, use, modify, create derivative works of, and compile the Cypress Source Code and derivative works for the sole purpose of creating custom software and or firmware in support of licensee product to be used only in conjunction with a Cypress integrated circuit as specified in the applicable agreement. Any reproduction, modification, translation, compilation, or representation of this Source Code except as specified above is prohibited without the express written permission of Cypress.

Disclaimer: CYPRESS MAKES NO WARRANTY OF ANY KIND, EXPRESS OR IMPLIED, WITH REGARD TO THIS MATERIAL, INCLUDING, BUT NOT LIMITED TO, THE IMPLIED WARRANTIES OF MERCHANTABILITY AND FITNESS FOR A PARTICULAR PURPOSE. Cypress reserves the right to make changes without further notice to the materials described herein. Cypress does not assume any liability arising out of the application or use of any product or circuit described herein. Cypress does not authorize its products for use as critical components in life-support systems where a malfunction or failure may reasonably be expected to result in significant injury to the user. The inclusion of Cypress' product in a life-support systems application implies that the manufacturer assumes all risk of such use and in doing so indemnifies Cypress against all charges.

Use may be limited by and subject to the applicable Cypress software license agreement.

## Looking for pricing, stock, or lifecycle information?

Click below to explore more details on WIN SOURCE:

 [View CY7C09089V-12AC](#) on WIN SOURCE

 [Infineon Technologies](#) Information

## Optimize Your Supply Chain with WIN SOURCE Solutions

-  Global Sourcing Solution
-  Obsolete Management
-  Cost Control Management
-  Shortage Management
-  Alternative Solution
-  Excess Inventory Management