



## SN75ALS174A Quadruple Differential Line Driver

### 1 Features

- Meets or Exceeds the Requirements of ANSI EIA/TIA-422-B and RS-485
- High-Speed Advanced Low-Power Schottky Circuitry
- Designed for up to 20-Mbit/s Operation in Both Serial and Parallel Applications
- Designed for Multipoint Transmission on Long Bus Lines in Noisy Environments
- Low Supply Current Requirements 55 mA Max
- Wide Positive and Negative Input/Output Bus Voltage Ranges
- Driver Output Capacity: 60 mA
- Thermal-Shutdown Protection
- Driver Positive- and Negative-Current Limiting
- Functionally Interchangeable With SN75174

### 2 Applications

- Motor Drives
- Factory Automation and Control

### 3 Description

The SN75ALS174A is a quadruple line driver with tri-state differential outputs. It is designed to meet the requirements of ANSI Standards EIA/TIA-422-B and RS-485. This device is optimized for balanced multipoint bus transmission at rates of up to 20 Mbit/s.

Each driver features wide positive and negative common-mode output voltage ranges that make them suitable for party-line applications in noisy environments.

The SN75ALS174A provides positive- and negative-current limiting and thermal shutdown for protection from line fault conditions on the transmission bus line. Shutdown occurs at a junction temperature of approximately 150°C.

The SN75ALS174A is characterized for operation from 0°C to 70°C.

#### Device Information<sup>(1)</sup>

PART NUMBER	PACKAGE	BODY SIZE (NOM)
SN75ALS174A	PDIP (N) (16)	19.3 mm x 6.50 mm
	SOIC (DW) (20)	12.8 mm x 7.50 mm
	TSSOP (PW) (20)	6.50 mm x 4.40 mm

(1) For all available packages, see the orderable addendum at the end of the data sheet.

#### Function Table (each driver)<sup>(1) (2)</sup>

INPUT A	ENABLES	OUTPUTS	
		Y	Z
H	H	H	L
L	H	L	H
X	L	Z	Z

(1) H = high level, L = low level, X = irrelevant.

(2) Z = high impedance (off)

#### N Package (Top View)

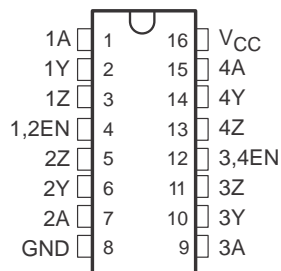

#### DW, PW Package (Top View)

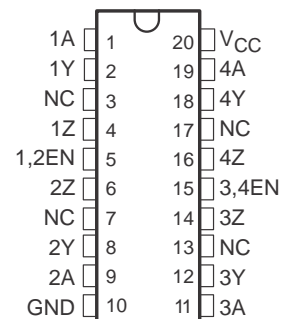

NC – No internal connection



## Table of Contents

<b>1 Features</b> .....	<b>1</b>	<b>6 Parameter Measurement Information</b> .....	<b>5</b>
<b>2 Applications</b> .....	<b>1</b>	<b>7 Device and Documentation Support</b> .....	<b>8</b>
<b>3 Description</b> .....	<b>1</b>	7.1 Documentation Support .....	8
<b>4 Revision History</b> .....	<b>2</b>	7.2 Receiving Notification of Documentation Updates....	8
<b>5 Specifications</b> .....	<b>3</b>	7.3 Community Resources .....	8
5.1 Absolute Maximum Ratings .....	3	7.4 Trademarks .....	8
5.2 Dissipation Rating Table .....	3	7.5 Electrostatic Discharge Caution .....	8
5.3 Recommended Operating Conditions .....	3	7.6 Glossary .....	8
5.4 Electrical Characteristics .....	4	<b>8 Mechanical, Packaging, and Orderable</b>	
5.5 Switching Characteristics .....	4	<b>Information</b> .....	<b>8</b>

## 4 Revision History

NOTE: Page numbers for previous revisions may differ from page numbers in the current version.

### Changes from Revision E (April 1998) to Revision F

Page

- |   |          |
|---|----------|
| <ul style="list-style-type: none"> <li>Added the PW package, <i>Applications</i> list, <i>Device Information</i> table, <i>Device and Documentation Support</i> section, and <i>Mechanical, Packaging, and Orderable Information</i> section. ....</li> </ul> | <b>1</b> |
|---|----------|

## 5 Specifications

### 5.1 Absolute Maximum Ratings

over operating free-air temperature range (unless otherwise noted)<sup>(1)</sup>

	MIN	MAX	UNIT
Supply voltage, $V_{CC}$ <sup>(2)</sup>		7	V
Input voltage, $V_I$		7	V
Output voltage range, $V_O$	–9	14	V
Continuous total dissipation	See the <i>Dissipation Rating</i> table		
Storage temperature, $T_{stg}$	–65	150	°C

- (1) Stresses beyond those listed under *Absolute Maximum Ratings* may cause permanent damage to the device. These are stress ratings only, which do not imply functional operation of the device at these or any other conditions beyond those indicated under *Recommended Operating Conditions*. Exposure to absolute-maximum-rated conditions for extended periods may affect device reliability.
- (2) All voltage values are with respect to network GND.

### 5.2 Dissipation Rating Table

PACKAGE	$T_A \leq 25^\circ\text{C}$ POWER RATING	DERATING FACTOR	$T_A = 70^\circ\text{C}$ POWER RATING	$T_A = 85^\circ\text{C}$ POWER RATING
DW	1125 mW	9.0 mW/°C	720 mW	596 mW
N	1150 mW	9.2 mW/°C	736 mW	598 mW

### 5.3 Recommended Operating Conditions

over operating free-air temperature range (unless otherwise noted)

		MIN	NOM	MAX	UNIT
$V_{CC}$	Supply voltage	4.75	5	5.25	V
$V_{IH}$	High-level input voltage	2			V
$V_{IL}$	Low-level input voltage			0.8	V
$V_{OC}$	Common-mode output voltage			12	V
				–7	V
$I_{OH}$	High-level output current			–60	mA
$I_{OL}$	Low-level output current			60	mA
$T_A$	Operating free-air temperature	0		70	°C

## 5.4 Electrical Characteristics

over operating free-air temperature range (unless otherwise noted)

PARAMETER		TEST CONDITIONS	MIN	TYP <sup>(1)</sup>	MAX	UNIT
V <sub>IK</sub>	Input clamp voltage	I <sub>I</sub> = -18 mA			-1.5	V
V <sub>O</sub>	Output voltage	I <sub>O</sub> = 0	0		6	V
V <sub>OD1</sub>	Differential output voltage	I <sub>O</sub> = 0	1.5		6	V
V <sub>OD2</sub>	Differential output voltage	R <sub>L</sub> = 100 Ω	1/2 V <sub>OD1</sub> or 2 <sup>(2)</sup>			V
		R <sub>L</sub> = 54 Ω	1.5	2.5	5	V
V <sub>OD3</sub>	Differential output voltage	See <sup>(3)</sup>	1.5		5	V
Δ V <sub>OD</sub>	Change in magnitude of differential output voltage <sup>(4)</sup>	R <sub>L</sub> = 54 Ω or 100 Ω	See Figure 1		±0.2	V
V <sub>OC</sub>	Common-mode output voltage <sup>(5)</sup>	R <sub>L</sub> = 54 Ω or 100 Ω	See Figure 1		3	V
					-1	V
Δ V <sub>OC</sub>	Change in magnitude of common-mode output voltage <sup>(4)</sup>	R <sub>L</sub> = 54 Ω or 100 Ω	See Figure 1		±0.2	V
I <sub>O</sub>	Output current with power off	V <sub>CC</sub> = 0, V <sub>O</sub> = -7 V to 12 V			±100	μA
I <sub>OZ</sub>	High-impedance-state output current	V <sub>O</sub> = -7 V to 12 V			±100	μA
I <sub>IH</sub>	High-level input current	V <sub>I</sub> = 2.7 V			20	μA
I <sub>IL</sub>	Low-level input current	V <sub>I</sub> = 0.4 V			-100	μA
I <sub>OS</sub>	Short-circuit output current	V <sub>O</sub> = -7 V to 12 V			±250	mA
I <sub>CC</sub>	Supply current (all drivers)	No load	Outputs enabled	36	55	mA
			Outputs disabled	16	30	mA

 (1) All typical values are at V<sub>CC</sub> = 5 V and T<sub>A</sub> = 25°C.

 (2) The minimum V<sub>OD2</sub> with a 100-Ω load is either 1/2 V<sub>OD1</sub> or 2 V, whichever is greater.

(3) See EIA Standard RS-485, Figures 3-5, Test Termination Measurement 2.

 (4) Δ|V<sub>OD</sub>| and Δ|V<sub>OC</sub>| are the changes in magnitude of V<sub>OD</sub> and V<sub>OC</sub>, respectively, that occur when the input is changed from a high level to a low level.

 (5) In ANSI Standard EIA/TIA-422-B, V<sub>OC</sub>, which is the average of the two output voltages with respect to ground, is called output offset voltage, V<sub>OS</sub>.

## 5.5 Switching Characteristics

 over operating free-air temperature range (unless otherwise noted), C<sub>L</sub> = 50 pF

PARAMETER	TEST CONDITIONS	MIN	TYP	MAX	UNIT	
t <sub>d(OD)</sub>	Differential output delay time	R <sub>L</sub> = 54 Ω, See Figure 2	9	15	22	ns
t <sub>PZH</sub>	Output enable time to high level	R <sub>L</sub> = 110 Ω, See Figure 3	30	45	70	ns
t <sub>PZL</sub>	Output enable time to low level	R <sub>L</sub> = 110 Ω, See Figure 4	25	40	65	ns
t <sub>PHZ</sub>	Output disable time from high level	R <sub>L</sub> = 110 Ω, See Figure 3	10	20	35	ns
t <sub>PLZ</sub>	Output disable time from low level	R <sub>L</sub> = 110 Ω, See Figure 4	10	30	45	ns

## 6 Parameter Measurement Information

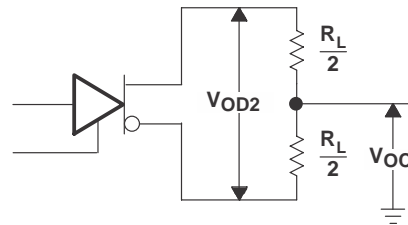

Copyright © 2018, Texas Instruments Incorporated

**Figure 1. Differential and Common-Mode Output Voltages**

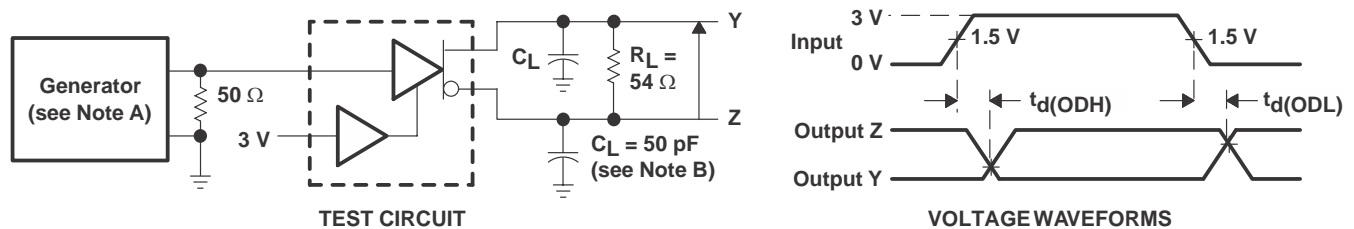

Copyright © 2018, Texas Instruments Incorporated

- A. The input pulse is supplied by a generator having the following characteristics: PRR = 1 MHz,  $Z_O = 50 \Omega$ , duty cycle = 50%,  $t_r$  5 ns,  $t_f$  5 ns.
- B.  $C_L$  includes probe and stray capacitance.

**Figure 2. Differential-Output Test Circuit and Delay and Transition Times Voltage Waveforms**

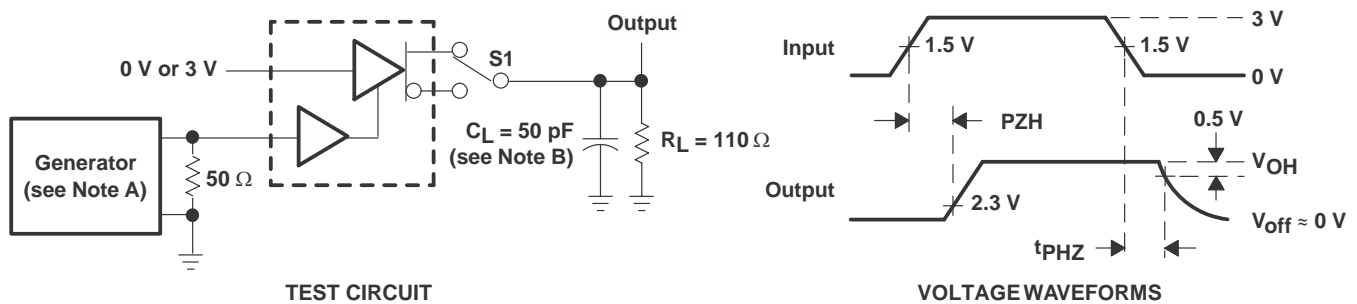

Copyright © 2018, Texas Instruments Incorporated

- A. The input pulse is supplied by a generator having the following characteristics: PRR = 1 MHz,  $Z_O = 50 \Omega$ , duty cycle = 50%,  $t_r$  5 ns,  $t_f$  5 ns.
- B.  $C_L$  includes probe and stray capacitance.

**Figure 3. Test Circuit and Voltage Waveforms,  $t_{PZH}$  and  $t_{PHZ}$**

Parameter Measurement Information (continued)

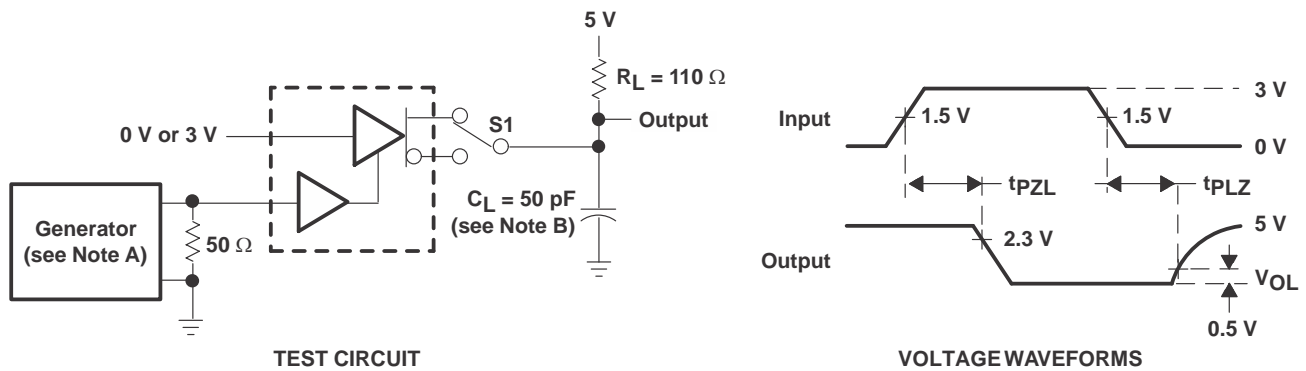

Copyright © 2018, Texas Instruments Incorporated

- A. The input pulse is supplied by a generator having the following characteristics: PRR = 1 MHz,  $Z_O = 50 \Omega$ , duty cycle = 50%,  $t_r = 5 \text{ ns}$ ,  $t_f = 5 \text{ ns}$ .
- B.  $C_L$  includes probe and stray capacitance.

Figure 4. Test Circuit and Voltage Waveforms,  $t_{PZL}$  and  $t_{PLZ}$

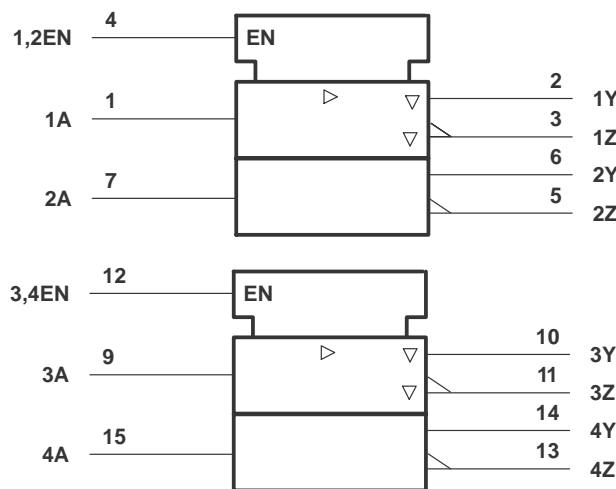

- (1) This symbol is in accordance with ANSI/IEEE Std 91-1984 and IEC Publication 617-12.
- (2) Pin numbers shown are for the N package.

Figure 5. Logic Symbol

Parameter Measurement Information (continued)

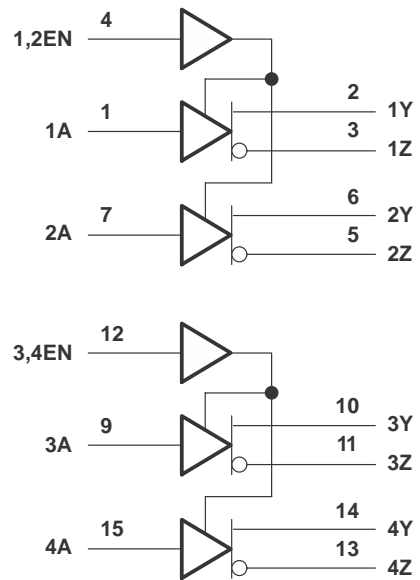

(1) Pin numbers shown are for the N package.

Figure 6. Logic Diagram (Positive Logic)

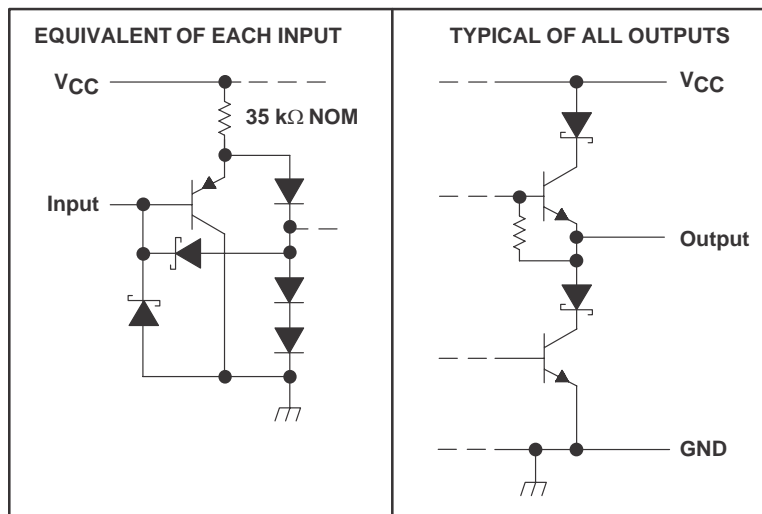

Copyright © 2018, Texas Instruments Incorporated

Figure 7. Schematics of Inputs and Outputs

## 7 Device and Documentation Support

### 7.1 Documentation Support

### 7.2 Receiving Notification of Documentation Updates

To receive notification of documentation updates, navigate to the device product folder on ti.com. In the upper right corner, click on *Alert me* to register and receive a weekly digest of any product information that has changed. For change details, review the revision history included in any revised document.

### 7.3 Community Resources

The following links connect to TI community resources. Linked contents are provided "AS IS" by the respective contributors. They do not constitute TI specifications and do not necessarily reflect TI's views; see TI's [Terms of Use](#).

**TI E2E™ Online Community** *TI's Engineer-to-Engineer (E2E) Community*. Created to foster collaboration among engineers. At e2e.ti.com, you can ask questions, share knowledge, explore ideas and help solve problems with fellow engineers.

**Design Support** *TI's Design Support* Quickly find helpful E2E forums along with design support tools and contact information for technical support.

### 7.4 Trademarks

E2E is a trademark of Texas Instruments.  
All other trademarks are the property of their respective owners.

### 7.5 Electrostatic Discharge Caution



This integrated circuit can be damaged by ESD. Texas Instruments recommends that all integrated circuits be handled with appropriate precautions. Failure to observe proper handling and installation procedures can cause damage.

ESD damage can range from subtle performance degradation to complete device failure. Precision integrated circuits may be more susceptible to damage because very small parametric changes could cause the device not to meet its published specifications.

### 7.6 Glossary

[SLYZ022](#) — *TI Glossary*.

This glossary lists and explains terms, acronyms, and definitions.

## 8 Mechanical, Packaging, and Orderable Information

The following pages include mechanical, packaging, and orderable information. This information is the most current data available for the designated devices. This data is subject to change without notice and revision of this document. For browser-based versions of this data sheet, refer to the left-hand navigation.

**PACKAGING INFORMATION**

Orderable Device	Status (1)	Package Type	Package Drawing	Pins	Package Qty	Eco Plan (2)	Lead/Ball Finish (6)	MSL Peak Temp (3)	Op Temp (°C)	Device Marking (4/5)	Samples
SN75ALS174ADW	ACTIVE	SOIC	DW	20	25	Green (RoHS & no Sb/Br)	CU NIPDAU	Level-1-260C-UNLIM	0 to 70	75ALS174A	<a href="#">Samples</a>
SN75ALS174ADWE4	ACTIVE	SOIC	DW	20	25	Green (RoHS & no Sb/Br)	CU NIPDAU	Level-1-260C-UNLIM	0 to 70	75ALS174A	<a href="#">Samples</a>
SN75ALS174ADWR	ACTIVE	SOIC	DW	20	2000	Green (RoHS & no Sb/Br)	CU NIPDAU	Level-1-260C-UNLIM	0 to 70	75ALS174A	<a href="#">Samples</a>
SN75ALS174AN	ACTIVE	PDIP	N	16	25	Green (RoHS & no Sb/Br)	CU NIPDAU	N / A for Pkg Type	0 to 70	SN75ALS174AN	<a href="#">Samples</a>
SN75ALS174APWR	ACTIVE	TSSOP	PW	20	2000	Green (RoHS & no Sb/Br)	CU NIPDAU	Level-1-260C-UNLIM	0 to 70	LS174A	<a href="#">Samples</a>

(1) The marketing status values are defined as follows:

**ACTIVE:** Product device recommended for new designs.

**LIFEBUY:** TI has announced that the device will be discontinued, and a lifetime-buy period is in effect.

**NRND:** Not recommended for new designs. Device is in production to support existing customers, but TI does not recommend using this part in a new design.

**PREVIEW:** Device has been announced but is not in production. Samples may or may not be available.

**OBSELETE:** TI has discontinued the production of the device.

(2) **RoHS:** TI defines "RoHS" to mean semiconductor products that are compliant with the current EU RoHS requirements for all 10 RoHS substances, including the requirement that RoHS substance do not exceed 0.1% by weight in homogeneous materials. Where designed to be soldered at high temperatures, "RoHS" products are suitable for use in specified lead-free processes. TI may reference these types of products as "Pb-Free".

**RoHS Exempt:** TI defines "RoHS Exempt" to mean products that contain lead but are compliant with EU RoHS pursuant to a specific EU RoHS exemption.

**Green:** TI defines "Green" to mean the content of Chlorine (Cl) and Bromine (Br) based flame retardants meet JS709B low halogen requirements of <=1000ppm threshold. Antimony trioxide based flame retardants must also meet the <=1000ppm threshold requirement.

(3) MSL, Peak Temp. - The Moisture Sensitivity Level rating according to the JEDEC industry standard classifications, and peak solder temperature.

(4) There may be additional marking, which relates to the logo, the lot trace code information, or the environmental category on the device.

(5) Multiple Device Markings will be inside parentheses. Only one Device Marking contained in parentheses and separated by a "-" will appear on a device. If a line is indented then it is a continuation of the previous line and the two combined represent the entire Device Marking for that device.

(6) Lead/Ball Finish - Orderable Devices may have multiple material finish options. Finish options are separated by a vertical ruled line. Lead/Ball Finish values may wrap to two lines if the finish value exceeds the maximum column width.

**Important Information and Disclaimer:**The information provided on this page represents TI's knowledge and belief as of the date that it is provided. TI bases its knowledge and belief on information provided by third parties, and makes no representation or warranty as to the accuracy of such information. Efforts are underway to better integrate information from third parties. TI has taken and continues to take reasonable steps to provide representative and accurate information but may not have conducted destructive testing or chemical analysis on incoming materials and chemicals. TI and TI suppliers consider certain information to be proprietary, and thus CAS numbers and other limited information may not be available for release.

In no event shall TI's liability arising out of such information exceed the total purchase price of the TI part(s) at issue in this document sold by TI to Customer on an annual basis.

## TAPE AND REEL INFORMATION



### QUADRANT ASSIGNMENTS FOR PIN 1 ORIENTATION IN TAPE



\*All dimensions are nominal

Device	Package Type	Package Drawing	Pins	SPQ	Reel Diameter (mm)	Reel Width W1 (mm)	A0 (mm)	B0 (mm)	K0 (mm)	P1 (mm)	W (mm)	Pin1 Quadrant
SN75ALS174ADWR	SOIC	DW	20	2000	330.0	24.4	10.8	13.3	2.7	12.0	24.0	Q1
SN75ALS174APWR	TSSOP	PW	20	2000	330.0	16.4	6.95	7.1	1.6	8.0	16.0	Q1

**TAPE AND REEL BOX DIMENSIONS**

\*All dimensions are nominal

Device	Package Type	Package Drawing	Pins	SPQ	Length (mm)	Width (mm)	Height (mm)
SN75ALS174ADWR	SOIC	DW	20	2000	350.0	350.0	43.0
SN75ALS174APWR	TSSOP	PW	20	2000	367.0	367.0	38.0



PW (R-PDSO-G20)

PLASTIC SMALL OUTLINE



- NOTES:
- A. All linear dimensions are in millimeters.
  - B. This drawing is subject to change without notice.
  - C. Publication IPC-7351 is recommended for alternate design.
  - D. Laser cutting apertures with trapezoidal walls and also rounding corners will offer better paste release. Customers should contact their board assembly site for stencil design recommendations. Refer to IPC-7525 for other stencil recommendations.
  - E. Customers should contact their board fabrication site for solder mask tolerances between and around signal pads.

N (R-PDIP-T\*\*)

PLASTIC DUAL-IN-LINE PACKAGE

16 PINS SHOWN



- NOTES:
- A. All linear dimensions are in inches (millimeters).
  - B. This drawing is subject to change without notice.
  - Falls within JEDEC MS-001, except 18 and 20 pin minimum body length (Dim A).
  - The 20 pin end lead shoulder width is a vendor option, either half or full width.

# DW0020A



# PACKAGE OUTLINE

## SOIC - 2.65 mm max height

SOIC



4220724/A 05/2016

**NOTES:**

1. All linear dimensions are in millimeters. Dimensions in parenthesis are for reference only. Dimensioning and tolerancing per ASME Y14.5M.
2. This drawing is subject to change without notice.
3. This dimension does not include mold flash, protrusions, or gate burrs. Mold flash, protrusions, or gate burrs shall not exceed 0.15 mm per side.
4. This dimension does not include interlead flash. Interlead flash shall not exceed 0.43 mm per side.
5. Reference JEDEC registration MS-013.

# EXAMPLE BOARD LAYOUT

DW0020A

SOIC - 2.65 mm max height

SOIC



LAND PATTERN EXAMPLE  
SCALE:6X



SOLDER MASK DETAILS

4220724/A 05/2016

NOTES: (continued)

- 6. Publication IPC-7351 may have alternate designs.
- 7. Solder mask tolerances between and around signal pads can vary based on board fabrication site.

# EXAMPLE STENCIL DESIGN

DW0020A

SOIC - 2.65 mm max height

SOIC



SOLDER PASTE EXAMPLE  
BASED ON 0.125 mm THICK STENCIL  
SCALE:6X

4220724/A 05/2016

NOTES: (continued)

8. Laser cutting apertures with trapezoidal walls and rounded corners may offer better paste release. IPC-7525 may have alternate design recommendations.
9. Board assembly site may have different recommendations for stencil design.

## IMPORTANT NOTICE AND DISCLAIMER

TI PROVIDES TECHNICAL AND RELIABILITY DATA (INCLUDING DATASHEETS), DESIGN RESOURCES (INCLUDING REFERENCE DESIGNS), APPLICATION OR OTHER DESIGN ADVICE, WEB TOOLS, SAFETY INFORMATION, AND OTHER RESOURCES "AS IS" AND WITH ALL FAULTS, AND DISCLAIMS ALL WARRANTIES, EXPRESS AND IMPLIED, INCLUDING WITHOUT LIMITATION ANY IMPLIED WARRANTIES OF MERCHANTABILITY, FITNESS FOR A PARTICULAR PURPOSE OR NON-INFRINGEMENT OF THIRD PARTY INTELLECTUAL PROPERTY RIGHTS.

These resources are intended for skilled developers designing with TI products. You are solely responsible for (1) selecting the appropriate TI products for your application, (2) designing, validating and testing your application, and (3) ensuring your application meets applicable standards, and any other safety, security, or other requirements. These resources are subject to change without notice. TI grants you permission to use these resources only for development of an application that uses the TI products described in the resource. Other reproduction and display of these resources is prohibited. No license is granted to any other TI intellectual property right or to any third party intellectual property right. TI disclaims responsibility for, and you will fully indemnify TI and its representatives against, any claims, damages, costs, losses, and liabilities arising out of your use of these resources.

TI's products are provided subject to TI's Terms of Sale ([www.ti.com/legal/termsofsale.html](http://www.ti.com/legal/termsofsale.html)) or other applicable terms available either on [ti.com](http://ti.com) or provided in conjunction with such TI products. TI's provision of these resources does not expand or otherwise alter TI's applicable warranties or warranty disclaimers for TI products.

Mailing Address: Texas Instruments, Post Office Box 655303, Dallas, Texas 75265  
Copyright © 2019, Texas Instruments Incorporated

## Looking for pricing, stock, or lifecycle information?

Click below to explore more details on WIN SOURCE:

 [View SN75ALS174ADW on WIN SOURCE](#)

 [Texas Instruments](#) Information

## Optimize Your Supply Chain with WIN SOURCE Solutions

-  Global Sourcing Solution
-  Obsolete Management
-  Cost Control Management
-  Shortage Management
-  Alternative Solution
-  Excess Inventory Management