



# THE DATASHEET OF LM2748MTC/NOPB



# LM2745 / LM2748 Synchronous Buck Controller with Pre-Bias Startup, and Optional Clock Synchronization

Check for Samples: [LM2745](#), [LM2748](#)

## FEATURES

- Switching Frequency from 50 kHz to 1 MHz
- Switching Frequency Synchronize Range 250 kHz to 1 MHz (LM2745 Only)
- Startup with a Pre-biased Output Load
- Power Stage Input Voltage from 1V to 14V
- Control Stage Input Voltage from 3V to 6V
- Output Voltage Adjustable Down to 0.6V
- Power Good Flag and Shutdown
- Output Overvoltage and Undervoltage Detection
- $\pm 1.5\%$  Feedback Voltage Accuracy Over Temperature
- Low-side Adjustable Current Sensing
- Adjustable Soft-start
- Tracking and Sequencing with Shutdown and Soft Start Pins
- TSSOP-14 Package

## APPLICATIONS

- Down Conversion from 3.3V
- Cable Modem, DSL and ADSL
- Laser Jet and Ink Jet Printers
- Low Voltage Power Modules
- DSP, ASIC, Core and I/O

## DESCRIPTION

The LM2745/8 are high-speed synchronous buck regulator controllers with an accurate feedback voltage accuracy of  $\pm 1.5\%$ . It can provide simple down conversion to output voltages as low as 0.6V. Though the control sections of the IC are rated for 3 to 6V, the driver sections are designed to accept input supply rails as high as 14V. The use of adaptive non-overlapping MOSFET gate drivers helps avoid potential shoot-through problems while maintaining high efficiency. The IC is designed for the more cost-effective option of driving only N-channel MOSFETs in both the high-side and low-side positions. It senses the low-side switch voltage drop for providing a simple, adjustable current limit.

The LM2745/8 features a fixed-frequency voltage-mode PWM control architecture which is adjustable from 50 kHz to 1 MHz with one external resistor. In addition, the LM2745 also allows the switching frequency to be synchronized to an external clock signal over the range of 250 kHz to 1 MHz. This wide range of switching frequency gives the power supply designer the flexibility to make better tradeoffs between component size, cost and efficiency.

Features include the ability to startup with a pre-biased load on the output, soft-start, input undervoltage lockout (UVLO) and Power Good (based on both undervoltage and overvoltage detection). In addition, the shutdown pin of the IC can be used for providing startup delay, and the soft-start pin can be used for implementing precise tracking, for the purpose of sequencing with respect to an external rail.

## Typical Application

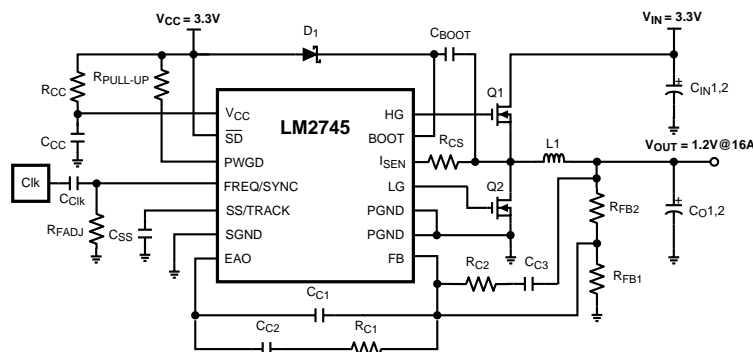

Please be aware that an important notice concerning availability, standard warranty, and use in critical applications of Texas Instruments semiconductor products and disclaimers thereto appears at the end of this data sheet.

All trademarks are the property of their respective owners.

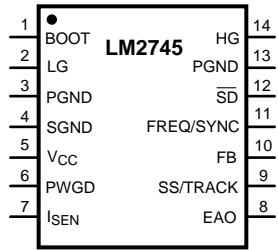

**Figure 1. 14-Lead Plastic TSSOP,  $\theta_{JA} = 155^{\circ}\text{C/W}$   
Top View  
Package Number PW0014A**

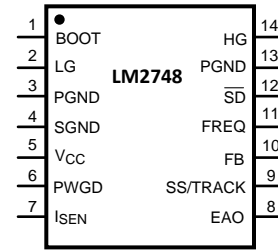

**Figure 2. 14-Lead Plastic TSSOP,  $\theta_{JA} = 155^{\circ}\text{C/W}$   
Top View  
Package Number PW0014A**

### Pin Descriptions

<b>BOOT (Pin 1)</b> - Bootstrap pin. This is the supply rail for the high-side gate driver. When the high-side MOSFET turns on, the voltage on this pin should be at least one gate threshold above the regulator input voltage $V_{IN}$ to properly turn on the MOSFET. See <a href="#">MOSFET Gate Drivers</a> in the <a href="#">Application Information</a> section for more details on how to select MOSFETs.
<b>LG (Pin 2)</b> - Low-gate drive pin. This is the gate drive for the low-side N-channel MOSFET. This signal is interlocked with the high-side gate drive HG (Pin 14), so as to avoid shoot-through.
<b>PGND (Pins 3, 13)</b> - Power ground. This is also the ground for the low-side MOSFET driver. Both the pins must be connected together on the PCB and form a ground plane, which is usually also the system ground.
<b>SGND (Pin 4)</b> - Signal ground. It should be connected appropriately to the ground plane with due regard to good layout practices in switching power regulator circuits.
<b>VCC (Pin 5)</b> Supply rail for the control sections of the IC.
<b>PWGD (Pin 6)</b> - Power Good pin. This is an open drain output, which is typically meant to be connected to $V_{CC}$ or any other low voltage source through a pull-up resistor. Choose the pull-up resistor so that the current going into this pin is kept below 1 mA. A recommended value for the pull-up resistor is 100 k $\Omega$ for most applications. The voltage on this pin is thus pulled low under output undervoltage or overvoltage fault conditions and also under input UVLO.
<b>I<sub>SEN</sub> (Pin 7)</b> - Current limit threshold setting pin. This sources a fixed 40 $\mu\text{A}$ current. A resistor of appropriate value should be connected between this pin and the drain of the low-side MOSFET (switch node). The minimum value for this resistor is 1 k $\Omega$ .
<b>EAO (Pin 8)</b> - Output of the error amplifier. The voltage level on this pin is compared with an internally generated ramp signal to determine the duty cycle. This pin is necessary for compensating the control loop.
<b>SS/TRACK (Pin 9)</b> - Soft-start and tracking pin. This pin is internally connected to the non-inverting input of the error amplifier during soft-start, and in fact any time the SS/TRACK pin voltage happens to be below the internal reference voltage. For the basic soft-start function, a capacitor of minimum value 1 nF is connected from this pin to ground. To track the rising ramp of another power supply's output, connect a resistor divider from the output of that supply to this pin as described in Application Information.
<b>FB (Pin 10)</b> - Feedback pin. This is the inverting input of the error amplifier, which is used for sensing the output voltage and compensating the control loop.
<b>FREQ/SYNC (Pin 11)</b> - Frequency adjust pin. The switching frequency is set by connecting a resistor of suitable value between this pin and ground. Some typical values (rounded up to the nearest standard values) are 150 k $\Omega$ for 200 kHz, 100 k $\Omega$ for 300 kHz, 51.1 k $\Omega$ for 500 kHz, 18.7 k $\Omega$ for 1 MHz. This pin is also used in the LM2745 to synchronize to an external clock.
<b>SD (Pin 12)</b> - IC shutdown pin. Pull this pin to $V_{CC}$ to ensure the IC is enabled. Connect to ground to disable the IC. Under shutdown, both high-side and low-side drives are off. This pin also features a precision threshold for power supply sequencing purposes, as well as a low threshold to ensure minimal quiescent current.
<b>HG (Pin 14)</b> - High-gate drive pin. This is the gate drive for the high-side N-channel MOSFET. This signal is interlocked with LG (Pin 2) to avoid shoot-through.



These devices have limited built-in ESD protection. The leads should be shorted together or the device placed in conductive foam during storage or handling to prevent electrostatic damage to the MOS gates.

### Absolute Maximum Ratings<sup>(1)(2)</sup>

$V_{CC}$		-0.3 to 7V
BOOT Voltage		-0.3 to 18V
$I_{SEN}$		-0.3 to 14V
FREQ/SYNC Voltage		-0.5 to $V_{CC} + 0.3V$
All other pins		-0.3 to $V_{CC} + 0.3V$
Junction Temperature		150°C
Storage Temperature		-65°C to 150°C
Soldering Information	Lead Temperature (soldering, 10sec)	260°C
	Infrared or Convection (20sec)	235°C
ESD Rating <sup>(3)</sup>		2kV

- (1) Absolute maximum ratings indicate limits beyond which damage to the device may occur. **Operating ratings** indicate conditions for which the device operates correctly. **Operating Ratings** do not imply specified performance limits.
- (2) If Military/Aerospace specified devices are required, please contact the Texas Instruments Sales Office/ Distributors for availability and specifications.
- (3) ESD using the human body model which is a 100pF capacitor discharged through a 1.5 kΩ resistor into each pin.

### Operating Ratings

Supply Voltage Range, $V_{CC}$ <sup>(1)</sup>	3V to 6V
BOOT Voltage Range	1V to 17V
Junction Temperature Range ( $T_J$ )	-40°C to +125°C
Thermal Resistance ( $\theta_{JA}$ )	155°C/W

- (1) The power MOSFETs can run on a separate 1V to 14V rail (Input voltage,  $V_{IN}$ ). Practical lower limit of  $V_{IN}$  depends on selection of the external MOSFET. See the [MOSFET GATE DRIVERS](#) section under [Application Information](#) for further details.

### Electrical Characteristics

$V_{CC} = 3.3V$  unless otherwise indicated. Typicals and limits appearing in plain type apply for  $T_A = T_J = 25^\circ C$ . Limits appearing in boldface type apply over full Operating Temperature Range. Datasheet min/max specification limits are specified by design, test, or statistical analysis.

Symbol	Parameter	Conditions	Min	Typ	Max	Units	
$V_{FB}$	FB Pin Voltage	$V_{CC} = 3V$ to 6V	<b>0.591</b>	0.6	<b>0.609</b>	V	
$V_{ON}$	UVLO Thresholds	$V_{CC}$ Rising $V_{CC}$ Falling		2.79 2.42		V	
$I_{Q\_VCC}$	Operating $V_{CC}$ Current	$V_{CC} = 3.3V, V_{SD} = 3.3V$ $f_{SW} = 600$ kHz	LM2745	<b>1.1</b>	1.7	<b>2.3</b>	mA
			LM2748	<b>1.0</b>	1.5	<b>2.1</b>	
		$V_{CC} = 5V, V_{SD} = 3.3V$ $f_{SW} = 600$ kHz	LM2745	<b>1.3</b>	2	<b>2.6</b>	
		LM2748	<b>1.0</b>	1.8	<b>2.6</b>		
	Shutdown $V_{CC}$ Current	$V_{CC} = 3.3V, V_{SD} = 0V$		1	<b>3</b>	μA	
$t_{PWGD1}$	PWGD Pin Response Time	$V_{FB}$ Rising		10		μs	
$t_{PWGD2}$	PWGD Pin Response Time	$V_{FB}$ Falling		10		μs	
$I_{SS-ON}$	SS Pin Source Current	$V_{SS} = 0V$	<b>7</b>	10	<b>14</b>	μA	
$I_{SS-OC}$	SS Pin Sink Current During Over Current	$V_{SS} = 2.0V$		90		μA	
$I_{SEN-TH}$	$I_{SEN}$ Pin Source Current Trip Point		<b>25</b>	40	<b>55</b>	μA	
$I_{FB}$	FB Pin Current	Sourcing		20		nA	
<b>ERROR AMPLIFIER</b>							
GBW	Error Amplifier Unity Gain Bandwidth			9		MHz	
G	Error Amplifier DC Gain			118		dB	
SR	Error Amplifier Slew Rate			2		V/μs	
$I_{EAO}$	EAO Pin Current Sourcing and Sinking Capability			14 16		mA	

## Electrical Characteristics (continued)

$V_{CC} = 3.3V$  unless otherwise indicated. Typicals and limits appearing in plain type apply for  $T_A = T_J = 25^\circ C$ . Limits appearing in boldface type apply over full Operating Temperature Range. Datasheet min/max specification limits are specified by design, test, or statistical analysis.

Symbol	Parameter	Conditions	Min	Typ	Max	Units
$V_{EAO}$	Error Amplifier Output Voltage	Minimum		1		V
		Maximum		2.2		V
<b>GATE DRIVE</b>						
$I_{Q\_BOOT}$	BOOT Pin Quiescent Current	$V_{BOOT} = 12V, V_{SD} = 0$		18	<b>90</b>	$\mu A$
$R_{HG\_UP}$	High-Side MOSFET Driver Pull-Up ON resistance	$V_{BOOT} = 5V @ 350 mA$ Sourcing		2.7		$\Omega$
$R_{HG\_DN}$	High-Side MOSFET Driver Pull-Down ON resistance	350 mA Sinking		0.8		$\Omega$
$R_{LG\_UP}$	Low-Side MOSFET Driver Pull-Up ON resistance	$V_{BOOT} = 5V @ 350 mA$ Sourcing		2.7		$\Omega$
$R_{LG\_DN}$	Low-Side MOSFET Driver Pull-Down ON resistance	350 mA Sinking		0.8		$\Omega$
<b>OSCILLATOR</b>						
$f_{SW}$	PWM Frequency	$R_{FADJ} = 750 k\Omega$		50		kHz
		$R_{FADJ} = 100 k\Omega$		300		
		$R_{FADJ} = 42.2 k\Omega$	<b>475</b>	600	<b>725</b>	
		$R_{FADJ} = 18.7 k\Omega$		1000		
	LM2745 External Synchronizing Signal Frequency	Voltage Swing = 0V to $V_{CC}$	250		1000	
$SYNC_L$	LM2745 Synchronization Signal Low Threshold	$f_{SW} = 250 kHz$ to 1 MHz			1	V
$SYNC_H$	LM2745 Synchronization Signal High Threshold	$f_{SW} = 250 kHz$ to 1 MHz	2			V
$D_{MAX}$	Max High-Side Duty Cycle	$f_{SW} = 300 kHz$ $f_{SW} = 600 kHz$ $f_{SW} = 1 MHz$		86 78 67		%
<b>LOGIC INPUTS AND OUTPUTS</b>						
$V_{STBY\_IH}$	Standby High Trip Point	$V_{FB} = 0.575V, V_{BOOT} = 3.3V$ $V_{SD}$ Rising			<b>1.1</b>	V
$V_{STBY\_IL}$	Standby Low Trip Point	$V_{FB} = 0.575V, V_{BOOT} = 3.3V$ $V_{SD}$ Falling	<b>0.232</b>			V
$V_{SD\_IH}$	$\overline{SD}$ Pin Logic High Trip Point	$V_{SD}$ Rising			<b>1.3</b>	V
$V_{SD\_IL}$	$\overline{SD}$ Pin Logic Low Trip Point	$V_{SD}$ Falling	<b>0.8</b>			V
$V_{PWGD\_TH\_LO}$	PWGD Pin Trip Points	$V_{FB}$ Falling	<b>0.408</b>	0.434	<b>0.457</b>	V
$V_{PWGD\_TH\_HI}$	PWGD Pin Trip Points	$V_{FB}$ Rising	<b>0.677</b>	0.710	<b>0.742</b>	V
$V_{PWGD\_HYS}$	PWGD Hysteresis	$V_{FB}$ Falling $V_{FB}$ Rising		60 90		mV

Typical Performance Characteristics

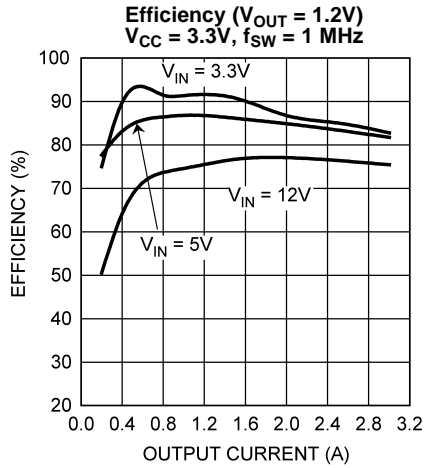

Figure 3.

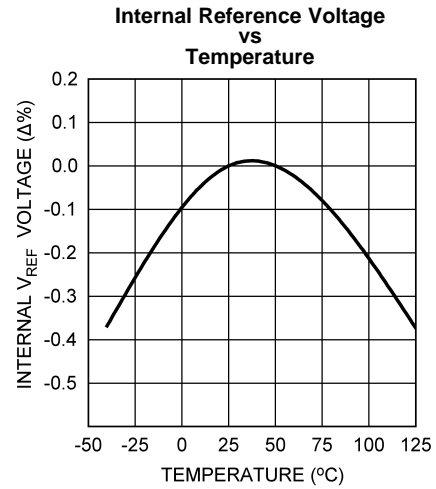

Figure 4.

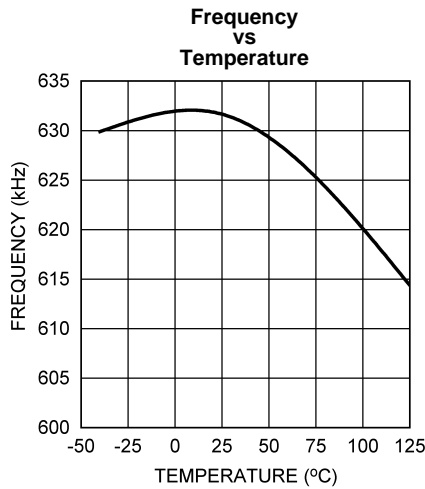

Figure 5.

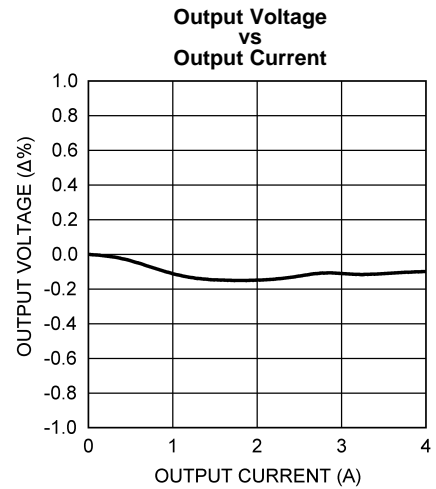

Figure 6.

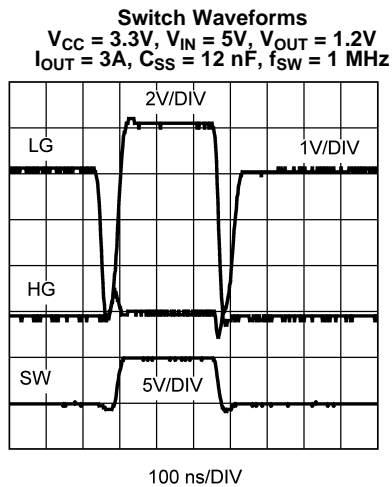

Figure 7.

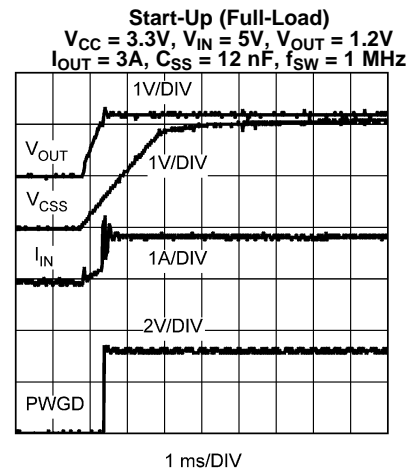
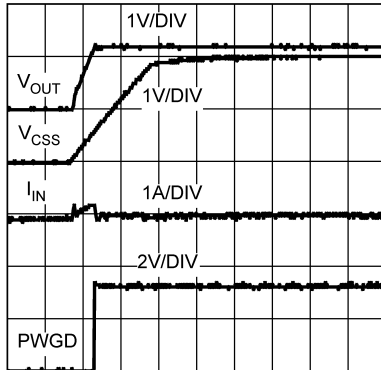

Figure 8.

**Typical Performance Characteristics (continued)**

**Start-Up (No-Load)**  
 $V_{CC} = 3.3V$ ,  $V_{IN} = 5V$ ,  $V_{OUT} = 1.2V$   
 $C_{SS} = 12\text{ nF}$ ,  $f_{sw} = 1\text{ MHz}$



1 ms/DIV  
**Figure 9.**

**Shutdown (Full-Load)**  
 $V_{CC} = 3.3V$ ,  $V_{IN} = 5V$ ,  $V_{OUT} = 1.2V$   
 $I_{OUT} = 3A$ ,  $C_{SS} = 12\text{ nF}$ ,  $f_{sw} = 1\text{ MHz}$

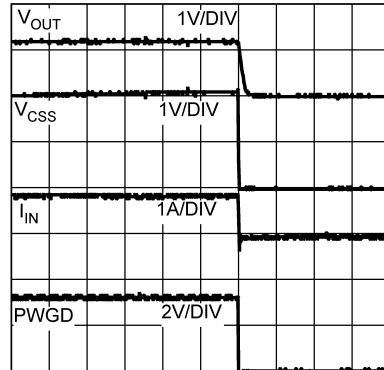

1 ms/DIV  
**Figure 10.**

**Load Transient Response**  
 $V_{CC} = 3.3V$ ,  $V_{IN} = 14V$ ,  $V_{OUT} = 1.2V$   
 $f_{sw} = 1\text{ MHz}$

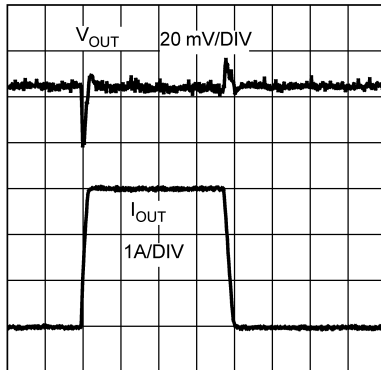

500 μs/DIV  
**Figure 11.**

**Line Transient Response ( $V_{IN} = 3V$  to  $9V$ )**  
 $V_{CC} = 3.3V$ ,  $V_{OUT} = 1.2V$   
 $I_{OUT} = 2A$ ,  $f_{sw} = 1\text{ MHz}$

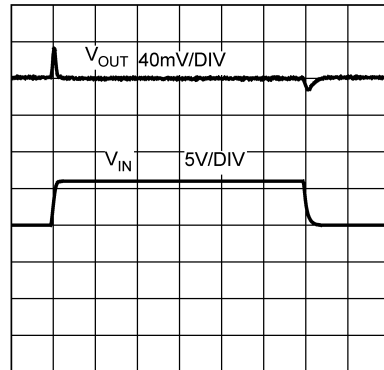

1 ms/DIV  
**Figure 12.**

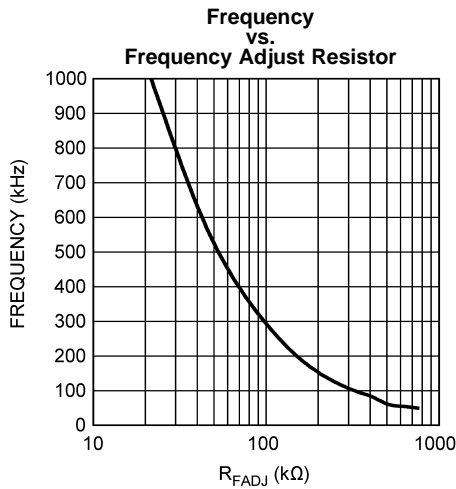

**Figure 13.**

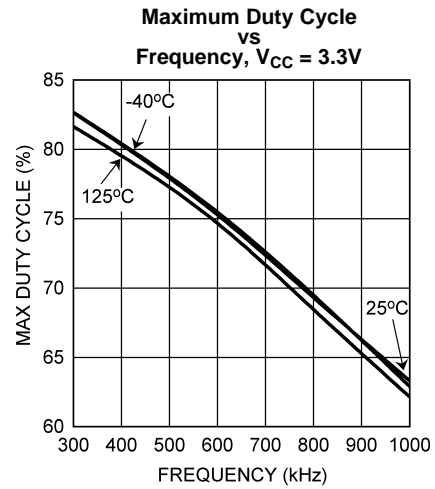

**Figure 14.**

**Typical Performance Characteristics (continued)**

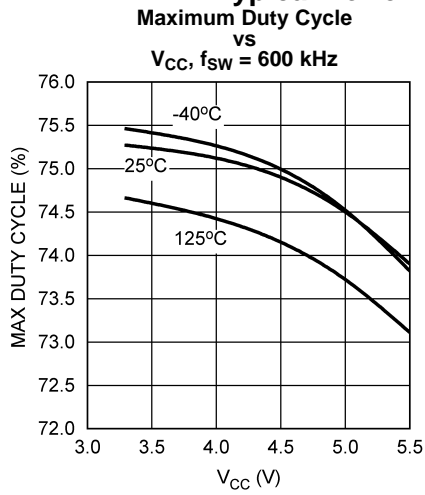

Figure 15.

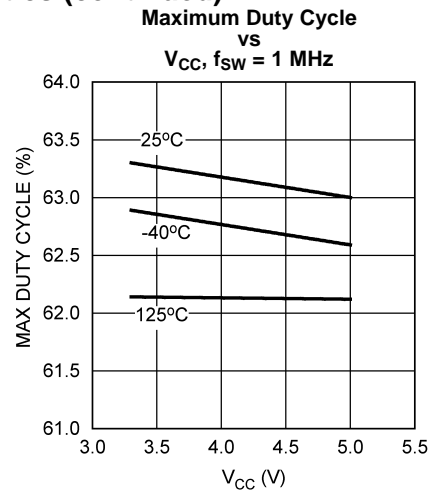
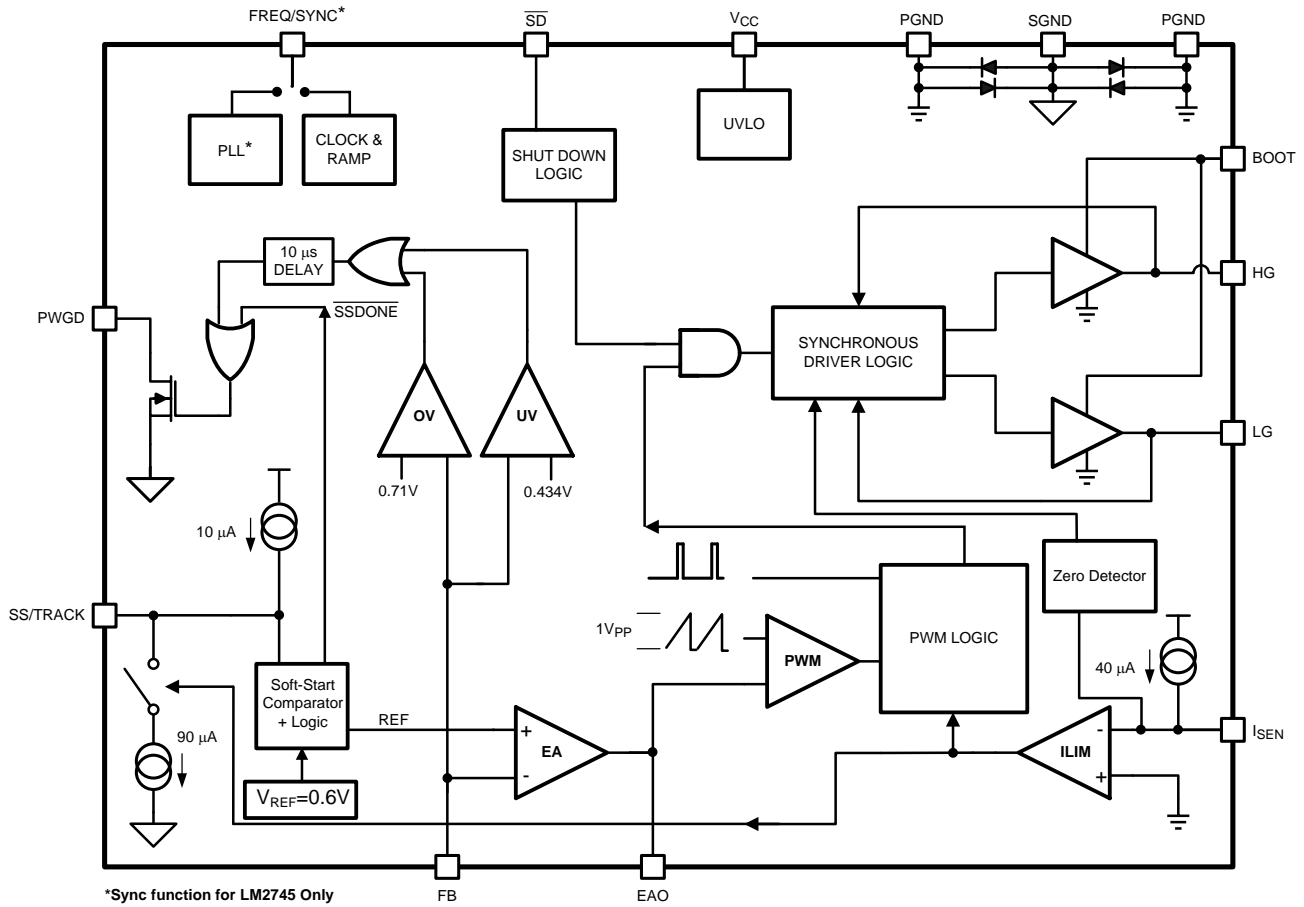

Figure 16.

Block Diagram



## APPLICATION INFORMATION

The LM2745/8 is a voltage-mode, high-speed synchronous buck regulator with a PWM control scheme. It is designed for use in set-top boxes, thin clients, DSL/Cable modems, and other applications that require high efficiency buck converters. It has output shutdown ( $\overline{SD}$ ), input undervoltage lock-out (UVLO) mode and power good (PWGD) flag (based on overvoltage and undervoltage detection). The overvoltage and undervoltage signals are OR-gated to drive the power good signal and provide a logic signal to the system if the output voltage goes out of regulation. Current limit is achieved by sensing the voltage  $V_{DS}$  across the low side MOSFET. The LM2745/8 is also able to start-up with the output pre-biased with a load. The LM2745 also allows for the switching frequency to be synchronized with an external clock source.

### START UP/SOFT-START

When  $V_{CC}$  exceeds 2.79V and the shutdown pin ( $\overline{SD}$ ) sees a logic high, the soft-start period begins. Then an internal, fixed 10  $\mu$ A source begins charging the soft-start capacitor. During soft-start the voltage on the soft-start capacitor  $C_{SS}$  is connected internally to the non-inverting input of the error amplifier. The soft-start period lasts until the voltage on the soft-start capacitor exceeds the LM2745/8 reference voltage of 0.6V. At this point the reference voltage takes over at the non-inverting error amplifier input. The capacitance of  $C_{SS}$  determines the length of the soft-start period, and can be approximated by:

$$C_{SS} = \frac{t_{SS}}{60}$$

Where  $C_{SS}$  is in  $\mu$ F and  $t_{SS}$  is in ms.

During soft start the Power Good flag is forced low and it is released when the FB pin voltage reaches 70% of 0.6V. At this point the chip enters normal operation mode, and the output overvoltage and undervoltage monitoring starts.

### SETTING THE OUTPUT VOLTAGE

The LM2745/8 regulates the output voltage by controlling the duty cycle of the high side and low side MOSFETs (see [Typical Application Circuit](#)). The equation governing output voltage is:

$$V_{OUT} = \frac{R_{FB1} + R_{FB2}}{R_{FB1}} V_{FB}$$

( $V_{FB} = 0.6V$ )

### SETTING THE SWITCHING FREQUENCY

During fixed-frequency mode of operation the PWM frequency is adjustable between 50 kHz and 1 MHz and is set by an external resistor,  $R_{FADJ}$ , between the FREQ/SYNC pin and ground. The resistance needed for a desired frequency is approximated by the curve FREQUENCY vs. FREQUENCY ADJUST RESISTOR in the [Typical Performance Characteristics](#) section.

When it is desired to synchronize the switching frequency with an external clock source, the LM2745 has the unique ability to synchronize from this external source within the range of 250 kHz to 1 MHz. The external clock signal should be AC coupled to the FREQ/SYNC pin as shown below in [Figure 17](#), where the  $R_{FADJ}$  is chosen so that the fixed frequency is approximately within  $\pm 30\%$  of the external synchronizing clock frequency. An internal protection diode clamps the low level of the synchronizing signal to approximately -0.5V. The internal clock synchronizes to the rising edge of the external clock.

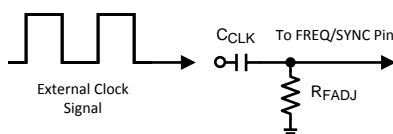

**Figure 17. AC Coupled Clock**

It is recommended to choose an AC coupling capacitance in the range of 50 pF to 100 pF. Exceeding the recommended capacitance may inject excessive energy through the internal clamping diode structure present on the FREQ/SYNC pin.

The typical trip level of the synchronization pin is 1.5V. To ensure proper synchronization and to avoid damaging the IC, the peak-to-peak value (amplitude) should be between 2.5V and  $V_{CC}$ . The minimum width of this pulse must be greater than 100 ns, and its maximum width must be 100ns less than the period of the switching cycle.

The external clock synchronization process begins once the LM2745 is enabled and an external clock signal is detected. During the external clock synchronization process the internal clock initially switches at approximately 1.5 MHz and decreases until it has matched the external clock's frequency. The lock-in period is approximately 30  $\mu$ s if the external clock is switching at 1 MHz, and about 100  $\mu$ s if the external clock is at 200 kHz. When there is no clock signal present, the LM2745 enters into fixed-frequency mode and begins switching at the frequency set by the  $R_{FADJ}$  resistor. If the external clock signal is removed after frequency synchronization, the LM2745 will enter fixed-frequency mode within two clock cycles. If the external clock is removed within the 30  $\mu$ s lock-in period, the LM2745 will re-enter fixed-frequency mode within two internal clock cycles after the lock-in period.

## OUTPUT PRE-BIAS STARTUP

If there is a pre-biased load on the output of the LM2745/8 during startup, the IC will disable switching of the low-side MOSFET and monitor the SW node voltage during the off-time of the high-side MOSFET. There is no load current sensing while in pre-bias mode because the low-side MOSFET never turns on. The IC will remain in this pre-bias mode until it sees the SW node stays below 0V during the entire high-side MOSFET's off-time. Once it is determined that the SW node remained below 0V during the high-side off-time, the low-side MOSFET begins switching during the next switching cycle. Figure 18 shows the SW node, HG, and LG signals during pre-bias startup. The pre-biased output voltage should not exceed  $V_{CC} + V_{GS}$  of the external High-Side MOSFET to ensure that the High-Side MOSFET will be able to switch during startup.

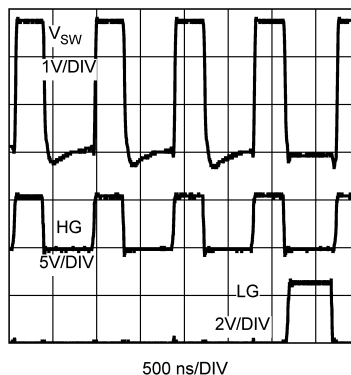

Figure 18. Output Pre-Bias Mode Waveforms

## TRACKING A VOLTAGE LEVEL

The LM2745/8 can track the output of a master power supply during soft-start by connecting a resistor divider to the SS/TRACK pin. In this way, the output voltage slew rate of the LM2745/8 will be controlled by the master supply for loads that require precise sequencing. When the tracking function is used no soft-start capacitor should be connected to the SS/TRACK pin. However in all other cases, a  $C_{SS}$  value of at least 1 nF between the soft-start pin and ground should be used.

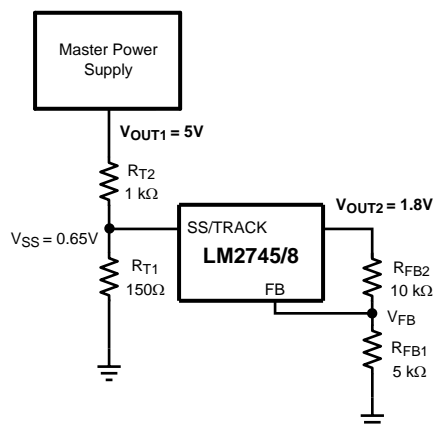

Figure 19. Tracking Circuit

One way to use the tracking feature is to design the tracking resistor divider so that the master supply's output voltage ( $V_{OUT1}$ ) and the LM2745/8's output voltage (represented symbolically in Figure 19 as  $V_{OUT2}$ , i.e. without explicitly showing the power components) both rise together and reach their target values at the same time. For this case, the equation governing the values of the tracking divider resistors  $R_{T1}$  and  $R_{T2}$  is:

$$0.65 = V_{OUT1} \frac{R_{T1}}{R_{T1} + R_{T2}}$$

The current through  $R_{T1}$  should be about 4 mA for precise tracking. The final voltage of the SS/TRACK pin should be set higher than the feedback voltage of 0.6V (say about 0.65V as in the above equation). If the master supply voltage was 5V and the LM2745/8 output voltage was 1.8V, for example, then the value of  $R_{T1}$  needed to give the two supplies identical soft-start times would be 150Ω. A timing diagram for the equal soft-start time case is shown in Figure 20.

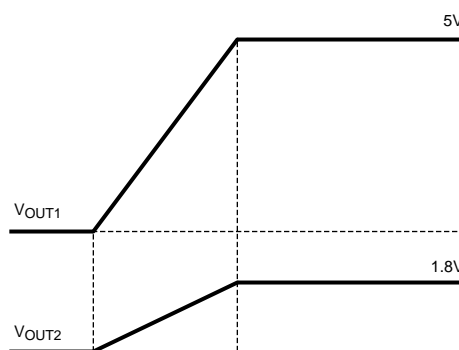

Figure 20. Tracking with Equal Soft-Start Time

### TRACKING A VOLTAGE SLEW RATE

The tracking feature can alternatively be used not to make both rails reach regulation at the same time but rather to have similar rise rates (in terms of output  $dV/dt$ ). This method ensures that the output voltage of the LM2745/8 always reaches regulation before the output voltage of the master supply. In this case, the tracking resistors can be determined based on the following equation:

$$0.65 = V_{OUT2} \frac{R_{T1}}{R_{T1} + R_{T2}}$$

For the example case of  $V_{OUT1} = 5V$  and  $V_{OUT2} = 1.8V$ , with  $R_{T1}$  set to  $150\Omega$  as before,  $R_{T2}$  is calculated from the above equation to be  $265\Omega$ . A timing diagram for the case of equal slew rates is shown in [Figure 21](#).

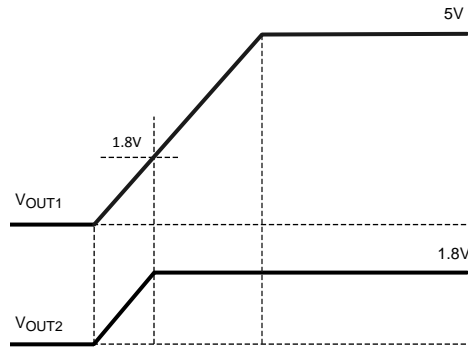

**Figure 21. Tracking with Equal Slew Rates**

## SEQUENCING

The start up/soft-start of the LM2745/8 can be delayed for the purpose of sequencing by connecting a resistor divider from the output of a master power supply to the  $\overline{SD}$  pin, as shown in [Figure 22](#).

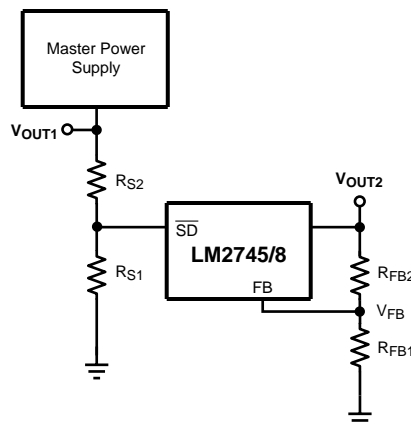

**Figure 22. Sequencing Circuit**

A desired delay time  $t_{DELAY}$  between the startup of the master supply output voltage and the LM2745/8 output voltage can be set based on the  $\overline{SD}$  pin low-to-high threshold  $V_{SD-IH}$  and the slew rate of the voltage at the  $\overline{SD}$  pin,  $SR_{SD}$ :

$$t_{DELAY} = V_{SD-IH} / SR_{SD}$$

Note again, that in [Figure 22](#), the LM2745/8's output voltage has been represented symbolically as  $V_{OUT2}$ , i.e. without explicitly showing the power components.

$V_{SD-IH}$  is typically  $1.08V$  and  $SR_{SD}$  is the slew rate of the  $\overline{SD}$  pin voltage. The values of the sequencing divider resistors  $R_{S1}$  and  $R_{S2}$  set the  $SR_{SD}$  based on the master supply output voltage slew rate,  $SR_{OUT1}$ , using the following equation:

$$SR_{SD} = SR_{OUT1} \frac{R_{S1}}{R_{S1} + R_{S2}}$$

For example, if the master supply output voltage slew rate was 1V/ms and the desired delay time between the startup of the master supply and LM2745/8 output voltage was 5 ms, then the desired  $\overline{SD}$  pin slew rate would be  $(1.08V/5\text{ ms}) = 0.216V/ms$ . Due to the internal impedance of the  $\overline{SD}$  pin, the maximum recommended value for  $R_{S2}$  is 1 k $\Omega$ . To achieve the desired slew rate,  $R_{S1}$  would then be 274 $\Omega$ . A timing diagram for this example is shown in Figure 23.

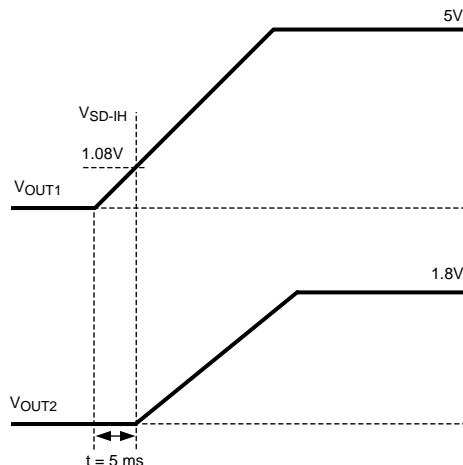

Figure 23. Delay for Sequencing

### $\overline{SD}$ PIN IMPEDANCE

When connecting a resistor divider to the  $\overline{SD}$  pin of the LM2745/8 some care has to be taken. Once the  $\overline{SD}$  voltage goes above  $V_{SD-IH}$ , a 17  $\mu A$  pull-up current is activated as shown in Figure 24. This current is used to create the internal hysteresis ( $\approx 170\text{ mV}$ ); however, high external impedances will affect the  $\overline{SD}$  pin logic thresholds as well. The external impedance used for the sequencing divider network should preferably be a small fraction of the impedance of the  $\overline{SD}$  pin for good performance (around 1 k $\Omega$ ).

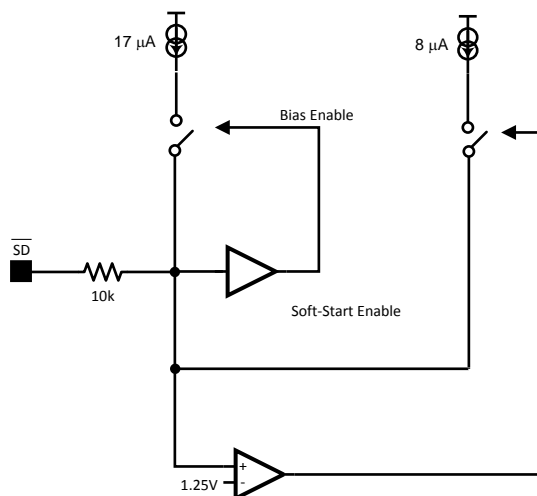

Figure 24.  $\overline{SD}$  Pin Logic

## MOSFET GATE DRIVERS

The LM2745/8 has two gate drivers designed for driving N-channel MOSFETs in a synchronous mode. Note that unlike most other synchronous controllers, the bootstrap capacitor of the LM2745/8 provides power not only to the driver of the upper MOSFET, but the lower MOSFET driver too (both drivers are ground referenced, i.e. no floating driver).

Two things must be kept in mind here. First, the BOOT pin has an absolute maximum rating of 18V. This must never be exceeded, even momentarily. Since the bootstrap capacitor is connected to the SW node, the peak voltage impressed on the BOOT pin is the sum of the input voltage ( $V_{IN}$ ) plus the voltage across the bootstrap capacitor (ignoring any forward drop across the bootstrap diode). The bootstrap capacitor is charged up by a given rail (called  $V_{BOOT\_DC}$  here) whenever the upper MOSFET turns off. This rail can be the same as  $V_{CC}$  or it can be any external ground-referenced DC rail. But care has to be exercised when choosing this bootstrap DC rail that the BOOT pin is not damaged. For example, if the desired maximum  $V_{IN}$  is 14V, and  $V_{BOOT\_DC}$  is chosen to be the same as  $V_{CC}$ , then clearly if the  $V_{CC}$  rail is 6V, the peak voltage on the BOOT pin is  $14V + 6V = 20V$ . This is unacceptable, as it is in excess of the rating of the BOOT pin. A  $V_{CC}$  of 3V would be acceptable in this case. Or the  $V_{IN}$  range must be reduced accordingly. There is also the option of deriving the bootstrap DC rail from another 3V external rail, independent of  $V_{CC}$ .

The second thing to be kept in mind here is that the output of the low-side driver swings between the bootstrap DC rail level of  $V_{BOOT\_DC}$  and Ground, whereas the output of the high-side driver swings between  $V_{IN} + V_{BOOT\_DC}$  and Ground. To keep the high-side MOSFET fully on when desired, the Gate pin voltage of the MOSFET must be higher than its instantaneous Source pin voltage by an amount equal to the 'Miller plateau'. It can be shown that this plateau is equal to the threshold voltage of the chosen MOSFET plus a small amount equal to  $I_o/g$ . Here  $I_o$  is the maximum load current of the application, and  $g$  is the transconductance of this MOSFET (typically about 100 for logic-level devices). That means we must choose  $V_{BOOT\_DC}$  to at least exceed the Miller plateau level. This may therefore affect the choice of the threshold voltage of the external MOSFETs, and that in turn may depend on the chosen  $V_{BOOT\_DC}$  rail.

So far, in the discussion above, the forward drop across the bootstrap diode has been ignored. But since that does affect the output of the driver somewhat, it is a good idea to include this drop in the following examples. Looking at the [Typical Application](#) schematic, this means that the difference voltage  $V_{CC} - V_{D1}$ , which is the voltage the bootstrap capacitor charges up to, must always be greater than the maximum tolerance limit of the threshold voltage of the upper MOSFET. Here  $V_{D1}$  is the forward voltage drop across the bootstrap diode D1. This may place restrictions on the minimum input voltage and/or type of MOSFET used.

A basic bootstrap circuit can be built using one Schottky diode and a small capacitor, as shown in [Figure 25](#). The capacitor  $C_{BOOT}$  serves to maintain enough voltage between the top MOSFET gate and source to control the device even when the top MOSFET is on and its source has risen up to the input voltage level. The charge pump circuitry is fed from  $V_{CC}$ , which can operate over a range from 3.0V to 6.0V. Using this basic method the voltage applied to the gates of both high-side and low-side MOSFETs is  $V_{CC} - V_D$ . This method works well when  $V_{CC}$  is  $5V \pm 10\%$ , because the gate drives will get at least 4.0V of drive voltage during the worst case of  $V_{CC\_MIN} = 4.5V$  and  $V_{D\_MAX} = 0.5V$ . Logic level MOSFETs generally specify their on-resistance at  $V_{GS} = 4.5V$ . When  $V_{CC} = 3.3V \pm 10\%$ , the gate drive at worst case could go as low as 2.5V. Logic level MOSFETs are not specified to turn on, or may have much higher on-resistance at 2.5V. Sub-logic level MOSFETs, usually specified at  $V_{GS} = 2.5V$ , will work, but are more expensive, and tend to have higher on-resistance. The circuit in [Figure 25](#) works well for input voltages ranging from 1V up to 14V and  $V_{CC} = 5V \pm 10\%$ , because the drive voltage depends only on  $V_{CC}$ .

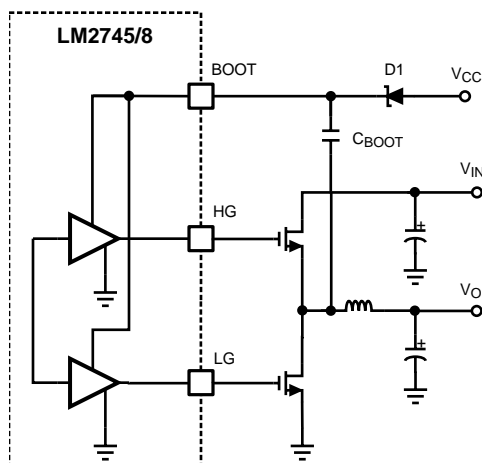

Figure 25. Basic Charge Pump (Bootstrap)

Note that the LM2745/8 can be paired with a low cost linear regulator like the LM78L05 to run from a single input rail between 6.0 and 14V. The 5V output of the linear regulator powers both the  $V_{CC}$  and the bootstrap circuit, providing efficient drive for logic level MOSFETs. An example of this circuit is shown in Figure 26.

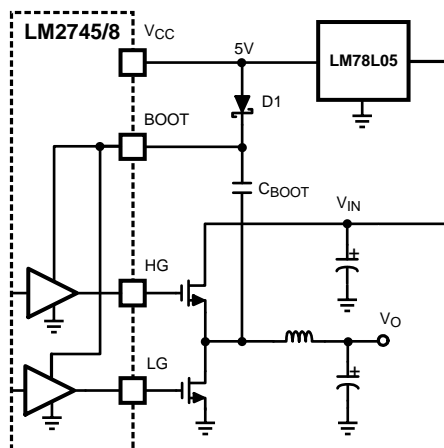
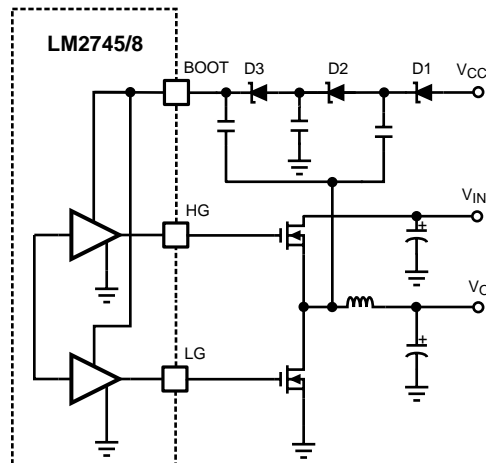

Figure 26. LM78L05 Feeding Basic Charge Pump

Figure 27 shows a second possibility for bootstrapping the MOSFET drives using a doubler. This circuit provides an equal voltage drive of  $V_{CC} - 3V_D + V_{IN}$  to both the high-side and low-side MOSFET drives. This method should only be used in circuits that use 3.3V for both  $V_{CC}$  and  $V_{IN}$ . Even with  $V_{IN} = V_{CC} = 3.0V$  (10% lower tolerance on 3.3V) and  $V_D = 0.5V$  both high-side and low-side gates will have at least 4.5V of drive. The power dissipation of the gate drive circuitry is directly proportional to gate drive voltage, hence the thermal limits of the LM2745/8 IC will quickly be reached if this circuit is used with  $V_{CC}$  or  $V_{IN}$  voltages over 5V.



**Figure 27. Charge Pump with Added Gate Drive**

All the gate drive circuits shown in the above figures typically use 100 nF ceramic capacitors in the bootstrap locations.

## POWER GOOD SIGNAL

The open drain output on the Power Good pin needs a pull-up resistor to a low voltage source. The pull-up resistor should be chosen so that the current going into the Power Good pin is less than 1 mA. A 100 kΩ resistor is recommended for most applications.

The Power Good signal is an OR-gated flag which takes into account both output overvoltage and undervoltage conditions. If the feedback pin (FB) voltage is 18% above its nominal value ( $118\% \times V_{FB} = 0.708V$ ) or falls 28% below that value ( $72\% \times V_{FB} = 0.42V$ ) the Power Good flag goes low. The Power Good flag can be used to signal other circuits that the output voltage has fallen out of regulation, however the switching of the LM2745/8 continues regardless of the state of the Power Good signal. The Power Good flag will return to logic high whenever the feedback pin voltage is between 72% and 118% of 0.6V.

## UVLO

The 2.79V turn-on threshold on  $V_{CC}$  has a built in hysteresis of about 300 mV. If  $V_{CC}$  drops below 2.42V, the chip definitely enters UVLO mode. UVLO consists of turning off the top and bottom MOSFETS and remaining in that condition until  $V_{CC}$  rises above 2.79V. As with normal shutdown initiated by the  $\overline{SD}$  pin, the soft-start capacitor is discharged through an internal MOSFET, ensuring that the next start-up will be controlled by the soft-start circuitry.

## CURRENT LIMIT

Current limit is realized by sensing the voltage across the low-side MOSFET while it is on. The  $R_{DS(on)}$  of the MOSFET is a known value; hence the current through the MOSFET can be determined as:

$$V_{DS} = I_{OUT} \times R_{DS(on)}$$

The current through the low-side MOSFET while it is on is also the falling portion of the inductor current. The current limit threshold is determined by an external resistor,  $R_{CS}$ , connected between the switching node and the  $I_{SEN}$  pin. A constant current ( $I_{SEN-TH}$ ) of 40  $\mu A$  typical is forced through  $R_{CS}$ , causing a fixed voltage drop. This fixed voltage is compared against  $V_{DS}$  and if the latter is higher, the current limit of the chip has been reached. To obtain a more accurate value for  $R_{CS}$  you must consider the operating values of  $R_{DS(on)}$  and  $I_{SEN-TH}$  at their operating temperatures in your application and the effect of slight parameter differences from part to part.  $R_{CS}$  can be found by using the following equation using the  $R_{DS(on)}$  value of the low side MOSFET at it's expected hot temperature and the absolute minimum value expected over the full temperature range for the for the  $I_{SEN-TH}$  which is 25  $\mu A$ :

$$R_{CS} = R_{DS(on)-HOT} \times I_{LIM} / I_{SEN-TH}$$

For example, a conservative 15A current limit in a 10A design with a  $R_{DS(on)-HOT}$  of 10 mΩ would require a 6 kΩ resistor. The minimum value for  $R_{CS}$  in any application is 1 kΩ. Because current sensing is done across the low-side MOSFET, no minimum high-side on-time is necessary. The LM2745/8 enters current limit mode if the inductor current exceeds the current limit threshold at the point where the high-side MOSFET turns off and the low-side MOSFET turns on. (The point of peak inductor current, see [Figure 28](#)). Note that in normal operation mode the high-side MOSFET always turns on at the beginning of a clock cycle. In current limit mode, by contrast, the high-side MOSFET on-pulse is skipped. This causes inductor current to fall. Unlike a normal operation switching cycle, however, in a current limit mode switching cycle the high-side MOSFET will turn on as soon as inductor current has fallen to the current limit threshold. The LM2745/8 will continue to skip high-side MOSFET pulses until the inductor current peak is below the current limit threshold, at which point the system resumes normal operation.

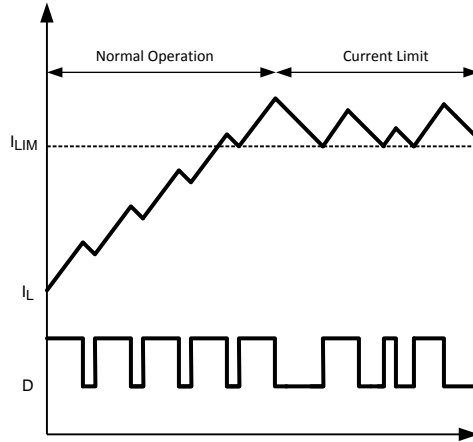

**Figure 28. Current Limit Threshold**

Unlike a high-side MOSFET current sensing scheme, which limits the peaks of inductor current, low-side current sensing is only allowed to limit the current during the converter off-time, when inductor current is falling. Therefore in a typical current limit plot the valleys are normally well defined, but the peaks are variable, according to the duty cycle. The PWM error amplifier and comparator control the off-pulse of the high-side MOSFET, even during current limit mode, meaning that peak inductor current can exceed the current limit threshold. Assuming that the output inductor does not saturate, the maximum peak inductor current during current limit mode can be calculated with the following equation:

$$I_{PK-CL} = I_{LIM} + (T_{SW} - 200 \text{ ns}) \frac{V_{IN} - V_O}{L}$$

Where  $T_{SW}$  is the inverse of switching frequency  $f_{SW}$ . The 200 ns term represents the minimum off-time of the duty cycle, which ensures enough time for correct operation of the current sensing circuitry.

In order to minimize the time period in which peak inductor current exceeds the current limit threshold, the IC also discharges the soft-start capacitor through a fixed 90 μA sink. The output of the LM2745/8 internal error amplifier is limited by the voltage on the soft-start capacitor. Hence, discharging the soft-start capacitor reduces the maximum duty cycle  $D$  of the controller. During severe current limit this reduction in duty cycle will reduce the output voltage if the current limit conditions last for an extended time. Output inductor current will be reduced in turn to a flat level equal to the current limit threshold. The third benefit of the soft-start capacitor discharge is a smooth, controlled ramp of output voltage when the current limit condition is cleared.

## SHUTDOWN

If the shutdown pin is pulled low, (below 0.8V) the LM2745/8 enters shutdown mode, and discharges the soft-start capacitor through a MOSFET switch. The high and low-side MOSFETs are turned off. The LM2745/8 remains in this state as long as  $V_{SD}$  sees a logic low (see the [Electrical Characteristics](#) table). To assure proper IC start-up the shutdown pin should not be left floating. For normal operation this pin should be connected directly to  $V_{CC}$  or to another voltage between 1.3V to  $V_{CC}$  (see the [Electrical Characteristics](#) table).

## DESIGN CONSIDERATIONS

The following is a design procedure for all the components needed to create the [Typical Application Circuit](#). This design converts 3.3V ( $V_{IN}$ ) to 1.2V ( $V_{OUT}$ ) at a maximum load of 4A with an efficiency of 89% and a switching frequency of 300 kHz. The same procedures can be followed to create many other designs with varying input voltages, output voltages, and load currents.

### Input Capacitor

The input capacitors in a Buck converter are subjected to high stress due to the input current trapezoidal waveform. Input capacitors are selected for their ripple current capability and their ability to withstand the heat generated since that ripple current passes through their ESR. Input rms ripple current is approximately:

$$I_{RMS\_RIP} = I_{OUT} \times \sqrt{D(1 - D)}$$

Where duty cycle  $D = V_{OUT}/V_{IN}$ .

The power dissipated by each input capacitor is:

$$P_{CAP} = \frac{(I_{RMS\_RIP})^2 \times ESR}{n^2}$$

where  $n$  is the number of paralleled capacitors, and ESR is the equivalent series resistance of each capacitor. The equation above indicates that power loss in each capacitor decreases rapidly as the number of input capacitors increases. The worst-case ripple for a Buck converter occurs during full load and when the duty cycle ( $D$ ) is 0.5. For this 3.3V to 1.2V design the duty cycle is 0.364. For a 4A maximum load the ripple current is 1.92A.

### Output Inductor

The output inductor forms the first half of the power stage in a Buck converter. It is responsible for smoothing the square wave created by the switching action and for controlling the output current ripple ( $\Delta I_{OUT}$ ). The inductance is chosen by selecting between tradeoffs in efficiency and response time. The smaller the output inductor, the more quickly the converter can respond to transients in the load current. However, as shown in the efficiency calculations, a smaller inductor requires a higher switching frequency to maintain the same level of output current ripple. An increase in frequency can mean increasing loss in the MOSFETs due to the charging and discharging of the gates. Generally the switching frequency is chosen so that conduction loss outweighs switching loss. The equation for output inductor selection is:

$$L = \frac{V_{IN} - V_{OUT}}{\Delta I_{OUT} \times f_{SW}} \times D$$

$$L = \frac{3.3V - 1.2V}{0.4 \times 4A \times 300 \text{ kHz}} \times \frac{1.2V}{3.3V}$$

$$L = 1.6 \mu\text{H}$$

Here we have plugged in the values for output current ripple, input voltage, output voltage, switching frequency, and assumed a 40% peak-to-peak output current ripple. This yields an inductance of 1.6  $\mu\text{H}$ . The output inductor must be rated to handle the peak current (also equal to the peak switch current), which is ( $I_{OUT} + (0.5 \times \Delta I_{OUT})$ ) = 4.8A, for a 4A design.

The Coilcraft DO3316P-222P is 2.2  $\mu\text{H}$ , is rated to 7.4A peak, and has a direct current resistance (DCR) of 12 m $\Omega$ . After selecting the Coilcraft DO3316P-222P for the output inductor, actual inductor current ripple should be re-calculated with the selected inductance value, as this information is needed to select the output capacitor. Re-arranging the equation used to select inductance yields the following:

$$\Delta I_{OUT} = \frac{V_{IN(MAX)} - V_O}{f_{SW} \times L_{ACTUAL}} \times D$$

$V_{IN(MAX)}$  is assumed to be 10% above the steady state input voltage, or 3.6V at  $V_{IN} = 3.3V$ . The re-calculated current ripple will then be 1.2A. This gives a peak inductor/switch current will be 4.6A.

## Output Capacitor

The output capacitor forms the second half of the power stage of a Buck switching converter. It is used to control the output voltage ripple ( $\Delta V_{OUT}$ ) and to supply load current during fast load transients.

In this example the output current is 4A and the expected type of capacitor is an aluminum electrolytic, as with the input capacitors. Other possibilities include ceramic, tantalum, and solid electrolyte capacitors, however the ceramic type often do not have the large capacitance needed to supply current for load transients, and tantalums tend to be more expensive than aluminum electrolytic. Aluminum capacitors tend to have very high capacitance and fairly low ESR, meaning that the ESR zero, which affects system stability, will be much lower than the switching frequency. The large capacitance means that at the switching frequency, the ESR is dominant, hence the type and number of output capacitors is selected on the basis of ESR. One simple formula to find the maximum ESR based on the desired output voltage ripple,  $\Delta V_{OUT}$  and the designed output current ripple,  $\Delta I_{OUT}$ , is:

$$ESR_{MAX} = \frac{\Delta V_{OUT}}{\Delta I_{OUT}}$$

In this example, in order to maintain a 2% peak-to-peak output voltage ripple and a 40% peak-to-peak inductor current ripple, the required maximum ESR is 20 m $\Omega$ . The Sanyo 4SP560M electrolytic capacitor will give an equivalent ESR of 14 m $\Omega$ . The capacitance of 560  $\mu$ F is enough to supply energy even to meet severe load transient demands.

## MOSFETs

Selection of the power MOSFETs is governed by a trade-off between cost, size, and efficiency. One method is to determine the maximum cost that can be endured, and then select the most efficient device that fits that price. Breaking down the losses in the high-side and low-side MOSFETs and then creating spreadsheets is one way to determine relative efficiencies between different MOSFETs. Good correlation between the prediction and the bench result is not specified, however. Single-channel buck regulators that use a controller IC and discrete MOSFETs tend to be most efficient for output currents of 2 to 10A.

Losses in the high-side MOSFET can be broken down into conduction loss, gate charging loss, and switching loss. Conduction, or  $I^2R$  loss, is approximately:

$$P_C = D (I_O^2 \times R_{DSON-HI} \times 1.3) \text{ (High-Side MOSFET)}$$

$$P_C = (1 - D) \times (I_O^2 \times R_{DSON-LO} \times 1.3) \text{ (Low-Side MOSFET)}$$

In the above equations the factor 1.3 accounts for the increase in MOSFET  $R_{DSON}$  due to heating. Alternatively, the 1.3 can be ignored and the  $R_{DSON}$  of the MOSFET estimated using the  $R_{DSON}$  Vs. Temperature curves in the MOSFET datasheets.

Gate charging loss results from the current driving the gate capacitance of the power MOSFETs, and is approximated as:

$$P_{GC} = n \times (V_{DD}) \times Q_G \times f_{SW}$$

where 'n' is the number of MOSFETs (if multiple devices have been placed in parallel),  $V_{DD}$  is the driving voltage (see [MOSFET Gate Drivers](#) section) and  $Q_{GS}$  is the gate charge of the MOSFET. If different types of MOSFETs are used, the 'n' term can be ignored and their gate charges simply summed to form a cumulative  $Q_G$ . Gate charge loss differs from conduction and switching losses in that the actual dissipation occurs in the LM2745/8, and not in the MOSFET itself.

Switching loss occurs during the brief transition period as the high-side MOSFET turns on and off, during which both current and voltage are present in the channel of the MOSFET. It can be approximated as:

$$P_{SW} = 0.5 \times V_{IN} \times I_O \times (t_r + t_f) \times f_{SW}$$

where  $t_r$  and  $t_f$  are the rise and fall times of the MOSFET. Switching loss occurs in the high-side MOSFET only.

For this example, the maximum drain-to-source voltage applied to either MOSFET is 3.6V. The maximum drive voltage at the gate of the high-side MOSFET is 3.1V, and the maximum drive voltage for the low-side MOSFET is 3.3V. Due to the low drive voltages in this example, a MOSFET that turns on fully with 3.1V of gate drive is needed. For designs of 5A and under, dual MOSFETs in SO-8 provide a good trade-off between size, cost, and efficiency.

## Support Components

**C<sub>IN2</sub>** - A small (0.1 to 1  $\mu\text{F}$ ) ceramic capacitor should be placed as close as possible to the drain of the high-side MOSFET and source of the low-side MOSFET (dual MOSFETs make this easy). This capacitor should be X5R type dielectric or better.

**R<sub>CC</sub>, C<sub>CC</sub>**- These are standard filter components designed to ensure smooth DC voltage for the chip supply. R<sub>CC</sub> should be 1 to 10 $\Omega$ . C<sub>CC</sub> should 1  $\mu\text{F}$ , X5R type or better.

**C<sub>BOOT</sub>**- Bootstrap capacitor, typically 100 nF.

**R<sub>PULL-UP</sub>** – This is a standard pull-up resistor for the open-drain power good signal (PWGD). The recommended value is 100 k $\Omega$  connected to V<sub>CC</sub>. If this feature is not necessary, the resistor can be omitted.

**D<sub>1</sub>** - A small Schottky diode should be used for the bootstrap. It allows for a minimum drop for both high and low-side drivers. The MBR0520 or BAT54 work well in most designs.

**R<sub>CS</sub>** - Resistor used to set the current limit. Since the design calls for a peak current magnitude ( $I_{\text{OUT}} + (0.5 \times \Delta I_{\text{OUT}})$ ) of 4.8A, a safe setting would be 6A. (This is below the saturation current of the output inductor, which is 7A.) Following the equation from the [Current Limit](#) section, a 1.3 k $\Omega$  resistor should be used.

**R<sub>FADJ</sub>** - This resistor is used to set the switching frequency of the chip. The resistor value is approximated from the *Frequency vs Frequency Adjust Resistor* curve in the [Typical Performance Characteristics](#) section. For 300 kHz operation, a 100 k $\Omega$  resistor should be used.

**C<sub>SS</sub>** - The soft-start capacitor depends on the user requirements and is calculated based on the equation given in the section titled [START UP/SOFT-START](#). Therefore, for a 7 ms delay, a 12 nF capacitor is suitable.

## Control Loop Compensation

The LM2745/8 uses voltage-mode ('VM') PWM control to correct changes in output voltage due to line and load transients. VM requires careful small signal compensation of the control loop for achieving high bandwidth and good phase margin.

The control loop is comprised of two parts. The first is the power stage, which consists of the duty cycle modulator, output inductor, output capacitor, and load. The second part is the error amplifier, which for the LM2745/8 is a 9 MHz op-amp used in the classic inverting configuration. [Figure 29](#) shows the regulator and control loop components.

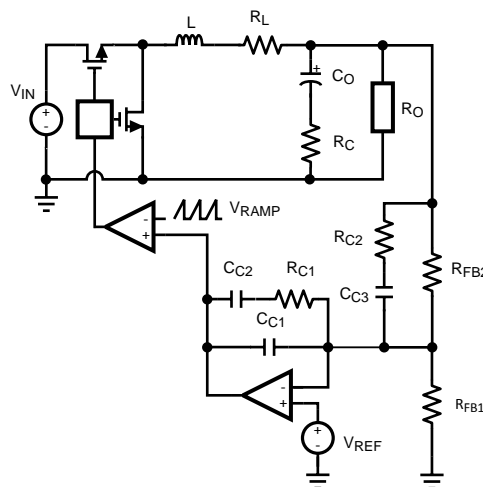

**Figure 29. Power Stage and Error Amp**

One popular method for selecting the compensation components is to create Bode plots of gain and phase for the power stage and error amplifier. Combined, they make the overall bandwidth and phase margin of the regulator easy to see. Software tools such as Excel, MathCAD, and Matlab are useful for showing how changes in compensation or the power stage affect system gain and phase.

The power stage modulator provides a DC gain  $A_{DC}$  that is equal to the input voltage divided by the peak-to-peak value of the PWM ramp. This ramp is  $1.0V_{pk-pk}$  for the LM2745/8. The inductor and output capacitor create a double pole at frequency  $f_{DP}$ , and the capacitor ESR and capacitance create a single zero at frequency  $f_{ESR}$ . For this example, with  $V_{IN} = 3.3V$ , these quantities are:

$$A_{DC} = \frac{V_{IN}}{V_{RAMP}} = \frac{3.3}{1.0} = 10.4 \text{ dB}$$

$$f_{DP} = \frac{1}{2\pi} \sqrt{\frac{R_O + R_L}{LC_O(R_O + ESR)}} = 4.5 \text{ kHz}$$

$$f_{ESR} = \frac{1}{2\pi C_O ESR} = 20.3 \text{ kHz}$$

In the equation for  $f_{DP}$ , the variable  $R_L$  is the power stage resistance, and represents the inductor DCR plus the on resistance of the top power MOSFET.  $R_O$  is the output voltage divided by output current. The power stage transfer function  $G_{PS}$  is given by the following equation, and **Figure 30** shows Bode plots of the phase and gain in this example.

$$G_{PS} = \frac{V_{IN} \times R_O}{V_{RAMP}} \times \frac{sC_O R_C + 1}{as^2 + bs + c}$$

$$a = LC_O(R_O + R_C)$$

$$b = L + C_O(R_O R_L + R_O R_C + R_C R_L)$$

$$c = R_O + R_L$$

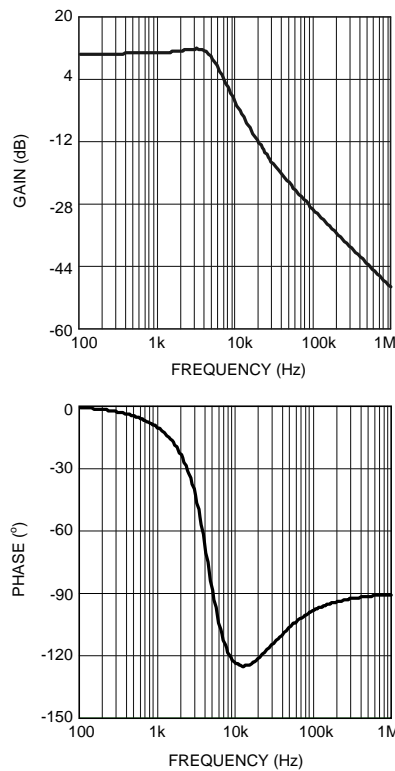

**Figure 30. Power Stage Gain and Phase**

The double pole at 4.5 kHz causes the phase to drop to approximately  $-130^\circ$  at around 10 kHz. The ESR zero, at 20.3 kHz, provides a  $+90^\circ$  boost that prevents the phase from dropping to  $-180^\circ$ . If this loop were left uncompensated, the bandwidth would be approximately 10 kHz and the phase margin  $53^\circ$ . In theory, the loop would be stable, but would suffer from poor DC regulation (due to the low DC gain) and would be slow to respond to load transients (due to the low bandwidth.) In practice, the loop could easily become unstable due to tolerances in the output inductor, capacitor, or changes in output current, or input voltage. Therefore, the loop is compensated using the error amplifier and a few passive components.

For this example, a Type III, or three-pole-two-zero approach gives optimal bandwidth and phase.

In most voltage mode compensation schemes, including Type III, a single pole is placed at the origin to boost DC gain as high as possible. Two zeroes  $f_{z1}$  and  $f_{z2}$  are placed at the double pole frequency to cancel the double pole phase lag. Then, a pole,  $f_{p1}$  is placed at the frequency of the ESR zero. A final pole  $f_{p2}$  is placed at one-half of the switching frequency. The gain of the error amplifier transfer function is selected to give the best bandwidth possible without violating the Nyquist stability criteria. In practice, a good crossover point is one-fifth of the switching frequency, or 60 kHz for this example. The generic equation for the error amplifier transfer function is:

$$G_{EA} = A_{EA} \times \frac{\left(\frac{s}{2\pi f_{z1}} + 1\right)\left(\frac{s}{2\pi f_{z2}} + 1\right)}{s\left(\frac{s}{2\pi f_{p1}} + 1\right)\left(\frac{s}{2\pi f_{p2}} + 1\right)}$$

In this equation the variable  $A_{EA}$  is a ratio of the values of the capacitance and resistance of the compensation components, arranged as shown in [Figure 29](#).  $A_{EA}$  is selected to provide the desired bandwidth. A starting value of 80,000 for  $A_{EA}$  should give a conservative bandwidth. Increasing the value will increase the bandwidth, but will also decrease phase margin. Designs with  $45\text{--}60^\circ$  are usually best because they represent a good trade-off between bandwidth and phase margin. In general, phase margin is lowest and gain highest (worst-case) for maximum input voltage and minimum output current. One method to select  $A_{EA}$  is to use an iterative process beginning with these worst-case conditions.

1. Increase  $A_{EA}$
2. Check overall bandwidth and phase margin
3. Change  $V_{IN}$  to minimum and recheck overall bandwidth and phase margin
4. Change  $I_O$  to maximum and recheck overall bandwidth and phase margin

The process ends when the both bandwidth and the phase margin are sufficiently high. For this example input voltage can vary from 3.0 to 3.6V and output current can vary from 0 to 4A, and after a few iterations a moderate gain factor of 101dB is used.

The error amplifier of the LM2745/8 has a unity-gain bandwidth of 9 MHz. In order to model the effect of this limitation, the open-loop gain can be calculated as:

$$OPG = \frac{2\pi \times 9 \text{ MHz}}{s}$$

The new error amplifier transfer function that takes into account unity-gain bandwidth is:

$$H_{EA} = \frac{G_{EA} \times OPG}{1 + G_{EA} + OPG}$$

The gain and phase of the error amplifier are shown in [Figure 31](#).

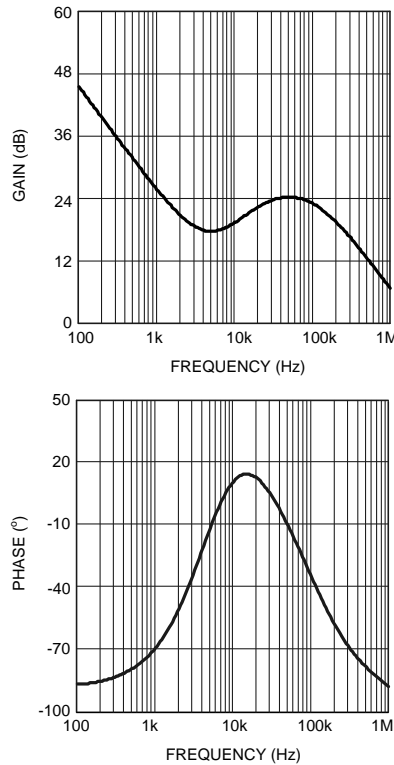

**Figure 31. Error Amp. Gain and Phase**

In VM regulators, the top feedback resistor  $R_{FB2}$  forms a part of the compensation. Setting  $R_{FB2}$  to  $10\text{ k}\Omega \pm 1\%$ , usually gives values for the other compensation resistors and capacitors that fall within a reasonable range. (Capacitances  $> 1\text{ pF}$ , resistances  $< 1\text{ M}\Omega$ )  $C_{C1}$ ,  $C_{C2}$ ,  $C_{C3}$ ,  $R_{C1}$ , and  $R_{C2}$  are selected to provide the poles and zeroes at the desired frequencies, using the following equations:

$$C_{C1} = \frac{f_{Z1}}{A_{EA} \times 10,000 \times f_{P2}} = 27\text{ pF}$$

$$C_{C2} = \frac{1}{A_{EA} \times 10,000} - C_{C1} = 882\text{ pF}$$

$$C_{C3} = \frac{1}{2\pi \times 10,000} \times \left( \frac{1}{f_{Z2}} - \frac{1}{f_{P1}} \right) = 2.73\text{ nF}$$

$$R_{C1} = \frac{1}{2\pi \times C_{C2} \times f_{Z1}} = 39.8\text{ k}\Omega$$

$$R_{C2} = \frac{1}{2\pi \times C_{C3} \times f_{P1}} = 2.55\text{ k}\Omega$$

In practice, a good trade off between phase margin and bandwidth can be obtained by selecting the closest  $\pm 10\%$  capacitor values above what are suggested for  $C_{C1}$  and  $C_{C2}$ , the closest  $\pm 10\%$  capacitor value below the suggestion for  $C_{C3}$ , and the closest  $\pm 1\%$  resistor values below the suggestions for  $R_{C1}$ ,  $R_{C2}$ . Note that if the suggested value for  $R_{C2}$  is less than  $100\Omega$ , it should be replaced by a short circuit. Following this guideline, the compensation components will be:

$$C_{C1} = 27\text{ pF} \pm 10\%, C_{C2} = 820\text{ pF} \pm 10\%$$

$$C_{C3} = 2.7 \text{ nF} \pm 10\%, R_{C1} = 39.2 \text{ k}\Omega \pm 1\%$$

$$R_{C2} = 2.55 \text{ k}\Omega \pm 1\%$$

The transfer function of the compensation block can be derived by considering the compensation components as impedance blocks  $Z_F$  and  $Z_1$  around an inverting op-amp:

$$G_{EA-ACTUAL} = \frac{Z_F}{Z_1}$$

$$Z_F = \frac{\frac{1}{sC_{C1}} \times \left(10,000 + \frac{1}{sC_{C2}}\right)}{10,000 + \frac{1}{sC_{C1}} + \frac{1}{sC_{C2}}}$$

$$Z_1 = \frac{R_{C1} \left(R_{C2} + \frac{1}{sC_{C3}}\right)}{R_{C1} + R_{C2} + \frac{1}{sC_{C3}}}$$

As with the generic equation,  $G_{EA-ACTUAL}$  must be modified to take into account the limited bandwidth of the error amplifier. The result is:

$$H_{EA} = \frac{G_{EA-ACTUAL} \times OPG}{1 + G_{EA-ACTUAL} + OPG}$$

The total control loop transfer function  $H$  is equal to the power stage transfer function multiplied by the error amplifier transfer function.

$$H = G_{PS} \times H_{EA}$$

The bandwidth and phase margin can be read graphically from Bode plots of  $H_{EA}$  as shown in [Figure 32](#).

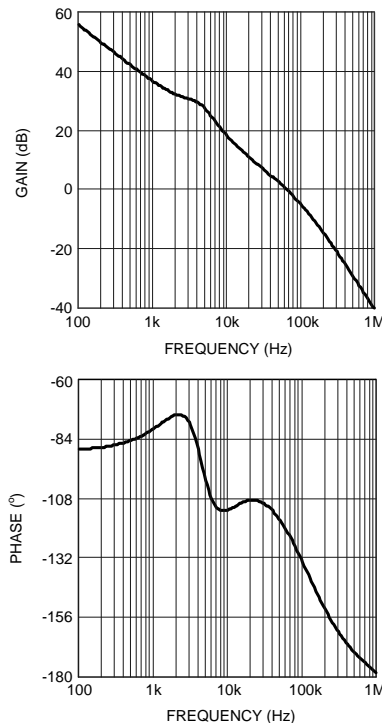

**Figure 32. Overall Loop Gain and Phase**

The bandwidth of this example circuit is 59 kHz, with a phase margin of 60°.

## EFFICIENCY CALCULATIONS

The following is a sample calculation.

A reasonable estimation of the efficiency of a switching buck controller can be obtained by adding together the Output Power ( $P_{OUT}$ ) loss and the Total Power ( $P_{TOTAL}$ ) loss:

$$\eta = \frac{P_{OUT}}{P_{OUT} + P_{TOTAL}} \times 100\%$$

The Output Power ( $P_{OUT}$ ) for the Typical Application Circuit design is (1.2V x 4A) = 4.8W. The Total Power ( $P_{TOTAL}$ ), with an efficiency calculation to complement the design, is shown below.

The majority of the power losses are due to the low side and high side MOSFET's losses. The losses in any MOSFET are group of switching ( $P_{SW}$ ) and conduction losses ( $P_{CND}$ ).

$$P_{FET} = P_{SW} + P_{CND} = 61.38 \text{ mW} + 270.42 \text{ mW}$$

$$P_{FET} = 331.8 \text{ mW}$$

### FET Switching Loss ( $P_{SW}$ )

$$P_{SW} = P_{SW(ON)} + P_{SW(OFF)}$$

$$P_{SW} = 0.5 \times V_{IN} \times I_{OUT} \times (t_r + t_f) \times f_{SW}$$

$$P_{SW} = 0.5 \times 3.3\text{V} \times 4\text{A} \times 300 \text{ kHz} \times 31 \text{ ns}$$

$$P_{SW} = 61.38 \text{ mW}$$

The FDS6898A has a typical turn-on rise time  $t_r$  and turn-off fall time  $t_f$  of 15 ns and 16 ns, respectively. The switching losses for this type of dual N-Channel MOSFETs are 0.061W.

### FET Conduction Loss ( $P_{CND}$ )

$$P_{CND} = P_{CND1} + P_{CND2}$$

$$P_{CND1} = I_{OUT}^2 \times R_{DS(ON)} \times k \times D$$

$$P_{CND2} = I_{OUT}^2 \times R_{DS(ON)} \times k \times (1-D)$$

$R_{DS(ON)} = 13 \text{ m}\Omega$  and the factor is a constant value ( $k = 1.3$ ) to account for the increasing  $R_{DS(ON)}$  of a FET due to heating.

$$P_{CND1} = (4\text{A})^2 \times 13 \text{ m}\Omega \times 1.3 \times 0.364$$

$$P_{CND2} = (4\text{A})^2 \times 13 \text{ m}\Omega \times 1.3 \times (1 - 0.364)$$

$$P_{CND} = 98.42 \text{ mW} + 172 \text{ mW} = 270.42 \text{ mW}$$

There are few additional losses that are taken into account:

### IC Operating Loss ( $P_{IC}$ )

$$P_{IC} = I_{Q-VCC} \times V_{CC}$$

where  $I_{Q-VCC}$  is the typical operating  $V_{CC}$  current

$$P_{IC} = 1.7 \text{ mA} \times 3.3\text{V} = 5.61 \text{ mW}$$

### FET Gate Charging Loss ( $P_{GATE}$ )

$$P_{GATE} = n \times V_{CC} \times Q_{GS} \times f_{SW}$$

$$P_{GATE} = 2 \times 3.3\text{V} \times 3 \text{ nC} \times 300 \text{ kHz}$$

$$P_{GATE} = 5.94 \text{ mW}$$

The value  $n$  is the total number of FETs used and  $Q_{GS}$  is the typical gate-source charge value, which is 3 nC. For the FDS6898A the gate charging loss is 5.94 mW.

### Input Capacitor Loss ( $P_{CAP}$ )

$$P_{CAP} = \frac{(I_{RMS\_RIP})^2 \times ESR}{n^2}$$

where,

$$I_{RMS\_RIP} = I_{OUT} \times \sqrt{D(1 - D)}$$

Here n is the number of paralleled capacitors, ESR is the equivalent series resistance of each, and P<sub>CAP</sub> is the dissipation in each. So for example if we use only one input capacitor of 24 mΩ.

$$P_{CAP} = \frac{(1.924A)^2 \times 24 \text{ m}\Omega}{1^2}$$

$$P_{CAP} = 88.8 \text{ mW}$$

**Output Inductor Loss (P<sub>IND</sub>)**

$$P_{IND} = I_{OUT}^2 \times DCR$$

where DCR is the DC resistance. Therefore, for example

$$P_{IND} = (4A)^2 \times 11 \text{ m}\Omega$$

$$P_{IND} = 176 \text{ mW}$$

**Total System Efficiency**

$$P_{TOTAL} = P_{FET} + P_{IC} + P_{GATE} + P_{CAP} + P_{IND}$$

$$\eta = \frac{P_{OUT}}{P_{OUT} + P_{TOTAL}} \times 100\%$$

$$\eta = \frac{4.8W}{4.8W + 0.6W} = 89\%$$

**Example Circuits**

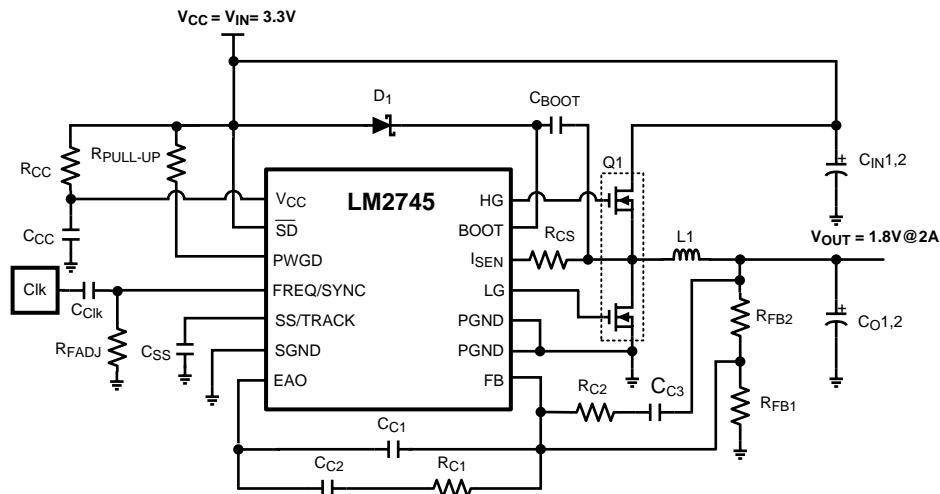

Figure 33. 3.3V to 1.8V @ 2A, f<sub>SW</sub> = 300 kHz

PART	PART NUMBER	TYPE	PACKAGE	DESCRIPTION	VENDOR
U1	LM2745	Synchronous Controller	TSSOP-14		TI
Q1	FDS6898A	Dual N-MOSFET	SO-8	20V, 10 mΩ @ 4.5V, 16nC	Fairchild
D1	MBR0520LT1	Schottky Diode	SOD-123		
L1	DO3316P-472	Inductor		4.7 μH, 4.8Arms 18 mΩ	Coilcraft
C <sub>IN1</sub>	16SP100M	Aluminum Electrolytic	10mm x 6mm	100 μF, 16V, 2.89Arms	Sanyo
C <sub>O1</sub>	6SP220M	Aluminum Electrolytic	10mm x 6mm	220 μF, 6.3V 3.1Arms	Sanyo
C <sub>CC</sub> , C <sub>BOOT</sub> , C <sub>IN2</sub> , C <sub>O2</sub>	VJ1206Y104KXXA	Capacitor	1206	0.1 μF, 10%	Vishay
C <sub>C3</sub>	VJ0805Y332KXXA	Capacitor	805	3300 pF, 10%	Vishay
C <sub>SS</sub>	VJ0805A123KXAA	Capacitor	805	12 nF, 10%	Vishay
C <sub>C2</sub>	VJ0805A821KXAA	Capacitor	805	820 pF 10%	Vishay
C <sub>C1</sub>	VJ0805A220KXAA	Capacitor	805	22 pF, 10%	Vishay
R <sub>FB2</sub>	CRCW08051002F	Resistor	805	10.0 kΩ 1%	Vishay
R <sub>FB1</sub>	CRCW08054991F	Resistor	805	4.99 kΩ 1%	Vishay
R <sub>FADJ</sub>	CRCW08051003F	Resistor	805	100 kΩ 1%	Vishay
R <sub>C2</sub>	CRCW08052101F	Resistor	805	2.1 kΩ 1%	Vishay
R <sub>CS</sub>	CRCW08052101F	Resistor	805	2.1 kΩ 1%	Vishay
R <sub>CC</sub>	CRCW080510R0F	Resistor	805	10.0Ω 1%	Vishay
R <sub>C1</sub>	CRCW08055492F	Resistor	805	54.9 kΩ 1%	Vishay
R <sub>PULL-UP</sub>	CRCW08051003J	Resistor	805	100 kΩ 5%	Vishay
C <sub>CLK</sub>	VJ0805A560KXAA	Capacitor	805	56 pF, 10%	Vishay

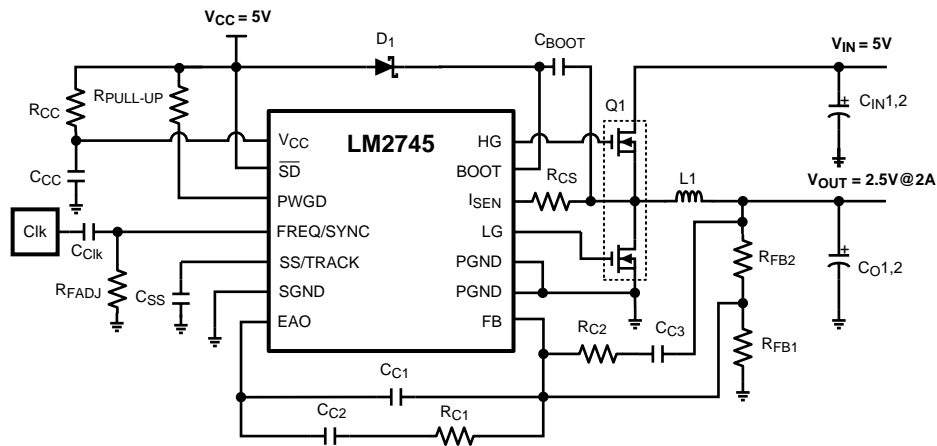

Figure 34. 5V to 2.5V @ 2A,  $f_{SW} = 300$  kHz

PART	PART NUMBER	TYPE	PACKAGE	DESCRIPTION	VENDOR
U1	LM2745	Synchronous Controller	TSSOP-14		TI
Q1	FDS6898A	Dual N-MOSFET	SO-8	20V, 10 mΩ @ 4.5V, 16 nC	Fairchild
D1	MBR0520LTI	Schottky Diode	SOD-123		
L1	DO3316P-682	Inductor		6.8 μH, 4.4Arms, 27 mΩ	Coilcraft
C <sub>IN1</sub>	16SP100M	Aluminum Electrolytic	10mm x 6mm	100 μF, 16V, 2.89Arms	Sanyo
C <sub>O1</sub>	10SP56M	Aluminum Electrolytic	6.3mm x 6mm	56 μF, 10V 1.7Arms	Sanyo
C <sub>CC</sub> , C <sub>BOOT</sub> , C <sub>IN2</sub> , C <sub>O2</sub>	VJ1206Y104KXXA	Capacitor	1206	0.1 μF, 10%	Vishay
C <sub>C3</sub>	VJ0805Y182KXXA	Capacitor	805	1800 pF, 10%	Vishay
C <sub>SS</sub>	VJ0805A123KXAA	Capacitor	805	12 nF, 10%	Vishay
C <sub>C2</sub>	VJ0805A821KXAA	Capacitor	805	820 pF 10%	Vishay
C <sub>C1</sub>	VJ0805A330KXAA	Capacitor	805	33 pF, 10%	Vishay
R <sub>FB2</sub>	CRCW08051002F	Resistor	805	10.0 kΩ 1%	Vishay
R <sub>FB1</sub>	CRCW08053161F	Resistor	805	3.16 kΩ 1%	Vishay
R <sub>FADJ</sub>	CRCW08051003F	Resistor	805	100 kΩ 1%	Vishay
R <sub>C2</sub>	CRCW08051301F	Resistor	805	1.3 kΩ 1%	Vishay
R <sub>CS</sub>	CRCW08052101F	Resistor	805	2.1 kΩ 1%	Vishay
R <sub>CC</sub>	CRCW080510R0F	Resistor	805	10.0Ω 1%	Vishay
R <sub>C1</sub>	CRCW08053322F	Resistor	805	33.2 kΩ 1%	Vishay
R <sub>PULL-UP</sub>	CRCW08051003J	Resistor	805	100 kΩ 5%	Vishay
C <sub>CLK</sub>	VJ0805A560KXAA	Capacitor	805	56 pF, 10%	Vishay

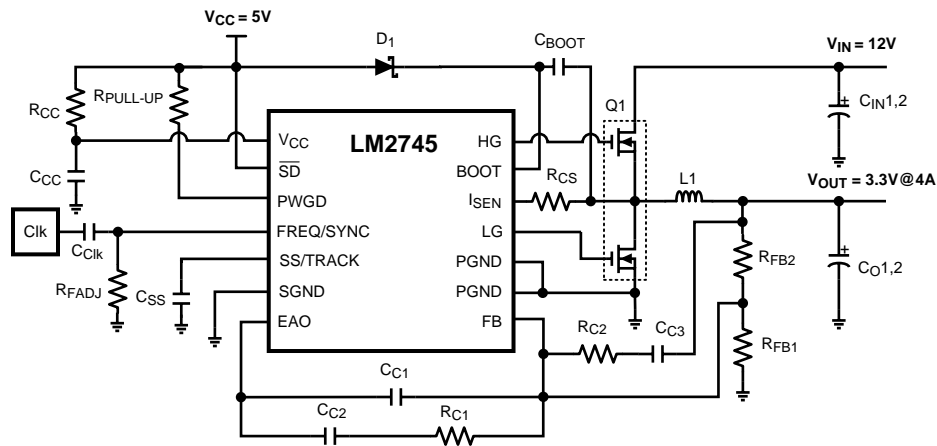

Figure 35. 12V to 3.3V @ 4A, f<sub>sw</sub> = 300kHz

PART	PART NUMBER	TYPE	PACKAGE	DESCRIPTION	VENDOR
U1	LM2745	Synchronous Controller	TSSOP-14		TI
Q1	FDS6898A	Dual N-MOSFET	SO-8	20V, 10 mΩ @ 4.5V, 16 nC	Fairchild
D1	MBR0520LTI	Schottky Diode	SOD-123		
L1	DO3316P-332	Inductor		3.3 μH, 5.4Arms 15 mΩ	Coilcraft
C <sub>IN1</sub>	16SP100M	Aluminum Electrolytic	10mm x 6mm	100 μF, 16V, 2.89Arms	Sanyo
C <sub>O1</sub>	6SP220M	Aluminum Electrolytic	10mm x 6mm	220 μF, 6.3V 3.1Arms	Sanyo
C <sub>CC</sub> , C <sub>BOOT</sub> , C <sub>IN2</sub> , C <sub>O2</sub>	VJ1206Y104KXXA	Capacitor	1206	0.1 μF, 10%	Vishay
C <sub>C3</sub>	VJ0805Y222KXXA	Capacitor	805	2200 pF, 10%	Vishay
C <sub>SS</sub>	VJ0805A123KXAA	Capacitor	805	12 nF, 10%	Vishay
C <sub>C2</sub>	VJ0805Y332KXXA	Capacitor	805	3300 pF 10%	Vishay
C <sub>C1</sub>	VJ0805A820KXAA	Capacitor	805	82 pF, 10%	Vishay
R <sub>FB2</sub>	CRCW08051002F	Resistor	805	10.0 kΩ 1%	Vishay
R <sub>FB1</sub>	CRCW08052211F	Resistor	805	2.21 kΩ 1%	Vishay
R <sub>FADJ</sub>	CRCW08051003F	Resistor	805	100 kΩ 1%	Vishay
R <sub>C2</sub>	CRCW08052611F	Resistor	805	2.61 kΩ 1%	Vishay
R <sub>CS</sub>	CRCW08054121F	Resistor	805	4.12 kΩ 1%	Vishay
R <sub>CC</sub>	CRCW080510R0F	Resistor	805	10.0Ω 1%	Vishay
R <sub>C1</sub>	CRCW08051272F	Resistor	805	12.7kΩ 1%	Vishay
R <sub>PULL-UP</sub>	CRCW08051003J	Resistor	805	100 kΩ 5%	Vishay
C <sub>CLK</sub>	VJ0805A560KXAA	Capacitor	805	56 pF, 10%	Vishay

## REVISION HISTORY

Changes from Revision D (April 2013) to Revision E	Page
• Changed layout of National Data Sheet to TI format .....	<a href="#">29</a>

**PACKAGING INFORMATION**

Orderable Device	Status (1)	Package Type	Package Drawing	Pins	Package Qty	Eco Plan (2)	Lead/Ball Finish (6)	MSL Peak Temp (3)	Op Temp (°C)	Device Marking (4/5)	Samples
LM2745MTC/NOPB	ACTIVE	TSSOP	PW	14	94	Green (RoHS & no Sb/Br)	CU NIPDAU   CU SN	Level-1-260C-UNLIM	-40 to 125	2745 MTC	<a href="#">Samples</a>
LM2745MTCX/NOPB	ACTIVE	TSSOP	PW	14	2500	Green (RoHS & no Sb/Br)	CU NIPDAU   CU SN	Level-1-260C-UNLIM	-40 to 125	2745 MTC	<a href="#">Samples</a>
LM2748MTC/NOPB	ACTIVE	TSSOP	PW	14	94	Green (RoHS & no Sb/Br)	CU SN	Level-1-260C-UNLIM	-40 to 125	2748 MTC	<a href="#">Samples</a>
LM2748MTCX/NOPB	ACTIVE	TSSOP	PW	14	2500	Green (RoHS & no Sb/Br)	CU SN	Level-1-260C-UNLIM	-40 to 125	2748 MTC	<a href="#">Samples</a>

(1) The marketing status values are defined as follows:

**ACTIVE:** Product device recommended for new designs.

**LIFEBUY:** TI has announced that the device will be discontinued, and a lifetime-buy period is in effect.

**NRND:** Not recommended for new designs. Device is in production to support existing customers, but TI does not recommend using this part in a new design.

**PREVIEW:** Device has been announced but is not in production. Samples may or may not be available.

**OBSELETE:** TI has discontinued the production of the device.

(2) Eco Plan - The planned eco-friendly classification: Pb-Free (RoHS), Pb-Free (RoHS Exempt), or Green (RoHS & no Sb/Br) - please check <http://www.ti.com/productcontent> for the latest availability information and additional product content details.

**TBD:** The Pb-Free/Green conversion plan has not been defined.

**Pb-Free (RoHS):** TI's terms "Lead-Free" or "Pb-Free" mean semiconductor products that are compatible with the current RoHS requirements for all 6 substances, including the requirement that lead not exceed 0.1% by weight in homogeneous materials. Where designed to be soldered at high temperatures, TI Pb-Free products are suitable for use in specified lead-free processes.

**Pb-Free (RoHS Exempt):** This component has a RoHS exemption for either 1) lead-based flip-chip solder bumps used between the die and package, or 2) lead-based die adhesive used between the die and leadframe. The component is otherwise considered Pb-Free (RoHS compatible) as defined above.

**Green (RoHS & no Sb/Br):** TI defines "Green" to mean Pb-Free (RoHS compatible), and free of Bromine (Br) and Antimony (Sb) based flame retardants (Br or Sb do not exceed 0.1% by weight in homogeneous material)

(3) MSL, Peak Temp. - The Moisture Sensitivity Level rating according to the JEDEC industry standard classifications, and peak solder temperature.

(4) There may be additional marking, which relates to the logo, the lot trace code information, or the environmental category on the device.

(5) Multiple Device Markings will be inside parentheses. Only one Device Marking contained in parentheses and separated by a "~" will appear on a device. If a line is indented then it is a continuation of the previous line and the two combined represent the entire Device Marking for that device.

(6) Lead/Ball Finish - Orderable Devices may have multiple material finish options. Finish options are separated by a vertical ruled line. Lead/Ball Finish values may wrap to two lines if the finish value exceeds the maximum column width.

**Important Information and Disclaimer:** The information provided on this page represents TI's knowledge and belief as of the date that it is provided. TI bases its knowledge and belief on information provided by third parties, and makes no representation or warranty as to the accuracy of such information. Efforts are underway to better integrate information from third parties. TI has taken and continues to take reasonable steps to provide representative and accurate information but may not have conducted destructive testing or chemical analysis on incoming materials and chemicals. TI and TI suppliers consider certain information to be proprietary, and thus CAS numbers and other limited information may not be available for release.

In no event shall TI's liability arising out of such information exceed the total purchase price of the TI part(s) at issue in this document sold by TI to Customer on an annual basis.

**TAPE AND REEL INFORMATION**

**QUADRANT ASSIGNMENTS FOR PIN 1 ORIENTATION IN TAPE**

\*All dimensions are nominal

Device	Package Type	Package Drawing	Pins	SPQ	Reel Diameter (mm)	Reel Width W1 (mm)	A0 (mm)	B0 (mm)	K0 (mm)	P1 (mm)	W (mm)	Pin1 Quadrant
LM2745MTCX/NOPB	TSSOP	PW	14	2500	330.0	12.4	6.95	5.6	1.6	8.0	12.0	Q1
LM2748MTCX/NOPB	TSSOP	PW	14	2500	330.0	12.4	6.95	5.6	1.6	8.0	12.0	Q1

**TAPE AND REEL BOX DIMENSIONS**

\*All dimensions are nominal

Device	Package Type	Package Drawing	Pins	SPQ	Length (mm)	Width (mm)	Height (mm)
LM2745MTCX/NOPB	TSSOP	PW	14	2500	367.0	367.0	35.0
LM2748MTCX/NOPB	TSSOP	PW	14	2500	367.0	367.0	35.0

PW (R-PDSO-G14)

PLASTIC SMALL OUTLINE



4040064-3/G 02/11

- NOTES:
- A. All linear dimensions are in millimeters. Dimensioning and tolerancing per ASME Y14.5M-1994.
  - B. This drawing is subject to change without notice.
  - C. Body length does not include mold flash, protrusions, or gate burrs. Mold flash, protrusions, or gate burrs shall not exceed 0,15 each side.
  - D. Body width does not include interlead flash. Interlead flash shall not exceed 0,25 each side.
  - E. Falls within JEDEC MO-153

PW (R-PDSO-G14)

PLASTIC SMALL OUTLINE



4211284-2/G 08/15

- NOTES:
- All linear dimensions are in millimeters.
  - This drawing is subject to change without notice.
  - Publication IPC-7351 is recommended for alternate designs.
  - Laser cutting apertures with trapezoidal walls and also rounding corners will offer better paste release. Customers should contact their board assembly site for stencil design recommendations. Refer to IPC-7525 for other stencil recommendations.
  - Customers should contact their board fabrication site for solder mask tolerances between and around signal pads.

## IMPORTANT NOTICE

Texas Instruments Incorporated and its subsidiaries (TI) reserve the right to make corrections, enhancements, improvements and other changes to its semiconductor products and services per JESD46, latest issue, and to discontinue any product or service per JESD48, latest issue. Buyers should obtain the latest relevant information before placing orders and should verify that such information is current and complete. All semiconductor products (also referred to herein as "components") are sold subject to TI's terms and conditions of sale supplied at the time of order acknowledgment.

TI warrants performance of its components to the specifications applicable at the time of sale, in accordance with the warranty in TI's terms and conditions of sale of semiconductor products. Testing and other quality control techniques are used to the extent TI deems necessary to support this warranty. Except where mandated by applicable law, testing of all parameters of each component is not necessarily performed.

TI assumes no liability for applications assistance or the design of Buyers' products. Buyers are responsible for their products and applications using TI components. To minimize the risks associated with Buyers' products and applications, Buyers should provide adequate design and operating safeguards.

TI does not warrant or represent that any license, either express or implied, is granted under any patent right, copyright, mask work right, or other intellectual property right relating to any combination, machine, or process in which TI components or services are used. Information published by TI regarding third-party products or services does not constitute a license to use such products or services or a warranty or endorsement thereof. Use of such information may require a license from a third party under the patents or other intellectual property of the third party, or a license from TI under the patents or other intellectual property of TI.

Reproduction of significant portions of TI information in TI data books or data sheets is permissible only if reproduction is without alteration and is accompanied by all associated warranties, conditions, limitations, and notices. TI is not responsible or liable for such altered documentation. Information of third parties may be subject to additional restrictions.

Resale of TI components or services with statements different from or beyond the parameters stated by TI for that component or service voids all express and any implied warranties for the associated TI component or service and is an unfair and deceptive business practice. TI is not responsible or liable for any such statements.

Buyer acknowledges and agrees that it is solely responsible for compliance with all legal, regulatory and safety-related requirements concerning its products, and any use of TI components in its applications, notwithstanding any applications-related information or support that may be provided by TI. Buyer represents and agrees that it has all the necessary expertise to create and implement safeguards which anticipate dangerous consequences of failures, monitor failures and their consequences, lessen the likelihood of failures that might cause harm and take appropriate remedial actions. Buyer will fully indemnify TI and its representatives against any damages arising out of the use of any TI components in safety-critical applications.

In some cases, TI components may be promoted specifically to facilitate safety-related applications. With such components, TI's goal is to help enable customers to design and create their own end-product solutions that meet applicable functional safety standards and requirements. Nonetheless, such components are subject to these terms.

No TI components are authorized for use in FDA Class III (or similar life-critical medical equipment) unless authorized officers of the parties have executed a special agreement specifically governing such use.

Only those TI components which TI has specifically designated as military grade or "enhanced plastic" are designed and intended for use in military/aerospace applications or environments. Buyer acknowledges and agrees that any military or aerospace use of TI components which have **not** been so designated is solely at the Buyer's risk, and that Buyer is solely responsible for compliance with all legal and regulatory requirements in connection with such use.

TI has specifically designated certain components as meeting ISO/TS16949 requirements, mainly for automotive use. In any case of use of non-designated products, TI will not be responsible for any failure to meet ISO/TS16949.

### Products

Audio	<a href="http://www.ti.com/audio">www.ti.com/audio</a>
Amplifiers	<a href="http://amplifier.ti.com">amplifier.ti.com</a>
Data Converters	<a href="http://dataconverter.ti.com">dataconverter.ti.com</a>
DLP® Products	<a href="http://www.dlp.com">www.dlp.com</a>
DSP	<a href="http://dsp.ti.com">dsp.ti.com</a>
Clocks and Timers	<a href="http://www.ti.com/clocks">www.ti.com/clocks</a>
Interface	<a href="http://interface.ti.com">interface.ti.com</a>
Logic	<a href="http://logic.ti.com">logic.ti.com</a>
Power Mgmt	<a href="http://power.ti.com">power.ti.com</a>
Microcontrollers	<a href="http://microcontroller.ti.com">microcontroller.ti.com</a>
RFID	<a href="http://www.ti-rfid.com">www.ti-rfid.com</a>
OMAP Applications Processors	<a href="http://www.ti.com/omap">www.ti.com/omap</a>
Wireless Connectivity	<a href="http://www.ti.com/wirelessconnectivity">www.ti.com/wirelessconnectivity</a>

### Applications

Automotive and Transportation	<a href="http://www.ti.com/automotive">www.ti.com/automotive</a>
Communications and Telecom	<a href="http://www.ti.com/communications">www.ti.com/communications</a>
Computers and Peripherals	<a href="http://www.ti.com/computers">www.ti.com/computers</a>
Consumer Electronics	<a href="http://www.ti.com/consumer-apps">www.ti.com/consumer-apps</a>
Energy and Lighting	<a href="http://www.ti.com/energy">www.ti.com/energy</a>
Industrial	<a href="http://www.ti.com/industrial">www.ti.com/industrial</a>
Medical	<a href="http://www.ti.com/medical">www.ti.com/medical</a>
Security	<a href="http://www.ti.com/security">www.ti.com/security</a>
Space, Avionics and Defense	<a href="http://www.ti.com/space-avionics-defense">www.ti.com/space-avionics-defense</a>
Video and Imaging	<a href="http://www.ti.com/video">www.ti.com/video</a>

### TI E2E Community

[e2e.ti.com](http://e2e.ti.com)

## Looking for pricing, stock, or lifecycle information?

Click below to explore more details on WIN SOURCE:

 [View LM2748MTC/NOPB on WIN SOURCE](#)

 [Texas Instruments](#) Information

## Optimize Your Supply Chain with WIN SOURCE Solutions

-  Global Sourcing Solution
-  Obsolete Management
-  Cost Control Management
-  Shortage Management
-  Alternative Solution
-  Excess Inventory Management