



**THE DATASHEET OF  
SG1532J**



# Precision General - Purpose Regulator

## Description

This monolithic integrated circuit is a versatile, general-purpose voltage regulator designed as a substantially improved replacement for the popular SG723 device. The SG1532 series regulators retain all the versatility of the SG723 but have the added benefits of operation. The SG1532 series have input voltages as low as 4.5 V and as high as 50 V, a low noise, low voltage reference temperature compensated, low threshold current limiting and protective circuits which include thermal shutdown and independent current limiting of both the reference and output voltages. A separate remote shutdown terminal is included. In the dual-in-line package an open collector output is available for low input-output differential applications.

These devices are available in a hermetic 14-pin CERDIP. The SG1532 is rated for operation over the ambient temperature range of -55°C to 125°C.

## Features

- Input Voltage Range of 4.5 V to 50 V
- 2.5 V Low Noise Reference
- Independent Shutdown Terminal
- Improved Line and Load Regulation
- 80 mV Current Limit Sense Voltage
- Fully Protected Including Thermal Shutdown
- Useful Output Current to 150 mA

## High Reliability Features

- Available to MIL-STD-883, ¶ 1.2.1
- Available to DSCC
  - Standard Microcircuit Drawing (SMD)
- MSC-AMS level “S” Processing Available

## Block Diagram

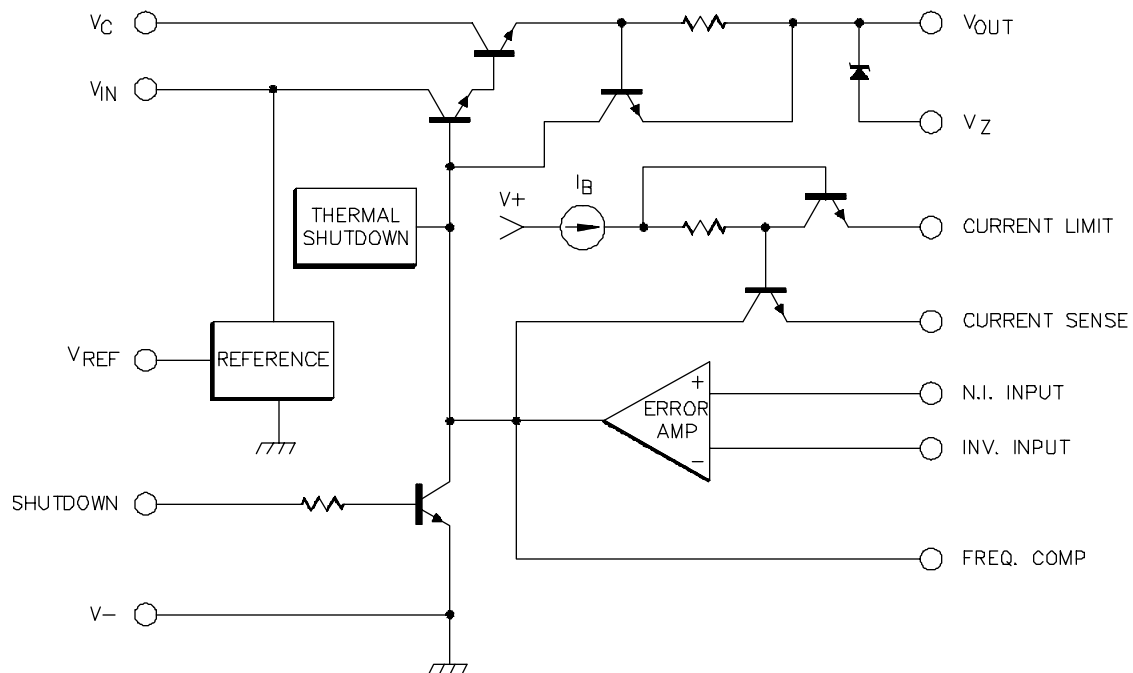

Figure 1 · Block Diagram

## Absolute Maximum Ratings (Note 1)

Pulse (50 ms) Input Voltage from $V_{IN}$ to $V_-$ .....	50 V	Current from $V_{REF}$ .....	25 mA
Continuous Input Voltage from $V_{IN}$ to $V_-$ .....	40 V	Operating Junction Temperature	
Input to Output Voltage Differential .....	40 V	Storage Temperature Range .....	-65°C to 150°C
Maximum Output Current .....	250 mA	Lead Temperature (Soldering, 10s) .....	300°C
Current from $V_Z$ .....	100 mA		

Note 1. Exceeding these ratings could cause damage to the device.

## Thermal Data

J Package:

Thermal Resistance-Junction to Case, $\theta_{JC}$ .....	30°C/W
Thermal Resistance-Junction to Ambient, $\theta_{JA}$ .....	80°C/W

Note A. Junction Temperature Calculation:  $T_J = T_A + (P_D \times \theta_{JA})$ .

Note B. The above numbers for  $\theta_{JC}$  are maximums for the limiting thermal resistance of the package in a standard mounting configuration. The  $\theta_{JA}$  numbers are meant to be guidelines for the thermal performance of the device/pc-board system. All of the above assume no ambient airflow.

## Recommended Operating Conditions (Note 2)

Input Voltage Range		Reference Current .....	5 mA
SG1532 .....	5 V to 45 V	Zener Current .....	20 mA
Output Current Range .....	1 mA to 100 mA	Operating Ambient Temperature Range	
		SG1532 .....	-55°C to 125°C

Note 2. Range over which the device is functional.

## Electrical Characteristics

(Unless otherwise specified, these specifications apply over the operating ambient temperature for SG1532 with  $-55^\circ\text{C} \leq T_A \leq 125^\circ\text{C}$ ,  $V_{IN} = 10\text{ V}$ ,  $V_{OUT} = 5\text{ V}$ , and  $I_{OUT} = 1\text{ mA}$ . Low duty cycle pulse testing techniques are used which maintains junction and case temperatures equal to the ambient temperature.)

Parameter	Test Conditions	SG1532			Units
		Min.	Typ.	Max.	
Input Voltage Range	$T_A = 25^\circ\text{C}$	4.5		50	V
		4.7		50	V
Output Voltage Range		2.0		38	V
Max Output Current	$R_{SC} = 0, V_{OUT} = 0, T_A = 25^\circ\text{C}$		175	250	mA
Min ( $V_{IN} - V_{OUT}$ )	$I_{OUT} = 100\text{ mA}, T_A = 25^\circ\text{C}$		1.7	2.0	V
Reference Voltage	$T_A = 25^\circ\text{C}$	2.40	2.50	2.60	V
		2.35		2.65	V
Temperature Stability (Note 4)			0.005	0.015	%/°C
Ref Short Circuit Current	$V_{REF} = 0, T_A = 25^\circ\text{C}$		15	25	mA
Line Regulation (Note 3)	$8\text{ V} \leq V_{IN} \leq 40\text{ V}$		0.005	0.01	%/V
	$8\text{ V} \leq V_{IN} \leq 20\text{ V}, I_{OUT} = 25\text{ mA}$		0.01	0.02	%/V
Load Regulation (Note 3)	$1\text{ mA} \leq I_{OUT} \leq 25\text{ mA}$		0.002	0.004	%/mA
	$1\text{ mA} \leq I_{OUT} \leq 100\text{ mA}$		0.002	0.005	%/mA
Current Limit Sense Voltage	$R_{SC} = 100\ \Omega, V_{OUT} = 0\text{ V}$	0.06	0.08	0.10	V
Shutdown Voltage Threshold		0.40	0.70	1.0	V
Shutdown Source Current	$V_{OUT} = \text{high}$	100	200	300	$\mu\text{A}$
Zener Voltage	$I_{OUT} = 10\text{ mA}$	6.0	6.4	7.2	V
Standby Current	$V_{IN} = 40\text{ V}$		2.5	3.5	mA
Error Amplifier Offset Voltage			2.0	10	mV
Error Amplifier Input Bias Current			4.0	15	$\mu\text{A}$

## Electrical Characteristics (Continued)

Parameter	Test Conditions	SG1532			Units
		Min.	Typ.	Max.	
Open Loop Gain	$T_A = 25^\circ\text{C}$	66	68		dB
Ripple Rejection	$f = 120\text{ Hz}, T_A = 25^\circ\text{C}$		66		dB
Output Noise (Note 4)	$10\text{ Hz} \leq f \leq 100\text{ kHz}, T_A = 25^\circ\text{C}$		50		$\mu\text{V}_{\text{RMS}}$
Long Term Stability (Note 4)	$V_{\text{IN}} = 30\text{ V}, T_A = 125^\circ\text{C}$		0.3	1.0	%/khr
Thermal Shutdown (Note 4)			175		$^\circ\text{C}$

Note 3. Applies for constant junction temperature. Temperature drift effects must be taken into account separately when the unit is operating under conditions of high dissipation.

Note 4. These parameters, although guaranteed, are not tested in production.

## Characteristics Curves

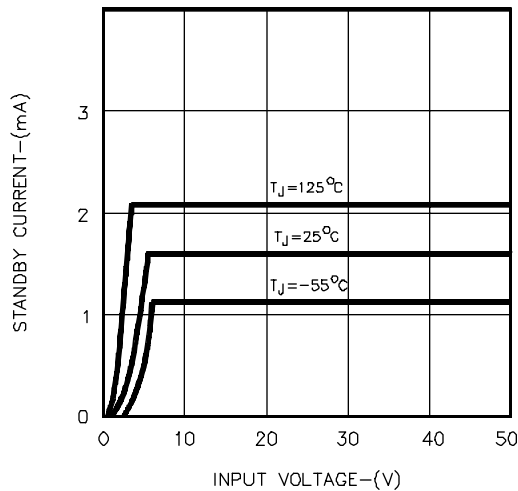

Figure 2. Standby Current

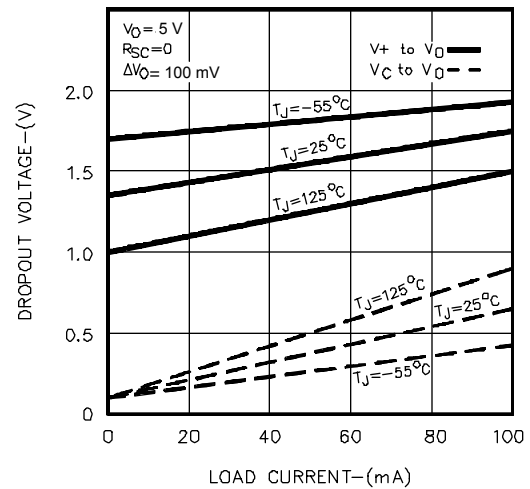

Figure 3. Minimum Input-Output Voltage

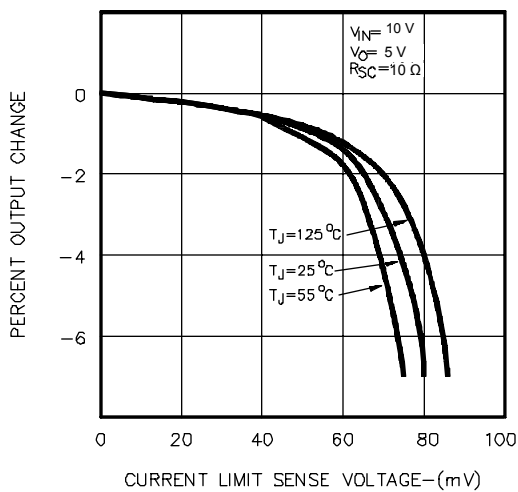

Figure 4. Current Limiting

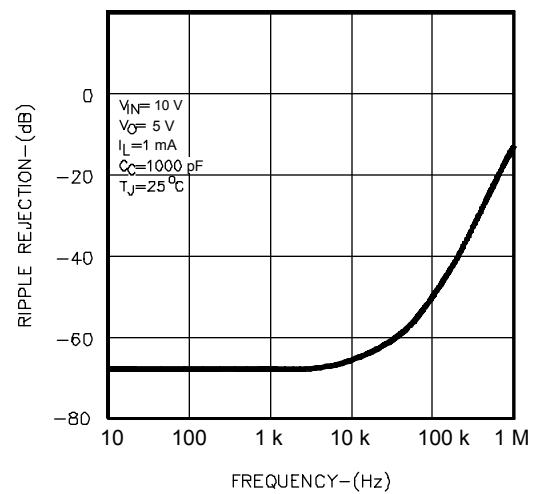

Figure 5. Ripple Rejection

## Characteristics Curves (Continued)

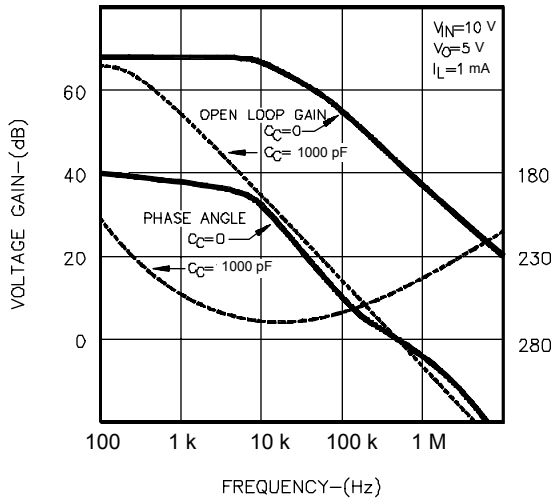

Figure 6. Frequency Response

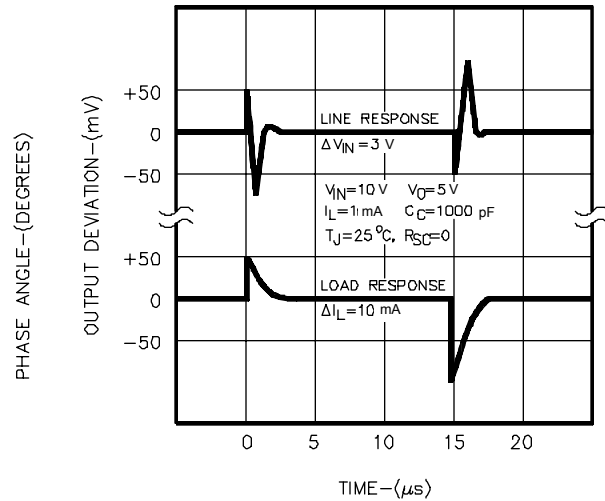

Figure 7. Transient Response

## Application Information

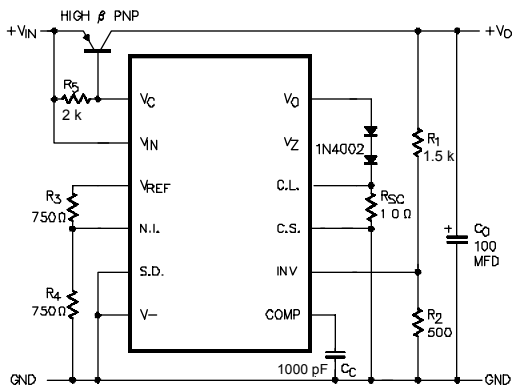

Figure 8. 90% Efficient Linear Regulator

Output Voltage = 5 V  
 Min  $(V_{IN} - V_{OUT})$  at 2 A = 0.4 V  
 Load Reg 0-2 A = 20 mV  
 Max Output Current = 3 A  
 Line Reg 6-30 V = 10 mV

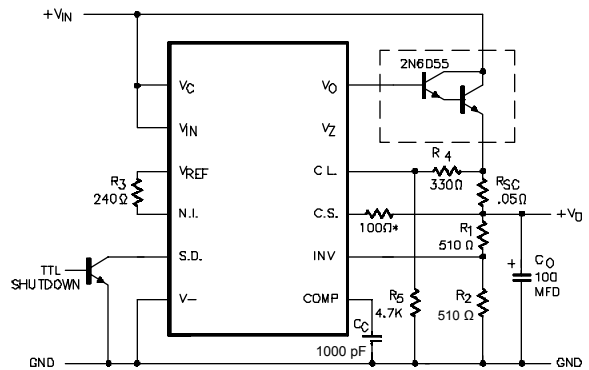

Figure 9. High Current Regulator with Foldback Current Limiting and Remote Shutdown

Output Voltage = 5 V  
 Max Output Current = 8 A  
 Min  $V_{IN}$  at No Load = 6.9 V  
 Min  $V_{IN}$  at 5 A = 8.2 V  
 Line Reg 10-30 V = 3 mV  
 Load Reg 0-5 A = 17 mV  
 Short Circuit Current = 1.8 A

### Notes:

- For output voltages above 8 V and load currents which allow PNP base current to be limited to 25 mA, the internal zener may be used, eliminating the need for the two external diodes and the divider on  $V_{REF}$ .
- $R_{SC}$  can be eliminated if the 200 mA current limit on  $V_{OUT}$  is adequate. Overall current limiting is dependent upon PNP Beta. For greater accuracy, load current may be sensed in the ground line.

### Note:

- \* 100  $\Omega$  surge limiting resistor should be used for output voltages above 8 V.

## Application Information (Continued)

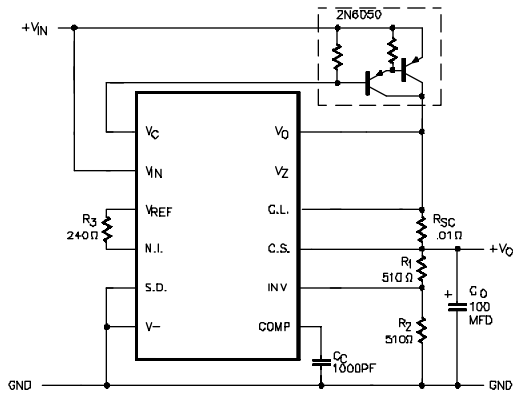

**Figure 10.** High Efficiency Low Voltage Regulator

Output Voltage = 5 V  
 Max Output Current = 9 A  
 Min  $V_{IN}$  at 5 A = 7.0 V

Line Reg 7-20 V = 10 mV  
 Load Reg 0-5 A = 25 mV  
 Constant Current Limiting

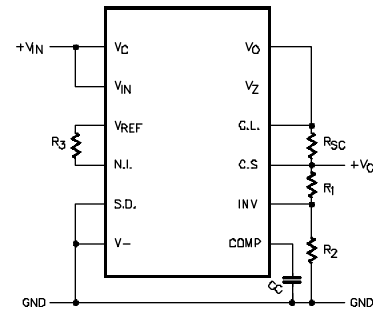

**Figure 11.** Basic Low Current Regulator

$$V_{OUT} = V_{REF} \left( 1 + \frac{R_1}{R_2} \right)$$

$$I_{SC} = \frac{\text{Sense Voltage}}{R_{SC}} = \frac{R_1 R_2}{R_1 + R_2}$$

$$C_C = 1000 \text{ pF}$$

$$I_{OUT} \leq 100 \text{ mA}$$

## Connection Diagrams and Ordering Information (See Notes Below)

Package	Part Number	Ambient Temperature Range	Connection Diagram
14-PIN CERAMIC DIP J - PACKAGE	SG1532J-883B SG1532J-DESC SG1532J	-55°C to 125°C -55°C to 125°C -55°C to 125°C	

- Note 1. Contact factory for JAN product availability.  
 Note 2. All packages are viewed from the top.

## Package Outline Dimensions

Controlling dimensions are in inches, metric equivalents are shown for general information.

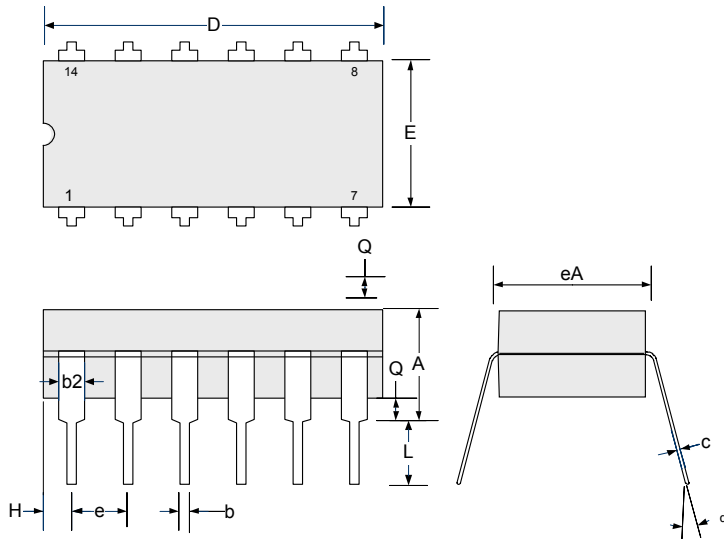

DIM	MILLIMETERS		INCHES	
	MIN	MAX	MIN	MAX
A	-	5.08	-	0.200
b	0.38	0.51	0.015	0.020
b2	1.04	1.65	0.045	0.065
c	0.20	0.38	0.008	0.015
D	19.30	19.94	0.760	0.785
E	5.59	7.11	0.220	0.280
e	2.54 BSC		0.100 BSC	
eA	7.37	7.87	0.290	0.310
H	0.63	1.78	0.025	0.070
L	3.18	5.08	0.125	0.200
$\alpha$	-	15°	-	15°
Q	0.51	1.02	0.020	0.040

**Note:**

Dimensions do not include protrusions; these shall not exceed 0.155 mm (.006") on any side. Lead dimension shall not include solder coverage.

**Figure 12 - J 14-Pin Ceramic Dip Package Dimensions**



**Microsemi Corporate Headquarters**

One Enterprise, Aliso Viejo,  
CA 92656 USA

**Within the USA:** +1 (800) 713-4113

**Outside the USA:** +1 (949) 380-6100

**Sales:** +1 (949) 380-6136

**Fax:** +1 (949) 215-4996

**E-mail:** [sales.support@microsemi.com](mailto:sales.support@microsemi.com)

© 2015 Microsemi Corporation. All rights reserved. Microsemi and the Microsemi logo are trademarks of Microsemi Corporation. All other trademarks and service marks are the property of their respective owners.

Microsemi Corporation (MSCC) offers a comprehensive portfolio of semiconductor and system solutions for communications, defense & security, aerospace and industrial markets. Products include high-performance and radiation-hardened analog mixed-signal integrated circuits, FPGAs, SoCs and ASICs; power management products; timing and synchronization devices and precise time solutions, setting the world's standard for time; voice processing devices; RF solutions; discrete components; security technologies and scalable anti-tamper products; Ethernet solutions; Power-over-Ethernet ICs and midspans; as well as custom design capabilities and services. Microsemi is headquartered in Aliso Viejo, Calif., and has approximately 3,600 employees globally. Learn more at [www.microsemi.com](http://www.microsemi.com).

Microsemi makes no warranty, representation, or guarantee regarding the information contained herein or the suitability of its products and services for any particular purpose, nor does Microsemi assume any liability whatsoever arising out of the application or use of any product or circuit. The products sold hereunder and any other products sold by Microsemi have been subject to limited testing and should not be used in conjunction with mission-critical equipment or applications. Any performance specifications are believed to be reliable but are not verified, and Buyer must conduct and complete all performance and other testing of the products, alone and together with, or installed in, any end-products. Buyer shall not rely on any data and performance specifications or parameters provided by Microsemi. It is the Buyer's responsibility to independently determine suitability of any products and to test and verify the same. The information provided by Microsemi hereunder is provided "as is, where is" and with all faults, and the entire risk associated with such information is entirely with the Buyer. Microsemi does not grant, explicitly or implicitly, to any party any patent rights, licenses, or any other IP rights, whether with regard to such information itself or anything described by such information. Information provided in this document is proprietary to Microsemi, and Microsemi reserves the right to make any changes to the information in this document or to any products and services at any time without notice.

## Looking for pricing, stock, or lifecycle information?

Click below to explore more details on WIN SOURCE:

- ⊖ [View SG1532J on WIN SOURCE](#)
- ⊖ [Microchip Technology](#) Information

## Optimize Your Supply Chain with WIN SOURCE Solutions

- ✓ Global Sourcing Solution
- ✓ Obsolete Management
- ✓ Cost Control Management
- ✓ Shortage Management
- ✓ Alternative Solution
- ✓ Excess Inventory Management