



**THE DATASHEET OF
SN65LBC172N**



SN65LBC172, SN75LBC172 Quadruple Low-Power Differential Line Driver

1 Features

- Exceeds or meets EIA standard RS-485
- Designed for high-speed multipoint transmission on long bus lines in noisy environments
- Supports data rates up to and exceeding ten million transfers per second
- Provides a common-mode output voltage range of -7V to 12V
- Offers positive-and negative-current limiting
- Consumes low power to 1.5mA max (output disabled)
- Functions interchangeably with the SN75172

2 Applications

- Motor drives
- Factory automation and control

3 Description

The SN65LBC172 and SN75LBC172 are monolithic quadruple differential line drivers with three-state outputs. Both devices are designed to meet the requirements of EIA Standard RS-485. These devices are optimized for balanced multipoint bus transmission at data rates up to and exceeding 10 million bits per second. Each driver features wide positive and negative common- mode output voltage

ranges, current limiting, and thermal-shutdown circuitry which provides a party-line application in noisy environments. Both devices are designed using LinBiCMOS™, facilitating ultra-low power consumption and inherent robustness.

Both the SN65LBC172 and SN75LBC172 provide positive- and negative-current limiting and thermal shutdown for protection from line fault conditions on the transmission bus line. These devices offer optimum performance when used with the SN75LBC173 or SN75LBC175 quadruple line receivers. The SN65LBC172 and SN75LBC172 are available in the 16-pin DIP package (N) and the 20-pin wide-body small-outline inline-circuit (SOIC) package (DW).

The SN75LBC172 is characterized for operation over the commercial temperature range of 0°C to 70°C. The SN65LBC172 is characterized over the industrial temperature range of -40°C to 85°C.

Package Information

PART NUMBER	PACKAGE ⁽¹⁾	PACKAGE SIZE ⁽²⁾
SN65LBC172	DW (SOIC, 20)	10.3mm × 10.3mm
SN75LBC172	N (PDIP 16)	19.3mm × 9.4mm

(1) For more information, see [Section 10](#).

(2) The package size (length × width) is a nominal value and includes pins, where applicable.

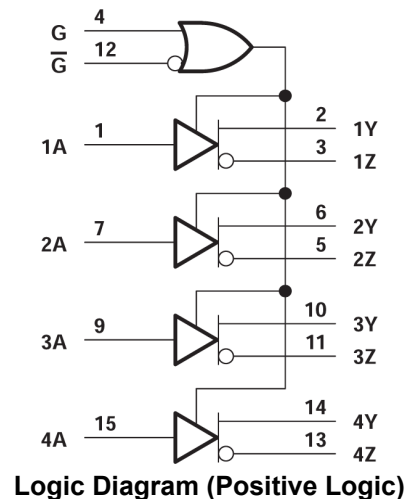
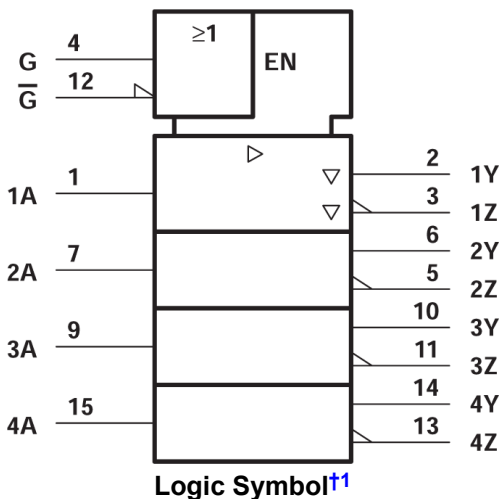

† This symbol is in accordance with ANSI/IEEE Std 91-1984 and IEC Publication 617-12.

¹ Pin numbers shown are for the N package.



Table of Contents

1 Features	1	7 Detailed Description	11
2 Applications	1	7.1 Thermal Characteristics of Ic Packages.....	11
3 Description	1	7.2 Device Functional Modes.....	12
4 Pin Configuration and Functions	3	8 Device and Documentation Support	13
5 Specifications	5	8.1 Receiving Notification of Documentation Updates....	13
5.1 Absolute Maximum Ratings.....	5	8.2 Support Resources.....	13
5.2 Recommended Operating Conditions.....	5	8.3 Trademarks.....	13
5.3 Dissipation Rating Table.....	5	8.4 Electrostatic Discharge Caution.....	13
5.4 Thermal Information.....	6	8.5 Glossary.....	13
5.5 Electrical Characteristics.....	6	9 Revision History	13
5.6 Switching Characteristics.....	7	10 Mechanical, Packaging, and Orderable	
5.7 Typical Characteristics.....	8	Information	13
6 Parameter Measurement Information	9		

4 Pin Configuration and Functions

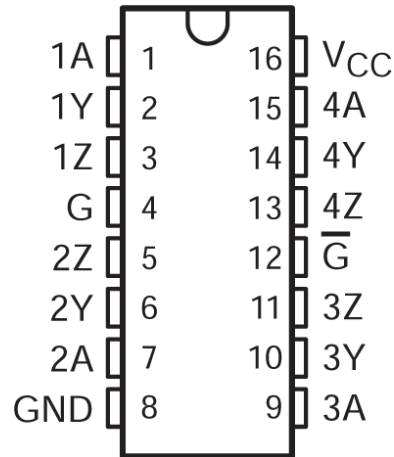
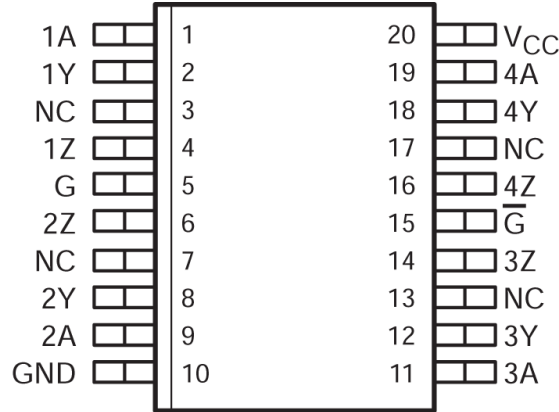

Figure 4-1. N Package (Top View)

Table 4-1. Pin Functions

PIN		TYPE ⁽¹⁾	DESCRIPTION
NAME	NO.		
1A	1	I	Driver 1 input
1Y	2	O	Driver 1 output
1Z	3	O	Driver 1 inverted output
G	4	I	Active high enable all drivers
2Z	5	O	Driver 2 inverted output
2Y	6	O	Driver 2 output
2A	7	I	Driver 2 input
GND	8	G	Ground pin
3A	9	I	Driver 3 input
3Y	10	O	Driver 3 output
3Z	11	O	Driver 3 inverted output
\bar{G}	12	I	Active low enable all drivers
4Z	13	O	Driver 4 inverted output
4Y	14	O	Driver 4 output
4A	15	O	Driver 4 input
V _{CC}	16	P	Power pin

(1) I = Input, O = Output, I/O = Input or Output, G = Ground, P = Power.



NC – No internal connection

Figure 4-2. DW Package (Top View)

Table 4-2. Pin Functions

PIN		TYPE ⁽¹⁾	DESCRIPTION
NAME	NO.		
1A	1	I	Driver 1 input
1Y	2	O	Driver 1 output
NC	3	-	No Internal Connection
1Z	4	O	Driver 1 inverted output
G	5	I	Active high enable all drivers
2Z	6	O	Driver 2 inverted output
NC	7	-	No Internal Connection
2Y	8	O	Driver 2 output
2A	9	I	Driver 2 input
GND	10	G	Ground pin
3A	11	I	Driver 3 input
3Y	12	O	Driver 3 output
NC	13	-	No Internal Connection
3Z	14	O	Driver 3 inverted output
\bar{G}	15	I	Active low enable all drivers
4Z	16	O	Driver 4 inverted output
NC	17	-	No Internal Connection
4Y	18	O	Driver 4 output
4A	19	I	Driver 4 input
V _{CC}	20	P	Power pin

(1) I = Input, O = Output, I/O = Input or Output, G = Ground, P = Power.

5 Specifications

5.1 Absolute Maximum Ratings

over operating free-air temperature range (unless otherwise noted)⁽¹⁾

		MIN	MAX	UNIT
V _{CC}	Supply voltage range, (see ⁽³⁾)	-0.3	7	V
V _O	Output voltage range	-10	15	V
V _I	Voltage range at A, \bar{G} , G	-0.3	V _{CC} + 0.5	V
P _D	Continuous power dissipation	Internally limited ⁽²⁾		
T _{stg}	Storage temperature range	-65	150	°C
T _{LEAD}	Lead temperature 1,6mm (1/16 inch) from case for 10 seconds		260	°C

- (1) Stresses beyond those listed under “absolute maximum ratings” may cause permanent damage to the device. These are stress ratings only, and functional operation of the device at these or any other conditions beyond those indicated under “recommended operating conditions” is not implied. Exposure to absolute-maximum-rated conditions for extended periods may affect device reliability.
- (2) The maximum operating junction temperature is internally limited. Use the dissipation rating table to operate below this temperature.
- (3) All voltage values are with respect to GND.

5.2 Recommended Operating Conditions

		MIN	NOM	MAX	UNIT
Supply voltage, V _{CC}		4.75	5	5.25	V
High-level input voltage, V _{IH}		2			V
Low-level input voltage, V _{IL}				0.8	V
Voltage at any bus terminal (separately or common mode), V _O	Y or Z	-7		12	V
High-level output current, I _{OH}	Y or Z			-60	mA
Low-level output current, I _{OL}	Y or Z			60	mA
Continuous total power dissipation		See Dissipation Rating Table			
Junction temperature, T _J				140	°C
Operating free-air temperature, T _A	SN65LBC172	-40		85	°C
	SN75LBC172	0		70	

5.3 Dissipation Rating Table

PACKAGE	THERMAL MODEL	T _A < 25°C POWER RATING	DERATING FACTOR ABOVE T _A = 25°C	T _A = 70°C POWER RATING	T _A = 85°C POWER RATING
DW	Low K ⁽¹⁾	1094mW	10.4mW/°C	625mW	469mW
	High K ⁽²⁾	1669mW	15.9mW/°C	954mW	715mW
N		1150mW	9.2mW/°C	736mW	598mW

- (1) In accordance with the low effective thermal conductivity metric definitions of EIA/JESD 51-3.
- (2) In accordance with the high effective thermal conductivity metric definitions of EIA/JESD 51-7.

5.4 Thermal Information

THERMAL METRIC ⁽¹⁾		N (PDIP)	DW (SOIC)	UNIT
		16 PINS	20 PINS	
$R_{\theta JA}$	Junction-to-ambient thermal resistance	60.6	66.8	°C/W
$R_{\theta JC(top)}$	Junction-to-case (top) thermal resistance	48.1	34.4	°C/W
$R_{\theta JB}$	Junction-to-board thermal resistance	40.6	39.7	°C/W
Ψ_{JT}	Junction-to-top characterization parameter	27.5	8.9	°C/W
Ψ_{JB}	Junction-to-board characterization parameter	40.3	39	°C/W
$R_{\theta JC(bot)}$	Junction-to-case (bottom) thermal resistance	n/a	n/a	°C/W

- (1) For more information about traditional and new thermal metrics, see the [Semiconductor and IC Package Thermal Metrics](#) application report.

5.5 Electrical Characteristics

over recommended ranges of supply voltage and operating free-air temperature (unless otherwise noted)

PARAMETER		TEST CONDITIONS		MIN	TYP ⁽¹⁾	MAX	UNIT
V_{IK}	Input clamp voltage	$I_I = -18\text{mA}$				-1.5	V
$ V_{OD} $	Differential output voltage ⁽²⁾	$R_L = 54\Omega$ See Figure 6-1	SN65LBC172	1.1	1.8	5	V
			SN75LBC172	1.5	1.8	5	
		$R_L = 60\Omega$, See Figure 6-2	SN65LBC172	1.1	1.7	5	V
			SN75LBC172	1.5	1.7	5	
$\Delta V_{OD} $	Change in magnitude of common-mode output voltage ⁽³⁾	$R_L = 54\Omega$, See Figure 6-1				±0.2	V
V_{OC}	Common-mode output voltage			-1		3	V
$\Delta V_{OC} $	Change in magnitude of common-mode output voltage ⁽³⁾						±0.2
I_O	Output current with power off	$V_{CC} = 0$,	$V_O = -7\text{V to }12\text{V}$			± 100	μA
I_{OZ}	High-impedance-state output current	$V_O = -7\text{V to }12\text{V}$				± 100	μA
I_{IH}	High-level input current	$V_I = 2.4\text{V}$				-100	μA
I_{IL}	Low-level input current	$V_I = 0.4\text{V}$				-100	μA
I_{OS}	Short-circuit output current	$V_O = -7\text{V to }12\text{V}$				±250	mA
I_{CC}	Supply current (all drivers)	No load	Outputs enabled			7	mA
			Outputs disabled			1.5	

- (1) All typical values are at $V_{CC} = 5\text{V}$ and $T_A = 25^\circ\text{C}$.
(2) The minimum V_{OD} specification does not fully comply with EIA-485 at operating temperatures below 0°C . The lower output signal should be used to determine the maximum signal-transmission distance.
(3) $\Delta|V_{OD}|$ and $\Delta|V_{OC}|$ are the changes in magnitude of V_{OD} and V_{OC} , respectively, that occur when the input changes from a high level to a low level.

5.6 Switching Characteristics

$V_{CC} = 5\text{ V}$, $T_A = 25^\circ\text{C}$

PARAMETER		TEST CONDITIONS		MIN	TYP	MAX	UNIT
$t_{d(OD)}$	Differential output delay time	$R_L = 54\Omega$,	See Figure 6-3	2	11	20	ns
$t_{t(OD)}$	Differential output transition time			9	15	25	
t_{PZH}	Output enable time to high level	$R_L = 110\Omega$,	See Figure 6-4		20	30	ns
t_{PZL}	Output enable time to low level	$R_L = 110\Omega$,	See Figure 6-5		21	30	ns
t_{PHZ}	Output disable time from high level	$R_L = 110\Omega$,	See Figure 6-4		48	70	ns
t_{PLZ}	Output disable time from low level	$R_L = 110\Omega$,	See Figure 6-5		21	30	ns

5.7 Typical Characteristics

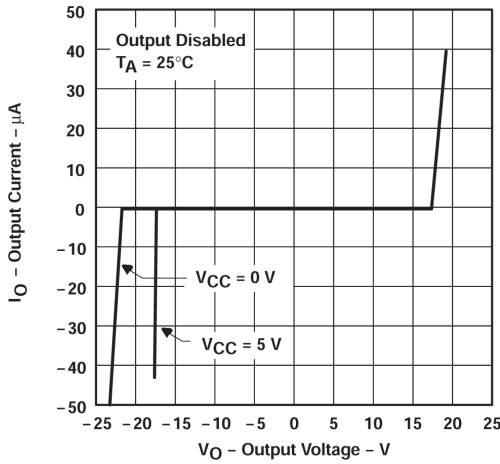

Figure 5-1. Output Current vs Output Voltage

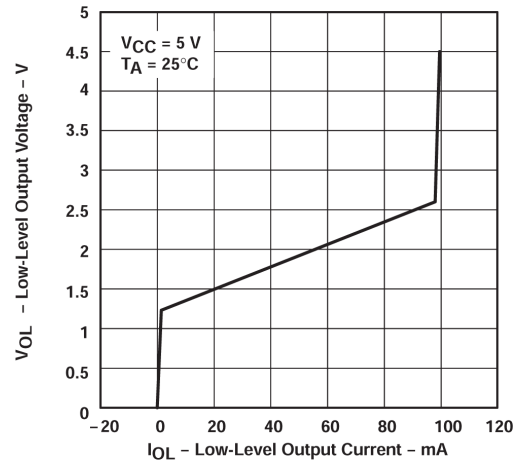

Figure 5-2. Low-level Output Voltage vs Low-level Output Current

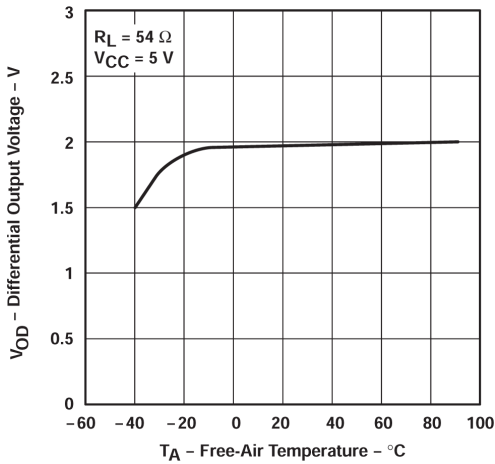

Figure 5-3. Differential Output Voltage vs Free-air Temperature

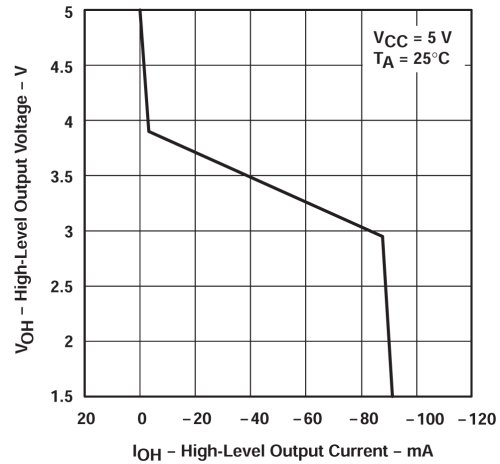

Figure 5-4. High-level Output Voltage vs High-level Output Current

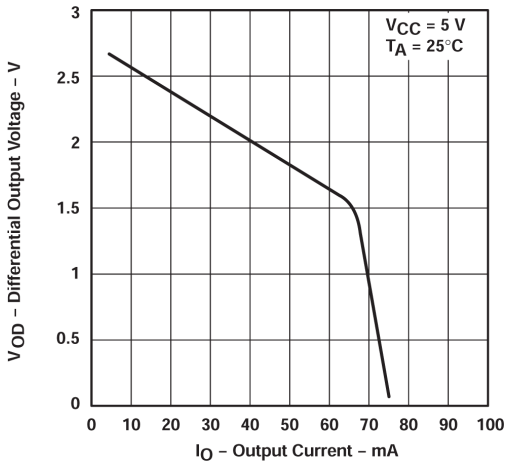

Figure 5-5. Differential Output Voltage vs Output Current

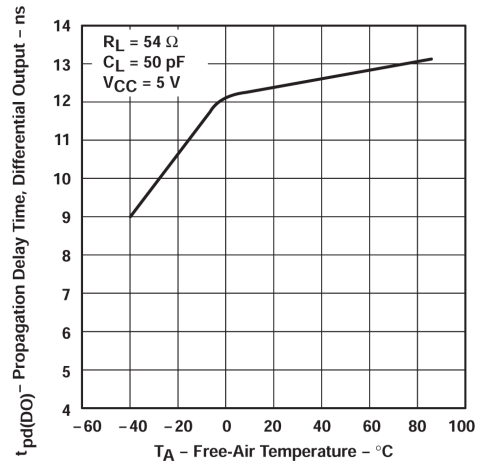

Figure 5-6. Propagation Delay Time, Differential Output vs Free-air Temperature

6 Parameter Measurement Information

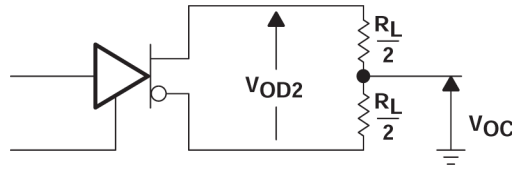
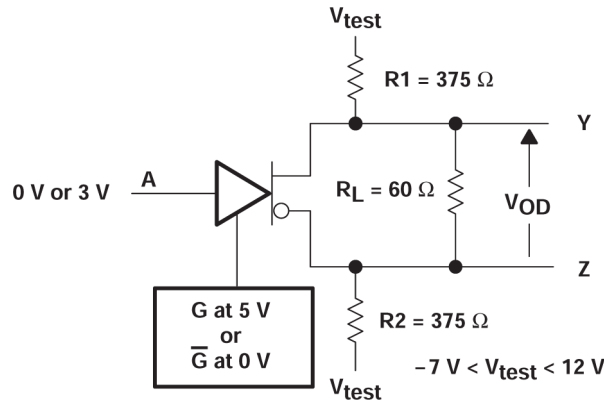
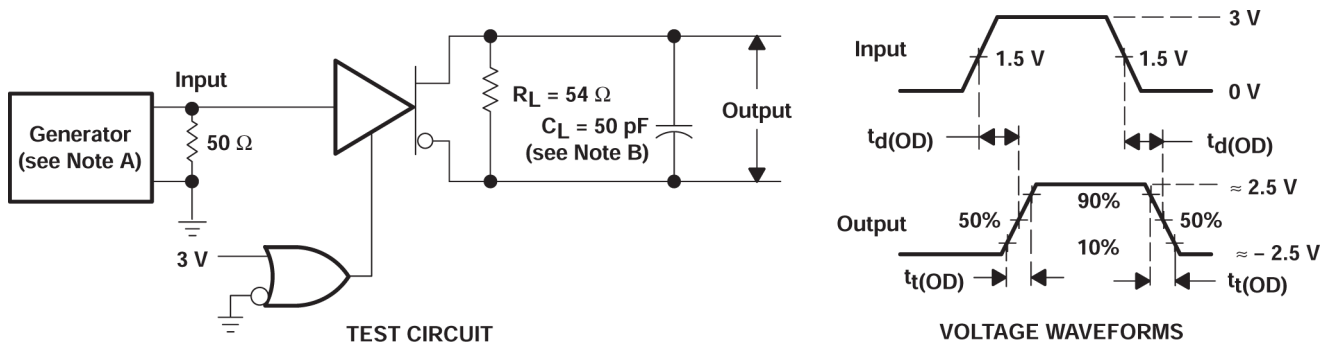

Figure 6-1. Differential and Common-Mode Output Voltages



- A. The input pulse is supplied by a generator having the following characteristics: PRR \leq 1 MHz, duty cycle = 50%, $t_r \leq$ 5 ns, $t_f \leq$ 5 ns, $Z_O = 50 \Omega$.
- B. C_L includes probe and stray capacitance.

Figure 6-2. Driver V_{OD} Test Circuit



- A. The input pulse is supplied by a generator having the following characteristics: PRR \leq 1 MHz, duty cycle = 50%, $t_r \leq$ 5 ns, $t_f \leq$ 5 ns, $Z_O = 50 \Omega$.
- B. C_L includes probe and stray capacitance.

Figure 6-3. Driver Differential-Output Test Circuit and Delay and Transition-Time Waveforms

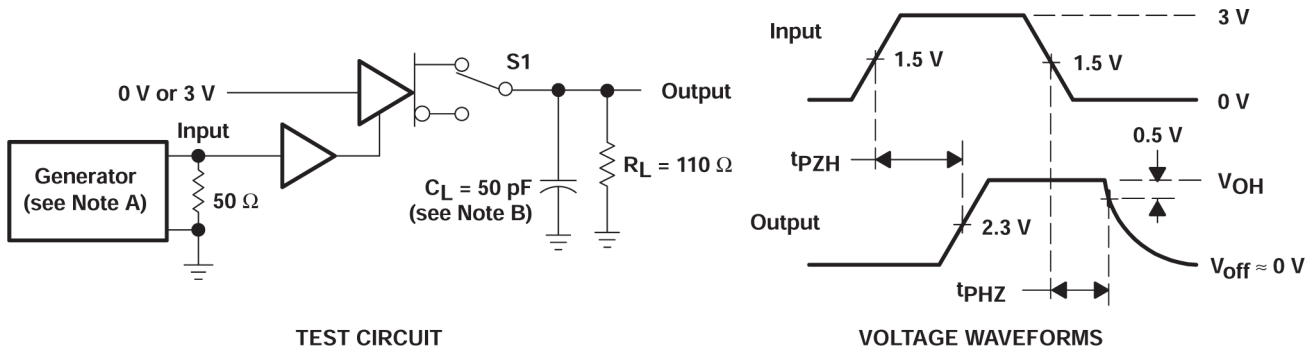

TEST CIRCUIT

VOLTAGE WAVEFORMS

- A. The input pulse is supplied by a generator having the following characteristics: PRR ≤ 1 MHz, duty cycle = 50%, $t_r \leq 5$ ns, $t_f \leq 5$ ns, $Z_O = 50 \Omega$.
- B. C_L includes probe and stray capacitance.

Figure 6-4. t_{pZH} and t_{pHZ} Test Circuit and Voltage Waveforms

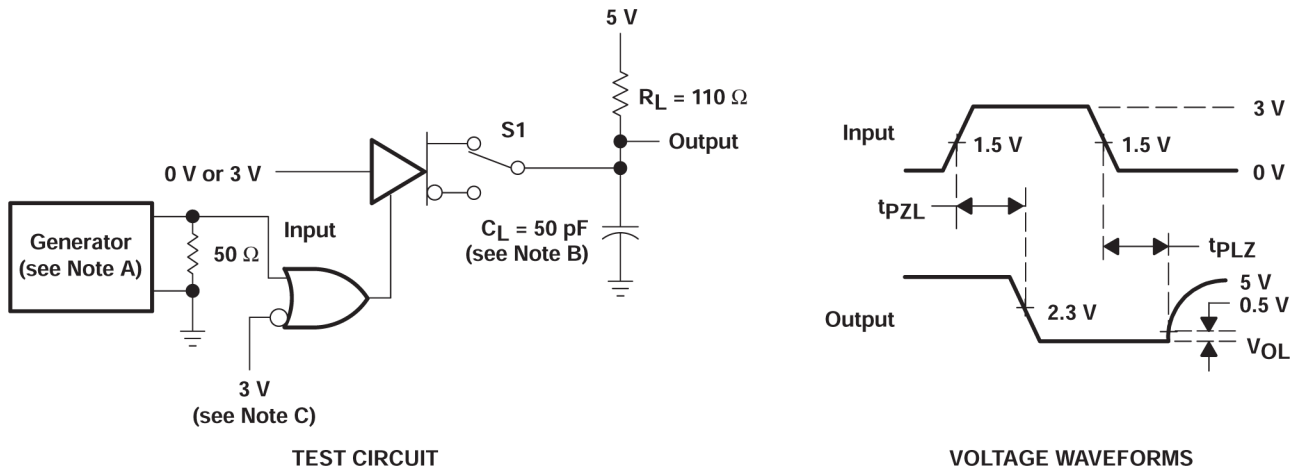

TEST CIRCUIT

VOLTAGE WAVEFORMS

- A. The input pulse is supplied by a generator having the following characteristics: PRR ≤ 1 MHz, duty cycle = 50%, $t_r \leq 5$ ns, $t_f \leq 5$ ns, $Z_O = 50 \Omega$.
- B. C_L includes probe and stray capacitance
- C. To test the active-low enable \overline{G} , ground G and apply an inverted waveform to \overline{G} .

Figure 6-5. t_{pZL} and t_{pLZ} Test Circuit and Waveforms

7 Detailed Description

7.1 Thermal Characteristics of Ic Packages

Θ_{JA} (Junction-to-Ambient Thermal Resistance) is defined as the difference in junction temperature to ambient temperature divided by the operating power

Θ_{JA} is NOT a constant and is a strong function of

- the PCB design (50% variation)
- altitude (20% variation)
- device power (5% variation)

Θ_{JA} can be used to compare the thermal performance of packages if the specific test conditions are defined and used. Standardized testing includes specification of PCB construction, test chamber volume, sensor locations, and the thermal characteristics of holding fixtures. Θ_{JA} is often misused when it is used to calculate junction temperatures for other installations.

TI uses two test PCBs as defined by JEDEC specifications. The low-k board gives *average* in-use condition thermal performance and consists of a single trace layer 25mm long and 2 oz thick copper. The high-k board gives *best case* in-use condition and consists of two 1-oz buried power planes with a single trace layer 25mm long with 2-oz thick copper. A 4% to 50% difference in Θ_{JA} can be measured between these two test cards

Θ_{JC} (Junction-to-Case Thermal Resistance) is defined as difference in junction temperature to case divided by the operating power. It is measured by putting the mounted package up against a copper block cold plate to force heat to flow from die, through the mold compound into the copper block.

Θ_{JC} is a useful thermal characteristic when a heatsink is applied to package. It is NOT a useful characteristic to predict junction temperature as it provides pessimistic numbers if the case temperature is measured in a non-standard system and junction temperatures are backed out. It can be used with Θ_{JB} in 1-dimensional thermal simulation of a package system.

Θ_{JB} (Junction-to-Board Thermal Resistance) is defined to be the difference in the junction temperature and the PCB temperature at the center of the package (closest to the die) when the PCB is clamped in a cold-plate structure. Θ_{JB} is only defined for the high-k test card.

Θ_{JB} provides an overall thermal resistance between the die and the PCB. Including a bit for the PCB thermal resistance (especially for BGAs with thermal balls), and can be used for simple 1-dimensional network analysis of package system (see [Figure 7-1](#)).

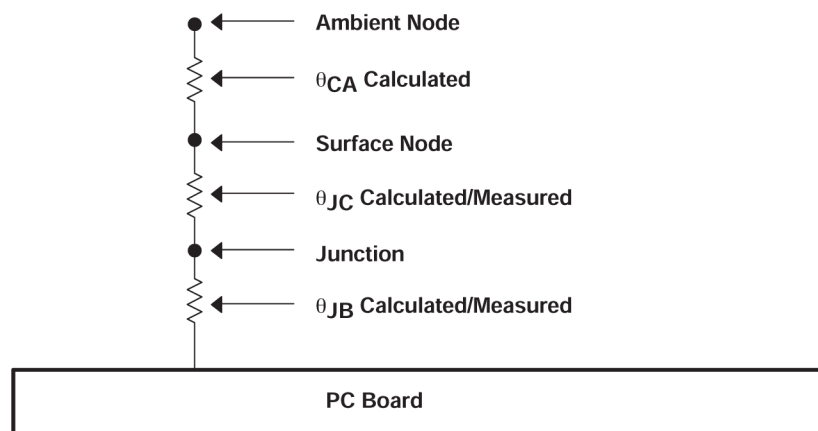

Figure 7-1. Thermal Resistance

7.2 Device Functional Modes

Table 7-1. Function Table (Each Driver)

INPUT A	ENABLES ⁽¹⁾		OUTPUTS	
	G	\bar{G}	Y	Z
H	H	X	H	L
L	H	X	L	H
H	X	L	H	L
L	X	L	L	H
X	L	H	Z	Z

(1) H = high level, L = low level, X = irrelevant, Z = high impedance (off)

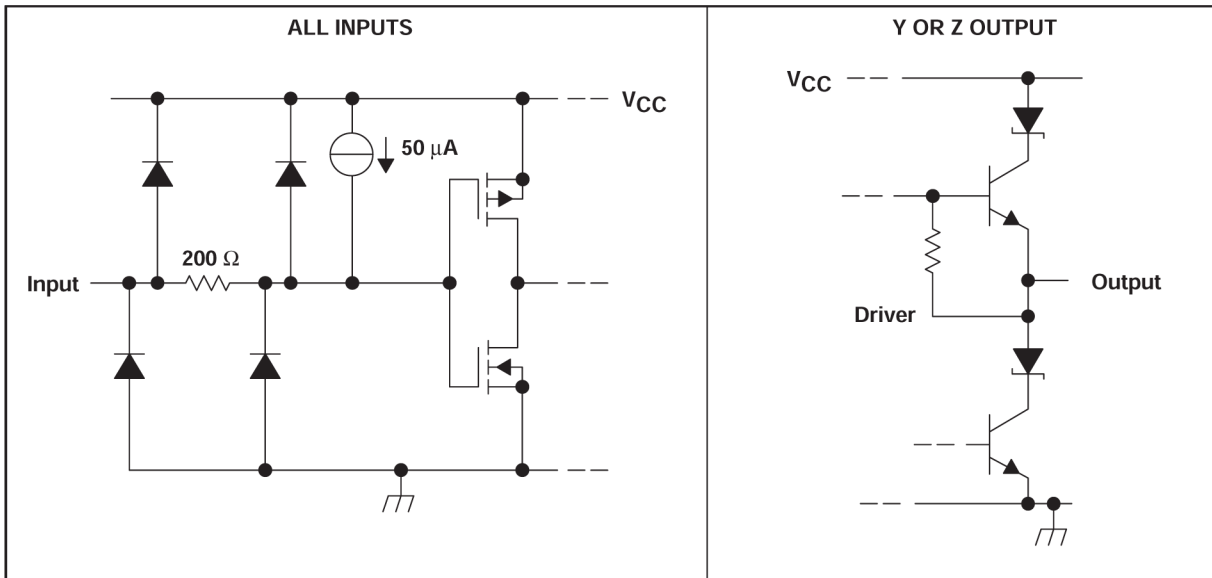

Figure 7-2. Schematic Diagrams of Inputs and Outputs

8 Device and Documentation Support

TI offers an extensive line of development tools. Tools and software to evaluate the performance of the device, generate code, and develop solutions are listed below.

8.1 Receiving Notification of Documentation Updates

To receive notification of documentation updates, navigate to the device product folder on ti.com. Click on *Notifications* to register and receive a weekly digest of any product information that has changed. For change details, review the revision history included in any revised document.

8.2 Support Resources

[TI E2E™ support forums](#) are an engineer's go-to source for fast, verified answers and design help — straight from the experts. Search existing answers or ask your own question to get the quick design help you need.

Linked content is provided "AS IS" by the respective contributors. They do not constitute TI specifications and do not necessarily reflect TI's views; see TI's [Terms of Use](#).

8.3 Trademarks

LinBiCMOS™ and TI E2E™ are trademarks of Texas Instruments. All trademarks are the property of their respective owners.

8.4 Electrostatic Discharge Caution



This integrated circuit can be damaged by ESD. Texas Instruments recommends that all integrated circuits be handled with appropriate precautions. Failure to observe proper handling and installation procedures can cause damage.

ESD damage can range from subtle performance degradation to complete device failure. Precision integrated circuits may be more susceptible to damage because very small parametric changes could cause the device not to meet its published specifications.

8.5 Glossary

[TI Glossary](#) This glossary lists and explains terms, acronyms, and definitions.

9 Revision History

NOTE: Page numbers for previous revisions may differ from page numbers in the current version.

Changes from Revision E (April 2006) to Revision F (April 2024)	Page
• Changed the numbering format for tables, figures, and cross-references throughout the document.....	1
• Added the <i>Thermal Information</i> table.....	6

10 Mechanical, Packaging, and Orderable Information

The following pages include mechanical, packaging, and orderable information. This information is the most current data available for the designated devices. This data is subject to change without notice and revision of this document. For browser-based versions of this data sheet, refer to the left-hand navigation.

PACKAGING INFORMATION

Orderable Device	Status (1)	Package Type	Package Drawing	Pins	Package Qty	Eco Plan (2)	Lead finish/ Ball material (6)	MSL Peak Temp (3)	Op Temp (°C)	Device Marking (4/5)	Samples
SN65LBC172DW	ACTIVE	SOIC	DW	20	25	RoHS & Green	NIPDAU	Level-1-260C-UNLIM	-40 to 85	SN65LBC172	Samples
SN65LBC172N	ACTIVE	PDIP	N	16	25	RoHS & Green	NIPDAU	N / A for Pkg Type	-40 to 85	SN65LBC172N	Samples
SN75LBC172DW	LIFEBUY	SOIC	DW	20	25	RoHS & Green	NIPDAU	Level-1-260C-UNLIM	0 to 70	SN75LBC172	
SN75LBC172DWR	ACTIVE	SOIC	DW	20	2000	RoHS & Green	NIPDAU	Level-1-260C-UNLIM	0 to 70	SN75LBC172	Samples
SN75LBC172N	ACTIVE	PDIP	N	16	25	RoHS & Green	NIPDAU	N / A for Pkg Type	0 to 70	SN75LBC172N	Samples

(1) The marketing status values are defined as follows:

ACTIVE: Product device recommended for new designs.

LIFEBUY: TI has announced that the device will be discontinued, and a lifetime-buy period is in effect.

NRND: Not recommended for new designs. Device is in production to support existing customers, but TI does not recommend using this part in a new design.

PREVIEW: Device has been announced but is not in production. Samples may or may not be available.

OBSOLETE: TI has discontinued the production of the device.

(2) **RoHS:** TI defines "RoHS" to mean semiconductor products that are compliant with the current EU RoHS requirements for all 10 RoHS substances, including the requirement that RoHS substance do not exceed 0.1% by weight in homogeneous materials. Where designed to be soldered at high temperatures, "RoHS" products are suitable for use in specified lead-free processes. TI may reference these types of products as "Pb-Free".

RoHS Exempt: TI defines "RoHS Exempt" to mean products that contain lead but are compliant with EU RoHS pursuant to a specific EU RoHS exemption.

Green: TI defines "Green" to mean the content of Chlorine (Cl) and Bromine (Br) based flame retardants meet JS709B low halogen requirements of <=1000ppm threshold. Antimony trioxide based flame retardants must also meet the <=1000ppm threshold requirement.

(3) MSL, Peak Temp. - The Moisture Sensitivity Level rating according to the JEDEC industry standard classifications, and peak solder temperature.

(4) There may be additional marking, which relates to the logo, the lot trace code information, or the environmental category on the device.

(5) Multiple Device Markings will be inside parentheses. Only one Device Marking contained in parentheses and separated by a "~" will appear on a device. If a line is indented then it is a continuation of the previous line and the two combined represent the entire Device Marking for that device.

(6) Lead finish/Ball material - Orderable Devices may have multiple material finish options. Finish options are separated by a vertical ruled line. Lead finish/Ball material values may wrap to two lines if the finish value exceeds the maximum column width.

Important Information and Disclaimer: The information provided on this page represents TI's knowledge and belief as of the date that it is provided. TI bases its knowledge and belief on information provided by third parties, and makes no representation or warranty as to the accuracy of such information. Efforts are underway to better integrate information from third parties. TI has taken and

continues to take reasonable steps to provide representative and accurate information but may not have conducted destructive testing or chemical analysis on incoming materials and chemicals. TI and TI suppliers consider certain information to be proprietary, and thus CAS numbers and other limited information may not be available for release.

In no event shall TI's liability arising out of such information exceed the total purchase price of the TI part(s) at issue in this document sold by TI to Customer on an annual basis.

OTHER QUALIFIED VERSIONS OF SN75LBC172 :

- Military : [SN55LBC172](#)

NOTE: Qualified Version Definitions:

- Military - QML certified for Military and Defense Applications

TAPE AND REEL INFORMATION

QUADRANT ASSIGNMENTS FOR PIN 1 ORIENTATION IN TAPE

*All dimensions are nominal

Device	Package Type	Package Drawing	Pins	SPQ	Reel Diameter (mm)	Reel Width W1 (mm)	A0 (mm)	B0 (mm)	K0 (mm)	P1 (mm)	W (mm)	Pin1 Quadrant
SN75LBC172DWR	SOIC	DW	20	2000	330.0	24.4	10.8	13.3	2.7	12.0	24.0	Q1

TAPE AND REEL BOX DIMENSIONS

*All dimensions are nominal

Device	Package Type	Package Drawing	Pins	SPQ	Length (mm)	Width (mm)	Height (mm)
SN75LBC172DWR	SOIC	DW	20	2000	367.0	367.0	45.0

TUBE

*All dimensions are nominal

Device	Package Name	Package Type	Pins	SPQ	L (mm)	W (mm)	T (μm)	B (mm)
SN65LBC172DW	DW	SOIC	20	25	507	12.83	5080	6.6
SN65LBC172DW	DW	SOIC	20	25	506.98	12.7	4826	6.6
SN65LBC172N	N	PDIP	16	25	506	13.97	11230	4.32
SN75LBC172DW	DW	SOIC	20	25	507	12.83	5080	6.6
SN75LBC172DW	DW	SOIC	20	25	506.98	12.7	4826	6.6
SN75LBC172N	N	PDIP	16	25	506	13.97	11230	4.32

N (R-PDIP-T**)

PLASTIC DUAL-IN-LINE PACKAGE

16 PINS SHOWN



4040049/E 12/2002

- NOTES:
- A. All linear dimensions are in inches (millimeters).
 - B. This drawing is subject to change without notice.
 - (C) Falls within JEDEC MS-001, except 18 and 20 pin minimum body length (Dim A).
 - (D) The 20 pin end lead shoulder width is a vendor option, either half or full width.

DW0020A



PACKAGE OUTLINE

SOIC - 2.65 mm max height

SOIC



4220724/A 05/2016

NOTES:

1. All linear dimensions are in millimeters. Dimensions in parenthesis are for reference only. Dimensioning and tolerancing per ASME Y14.5M.
2. This drawing is subject to change without notice.
3. This dimension does not include mold flash, protrusions, or gate burrs. Mold flash, protrusions, or gate burrs shall not exceed 0.15 mm per side.
4. This dimension does not include interlead flash. Interlead flash shall not exceed 0.43 mm per side.
5. Reference JEDEC registration MS-013.

EXAMPLE BOARD LAYOUT

DW0020A

SOIC - 2.65 mm max height

SOIC



LAND PATTERN EXAMPLE
SCALE:6X



SOLDER MASK DETAILS

4220724/A 05/2016

NOTES: (continued)

- 6. Publication IPC-7351 may have alternate designs.
- 7. Solder mask tolerances between and around signal pads can vary based on board fabrication site.

EXAMPLE STENCIL DESIGN

DW0020A

SOIC - 2.65 mm max height

SOIC



SOLDER PASTE EXAMPLE
BASED ON 0.125 mm THICK STENCIL
SCALE:6X

4220724/A 05/2016

NOTES: (continued)

8. Laser cutting apertures with trapezoidal walls and rounded corners may offer better paste release. IPC-7525 may have alternate design recommendations.
9. Board assembly site may have different recommendations for stencil design.

IMPORTANT NOTICE AND DISCLAIMER

TI PROVIDES TECHNICAL AND RELIABILITY DATA (INCLUDING DATA SHEETS), DESIGN RESOURCES (INCLUDING REFERENCE DESIGNS), APPLICATION OR OTHER DESIGN ADVICE, WEB TOOLS, SAFETY INFORMATION, AND OTHER RESOURCES "AS IS" AND WITH ALL FAULTS, AND DISCLAIMS ALL WARRANTIES, EXPRESS AND IMPLIED, INCLUDING WITHOUT LIMITATION ANY IMPLIED WARRANTIES OF MERCHANTABILITY, FITNESS FOR A PARTICULAR PURPOSE OR NON-INFRINGEMENT OF THIRD PARTY INTELLECTUAL PROPERTY RIGHTS.

These resources are intended for skilled developers designing with TI products. You are solely responsible for (1) selecting the appropriate TI products for your application, (2) designing, validating and testing your application, and (3) ensuring your application meets applicable standards, and any other safety, security, regulatory or other requirements.

These resources are subject to change without notice. TI grants you permission to use these resources only for development of an application that uses the TI products described in the resource. Other reproduction and display of these resources is prohibited. No license is granted to any other TI intellectual property right or to any third party intellectual property right. TI disclaims responsibility for, and you will fully indemnify TI and its representatives against, any claims, damages, costs, losses, and liabilities arising out of your use of these resources.

TI's products are provided subject to [TI's Terms of Sale](#) or other applicable terms available either on [ti.com](https://www.ti.com) or provided in conjunction with such TI products. TI's provision of these resources does not expand or otherwise alter TI's applicable warranties or warranty disclaimers for TI products.

TI objects to and rejects any additional or different terms you may have proposed.

Mailing Address: Texas Instruments, Post Office Box 655303, Dallas, Texas 75265
Copyright © 2024, Texas Instruments Incorporated

Looking for pricing, stock, or lifecycle information?

Click below to explore more details on WIN SOURCE:

 [View SN65LBC172N on WIN SOURCE](#)

 [Texas Instruments](#) Information

Optimize Your Supply Chain with WIN SOURCE Solutions

-  Global Sourcing Solution
-  Obsolete Management
-  Cost Control Management
-  Shortage Management
-  Alternative Solution
-  Excess Inventory Management