



**THE DATASHEET OF  
SN74ALS323N**





# SN54ALS323, SN74ALS323

## 8-BIT UNIVERSAL SHIFT/STORAGE REGISTERS

### WITH SYNCHRONOUS CLEAR AND 3-STATE OUTPUTS

SDAS267A – DECEMBER 1982 – REVISED DECEMBER 1994

FUNCTION TABLE

MODE	INPUTS								I/O PORTS								OUTPUTS	
	$\overline{\text{CLR}}$	S1	S0	$\overline{\text{OE1}}^\dagger$	$\overline{\text{OE2}}^\dagger$	CLK	SL	SR	A/Q <sub>A</sub>	B/Q <sub>B</sub>	C/Q <sub>C</sub>	D/Q <sub>D</sub>	E/Q <sub>E</sub>	F/Q <sub>F</sub>	G/Q <sub>G</sub>	H/Q <sub>H</sub>	Q <sub>A</sub> '	Q <sub>H</sub> '
Clear	L	X	L	L	L	↑	X	X	L	L	L	L	L	L	L	L	L	L
	L	L	X	L	L	↑	X	X	L	L	L	L	L	L	L	L	L	L
	L	H	H	X	X	↑	X	X	X	X	X	X	X	X	X	X	L	L
Hold	H	L	L	L	L	X	X	X	Q <sub>A0</sub>	Q <sub>B0</sub>	Q <sub>C0</sub>	Q <sub>D0</sub>	Q <sub>E0</sub>	Q <sub>F0</sub>	Q <sub>G0</sub>	Q <sub>H0</sub>	Q <sub>A0</sub>	Q <sub>H0</sub>
	H	X	X	L	L	L	X	X	Q <sub>A0</sub>	Q <sub>B0</sub>	Q <sub>C0</sub>	Q <sub>D0</sub>	Q <sub>E0</sub>	Q <sub>F0</sub>	Q <sub>G0</sub>	Q <sub>H0</sub>	Q <sub>A0</sub>	Q <sub>H0</sub>
Shift Right	H	L	H	L	L	↑	X	H	H	Q <sub>An</sub>	Q <sub>Bn</sub>	Q <sub>Cn</sub>	Q <sub>Dn</sub>	Q <sub>En</sub>	Q <sub>Fn</sub>	Q <sub>Gn</sub>	H	Q <sub>Gn</sub>
	H	L	H	L	L	↑	X	L	L	Q <sub>An</sub>	Q <sub>Bn</sub>	Q <sub>Cn</sub>	Q <sub>Dn</sub>	Q <sub>En</sub>	Q <sub>Fn</sub>	Q <sub>Gn</sub>	L	Q <sub>Gn</sub>
Shift Left	H	H	L	L	L	↑	H	X	Q <sub>Bn</sub>	Q <sub>Cn</sub>	Q <sub>Dn</sub>	Q <sub>En</sub>	Q <sub>Fn</sub>	Q <sub>Gn</sub>	Q <sub>Hn</sub>	H	Q <sub>Bn</sub>	H
	H	H	L	L	L	↑	L	X	Q <sub>Bn</sub>	Q <sub>Cn</sub>	Q <sub>Dn</sub>	Q <sub>En</sub>	Q <sub>Fn</sub>	Q <sub>Gn</sub>	Q <sub>Hn</sub>	L	Q <sub>Bn</sub>	L
Load	H	H	H	X	X	↑	X	X	a	b	c	d	e	f	g	h	a	h

NOTE: a . . . h = the level of the steady-state input at inputs A through H, respectively. This data is loaded into the flip-flops while the flip-flop outputs are isolated from the I/O terminals.

† When one or both output-enable inputs are high, the eight I/O terminals are disabled to the high-impedance state; however, sequential operation or clearing of the register is not affected.

### logic symbol†

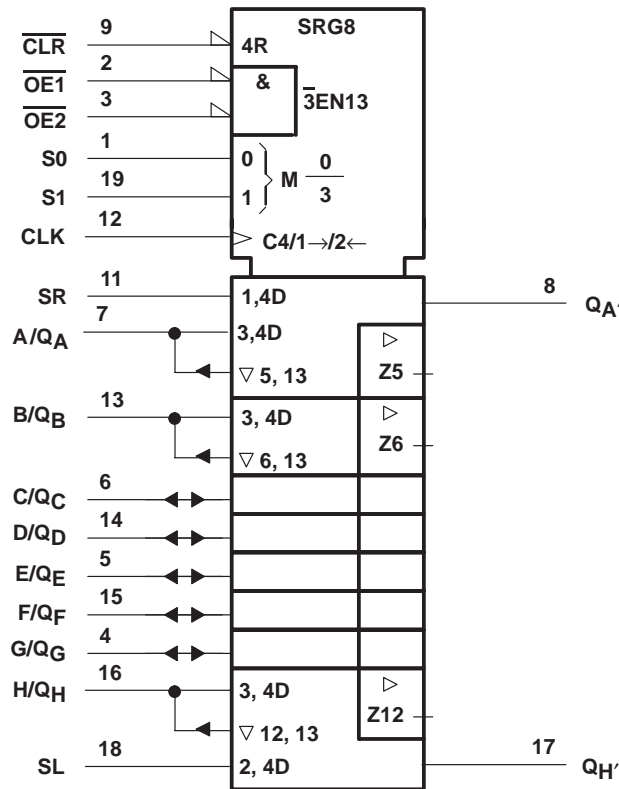

† This symbol is in accordance with ANSI/IEEE Std 91-1984 and IEC Publication 617-12.



# SN54ALS323, SN74ALS323 8-BIT UNIVERSAL SHIFT/STORAGE REGISTERS WITH SYNCHRONOUS CLEAR AND 3-STATE OUTPUTS

SDAS267A – DECEMBER 1982 – REVISED DECEMBER 1994

## logic diagram (positive logic)

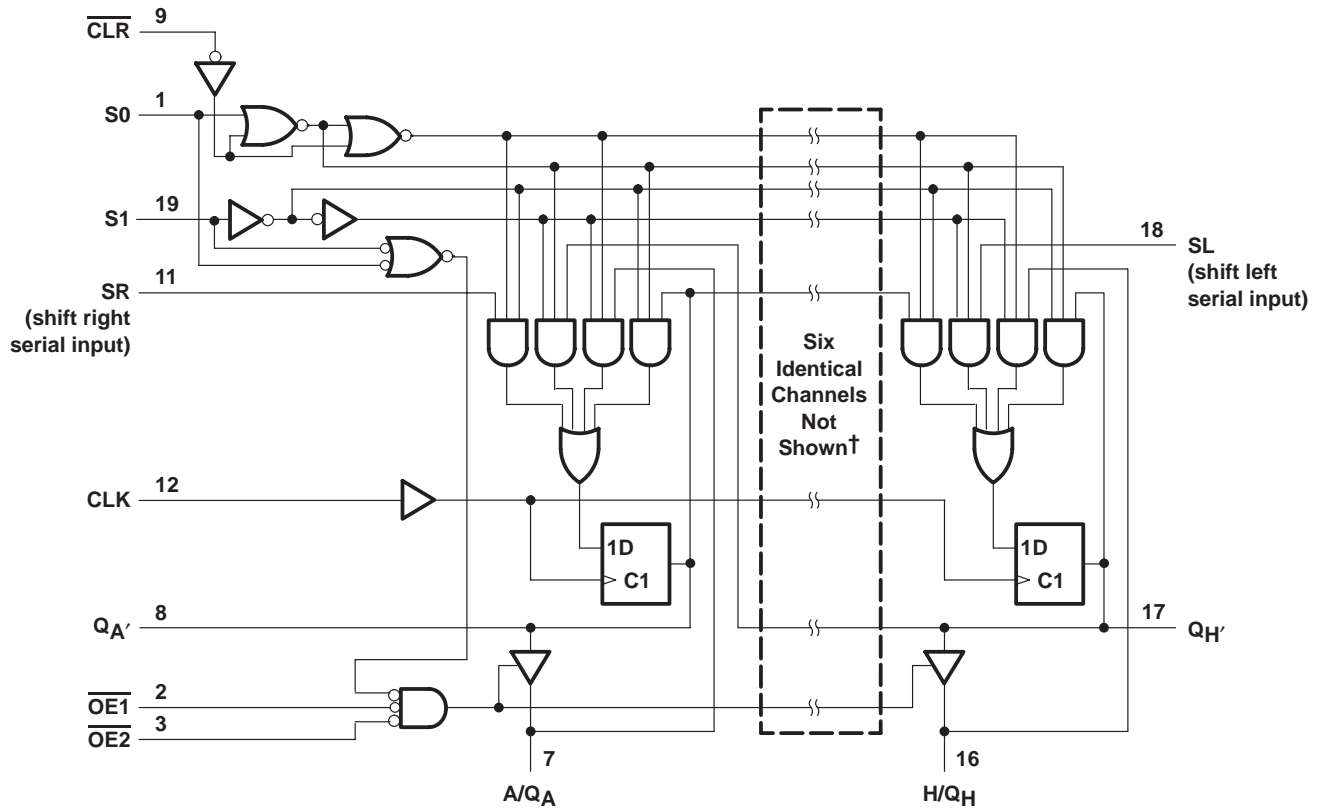

† I/O ports not shown: B/Q<sub>B</sub> (13), C/Q<sub>C</sub> (6), D/Q<sub>D</sub> (14), E/Q<sub>E</sub> (5), F/Q<sub>F</sub> (15), and G/Q<sub>G</sub> (4).

## absolute maximum ratings over operating free-air temperature range (unless otherwise noted)‡

Supply voltage, $V_{CC}$	7 V
Input voltage, $V_I$ : All inputs	7 V
I/O ports	5.5 V
Operating free-air temperature range, $T_A$ : SN54ALS323	-55°C to 125°C
SN74ALS323	0°C to 70°C
Storage temperature range	-65°C to 150°C

‡ Stresses beyond those listed under "absolute maximum ratings" may cause permanent damage to the device. These are stress ratings only, and functional operation of the device at these or any other conditions beyond those indicated under "recommended operating conditions" is not implied. Exposure to absolute-maximum-rated conditions for extended periods may affect device reliability.



# SN54ALS323, SN74ALS323

## 8-BIT UNIVERSAL SHIFT/STORAGE REGISTERS

### WITH SYNCHRONOUS CLEAR AND 3-STATE OUTPUTS

SDAS267A – DECEMBER 1982 – REVISED DECEMBER 1994

#### recommended operating conditions

		SN54ALS323			SN74ALS323			UNIT
		MIN	NOM	MAX	MIN	NOM	MAX	
$V_{CC}$	Supply voltage	4.5	5	5.5	4.5	5	5.5	V
$V_{IH}$	High-level input voltage	2			2			V
$V_{IL}$	Low-level input voltage			0.7			0.8	V
$I_{OH}$	High-level output current	$Q_A'$ or $Q_H'$		-0.4			-0.4	mA
		$Q_A$ thru $Q_H$		-1			-2.6	
$I_{OL}$	Low-level output current	$Q_A'$ or $Q_H'$		4			8	mA
		$Q_A$ thru $Q_H$		12			24	
$T_A$	Operating free-air temperature	-55		125	0		70	°C

#### electrical characteristics over recommended operating free-air temperature range (unless otherwise noted)

PARAMETER		TEST CONDITIONS		SN54ALS323			SN74ALS323			UNIT
				MIN	TYP†	MAX	MIN	TYP†	MAX	
$V_{IK}$		$V_{CC} = 4.5\text{ V}$ ,	$I_I = -18\text{ mA}$			-1.5			-1.5	V
$V_{OH}$	Any output	$V_{CC} = 4.5\text{ V to }5.5\text{ V}$ ,	$I_{OH} = -0.4\text{ mA}$	$V_{CC} - 2$		$V_{CC} - 2$				V
	$Q_A$ thru $Q_H$	$V_{CC} = 4.5\text{ V}$	$I_{OH} = -1\text{ mA}$	2.4	3.3					
$V_{OL}$	$Q_A'$ or $Q_H'$	$V_{CC} = 4.5\text{ V}$	$I_{OL} = 4\text{ mA}$	0.25	0.4	0.25	0.4			V
			$I_{OL} = 8\text{ mA}$			0.35	0.5			
	$Q_A$ thru $Q_H$	$V_{CC} = 4.5\text{ V}$	$I_{OL} = 12\text{ mA}$	0.25	0.4	0.25	0.4			
			$I_{OL} = 24\text{ mA}$			0.35	0.5			
$I_I$	A thru H	$V_{CC} = 5.5\text{ V}$	$V_I = 5.5\text{ V}$			0.1			0.1	mA
	Any others		$V_I = 7\text{ V}$			0.1			0.1	
$I_{IH}^\ddagger$		$V_{CC} = 5.5\text{ V}$ ,	$V_I = 2.7\text{ V}$			20			20	μA
$I_{IL}^\ddagger$	S0, S1, SR, SL	$V_{CC} = 5.5\text{ V}$ ,	$V_I = 0.4\text{ V}$			-0.2			-0.2	mA
	Any others					-0.1			-0.1	
$I_{OS}^\S$	$Q_A'$ or $Q_H'$	$V_{CC} = 5.5\text{ V}$ ,	$V_O = 2.25\text{ V}$	-15	-70	-15	-70			mA
	$Q_A$ thru $Q_H$			-20	-112	-30	-112			
$I_{CC}$		$V_{CC} = 5.5\text{ V}$	Outputs high	15	28	15	28			mA
			Outputs low	22	38	22	38			
			Outputs disabled	23	40	23	40			

† All typical values are at  $V_{CC} = 5\text{ V}$ ,  $T_A = 25^\circ\text{C}$ .

‡ For I/O ports ( $Q_A$  thru  $Q_H$ ), the parameters  $I_{IH}$  and  $I_{IL}$  include the off-state output current.

§ The output conditions have been chosen to produce a current that closely approximates one half of the true short-circuit output current,  $I_{OS}$ .



# SN54ALS323, SN74ALS323 8-BIT UNIVERSAL SHIFT/STORAGE REGISTERS WITH SYNCHRONOUS CLEAR AND 3-STATE OUTPUTS

SDAS267A – DECEMBER 1982 – REVISED DECEMBER 1994

timing requirements over recommended ranges of supply voltage and operating free-air temperature (unless otherwise noted)

			SN54ALS323		SN74ALS323		UNIT
			MIN	MAX	MIN	MAX	
$f_{\text{clock}}$	Clock frequency (at 50% duty cycle)		0	17	0	17	MHz
$t_w$	Pulse duration		CLK high or low		22	16.5	ns
$t_{\text{su}}$	Setup time before CLK $\uparrow$	S0 or S1	25		20		ns
		Serial or parallel data	High	18		16	
			Low	15		6	
	$\overline{\text{CLR}}$ active	25		20			
	Inactive-state setup time before CLK $\uparrow$	$\overline{\text{CLR}}$	18		16		
$t_h$	Hold time after CLK $\uparrow$	S0 or S1	0		0		ns
		Serial or parallel data	0		0		

† Inactive-state setup time is also referred to as recovery time.

## switching characteristics (see Figure 1)

PARAMETER	FROM (INPUT)	TO (OUTPUT)	$V_{\text{CC}} = 4.5 \text{ V to } 5.5 \text{ V},$ $C_L = 50 \text{ pF},$ $R_1 = 500 \Omega,$ $R_2 = 500 \Omega,$ $T_A = \text{MIN to MAX}^\ddagger$				UNIT
			SN54ALS323		SN74ALS323		
			MIN	MAX	MIN	MAX	
$f_{\text{max}}$			17		17		MHz
$t_{\text{PLH}}$	CLK	$Q_A$ thru $Q_H$	2	19	4	13	ns
$t_{\text{PHL}}$			4	25	7	19	
$t_{\text{PLH}}$	CLK	$Q_{A'}$ or $Q_{H'}$	2	21	5	15	ns
$t_{\text{PHL}}$			4	25	8	18	
$t_{\text{PZH}}$	$\overline{\text{OE1}}, \overline{\text{OE2}}$	$Q_A$ thru $Q_H$	5	22	6	16	ns
$t_{\text{PZL}}$			6	27	8	22	
$t_{\text{PZH}}$	S0, S1	$Q_A$ thru $Q_H$	5	27	7	17	ns
$t_{\text{PZL}}$			6	27	8	22	
$t_{\text{PHZ}}$	$\overline{\text{OE1}}, \overline{\text{OE2}}$	$Q_A$ thru $Q_H$	1	15	1	8	ns
$t_{\text{PLZ}}$			4	38	5	15	
$t_{\text{PHZ}}$	S0, S1	$Q_A$ thru $Q_H$	1	16	1	12	ns
$t_{\text{PLZ}}$			4	34	8	25	

‡ For conditions shown as MIN or MAX, use the appropriate value specified under recommended operating conditions.



# SN54ALS323, SN74ALS323 8-BIT UNIVERSAL SHIFT/STORAGE REGISTERS WITH SYNCHRONOUS CLEAR AND 3-STATE OUTPUTS

SDAS267A – DECEMBER 1982 – REVISED DECEMBER 1994

## PARAMETER MEASUREMENT INFORMATION SERIES 54ALS/74ALS AND 54AS/74AS DEVICES

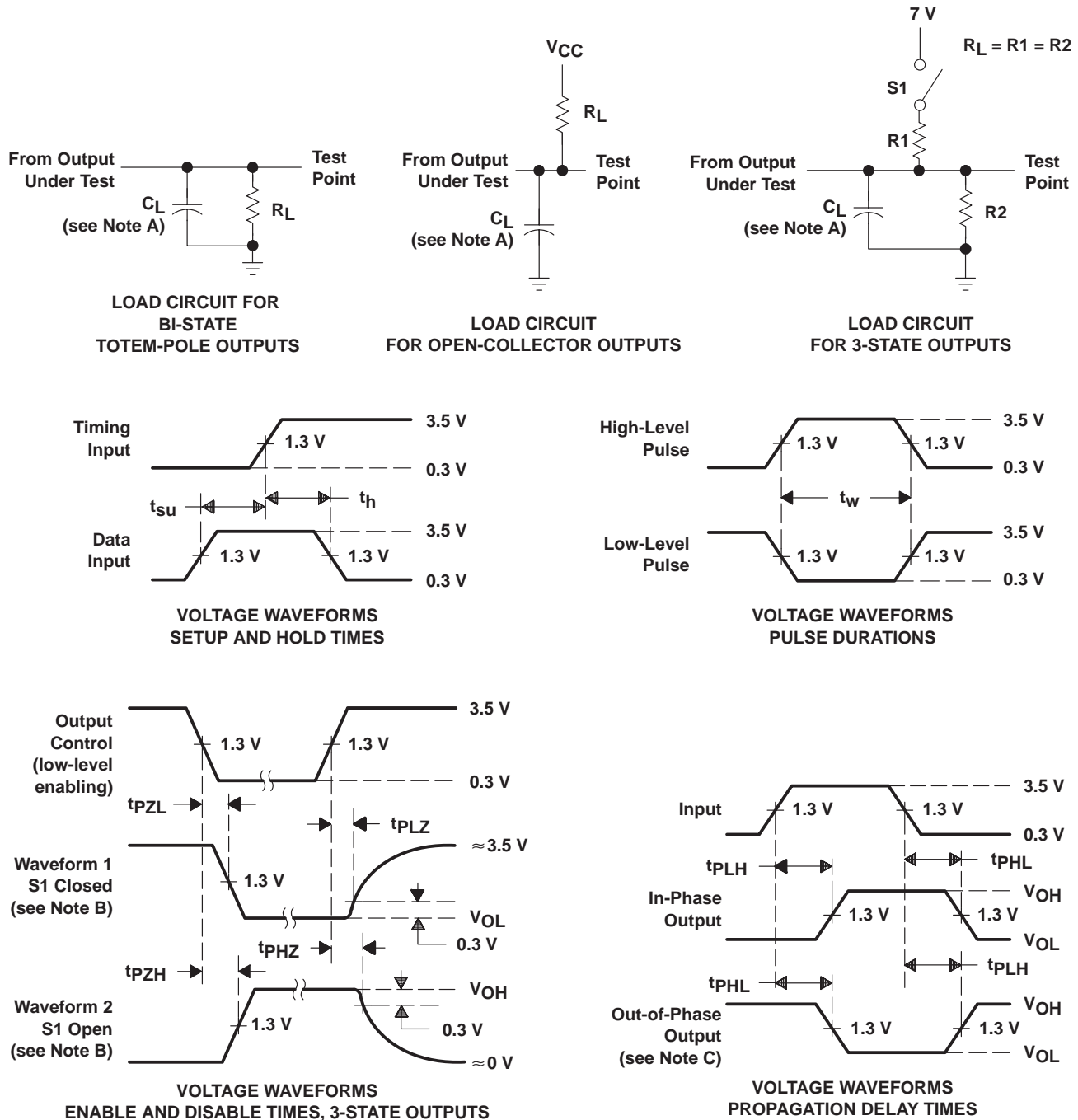

- NOTES: A.  $C_L$  includes probe and jig capacitance.  
 B. Waveform 1 is for an output with internal conditions such that the output is low except when disabled by the output control. Waveform 2 is for an output with internal conditions such that the output is high except when disabled by the output control.  
 C. When measuring propagation delay items of 3-state outputs, switch S1 is open.  
 D. All input pulses have the following characteristics:  $PRR \leq 1$  MHz,  $t_r = t_f = 2$  ns, duty cycle = 50%.  
 E. The outputs are measured one at a time with one transition per measurement.

Figure 1. Load Circuits and Voltage Waveforms



**PACKAGING INFORMATION**

Orderable Device	Status (1)	Package Type	Package Drawing	Pins	Package Qty	Eco Plan (2)	Lead finish/ Ball material (6)	MSL Peak Temp (3)	Op Temp (°C)	Device Marking (4/5)	Samples
8302102RA	ACTIVE	CDIP	J	20	20	Non-RoHS & Green	SNPB	N / A for Pkg Type	-55 to 125	8302102RA SNJ54ALS323J	<a href="#">Samples</a>
8302102SA	ACTIVE	CFP	W	20	25	Non-RoHS & Green	SNPB	N / A for Pkg Type	-55 to 125	8302102SA SNJ54ALS323W	<a href="#">Samples</a>
SN74ALS323N	ACTIVE	PDIP	N	20	20	RoHS & Non-Green	NIPDAU	N / A for Pkg Type	0 to 70	SN74ALS323N	<a href="#">Samples</a>
SNJ54ALS323J	ACTIVE	CDIP	J	20	20	Non-RoHS & Green	SNPB	N / A for Pkg Type	-55 to 125	8302102RA SNJ54ALS323J	<a href="#">Samples</a>
SNJ54ALS323W	ACTIVE	CFP	W	20	25	Non-RoHS & Green	SNPB	N / A for Pkg Type	-55 to 125	8302102SA SNJ54ALS323W	<a href="#">Samples</a>

(1) The marketing status values are defined as follows:

**ACTIVE:** Product device recommended for new designs.

**LIFEBUY:** TI has announced that the device will be discontinued, and a lifetime-buy period is in effect.

**NRND:** Not recommended for new designs. Device is in production to support existing customers, but TI does not recommend using this part in a new design.

**PREVIEW:** Device has been announced but is not in production. Samples may or may not be available.

**OBSOLETE:** TI has discontinued the production of the device.

(2) **RoHS:** TI defines "RoHS" to mean semiconductor products that are compliant with the current EU RoHS requirements for all 10 RoHS substances, including the requirement that RoHS substance do not exceed 0.1% by weight in homogeneous materials. Where designed to be soldered at high temperatures, "RoHS" products are suitable for use in specified lead-free processes. TI may reference these types of products as "Pb-Free".

**RoHS Exempt:** TI defines "RoHS Exempt" to mean products that contain lead but are compliant with EU RoHS pursuant to a specific EU RoHS exemption.

**Green:** TI defines "Green" to mean the content of Chlorine (Cl) and Bromine (Br) based flame retardants meet JS709B low halogen requirements of <=1000ppm threshold. Antimony trioxide based flame retardants must also meet the <=1000ppm threshold requirement.

(3) MSL, Peak Temp. - The Moisture Sensitivity Level rating according to the JEDEC industry standard classifications, and peak solder temperature.

(4) There may be additional marking, which relates to the logo, the lot trace code information, or the environmental category on the device.

(5) Multiple Device Markings will be inside parentheses. Only one Device Marking contained in parentheses and separated by a "-" will appear on a device. If a line is indented then it is a continuation of the previous line and the two combined represent the entire Device Marking for that device.

(6) Lead finish/Ball material - Orderable Devices may have multiple material finish options. Finish options are separated by a vertical ruled line. Lead finish/Ball material values may wrap to two lines if the finish value exceeds the maximum column width.

**Important Information and Disclaimer:**The information provided on this page represents TI's knowledge and belief as of the date that it is provided. TI bases its knowledge and belief on information provided by third parties, and makes no representation or warranty as to the accuracy of such information. Efforts are underway to better integrate information from third parties. TI has taken and continues to take reasonable steps to provide representative and accurate information but may not have conducted destructive testing or chemical analysis on incoming materials and chemicals. TI and TI suppliers consider certain information to be proprietary, and thus CAS numbers and other limited information may not be available for release.

In no event shall TI's liability arising out of such information exceed the total purchase price of the TI part(s) at issue in this document sold by TI to Customer on an annual basis.

**OTHER QUALIFIED VERSIONS OF SN54ALS323, SN74ALS323 :**

- Catalog : [SN74ALS323](#)
- Military : [SN54ALS323](#)

NOTE: Qualified Version Definitions:

- Catalog - TI's standard catalog product
- Military - QML certified for Military and Defense Applications

**TUBE**

\*All dimensions are nominal

Device	Package Name	Package Type	Pins	SPQ	L (mm)	W (mm)	T (μm)	B (mm)
8302102SA	W	CFP	20	25	506.98	26.16	6220	NA
SN74ALS323N	N	PDIP	20	20	506	13.97	11230	4.32
SNJ54ALS323W	W	CFP	20	25	506.98	26.16	6220	NA

W (R-GDFP-F20)

CERAMIC DUAL FLATPACK



- NOTES:
- A. All linear dimensions are in inches (millimeters).
  - B. This drawing is subject to change without notice.
  - C. This package can be hermetically sealed with a ceramic lid using glass frit.
  - D. Index point is provided on cap for terminal identification only.
  - E. Falls within Mil-Std 1835 GDFP2-F20

J (R-GDIP-T\*\*)

14 LEADS SHOWN

CERAMIC DUAL IN-LINE PACKAGE



DIM \ PINS **	14	16	18	20
A	0.300 (7,62) BSC	0.300 (7,62) BSC	0.300 (7,62) BSC	0.300 (7,62) BSC
B MAX	0.785 (19,94)	.840 (21,34)	0.960 (24,38)	1.060 (26,92)
B MIN	—	—	—	—
C MAX	0.300 (7,62)	0.300 (7,62)	0.310 (7,87)	0.300 (7,62)
C MIN	0.245 (6,22)	0.245 (6,22)	0.220 (5,59)	0.245 (6,22)



4040083/F 03/03

- NOTES:
- All linear dimensions are in inches (millimeters).
  - This drawing is subject to change without notice.
  - This package is hermetically sealed with a ceramic lid using glass frit.
  - Index point is provided on cap for terminal identification only on press ceramic glass frit seal only.
  - Falls within MIL STD 1835 GDIP1-T14, GDIP1-T16, GDIP1-T18 and GDIP1-T20.

N (R-PDIP-T\*\*)

PLASTIC DUAL-IN-LINE PACKAGE

16 PINS SHOWN



- NOTES:
- A. All linear dimensions are in inches (millimeters).
  - B. This drawing is subject to change without notice.
  - Falls within JEDEC MS-001, except 18 and 20 pin minimum body length (Dim A).
  - The 20 pin end lead shoulder width is a vendor option, either half or full width.

## IMPORTANT NOTICE AND DISCLAIMER

TI PROVIDES TECHNICAL AND RELIABILITY DATA (INCLUDING DATA SHEETS), DESIGN RESOURCES (INCLUDING REFERENCE DESIGNS), APPLICATION OR OTHER DESIGN ADVICE, WEB TOOLS, SAFETY INFORMATION, AND OTHER RESOURCES "AS IS" AND WITH ALL FAULTS, AND DISCLAIMS ALL WARRANTIES, EXPRESS AND IMPLIED, INCLUDING WITHOUT LIMITATION ANY IMPLIED WARRANTIES OF MERCHANTABILITY, FITNESS FOR A PARTICULAR PURPOSE OR NON-INFRINGEMENT OF THIRD PARTY INTELLECTUAL PROPERTY RIGHTS.

These resources are intended for skilled developers designing with TI products. You are solely responsible for (1) selecting the appropriate TI products for your application, (2) designing, validating and testing your application, and (3) ensuring your application meets applicable standards, and any other safety, security, regulatory or other requirements.

These resources are subject to change without notice. TI grants you permission to use these resources only for development of an application that uses the TI products described in the resource. Other reproduction and display of these resources is prohibited. No license is granted to any other TI intellectual property right or to any third party intellectual property right. TI disclaims responsibility for, and you will fully indemnify TI and its representatives against, any claims, damages, costs, losses, and liabilities arising out of your use of these resources.

TI's products are provided subject to [TI's Terms of Sale](#) or other applicable terms available either on [ti.com](https://www.ti.com) or provided in conjunction with such TI products. TI's provision of these resources does not expand or otherwise alter TI's applicable warranties or warranty disclaimers for TI products.

TI objects to and rejects any additional or different terms you may have proposed.

Mailing Address: Texas Instruments, Post Office Box 655303, Dallas, Texas 75265  
Copyright © 2023, Texas Instruments Incorporated

## Looking for pricing, stock, or lifecycle information?

Click below to explore more details on WIN SOURCE:

 [View SN74ALS323N on WIN SOURCE](#)

 [Texas Instruments](#) Information

## Optimize Your Supply Chain with WIN SOURCE Solutions

-  Global Sourcing Solution
-  Obsolete Management
-  Cost Control Management
-  Shortage Management
-  Alternative Solution
-  Excess Inventory Management