



THE DATASHEET OF LM2695SDX/NOPB



LM2695 High Voltage (30V, 1.25A) Step Down Switching Regulator

Check for Samples: [LM2695](#)

FEATURES

- Integrated 33V, N-Channel Buck Switch
- Integrated Start-Up Regulator
- Input Voltage Range: 8V to 30V
- No Loop Compensation Required
- Ultra-Fast Transient Response
- Operating Frequency Remains Constant with Load Current and Input Voltage
- Maximum Duty Cycle Limited During Start-Up
- Adjustable Output Voltage
- Valley Current Limit At 1.25A
- Precision Internal Reference
- Low Bias Current
- Highly Efficient Operation
- Thermal Shutdown

TYPICAL APPLICATIONS

- High Efficiency Point-Of-Load (POL) Regulator
- Non-Isolated Telecommunication Buck Regulator
- Secondary High Voltage Post Regulator

DESCRIPTION

The LM2695 Step Down Switching Regulator features all of the functions needed to implement a low cost, efficient, buck bias regulator capable of supplying 1.25A to the load. This buck regulator contains a 33V N-Channel Buck Switch, and is available in the thermally enhanced WSON-10 and HTSSOP-14 packages. The hysteretic regulation scheme requires no loop compensation, results in fast load transient response, and simplifies circuit implementation. The operating frequency remains constant with line and load variations due to the inverse relationship between the input voltage and the on-time. The current limit detection is set at 1.25A. Additional features include: VCC under-voltage lockout, thermal shutdown, gate drive under-voltage lockout, and maximum duty cycle limiter.

PACKAGE

- 10-Pin WSON (4 mm x 4 mm)
- 14-Pin HTSSOP
- Exposed Thermal Pad For Improved Heat Dissipation

Basic Step Down Regulator

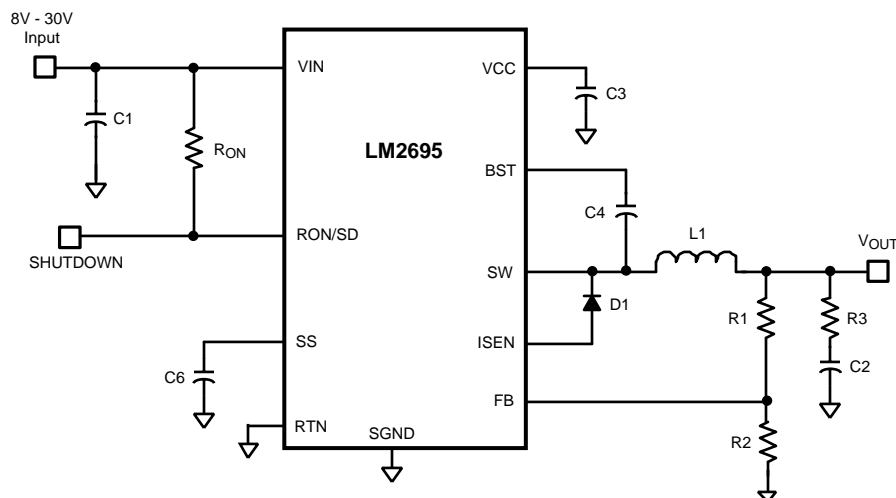

Please be aware that an important notice concerning availability, standard warranty, and use in critical applications of Texas Instruments semiconductor products and disclaimers thereto appears at the end of this data sheet.

All trademarks are the property of their respective owners.

Connection Diagram

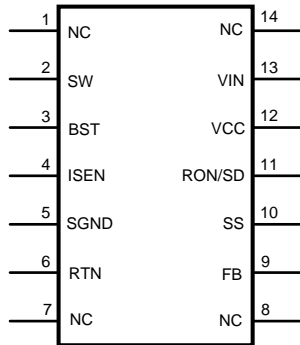

Figure 1. 14-Lead HTSSOP (Top View)
See PWP0014A Package

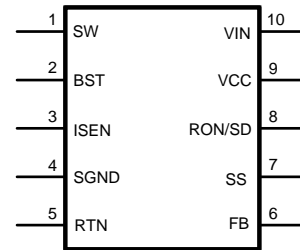

Figure 2. 10-Lead WSON (Top View)
See DPR0010A Package

PIN DESCRIPTIONS

Pin Number		Name	Description	Application Information
WSON-10	HTSSOP-14			
1	2	SW	Switching Node	Internally connected to the buck switch source. Connect to the inductor, free-wheeling diode, and bootstrap capacitor.
2	3	BST	Boost pin for bootstrap capacitor	Connect a 0.022 μ F capacitor from SW to this pin. The capacitor is charged from V_{CC} via an internal diode during each off-time.
3	4	I_{SEN}	Current sense	The re-circulating current flows through the internal sense resistor, and out of this pin to the free-wheeling diode. Current limit is nominally set at 1.25A.
4	5	S_{GND}	Sense Ground	Re-circulating current flows into this pin to the current sense resistor.
5	6	RTN	Circuit Ground	Ground for all internal circuitry other than the current limit detection.
6	9	FB	Feedback input from the regulated output	Internally connected to the regulation and over-voltage comparators. The regulation level is 2.5V.
7	10	SS	Softstart	An internal 12.3 μ A current source charges an external capacitor to 2.5V, providing the softstart function.
8	11	$R_{ON/SD}$	On-time control and shutdown	An external resistor from V_{IN} to this pin sets the buck switch on-time. Grounding this pin shuts down the regulator.
9	12	V_{CC}	Output from the startup regulator	Nominally regulates at 7.0V. An external voltage (8V-14V) can be applied to this pin to reduce internal dissipation. An internal diode connects V_{CC} to V_{IN} .
10	13	V_{IN}	Input supply voltage	Nominal input range is 8.0V to 30V.
	1,7,8,14	NC	No connection.	No internal connection.
		EP	Exposed Pad	Exposed metal pad on the underside of the device. It is recommended to connect this pad to the PC board ground plane to aid in heat dissipation.



These devices have limited built-in ESD protection. The leads should be shorted together or the device placed in conductive foam during storage or handling to prevent electrostatic damage to the MOS gates.

Absolute Maximum Ratings⁽¹⁾⁽²⁾⁽³⁾

VIN to RTN		33V
BST to RTN		47V
SW to RTN (Steady State)		-1.5V
ESD Rating ⁽⁴⁾	Human Body Model	2kV
BST to VCC		33V
VIN to SW		33V
BST to SW		14V
VCC to RTN		14V
SGND to RTN		-0.3V to +0.3V
Current out of ISEN		See Text
SS to RTN		-0.3V to 4V
All Other Inputs to RTN		-0.3 to 7V
Storage Temperature Range		-65°C to +150°C
Junction Temperature		150°C

- (1) Absolute Maximum Ratings are limits beyond which damage to the device may occur. Operating Ratings are conditions under which operation of the device is intended to be functional. For ensured specifications and test conditions, see the Electrical Characteristics.
- (2) For detailed information on soldering plastic WSON-10 packages, refer to the Packaging Data Book available from TI.
- (3) If Military/Aerospace specified devices are required, please contact the TI Sales Office/Distributors for availability and specifications.
- (4) The human body model is a 100pF capacitor discharged through a 1.5kΩ resistor into each pin.

Operating Ratings⁽¹⁾

VIN		8.0V to 30V
Junction Temperature		-40°C to +125°C

- (1) Absolute Maximum Ratings are limits beyond which damage to the device may occur. Operating Ratings are conditions under which operation of the device is intended to be functional. For ensured specifications and test conditions, see the Electrical Characteristics.

Electrical Characteristics

Specifications with standard type are for $T_J = 25^\circ\text{C}$ only; limits in **boldface** type apply over the full Operating Junction Temperature (T_J) range. Minimum and Maximum limits are ensured through test, design, or statistical correlation. Typical values represent the most likely parametric norm at $T_J = 25^\circ\text{C}$, and are provided for reference purposes only. Unless otherwise stated the following conditions apply: $V_{IN} = 24\text{V}$, $R_{ON} = 200\text{k}\Omega$ ⁽¹⁾.

Symbol	Parameter	Conditions	Min	Typ	Max	Units
Start-Up Regulator, V_{CC}						
V_{CCReg}	V_{CC} regulated output		6.6	7	7.4	V
	V_{IN} - V_{CC} dropout voltage	$I_{CC} = 0\text{ mA}$, $V_{CC} = UVLO_{VCC} + 250\text{ mV}$		1.3		V
	V_{CC} output impedance	$0\text{ mA} \leq I_{CC} \leq 5\text{ mA}$		140		Ω
	V_{CC} current limit ⁽²⁾	$V_{CC} = 0\text{V}$		9.7		mA
$UVLO_{VCC}$	V_{CC} under-voltage lockout threshold	V_{CC} increasing		5.7		V
	$UVLO_{VCC}$ hysteresis	V_{CC} decreasing		150		mV
	$UVLO_{VCC}$ filter delay	100 mV overdrive		3		μs
	I_{IN} operating current	Non-switching, $FB = 3\text{V}$		0.5	0.8	mA
	I_{IN} shutdown current	$R_{ON}/SD = 0\text{V}$		95	200	μA
Switch Characteristics						
$R_{ds(on)}$	Buck Switch $R_{ds(on)}$	$I_{TEST} = 200\text{ mA}$		0.33	0.7	Ω
$UVLO_{GD}$	Gate Drive UVLO	$V_{BST} - V_{SW}$ Increasing	3.0	4.4	5.5	V
	$UVLO_{GD}$ hysteresis			480		mV
Softstart Pin						
	Pull-up voltage			2.5		V
	Internal current source			12.3		μA
Current Limit						
I_{LIM}	Threshold	Current out of ISEN	1	1.25	1.5	A
	Resistance from ISEN to SGND			130		$\text{m}\Omega$
	Response time			150		ns
On Timer						
t_{ON-1}	On-time	$V_{IN} = 10\text{V}$, $R_{ON} = 200\text{ k}\Omega$	2.1	2.8	3.6	μs
t_{ON-2}	On-time	$V_{IN} = 30\text{V}$, $R_{ON} = 200\text{ k}\Omega$		950		ns
	Shutdown threshold	Voltage at R_{ON}/SD rising	0.45	0.8	1.2	V
	Threshold hysteresis	Voltage at R_{ON}/SD falling		37		mV
Off Timer						
t_{OFF}	Minimum Off-time			250		ns
Regulation and Over-Voltage Comparators (FB Pin)						
V_{REF}	FB regulation threshold	SS pin = steady state	2.440	2.5	2.550	V
	FB over-voltage threshold			2.9		V
	FB bias current			1		nA
Thermal Shutdown						
T_{SD}	Thermal shutdown temperature			175		$^\circ\text{C}$
	Thermal shutdown hysteresis			20		$^\circ\text{C}$
Thermal Resistance						
θ_{JA}	Junction to Ambient 0 LFPM Air Flow	Both Packages		37		$^\circ\text{C}/\text{W}$
θ_{JC}	Junction to Case	Both Packages		6.6		$^\circ\text{C}/\text{W}$

(1) Typical specifications represent the most likely parametric norm at 25°C operation.

(2) V_{CC} provides self bias for the internal gate drive and control circuits. Device thermal limitations limit external loading

Typical Performance Characteristics

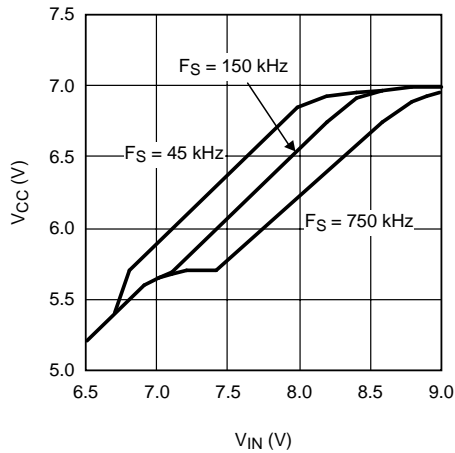

Figure 3. V_{CC} vs V_{IN}

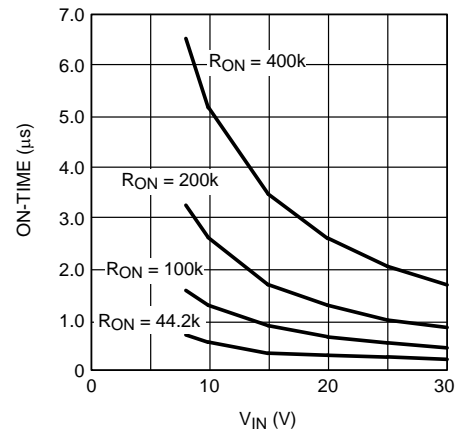
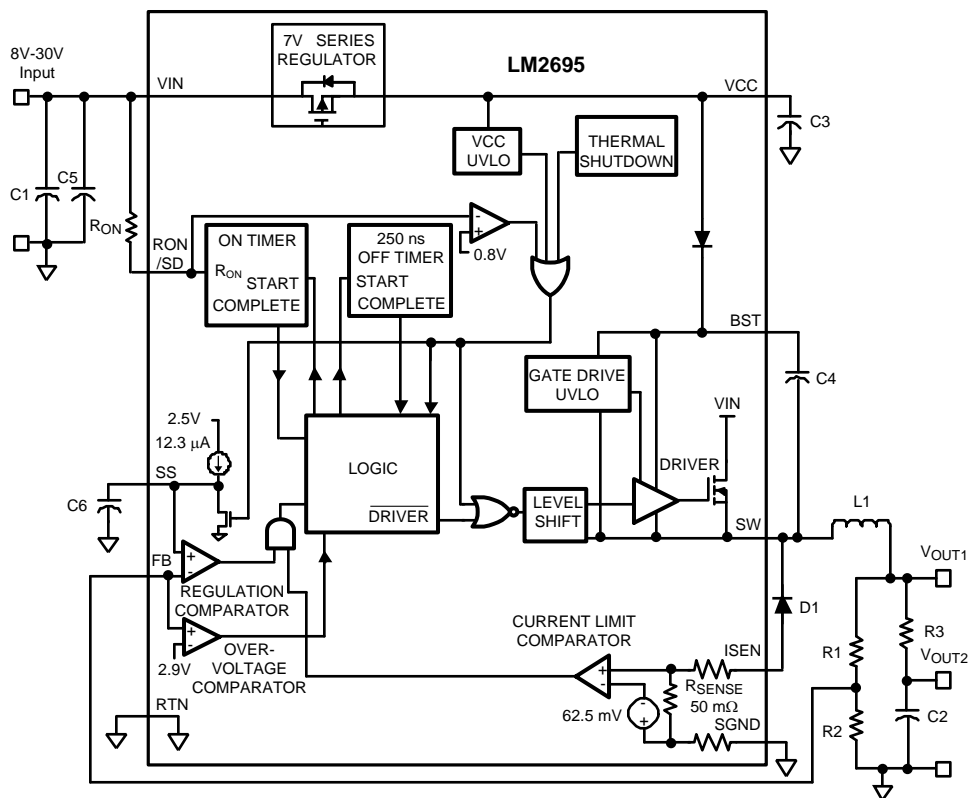

Figure 4. ON-Time vs V_{IN} and R_{ON}

Typical Application Circuit and Block Diagram



Functional Description

The LM2695 Step Down Switching Regulator features all the functions needed to implement a low cost, efficient buck bias power converter capable of supplying 1.25A to the load. This high voltage regulator contains a 33V N-Channel buck switch, is easy to implement, and is available in the thermally enhanced WSON-10 and HTSSOP-14 packages. The regulator's operation is based on a hysteretic control scheme, and uses an on-time control which varies inversely with V_{IN} . This feature allows the operating frequency to remain relatively constant with load and input voltage variations. The hysteretic control requires no loop compensation resulting in very fast load transient response. The valley current limit detection circuit, internally set at 1.25A, holds the buck switch off until the high current level subsides. The functional block diagram is shown in [Typical Application Circuit and Block Diagram](#).

The LM2695 can be applied in numerous applications to efficiently regulate down higher voltages. Additional features include: Thermal shutdown, V_{CC} under-voltage lockout, gate drive under-voltage lockout, and maximum duty cycle limiter.

Hysteretic Control Circuit Overview

The LM2695 buck DC-DC regulator employs a control scheme based on a comparator and a one-shot on-timer, with the output voltage feedback (FB) compared to an internal reference (2.5V). If the FB voltage is below the reference the buck switch is turned on for a time period determined by the input voltage and a programming resistor (R_{ON}). Following the on-time the switch remains off for a minimum of 250 ns, and until the FB voltage falls below the reference. The buck switch then turns on for another on-time period. Typically, during start-up, or when the load current increases suddenly, the off-times are at the minimum of 250 ns. Once regulation is established, the off-times are longer.

When in regulation, the LM2695 operates in continuous conduction mode at heavy load currents and discontinuous conduction mode at light load currents. In continuous conduction mode current always flows through the inductor, never reaching zero during the off-time. In this mode the operating frequency remains relatively constant with load and line variations. The minimum load current for continuous conduction mode is one-half the inductor's ripple current amplitude. The operating frequency is approximately:

$$F_s = \frac{V_{OUT}}{1.3 \times 10^{-10} \times R_{ON}} \quad (1)$$

The buck switch duty cycle is equal to:

$$DC = \frac{t_{ON}}{t_{ON} + t_{OFF}} = \frac{V_{OUT}}{V_{IN}} \quad (2)$$

In discontinuous conduction mode current through the inductor ramps up from zero to a peak during the on-time, then ramps back to zero before the end of the off-time. The next on-time period starts when the voltage at FB falls below the reference - until then the inductor current remains zero, and the load current is supplied by the output capacitor (C2). In this mode the operating frequency is lower than in continuous conduction mode, and varies with load current. Conversion efficiency is maintained at light loads since the switching losses reduce with the reduction in load and frequency. The approximate discontinuous operating frequency can be calculated as follows:

$$F_s = \frac{V_{OUT}^2 \times L_1 \times 1.18 \times 10^{20}}{R_L \times (R_{ON})^2}$$

where

- R_L = the load resistance (3)

The output voltage is set by two external resistors (R_1 , R_2). The regulated output voltage is calculated as follows:

$$V_{OUT} = 2.5 \times (R_1 + R_2) / R_2 \quad (4)$$

Output voltage regulation is based on ripple voltage at the feedback input, requiring a minimum amount of ESR for the output capacitor C2. The LM2695 requires a minimum of 25 mV of ripple voltage at the FB pin. In cases where the capacitor's ESR is insufficient additional series resistance may be required (R3 in [Typical Application Circuit and Block Diagram](#)).

For applications where lower output voltage ripple is required the output can be taken directly from a low ESR output capacitor as shown in [Figure 5](#). However, R3 slightly degrades the load regulation.

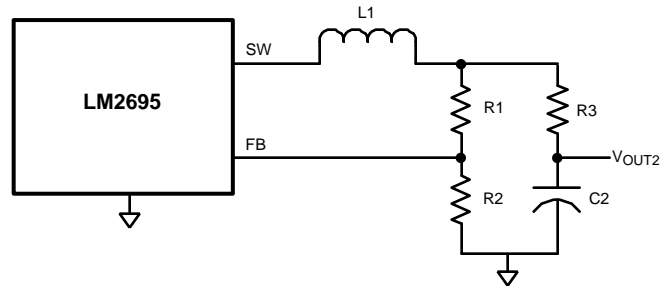

Figure 5. Low Ripple Output Configuration

Start-Up Regulator, V_{CC}

The start-up regulator is integral to the LM2695. The input pin (V_{IN}) can be connected directly to line voltage up to 30V, with transient capability to 33V. The V_{CC} output regulates at 7.0V, and is current limited at 9.7 mA. Upon power up, the regulator sources current into the external capacitor at V_{CC} (C3). When the voltage on the V_{CC} pin reaches the under-voltage lockout threshold of 5.7V, the buck switch is enabled and the Softstart pin is released to allow the Softstart capacitor (C6) to charge up.

The minimum input voltage is determined by the regulator's dropout voltage, the V_{CC} UVLO falling threshold ($\approx 5.5V$), and the frequency. When V_{CC} falls below the falling threshold the V_{CC} UVLO activates to shut off the output. If V_{CC} is externally loaded, the minimum input voltage increases since the output impedance at V_{CC} is $\approx 140\Omega$.

To reduce power dissipation in the start-up regulator, an auxiliary voltage can be diode connected to the V_{CC} pin. Setting the auxiliary voltage to between 8V and 14V shuts off the internal regulator, reducing internal power dissipation. The sum of the auxiliary voltage and the input voltage ($V_{CC} + V_{IN}$) cannot exceed 47V. Internally, a diode connects V_{CC} to V_{IN} . See [Figure 6](#).

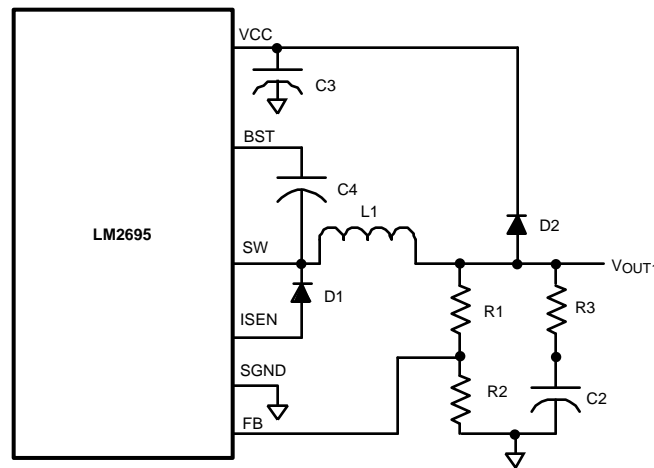

Figure 6. Self Biased Configuration

Regulation Comparator

The feedback voltage at FB is compared to the voltage at the Softstart pin (2.5V). In normal operation (the output voltage is regulated), an on-time period is initiated when the voltage at FB falls below 2.5V. The buck switch stays on for the programmed on-time, causing the FB voltage to rise above 2.5V. After the on-time period, the buck switch stays off until the FB voltage falls below 2.5V. Input bias current at the FB pin is less than 100 nA over temperature.

Over-Voltage Comparator

The voltage at FB is compared to an internal 2.9V reference. If the voltage at FB rises above 2.9V the on-time pulse is immediately terminated. This condition can occur if the input voltage or the output load changes suddenly, or if the inductor (L1) saturates. The buck switch remains off until the voltage at FB falls below 2.5V.

ON-Time Timer, and Shutdown

The on-time for the LM2695 is determined by the R_{ON} resistor and the input voltage (V_{IN}), and is calculated from:

$$t_{ON} = \frac{1.3 \times 10^{-10} \times R_{ON}}{V_{IN}} \quad (5)$$

See [Figure 4](#). The inverse relationship with V_{IN} results in a nearly constant frequency as V_{IN} is varied. To set a specific continuous conduction mode switching frequency (FS), the R_{ON} resistor is determined from the following:

$$R_{ON} = \frac{V_{OUT}}{F_S \times 1.3 \times 10^{-10}} \quad (6)$$

In high frequency applications the minimum value for t_{ON} is limited by the maximum duty cycle required for regulation and the minimum off-time of (250 ns, $\pm 15\%$). The minimum off-time limits the maximum duty cycle achievable with a low voltage at V_{IN} . The minimum allowed on-time to regulate the desired V_{OUT} at the minimum V_{IN} is determined from the following:

$$t_{ON(min)} = \frac{V_{OUT} \times 288 \text{ ns}}{(V_{IN(min)} - V_{OUT})} \quad (7)$$

The LM2695 can be remotely shut down by taking the R_{ON}/SD pin below 0.8V. See [Figure 7](#). In this mode the SS pin is internally grounded, the on-timer is disabled, and bias currents are reduced. Releasing the R_{ON}/SD pin allows normal operation to resume. The voltage at the R_{ON}/SD pin is between 1.5V and 3.0V, depending on V_{IN} and the R_{ON} resistor.

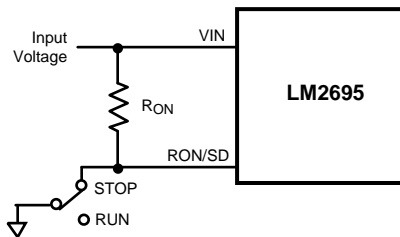

Figure 7. Shutdown Implementation

Current Limit

Current limit detection occurs during the off-time by monitoring the recirculating current through the free-wheeling diode (D1). Referring to [Typical Application Circuit and Block Diagram](#), when the buck switch is turned off the inductor current flows through the load, into SGND, through the sense resistor, out of ISEN and through D1. If that current exceeds 1.25A the current limit comparator output switches to delay the start of the next on-time period if the voltage at FB is below 2.5V. The next on-time starts when the current out of ISEN is below 1.25A and the voltage at FB is below 2.5V. If the overload condition persists causing the inductor current to exceed 1.25A during each on-time, that is detected at the beginning of each off-time. The operating frequency is lower due to longer-than-normal off-times.

[Figure 8](#) illustrates the inductor current waveform. During normal operation the load current is I_o , the average of the ripple waveform. When the load resistance decreases the current ratchets up until the lower peak reaches 1.25A. During the Current Limited portion of [Figure 8](#), the current ramps down to 1.25A during each off-time, initiating the next on-time (assuming the voltage at FB is $< 2.5V$). During each on-time the current ramps up an amount equal to:

$$\Delta I = (V_{IN} - V_{OUT}) \times t_{ON} / L1 \quad (8)$$

During this time the LM2695 is in a constant current mode, with an average load current (I_{OCL}) equal to $1.25A + \Delta I/2$.

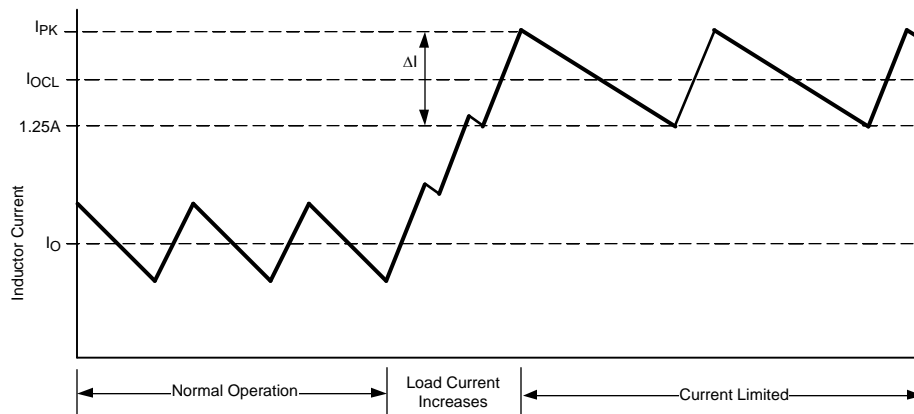

Figure 8. Inductor Current - Current Limit Operation

The current limit threshold can be increased by connecting an external resistor between SGND and ISEN. The external resistor will typically be less than 1Ω. The peak current out of SW and ISEN must not exceed 2A. The average current out of SW must be less than 1.5A.

N - Channel Buck Switch and Driver

The LM2695 integrates an N-Channel buck switch and associated floating high voltage gate driver. The peak current allowed through the buck switch is 2A, and the maximum allowed average current is 1.5A. The gate driver circuit works in conjunction with an external bootstrap capacitor and an internal high voltage diode. A 0.022 μF capacitor (C4) connected between BST and SW provides the voltage to the driver during the on-time. During each off-time, the SW pin is at approximately -1V, and C4 charges from V_{CC} through the internal diode. The minimum off-time of 250 ns ensures a minimum time each cycle to recharge the bootstrap capacitor.

Softstart

The softstart feature allows the converter to gradually reach a steady state operating point, thereby reducing start-up stresses and current surges. Upon turn-on, after V_{CC} reaches the under-voltage threshold, an internal 12.3 μA current source charges up the external capacitor at the SS pin to 2.5V. The ramping voltage at SS (and the non-inverting input of the regulation comparator) ramps up the output voltage in a controlled manner.

An internal switch grounds the SS pin if V_{CC} is below the under-voltage lockout threshold, if a thermal shutdown occurs, or if the RON/SD pin is grounded.

Thermal Shutdown

The LM2695 should be operated so the junction temperature does not exceed 125°C. If the junction temperature increases, an internal Thermal Shutdown circuit, which activates (typically) at 175°C, takes the controller to a low power reset state by disabling the buck switch and the on-timer, and grounding the Softstart pin. This feature helps prevent catastrophic failures from accidental device overheating. When the junction temperature reduces below 155°C (typical hysteresis = 20°C), the Softstart pin is released and normal operation resumes.

APPLICATIONS INFORMATION

EXTERNAL COMPONENTS

The following guidelines can be used to select the external components.

R1 and R2: The ratio of these resistors is calculated from:

$$R1/R2 = (V_{OUT}/2.5V) - 1 \quad (9)$$

R1 and R2 should be chosen from standard value resistors in the range of 1.0 kΩ - 10 kΩ which satisfy the above ratio.

R_{ON}: The minimum value for R_{ON} is calculated from:

$$R_{ON} \geq \frac{200 \text{ ns} \times V_{IN(MAX)}}{1.3 \times 10^{-10}} \quad (10)$$

[Equation 1](#) can be used to select R_{ON} if a specific frequency is desired as long as the above limitation is met.

L1: The main parameter affected by the inductor is the output current ripple amplitude (I_{OR}). The limits for I_{OR} must be determined at both the minimum and maximum nominal load currents.

a) If the maximum load current is less than the current limit threshold (1.25A), the minimum load current is used to determine the maximum allowable ripple. To maintain continuous conduction mode the lower peak should not reach 0 mA. For this case, the maximum ripple current is:

$$I_{OR(MAX1)} = 2 \times I_{O(min)} \quad (11)$$

The ripple calculated in [Equation 11](#) is then used in the following equation:

$$L1 = \frac{V_{OUT} \times (V_{IN} - V_{OUT})}{I_{OR} \times F_S \times V_{IN}}$$

where

- V_{IN} is the maximum input voltage
 - F_s is determined from [Equation 1](#)
- (12)

This provides a minimum value for L1. The next larger standard value should be used, and L1 should be rated for the I_{PK} current level.

b) If the maximum load current is greater than the current limit threshold (1.25A), the LM2695 ensures the lower peak reaches 1.25A each cycle, requiring that I_{OR} be at least twice the difference. The upper peak, however, must not exceed 2A. For this case, the ripple limits are:

$$I_{OR(MAX2)} = 2 \times (2A - I_{O(max)}) \quad (13)$$

and

$$I_{OR(MIN1)} = 2 \times (I_{O(max)} - 1.25A) \quad (14)$$

The lesser of [Equation 13](#) and [Equation 14](#) is then used in [Equation 12](#). If I_{OR(MAX2)} is used, the maximum V_{IN} is used in [Equation 12](#). The next larger value should then be used for L1. If I_{OR(MIN1)} is used, the minimum V_{IN} is used in [Equation 12](#). The next smaller value should then be used for L1. L1 must be rated for the peak value of the current waveform (I_{PK} in [Figure 8](#)).

C3: The capacitor at the V_{CC} output provides not only noise filtering and stability, but also prevents false triggering of the V_{CC} UVLO at the buck switch on/off transitions. For this reason, C3 should be no smaller than 0.1 μF, and should be a good quality, low ESR, ceramic capacitor.

C2, and R3: Since the LM2695 requires a minimum of 25 mV_{p-p} of ripple at the FB pin for proper operation, the required ripple at V_{OUT1} is increased by R1 and R2. This necessary ripple is created by the inductor ripple current acting on C2's ESR + R3. The minimum ripple current is calculated using [Equation 12](#), rearranged to solve for I_{OR} at minimum V_{IN}. The minimum ESR for C2 is then equal to:

$$ESR_{(min)} = \frac{25 \text{ mV} \times (R1 + R2)}{R2 \times I_{OR(min)}} \quad (15)$$

If the capacitor used for C2 does not have sufficient ESR, R3 is added in series as shown in [Typical Application Circuit and Block Diagram](#). Generally R3 is less than 1Ω. C2 should generally be no smaller than 3.3 μF, although that is dependent on the frequency and the allowable ripple amplitude at V_{OUT1}. Experimentation is usually necessary to determine the minimum value for C2, as the nature of the load may require a larger value. A load which creates significant transients requires a larger value for C2 than a non-varying load.

D1: The important parameters are reverse recovery time and forward voltage. The reverse recovery time determines how long the reverse current surge lasts each time the buck switch is turned on. The forward voltage drop is significant in the event the output is short-circuited as it is mainly this diode's voltage (plus the voltage across the current limit sense resistor) which forces the inductor current to decrease during the off-time. For this reason, a higher voltage is better, although that affects efficiency. A reverse recovery time of ≈30 ns, and a forward voltage drop of ≈0.75V are preferred. The reverse leakage specification is important as that can significantly affect efficiency. D1's reverse voltage rating must be at least as great as the maximum V_{IN}, and its current rating must equal or exceed I_{PK} [Figure 8](#).

C1 and C5: C1's purpose is to supply most of the switch current during the on-time, and limit the voltage ripple at V_{IN}, on the assumption that the voltage source feeding V_{IN} has an output impedance greater than zero. If the source's dynamic impedance is high (effectively a current source), it supplies the average input current, but not the ripple current.

At maximum load current, when the buck switch turns on, the current into V_{IN} suddenly increases to the lower peak of the inductor's ripple current, ramps up to the peak value, then drop to zero at turn-off. The average current during the on-time is the load current. For a worst case calculation, C1 must supply this average load current during the maximum on-time. C1 is calculated from:

$$C1 = \frac{I_o \times t_{ON}}{\Delta V}$$

where

- I_o is the load current
- t_{ON} is the maximum on-time
- ΔV is the allowable ripple voltage at V_{IN} (16)

C5's purpose is to help avoid transients and ringing due to long lead inductance at V_{IN}. A low ESR, 0.1 μF ceramic chip capacitor is recommended, located close to the LM2695.

C4: The recommended value for C4 is 0.022 μF. A high quality ceramic capacitor with low ESR is recommended as C4 supplies a surge current to charge the buck switch gate at turn-on. A low ESR also helps ensure a complete recharge during each off-time.

C6: The capacitor at the SS pin determines the softstart time, i.e. the time for the reference voltage at the regulation comparator, and the output voltage, to reach their final value. The time is determined from the following:

$$t_{SS} = \frac{C6 \times 2.5V}{12.3 \mu A} \quad (17)$$

PC BOARD LAYOUT

The LM2695 regulation, over-voltage, and current limit comparators are very fast, and respond to short duration noise pulses. Layout considerations are therefore critical for optimum performance. The layout must be as neat and compact as possible, and all of the components must be as close as possible to their associated pins. The current loop formed by D1, L1, C2 and the SGND and ISEN pins should be as small as possible. The ground connection from C2 to C1 should be as short and direct as possible.

If it is expected that the internal dissipation of the LM2695 will produce excessive junction temperatures during normal operation, good use of the PC board's ground plane can help considerably to dissipate heat. The exposed pad on the bottom of the IC package can be soldered to a ground plane, and that plane should extend out from beneath the IC, and be connected to ground plane on the board's other side with several vias, to help dissipate the heat. The exposed pad is internally connected to the IC substrate. Additionally the use of wide PC board traces, where possible, can help conduct heat away from the IC. Judicious positioning of the PC board within the end product, along with the use of any available air flow (forced or natural convection) can help reduce the junction temperatures.

REVISION HISTORY

Changes from Original (April 2013) to Revision A	Page
• Changed layout of National Data Sheet to TI format	13

PACKAGING INFORMATION

Orderable Device	Status (1)	Package Type	Package Drawing	Pins	Package Qty	Eco Plan (2)	Lead finish/ Ball material (6)	MSL Peak Temp (3)	Op Temp (°C)	Device Marking (4/5)	Samples
LM2695MH/NOPB	ACTIVE	HTSSOP	PWP	14	94	RoHS & Green	SN	Level-1-260C-UNLIM	-40 to 125	L2695 MH	Samples
LM2695SDX/NOPB	ACTIVE	WSON	DPR	10	4500	RoHS & Green	SN	Level-1-260C-UNLIM	-40 to 125	L2695SD	Samples

(1) The marketing status values are defined as follows:

ACTIVE: Product device recommended for new designs.

LIFEBUY: TI has announced that the device will be discontinued, and a lifetime-buy period is in effect.

NRND: Not recommended for new designs. Device is in production to support existing customers, but TI does not recommend using this part in a new design.

PREVIEW: Device has been announced but is not in production. Samples may or may not be available.

OBSELETE: TI has discontinued the production of the device.

(2) **RoHS:** TI defines "RoHS" to mean semiconductor products that are compliant with the current EU RoHS requirements for all 10 RoHS substances, including the requirement that RoHS substance do not exceed 0.1% by weight in homogeneous materials. Where designed to be soldered at high temperatures, "RoHS" products are suitable for use in specified lead-free processes. TI may reference these types of products as "Pb-Free".

RoHS Exempt: TI defines "RoHS Exempt" to mean products that contain lead but are compliant with EU RoHS pursuant to a specific EU RoHS exemption.

Green: TI defines "Green" to mean the content of Chlorine (Cl) and Bromine (Br) based flame retardants meet JS709B low halogen requirements of <=1000ppm threshold. Antimony trioxide based flame retardants must also meet the <=1000ppm threshold requirement.

(3) **MSL, Peak Temp.** - The Moisture Sensitivity Level rating according to the JEDEC industry standard classifications, and peak solder temperature.

(4) There may be additional marking, which relates to the logo, the lot trace code information, or the environmental category on the device.

(5) Multiple Device Markings will be inside parentheses. Only one Device Marking contained in parentheses and separated by a "-" will appear on a device. If a line is indented then it is a continuation of the previous line and the two combined represent the entire Device Marking for that device.

(6) **Lead finish/Ball material** - Orderable Devices may have multiple material finish options. Finish options are separated by a vertical ruled line. Lead finish/Ball material values may wrap to two lines if the finish value exceeds the maximum column width.

Important Information and Disclaimer:The information provided on this page represents TI's knowledge and belief as of the date that it is provided. TI bases its knowledge and belief on information provided by third parties, and makes no representation or warranty as to the accuracy of such information. Efforts are underway to better integrate information from third parties. TI has taken and continues to take reasonable steps to provide representative and accurate information but may not have conducted destructive testing or chemical analysis on incoming materials and chemicals. TI and TI suppliers consider certain information to be proprietary, and thus CAS numbers and other limited information may not be available for release.

In no event shall TI's liability arising out of such information exceed the total purchase price of the TI part(s) at issue in this document sold by TI to Customer on an annual basis.

TAPE AND REEL INFORMATION

QUADRANT ASSIGNMENTS FOR PIN 1 ORIENTATION IN TAPE



*All dimensions are nominal

Device	Package Type	Package Drawing	Pins	SPQ	Reel Diameter (mm)	Reel Width W1 (mm)	A0 (mm)	B0 (mm)	K0 (mm)	P1 (mm)	W (mm)	Pin1 Quadrant
LM2695SDX/NOPB	WSO	DPR	10	4500	330.0	12.4	4.3	4.3	1.3	8.0	12.0	Q1

TAPE AND REEL BOX DIMENSIONS

*All dimensions are nominal

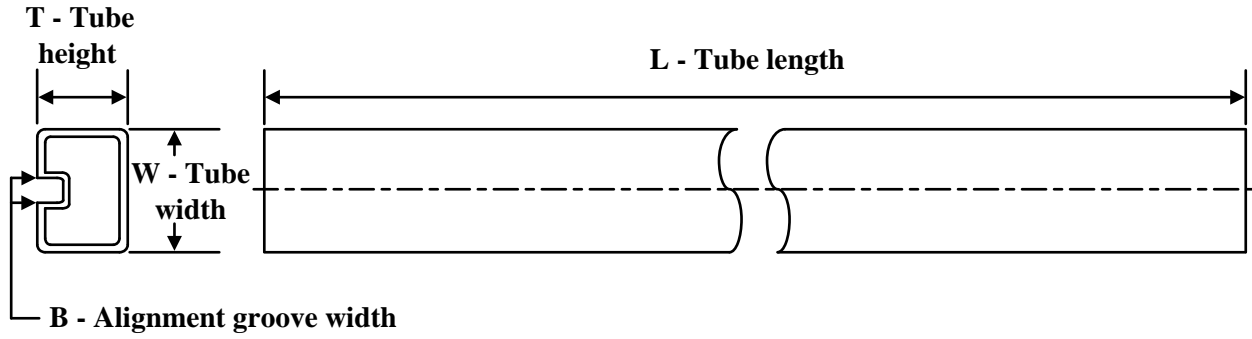
Device	Package Type	Package Drawing	Pins	SPQ	Length (mm)	Width (mm)	Height (mm)
LM2695SDX/NOPB	WSON	DPR	10	4500	367.0	367.0	35.0

TUBE

*All dimensions are nominal

Device	Package Name	Package Type	Pins	SPQ	L (mm)	W (mm)	T (μm)	B (mm)
LM2695MH/NOPB	PWP	HTSSOP	14	94	495	8	2514.6	4.06

EXAMPLE BOARD LAYOUT

DPR0010A

WSON - 0.8 mm max height

PLASTIC SMALL OUTLINE - NO LEAD

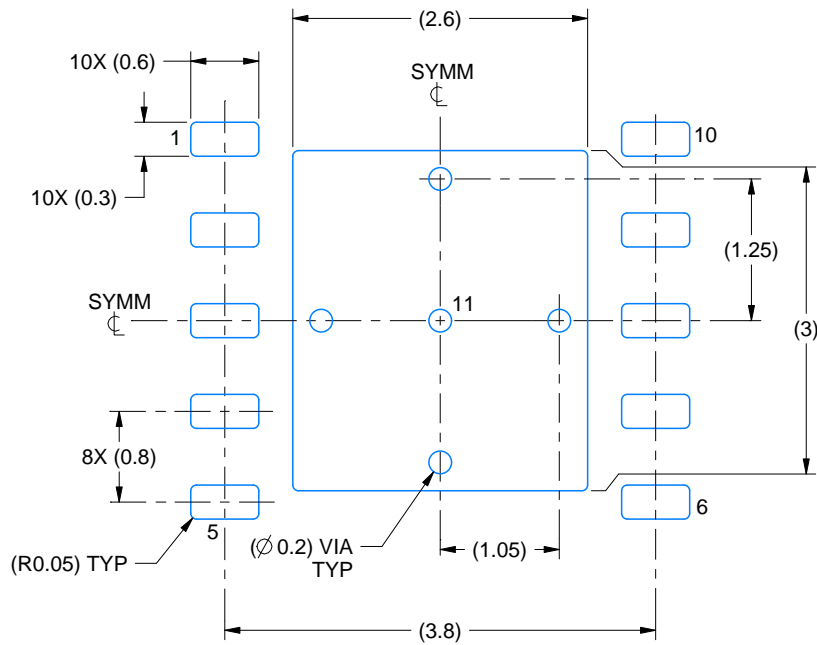

LAND PATTERN EXAMPLE
EXPOSED METAL SHOWN
SCALE:15X

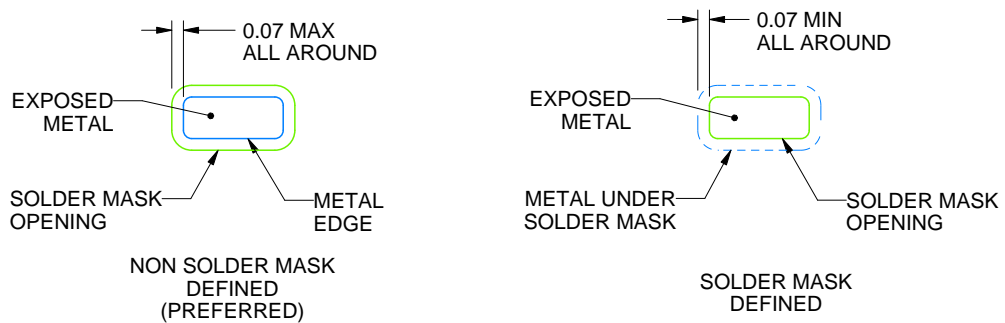

SOLDER MASK DETAILS

4218856/B 01/2021

NOTES: (continued)

4. This package is designed to be soldered to a thermal pad on the board. For more information, see Texas Instruments literature number SLUA271 (www.ti.com/lit/slua271).

EXAMPLE STENCIL DESIGN

DPR0010A

WSON - 0.8 mm max height

PLASTIC SMALL OUTLINE - NO LEAD

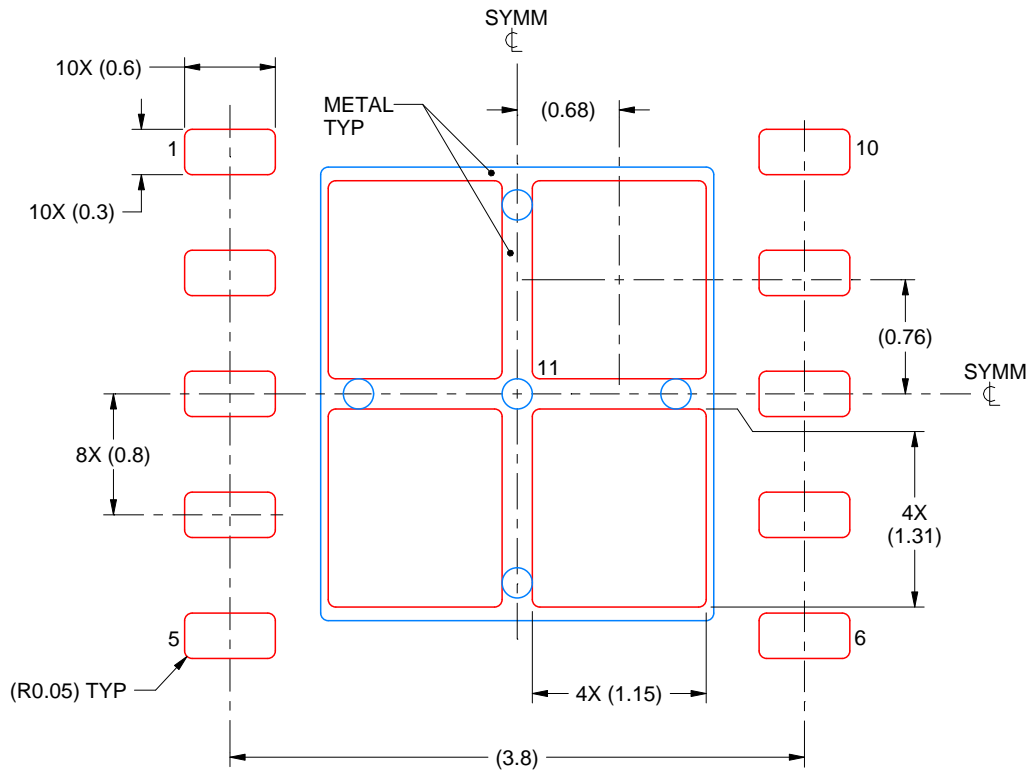

SOLDER PASTE EXAMPLE
BASED ON 0.125 mm THICK STENCIL

EXPOSED PAD 11:
77% PRINTED SOLDER COVERAGE BY AREA
SCALE:20X

4218856/B 01/2021

NOTES: (continued)

5. Laser cutting apertures with trapezoidal walls and rounded corners may offer better paste release. IPC-7525 may have alternate design recommendations.

EXAMPLE BOARD LAYOUT

PWP0014A

PowerPAD™ TSSOP - 1.2 mm max height

PLASTIC SMALL OUTLINE

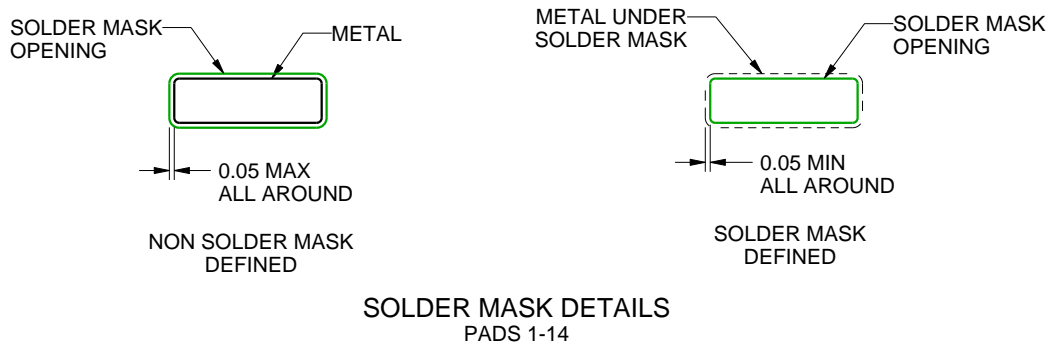
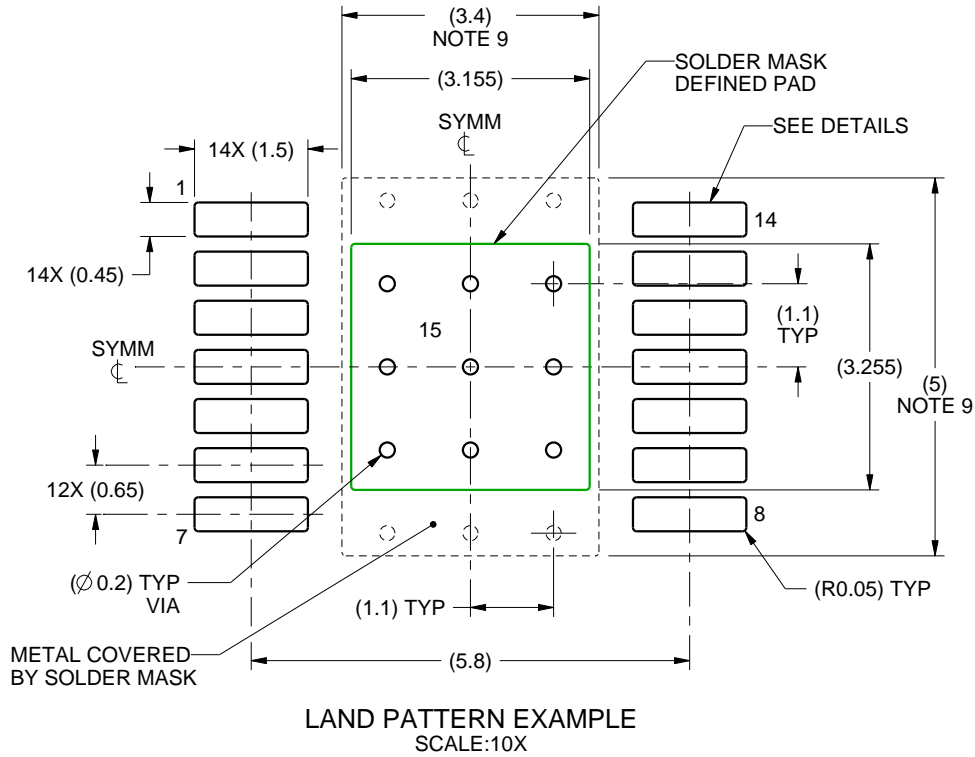

4214867/A 09/2016

NOTES: (continued)

6. Publication IPC-7351 may have alternate designs.
7. Solder mask tolerances between and around signal pads can vary based on board fabrication site.
8. This package is designed to be soldered to a thermal pad on the board. For more information, see Texas Instruments literature numbers SLMA002 (www.ti.com/lit/slma002) and SLMA004 (www.ti.com/lit/slma004).
9. Size of metal pad may vary due to creepage requirement.

IMPORTANT NOTICE AND DISCLAIMER

TI PROVIDES TECHNICAL AND RELIABILITY DATA (INCLUDING DATA SHEETS), DESIGN RESOURCES (INCLUDING REFERENCE DESIGNS), APPLICATION OR OTHER DESIGN ADVICE, WEB TOOLS, SAFETY INFORMATION, AND OTHER RESOURCES "AS IS" AND WITH ALL FAULTS, AND DISCLAIMS ALL WARRANTIES, EXPRESS AND IMPLIED, INCLUDING WITHOUT LIMITATION ANY IMPLIED WARRANTIES OF MERCHANTABILITY, FITNESS FOR A PARTICULAR PURPOSE OR NON-INFRINGEMENT OF THIRD PARTY INTELLECTUAL PROPERTY RIGHTS.

These resources are intended for skilled developers designing with TI products. You are solely responsible for (1) selecting the appropriate TI products for your application, (2) designing, validating and testing your application, and (3) ensuring your application meets applicable standards, and any other safety, security, regulatory or other requirements.

These resources are subject to change without notice. TI grants you permission to use these resources only for development of an application that uses the TI products described in the resource. Other reproduction and display of these resources is prohibited. No license is granted to any other TI intellectual property right or to any third party intellectual property right. TI disclaims responsibility for, and you will fully indemnify TI and its representatives against, any claims, damages, costs, losses, and liabilities arising out of your use of these resources.



TI's products are provided subject to [TI's Terms of Sale](#) or other applicable terms available either on ti.com or provided in conjunction with such TI products. TI's provision of these resources does not expand or otherwise alter TI's applicable warranties or warranty disclaimers for TI products.

TI objects to and rejects any additional or different terms you may have proposed.

Mailing Address: Texas Instruments, Post Office Box 655303, Dallas, Texas 75265
Copyright © 2022, Texas Instruments Incorporated

Looking for pricing, stock, or lifecycle information?

Click below to explore more details on WIN SOURCE:

-  [View LM2695SDX/NOPB on WIN SOURCE](#)
-  [Texas Instruments](#) Information

Optimize Your Supply Chain with WIN SOURCE Solutions

-  Global Sourcing Solution
-  Obsolete Management
-  Cost Control Management
-  Shortage Management
-  Alternative Solution
-  Excess Inventory Management