



**THE DATASHEET OF  
SN74LV594APWTG4**



# SN74LV594A 8-Bit Shift Registers With Output Registers

## 1 Features

- $V_{CC}$  operation of 2 V to 5.5 V
- Maximum  $t_{pd}$  of 6.5 ns at 5 V
- Typical  $V_{OLP}$  (output ground bounce)  $<0.8$  V at  $V_{CC} = 3.3$  V,  $T_A = 25^\circ\text{C}$
- Support mixed-mode voltage operation on all ports
- 8-bit serial-in, parallel-out shift registers with storage
- Independent direct overriding clears on shift and storage registers
- Independent clocks for shift and storage registers
- Latch-up performance exceeds 100 mA per JESD 78, Class II

## 2 Applications

- ECG electrocardiograms
- Storage servers
- EPOS, ECR, and cash drawers
- Servers and high-performance computing

## 3 Description

The SN74LV594A devices are 8-bit shift registers designed for 2 V to 5.5 V  $V_{CC}$  operation.

### Package Information<sup>(1)</sup>

PART NUMBER	PACKAGE	BODY SIZE (NOM)
SN74LV594A	DB (SSOP, 16)	6.20 mm × 5.30 mm
	D (SOIC, 16)	9.90 mm × 3.91 mm
	PW (TSSOP, 16)	5.00 mm × 4.40 mm
	BQB (WQFN, 16)	3.60 mm × 2.60 mm

(1) For all available packages, see the orderable addendum at the end of the data sheet.

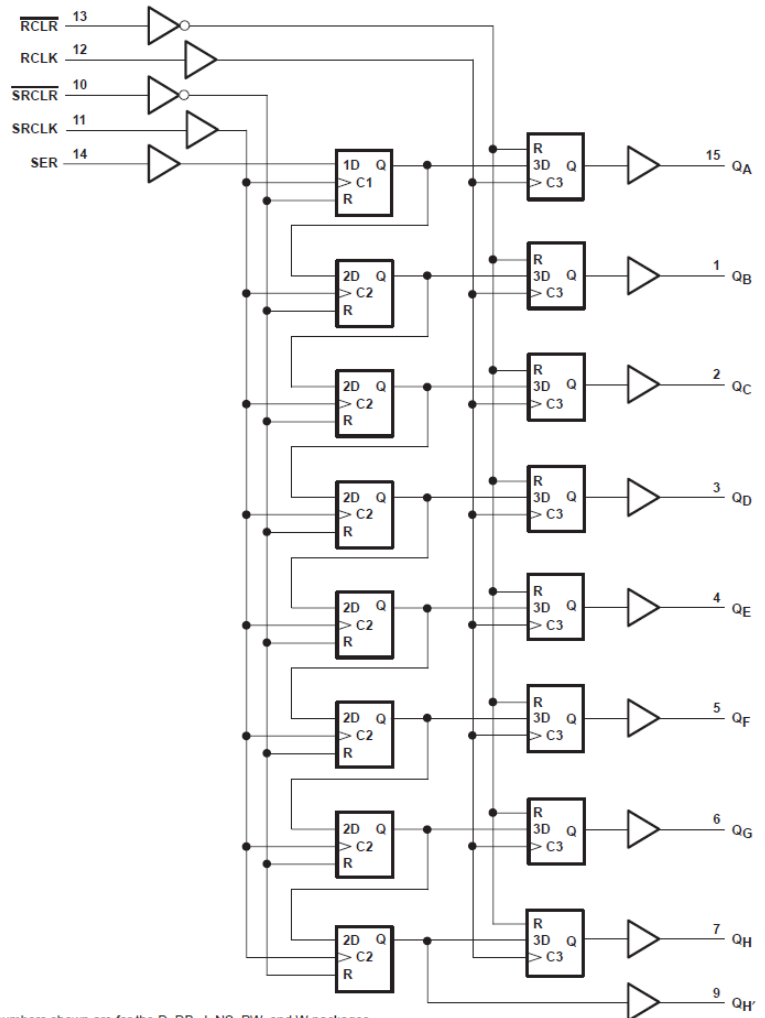

Pin numbers shown are for the D, DB, J, NS, PW, and W packages.

Logic Diagram (Positive Logic)



## Table of Contents

<b>1 Features</b> .....	<b>1</b>	<b>7 Parameter Measurement Information</b> .....	<b>11</b>
<b>2 Applications</b> .....	<b>1</b>	<b>8 Detailed Description</b> .....	<b>12</b>
<b>3 Description</b> .....	<b>1</b>	8.1 Overview.....	12
<b>4 Revision History</b> .....	<b>2</b>	8.2 Functional Block Diagram.....	13
<b>5 Pin Configuration and Functions</b> .....	<b>3</b>	8.3 Feature Description.....	14
<b>6 Specifications</b> .....	<b>4</b>	8.4 Device Functional Modes.....	14
6.1 Absolute Maximum Ratings.....	4	<b>9 Application and Implementation</b> .....	<b>15</b>
6.2 ESD Ratings.....	4	9.1 Application Information.....	15
6.3 Recommended Operating Conditions.....	5	9.2 Typical Application.....	15
6.4 Thermal Information.....	5	9.3 Power Supply Recommendations.....	16
6.5 Electrical Characteristics.....	6	9.4 Layout.....	16
6.6 Switching Characteristics: $V_{CC} = 2.5\text{ V} \pm 0.2\text{ V}$ .....	6	<b>10 Device and Documentation Support</b> .....	<b>18</b>
6.7 Switching Characteristics: $V_{CC} = 3.3\text{ V} \pm 0.3\text{ V}$ .....	7	10.1 Receiving Notification of Documentation Updates..	18
6.8 Switching Characteristics: $V_{CC} = 5\text{ V} \pm 0.5\text{ V}$ .....	7	10.2 Support Resources.....	18
6.9 Timing Requirements: $V_{CC} = 2.5\text{ V} \pm 0.2\text{ V}$ .....	8	10.3 Trademarks.....	18
6.10 Timing Requirements: $V_{CC} = 3.3\text{ V} \pm 0.3\text{ V}$ .....	8	10.4 Electrostatic Discharge Caution.....	18
6.11 Timing Requirements: $V_{CC} = 5\text{ V} \pm 0.5\text{ V}$ .....	9	10.5 Glossary.....	18
6.12 Noise Characteristics.....	9	<b>11 Mechanical, Packaging, and Orderable Information</b> .....	<b>18</b>
6.13 Operating Characteristics.....	9		
6.14 Typical Characteristics.....	10		

## 4 Revision History

NOTE: Page numbers for previous revisions may differ from page numbers in the current version.

<b>Changes from Revision J (February 2015) to Revision K (December 2022)</b>	<b>Page</b>
• Added BQB package information to Pin Configuration and Functions and Thermal Information. Updated the format of tables, figures, and cross-references throughout the document. ....	<b>1</b>

---

<b>Changes from Revision I (April 2005) to Revision J (February 2015)</b>	<b>Page</b>
• Added <i>Pin Configuration and Functions</i> section, <i>ESD Ratings</i> table, <i>Feature Description</i> section, <i>Device Functional Modes</i> , <i>Application and Implementation</i> section, <i>Power Supply Recommendations</i> section, <i>Layout</i> section, <i>Device and Documentation Support</i> section, and <i>Mechanical, Packaging, and Orderable Information</i> section .....	<b>1</b>

## 5 Pin Configuration and Functions

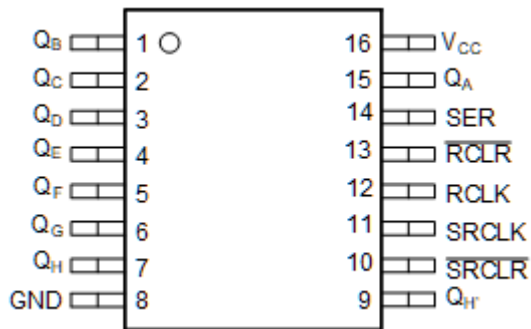

Figure 5-1. D, DB, or PW Package 16-Pin SOIC, SSOP, or TSSOP Top View

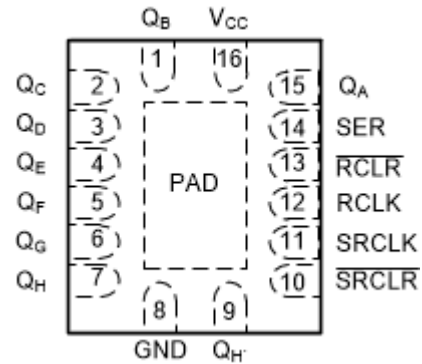

Figure 5-2. BQB Package 16-Pin WQFN Top View

Table 5-1. Pin Functions

PIN		TYPE <sup>(1)</sup>	DESCRIPTION
NAME	NO.		
Q <sub>B</sub>	1	O	Output B
Q <sub>C</sub>	2	O	Output C
Q <sub>D</sub>	3	O	Output D
Q <sub>E</sub>	4	O	Output E
Q <sub>F</sub>	5	O	Output F
Q <sub>G</sub>	6	O	Output G
Q <sub>H</sub>	7	O	Output H
GND	8	G	Ground pin
Q <sub>H'</sub>	9	O	Q <sub>H</sub> inverted
SRCLR	10	I	Serial clear
SRCLK	11	I	Serial clock
RCLK	12	I	Storage clock
RCLR	13	I	Storage clear
SER	14	I	Serial input
Q <sub>A</sub>	15	O	Output A
V <sub>CC</sub>	16	P	Power pin
PAD	—	—	Thermal Pad (2)

(1) I = Input, O = Output, I/O = Input or Output, G = Ground, P = Power.

(2) BQB Package Only

## 6 Specifications

### 6.1 Absolute Maximum Ratings

over operating free-air temperature range (unless otherwise noted) <sup>(1)</sup>

		MIN	MAX	UNIT	
V <sub>CC</sub>	Supply voltage	-0.5	7	V	
V <sub>I</sub>	Input voltage <sup>(2)</sup>	-0.5	7	V	
V <sub>O</sub>	Voltage range applied to any output in the high-impedance or power-off state <sup>(2)</sup>	-0.5	7	V	
V <sub>O</sub>	Output voltage <sup>(2) (3)</sup>	-0.5	V <sub>CC</sub> + 0.5	V	
I <sub>IK</sub>	Input clamp current	V <sub>I</sub> < 0	-20	mA	
I <sub>OK</sub>	Output clamp current	V <sub>O</sub> < 0	-50	mA	
I <sub>O</sub>	Continuous output current	V <sub>O</sub> = 0 to V <sub>CC</sub>	-25	25	mA
T <sub>stg</sub>	Storage temperature	-65	150	°C	

- (1) Stresses beyond those listed under *Absolute Maximum Ratings* may cause permanent damage to the device. These are stress ratings only, which do not imply functional operation of the device at these or any other conditions beyond those indicated under *Recommended Operating Conditions*. Exposure to absolute-maximum-rated conditions for extended periods may affect device reliability.
- (2) The input and output negative-voltage ratings may be exceeded if the input and output current ratings are observed.
- (3) The value is limited to 5.5 V maximum.

### 6.2 ESD Ratings

		VALUE	UNIT
V <sub>(ESD)</sub>	Electrostatic discharge	Human body model (HBM), per ANSI/ESDA/JEDEC JS-001 <sup>(1)</sup>	±2000
		Charged-device model (CDM), per JEDEC specification JESD22-C101 <sup>(2)</sup>	±1000

- (1) JEDEC document JEP155 states that 500-V HBM allows safe manufacturing with a standard ESD control process.
- (2) JEDEC document JEP157 states that 250-V CDM allows safe manufacturing with a standard ESD control process.

### 6.3 Recommended Operating Conditions

over operating free-air temperature range (unless otherwise noted)<sup>(1)</sup>

		SN74LV594A		UNIT
		MIN	MAX	
V <sub>CC</sub>	Supply voltage	2	5.5	V
V <sub>IH</sub>	High-level input voltage	V <sub>CC</sub> = 2 V	1.5	V
		V <sub>CC</sub> = 2.3 V to 2.7 V	V <sub>CC</sub> × 0.7	
		V <sub>CC</sub> = 3 V to 3.6 V	V <sub>CC</sub> × 0.7	
		V <sub>CC</sub> = 4.5 V to 5.5 V	V <sub>CC</sub> × 0.7	
V <sub>IL</sub>	Low-level input voltage	V <sub>CC</sub> = 2 V	0.5	V
		V <sub>CC</sub> = 2.3 V to 2.7 V	V <sub>CC</sub> × 0.3	
		V <sub>CC</sub> = 3 V to 3.6 V	V <sub>CC</sub> × 0.3	
		V <sub>CC</sub> = 4.5 V to 5.5 V	V <sub>CC</sub> × 0.3	
V <sub>I</sub>	Input voltage	0	5.5	V
V <sub>O</sub>	Output voltage	0	V <sub>CC</sub>	V
I <sub>OH</sub>	High-level input current	V <sub>CC</sub> = 2 V	-50	μA
		V <sub>CC</sub> = 2.3 V to 2.7 V	-2	
		V <sub>CC</sub> = 3 V to 3.6 V	6	
		V <sub>CC</sub> = 4.5 V to 5.5 V	-12	
I <sub>OL</sub>	Low-level output current	V <sub>CC</sub> = 2 V	50	μA
		V <sub>CC</sub> = 2.3 V to 2.7 V	2	
		V <sub>CC</sub> = 3 V to 3.6 V	6	
		V <sub>CC</sub> = 4.5 V to 5.5 V	12	
Δt/Δv	Input transition rise or fall rate	V <sub>CC</sub> = 2.3 V to 2.7 V	200	ns/V
		V <sub>CC</sub> = 3 V to 3.6 V	100	
		V <sub>CC</sub> = 4.5 V to 5.5 V	20	
T <sub>A</sub>	Operating free-air temperature	-40	125	°C

(1) All unused inputs of the device must be held at V<sub>CC</sub> or GND to ensure proper device operation. Refer to the TI application report *Implications of Slow or Floating CMOS Inputs*, [SCBA004](#).

### 6.4 Thermal Information

THERMAL METRIC <sup>(1)</sup>		SN74LV594A				UNIT
		BQB (WQFN)	D (SOIC)	DB (SSOP)	PW (TSSOP)	
		16 PINS	16 PINS	16 PINS	16 PINS	
R <sub>θJA</sub>	Junction-to-ambient thermal resistance	85.9	80.2	97.8	106.1	°C/W
R <sub>θJC(top)</sub>	Junction-to-case (top) thermal resistance	82.4	40.3	48.1	40.8	
R <sub>θJB</sub>	Junction-to-board thermal resistance	55.6	38	48.5	51.1	
ψ <sub>JT</sub>	Junction-to-top characterization parameter	9.4	9	10	3.8	
ψ <sub>JB</sub>	Junction-to-board characterization parameter	55.6	37.7	47.9	50.6	
R <sub>θJC(bot)</sub>	Junction-to-case (bottom) thermal resistance	33.3	N/A	N/A	N/A	

(1) For more information about traditional and new thermal metrics, see the *IC Package Thermal Metrics* application report, [SPRA953](#).

## 6.5 Electrical Characteristics

over operating free-air temperature range (unless otherwise noted)

PARAMETER	TEST CONDITIONS	V <sub>CC</sub>	SN54LV594A			SN74LV594A –40°C TO 85°C			SN74LV594A –40°C TO 125°C			UNIT
			MIN	TYP	MAX	MIN	TYP	MAX	MIN	TYP	MAX	
V <sub>OH</sub>	I <sub>OH</sub> = –50 μA	2 V to 5.5 V	V <sub>CC</sub> – 0.1			V <sub>CC</sub> – 0.1			V <sub>CC</sub> – 0.1			V
	I <sub>OH</sub> = –2 μA	2.3 V	2			2			2			
	I <sub>OH</sub> = –6 μA	3 V	2.48			2.48			2.48			
	I <sub>OH</sub> = –12 μA	4.5 V	3.8			3.8			3.8			
V <sub>OL</sub>	I <sub>OH</sub> = –50 μA	2 V to 5.5 V	0.1			0.1			0.1			V
	I <sub>OH</sub> = –2 μA	2.3 V	0.4			0.4			0.4			
	I <sub>OH</sub> = –6 μA	3 V	0.44			0.44			0.44			
	I <sub>OH</sub> = –12 μA	4.5 V	0.55			0.55			0.55			
I <sub>I</sub>	V <sub>I</sub> = 5.5 V or GND	0 to 5.5 V	±1			±1			±1			μA
I <sub>CC</sub>	V <sub>I</sub> = V <sub>CC</sub> of GND, I <sub>O</sub> = 0	5.5 V	20			20			20			μA
I <sub>off</sub>	V <sub>I</sub> or V <sub>O</sub> = 0 to 5.5 V	0	5			5			5			μA
C <sub>i</sub>	V <sub>I</sub> = V <sub>CC</sub> or GND	3.3 V	3.5			3.5			3.5			pF

## 6.6 Switching Characteristics: V<sub>CC</sub> = 2.5 V ± 0.2 V

over recommended operating free-air temperature range, V<sub>CC</sub> = 2.5 V ± 0.2 V (unless otherwise noted). See Figure 6-1.

PARAMETER	FROM (INPUT)	TO (OUTPUT)	LOAD CAPACITANCE	T <sub>A</sub> = 25°C			SN74LV594A –40°C TO 85°C		SN74LV594A –40°C TO 125°C		UNIT		
				MIN	TYP	MAX	MIN	MAX	MIN	MAX			
f <sub>max</sub>			C <sub>L</sub> = 15 pF	65 <sup>(1)</sup>	80 <sup>(1)</sup>		45		35	MHz			
			C <sub>L</sub> = 50 pF	60	70		40		30				
t <sub>PLH</sub>	SRCLK	Q <sub>A</sub> – Q <sub>H</sub>	C <sub>L</sub> = 15 pF	6.4 <sup>(1)</sup>	10.6 <sup>(1)</sup>		1	11.1	1	12.5	ns		
t <sub>PHL</sub>				6.3 <sup>(1)</sup>	10.4 <sup>(1)</sup>		1	11.1	1	12.5			
t <sub>PLH</sub>		Q <sub>H'</sub>		7.4 <sup>(1)</sup>	12.1 <sup>(1)</sup>		1	12.8	1	15			
t <sub>PHL</sub>				7.2 <sup>(1)</sup>	11.6 <sup>(1)</sup>		1	12.8	1	15			
t <sub>PHL</sub>	RCLK	Q <sub>A</sub> – Q <sub>H</sub>		7.9 <sup>(1)</sup>	12.7 <sup>(1)</sup>		1	13.6	1	15.5			
t <sub>PHL</sub>		Q <sub>H'</sub>		7.4 <sup>(1)</sup>	11.9 <sup>(1)</sup>		1	13.1	1	15.5			
t <sub>PLH</sub>	SRCLR	Q <sub>A</sub> – Q <sub>H</sub>		C <sub>L</sub> = 50 pF	9.5	14.1		1	14.6	1		17	ns
t <sub>PHL</sub>					10.8	15.5		1	17.2	1		19.5	
t <sub>PLH</sub>		Q <sub>H'</sub>	10.6		15.7		1	16.5	1	18.5			
t <sub>PHL</sub>			11.3		16.1		1	18.6	1	20.5			
t <sub>PHL</sub>	RCLR	Q <sub>A</sub> – Q <sub>H</sub>	12.1		17.4		1	19	1	21			
		Q <sub>H'</sub>	11.6		16.5		1	18.6	1	20.6			

(1) On products compliant to MIL-PRF-38535, this parameter is not production tested.

## 6.7 Switching Characteristics: $V_{CC} = 3.3\text{ V} \pm 0.3\text{ V}$

over recommended operating free-air temperature range,  $V_{CC} = 3.3\text{ V} \pm 0.3\text{ V}$  (unless otherwise noted). See [Figure 6-1](#).

PARAMETER	FROM (INPUT)	TO (OUTPUT)	LOAD CAPACITANCE	$T_A = 25^\circ\text{C}$			SN74LV594A –40°C TO 85°C		SN74LV594A –40°C TO 125°C		UNIT
				MIN	TYP	MAX	MIN	MAX	MIN	MAX	
$f_{\max}$			$C_L = 15\text{ pF}$	80 <sup>(1)</sup>	120 <sup>(1)</sup>		70		60	MHz	
			$C_L = 50\text{ pF}$	55	105		50		40		
$t_{PLH}$	SRCLK	$Q_A - Q_H$	$C_L = 15\text{ pF}$		4.6 <sup>(1)</sup>	8 <sup>(1)</sup>	1	8.5	1	10.5	ns
$t_{PHL}$					4.9 <sup>(1)</sup>	8.2 <sup>(1)</sup>	1	8.8	1	10.5	
$t_{PLH}$	$Q_{H'}$			5.4 <sup>(1)</sup>	9.1 <sup>(1)</sup>	1	9.7	1	11.5		
$t_{PHL}$				5.5 <sup>(1)</sup>	9.2 <sup>(1)</sup>	1	9.9	1	11.6		
$t_{PHL}$	RCLK	$Q_A - Q_H$			6 <sup>(1)</sup>	9.8 <sup>(1)</sup>	1	10.6	1	12.1	
		$Q_{H'}$			5.6 <sup>(1)</sup>	9.2 <sup>(1)</sup>	1	10	1	12	
$t_{PLH}$	SRCLR	$Q_A - Q_H$	$C_L = 50\text{ pF}$				1	11.1	1	12.5	ns
$t_{PHL}$							1	13.1	1	15	
$t_{PLH}$	$Q_{H'}$					1	12.4	1	14		
$t_{PHL}$						1	13.9	1	15.5		
$t_{PHL}$	RCLR	$Q_A - Q_H$					1	14.4	1	16.1	
		$Q_{H'}$					1	14	1	16	

(1) On products compliant to MIL-PRF-38535, this parameter is not production tested.

## 6.8 Switching Characteristics: $V_{CC} = 5\text{ V} \pm 0.5\text{ V}$

over recommended operating free-air temperature range,  $V_{CC} = 5\text{ V} \pm 0.5\text{ V}$  (unless otherwise noted). See [Figure 6-1](#).

PARAMETER	FROM (INPUT)	TO (OUTPUT)	LOAD CAPACITANCE	$T_A = 25^\circ\text{C}$			SN74LV594A –40°C TO 85°C		SN74LV594A –40°C TO 125°C		UNIT
				MIN	TYP	MAX	MIN	MAX	MIN	MAX	
$f_{\max}$			$C_L = 15\text{ pF}$	135 <sup>(1)</sup>	170 <sup>(1)</sup>		115		105	MHz	
			$C_L = 50\text{ pF}$	120	140		95		85		
$t_{PLH}$	SRCLK	$Q_A - Q_H$	$C_L = 15\text{ pF}$		3.3 <sup>(1)</sup>	6.2 <sup>(1)</sup>	1	6.5	1	8	ns
$t_{PHL}$					3.7 <sup>(1)</sup>	6.5 <sup>(1)</sup>	1	6.9	1	8.5	
$t_{PLH}$	$Q_{H'}$			3.7 <sup>(1)</sup>	6.8 <sup>(1)</sup>	1	7.2	1	8.5		
$t_{PHL}$				4.1 <sup>(1)</sup>	7.2 <sup>(1)</sup>	1	7.6	1	9		
$t_{PHL}$	RCLK	$Q_A - Q_H$			4.5 <sup>(1)</sup>	7.6 <sup>(1)</sup>	1	8.2	1	9.5	
		$Q_{H'}$			4.1 <sup>(1)</sup>	7.1 <sup>(1)</sup>	1	7.6	1	9	
$t_{PLH}$	SRCLR	$Q_A - Q_H$	$C_L = 50\text{ pF}$		4.9	7.8	1	8.3	1	9.6	ns
$t_{PHL}$					5.8	8.9	1	9.7	1	11	
$t_{PLH}$	$Q_{H'}$			5.5	8.6	1	9.1	1	10.5		
$t_{PHL}$				6	9.2	1	10.1	1	11.5		
$t_{PHL}$	RCLR	$Q_A - Q_H$			6.6	10	1	10.7	1	12	
		$Q_{H'}$			6	9.2	1	10.1	1	11.5	

(1) On products compliant to MIL-PRF-38535, this parameter is not production tested.

## 6.9 Timing Requirements: $V_{CC} = 2.5\text{ V} \pm 0.2\text{ V}$

over recommended operating free-air temperature range,  $V_{CC} = 2.5\text{ V} \pm 0.2\text{ V}$ . See [Figure 6-1](#).

			$T_A = 25^\circ\text{C}$		SN74LV594A –40°C TO 85°C		SN74LV594A –40°C TO 125°C		UNIT
			MIN	MAX	MIN	MAX	MIN	MAX	
$t_w$	Pulse duration	RCLK or SRCLK high or low	7		7.5		8.5		ns
		$\overline{\text{RCKR}}$ or $\overline{\text{SCRCLR}}$ low	6		6.5		7.5		
$t_{su}$	Setup time	SER before SRCLK $\uparrow$	5.5		5.5		6		ns
		SRCLK $\uparrow$ before RCLK $\uparrow$	8		9		10		
		$\overline{\text{SCRCLR}}$ low before RCLK $\uparrow$ <sup>(1)</sup>	8.5		9.5		10.5		
		$\overline{\text{SRCLR}}$ high (inactive) before SRCLK $\uparrow$	6		6.8		7.5		
		RCLK high (inactive) before RCLK $\uparrow$	6.7		7.6		8.5		
$t_h$	Hold time	SER after SRCLK $\uparrow$	1.5		1.5		2		ns

- (1) This setup time allows the storage register to receive stable data from the shift register. The clocks can be tied together, in which case the shift register is one clock pulse ahead of the storage register.

## 6.10 Timing Requirements: $V_{CC} = 3.3\text{ V} \pm 0.3\text{ V}$

over recommended operating free-air temperature range,  $V_{CC} = 3.3\text{ V} \pm 0.3\text{ V}$ . See [Figure 6-1](#).

			$T_A = 25^\circ\text{C}$		SN74LV594A –40°C TO 85°C		SN74LV594A –40°C TO 125°C		UNIT
			MIN	MAX	MIN	MAX	MIN	MAX	
$t_w$	Pulse duration	RCLK or SRCLK high or low	5.5		5.5		6.5		ns
		$\overline{\text{RCKR}}$ or $\overline{\text{SCRCLR}}$ low	5		5		6		
$t_{su}$	Setup time	SER before SRCLK $\uparrow$	3.5		3.5		4		ns
		SRCLK $\uparrow$ before RCLK $\uparrow$	8		8.5		9.5		
		$\overline{\text{SCRCLR}}$ low before RCLK $\uparrow$ <sup>(1)</sup>	8		9		10		
		$\overline{\text{SRCLR}}$ high (inactive) before SRCLK $\uparrow$	4.2		4.8		5.5		
		RCLK high (inactive) before RCLK $\uparrow$	4.6		5.3		6		
$t_h$	Hold time	SER after SRCLK $\uparrow$	1.5		1.5		2		ns

- (1) This setup time allows the storage register to receive stable data from the shift register. The clocks can be tied together, in which case the shift register is one clock pulse ahead of the storage register.

### 6.11 Timing Requirements: $V_{CC} = 5\text{ V} \pm 0.5\text{ V}$

over recommended operating free-air temperature range,  $V_{CC} = 2.5\text{ V} \pm 0.2\text{ V}$ . See [Figure 6-1](#).

			$T_A = 25^\circ\text{C}$		SN74LV594A –40°C TO 85°C		SN74LV594A –40°C TO 125°C		UNIT
			MIN	MAX	MIN	MAX	MIN	MAX	
$t_w$	Pulse duration	RCLK or SRCLK high or low	5		5		6		ns
		RCKR or $\overline{\text{SCRCLR}}$ low	5.2		5.2		6.2		
$t_{su}$	Setup time	SER before SRCLK $\uparrow$	3		3		3.5		ns
		SRCLK $\uparrow$ before RCLK $\uparrow$	5		5		6		
		$\overline{\text{SCRCLR}}$ low before RCLK $\uparrow$ (1)	5		5		5.5		
		SRCLR high (inactive) before SRCLK $\uparrow$	2.9		3.3		4		
		RCLK high (inactive) before RCLK $\uparrow$	3.2		3.7		4.5		
$t_h$	Hold time	SER after SRCLK $\uparrow$	2		2		2.5		ns

(1) This setup time allows the storage register to receive stable data from the shift register. The clocks can be tied together, in which case the shift register is one clock pulse ahead of the storage register.

### 6.12 Noise Characteristics

over operating free-air temperature range (unless otherwise noted),  $V_{CC} = 3.3\text{ V}$ ,  $C_L = 50\text{ pF}$ ,  $T_A = 25^\circ\text{C}$

PARAMETER		MIN	TYP	MAX	UNIT
$V_{OL(P)}$	Quiet output, maximum dynamic $V_{OL}$		0.5	0.8	V
$V_{OL(V)}$	Quiet output, minimum dynamic $V_{OL}$		–0.1	–0.8	V
$V_{OH(V)}$	Quiet output, minimum dynamic $V_{OH}$		2.8		V
$V_{IH(V)}$	High-level dynamic input voltage	2.31			V
$V_{IL(V)}$	Low-level dynamic input voltage			0.99	V

### 6.13 Operating Characteristics

$T_A = 25^\circ\text{C}$

PARAMETER		TEST CONDITIONS	$V_{CC}$	TYP	UNIT
$C_{pd}$	Power dissipation capacitance	$f = 10\text{ MHz}$	3.3 V	93	pF
			5 V	112	

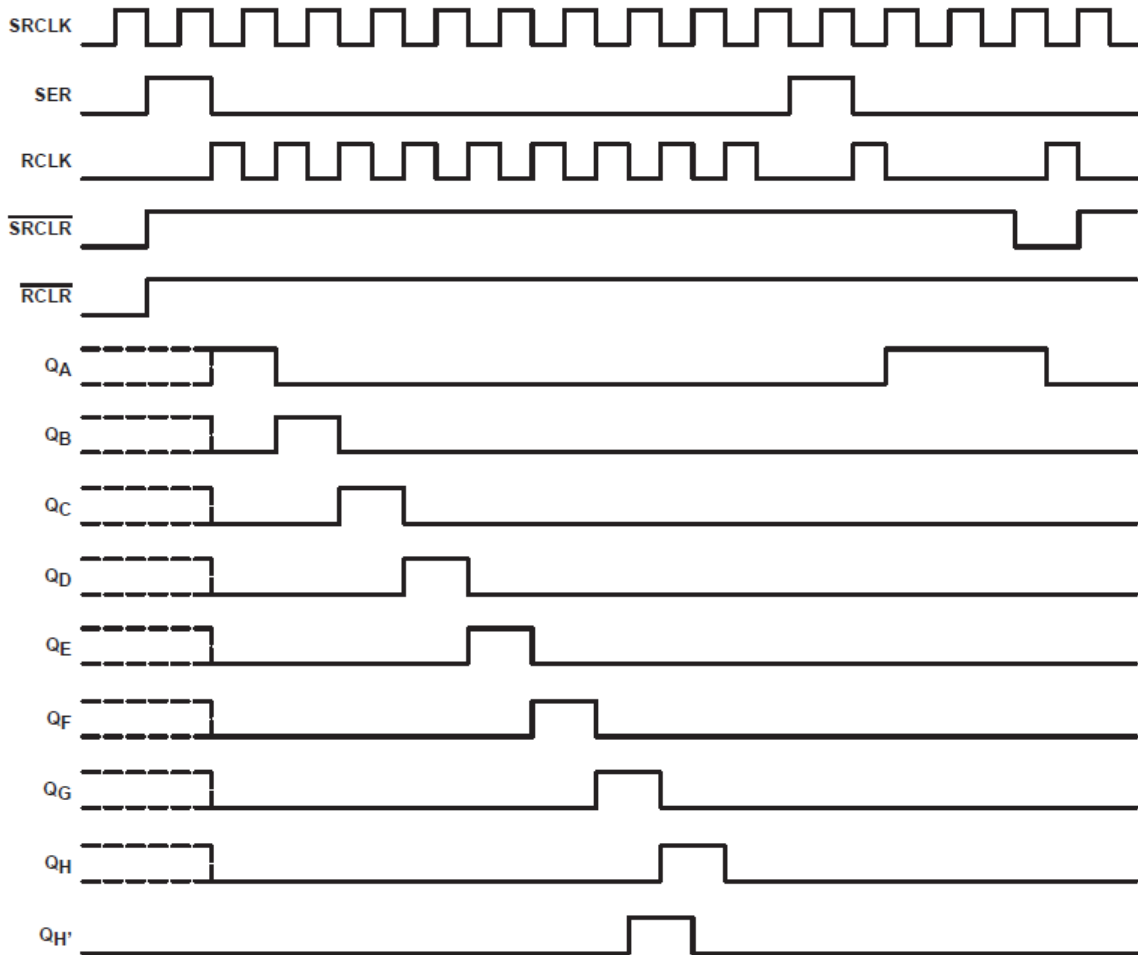
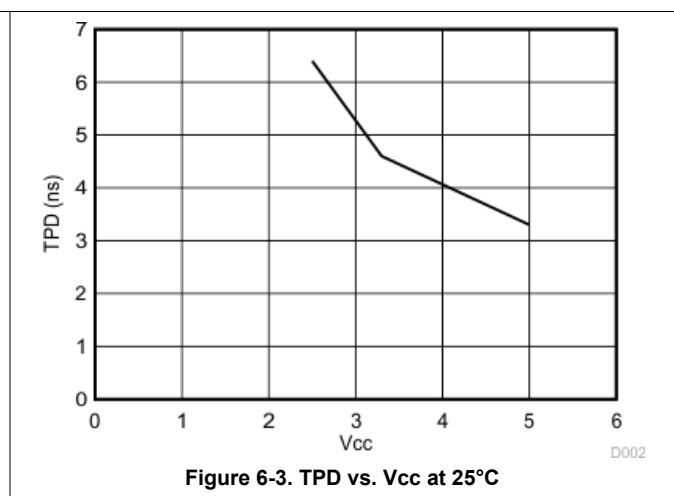
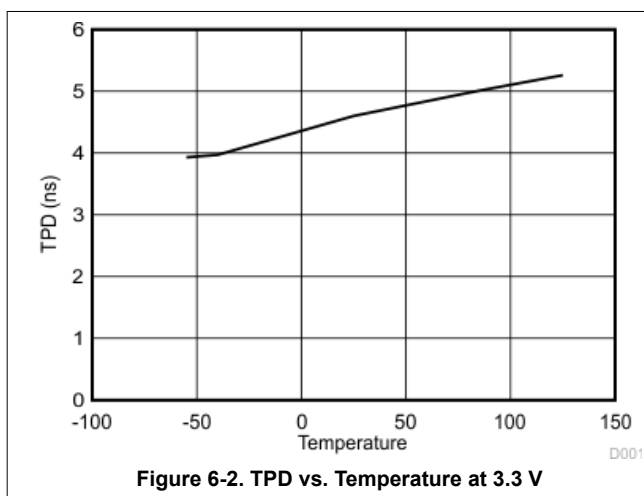
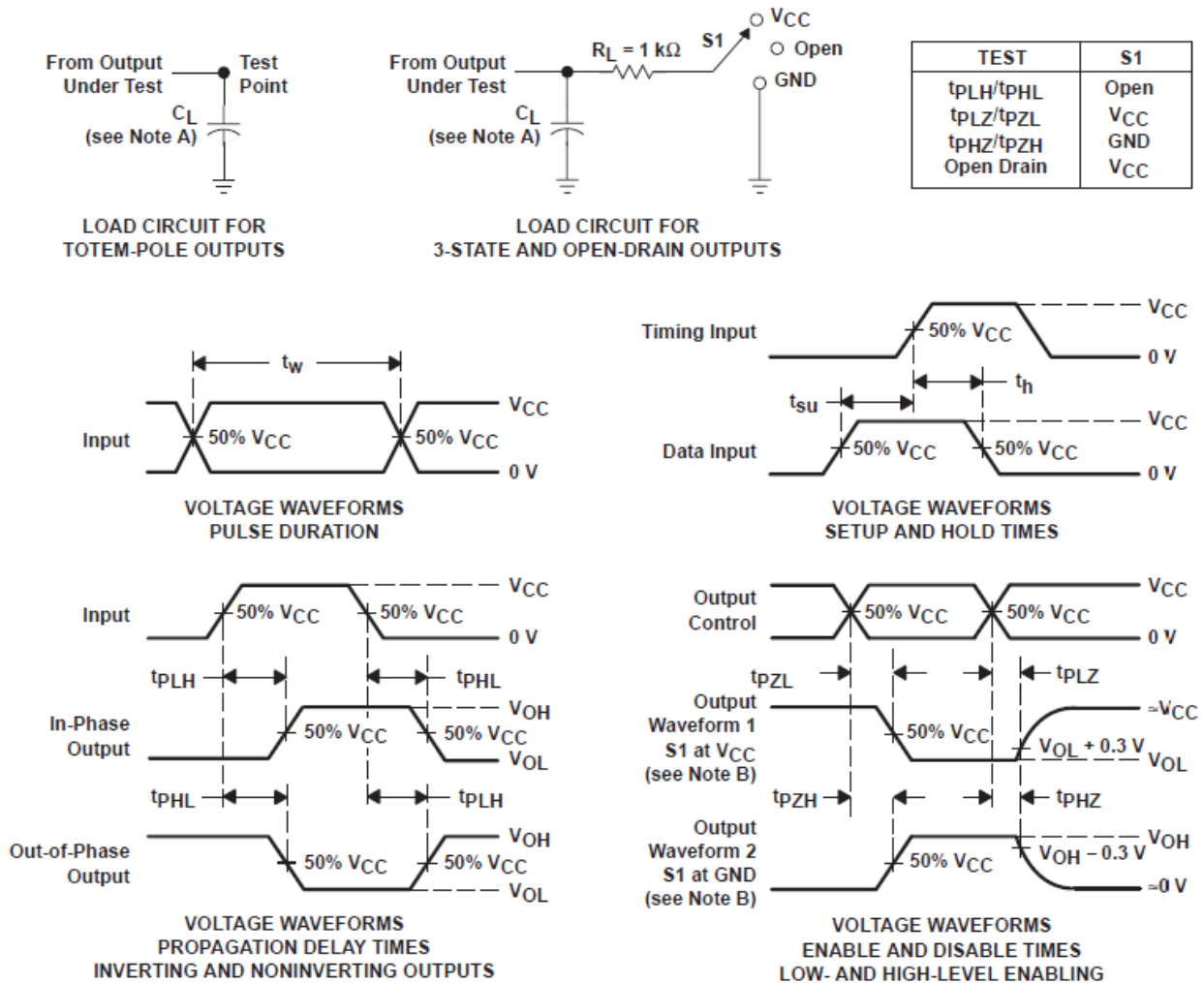

Figure 6-1. Timing Diagram

### 6.14 Typical Characteristics



## 7 Parameter Measurement Information



- NOTES:
- A.  $C_L$  includes probe and jig capacitance.
  - B. Waveform 1 is for an output with internal conditions such that the output is low, except when disabled by the output control. Waveform 2 is for an output with internal conditions such that the output is high, except when disabled by the output control.
  - C. All input pulses are supplied by generators having the following characteristics:  $PRR \leq 1\text{ MHz}$ ,  $Z_O = 50\ \Omega$ ,  $t_r \leq 3\text{ ns}$ ,  $t_f \leq 3\text{ ns}$ .
  - D. The outputs are measured one at a time, with one input transition per measurement.
  - E.  $t_{PLZ}$  and  $t_{PHZ}$  are the same as  $t_{dis}$ .
  - F.  $t_{PZL}$  and  $t_{PZH}$  are the same as  $t_{en}$ .
  - G.  $t_{PHL}$  and  $t_{PLH}$  are the same as  $t_{pd}$ .
  - H. All parameters and waveforms are not applicable to all devices.

Figure 7-1. Load Circuit and Voltage Waveforms

## 8 Detailed Description

### 8.1 Overview

The SN74LV594A devices are 8-bit shift registers designed for 2 V to 5.5 V  $V_{CC}$  operation.

These devices contain an 8-bit serial-in, parallel-out shift register that feeds an 8-bit D-type storage register. Separate clocks (RCLK, SRCLK) and direct overriding clear ( $\overline{RCLR}$ ,  $\overline{SRCLR}$ ) inputs are provided on the shift and storage registers. A serial output ( $Q_H$ ) is provided for cascading purposes. The shift-register (SRCLK) and storage-register (RCLK) clocks are positive-edge triggered. If the clocks are tied together, the shift register always is one clock pulse ahead of the storage register.

## 8.2 Functional Block Diagram

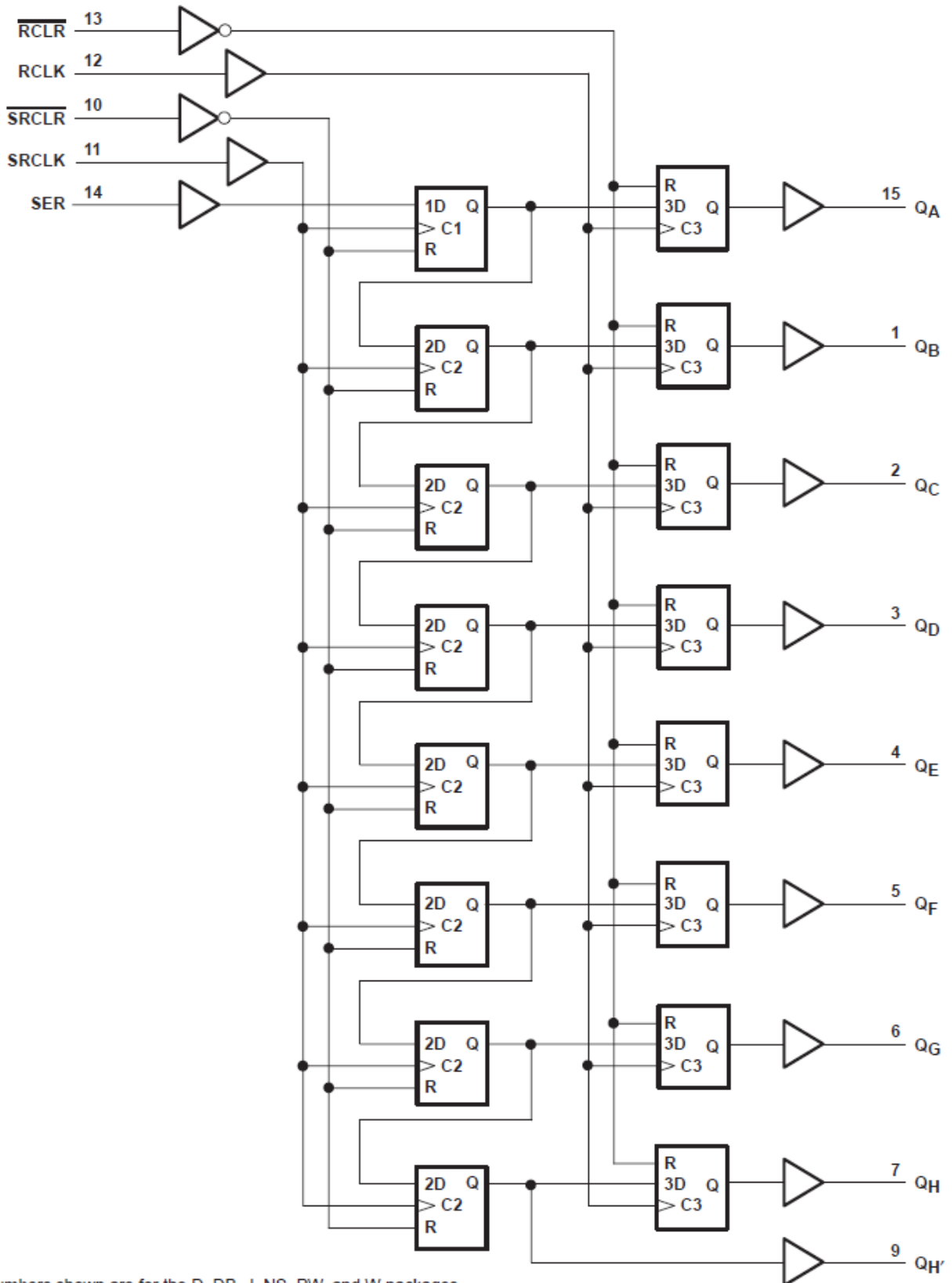

Pin numbers shown are for the D, DB, J, NS, PW, and W packages.

**Figure 8-1. Logic Diagram (Positive Logic)**

### 8.3 Feature Description

The device's wide operating range allows it to be used in a variety of systems that use different logic levels. The low propagation delay allows fast switching and higher speeds of operation. In addition, the low ground bounce stabilizes the performance of non-switching outputs while another output is switching.

### 8.4 Device Functional Modes

**Table 8-1. Function Table**

INPUTS					FUNCTION
SER	SRCLK	SRCLR	RCLK	RCLR	
X	X	L	X	X	Shift register is cleared.
L	↑	H	X	X	First stage of shift register goes low. Other stages store the data of previous stage, respectively.
H	↑	H	X	X	First stage of shift register goes high. Other stages store the data of previous stage, respectively.
L	↓	H	X	X	Shift register state is not changed.
X	X	X	X	L	Storage register is cleared.
X	X	X	↑	H	Shift register data is stored in the storage register.
X	X	X	↓	H	Storage register state is not changed.

## 9 Application and Implementation

### Note

Information in the following applications sections is not part of the TI component specification, and TI does not warrant its accuracy or completeness. TI's customers are responsible for determining suitability of components for their purposes, as well as validating and testing their design implementation to confirm system functionality.

### 9.1 Application Information

The SN74LV594A is a low drive CMOS device that can be used for a multitude of bus interface type applications where output ringing is a concern. The low drive and slow edge rates will minimize overshoot and undershoot on the outputs.

### 9.2 Typical Application

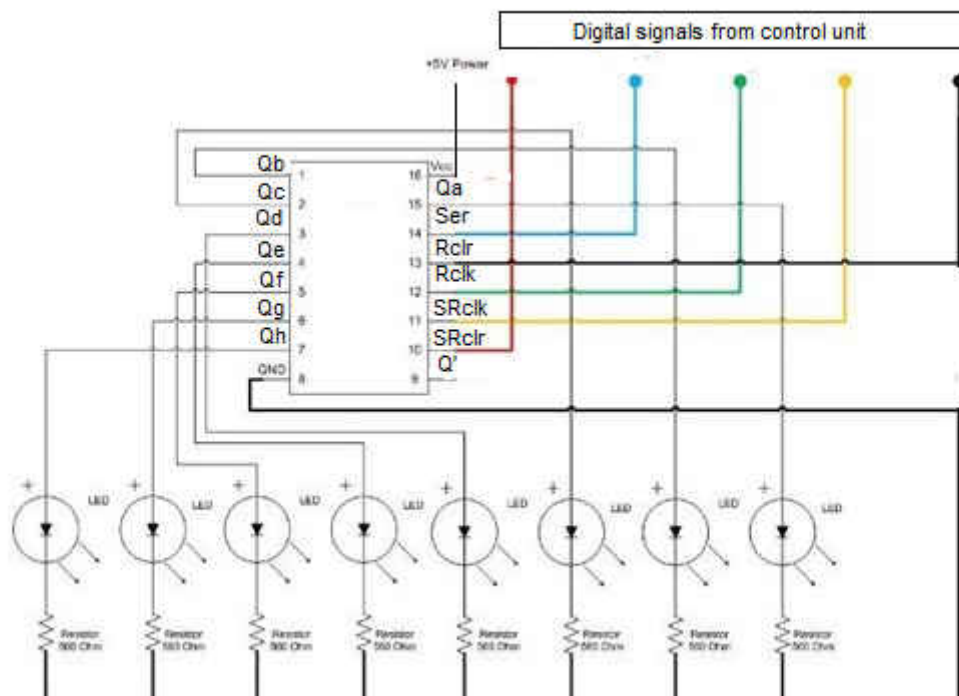

**Figure 9-1. Typical Application Schematic**

#### 9.2.1 Design Requirements

This device uses CMOS technology and has balanced output drive. Take care to avoid bus contention because it can drive currents that would exceed maximum limits. The high drive will also create fast edges into light loads so consider routing and load conditions to prevent ringing.

## 9.2.2 Detailed Design Procedure

- Recommended input conditions:
  - Rise time and fall time specs. See  $(\Delta t/\Delta V)$  in [Section 6.3](#).
  - Specified high and low levels. See  $(V_{IH}$  and  $V_{IL})$  in [Section 6.3](#).
  - Inputs are overvoltage tolerant allowing them to go as high as 5.5 V at any valid  $V_{CC}$ .
- Recommended output conditions:
  - Load currents should not exceed 25 mA per output and 50 mA total for the part.
  - Outputs should not be pulled above  $V_{CC}$ .

## 9.2.3 Application Curves

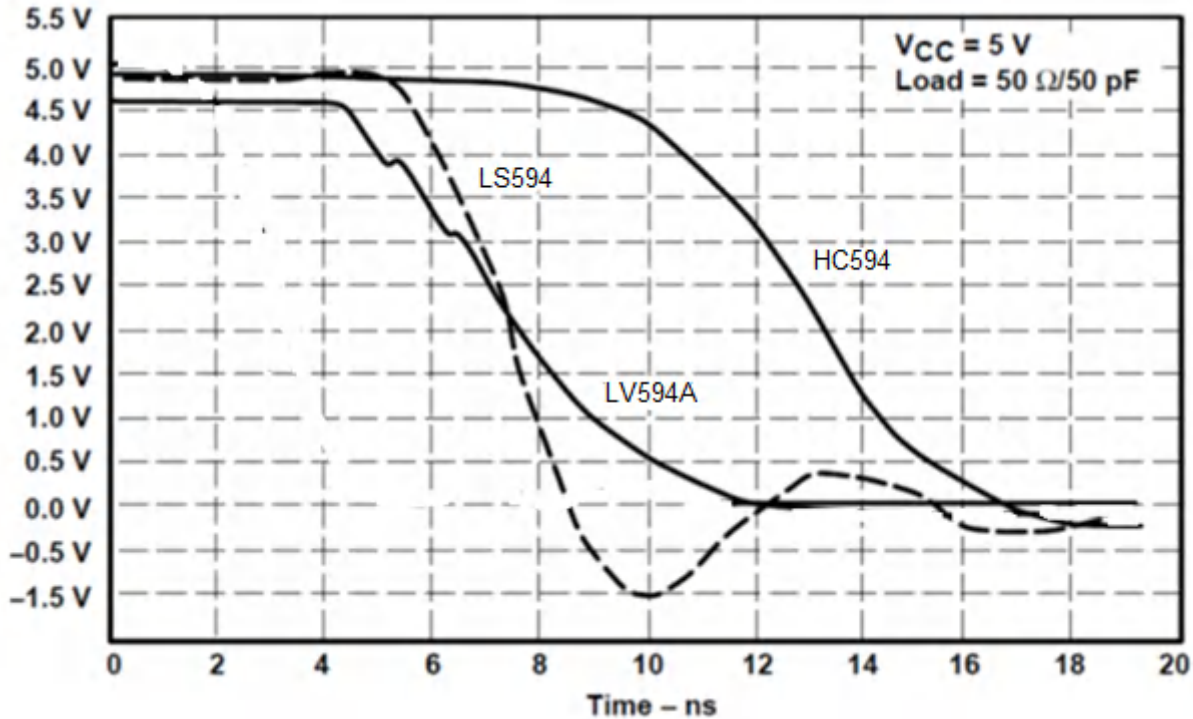

Figure 9-2. Switching Characteristics Comparison

## 9.3 Power Supply Recommendations

The power supply can be any voltage between the minimum and maximum supply voltage rating located in the [Section 6.3](#). Each  $V_{CC}$  terminal should have a good bypass capacitor to prevent power disturbance. For devices with a single supply, TI recommends a 0.1- $\mu\text{F}$  capacitor and if there are multiple  $V_{CC}$  terminals then TI recommends a 0.01- $\mu\text{F}$  or 0.022- $\mu\text{F}$  capacitor for each power terminal. Multiple bypass capacitors can be paralleled to reject different frequencies of noise. Frequencies of 0.1  $\mu\text{F}$  and 1  $\mu\text{F}$  are commonly used in parallel. The bypass capacitor should be installed as close as possible to the power terminal for best results.

## 9.4 Layout

### 9.4.1 Layout Guidelines

When using multiple bit logic devices inputs should not ever float.

In many cases, functions or parts of functions of digital logic devices are unused, for example, when only two inputs of a triple-input AND gate are used or only three of the four buffer gates are used. Such input pins should not be left unconnected because the undefined voltages at the outside connections result in undefined operational states. Specified below are the rules that must be observed under all circumstances. All unused inputs of digital logic devices must be connected to a high or low bias to prevent them from floating. The logic level that should be applied to any particular unused input depends on the function of the device. Generally they

will be tied to GND or  $V_{CC}$  whichever make more sense or is more convenient. Floating outputs is generally acceptable, unless the part is a transceiver. If the transceiver has an output enable pin it will disable the outputs section of the part when asserted. This will not disable the input section of the I.O's so they also cannot float when disabled.

### 9.4.2 Layout Example

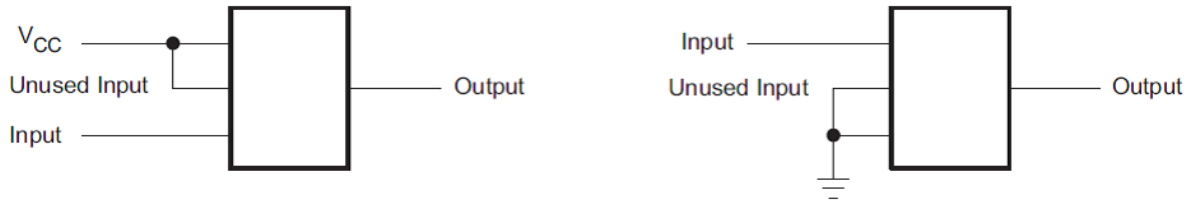

**Figure 9-3. Layout Example**

## 10 Device and Documentation Support

### 10.1 Receiving Notification of Documentation Updates

To receive notification of documentation updates, navigate to the device product folder on [ti.com](http://ti.com). Click on *Subscribe to updates* to register and receive a weekly digest of any product information that has changed. For change details, review the revision history included in any revised document.

### 10.2 Support Resources

TI E2E™ [support forums](#) are an engineer's go-to source for fast, verified answers and design help — straight from the experts. Search existing answers or ask your own question to get the quick design help you need.

Linked content is provided "AS IS" by the respective contributors. They do not constitute TI specifications and do not necessarily reflect TI's views; see TI's [Terms of Use](#).

### 10.3 Trademarks

TI E2E™ is a trademark of Texas Instruments.

All trademarks are the property of their respective owners.

### 10.4 Electrostatic Discharge Caution



This integrated circuit can be damaged by ESD. Texas Instruments recommends that all integrated circuits be handled with appropriate precautions. Failure to observe proper handling and installation procedures can cause damage.

ESD damage can range from subtle performance degradation to complete device failure. Precision integrated circuits may be more susceptible to damage because very small parametric changes could cause the device not to meet its published specifications.

### 10.5 Glossary

[TI Glossary](#) This glossary lists and explains terms, acronyms, and definitions.

## 11 Mechanical, Packaging, and Orderable Information

The following pages include mechanical, packaging, and orderable information. This information is the most current data available for the designated devices. This data is subject to change without notice and revision of this document. For browser-based versions of this data sheet, refer to the left-hand navigation.

**PACKAGING INFORMATION**

Orderable Device	Status (1)	Package Type	Package Drawing	Pins	Package Qty	Eco Plan (2)	Lead finish/ Ball material (6)	MSL Peak Temp (3)	Op Temp (°C)	Device Marking (4/5)	Samples
SN74LV594ABQBR	ACTIVE	WQFN	BQB	16	3000	RoHS & Green	NIPDAU	Level-1-260C-UNLIM	-40 to 125	LV594A	<a href="#">Samples</a>
SN74LV594ADBR	ACTIVE	SSOP	DB	16	2000	RoHS & Green	NIPDAU	Level-1-260C-UNLIM	-40 to 125	LV594A	<a href="#">Samples</a>
SN74LV594ADR	ACTIVE	SOIC	D	16	2500	RoHS & Green	NIPDAU	Level-1-260C-UNLIM	-40 to 125	LV594A	<a href="#">Samples</a>
SN74LV594APWR	ACTIVE	TSSOP	PW	16	2000	RoHS & Green	NIPDAU   SN	Level-1-260C-UNLIM	-40 to 125	LV594A	<a href="#">Samples</a>
SN74LV594APWRG4	ACTIVE	TSSOP	PW	16	2000	RoHS & Green	NIPDAU	Level-1-260C-UNLIM	-40 to 125	LV594A	<a href="#">Samples</a>

(1) The marketing status values are defined as follows:

**ACTIVE:** Product device recommended for new designs.

**LIFEBUY:** TI has announced that the device will be discontinued, and a lifetime-buy period is in effect.

**NRND:** Not recommended for new designs. Device is in production to support existing customers, but TI does not recommend using this part in a new design.

**PREVIEW:** Device has been announced but is not in production. Samples may or may not be available.

**OBSELETE:** TI has discontinued the production of the device.

(2) **RoHS:** TI defines "RoHS" to mean semiconductor products that are compliant with the current EU RoHS requirements for all 10 RoHS substances, including the requirement that RoHS substance do not exceed 0.1% by weight in homogeneous materials. Where designed to be soldered at high temperatures, "RoHS" products are suitable for use in specified lead-free processes. TI may reference these types of products as "Pb-Free".

**RoHS Exempt:** TI defines "RoHS Exempt" to mean products that contain lead but are compliant with EU RoHS pursuant to a specific EU RoHS exemption.

**Green:** TI defines "Green" to mean the content of Chlorine (Cl) and Bromine (Br) based flame retardants meet JS709B low halogen requirements of <=1000ppm threshold. Antimony trioxide based flame retardants must also meet the <=1000ppm threshold requirement.

(3) MSL, Peak Temp. - The Moisture Sensitivity Level rating according to the JEDEC industry standard classifications, and peak solder temperature.

(4) There may be additional marking, which relates to the logo, the lot trace code information, or the environmental category on the device.

(5) Multiple Device Markings will be inside parentheses. Only one Device Marking contained in parentheses and separated by a "~" will appear on a device. If a line is indented then it is a continuation of the previous line and the two combined represent the entire Device Marking for that device.

(6) Lead finish/Ball material - Orderable Devices may have multiple material finish options. Finish options are separated by a vertical ruled line. Lead finish/Ball material values may wrap to two lines if the finish value exceeds the maximum column width.

**Important Information and Disclaimer:** The information provided on this page represents TI's knowledge and belief as of the date that it is provided. TI bases its knowledge and belief on information provided by third parties, and makes no representation or warranty as to the accuracy of such information. Efforts are underway to better integrate information from third parties. TI has taken and continues to take reasonable steps to provide representative and accurate information but may not have conducted destructive testing or chemical analysis on incoming materials and chemicals. TI and TI suppliers consider certain information to be proprietary, and thus CAS numbers and other limited information may not be available for release.

In no event shall TI's liability arising out of such information exceed the total purchase price of the TI part(s) at issue in this document sold by TI to Customer on an annual basis.

**OTHER QUALIFIED VERSIONS OF SN74LV594A :**

- Automotive : [SN74LV594A-Q1](#)

NOTE: Qualified Version Definitions:

- Automotive - Q100 devices qualified for high-reliability automotive applications targeting zero defects

**TAPE AND REEL INFORMATION**

**QUADRANT ASSIGNMENTS FOR PIN 1 ORIENTATION IN TAPE**

\*All dimensions are nominal

Device	Package Type	Package Drawing	Pins	SPQ	Reel Diameter (mm)	Reel Width W1 (mm)	A0 (mm)	B0 (mm)	K0 (mm)	P1 (mm)	W (mm)	Pin1 Quadrant
SN74LV594ABQBR	WQFN	BQB	16	3000	180.0	12.4	2.8	3.8	1.2	4.0	12.0	Q1
SN74LV594ADB	SSOP	DB	16	2000	330.0	16.4	8.35	6.6	2.4	12.0	16.0	Q1
SN74LV594ADR	SOIC	D	16	2500	330.0	16.4	6.5	10.3	2.1	8.0	16.0	Q1
SN74LV594APWR	TSSOP	PW	16	2000	330.0	12.4	6.9	5.6	1.6	8.0	12.0	Q1
SN74LV594APWR	TSSOP	PW	16	2000	330.0	12.4	6.9	5.6	1.6	8.0	12.0	Q1
SN74LV594APWRG4	TSSOP	PW	16	2000	330.0	12.4	6.9	5.6	1.6	8.0	12.0	Q1
SN74LV594APWRG4	TSSOP	PW	16	2000	330.0	12.4	6.9	5.6	1.6	8.0	12.0	Q1

**TAPE AND REEL BOX DIMENSIONS**

\*All dimensions are nominal

Device	Package Type	Package Drawing	Pins	SPQ	Length (mm)	Width (mm)	Height (mm)
SN74LV594ABQBR	WQFN	BQB	16	3000	210.0	185.0	35.0
SN74LV594ADBR	SSOP	DB	16	2000	356.0	356.0	35.0
SN74LV594ADR	SOIC	D	16	2500	340.5	336.1	32.0
SN74LV594APWR	TSSOP	PW	16	2000	353.0	353.0	32.0
SN74LV594APWR	TSSOP	PW	16	2000	356.0	356.0	35.0
SN74LV594APWRG4	TSSOP	PW	16	2000	356.0	356.0	35.0
SN74LV594APWRG4	TSSOP	PW	16	2000	356.0	356.0	35.0

D (R-PDSO-G16)

PLASTIC SMALL OUTLINE



- NOTES:
- A. All linear dimensions are in inches (millimeters).
  - B. This drawing is subject to change without notice.
  - C. Body length does not include mold flash, protrusions, or gate burrs. Mold flash, protrusions, or gate burrs shall not exceed 0.006 (0,15) each side.
  - D. Body width does not include interlead flash. Interlead flash shall not exceed 0.017 (0,43) each side.
  - E. Reference JEDEC MS-012 variation AC.



4220204/A 02/2017

NOTES:

1. All linear dimensions are in millimeters. Any dimensions in parenthesis are for reference only. Dimensioning and tolerancing per ASME Y14.5M.
2. This drawing is subject to change without notice.
3. This dimension does not include mold flash, protrusions, or gate burrs. Mold flash, protrusions, or gate burrs shall not exceed 0.15 mm per side.
4. This dimension does not include interlead flash. Interlead flash shall not exceed 0.25 mm per side.
5. Reference JEDEC registration MO-153.

# EXAMPLE BOARD LAYOUT

PW0016A

TSSOP - 1.2 mm max height

SMALL OUTLINE PACKAGE



LAND PATTERN EXAMPLE  
EXPOSED METAL SHOWN  
SCALE: 10X



SOLDER MASK DETAILS

4220204/A 02/2017

NOTES: (continued)

- 6. Publication IPC-7351 may have alternate designs.
- 7. Solder mask tolerances between and around signal pads can vary based on board fabrication site.

# EXAMPLE STENCIL DESIGN

PW0016A

TSSOP - 1.2 mm max height

SMALL OUTLINE PACKAGE

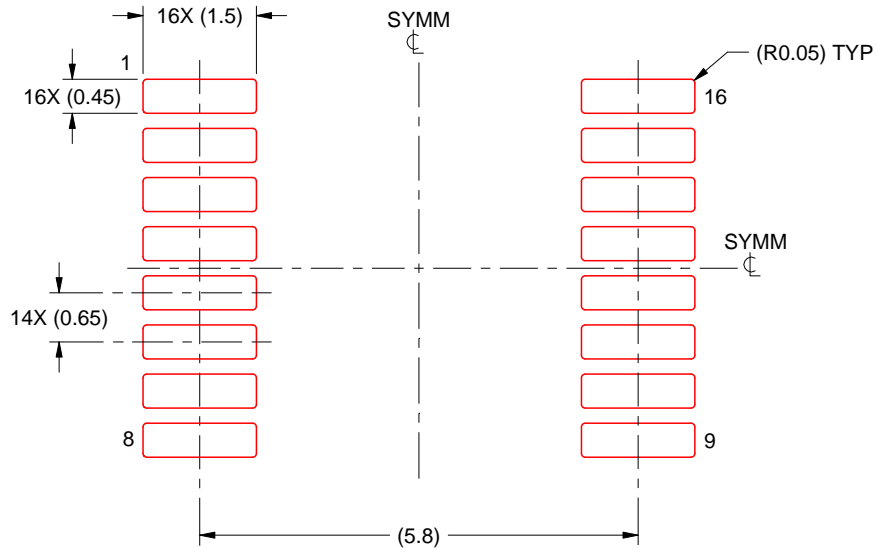

SOLDER PASTE EXAMPLE  
BASED ON 0.125 mm THICK STENCIL  
SCALE: 10X

4220204/A 02/2017

NOTES: (continued)

8. Laser cutting apertures with trapezoidal walls and rounded corners may offer better paste release. IPC-7525 may have alternate design recommendations.
9. Board assembly site may have different recommendations for stencil design.

# DB0016A



# PACKAGE OUTLINE

## SSOP - 2 mm max height

SMALL OUTLINE PACKAGE

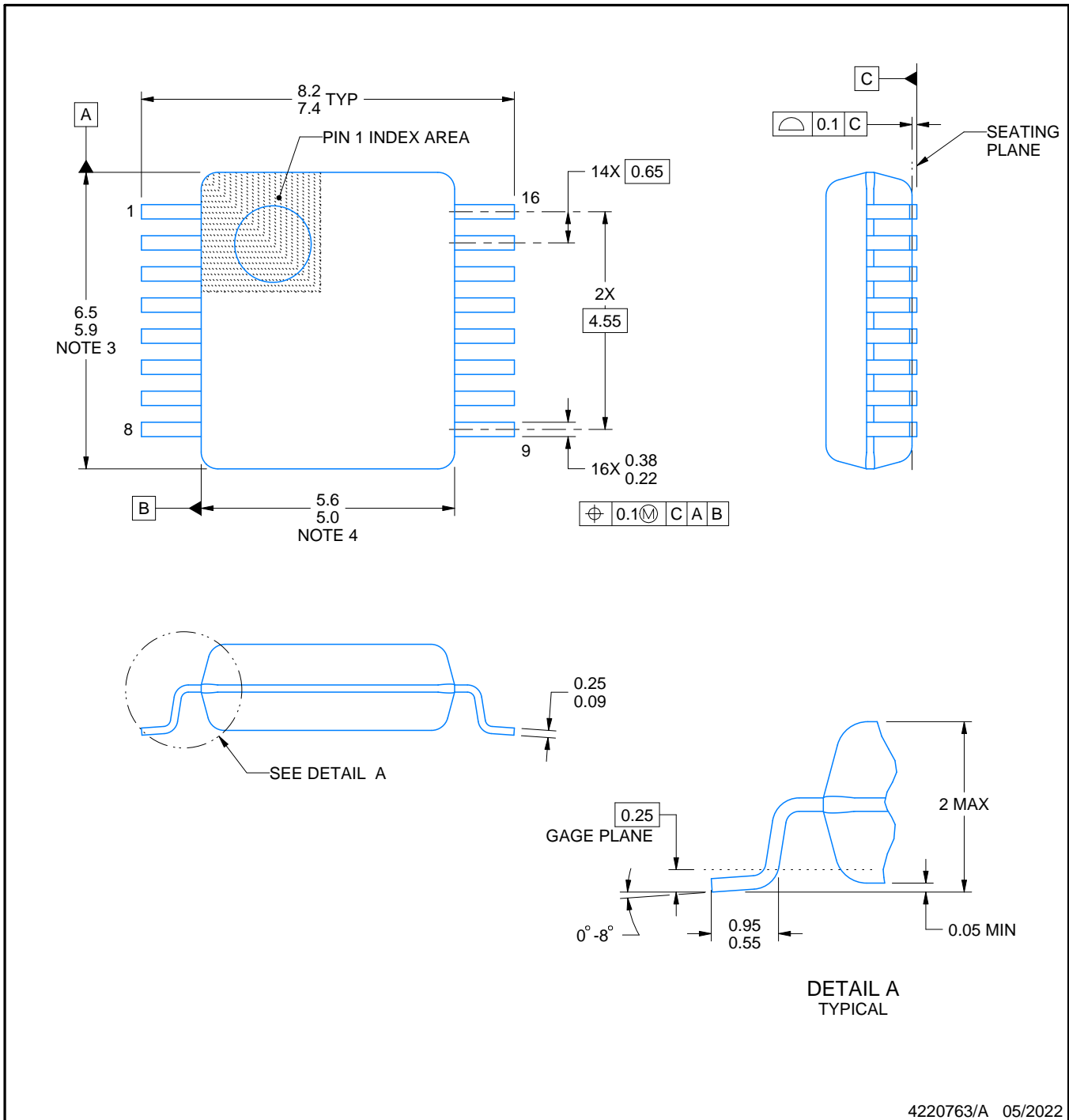

4220763/A 05/2022

### NOTES:

1. All linear dimensions are in millimeters. Any dimensions in parenthesis are for reference only. Dimensioning and tolerancing per ASME Y14.5M.
2. This drawing is subject to change without notice.
3. This dimension does not include mold flash, protrusions, or gate burrs. Mold flash, protrusions, or gate burrs shall not exceed 0.15 mm per side.
4. Reference JEDEC registration MO-150.

# EXAMPLE BOARD LAYOUT

DB0016A

SSOP - 2 mm max height

SMALL OUTLINE PACKAGE

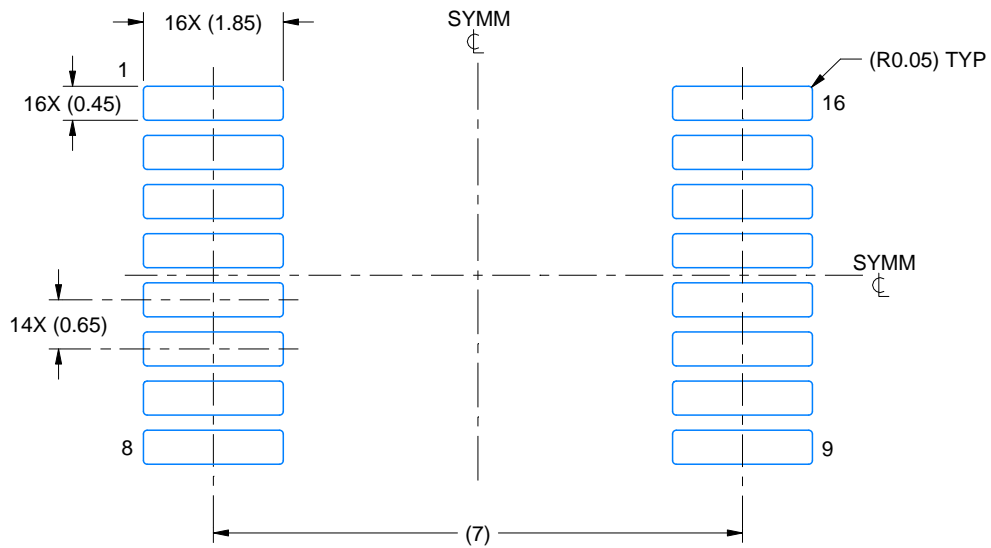

LAND PATTERN EXAMPLE  
EXPOSED METAL SHOWN  
SCALE: 10X

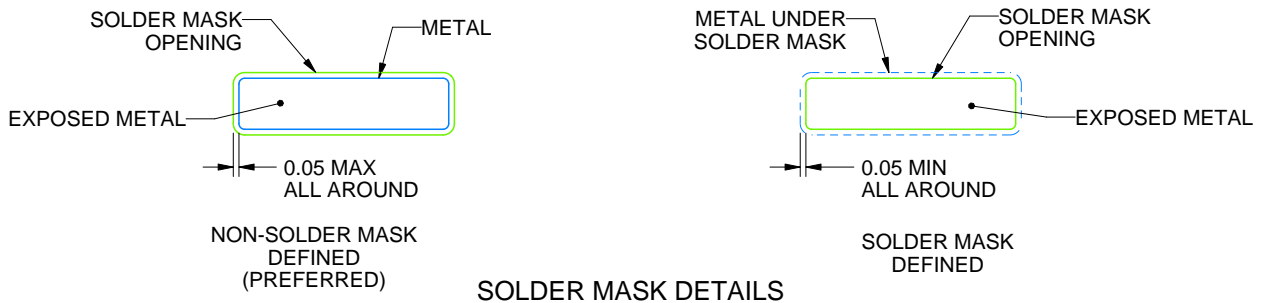

4220763/A 05/2022

NOTES: (continued)

- 5. Publication IPC-7351 may have alternate designs.
- 6. Solder mask tolerances between and around signal pads can vary based on board fabrication site.

# EXAMPLE STENCIL DESIGN

DB0016A

SSOP - 2 mm max height

SMALL OUTLINE PACKAGE

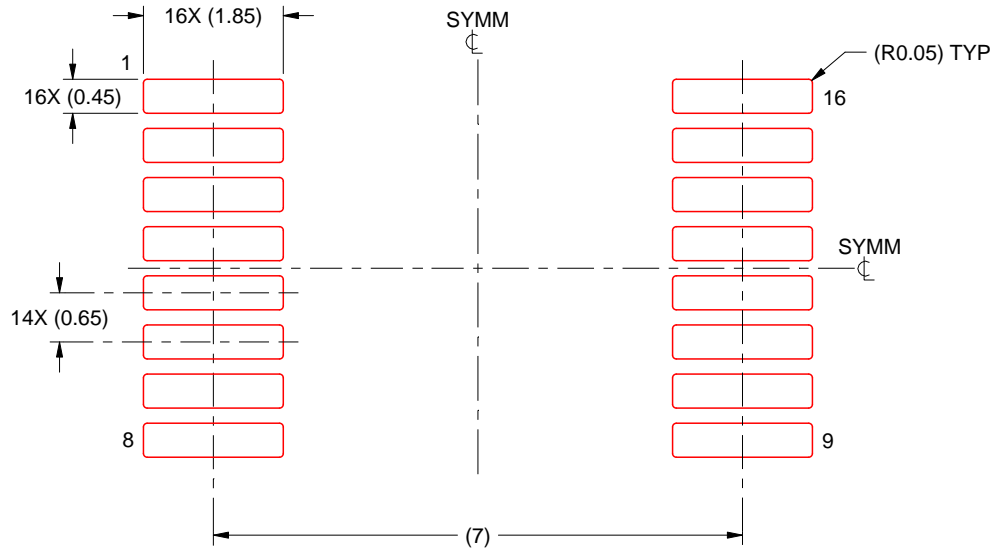

SOLDER PASTE EXAMPLE  
BASED ON 0.125 mm THICK STENCIL  
SCALE: 10X

4220763/A 05/2022

NOTES: (continued)

7. Laser cutting apertures with trapezoidal walls and rounded corners may offer better paste release. IPC-7525 may have alternate design recommendations.
8. Board assembly site may have different recommendations for stencil design.

## GENERIC PACKAGE VIEW

**BQB 16**

**WQFN - 0.8 mm max height**

2.5 x 3.5, 0.5 mm pitch

PLASTIC QUAD FLATPACK - NO LEAD

This image is a representation of the package family, actual package may vary.  
Refer to the product data sheet for package details.

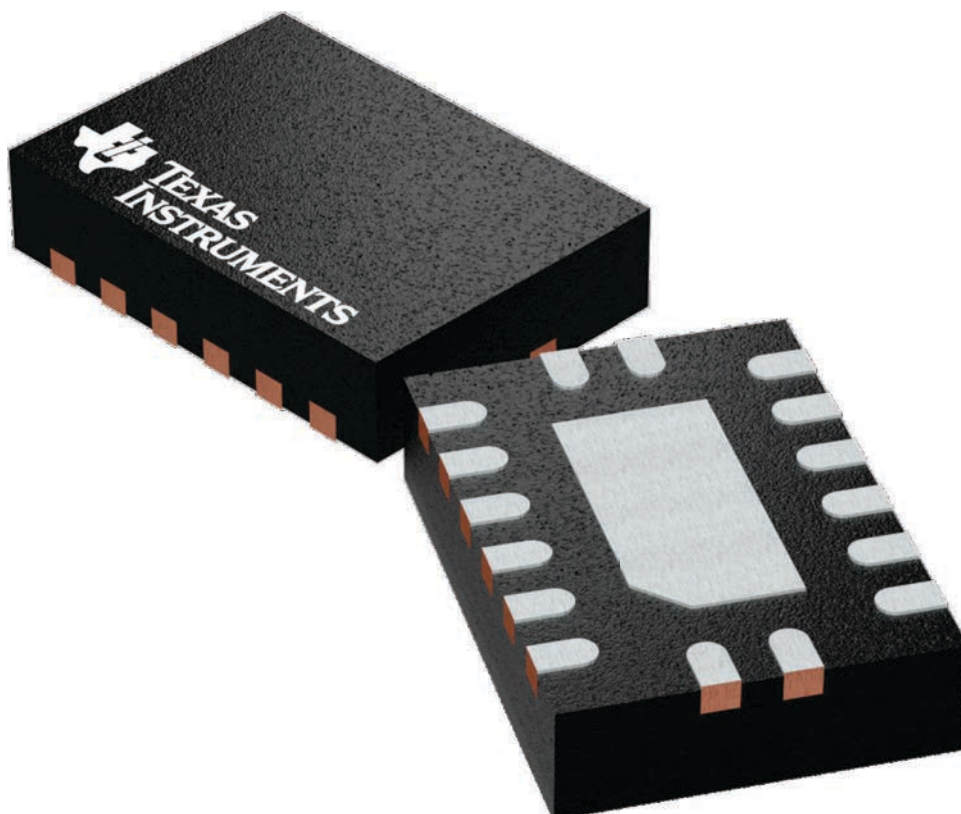

4226161/A

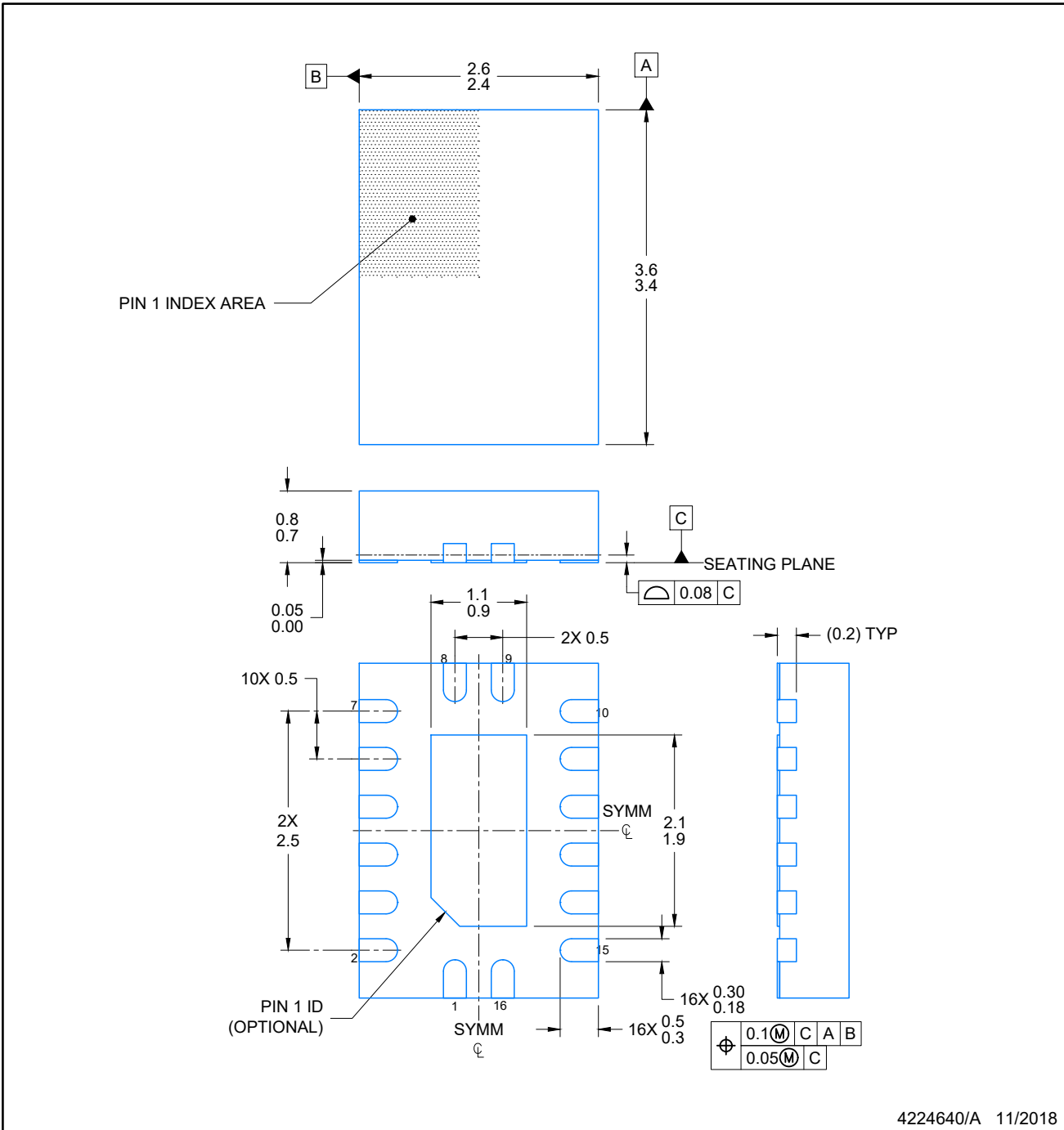

4224640/A 11/2018

NOTES:

1. All linear dimensions are in millimeters. Any dimensions in parenthesis are for reference only. Dimensioning and tolerancing per ASME Y14.5M.
2. This drawing is subject to change without notice.
3. The package thermal pad must be soldered to the printed circuit board for optimal thermal and mechanical performance.

# EXAMPLE BOARD LAYOUT

**BQB0016A**

**WQFN - 0.8 mm max height**

PLASTIC QUAD FLAT PACK-NO LEAD

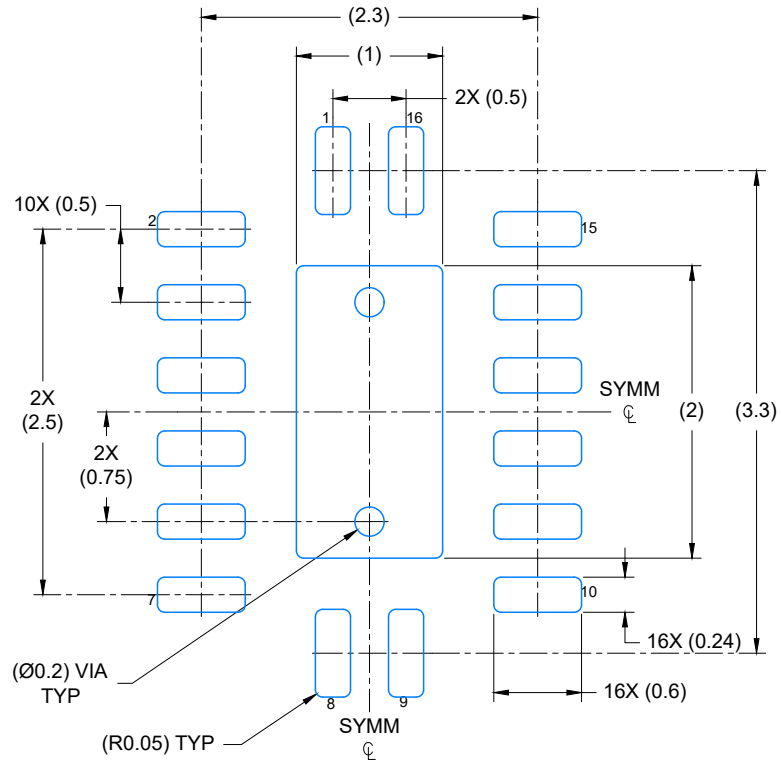

LAND PATTERN EXAMPLE  
EXPOSED METAL SHOWN  
SCALE: 20X

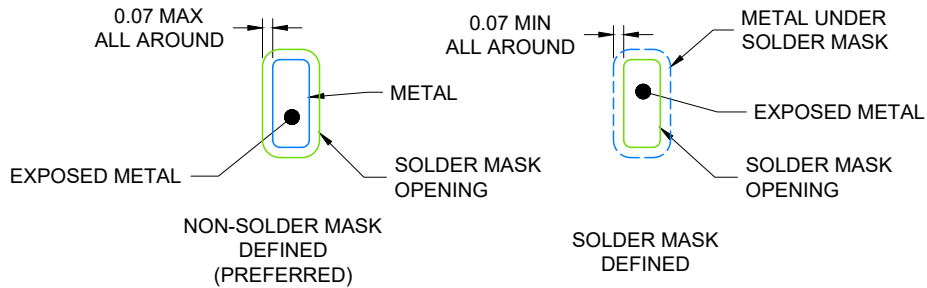

4224640/A 11/2018

NOTES: (continued)

4. This package is designed to be soldered to a thermal pad on the board. For more information, see Texas Instruments literature number SLUA271 ([www.ti.com/lit/sluea271](http://www.ti.com/lit/sluea271)).
5. Vias are optional depending on application, refer to device data sheet. If any vias are implemented, refer to their locations shown on this view. It is recommended that vias under paste be filled, plugged or tented.

# EXAMPLE STENCIL DESIGN

**BQB0016A**

**WQFN - 0.8 mm max height**

PLASTIC QUAD FLAT PACK-NO LEAD

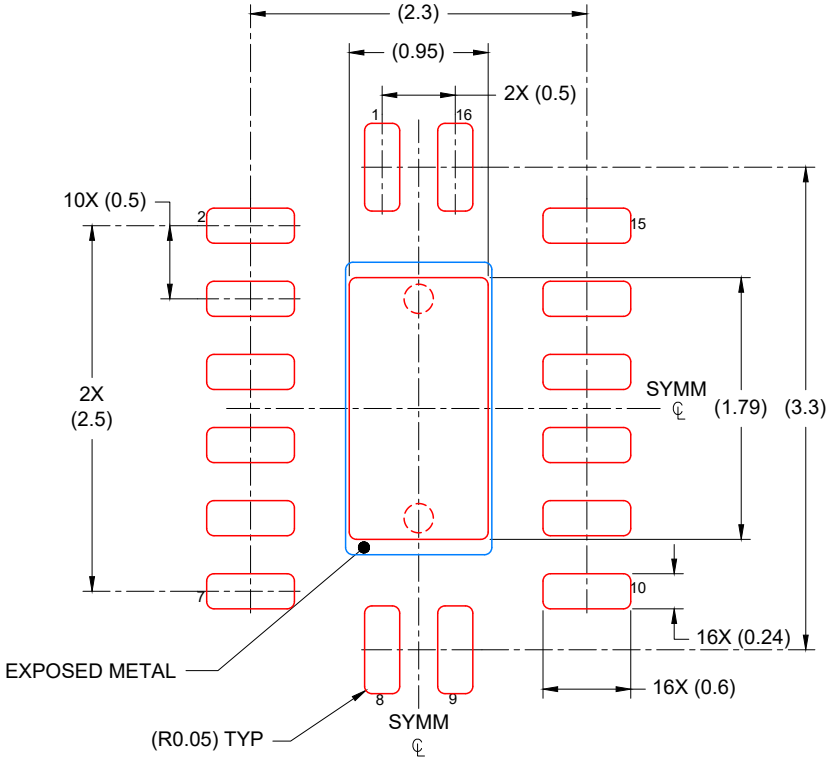

**SOLDER PASTE EXAMPLE**  
 BASED ON 0.125 mm THICK STENCIL

EXPOSED PAD  
 85% PRINTED COVERAGE BY AREA  
 SCALE: 20X

4224640/A 11/2018

NOTES: (continued)

- 6. Laser cutting apertures with trapezoidal walls and rounded corners may offer better paste release. IPC-7525 may have alternate design recommendations.

## IMPORTANT NOTICE AND DISCLAIMER

TI PROVIDES TECHNICAL AND RELIABILITY DATA (INCLUDING DATA SHEETS), DESIGN RESOURCES (INCLUDING REFERENCE DESIGNS), APPLICATION OR OTHER DESIGN ADVICE, WEB TOOLS, SAFETY INFORMATION, AND OTHER RESOURCES "AS IS" AND WITH ALL FAULTS, AND DISCLAIMS ALL WARRANTIES, EXPRESS AND IMPLIED, INCLUDING WITHOUT LIMITATION ANY IMPLIED WARRANTIES OF MERCHANTABILITY, FITNESS FOR A PARTICULAR PURPOSE OR NON-INFRINGEMENT OF THIRD PARTY INTELLECTUAL PROPERTY RIGHTS.

These resources are intended for skilled developers designing with TI products. You are solely responsible for (1) selecting the appropriate TI products for your application, (2) designing, validating and testing your application, and (3) ensuring your application meets applicable standards, and any other safety, security, regulatory or other requirements.

These resources are subject to change without notice. TI grants you permission to use these resources only for development of an application that uses the TI products described in the resource. Other reproduction and display of these resources is prohibited. No license is granted to any other TI intellectual property right or to any third party intellectual property right. TI disclaims responsibility for, and you will fully indemnify TI and its representatives against, any claims, damages, costs, losses, and liabilities arising out of your use of these resources.

TI's products are provided subject to [TI's Terms of Sale](#) or other applicable terms available either on [ti.com](https://www.ti.com) or provided in conjunction with such TI products. TI's provision of these resources does not expand or otherwise alter TI's applicable warranties or warranty disclaimers for TI products.

TI objects to and rejects any additional or different terms you may have proposed.

Mailing Address: Texas Instruments, Post Office Box 655303, Dallas, Texas 75265  
Copyright © 2024, Texas Instruments Incorporated

## Looking for pricing, stock, or lifecycle information?

Click below to explore more details on WIN SOURCE:

 [View SN74LV594APWTG4 on WIN SOURCE](#)

 [Texas Instruments](#) Information

## Optimize Your Supply Chain with WIN SOURCE Solutions

-  Global Sourcing Solution
-  Obsolete Management
-  Cost Control Management
-  Shortage Management
-  Alternative Solution
-  Excess Inventory Management