



THE DATASHEET OF TSM102AIPWRG4



FEATURES

- **OPERATIONAL AMPLIFIERS**
 - Low Supply Current...200 μ A/A
 - Medium Speed...2.1 MHz
 - Low-Level Output Voltage Close to V_{CC} ...0.1 V Typ ($R_L = 10\text{ k}\Omega$)
 - Input Common-Mode Voltage Range Includes Ground
- **COMPARATORS**
 - Low Supply Current...200 μ A/A ($V_{CC} = 5\text{ V}$)
 - Input Common-Mode Voltage Range Includes Ground
 - Low Output Saturation Voltage... Typically 250 mV ($I_{\text{sink}} = 4\text{ mA}$)
- **VOLTAGE REFERENCE**
 - Adjustable Output Voltage... V_{REF} to 36 V
 - Sink Current Capability...1 mA to 100 mA
 - 0.4% (A Grade) and 1% (Standard Grade) Precision
 - Latch-Up Immunity

APPLICATIONS

- Switch-Mode Power Supplies
- Battery Chargers
- Voltage and Current Sensing
- Power-Good, Overvoltage, Undervoltage, Overcurrent Detection
- Window Comparators
- Alarms, Detectors, and Sensors

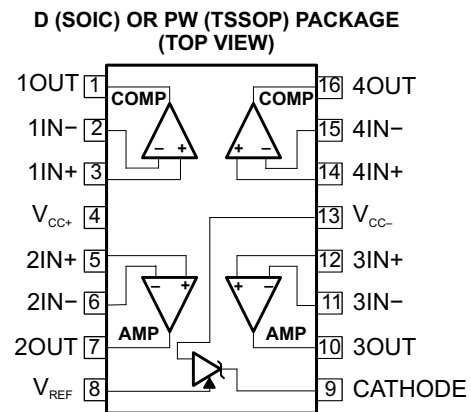

DESCRIPTION/ORDERING INFORMATION

The TSM102 and TSM102A combine the building blocks of a dual operational amplifier, a dual comparator, and a precision voltage reference, all of which often are used to implement a wide variety of power-management functions, including overcurrent detection, undervoltage/overvoltage detection, power-good detection, window comparators, error amplifiers, etc. Additional applications include alarm and detector/sensor applications.

The TSM102A offers a tight V_{REF} tolerance of 0.4% at 25°C. The TSM102 and TSM102A are characterized for operation from –40°C to 85°C.

ORDERING INFORMATION

T_A	MAX V_{REF} TOLERANCE (25°C)	PACKAGE ⁽¹⁾		ORDERABLE PART NUMBER	TOP-SIDE MARKING
–40°C to 85°C	A grade: 0.4% precision	SOIC – D	Tube of 75	TSM102AID	TSM102AI
			Reel of 2500	TSM102AIDR	
		TSSOP – PW	Tube of 90	TSM102AIPW	SN102AI
			Reel of 2000	TSM102AIPWR	
	Standard grade: 1% precision	SOIC – D	Tube of 75	TSM102ID	TSM102I
			Reel of 2500	TSM102IDR	
TSSOP – PW		Tube of 90	TSM102IPW	SN102I	
		Reel of 2000	TSM102IPWR		

(1) Package drawings, standard packing quantities, thermal data, symbolization, and PCB design guidelines are available at www.ti.com/sc/package.



Please be aware that an important notice concerning availability, standard warranty, and use in critical applications of Texas Instruments semiconductor products and disclaimers thereto appears at the end of this data sheet.

TSM102, TSM102A DUAL OPERATIONAL AMPLIFIER, DUAL COMPARATOR, AND VOLTAGE REFERENCE

SLVS602–MARCH 2006

Absolute Maximum Ratings⁽¹⁾

over free-air temperature range (unless otherwise noted)

		MIN	MAX	UNIT
V_{CC}	Supply voltage		36	V
V_{ID}	Input differential voltage		36	V
V_I	Input voltage range	-0.3	36	V
I_{KA}	Voltage reference cathode current		100	mA
θ_{JA}	Package thermal impedance ⁽²⁾⁽³⁾	D package	73	°C/W
		PW package	108	
T_J	Maximum junction temperature		150	°C
T_{stg}	Storage temperature range	-65	150	°C

- (1) Stresses beyond those listed under *Absolute Maximum Ratings* may cause permanent damage to the device. These are stress ratings only, and functional operation of the device at these or any other conditions beyond those indicated under *Recommended Operating Conditions* is not implied. Exposure to absolute-maximum-rated conditions for extended periods may affect device reliability.
- (2) Maximum power dissipation is a function of $T_J(\text{max})$, θ_{JA} , and T_A . The maximum allowable power dissipation at any allowable ambient temperature is $P_D = (T_J(\text{max}) - T_A)/\theta_{JA}$. Selecting the maximum of 150°C can affect reliability.
- (3) The package thermal impedance is calculated in accordance with JESD 51-7.

Recommended Operating Conditions

		MIN	MAX	UNIT
$V_{CC+} - V_{CC-}$	Supply voltage	3	30	V
V_{ID}	Comparator differential input voltage		$V_{CC+} - V_{CC-}$	V
V_{KA}	Cathode-to-anode voltage	V_{REF}	36	V
I_K	Reference cathode current	1	100	mA
T_A	Operating free-air temperature	-40	85	°C

Total Device Electrical Characteristics

PARAMETER	TEST CONDITIONS	T_A			UNIT	
		MIN	TYP	MAX		
I_{CC}	Total supply current, excluding reference cathode current	$V_{CC+} = 5\text{ V}$, $V_{CC-} = 0\text{ V}$, No load	25°C	0.8	1.5	mA
			Full range		2	

Operational Amplifier Electrical Characteristics
 $V_{CC+} = 5\text{ V}$, $V_{CC-} = \text{GND}$, R_1 connected to $V_{CC-}/2$ (unless otherwise noted)

PARAMETER		TEST CONDITIONS	T_A	MIN	TYP	MAX	UNIT
V_{IO}	Input offset voltage		25°C		1	4.5	mV
			Full range			6.5	
αV_{IO}	Input offset voltage drift		25°C		10		$\mu\text{V}/^\circ\text{C}$
I_{IO}	Input offset current		25°C		5	20	nA
			Full range			40	
I_{IB}	Input bias current		25°C		20	100	nA
			Full range			200	
A_{VD}	Large-signal voltage gain	$V_{CC+} = 30\text{ V}$, $R_1 = 10\text{ k}\Omega$, $V_O = 5\text{ V to }25\text{ V}$	25°C	50	100		V/mV
			Full range		25		
k_{SVR}	Supply-voltage rejection ratio	$V_{CC+} = 5\text{ V to }30\text{ V}$	25°C	80	100		dB
V_{ICM}	Input common-mode voltage		25°C	V_{CC-}		$V_{CC+} - 1.8$	V
			Full range	V_{CC-}		$V_{CC+} - 2.2$	
CMRR	Common-mode rejection ratio	$V_{CC+} = 30\text{ V}$, $V_{ICM} = 0\text{ V to }V_{CC+} - 1.8\text{ V}$	25°C	70	90		dB
I_{SC}	Short-circuit current	$V_{ID} = \pm 1\text{ V}$, $V_O = 2.5\text{ V}$	25°C	Source	3	6	mA
				Sink	3	6	
V_{OH}	High-level output voltage	$V_{CC+} = 30\text{ V}$, $R_L = 10\text{ k}\Omega$	25°C	27	28		V
			Full range		26		
V_{OL}	Low-level output voltage	$R_L = 10\text{ k}\Omega$	25°C		130	170	mV
			Full range			200	
SR	Slew rate	$V_{CC} = \pm 15\text{ V}$, $C_L = 100\text{ pF}$, $V_I = \pm 10\text{ V}$, $R_L = 10\text{ k}\Omega$	25°C	1.3	2		V/ μs
GBW	Gain bandwidth product	$R_L = 10\text{ k}\Omega$, $C_L = 100\text{ pF}$, $f = 100\text{ kHz}$	25°C	1.4	2.1		MHz
Φ_m	Phase margin	$R_L = 10\text{ k}\Omega$, $C_L = 100\text{ pF}$	25°C		45		°
THD	Total harmonic distortion		25°C		0.01		%
V_n	Equivalent input noise voltage	$f = 1\text{ kHz}$	25°C		19		nV/ $\sqrt{\text{Hz}}$

TSM102, TSM102A DUAL OPERATIONAL AMPLIFIER, DUAL COMPARATOR, AND VOLTAGE REFERENCE

SLVS602–MARCH 2006

Comparator Electrical Characteristics

$V_{CC+} = 5\text{ V}$, $V_{CC-} = \text{GND}$ (unless otherwise noted)

PARAMETER	TEST CONDITIONS	T_A	MIN	TYP	MAX	UNIT
V_{IO}	Input offset voltage	25°C			5	mV
		Full range			9	
V_{ID}	Comparator differential input voltage	Full range			V_{CC+}	V
I_{IO}	Input offset current	25°C			50	nA
		Full range			150	
I_{IB}	Input bias current	25°C			250	nA
		Full range			400	
I_{OH}	High-level output current	$V_{ID} = 1\text{ V}$, $V_{CC} = V_O = 30\text{ V}$		0.1		nA
		Full range			1	μA
V_{OL}	Low-level output voltage	$V_{ID} = -1\text{ V}$, $I_{\text{sink}} = 4\text{ mA}$		250	400	mV
		Full range			700	
A_{VD}	Large-signal voltage gain	$V_{CC+} = 15\text{ V}$, $R_1 = 15\text{ k}\Omega$, $V_O = 1\text{ V to }11\text{ V}$		200		V/mV
I_{sink}	Output sink current	$V_O = 1.5\text{ V}$, $V_{ID} = -1\text{ V}$	25°C	6	16	mA
V_{ICM}	Input common-mode voltage range		25°C	0	$V_{CC+} - 1.5$	V
			Full range	0	$V_{CC+} - 2$	
t_{RESP}	Response time ⁽¹⁾	$R_1 = 5.1\text{ k}\Omega$ to V_{CC+} , $V_{\text{REF}} = 1.4\text{ V}$	25°C		1.3	μs
$t_{\text{RESP,large}}$	Large-signal response time	$R_1 = 5.1\text{ k}\Omega$ to V_{CC+} , $V_{\text{REF}} = 1.4\text{ V}$, $V_I = \text{TTL}$	25°C		300	ns

(1) The response-time specification is for 100-mV input step with 5-mV overdrive. For larger overdrive signals, 300 ns can be obtained.

Voltage-Reference Electrical Characteristics

PARAMETER		TEST CONDITIONS	T _A	MIN	TYP	MAX	UNIT
V _{REF}	Reference voltage ⁽¹⁾	V _{KA} = V _{REF} , I _K = 10 mA, See Figure 1	25°C	2.475	2.5	2.525	V
			25°C	2.49	2.5	2.51	
ΔV _{REF}	Reference input voltage deviation over temperature range ⁽¹⁾	V _{KA} = V _{REF} , I _K = 10 mA, See Figure 1	Full range		7	30	mV
$\frac{V_{REF}}{T}$	Average temperature coefficient of reference input voltage ⁽²⁾	V _{KA} = V _{REF} , I _K = 10 mA	Full range		±22	±100	ppm/°C
$\frac{V_{REF}}{V_{KA}}$	Ratio of change in reference voltage to change in cathode voltage	V _{KA} = 3 V to 36 V, I _K = 10 mA, See Figure 2	25°C		-1.1	-2	mV/V
I _{REF}	Reference input current	I _K = 10 mA, R ₁ = 10 kΩ, R ₂ = ∞, See Figure 2	25°C		1.5	2.5	μA
			Full range			3	
ΔI _{REF}	Reference input current deviation over temperature range	I _K = 10 mA, R ₁ = 10 kΩ, R ₂ = ∞, See Figure 2	Full range		0.5	1	μA
I _{min}	Minimum cathode current for regulation	V _{KA} = V _{REF} , See Figure 1	25°C		0.5	1	mA
I _{K,OFF}	Off-state cathode current	See Figure 3	25°C		180	500	nA

(1) ΔV_{REF} is defined as the difference between the maximum and minimum values obtained over the full temperature range.

$$\Delta V_{REF} = V_{REF(MAX)} - V_{REF(MIN)}$$

(2) The temperature coefficient is defined as the slopes (positive and negative) of the voltage vs temperature limits within which the reference voltage is specified.

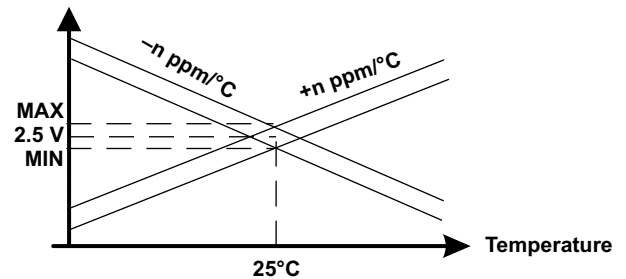
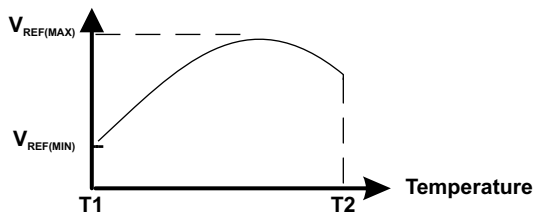

PARAMETER MEASUREMENT INFORMATION

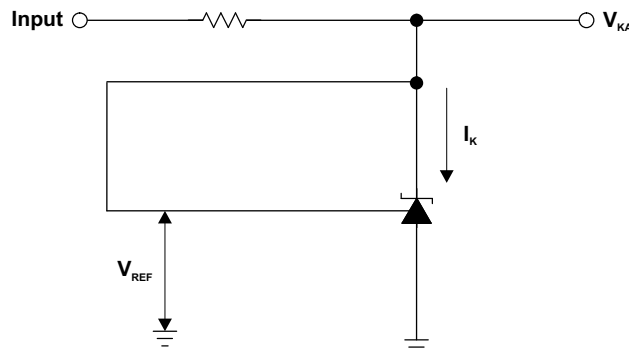

Figure 1. Test Circuit for $V_{KA} = V_{REF}$

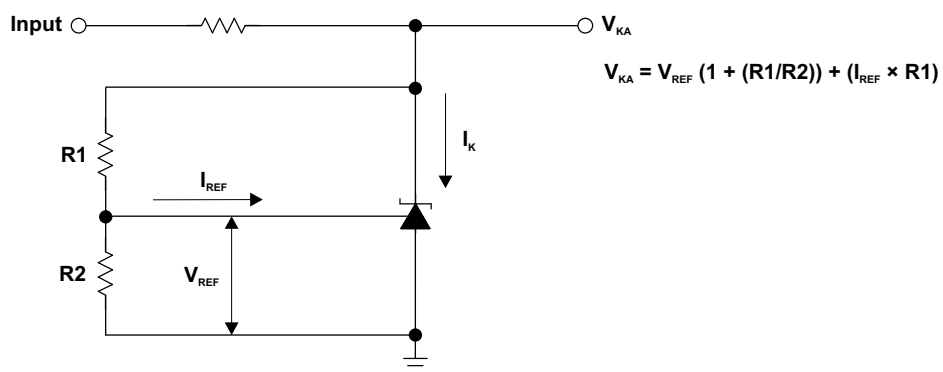

Figure 2. Test Circuit for $V_{KA} > V_{REF}$

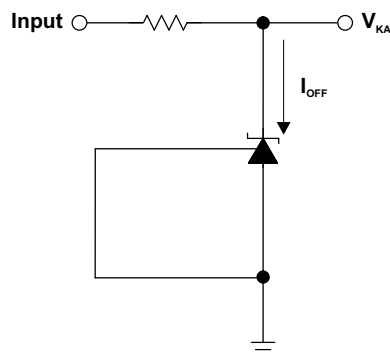

Figure 3. Test Circuit for I_{OFF}

TYPICAL CHARACTERISTICS

**AMPLIFIER TOTAL HARMONIC DISTORTION
VS
FREQUENCY**

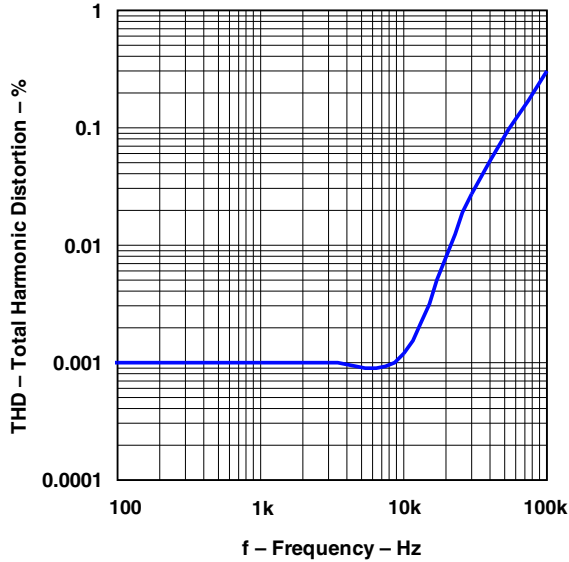

Figure 4.

**AMPLIFIER NOISE VOLTAGE
VS
FREQUENCY**

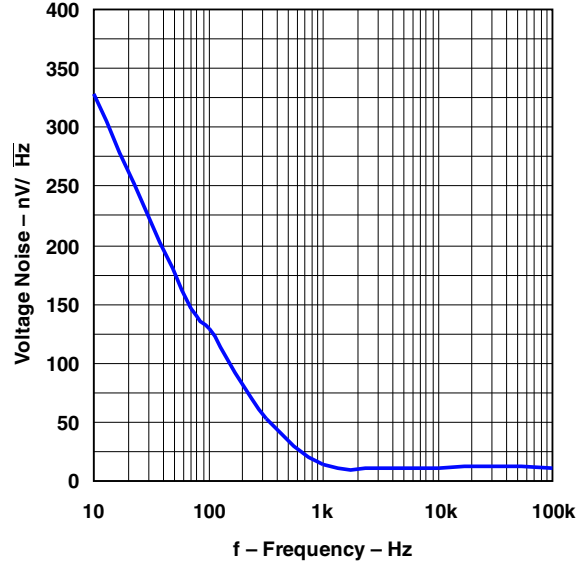

Figure 5.

**GAIN AND PHASE
VS
FREQUENCY**

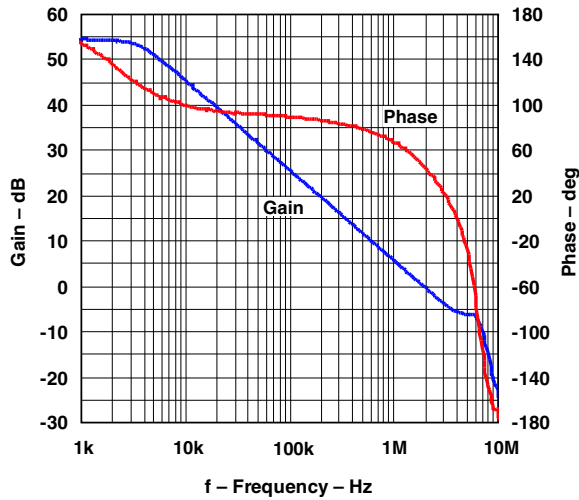

Figure 6.

**V_{REF} STABILITY
VS
CAPACITANCE**

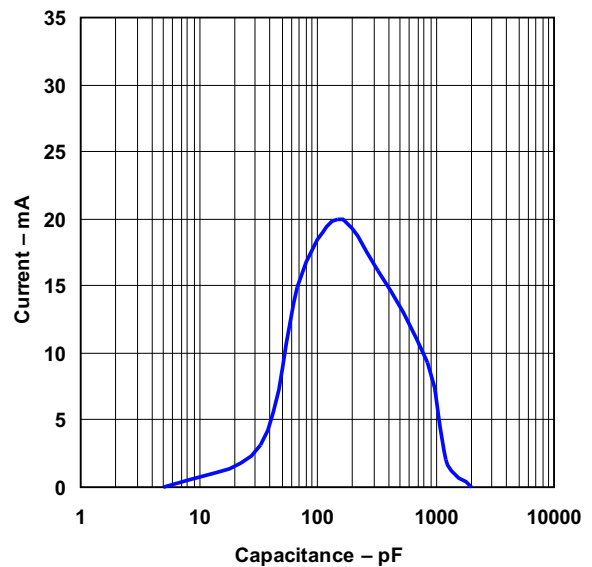

Figure 7.

TYPICAL CHARACTERISTICS (continued)

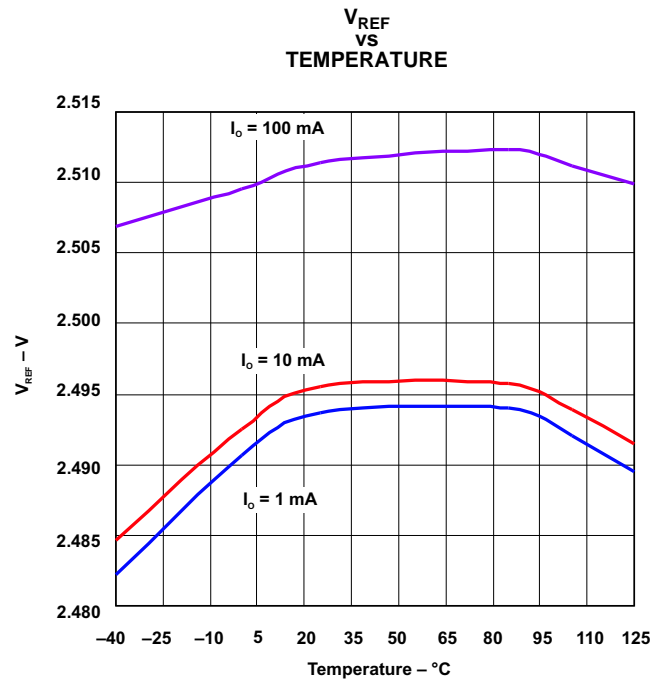

Figure 8.

PACKAGING INFORMATION

Orderable Device	Status (1)	Package Type	Package Drawing	Pins	Package Qty	Eco Plan (2)	Lead finish/ Ball material (6)	MSL Peak Temp (3)	Op Temp (°C)	Device Marking (4/5)	Samples
TSM102AIDR	ACTIVE	SOIC	D	16	2500	RoHS & Green	NIPDAU	Level-1-260C-UNLIM	-40 to 85	TSM102AI	Samples
TSM102AIPW	ACTIVE	TSSOP	PW	16	90	RoHS & Green	NIPDAU	Level-1-260C-UNLIM	-40 to 85	SN102AI	Samples
TSM102AIPWR	ACTIVE	TSSOP	PW	16	2000	RoHS & Green	NIPDAU	Level-1-260C-UNLIM	-40 to 85	SN102AI	Samples
TSM102ID	ACTIVE	SOIC	D	16	40	RoHS & Green	NIPDAU	Level-1-260C-UNLIM	-40 to 85	TSM102I	Samples
TSM102IDR	ACTIVE	SOIC	D	16	2500	RoHS & Green	NIPDAU	Level-1-260C-UNLIM	-40 to 85	TSM102I	Samples
TSM102IPWR	ACTIVE	TSSOP	PW	16	2000	RoHS & Green	NIPDAU	Level-1-260C-UNLIM	-40 to 85	SN102I	Samples

(1) The marketing status values are defined as follows:

ACTIVE: Product device recommended for new designs.

LIFEBUY: TI has announced that the device will be discontinued, and a lifetime-buy period is in effect.

NRND: Not recommended for new designs. Device is in production to support existing customers, but TI does not recommend using this part in a new design.

PREVIEW: Device has been announced but is not in production. Samples may or may not be available.

OBSELETE: TI has discontinued the production of the device.

(2) **RoHS:** TI defines "RoHS" to mean semiconductor products that are compliant with the current EU RoHS requirements for all 10 RoHS substances, including the requirement that RoHS substance do not exceed 0.1% by weight in homogeneous materials. Where designed to be soldered at high temperatures, "RoHS" products are suitable for use in specified lead-free processes. TI may reference these types of products as "Pb-Free".

RoHS Exempt: TI defines "RoHS Exempt" to mean products that contain lead but are compliant with EU RoHS pursuant to a specific EU RoHS exemption.

Green: TI defines "Green" to mean the content of Chlorine (Cl) and Bromine (Br) based flame retardants meet JS709B low halogen requirements of <=1000ppm threshold. Antimony trioxide based flame retardants must also meet the <=1000ppm threshold requirement.

(3) MSL, Peak Temp. - The Moisture Sensitivity Level rating according to the JEDEC industry standard classifications, and peak solder temperature.

(4) There may be additional marking, which relates to the logo, the lot trace code information, or the environmental category on the device.

(5) Multiple Device Markings will be inside parentheses. Only one Device Marking contained in parentheses and separated by a "-" will appear on a device. If a line is indented then it is a continuation of the previous line and the two combined represent the entire Device Marking for that device.

(6) Lead finish/Ball material - Orderable Devices may have multiple material finish options. Finish options are separated by a vertical ruled line. Lead finish/Ball material values may wrap to two lines if the finish value exceeds the maximum column width.

Important Information and Disclaimer: The information provided on this page represents TI's knowledge and belief as of the date that it is provided. TI bases its knowledge and belief on information provided by third parties, and makes no representation or warranty as to the accuracy of such information. Efforts are underway to better integrate information from third parties. TI has taken and continues to take reasonable steps to provide representative and accurate information but may not have conducted destructive testing or chemical analysis on incoming materials and chemicals. TI and TI suppliers consider certain information to be proprietary, and thus CAS numbers and other limited information may not be available for release.

In no event shall TI's liability arising out of such information exceed the total purchase price of the TI part(s) at issue in this document sold by TI to Customer on an annual basis.

TAPE AND REEL INFORMATION

QUADRANT ASSIGNMENTS FOR PIN 1 ORIENTATION IN TAPE

*All dimensions are nominal

Device	Package Type	Package Drawing	Pins	SPQ	Reel Diameter (mm)	Reel Width W1 (mm)	A0 (mm)	B0 (mm)	K0 (mm)	P1 (mm)	W (mm)	Pin1 Quadrant
TSM102AIDR	SOIC	D	16	2500	330.0	16.4	6.5	10.3	2.1	8.0	16.0	Q1
TSM102AIPWR	TSSOP	PW	16	2000	330.0	12.4	6.9	5.6	1.6	8.0	12.0	Q1
TSM102IDR	SOIC	D	16	2500	330.0	16.4	6.5	10.3	2.1	8.0	16.0	Q1
TSM102IPWR	TSSOP	PW	16	2000	330.0	12.4	6.9	5.6	1.6	8.0	12.0	Q1

TAPE AND REEL BOX DIMENSIONS

*All dimensions are nominal

Device	Package Type	Package Drawing	Pins	SPQ	Length (mm)	Width (mm)	Height (mm)
TSM102AIDR	SOIC	D	16	2500	356.0	356.0	35.0
TSM102AIPWR	TSSOP	PW	16	2000	356.0	356.0	35.0
TSM102IDR	SOIC	D	16	2500	356.0	356.0	35.0
TSM102IPWR	TSSOP	PW	16	2000	356.0	356.0	35.0

TUBE

*All dimensions are nominal

Device	Package Name	Package Type	Pins	SPQ	L (mm)	W (mm)	T (μm)	B (mm)
TSM102AIPW	PW	TSSOP	16	90	530	10.2	3600	3.5
TSM102ID	D	SOIC	16	40	506.6	8	3940	4.32

D (R-PDSO-G16)

PLASTIC SMALL OUTLINE



- NOTES:
- A. All linear dimensions are in inches (millimeters).
 - B. This drawing is subject to change without notice.
 - C. Body length does not include mold flash, protrusions, or gate burrs. Mold flash, protrusions, or gate burrs shall not exceed 0.006 (0,15) each side.
 - D. Body width does not include interlead flash. Interlead flash shall not exceed 0.017 (0,43) each side.
 - E. Reference JEDEC MS-012 variation AC.



4220204/A 02/2017

NOTES:

1. All linear dimensions are in millimeters. Any dimensions in parenthesis are for reference only. Dimensioning and tolerancing per ASME Y14.5M.
2. This drawing is subject to change without notice.
3. This dimension does not include mold flash, protrusions, or gate burrs. Mold flash, protrusions, or gate burrs shall not exceed 0.15 mm per side.
4. This dimension does not include interlead flash. Interlead flash shall not exceed 0.25 mm per side.
5. Reference JEDEC registration MO-153.

EXAMPLE BOARD LAYOUT

PW0016A

TSSOP - 1.2 mm max height

SMALL OUTLINE PACKAGE



LAND PATTERN EXAMPLE
EXPOSED METAL SHOWN
SCALE: 10X



SOLDER MASK DETAILS

4220204/A 02/2017

NOTES: (continued)

- 6. Publication IPC-7351 may have alternate designs.
- 7. Solder mask tolerances between and around signal pads can vary based on board fabrication site.

EXAMPLE STENCIL DESIGN

PW0016A

TSSOP - 1.2 mm max height

SMALL OUTLINE PACKAGE



SOLDER PASTE EXAMPLE
BASED ON 0.125 mm THICK STENCIL
SCALE: 10X

4220204/A 02/2017

NOTES: (continued)

8. Laser cutting apertures with trapezoidal walls and rounded corners may offer better paste release. IPC-7525 may have alternate design recommendations.
9. Board assembly site may have different recommendations for stencil design.

IMPORTANT NOTICE AND DISCLAIMER

TI PROVIDES TECHNICAL AND RELIABILITY DATA (INCLUDING DATA SHEETS), DESIGN RESOURCES (INCLUDING REFERENCE DESIGNS), APPLICATION OR OTHER DESIGN ADVICE, WEB TOOLS, SAFETY INFORMATION, AND OTHER RESOURCES "AS IS" AND WITH ALL FAULTS, AND DISCLAIMS ALL WARRANTIES, EXPRESS AND IMPLIED, INCLUDING WITHOUT LIMITATION ANY IMPLIED WARRANTIES OF MERCHANTABILITY, FITNESS FOR A PARTICULAR PURPOSE OR NON-INFRINGEMENT OF THIRD PARTY INTELLECTUAL PROPERTY RIGHTS.

These resources are intended for skilled developers designing with TI products. You are solely responsible for (1) selecting the appropriate TI products for your application, (2) designing, validating and testing your application, and (3) ensuring your application meets applicable standards, and any other safety, security, regulatory or other requirements.

These resources are subject to change without notice. TI grants you permission to use these resources only for development of an application that uses the TI products described in the resource. Other reproduction and display of these resources is prohibited. No license is granted to any other TI intellectual property right or to any third party intellectual property right. TI disclaims responsibility for, and you will fully indemnify TI and its representatives against, any claims, damages, costs, losses, and liabilities arising out of your use of these resources.

TI's products are provided subject to [TI's Terms of Sale](#) or other applicable terms available either on [ti.com](https://www.ti.com) or provided in conjunction with such TI products. TI's provision of these resources does not expand or otherwise alter TI's applicable warranties or warranty disclaimers for TI products.

TI objects to and rejects any additional or different terms you may have proposed.

Mailing Address: Texas Instruments, Post Office Box 655303, Dallas, Texas 75265
Copyright © 2024, Texas Instruments Incorporated

Looking for pricing, stock, or lifecycle information?

Click below to explore more details on WIN SOURCE:

 [View TSM102AIPWRG4](#) on WIN SOURCE

 [Texas Instruments](#) Information

Optimize Your Supply Chain with WIN SOURCE Solutions

-  Global Sourcing Solution
-  Obsolete Management
-  Cost Control Management
-  Shortage Management
-  Alternative Solution
-  Excess Inventory Management