



THE DATASHEET OF AD6624AS





Four-Channel, 100 MSPS Digital Receive Signal Processor (RSP)

AD6624A

FEATURES

- 100 MSPS Wideband Inputs (14 Linear Bits Plus 3 RSSI)
- Dual High-Speed Data Input Ports
- Four Independent Digital Receivers in Single Package
- Digital Resampling for Noninteger Decimation Rates
- Programmable Decimating FIR Filters
- Programmable Attenuator Control for Clip Prevention and External Gain Ranging via Level Indicator
- Flexible Control for Multicarrier and Phased Array
- 3.3 V I/O, 2.5 V CMOS Core
- User-Configurable Built-In Self-Test (BIST) Capability
- JTAG Boundary Scan

APPLICATIONS

- Multicarrier, Multimode Digital Receivers GSM, IS136, EDGE, PHS, IS95
- Micro and Pico Cell Systems
- Wireless Local Loop
- Smart Antenna Systems
- Software Radios
- In-Building Wireless Telephony

PRODUCT DESCRIPTION

The AD6624A is a four-channel (quad) digital receive signal processor (RSP) with four cascaded signal-processing elements: a frequency translator, two fixed-coefficient decimating filters, and a programmable-coefficient decimating filter.

The AD6624A is part of Analog Devices' SoftCell® multicarrier transceiver chipset designed for compatibility with Analog Devices' family of high sample rate IF sampling ADCs (AD6640/AD6644 12- and 14-bit). The SoftCell receiver comprises a digital receiver capable of digitizing an entire spectrum of carriers and digitally selecting the carrier of interest for tuning and channel selection. This architecture eliminates redundant radios in wireless base station applications.

High dynamic range decimation filters offer a wide range of decimation rates. The RAM-based architecture allows easy reconfiguration for multimode applications.

The decimating filters remove unwanted signals and noise from the channel of interest. When the channel of interest occupies less bandwidth than the input signal, this rejection of out-of-band noise is called "processing gain." By using large decimation factors, this "processing gain" can improve the SNR of the ADC by 30 dB or more. In addition, the programmable RAM coefficient filter allows antialiasing, matched filtering, and static equalization functions to be combined in a single, cost-effective filter.

The AD6624A is compatible with standard ADC converters such as the AD664x, AD9042, AD943x and the AD922x families of data converters. The AD6624A is also compatible with the AD6600 Diversity ADC, providing a cost and size reduction path.

FUNCTIONAL BLOCK DIAGRAM

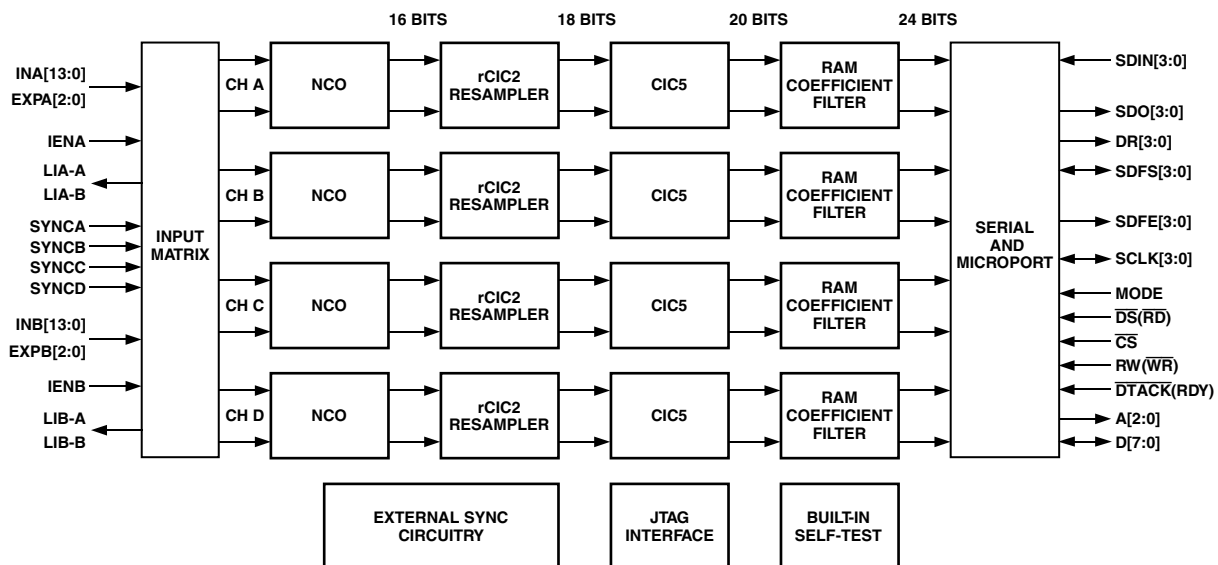

SoftCell is a registered trademark of Analog Devices, Inc.

REV. 0

Information furnished by Analog Devices is believed to be accurate and reliable. However, no responsibility is assumed by Analog Devices for its use, nor for any infringements of patents or other rights of third parties that may result from its use. No license is granted by implication or otherwise under any patent or patent rights of Analog Devices.

One Technology Way, P.O. Box 9106, Norwood, MA 02062-9106, U.S.A.
 Tel: 781/329-4700 www.analog.com
 Fax: 781/326-8703 © Analog Devices, Inc., 2002

AD6624A

TABLE OF CONTENTS

FEATURES	1	Serial Ports Cascaded	26
GENERAL DESCRIPTION	1	Serial Output Frame Timing (Master and Slave)	26
FUNCTIONAL BLOCK DIAGRAM	1	Serial Port Timing Specifications	28
SPECIFICATIONS/CHARACTERISTICS	3	SBM0	29
TIMING DIAGRAMS	6	SCLK	29
ABSOLUTE MAXIMUM RATINGS	9	SDIN	29
PIN FUNCTION DESCRIPTIONS	11	SDO	29
ARCHITECTURE	13	SDFS	29
EXAMPLE FILTER RESPONSE	14	SDFE	29
INPUT DATA PORTS	14	Serial Word Length	29
Input Data Format	14	SDFS Mode	29
Input Timing	14	Mapping RCF Data to the BIST Registers	30
Input Enable Control	14	0x00–0x7F: Coefficient Memory (CMEM)	30
Gain Switching	15	0x80: Channel Sleep Register	30
Input Data Scaling	16	0x81: Soft_SYNC Register	30
Scaling with Fixed-Point ADCs	16	0x82: Pin_SYNC Register	30
Scaling with Floating-Point or Gain-Ranging ADCs	16	0x83: Start Hold-Off Counter	30
NUMERICALLY CONTROLLED OSCILLATOR	17	0x84: NCO Frequency Hold-Off Counter	30
Frequency Translation	17	0x85: NCO Frequency Register 0	30
NCO Frequency Hold-Off Register	17	0x86: NCO Frequency Register 1	30
Phase Offset	17	0x87: NCO Phase Offset Register	30
NCO Control Register	17	0x88: NCO Control Register	30
Bypass	17	0x90: rCIC2 Decimation – 1 ($M_{rCIC2-1}$)	31
Phase Dither	17	0x91: rCIC2 Interpolation – 1 ($L_{rCIC2-1}$)	31
Amplitude Dither	17	0x92: rCIC2 Scale	31
Clear Phase Accumulator on HOP	17	0x93:	31
Input Enable Control	17	0x94: CIC5 Decimation – 1 (M_{CIC5-1})	31
Mode 00: Blank On IEN Low	17	0x95: CIC5 Scale	31
Mode 01: Clock On IEN High	18	0x96:	31
Mode 10: Clock on IEN Transition to High	18	0xA0: RCF Decimation – 1 (M_{RCF-1})	31
Mode 11: Clock on IEN Transition to Low	18	0xA1: RCF Decimation Phase (P_{RCF})	31
WB Input Select	18	0xA2: RCF Number of Taps Minus One (N_{RCF-1})	31
Sync Select	18	0xA3: RCF Coefficient Offset (CO_{RCF})	31
SECOND ORDER rCIC FILTER	18	0xA4: RCF Control Register	31
rCIC2 Rejection	19	0xA5: BIST Register for I	32
Example Calculations	19	0xA6: BIST Register for Q	32
Decimation and Interpolation Registers	19	0xA7: BIST Control Register	32
rCIC2 Scale	19	0xA8: RAM BIST Control Register	32
FIFTH ORDER CASCADED INTEGRATOR COMB FILTER	20	0xA9: Serial Port Control Register	32
CIC5 Rejection	20	MICROPORT CONTROL	33
RAM COEFFICIENT FILTER	20	External Memory Map	33
RCF Decimation Register	21	Access Control Register (ACR)	33
RCF Decimation Phase	21	External Memory Map	34
RCF Filter Length	21	Channel Address Register (CAR)	34
RCF Output Scale Factor and Control Register	21	SOFT_SYNC Control Register	34
USER-CONFIGURABLE BUILT-IN SELF-TEST (BIST)	22	PIN_SYNC Control Register	34
RAM BIST	22	SLEEP Control Register	34
CHANNEL BIST	22	Data Address Registers	35
CHIP SYNCHRONIZATION	22	Write Sequencing	35
Start	23	Read Sequencing	35
Hop	23	Read/Write Chaining	35
SERIAL OUTPUT DATA PORT	24	Intel Nonmultiplexed Mode (INM)	35
Serial Output Data Format	24	Motorola Nonmultiplexed Mode (MNM)	35
Compact Serial Data Format	24	Input Port Control Registers	35
Serial Data Frame (Serial Bus Master)	24	SERIAL PORT CONTROL	36
Serial Data Frame (Serial Cascade)	25	JTAG BOUNDARY SCAN	36
Configuring the Serial Ports	25	INTERNAL WRITE ACCESS	37
Serial Port Data Rate	25	Write Pseudocode	37
Serial Port to DSP Interconnection	25	INTERNAL READ ACCESS	38
Serial Slave Operation	26	Read Pseudocode	38
		OUTLINE DIMENSIONS	39

SPECIFICATIONS

(VDD = 2.5 V ± 5%, VDDIO = 3.3 V ± 10%. All specifications TA = TMIN to TMAX, unless otherwise noted.)

RECOMMENDED OPERATING CONDITIONS

Parameter	Test Level	AD6624AS			Unit
		Min	Typ	Max	
VDD	IV	2.375	2.5	2.675	V
VDDIO	IV	3.0	3.3	3.6	V
TAMBIENT	IV	-40	+25	+70	°C

ELECTRICAL CHARACTERISTICS

Parameter (Conditions)	Temp	Test Level	Min	AD6624AS Typ	Max	Unit
LOGIC INPUTS (5 V TOLERANT)						
Logic Compatibility	Full			3.3 V CMOS		
Logic "1" Voltage	Full	IV	2.0		5.0	V
Logic "0" Voltage	Full	IV	-0.3		+0.8	V
Logic "1" Current	Full	IV		1	10	μA
Logic "0" Current	Full	IV		1	10	μA
Input Capacitance	25°C	V		4		pF
LOGIC OUTPUTS						
Logic Compatibility	Full			3.3 V CMOS/TTL		
Logic "1" Voltage (IOH = 0.25 mA)	Full	IV	2.4	VDD - 0.2		V
Logic "0" Voltage (IOL = 0.25 mA)	Full	IV		0.2	0.4	V
IDD SUPPLY CURRENT						
CLK = 100 MHz, (VDD = 2.75 V, VDDIO = 3.6 V)	Full	IV				
I _{VDD}				545		mA
I _{VDDIO}				60		mA
CLK = GSM Example (65 MSPS, VDD = 2.5 V, VDDIO = 3.3 V, Dec = 2/10/6 120 Taps 4 Channels)	25°C	V				
I _{VDD}				250		mA
I _{VDDIO}				24		mA
POWER DISSIPATION						
CLK = 80 MHz TD-SCDMA	Full	IV		1.1		W
CLK = 65 MHz GSM/EDGE Example		V		700		mW
Sleep Mode	Full	IV		287		μW

Specifications subject to change without notice.

AD6624A

GENERAL TIMING CHARACTERISTICS^{1, 2}

Parameter (Conditions)	Temp	Test Level	AD6624AS			Unit
			Min	Typ	Max	
<i>CLK Timing Requirements:</i>						
t _{CLK} CLK Period	Full	I	10			ns
t _{CLKL} CLK Width Low	Full	IV	4.5	0.5 × t _{CLK}		ns
t _{CLKH} CLK Width High	Full	IV	4.5	0.5 × t _{CLK}		ns
<i>RESET Timing Requirement:</i>						
t _{RESL} RESET Width Low	Full	I	30.0			ns
<i>Input Wideband Data Timing Requirements:</i>						
t _{SI} Input to ↑CLK Setup Time	Full	IV	0.8			ns
t _{HI} Input to ↑CLK Hold Time	Full	IV	2.0			ns
<i>Level Indicator Output Switching Characteristic:</i>						
t _{DLI} ↑CLK to LI (A–A, B; B–A, B) Output Delay Time	Full	IV	3.8		12.6	ns
<i>SYNC Timing Requirements:</i>						
t _{SS} SYNC (A, B, C, D) to ↑CLK Setup Time	Full	IV	1.0			ns
t _{HS} SYNC (A, B, C, D) to ↑CLK Hold Time	Full	IV	2.0			ns
<i>Serial Port Timing Requirements (SBM = 1):</i>						
<i>Switching Characteristics:³</i>						
t _{DSCLKI} ↑CLK to ↑SCLK Delay (Divide by 1)	Full	IV	3.9		13.4	ns
t _{DSCLKH} ↑CLK to ↑SCLK Delay (For Any Other Divisor)	Full	IV	4.4		14.0	ns
t _{DSCLKL} ↑CLK to ↓SCLK Delay (Divide by 2 or Even #)	Full	IV	3.25		6.7	ns
t _{DSCLKLL} ↓CLK to ↓SCLK Delay (Divide by 3 or Odd #)	Full	IV	3.8		6.9	ns
t _{DSDFS} ↑SCLK to SDFS Delay	Full	IV	0.2		5.3	ns
t _{DSDFE} ↑SCLK to SDFE Delay	Full	IV	-0.4		+4.7	ns
t _{DSDO} ↑SCLK to SDO Delay	Full	IV	-1.0		+4.0	ns
t _{DSDR} ↑SCLK to DR Delay	Full	IV	-0.3		+4.6	ns
t _{DDR} ↑CLK to DR Delay	Full	IV	5.4		17.6	ns
<i>Input Characteristics:</i>						
t _{SSI} SDI to ↓SCLK Setup Time	Full	IV	2.4			ns
t _{HSI} SDI to ↓SCLK Hold Time	Full	IV	3.0			ns
<i>Serial Port Timing Requirements (SBM = 0):</i>						
<i>Switching Characteristics:³</i>						
t _{SCLK} SCLK Period	Full	IV	16			ns
t _{SCLKL} SCLK Low Time (When SDIV = 1, Divide by 1)	Full	IV	5.0			ns
t _{SCLKH} SCLK High Time (When SDIV = 1, Divide by 1)	Full	IV	5.0			ns
t _{DSDFE} ↑SCLK to SDFE Delay	Full	IV	3.8		15.4	ns
t _{DSDO} ↑SCLK to SDO Delay	Full	IV	3.7		15.2	ns
t _{DSDR} ↑SCLK to DR Delay	Full	IV	3.9		15.9	ns
<i>Input Characteristics:</i>						
t _{SSF} SDFS to ↑SCLK Setup Time	Full	IV	1.9			ns
t _{HSF} SDFS to ↑SCLK Hold Time	Full	IV	0.7			ns
t _{SSI} SDI to ↓SCLK Setup Time	Full	IV	2.4			ns
t _{HSI} SDI to ↓SCLK Hold Time	Full	IV	2.0			ns

NOTES

¹All Timing Specifications valid over VDD range of 2.375 V to 2.675 V and VDDIO range of 3.0 V to 3.6 V.

²C_{LOAD} = 40 pF on all outputs unless otherwise specified.

³The timing parameters for SCLK, SDFS, SDFE, SDO, SDI, and DR apply to all four channels (0, 1, 2, and 3). The slave serial port's (SCLK) operating frequency is limited to 62.5 MHz.

Specifications subject to change without notice.

MICROPROCESSOR PORT TIMING CHARACTERISTICS^{1, 2}

Parameter (Conditions)	Temp	Test Level	AD6624AS			Unit
			Min	Typ	Max	
MICROPROCESSOR PORT, MODE INM (MODE = 0)						
<i>MODE INM Write Timing:</i>						
t _{SC}	Control ³ to ↑CLK Setup Time	Full	IV	5.5		ns
t _{HC}	Control ³ to ↑CLK Hold Time	Full	IV	1.0		ns
t _{HWR}	$\overline{WR}(RW)$ to RDY(\overline{DTACK}) Hold Time	Full	IV	8.0		ns
t _{SAM}	Address/Data to $\overline{WR}(RW)$ Setup Time	Full	IV	-0.5		ns
t _{HAM}	Address/Data to RDY(\overline{DTACK}) Hold Time	Full	IV	7.0		ns
t _{DRDY}	$\overline{WR}(RW)$ to RDY(\overline{DTACK}) Delay	Full	IV	4.0		ns
t _{ACC}	$\overline{WR}(RW)$ to RDY(\overline{DTACK}) High Delay	Full	IV	4 × t _{CLK}	5 × t _{CLK} 9 × t _{CLK}	ns
<i>MODE INM Read Timing:</i>						
t _{SC}	Control ³ to ↑CLK Setup Time	Full	IV	4.0		ns
t _{HC}	Control ³ to ↑CLK Hold Time	Full	IV	2.0		ns
t _{SAM}	Address to $\overline{RD}(\overline{DS})$ Setup Time	Full	IV	0.0		ns
t _{HAM}	Address to Data Hold Time	Full	IV	7.0		ns
t _{DRDY}	$\overline{RD}(\overline{DS})$ to RDY(\overline{DTACK}) Delay	Full	IV	4.0		ns
t _{ACC}	$\overline{RD}(\overline{DS})$ to RDY(\overline{DTACK}) High Delay	Full	IV	8 × t _{CLK}	10 × t _{CLK} 13 × t _{CLK}	ns
MICROPROCESSOR PORT, MODE MNM (MODE = 1)						
<i>MODE MNM Write Timing:</i>						
t _{SC}	Control ³ to ↑CLK Setup Time	Full	IV	5.5		ns
t _{HC}	Control ³ to ↑CLK Hold Time	Full	IV	1.0		ns
t _{HDS}	$\overline{DS}(\overline{RD})$ to $\overline{DTACK}(\overline{RDY})$ Hold Time	Full	IV	8.0		ns
t _{HRW}	$\overline{RW}(\overline{WR})$ to $\overline{DTACK}(\overline{RDY})$ Hold Time	Full	IV	8.0		ns
t _{SAM}	Address/Data to $\overline{RW}(\overline{WR})$ Setup Time	Full	IV	-0.5		ns
t _{HAM}	Address/Data to $\overline{RW}(\overline{WR})$ Hold Time	Full	IV	7.0		ns
t _{ACC}	$\overline{RW}(\overline{WR})$ to $\overline{DTACK}(\overline{RDY})$ Low Delay	Full	IV	4 × t _{CLK}	5 × t _{CLK} 9 × t _{CLK}	ns
<i>MODE MNM Read Timing:</i>						
t _{SC}	Control ³ to ↑CLK Setup Time	Full	IV	4.0		ns
t _{HC}	Control ³ to ↑CLK Hold Time	Full	IV	2.0		ns
t _{SAM}	Address to $\overline{DS}(\overline{RD})$ Setup Time	Full	IV	0.0		ns
t _{HAM}	Address to Data Hold Time	Full	IV	7.0		ns
t _{ZD}	Data Three-State Delay	Full	IV	7.0		ns
t _{ACC}	$\overline{DS}(\overline{RD})$ to $\overline{DTACK}(\overline{RDY})$ Low Delay	Full	IV	8 × t _{CLK}	10 × t _{CLK} 13 × t _{CLK}	ns

NOTES

¹All Timing Specifications valid over VDD range of 2.375 V to 2.675 V and VDDIO range of 3.0 V to 3.6 V.

²C_{LOAD} = 40 pF on all outputs unless otherwise specified.

³Specification pertains to control signals: \overline{RW} , \overline{WR} , \overline{DS} , \overline{RD} , \overline{CS} .

Specifications subject to change without notice.

AD6624A

TIMING DIAGRAMS

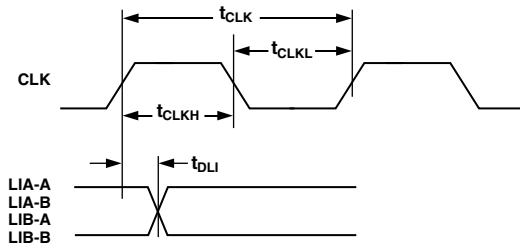

Figure 1. Level Indicator Output Switching Characteristics

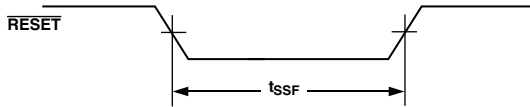

Figure 2. $\overline{\text{RESET}}$ Timing Requirements

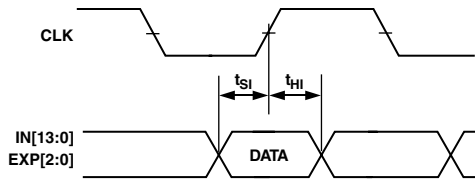

Figure 3. Input Data Timing Requirements

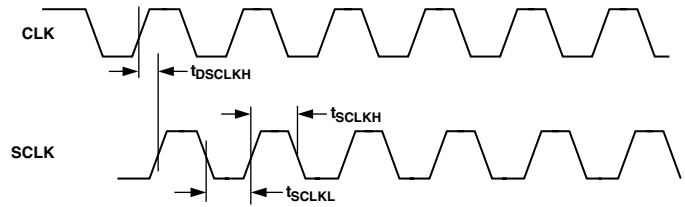

Figure 4. SCLK Switching Characteristics (Divide by 1)

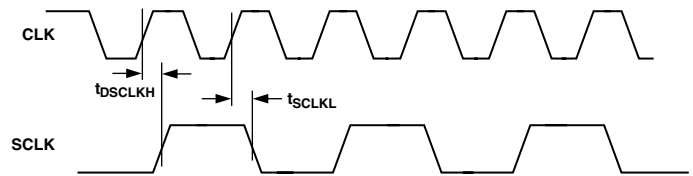

Figure 5. SCLK Switching Characteristic (Divide by 2 or EVEN Integer)

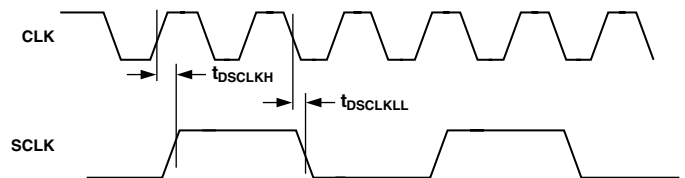

Figure 6. SCLK Switching Characteristic (Divide by 3 or ODD Integer)

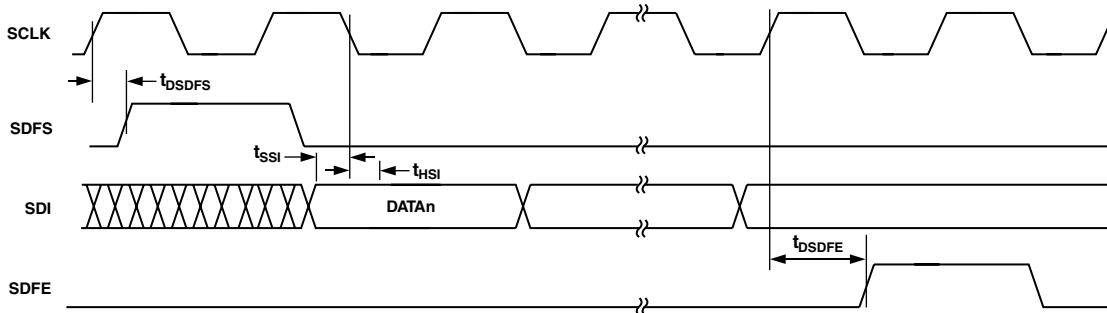

Figure 7. Serial Port Switching Characteristics

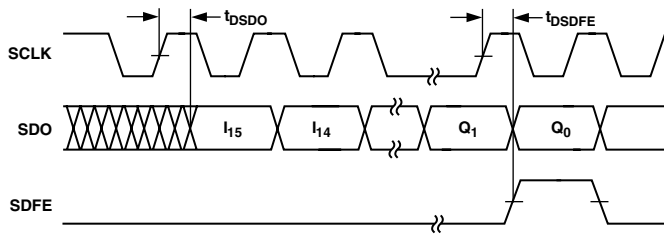

Figure 8. SDO, SDFE Switching Characteristics

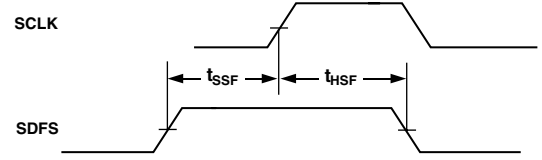

Figure 11. SDFS Timing Requirements (SBM = 0)

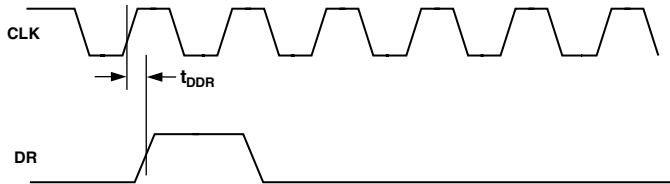

Figure 9. CLK, DR Switching Characteristics

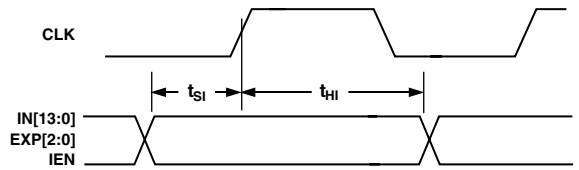

Figure 12. Input Timing for A and B Channels

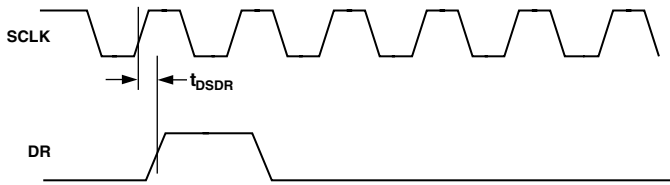

Figure 10. SCLK, DR Switching Characteristics

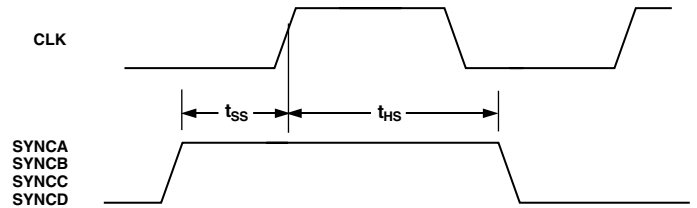
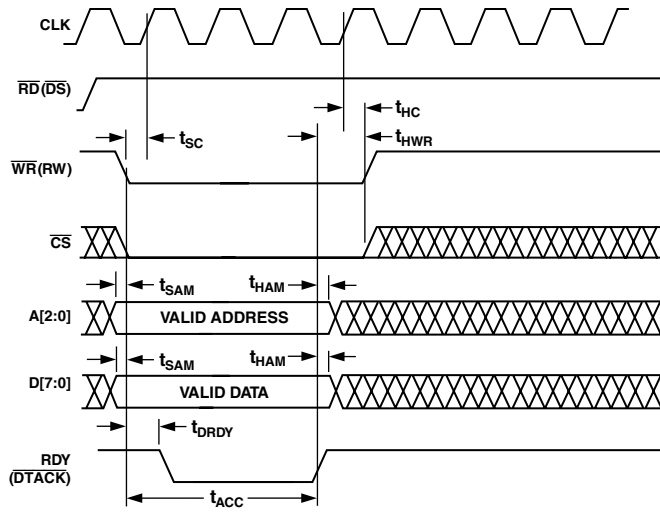

Figure 13. SYNC Timing Inputs

AD6624A

TIMING DIAGRAMS—INM MICROPORT MODE



- NOTES
1. t_{ACC} ACCESS TIME DEPENDS ON THE ADDRESS ACCESSED. ACCESS TIME IS MEASURED FROM FE OF \overline{WR} TO THE RE OF RDY.
 2. t_{ACC} REQUIRES A MAXIMUM 9 CLK PERIODS.

Figure 14. INM Microport Write Timing Requirements

TIMING DIAGRAMS—MNM MICROPORT MODE

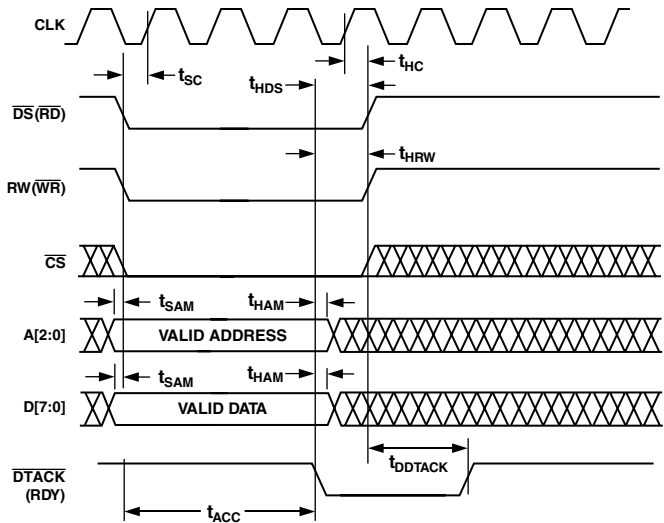

- NOTES
1. t_{ACC} ACCESS TIME DEPENDS ON THE ADDRESS ACCESSED. ACCESS TIME IS MEASURED FROM FE OF \overline{DS} TO THE FE OF \overline{DTACK} .
 2. t_{ACC} REQUIRES A MAXIMUM 9 CLK PERIODS.

Figure 16. MNM Microport Write Timing Requirements

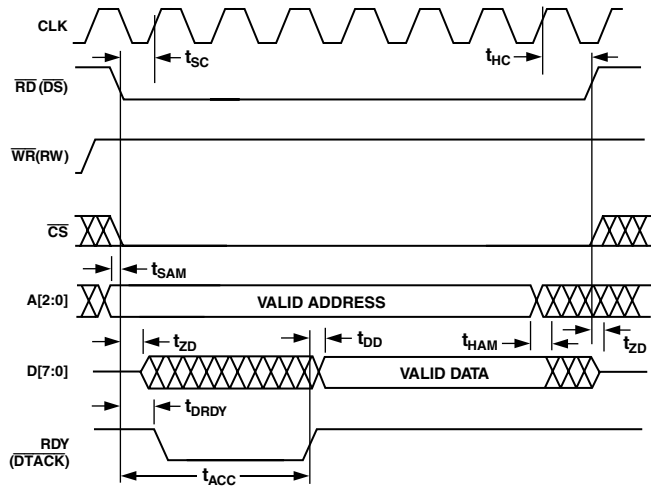

- NOTES
1. t_{ACC} ACCESS TIME DEPENDS ON THE ADDRESS ACCESSED. ACCESS TIME IS MEASURED FROM FE OF \overline{WR} TO THE RE OF RDY.
 2. t_{ACC} REQUIRES A MAXIMUM OF 13 CLK PERIODS AND APPLIES TO A[2:0] = 7, 6, 5, 3, 2, 1

Figure 15. INM Microport Read Timing Requirements

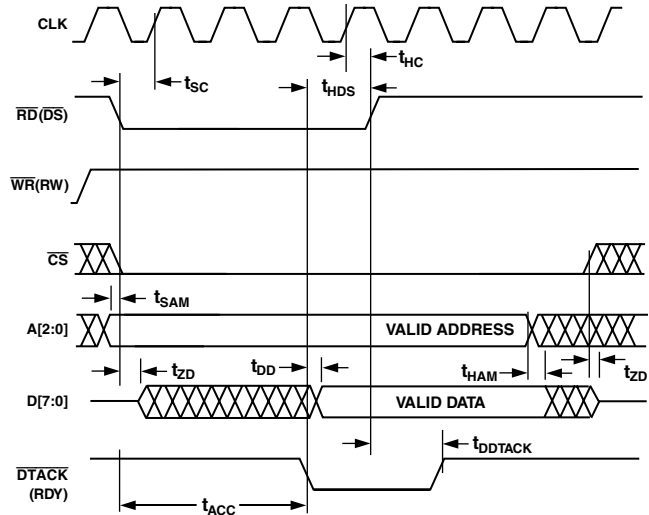

- NOTES
1. t_{ACC} ACCESS TIME DEPENDS ON THE ADDRESS ACCESSED. ACCESS TIME IS MEASURED FROM FE OF \overline{DS} TO THE FE OF \overline{DTACK} .
 2. t_{ACC} REQUIRES A MAXIMUM 13 CLK PERIODS.

Figure 17. MNM Microport Read Timing Requirements

ABSOLUTE MAXIMUM RATINGS*

Supply Voltage	3.6 V
Input Voltage	-0.3 V to +5.3 V (5 V Tolerant)
Output Voltage Swing	-0.3 V to VDDIO + 0.3 V
Load Capacitance	200 pF
Junction Temperature Under Bias	125°C
Storage Temperature Range	-65°C to +150°C
Lead Temperature (5 sec)	280°C

*Stresses greater than those listed above may cause permanent damage to the device. These are stress ratings only; functional operation of the device at these or any other conditions greater than those indicated in the operational sections of this specification is not implied. Exposure to absolute maximum rating conditions for extended periods may affect device reliability.

Thermal Characteristics

196-Lead Ball Grid Array:

$$\theta_{JA} = 26.3^{\circ}\text{C}/\text{W}, \text{ No Airflow}$$

$$\theta_{JA} = 22^{\circ}\text{C}/\text{W}, \text{ 200 LFPM Airflow}$$

Thermal measurements made in the horizontal position on a 4-layer board.

EXPLANATION OF TEST LEVELS

- I. 100% Production Tested.
- II. 100% Production Tested at 25°C, and Sample Tested at Specified Temperatures.
- III. Sample Tested Only.
- IV. Parameter Guaranteed by Design and Analysis.
- V. Parameter is Typical Value Only.
- VI. 100% Production Tested at 25°C, and Sample Tested at Temperature Extremes.

ORDERING GUIDE

Model	Temperature Range	Package Description	Package Option
AD6624AABC	-40°C to +85°C (Ambient)	196-Lead BGA (Ball Grid Array)	BC-196
AD6624AS/PCB		Evaluation Board with AD6624A and Software	

CAUTION

ESD (electrostatic discharge) sensitive device. Electrostatic charges as high as 4000 V readily accumulate on the human body and test equipment and can discharge without detection. Although the AD6624A features proprietary ESD protection circuitry, permanent damage may occur on devices subjected to high-energy electrostatic discharges. Therefore, proper ESD precautions are recommended to avoid performance degradation or loss of functionality.



AD6624A

PIN CONFIGURATION (Top View)

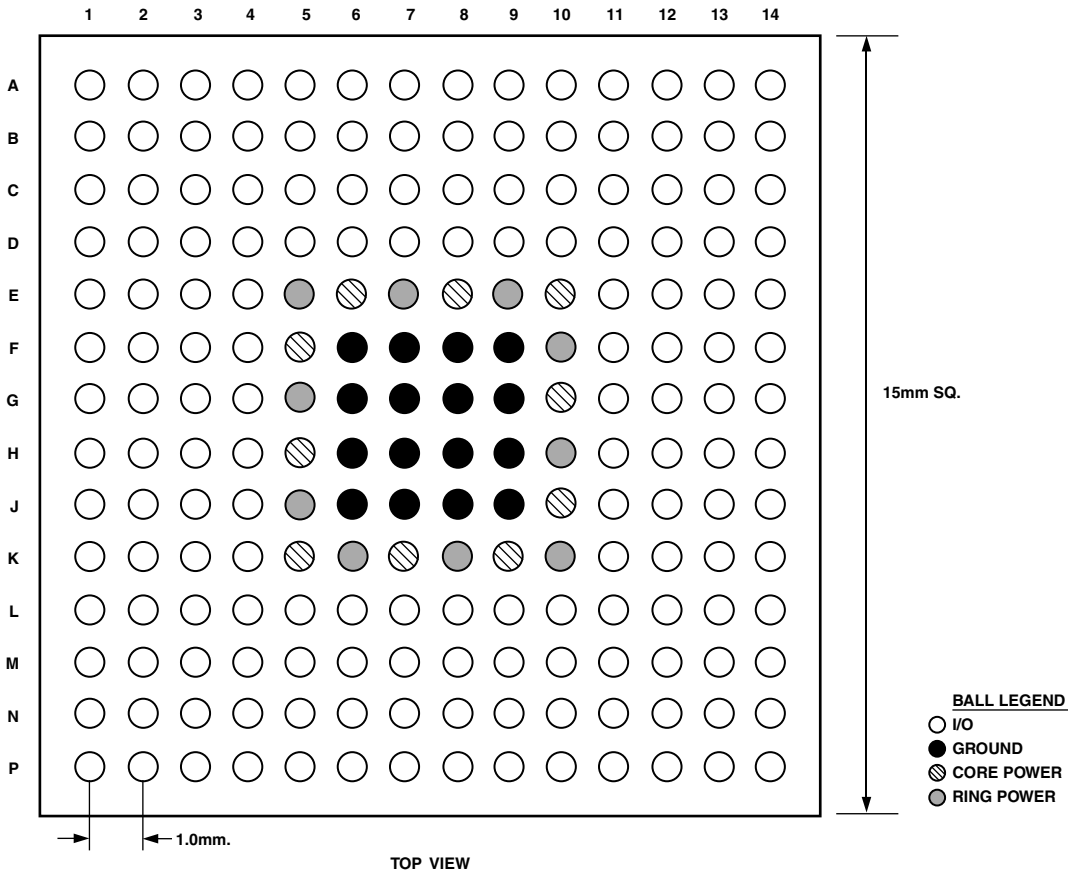

	1	2	3	4	5	6	7	8	9	10	11	12	13	14
A	NC		INB5	INB6		INB12	EXPB1	EXPB0	SDIN3	SDFS3	DR2		NO SDFS2	NC
B	INB3			INB4	INB7	INB10	INB13	DR3	SDO3	SDFE2	SDO2			
C	INB1			INB8		INB9	INB11	EXPB2	SDFE3	SCLK3	SDIN2	SCLK2		SDFE1
D	LIB-B	INB2	INB0									SDFS1	DR1	SDIN1
E	CLK	IENB	LIB-A		VDDIO	VDD	VDDIO	VDD	VDDIO	VDD			SDO1	
F	EXPA1	EXPA0	EXPA2		VDD	GND	GND	GND	GND	VDDIO		SCLK1	DR0	SDIN0
G	INA12	INA13	INA10		VDDIO	GND	GND	GND	GND	VDD		SDFE0	SDO0	SCLK0
H	INA11	INA9	INA7		VDD	GND	GND	GND	GND	VDDIO		SDFS0	SDIV1	SDIV0
J	INA8	INA6	INA4		VDDIO	GND	GND	GND	GND	VDD		SDIV2	SMB0	SDIV3
K	INA5	INA2	INA0		VDD	VDDIO	VDD	VDDIO	VDD	VDDIO		CHIP_ID1	CHIP_ID3	CHIP_ID0
L	INA1		INA3									TDI	TMS	CHIP_ID2
M	IENA			SYNCD	SYNCA	D5	D2	$\overline{DS}(\overline{RD})$		A0	MODE	\overline{TRST}		TD0
N				LIA-A	SYNCC	D7	D4	D1	$\overline{DTACK}(\overline{RDY})$	A2	\overline{CS}			TCLK
P	NC	LIA-B		SYNCB	RESET	D6		D3	D0	RW(\overline{WR})	A1			NC

NC = NO CONNECT

PIN FUNCTION DESCRIPTIONS 196-LEAD BGA

Pin No.	Type	Function
POWER SUPPLY		
VDD	P	2.5 V Supply
VDDIO	P	3.3 V IO Supply
GND	G	Ground
INPUTS		
INA[13:0] ¹	I	A Input Data (Mantissa)
EXPA[2:0] ¹	I	A Input Data (Exponent)
IENA ²	I	Input Enable—Input A
INB[13:0] ¹	I	B Input Data (Mantissa)
EXPB[2:0] ¹	I	B Input Data (Exponent)
IENB ²	I	Input Enable—Input B
$\overline{\text{RESET}}$	I	Active Low Reset Pin
CLK	I	Input Clock
SYNCA ¹	I	All Sync Pins Go to All Four Output Channels
SYNCB ¹	I	All Sync Pins Go to All Four Output Channels
SYNCC ¹	I	All Sync Pins Go to All Four Output Channels
SYNCD ¹	I	All Sync Pins Go to All Four Output Channels
SDIN0 ¹	I	Serial Data Input—Channel 0
SDIN1 ¹	I	Serial Data Input—Channel 1
SDIN2 ¹	I	Serial Data Input—Channel 2
SDIN3 ¹	I	Serial Data Input—Channel 3
$\overline{\text{CS}}$ ¹	I	Chip Select
CHIP_ID[3:0] ¹	I	Chip ID Selector
CONTROL		
SBM0 ¹	I	Serial Bus Master—Channel 0 only
SCLK0 ¹	I/O	Bidirectional Serial Clock—Channel 0
SCLK1 ¹	I/O	Bidirectional Serial Clock—Channel 1
SCLK2 ¹	I/O	Bidirectional Serial Clock—Channel 2
SCLK3 ¹	I/O	Bidirectional Serial Clock—Channel 3
SDIV[3:0] ¹	I	Serial Clock Divisor—Channel 0
SDFS0 ¹	I/O	Bidirectional Serial Data Frame Sync—Channel 0
SDFS1 ¹	I/O	Bidirectional Serial Data Frame Sync—Channel 1
SDFS2 ¹	I/O	Bidirectional Serial Data Frame Sync—Channel 2
SDFS3 ¹	I/O	Bidirectional Serial Data Frame Sync—Channel 3
SDFE0	O	Serial Data Frame End—Channel 0
SDFE1	O	Serial Data Frame End—Channel 1
SDFE2	O	Serial Data Frame End—Channel 2
SDFE3	O	Serial Data Frame End—Channel 3
MICROPORT CONTROL		
D[7:0]	I/O/T	Bidirectional Microport Data
A[2:0]	I	Microport Address Bus
$\overline{\text{DS}}$ ($\overline{\text{RD}}$)	I	Active Low Data Strobe (Active Low Read)
$\overline{\text{DTACK}}$ ($\overline{\text{RDY}}$) ²	O/T	Active Low Data Acknowledge (Microport Status Bit)
RW ($\overline{\text{WR}}$)	I	Read Write (Active Low Write)
MODE	I	Intel or Motorola Mode Select

AD6624A

PIN FUNCTION DESCRIPTIONS 196-LEAD BGA (continued)

Pin No.	Type	Function
OUTPUT		
LIA-A	O	Level Indicator—Input A, Interleaved-Data A
LIA-B	O	Level Indicator—Input A, Interleaved-Data B
LIB-B	O	Level Indicator—Input B, Interleaved-Data B
LIB-A	O	Level Indicator—Input B, Interleaved-Data A
SDO0 ¹	O/T	Serial Data Output—Channel 0
SDO1 ¹	O/T	Serial Data Output—Channel 1
SDO2 ¹	O/T	Serial Data Output—Channel 2
SDO3 ¹	O/T	Serial Data Output—Channel 3
DR0	O	Output Data Ready Indicator—Channel 0
DR1	O	Output Data Ready Indicator—Channel 1
DR2	O	Output Data Ready Indicator—Channel 3
DR3	O	Output Data Ready Indicator—Channel 3
JTAG and BIST		
$\overline{\text{TRST}}$ ²	I	Test Reset Pin
TCLK ¹	I	Test Clock Input
TMS ²	I	Test Mode Input
TDO	O/T	Test Data Output
TDI ²	I	Test Data Input

NOTES

¹Pins with a pull-down resistor of nominal 70 k Ω .

²Pins with a pull-up resistors of nominal 70 k Ω .

ARCHITECTURE

The AD6624A has four signal processing stages: a Frequency Translator, second order Resampling Cascaded Integrator Comb FIR filters (rCIC2), a fifth order Cascaded Integrator Comb FIR filter (CIC5) and a RAM Coefficient FIR filter (RCF). Multiple modes are supported for clocking data into and out of the chip, and provide flexibility for interfacing to a wide variety of digitizers. Programming and control is accomplished via serial and microprocessor interfaces.

Frequency translation is accomplished with a 32-bit complex Numerically Controlled Oscillator (NCO). Real data entering this stage is separated into in-phase (I) and quadrature (Q) components. This stage translates the input signal from a digital intermediate frequency (IF) to digital baseband. Phase and amplitude dither may be enabled on-chip to improve spurious performance of the NCO. A phase-offset word is available to create a known phase relationship between multiple AD6624As or between channels.

Following frequency translation is a resampling, fixed-coefficient, high-speed, second order, Resampling Cascade Integrator Comb (rCIC2) filter that reduces the sample rate based on the ratio between the decimation and interpolation registers.

The next stage is a fifth order Cascaded Integrator Comb (CIC5) filter whose response is defined by the decimation rate. The purpose of these filters is to reduce the data rate to the final filter stage so it can calculate more taps per output.

The final stage is a sum-of-products FIR filter with programmable 20-bit coefficients, and decimation rates programmable from 1 to 256 (1–32 in practice). The RAM Coefficient FIR filter (RCF in the Functional Block Diagram) can handle a maximum of 160 taps.

The overall filter response for the AD6624A is the composite of all decimating and interpolating stages. Each successive filter stage is capable of narrower transition bandwidths but requires a greater number of CLK cycles to calculate the output. More decimation in the first filter stage will minimize overall power consumption. Data from the chip is interfaced to the DSP via a high-speed synchronous serial port.

Figure 18a illustrates the basic function of the AD6624A: to select and filter a single channel from a wide input spectrum. The frequency translator “tunes” the desired carrier to baseband. Figure 18b shows the combined filter response of the rCIC2, CIC5, and RCF.

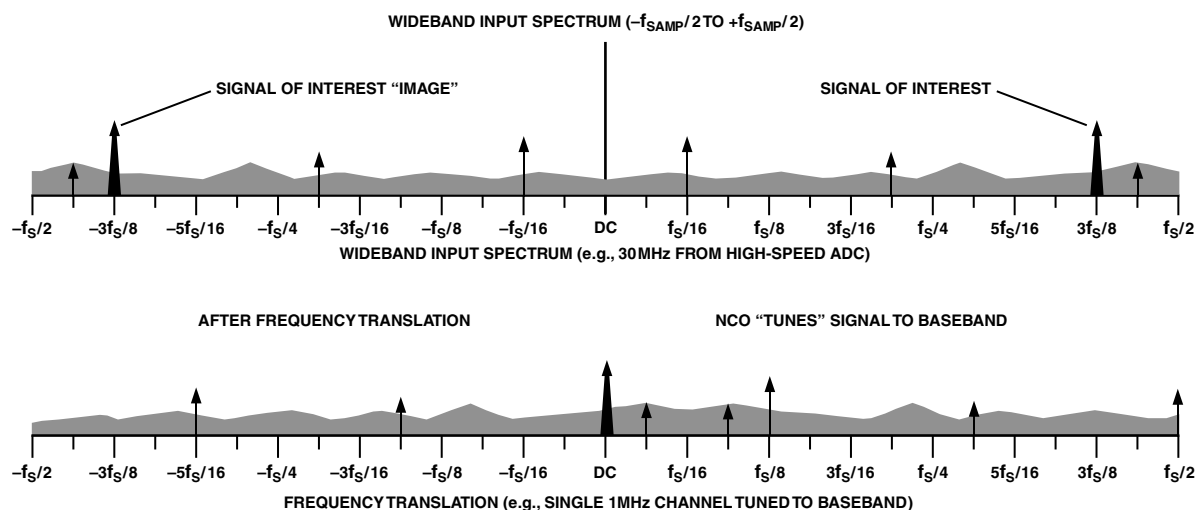

Figure 18a. Frequency Translation of Wideband Input Spectrum

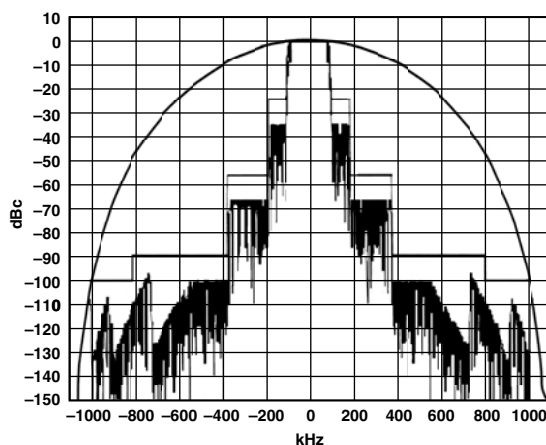

Figure 18b. Composite Filter Response of rCIC2, CIC5, and RCF

AD6624A

EXAMPLE FILTER RESPONSE

The filter in Figure 19 is based on a 65 MSPS input data rate and an output rate of 541.6666 kSPS (two samples per symbol for EDGE). Total decimation rate is 120 distributed between the rCIC2, CIC5 and RCF.

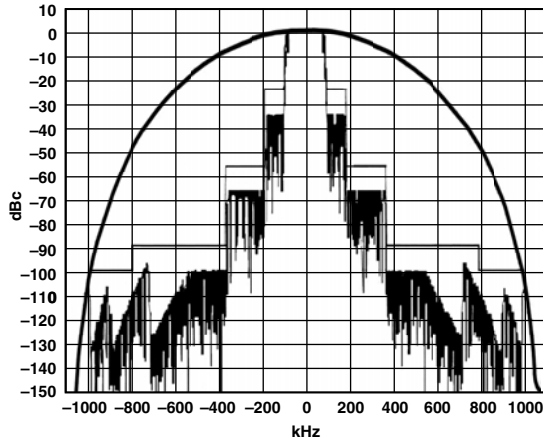

Figure 19. Filter Response

The filter in Figure 20 is designed to meet the IS-136 specifications. For this configuration, the clock is set to 61.44 MSPS with a total decimation rate of 320 providing an output data rate of 192 kSPS or four samples per symbol.

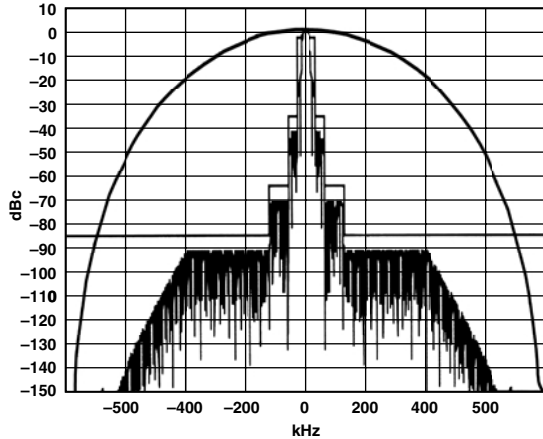

Figure 20. Filter Response

INPUT DATA PORTS

The AD6624A features dual, high-speed ADC input ports, Input Port A and Input Port B. The dual input ports allow for the most flexibility with a single tuner chip. These can be diversity inputs or truly independent inputs such as separate antenna segments. Either ADC port can be routed to one of four tuner channels. For added flexibility, each input port can be used to support multiplexed inputs such as found on the AD6600 or other ADCs with mixed outputs. This added flexibility can allow for up to four different analog sources to be processed simultaneously by the four internal channels.

In addition, the front end of the AD6624A contains circuitry that enables high-speed signal level detection and control. This is accomplished with a unique high-speed level detection circuit

that offers minimal latency and maximum flexibility to control up to four analog signal paths. The overall signal path latency from input to output on the AD6624A can be expressed in high-speed clock cycles. The equation below can be used to calculate the latency.

$$T_{LATENCY} = M_{rCIC2}(M_{CIC5} + 7) + N_{TAPS} + 4(SDIV + 1) + 18$$

M_{rCIC2} and M_{CIC5} are decimation values for the rCIC2 and CIC5 filters respectively, N_{TAPS} is the number RCF taps chosen, and $SDIV$ is the chosen SCLK divisor factor.

Input Data Format

Each input port consists of a 14-bit mantissa and 3-bit exponent. If interfacing to a standard ADC is required, the exponent bits can be grounded. If connected to a floating point ADC such as the AD6600, the exponent bits from that product can be connected to the input exponent bits of the AD6624A. The mantissa data format is two's-complement and the exponent is unsigned binary.

Input Timing

The data from each high-speed input port is latched on the rising edge of CLK. This clock signal is used to sample the input port and clock the synchronous signal processing stages that follow in the selected channels.

The clock signals can operate up to 80 MHz and have a 50% duty cycle. In applications using high-speed ADCs, the ADC sample clock or data valid strobe is typically used to clock the AD6624A.

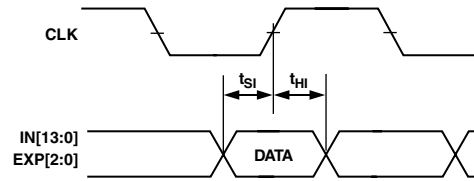

Figure 21. Input Data Timing Requirements

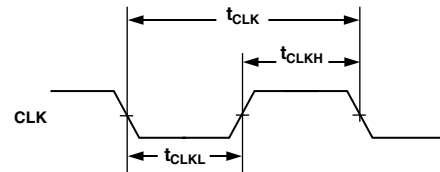

Figure 22. CLK Timing Requirements

Input Enable Control

There is an IENA and an IENB pin for the Input Port A and Input Port B respectively. There are four modes of operation used for each IEN pin. Using these modes, it is possible to emulate operation of the other RSPs such as the AD6620, which offer dual channel modes normally associated with diversity operations. These modes are: IEN transition to low, IEN transition to high, IEN high, and blank on IEN low.

In the IEN high mode, the inputs and normal operations occur when the Input Enable is high. In the IEN transition to low mode, normal operations occur on the first rising edge of the clock after the IEN transitions to low. Likewise, in the IEN transition to high mode, operations occur on the rising edge of the clock after the IEN transitions to high. See the Numerically Controlled Oscillator section for more details on configuring the Input Enable Modes. In blank on IEN low mode, the input data is interpreted as zero when IEN is low.

A typical application for this feature would be to take the data from an AD6600 Diversity ADC to one of the inputs of the AD6624A. The A/B_OUT from that chip would be tied to the IEN. One channel within the AD6624A would be then set so that IEN transition to low is enabled. Another channel would be configured so that IEN transition to high is enabled. One of the serial outputs would be configured as the Serial Bus Master and the other as a serial bus slave and the output bus configured as shown in Figure 25. This would allow two of the AD6624A channels to be configured to emulate that AD6620 in diversity mode. Of course the NCO frequencies and other channel characteristics would need to be set similarly, but this feature allows the AD6624A to handle interleaved data streams such as found on the AD6600.

The difference between the IEN transition to high and the IEN high is found when a system clock is provided that is higher than the data rate of the converter. It is often advantageous to supply a clock that runs faster than the data rate so that additional filter taps can be computed. This naturally provides better filtering. In order to ensure that other parts of the circuit properly recognize the faster clock in the simplest manner, the IEN transition to low or high should be used. In this mode, only the first clock edge that meets the setup and hold times will be used to latch and process the input data. All other clock pulses are ignored by front end processing. However, each clock cycle will still produce a new filter computation pair.

Gain Switching

The AD6624A includes circuitry that is useful in applications where either large dynamic ranges exist or where gain ranging converters are employed. This circuitry allows digital thresholds to be set such that an upper and a lower threshold can be programmed.

One such use of this may be to detect when an ADC converter is about to reach full-scale with a particular input condition. The result would be to provide a flag that could be used to quickly insert an attenuator that would prevent ADC overdrive. If 18 dB (or any arbitrary value) of attenuation (or gain) is switched in, the signal dynamic range of the system will have been increased by 18 dB. The process begins when the input signal reaches the upper programmed threshold. In a typical application, this may be set 1 dB (user-definable) below full-scale. When this input condition is met, the appropriate LI (LIA-A, LIA-B, LIB-A, or LIB-B) signal associated with either the A or B input port is made active. This can be used to switch the gain or attenuation of the external circuit. The LI signal stays active until the input condition falls below the lower programmed threshold. To provide hysteresis, a dwell-time register (see Memory Map for Input Control Registers) is available to hold off switching of the control line for a predetermined number of clocks. Once the input condition is below the lower threshold, the programmable counter begins counting high-speed clocks. As long as the input signal stays below the lower threshold for the number of high-speed clock cycles programmed, the attenuator will be removed on the terminal count. However, if the input condition goes above the lower threshold with the counter running, it will be reset and must fall below the lower threshold again to initiate the process. This will prevent unnecessary switching between states.

This is illustrated in Figure 23. When the input signal goes above the upper threshold, the appropriate LI signal becomes active. Once the signal falls below the lower threshold, the counter begins counting. If the input condition goes above the lower threshold, the counter is reset and starts again as shown in Figure 23. Once the counter has terminated to zero, the LI signal goes inactive.

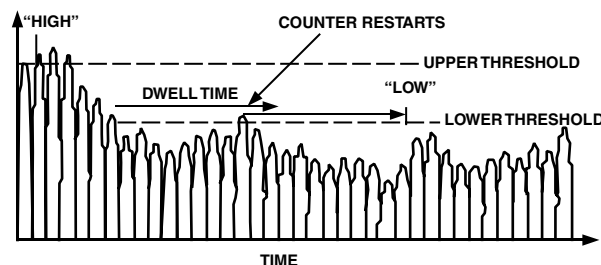

Figure 23. Threshold Settings for LI

The LI signal can be used for a variety of functions. It can be used to set the controls of an attenuator DVGA or integrated and used with an analog VGA. To simplify the use of this feature, the AD6624A includes two separate gain settings, one when this line is inactive (rCIC2_QUIET[4:0]) and the other when active (rCIC2_LOUD[4:0]). This allows the digital gain to be adjusted to the external changes. In conjunction with the gain setting, a variable hold-off is included to compensate for the pipeline delay of the ADC and the switching time of the gain control element. Together, these two features provide seamless gain switching.

Another use of these pins is to facilitate a gain range hold-off within a gain-ranging ADC. For converters that use gain ranging to increase total signal dynamic range, it may be desirable to prohibit internal gain ranging from occurring in some instances. For such converters, the LI (A or B) signals can be used to hold this off. For this application, the upper threshold would be set based on similar criteria. However, the lower threshold would be set to a level consistent with the gain ranges of the specific converter. The hold-off delay can then be set appropriately for any number of factors such as fading profile, signal peak to average ratio, or any other time-based characteristics that might cause unnecessary gain changes.

Since the AD6624A has a total of four gain control circuits that can be used if both A and B Input Ports have interleaved data, each respective LI pin is independent and can be set to different set points. It should be noted that the gain control circuits are wideband and are implemented prior to any filtering elements to minimize loop delay. Any of the four channels can be set to monitor any of the possible four input channels (two in normal mode and four when the inputs are time-multiplexed).

The chip also provides appropriate scaling of the internal data based on the attenuation associated with the LI signal. In this manner, data to the DSP maintains a correct scale value throughout the process, making it totally independent. Since finite delays are often associated with external gain switching components, the AD6624A includes a variable pipeline delay that can be used to compensate for external pipeline delays or gross settling times associated with gain/attenuator devices. This delay may be set up to seven high-speed clocks. These features ensure smooth switching between gain settings.

AD6624A

Input Data Scaling

The AD6624A has two data input ports: an A Input Port and a B Input Port. Each accepts 14-bit mantissa (*two's-complement integer*) IN[13:0], a 3-bit exponent (*unsigned integer*) EXP[2:0] and the Input Enable (IEN). Both inputs are clocked by CLK. These pins allow direct interfacing to both standard fixed-point ADCs such as the AD9225 and AD6640, as well as to gain-ranging ADCs such as the AD6600. For normal operation with ADCs having fewer than 14 bits, the active bits should be MSB-justified and the unused LSBs should be tied low.

The 3-bit exponent, EXP[2:0], is interpreted as an unsigned integer. The exponent will subsequently be modified by either of the 5-bit scale values stored in register 0x92, Bits 4–0 or Bits 9–5. These 5-bit registers contain the sum of the rCIC2 scale value plus the external attenuator scale settings and the Exponent Offset (ExpOff). If no external attenuator is used, these values can only be set to the value of the rCIC2 scale. If an external attenuator is used, Bit Position 4–0 (Register 0x92 rCIC2_LOUD[4:0]) contains the scale value for the largest input range. Bit Positions 9–5 (Register 0x92 rCIC2_QUIET[4:0]) are used for the nonattenuated input signal range.

Scaling with Fixed-Point ADCs

For fixed-point ADCs, the AD6624A exponent inputs EXP[2:0] are typically not used and should be tied low. The ADC outputs are tied directly to the AD6624A Inputs, MSB-justified. The ExpOff bits in 0x92 should be programmed to 0. Likewise, the Exponent Invert bit should be 0.

Thus for fixed-point ADCs, the exponents are typically static and no input scaling is used in the AD6624A.

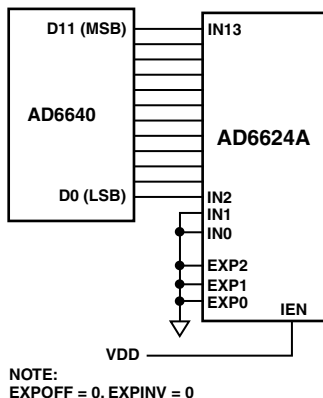

Figure 24. Typical Interconnection of the AD6640 Fixed Point ADC and the AD6624A

Scaling with Floating-Point or Gain-Ranging ADCs

An example of the exponent control feature combines the AD6600 and the AD6624A. The AD6600 is an 11-bit ADC with three bits of gain ranging. In effect, the 11-bit ADC provides the mantissa, and the three bits of relative signal strength indicator (RSSI) for the exponent. Only five of the eight available steps are used by the AD6600. See the AD6600 data sheet for additional details.

For gain-ranging ADCs such as the AD6600,

$$\text{scaled_input} = IN \times 2^{-\text{mod}(7-\text{Exp}+\text{rCIC2},8)}, \quad (1)$$

$$\text{ExpInv} = 1, \text{ExpWeight} = 0$$

where: *IN* is the value of IN[13:0], *Exp* is the value of EXP[2:0], and *rCIC2* is the rCIC scale register value (0x92 Bits 9–5 and 4–0).

The RSSI output of the AD6600 numerically grows with increasing signal strength of the analog input (RSSI = 5 for a large signal, RSSI = 0 for a small signal). When the Exponent Invert Bit (ExpInv) is set to zero, the AD6624A will consider the smallest signal at the IN[13:0] to be the largest and as the EXP word increases, it shifts the data down internally (EXP = 5 will shift a 14-bit word right by five internal bits before passing the data to the rCIC2). In this example, where ExpInv = 0, the AD6624A regards the largest signal possible on the AD6600 as the smallest signal. Thus, the Exponent Invert Bit can be used to make the AD6624A exponent agree with the AD6600 RSSI. By setting ExpInv = 1, it forces the AD6624A to shift the data up (left) for growing EXP instead of down. The exponent invert bit should always be set high for use with the AD6600.

The Exponent Offset is used to shift the data right. For example, Table I shows that with no rCIC2 scaling, 12 dB of range is lost when the ADC input is at the largest level. This is undesirable because it lowers the Dynamic Range and SNR of the system by reducing the signal of interest relative to the quantization noise floor.

Table I. AD6600 Transfer Function with AD6624A ExpInv = 1, and No ExpOff

ADC Input Level	AD6600 RSSI[2:0]	AD6624A Data	Signal Reduction
Largest	101 (5)	÷ 4 (>> 2)	-12 dB
	100 (4)	÷ 8 (>> 3)	-18 dB
	011 (3)	÷ 16 (>> 4)	-24 dB
	010 (2)	÷ 32 (>> 5)	-30 dB
	001 (1)	÷ 64 (>> 6)	-36 dB
Smallest	000 (0)	÷ 128 (>> 7)	-42 dB

(ExpInv = 1, ExpOff = 0)

To avoid this automatic attenuation of the full-scale ADC signal, the ExpOff is used to move the largest signal (RSSI = 5) up to the point where there is no downshift. In other words, once the Exponent Invert bit has been set, the Exponent Offset should be adjusted so that $\text{mod}(7-5 + \text{ExpOff}, 8) = 0$. This is the case when Exponent Offset is set to 6 since $\text{mod}(8, 8) = 0$. Table II illustrates the use of ExpInv and ExpOff when used with the AD6600 ADC.

Table II. AD6600 Transfer Function with AD6624A ExpInv = 1, and ExpOff = 6

ADC Input Level	AD6600 RSSI[2:0]	AD6624A Data	Signal Reduction
Largest	101 (5)	÷ 1 (>> 0)	-0 dB
	100 (4)	÷ 2 (>> 1)	-6 dB
	011 (3)	÷ 4 (>> 2)	-12 dB
	010 (2)	÷ 8 (>> 3)	-18 dB
	001 (1)	÷ 16 (>> 4)	-24 dB
Smallest	000 (0)	÷ 32 (>> 5)	-30 dB

(ExpInv = 1, ExpOff = 6)

This flexibility in handling the exponent allows the AD6624A to interface with gain-ranging ADCs other than the AD6600. The Exponent Offset can be adjusted to allow up to seven RSSI(EXP) ranges to be used as opposed to the AD6600's five.

It also allows the AD6624A to be tailored in a system that employs the AD6600, but does not utilize all of its signal range. For example, if only the first four RSSI ranges are expected to occur, the ExpOff could be adjusted to five, which would then make RSSI = 4 correspond to the 0 dB point of the AD6624A.

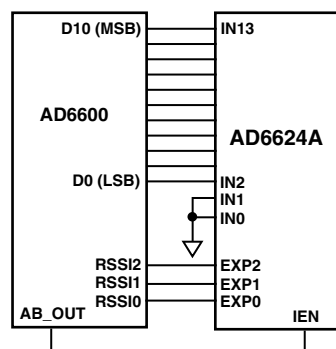

Figure 25. Typical Interconnection of the AD6600 Gain-Ranging ADC and the AD6624A

NUMERICALLY CONTROLLED OSCILLATOR

Frequency Translation

This processing stage comprises a digital tuner consisting of two multipliers and a 32-bit complex NCO. Each channel of the AD6624A has an independent NCO. The NCO serves as a quadrature local oscillator capable of producing an NCO frequency between $-\text{CLK}/2$ and $+\text{CLK}/2$ with a resolution of $\text{CLK}/2^{32}$ in the complex mode. The worst-case spurious signal from the NCO is better than -100 dBc for all output frequencies.

The NCO frequency value in registers 0x85 and 0x86 are interpreted as a 32-bit unsigned integer. The NCO frequency is calculated using the equation below.

$$\text{NCO_FREQ} = 2^{32} \times \text{mod} \left(\frac{f_{\text{CHANNEL}}}{\text{CLK}} \right) \quad (2)$$

NCO_FREQ is the 32-bit integer (Registers 0x85 and 0x86), f_{CHANNEL} is the desired channel frequency, and CLK^* is the AD6624A master clock rate (CLK).

NCO Frequency Hold-Off Register

When the NCO Frequency registers are written, data is actually passed to a shadow register. Data may be moved to the main registers by one of two methods. The first is to start the chip using the soft sync feature, which will directly load the NCO registers. The second allows changes to be pre-written and then updated through direct software control. To accomplish this, there is an NCO Frequency Hold-Off Counter. The counter (0x84) is a 16-bit unsigned integer and is clocked at the master CLK rate. This hold-off counter is also used in conjunction with the frequency hopping feature of this chip.

Phase Offset

The phase offset register (0x87) adds an offset to the phase accumulator of the NCO. This is a 16-bit register and is interpreted as a 16-bit unsigned integer. A 0x0000 in this register corresponds to a 0 radian offset and a 0xFFFF corresponds to an offset of $2\pi(1 - 1/2^{16})$ radians. This register allows multiple NCOs to be synchronized to produce sine waves with a known and steady phase difference.

NCO Control Register

The NCO control register located at 0x88 is used to configure the features of the NCO. These are controlled on a per-channel basis. These are described below.

Bypass

The NCO in the front end of the AD6624A can be bypassed. Bypass mode is enabled by setting Bit 0 of 0x88 high. When they are bypassed, down conversion is not performed and the AD6624A channel functions simply as a real filter on complex data. This is useful for passband sampling application where the A input is connected to the I signal path within the filter and the B input is connected to the Q signal path. This may be desired if the digitized signal has already been converted to passband in prior analog stages or by other digital preprocessing.

Phase Dither

The AD6624A provides a phase dither option for improving the spurious performance of the NCO. Phase dither is enabled by setting Bit 1. When phase dither is enabled by setting this bit high, spurs due to phase truncation in the NCO are randomized. The energy from these spurs is spread into the noise floor and Spurious Free Dynamic Range is increased at the expense of very slight decreases in the SNR. The choice of whether phase dither is used in a system will ultimately be decided by the system goals. If lower spurs are desired at the expense of a slightly raised noise floor, it should be employed. If a low noise floor is desired and the higher spurs can be tolerated or filtered by subsequent stages, phase dither is not needed.

Amplitude Dither

Amplitude dither can also be used to improve spurious performance of the NCO. Amplitude dither is enabled by setting Bit 2. Amplitude dither improves performance by randomizing the amplitude quantization errors within the angular to Cartesian conversion of the NCO. This option may reduce spurs at the expense of a slightly raised noise floor. Amplitude dither and phase dither can be used together, separately, or not at all.

Clear Phase Accumulator on HOP

When Bit 3 is set, the NCO phase accumulator is cleared prior to a frequency hop. This ensures a consistent phase of the NCO on each hop. The NCO phase offset is unaffected by this setting and is still in effect. If phase-continuous hopping is desired, this bit should be cleared and the last phase in the NCO phase register will be the initiating point for the new frequency.

Input Enable Control

There are four different modes of operation for the input enable. Each of the high-speed input ports includes an IEN line. Any of the four filter channels can be programmed to take data from either of the two A or B Input Ports (see WB Input Select section). Along with data is the IEN(A, B) signal. Each filter channel can be configured to process the IEN signal in one of four modes. Three of the modes are associated with when data is processed based on a time division multiplexed data stream. The fourth mode is used in applications that employ time division duplex such as radar, sonar, ultrasound, and communications that involve TDD.

Mode 00: Blank On IEN Low

In this mode, data is blanked while the IEN line is low. During the period of time when the IEN line is high, new data is strobed on each rising edge of the input clock. When the IEN line is

*See NCO Mode Control section.

AD6624A

lowered, input data is replaced with zero values. During this period, the NCO continues to run such that when the IEN line is raised again, the NCO value will be at the value it would have otherwise been in had the IEN line never been lowered. This mode has the effect of blanking the digital inputs when the IEN line is lowered. Back end processing (rCIC2, CIC5, and RCF) continues while the IEN line is high. This mode is useful for time division multiplexed applications.

Mode 01: Clock On IEN High

In this mode, data is clocked into the chip while the IEN line is high. During the period of time when the IEN line is high, new data is strobed on each rising edge of the input clock. When IEN line is lowered, input data is no longer latched into the channel. Additionally, NCO advances are halted. However, back end processing (rCIC2, CIC5, and RCF) continues during this period. The primary use for this mode is to allow for a clock that is faster than the input sample data rate to allow more filter taps to be computed than would otherwise be possible. In Figure 26, input data is strobed only during the period of time when IEN is high, despite the fact that the CLK continues to run at a rate four times faster than the data.

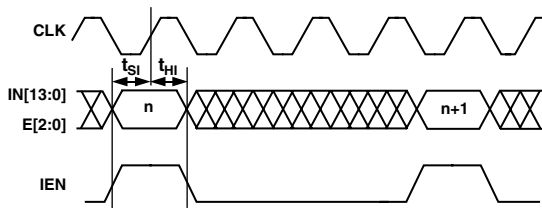

Figure 26. Fractional Rate Input Timing ($4 \times \text{CLK}$) in Mode 01

Mode 10: Clock on IEN Transition to High

In this mode, data is clocked into the chip only on the first clock edge after the rising transition of the IEN line. Although data is only latched on the first valid clock edge, the back end processing (rCIC2, CIC5, and RCF) continues on each available clock that may be present, similar to Mode 01. The NCO phase accumulator is incremented only once for each new input data sample and not once for each input clock.

Mode 11: Clock on IEN Transition to Low

In this mode, data is clocked into the chip only on the first clock edge after the falling transition of the IEN line. Although data is only latched on the first valid clock edge, the back end processing (rCIC2, CIC5, and RCF) continues on each available clock that may be present, similar to Mode 01. The NCO phase accumulator is incremented only once for each new input data sample and not once for each input clock.

WB Input Select

Bit 6 in this register controls which input port is selected for signal processing. If this bit is set high, Input Port B (INB, EXPB, and IENB) is connected to the selected filter channel. If this bit is cleared, Input Port A (INA, EXPA, and IENA) is connected to the selected filter channel.

Sync Select

Bits 7 and 8 of this register determine which external sync pin is associated with the selected channel. The AD6624A has four sync pins named SYNCA, SYNCB, SYNCC, and SYNCD. Any of these sync pins can be associated with any of the four receiver

channels within the AD6624A. Additionally, if only one sync signal is required for the system, all four receiver channels can reference the same sync pulse. Bit value 00 is Channel A, 01 is Channel B, 10 is Channel C, and 11 is Channel D.

SECOND ORDER rCIC FILTER

The rCIC2 filter is a second order cascaded resampling integrator comb filter. The resampler is implemented using a unique technique, which does not require the use of a high-speed clock, thus simplifying the design and saving power. The resampler allows for noninteger relationships between the master clock and the output data rate. This allows easier implementation of systems that are either multimode or require a master clock that is not a multiple of the data rate to be used.

Interpolation up to 512, and decimation up to 4096, is allowed in the rCIC2. The resampling factor for the rCIC2 (L) is a 9-bit integer. When combined with the decimation factor M , a 12-bit number, the total rate change can be any fraction in the form of:

$$R_{rCIC2} = \frac{L}{M} \quad (3)$$

$$R_{rCIC2} \leq 1$$

The only constraint is that the ratio L/M must be less than or equal to one. This implies that the rCIC2 decimates by 1 or more.

Resampling is implemented by apparently increasing the input sample rate by the Factor L , using zero stuffing for the new data samples. Following the resampler is a second order cascaded integrator comb filter. Filter characteristics are determined only by the fractional rate change (L/M).

The filter can process signals at the full rate of the input port 80 MHz. The output rate of this stage is given by Equation 4.

$$f_{SAMP2} = \frac{L_{rCIC2} \times f_{SAMP}}{M_{rCIC2}} \quad (4)$$

Both L_{rCIC2} and M_{rCIC2} are unsigned integers. The interpolation rate (L_{rCIC2}) may be from 1 to 512 and the decimation (M_{rCIC2}) may be between 1 and 4096. The stage can be bypassed by setting the decimation to 1/1.

The frequency response of the rCIC2 filter is given by Equation 5.

$$H(z) = \frac{1}{2^{S_{rCIC2}} \times L_{rCIC2}} \times \left(\frac{1 - z^{-\frac{M_{rCIC2}}{L_{rCIC2}}}}{1 - z^{-1}} \right)^2$$

$$H(f) = \frac{1}{2^{S_{rCIC2}} \times L_{rCIC2}} \times \left(\frac{\sin\left(\pi \frac{M_{rCIC2} \times f}{L_{rCIC2} \times f_{SAMP}}\right)}{\sin\left(\pi \frac{f}{f_{SAMP}}\right)} \right)^2 \quad (5)$$

The scale factor, S_{rCIC2} is a programmable, unsigned 5-bit value between 0 and 31. This serves as an attenuator that can reduce the gain of the rCIC2 in 6 dB increments. For the best dynamic range, S_{rCIC2} should be set to the smallest value possible (i.e., lowest attenuation) without creating an overflow condition. This can be safely accomplished using the following equation:

$$S_{rCIC2} = \text{ceil} \left[\log_2 \left(M_{rCIC2} + \text{floor} \left(\frac{M_{rCIC2}}{L_{rCIC2}} \right) \times \left(2 \times M_{rCIC2} - L_{rCIC2} \times \text{floor} \left(\frac{M_{rCIC2}}{L_{rCIC2}} + 1 \right) \right) \right) \right]$$

$$OL_{rCIC2} = \frac{(M_{rCIC2})^2}{L_{rCIC2} \times 2^{S_{rCIC2}}} \times \text{input_level} \quad (6)$$

where *input_level* is the largest fraction of full-scale possible at the input to the AD6624A (normally 1). The rCIC2 scale factor is always used whether or not the rCIC2 is bypassed.

Moreover, there are two scale registers (rCIC2_LOUD[4:0] Bits 4–0 in 0x92), and (rCIC2_QUIET[4:0] Bits 9–5 in 0x92) that are used in conjunction with the computed S_{rCIC2} which determines the overall rCIC2 scaling. The S_{rCIC2} value must be summed with the values in each respective scale register and ExpOff, to determine the scale value that must be placed in the rCIC2 scale register. This number must be less than 32 or the interpolation and decimation rates must be adjusted to validate this equation. The ceil function denotes the next whole integer and the floor function denotes the previous whole integer. For example, the ceil(4.5) is 5 while the floor(4.5) is 4.

The gain and passband droop of the rCIC2 should be calculated by the equations above, as well as the filter transfer equations that follow. Excessive passband droop can be compensated for in the RCF stage by peaking the passband by the inverse of the roll-off.

$$\text{scaled_input} = IN \times 2^{-\text{mod}(Exp + rCIC2, 8)}, \text{ExpInv} = 0$$

$$\text{scaled_input} = IN \times 2^{-\text{mod}(7 - Exp + rCIC2, 8)}, \text{ExpInv} = 1 \quad (7)$$

where: *IN* is the value of IN[15:0], *Exp* is the value of EXP[2:0], and *rCIC2* is the value of the 0x92 (rCIC2_QUIET[4:0] and rCIC2_LOUD[4:0]) scale register.

rCIC2 Rejection

Table III illustrates the amount of bandwidth in percent of the data rate into the rCIC2 stage. The data in this table may be scaled to any other allowable sample rate up to 80 MHz in Single Channel Mode or 40 MHz in Diversity Channel Mode. The table can be used as a tool to decide how to distribute the decimation between rCIC2, CIC5, and the RCF.

Table III. SSB rCIC2 Alias Rejection Table ($f_{SAMP} = 1$)
Bandwidth Shown in Percentage of f_{SAMP}

M_{rCIC2}/L_{rCIC2}	-50 dB	-60 dB	-70 dB	-80 dB	-90 dB	-100 dB
2	1.79	1.007	0.566	0.318	0.179	0.101
3	1.508	0.858	0.486	0.274	0.155	0.087
4	1.217	0.696	0.395	0.223	0.126	0.071
5	1.006	0.577	0.328	0.186	0.105	0.059
6	0.853	0.49	0.279	0.158	0.089	0.05
7	0.739	0.425	0.242	0.137	0.077	0.044
8	0.651	0.374	0.213	0.121	0.068	0.038
9	0.581	0.334	0.19	0.108	0.061	0.034
10	0.525	0.302	0.172	0.097	0.055	0.031
11	0.478	0.275	0.157	0.089	0.05	0.028
12	0.439	0.253	0.144	0.082	0.046	0.026
13	0.406	0.234	0.133	0.075	0.043	0.024
14	0.378	0.217	0.124	0.07	0.04	0.022
15	0.353	0.203	0.116	0.066	0.037	0.021
16	0.331	0.19	0.109	0.061	0.035	0.02

Example Calculations

Goal: Implement a filter with an Input Sample Rate of 10 MHz requiring 100 dB of alias rejection for a ± 7 kHz passband.

Solution: First determine the percentage of the sample rate that is represented by the passband.

$$BW_{\text{FRACTION}} = 100 \times \frac{7 \text{ kHz}}{10 \text{ MHz}} = 0.07 \quad (8)$$

Find the -100 dB column in Table III and look down this column for a value greater than or equal to your passband percentage of the clock rate. Then look across to the extreme left column and find the corresponding rate-change factor (M_{rCIC2}/L_{rCIC2}). Referring to the table, notice that for a M_{rCIC2}/L_{rCIC2} of 4, the frequency having -100 dB of alias rejection is 0.071 percent, which is slightly greater than the 0.07 percent calculated. Therefore, for this example, the maximum bound on rCIC2 rate change is 4. A higher chosen M_{rCIC2}/L_{rCIC2} means less alias rejection than the 100 dB required.

An M_{rCIC2}/L_{rCIC2} of less than four would still yield the required rejection; however, the power consumption can be minimized by decimating as much as possible in this rCIC2 stage. Decimation in rCIC2 lowers the data rate, and thus reduces power consumed in subsequent stages. It should also be noted that there is more than one way to determine the decimation by 4. A decimation of 4 is the same as an L/M ratio of 0.25. Thus any integer combination of L/M that yields 0.25 will work (1/4, 2/8, or 4/16). However, for the best dynamic range, the simplest ratio should be used. For example, 1/4 gives better performance than 4/16.

Decimation and Interpolation Registers

rCIC2 decimation values are stored in register 0x90. This is a 12-bit register and contains the decimation portion less 1. The interpolation portion is stored in register 0x91. This 9-bit value holds the interpolation less one.

rCIC2 Scale

Register 0x92 contains the scaling information for this section of the circuit. The primary function is to store the scale value computed in the sections above.

Bits 4–0 (rCIC2_LOUD[4:0]) of this register are used to contain the scaling factor for the rCIC2 during conditions of strong signals. These five bits represent the rCIC2 scalar calculated above plus any external signal scaling with an attenuator.

Bits 9–5 (rCIC2_QUIET[4:0]) of this register are used to contain the scaling factor for the rCIC2 during conditions of weak signals. In this register, no external attenuator would be used and is not included. Only the value computed above is stored in these bits.

Bit 10 of this register is used to indicate the value of the external exponent. If this bit is set LOW, each external exponent represents 6 dB per step as in the AD6600. If this bit is set to HIGH, each exponent represents a 12 dB step.

AD6624A

Bit 11 of this register is used to invert the external exponent before internal calculation. This bit should be set HIGH for gain-ranging ADCs that use an increasing exponent to represent an increasing signal level. This bit should be set LOW for gain-ranging ADCs that use a decreasing exponent for representing an increasing signal level.

In applications that do not require the features of the rCIC2, it may be bypassed by setting the L/M ratio to 1/1. This effectively bypasses all circuitry of the rCIC2 except the scaling, which is still effectual.

FIFTH ORDER CASCADED INTEGRATOR COMB FILTER

The third signal processing stage, CIC5, implements a sharper fixed-coefficient, decimating filter than CIC2. The input rate to this filter is f_{SAMP2} . The maximum input rate is given by Equation 9. N_{CH} equals two for Diversity Channel Real input mode; otherwise N_{CH} equals one. In order to satisfy this equation, M_{CIC2} can be increased, N_{CH} can be reduced, or f_{CLK} can be increased (reference fractional rate input timing described in the Input Timing section).

$$f_{SAMP2} \leq \frac{f_{CLK}}{N_{CH}} \quad (9)$$

The decimation ratio, M_{CIC5} , may be programmed from 2 to 32 (all integer values). The frequency response of the filter is given by Equation 10. The gain and passband droop of CIC5 should be calculated by these equations. Both parameters may be compensated for in the RCF stage.

$$H(z) = \frac{1}{2^{S_{CIC5}+5}} \times \left(\frac{1-z^{-M_{CIC5}}}{1-z^{-1}} \right)^5 \quad (10)$$

$$H(f) = \frac{1}{2^{S_{CIC5}+5}} \times \left(\frac{\sin\left(\pi \frac{M_{CIC5} \times f}{f_{SAMP2}}\right)}{\sin\left(\pi \frac{f}{f_{SAMP2}}\right)} \right)^5$$

The scale factor, S_{CIC5} is a programmable unsigned integer between 0 and 20. It serves to control the attenuation of the data into the CIC5 stage in 6 dB increments. For the best dynamic range, S_{CIC5} should be set to the smallest value possible (lowest attenuation) without creating an overflow condition. This can be safely accomplished using Equation 11, where OL_{rCIC2} is the largest fraction of full scale possible at the input to this filter stage. This value is output from the rCIC2 stage, then pipelined into the CIC5.

$$S_{CIC5} = \text{ceil}\left(\log_2(M_{CIC5}^5 \times OL_{rCIC2})\right) - 5$$

$$OL_{CIC5} = \frac{(M_{CIC5}^5)}{2^{S_{CIC5}+5}} \times OL_{rCIC2} \quad (11)$$

The output rate of this stage is given by Equation 12.

$$f_{SAMP5} \leq \frac{f_{SAMP2}}{M_{CIC5}} \quad (12)$$

CIC5 Rejection

Table IV illustrates the amount of bandwidth in percentage of the clock rate that can be protected with various decimation rates and alias rejection specifications. The maximum input rate into the CIC5 is 80 MHz when the rCIC2 decimates by one. As in Table III, these are the 1/2 bandwidth characteristics of the CIC5. Note that the CIC5 stage can protect a much wider band than the CIC2 for any given rejection.

Table IV. SSB CIC5 Alias Rejection Table ($f_{SAMP2} = 1$)

M_{CIC5}	-50 dB	-60 dB	-70 dB	-80 dB	-90 dB	-100 dB
2	10.227	8.078	6.393	5.066	4.008	3.183
3	7.924	6.367	5.11	4.107	3.297	2.642
4	6.213	5.022	4.057	3.271	2.636	2.121
5	5.068	4.107	3.326	2.687	2.17	1.748
6	4.267	3.463	2.808	2.27	1.836	1.48
7	3.68	2.989	2.425	1.962	1.588	1.281
8	3.233	2.627	2.133	1.726	1.397	1.128
9	2.881	2.342	1.902	1.54	1.247	1.007
10	2.598	2.113	1.716	1.39	1.125	0.909
11	2.365	1.924	1.563	1.266	1.025	0.828
12	2.17	1.765	1.435	1.162	0.941	0.76
13	2.005	1.631	1.326	1.074	0.87	0.703
14	1.863	1.516	1.232	0.998	0.809	0.653
15	1.74	1.416	1.151	0.932	0.755	0.61
16	1.632	1.328	1.079	0.874	0.708	0.572
17	1.536	1.25	1.016	0.823	0.667	0.539
18	1.451	1.181	0.96	0.778	0.63	0.509
19	1.375	1.119	0.91	0.737	0.597	0.483
20	1.307	1.064	0.865	0.701	0.568	0.459
21	1.245	1.013	0.824	0.667	0.541	0.437
22	1.188	0.967	0.786	0.637	0.516	0.417
23	1.137	0.925	0.752	0.61	0.494	0.399
24	1.09	0.887	0.721	0.584	0.474	0.383
25	1.046	0.852	0.692	0.561	0.455	0.367
26	1.006	0.819	0.666	0.54	0.437	0.353
27	0.969	0.789	0.641	0.52	0.421	0.34
28	0.934	0.761	0.618	0.501	0.406	0.328
29	0.902	0.734	0.597	0.484	0.392	0.317
30	0.872	0.71	0.577	0.468	0.379	0.306
31	0.844	0.687	0.559	0.453	0.367	0.297
32	0.818	0.666	0.541	0.439	0.355	0.287

This table helps to calculate an upper bound on decimation, M_{CIC5} , given the desired filter characteristics.

RAM COEFFICIENT FILTER

The final signal processing stage is a sum-of-products decimating filter with programmable coefficients (see Figure 27). The data memories I-RAM and Q-RAM store the 160 most recent complex samples from the previous filter stage with 20-bit resolution. The coefficient memory, CMEM, stores up to 256 coefficients with 20-bit resolution. On every CLK cycle, one tap for I and one tap for Q are calculated using the same coefficients. The RCF output consists of 24-bit data bits.

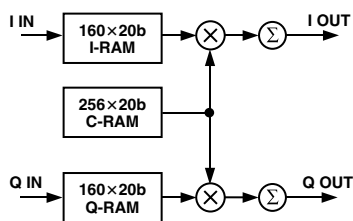

Figure 27. RAM Coefficient Filter Block Diagram

RCF Decimation Register

Each RCF channel can be used to decimate the data rate. The decimation register is an 8-bit register and can decimate from 1 to 256. The RCF decimation is stored in 0xA0 in the form of $M_{RCF}-1$. The input rate to the RCF is f_{SAMP5} .

RCF Decimation Phase

The RCF decimation phase can be used to synchronize multiple filters within a chip. This is useful when using multiple channels within the AD6624A to implement polyphase filter allowing the resources of several filters to be operated in parallel and shared. In such an application, two RCF filters would be processing the same data from the CIC5. However, each filter will be delayed by one-half the decimation rate, thus creating a 180° phase difference between the two halves. The AD6624A filter channel uses the value stored in this register to preload the RCF counter. Therefore, instead of starting from 0, the counter is loaded with this value, thus creating an offset in the processing that should be equivalent to the required processing delay. This data is stored in 0xA1 as an 8-bit number.

RCF Filter Length

The maximum number of taps this filter can calculate, N_{TAPS} , is given by the equation below. The value $N_{TAPS}-1$ is written to the channel register within the AD6624A at address 0xA2.

$$N_{TAPS} \leq \min \left[\frac{f_{CLK} \times M_{RCF}}{f_{SAMP5}}, 160 \right] \quad (13)$$

The RCF coefficients are located in addresses 0x00 to 0x7F and are interpreted as 20-bit two's-complement numbers. When writing the coefficient RAM, the lower addresses will be multiplied by relatively older data from the CIC5, and the higher coefficient addresses will be multiplied by relatively newer data from the CIC5. The coefficients need not be symmetric and the coefficient length, N_{TAPS} , may be even or odd. If the coefficients are symmetric, both sides of the impulse response must be written into the coefficient RAM.

Although the base memory for coefficients is only 128 words long, the actual length is 256 words long. There are two pages, each of 128 words long. The page is selected by Bit 8 of 0xA4. Although this data must be written in pages, the internal core handles filters that exceed the length of 128 taps. Therefore, the full length of the data RAM may be used as the filter length (160 taps).

The RCF stores the data from the CIC5 into a 160×40 RAM. 160×20 is assigned to I data and 160×20 is assigned to Q data. The RCF uses the RAM as a circular buffer, so that it is difficult to know in which address a particular data element is stored. To avoid start-up transients due to undefined data RAM values, the data RAM should be cleared upon initialization.

When the RCF is triggered to calculate a filter output, it starts by multiplying the oldest value in the data RAM by the first coefficient, which is pointed to by the RCF Coefficient Offset Register (0xA3). This value is accumulated with the products of newer data words multiplied by the subsequent locations in the coefficient RAM until the coefficient address $RCF_{OFF} + N_{TAPS} - 1$ is reached.

Table V. Three-Tap Filter

Coefficient Address	Impulse Response	Data
0	$h(0)$	N(0) Oldest
1	$h(1)$	N(1)
2 ($N_{TAPS} - 1$)	$h(2)$	N(2) Newest

The RCF Coefficient Offset register can be used for two purposes. The main purpose of this register is to allow multiple filters to be loaded into memory and selected simply by changing the offset as a pointer for rapid filter changes. The other use of this register is to form part of symbol timing adjustment. If the desired filter length is padded with zeros on the ends, the starting point can be adjusted to form slight delays when the filter is computed with reference to the high-speed clock. This allows for vernier adjustment of the symbol timing. Course adjustments can be made with the RCF Decimation Phase.

The output rate of this filter is determined by the output rate of the CIC5 stage and M_{RCF} .

$$f_{SAMPR} = \frac{f_{SAMP5}}{M_{RCF}} \quad (14)$$

RCF Output Scale Factor and Control Register

Register 0xA4 is a compound register used to configure several aspects of the RCF register. Bits 3–0 are used to set the scale of the fixed-point output mode. This scale value may also be used to set the floating-point outputs in conjunction with Bit 6 of this register.

Bits 4 and 5 determine the output mode. Mode 00 sets up the chip in fixed-point mode. The number of bits is determined by the serial port configuration. See Serial Output Data Port section.

Mode 01 selects floating-point mode 8 + 4. In this mode, an 8-bit mantissa is followed by a 4-bit exponent. In mode 1x (x is don't care), the mode is 12 + 4, or 12-bit mantissa and 4-bit exponent.

Table VI. Output Mode Formats

Floating Point 12 + 4	1x
Floating Point 8 + 4	01
Fixed Point	00

Normally, the AD6624A will determine the exponent value that optimizes numerical accuracy. However, if Bit 6 is set, the value stored in Bits 3–0 is used to scale the output. This ensures consistent scaling and accuracy during conditions that may warrant predictable output ranges.

If Bit 7 is set, the same exponent will be used for both the real and imaginary (I and Q) outputs. The exponent used will be the one that prevents numeric overflow at the expense of small signal accuracy. However, this is seldom a problem as small numbers would represent 0 regardless of the exponent used.

AD6624A

Bit 8 is the RCF bank select bit used to program the register. When this bit is 0, the lowest block of 128 is selected (Taps 0 through 127). When high, the highest block is selected (Taps 128 through 255). It should be noted that while the chip is computing filters, Tap 127 is adjacent to 128 and there are no paging issues.

Bit 9 selects the origin of the input to each RCF. If Bit 9 is clear, the RCF input comes from the CIC5 normally associated with the RCF. If, however, the bit is set, the input comes from CIC5 Channel 1. The only exception is Channel 1, which uses the output of CIC5 Channel 0 as its alternate. Using this feature, each RCF can either operate on its own channel data or be paired with the RCF of Channel 1. The RCF of Channel 1 can also be paired with Channel 0. This control bit is used with polyphase distributed filtering.

If Bit 10 is clear, the AD6624A channel operates in normal mode. However, if Bit 10 is set, the RCF is bypassed to Channel BIST. See BIST (Built In Self-Test) section below for more details.

USER-CONFIGURABLE BUILT-IN SELF-TEST (BIST)

The AD6624A includes two built-in test features to test the integrity of each channel. The first is a RAM BIST, which is intended to test the integrity of the high-speed random access memory within the AD6624A. The second is Channel BIST, which is designed to test the integrity of the main signal paths of the AD6624A. Each BIST function is independent of the other, meaning that each channel can be tested independently at the same time.

RAM BIST

The RAM BIST can be used to validate functionality of the on-chip RAM. This feature provides a simple pass/fail test, which will give confidence that the channel RAM is operational. The following steps should be followed to perform this test.

- The channels to be tested should be put into Sleep mode via the external address register 0x011.
- The RAM BIST Enable bit in the RCF register xA8 should be set high.
- Wait 1600 clock cycles.
- Register 0xA8 should be read back. If Bit 0 is high, the test is not yet complete. If Bit 0 is low, the test is complete and Bits 1 and 2 indicate the condition of the internal RAM. If Bit 1 is high, CMEM is bad. If Bit 2 is high, DMEM is bad.

Table VII. BIST Register 0xA8

Register Value	Coefficient MEM	Data MEM
XX1	Test Incomplete	Test Incomplete
000	Pass	Pass
010	Fail	Pass
100	Pass	Fail
110	Fail	Fail

CHANNEL BIST

The Channel BIST is a thorough test of the selected AD6624A signal path. With this test mode, it is possible to use externally supplied vectors or an internal pseudo-random generator. An error signature register in the RCF monitors the output data of the channel and is used to determine if the proper data exits the RCF. If errors are detected, each internal block may be bypassed and another test can be run to debug the fault. The I and Q paths are tested independently. The following steps should be followed to perform this test.

- The channels to be tested should be configured as required for the application setting the decimation rates, scalars, and RCF coefficients.
- The channels should remain in the Sleep mode.
- The Start Hold-Off counter of the channels to be tested should be set to 1.
- Memory location 0xA5 and 0xA6 should be set to 0.
- The Channel BIST located at 0xA7 should be enabled by setting Bits 19–0 to the number of RCF outputs to observe.
- Bit 4 of external address register 5 should be set high to start the soft sync.
- Set the SYNC bits high for the channels to be tested.
- Bit 6 must be set to 0 to allow the user to provide test vectors. The internal pseudo-random number generator may also be used to generate an input sequence by setting Bit 7 high.
- An internal –FS sine can be inserted when Bit 6 is set to 1 and Bit 7 is cleared.
- When the SOFT_SYNC is addressed, the selected channels will come out of the Sleep mode and processing will occur.
- If the user is providing external vectors, the chip may be brought out of Sleep mode by one of the other methods, provided that either of the IEN inputs is inactive until the channel is ready to accept data.
- After a sufficient amount of time, the Channel BIST Signature registers 0xA5 and 0xA6 will contain a numeric value that can be compared to the expected value for a known good AD6624A with the exact same configuration. If the values are the same, there is a very low probability that there is an error in the channel.

CHIP SYNCHRONIZATION

Two types of synchronization can be achieved with the AD6624A. These are Start and Hop. Each is described in detail below. The synchronization is accomplished with the use of a shadow register and a hold-off counter. See Figure 28 for a simplistic schematic of the NCO shadow register and NCO Freq Hold-Off counter to understand basic operation. Enabling the clock (AD6624A CLK) for the hold-off counter can occur with either a Soft_Sync (via the microport), or a Pin Sync (via any of the four AD6624A SYNC Pins A, B, C, and D). The functions that include shadow registers to allow synchronization include:

1. Start
2. Hop (NCO Frequency)

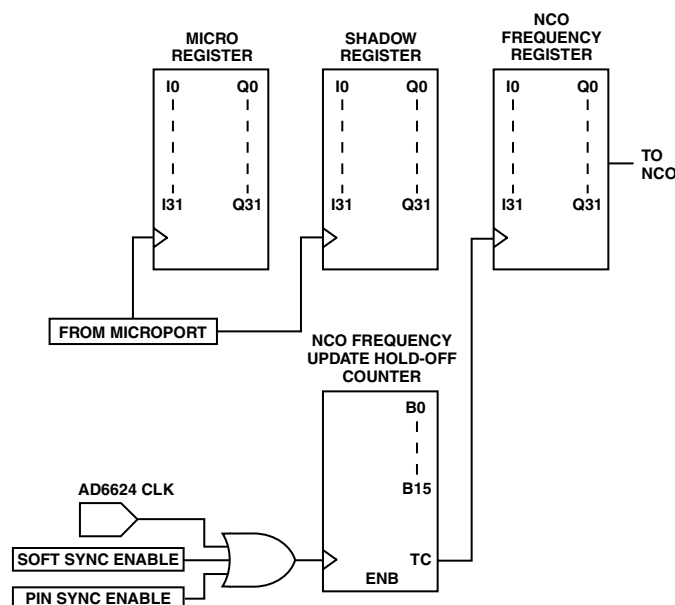

Figure 28. NCO Shadow Register and Hold-Off Counter

Start

Start refers to the start-up of an individual channel, chip, or multiple chips. If a channel is not used, it should be put in the Sleep mode to reduce power dissipation. Following a hard reset (low pulse on the AD6624A $\overline{\text{RESET}}$ pin), all channels are placed in the Sleep mode. Channels may also be manually put to sleep by writing to the mode register controlling the sleep function.

Start with No Sync

If no synchronization is needed to start multiple channels or multiple AD6624s, the following method should be used to initialize the device.

1. To program a channel, it should first be set to Sleep mode (bit high) (Ext Address 3). All appropriate control and memory registers (filter) are then loaded. The Start Update Hold-Off Counter (0x83) should be set to 1.
2. Set the appropriate Sleep bit low (Ext Address 3). This enables the channel. The channel must have Sleep mode low to activate a channel.

Start with Soft Sync

The AD6624A includes the ability to synchronize channels or chips under microprocessor control. One action to synchronize is the start of channels or chips. The Start Update Hold-Off Counter (0x83), in conjunction with the Start bit and Sync bit (Ext Address 5), allows this synchronization. Basically, the Start Update Hold-Off Counter delays the Start of a channel(s) by its value (number of AD6624A CLKs). The following method is used to synchronize the start of multiple channels via microprocessor control.

1. Set the appropriate channels to Sleep mode (a hard reset to the AD6624A Reset pin brings all four channels up in Sleep mode).
2. Note that the time RDY (Pin 57) goes high to when the NCO begins processing data is the contents of the Start Update Hold-Off Counter(s) (0x83) plus six master clock cycles.

3. Write the Start Update Hold-Off Counter(s) (0x83) to the appropriate value (greater than 1 and less than 2^{16-1}). If the chip(s) is not initialized, all other registers should be loaded at this step.
4. Write the Start bit and the Sync bit high (Ext Address 5).
5. This starts the Start Update Hold-Off Counter counting down. The counter is clocked with the AD6624A CLK signal. When it reaches a count of one, the Sleep bit of the appropriate channel(s) is set low to activate the channel(s).

Start with Pin Sync

The AD6624A has four Sync pins, A, B, C, and D, that can be used to provide for very accurate synchronization channels. Each channel can be programmed to look at any of the four sync pins. Additionally, any or all channels can monitor a single Sync pin or each can monitor a separate pin, providing complete flexibility of synchronization. Synchronization of Start with one of the external signals is accomplished with the following method.

1. Set the appropriate channels to Sleep mode (a hard reset to the AD6624A $\overline{\text{RESET}}$ pin brings all four channels up in Sleep mode).
2. Note that the time from when the SYNC pin goes high to when the NCO begins processing data is the contents of the Start Update Hold-Off Counter(s) (0x83) plus three master clock cycles.
3. Write the Start Update Hold-Off Counter(s) (0x83) to the appropriate value (greater than 1 and less than 2^{16-1}). If the chip(s) is not initialized, all other registers should be loaded at this step.
4. Set the Start on Pin Sync bit and the appropriate Sync Pin Enable high (Ext Address 4) (A, B, C, or D).
5. When the Sync pin is sampled high by the AD6624A CLK, it enables the count-down of the Start Update Hold-Off Counter. The counter is clocked with the AD6624A CLK signal. When it reaches a count of one, the Sleep bit of the appropriate channel(s) is set low to activate the channel(s).

Hop

Hop is a jump from one NCO frequency to a new NCO frequency. This change in frequency can be synchronized via microprocessor control (Soft Sync) or an external Sync signal (Pin Sync) as described below.

To set the NCO frequency without synchronization the following method should be used.

Set Freq No Hop

1. Set the NCO Freq Hold-Off counter to 0.
2. Load the appropriate NCO frequency. The new frequency will be immediately loaded to the NCO.

Hop with Soft Sync

The AD6624A includes the ability to synchronize a change in NCO frequency of multiple channels or chips under microprocessor control. The NCO Freq Hold-Off counter (0x84), in conjunction with the Hop bit and the Sync bit (Ext Address 4), allow this synchronization. Basically, the NCO Freq Hold-Off counter delays the new frequency from being loaded into the NCO by its value (number of AD6624A CLKs). The following method is used to synchronize a hop in frequency of multiple channels via microprocessor control.

AD6624A

1. Note that the time from when RDY (Pin 57) goes high to when the NCO begins processing data is the contents of the NCO Freq Hold-Off counter (0x84) plus seven master clock cycles.
2. Write the NCO Freq Hold-Off (0x84) counter to the appropriate value (greater than 1 and less than 2^{16-1}).
3. Write the NCO Frequency register(s) to the new desired frequency.
4. Write the Hop bit and the Sync(s) bit high (Ext Address 4).
5. This starts the NCO Freq Hold-Off counter counting down. The counter is clocked with the AD6624A CLK signal. When it reaches a count of one, the new frequency is loaded into the NCO.

Hop with Pin Sync

The AD6624A includes four Sync pins to provide the most accurate synchronization, especially between multiple AD6624s. Synchronization of hopping to a new NCO frequency with an external signal is accomplished using the following method:

1. Note that the time from when the Sync pin goes high to when the NCO begins processing data is the contents of the NCO Freq Hold-Off counter (0x84) plus five master clock cycles.
2. Write the NCO Freq Hold-Off counter(s) (0x84) to the appropriate value (greater than 1 and less than 2^{16-1}).
3. Write the NCO Frequency register(s) to the new desired frequency.
4. Set the Hop on Pin Sync bit and the appropriate Sync Pin Enable high.
5. When the selected Sync pin is sampled high by the AD6624A CLK, it enables the count-down of the NCO Freq Hold-Off counter. The counter is clocked with the AD6624A CLK signal. When it reaches a count of one, the new frequency is loaded into the NCO.

SERIAL OUTPUT DATA PORT

The AD6624A has four configurable serial output ports (SDO0, SDO1, SDO2, and SDO3). Each port can be operated independently of the other, making it possible to connect each to a different DSP. In the case where a single DSP is required, the ports can easily be configured to work with a single serial port on a single DSP. As such, each output may be configured as either serial master or slave. Additionally, each channel can be configured independently of the others.

Serial Output Data Format

The AD6624A works with a variety of output data formats. These include word lengths of 12-, 16-, and 24-bit precision. In addition to the normal linear binary data format, the AD6624A offers a floating-point data format to simplify numeric processing. These formats are 8-bit mantissa with 4-bit exponent, and 12-bit mantissa and 4-bit exponent. These modes are available regardless of the bit precision of the serial data frame. In the normal linear binary data format, a programmable internal 4-bit scaling factor is used to scale the output. See the RCF Output Scale Factor section and Control Register above for more details. In all modes, the data is shifted out of the device in Big Endian format (MSB first).

In floating-point mode, the chip normally determines the exponent automatically; however, the chip can be forced to use the same exponent for both the real and imaginary portion of the data. The choice of exponents favors prevention of numerical overflow at the expense of small number accuracy. However, this should not be a problem as small numbers imply numbers close to zero.

Finally, the AD6624A channel can be forced to use a preselected scale factor if desired. This allows for a consistent range of data useful to many applications.

Compact Serial Data Format

Channel data from the AD6624A can be output in a compact 8+4 floating-point format in conjunction with the Common Exponent model. The 8+4 floating-point format causes the AD6624A to provide I/Q output data in the form [I mantissa, 8 bits] [I exponent, 4 bits] followed by [Q mantissa, 8 bits] [Q exponent, 4 bits]. Although the four Q exponent bits normally would follow the Q mantissa, it is not strictly necessary for these bits to be provided since its value will be identical to the I exponent value due to the Common Exponent mode. Since the next I/Q sample appears internally at the shifter after precisely 20 high-speed clock cycles, the four Q exponent bits are not shifted out. (The output shifter gives priority to the new sample rather than the four remaining exponent bits.) The result is that 20 bits are provided as necessary, and these bits contain all the information necessary to reconstruct the I/Q sample. Note that all output shifters will be continuously active with this configuration.

The compact serial data mode is enabled by using a total decimation factor of 20 in each channel. The equation below illustrates how decimation and interpolation factors can be distributed across the filter blocks:

$$\frac{M_{rCIC2}}{L_{rCIC2}} \times M_{rCIC5} \times M_{RCF} = 20 \quad (15)$$

The RCF control register must also be set to 8+4 floating-point mode (0xA4 bits 5-4: 01), and the common exponent mode (0xA4 bit 7: 1). For more information on how the Compact Serial Data Format can be used to process UMTS signals, please reference the technical note: Processing Two UMTS Carriers with 2x Oversampling Using the AD6624A.

Serial Data Frame (Serial Bus Master)

The serial data frame is initiated with the Serial Data Frame Sync (SDFS0, SDFS1, SDFS2, or SDFS3). As each channel within the AD6624A completes a filter cycle, data is transferred into the serial data buffer. In the Serial Bus Master (SBM) mode, the internal serial controller initiates the SDFS on the next rising edge of the serial clock. In the AD6624A, there are three different modes in which the frame sync may be generated as a Serial Bus Master.

In the first mode, the SDFS is valid for one complete clock cycle prior to the data shift. On the next clock cycle, the AD6624A begins shifting out the digitally processed data stream. Depending on the bit precision of the serial configuration, either 12, 16, or 24 bits of I data are shifted out, followed by 12, 16, or 24 bits of Q data. The format of this data will be in one of the formats listed above. In the second mode, the SDFS is high for the entire time that valid bits are being shifted. The SDFS bit goes high concurrent with the first bit shifted out of the AD6624A.

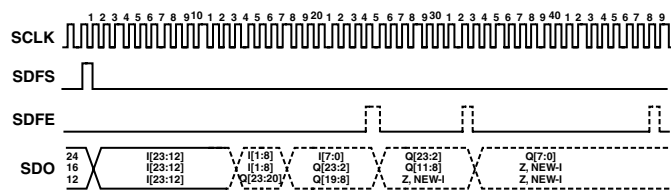

Figure 29. SDFS Valid for One SCLK Cycle

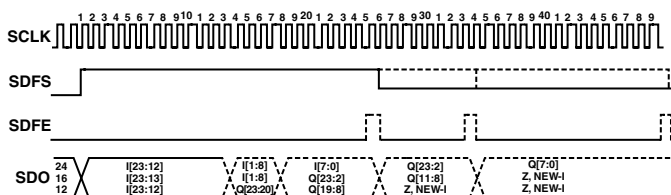

Figure 30. SDFS Is High During Data Shift

In the final mode, the SDFS bit goes high as in the first mode, one clock cycle prior to the actual data. However, a second SDFS is inserted one clock cycle prior to the shift of the first Q bit. In this manner, each word out of the AD6624A is accompanied by an SDFS.

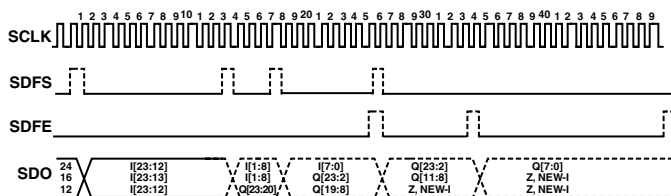

Figure 31. A Second SDFS Inserted Prior to First Q Bit

Regardless of the mode above, the SDFE behaves the same in each. On the last bit of the serial frame (least significant bit of the Q word), the Serial Data Frame End (SDFE) is raised. The SDFE signal can either be used by the DSP to indicate the end of the frame or it can be used as the SDFS (Serial Data Frame Sync) of another AD6624A chip or channel running in Serial Cascade mode.

Serial Data Frame (Serial Cascade)

Any of the AD6624A serial outputs may be operated in the serial cascade mode (serial slave). In this mode, the selected AD6624A channel requires an external device such as a DSP to issue the serial clock and SDFS.

To operate successfully in the serial cascade mode, the DSP must have some indication that the AD6624A channel's serial buffer is ready to send data. This is indicated by the assertion of the DR_x pin where "x" is the channel number. This pin should be tied to an interrupt or flag pin of the DSP. In this manner, the DSP will know when to service the serial port.

When the DSP begins handling the serial service, the serial port should be configured such that the SDFS pin is asserted one clock cycle prior to shifting data. As such, the AD6624A channel samples the SDFS pin on the rising edge of the serial clock. On the next rising edge of the serial clock, the AD6624A serial port begins shifting data until the specified number of bits has been shifted.

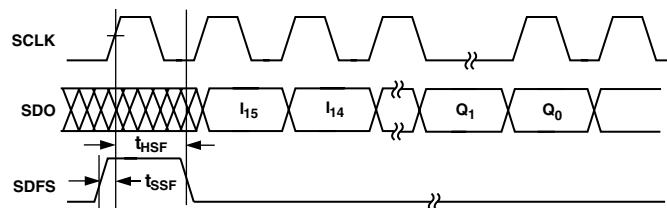

Figure 32. SDO, SDFS Switching Characteristics (SBM = 0)

On the last bit of the serial frame (least significant bit of the Q word), the SDFE is raised. The SDFE signal can either be used by the DSP to indicate the end of the frame or it can be used as the SDFS of another AD6624A chip or channel running in Serial Cascade mode.

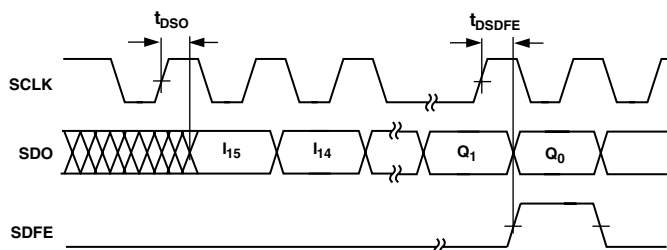

Figure 33. SDO, SDFE Switching Characteristics

Configuring the Serial Ports

Each Serial Output Port may function as either a master or slave. A Serial Bus Master will provide SCLK (SCLK0, SCLK1, SCLK2, SCLK3) and SDFS outputs. A Serial Slave will accept these signals as inputs. Upon the lift of RESET, Serial Port 0 will become a master if the SBM0 pin is high, and a slave if SBM0 is low. Serial Ports 1, 2, and 3 will always default to serial slaves when RESET is taken low. They can be programmed as a master by setting the SBM1, SBM2, and SBM3 bits in the 0xA9 Registers high.

Serial Port Data Rate

If a Serial Port is defined as a master, the SCLK frequency is defined by Equation 15. f_{CLK} is the frequency of the master clock of the AD6624A channel and SDIV is the Serial Division word for the channel (1, 2, or 3). The SDIV for Serial Port 0 is located directly as pins on the package for easy hardware configuration and is *not* mapped into 0xA9. For Serial Ports 1, 2, and 3, the internal register 0xA9 Bits 3–0 define the SDIV (SDIV0, SDIV1, SDIV2, SDIV3) word.

$$f_{SCLK} = \frac{f_{CLK}}{SDIV + 1} \quad (16)$$

Serial Port to DSP Interconnection

The AD6624A is very flexible in the manner that the serial ports can be configured and connected to external devices. Each of the channels can be independently configured and processed by different DSPs or all of the channels can be chained together to form a TDM (time division multiplexed) serial chain. This allows one DSP to handle all of the channels. Additionally, the channels can be parceled off in any combination in between.

AD6624A

To configure a channel as a serial bus master, Bit 4 of register 0xA9 should be set high. However, as with the SDIV pins, Channel 0 SBM is not mapped to memory and is instead pinned out and must be hard-wired as either a master or a slave. Figure 34 shows the typical interconnections between an AD6624A Channel in Serial Bus Master mode and a DSP.

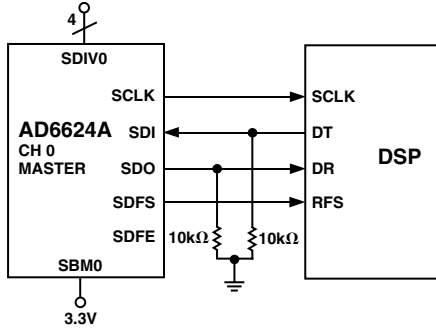

Figure 34. Typical Serial Data Output Interface to DSP (Serial Master Mode, SBM = 1)

Serial Slave Operation

The AD6624A can also be operated as a serial bus slave. In this configuration, shown in Figure 35, the serial clock provided by the DSP can be asynchronous with the AD6624A clock and input data. In this mode, the clock has a maximum frequency of 62.5 MHz and must be fast enough to read the entire serial frame prior to the next frame coming available. Since the AD6624A output is derived (via the Decimation/Interpolation Rates) from its input sample rate, the output rate can be determined by the user. The output rate of the AD6624A is given below.

$$f_{OUT} = \frac{F_{ADC} \times L_{CIC2}}{M_{CIC2} \times M_{CIC5} \times M_{RCF}} \quad (17)$$

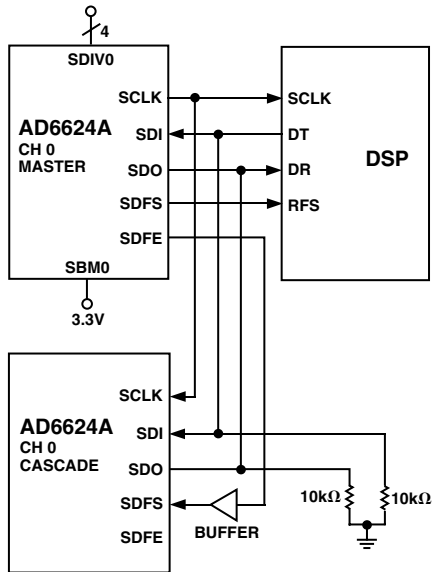

Figure 35. Typical Serial Data Output Interface to DSP (Serial Slave Mode, SBM = 0)

Serial Ports Cascaded

Serial output ports may be cascaded on the AD6624A such that the SDO's outputs are shorted together. In this mode, the SDO port of the master channel three-states when the SDO port of the slave channel is active. This allows data to be shifted out of a slave channel immediately following the completion of data frame (I/Q pair) shifting out of a master AD6624A channel. To accomplish this, the SDFE signal of the master channel drives the SDFS input of the slave channel. Serial output port cascading can be used with channels on the same AD6624A device, or with channels on two different devices as shown in Figure 36. To satisfy t_{SSF} and t_{HSF} timing requirements of the slave channel, the SDFE signal from the master channel should be delayed using a noninverting buffer (e.g., 74LVC244A) that provides a minimum of 1.5 ns of propagation delay. Figure 36 shows the cascade capability between two AD6624A devices. The first is connected as a serial master (SBM = 1) and the second is configured in Serial Cascade mode (SBM = 0).

Using the AD6624A master/slave mode permits a DSP to shift the data from the master AD6624A serial port, followed immediately by a frame of data (I and Q words) from the AD6624A slave port. As shown in Figure 36, the master port is Serial Port 0. The slave port can be either Serial Port 1, 2, or 3, or a Serial Port 0 from another AD6624A. Other AD6624A serial ports can be cascaded to the slave port by using the SDFE and SDFS in the manner shown. The only limit to the number of ports that can be cascaded comes from serial bandwidth and fan-out considerations.

There must be enough serial clock cycles available to shift the necessary data into the DSP, and the SCLK (common to all channels and DSP) must be closely monitored to ensure that it is a clean signal. For systems where a single DSP serial port will be connected to many AD6624A serial ports, it is recommended that the SCLK signal from the master be buffered to the slaves. See Serial Port Buffering in the Applications section.

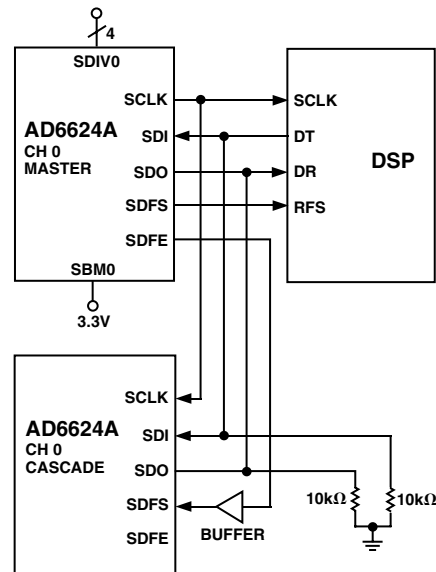

Figure 36. Typical Serial Data Output Interface to DSP (Serial Cascade Mode, SBM = 0)

Table VIII. Channel Address Memory Map

Ch Address	Register	Bit Width	Comments
00–7F	Coefficient Memory (CMEM)	20	128 × 20-Bit Memory
80	CHANNEL SLEEP	1	0: SLEEP Bit from EXT_ADDRESS 3
81	Soft_Sync Control Register	2	1: Hop 0: Start
82	Pin_SYNC Control Register	3	2: First SYNC Only 1: Hop_En 0: Start_En
83	Start Hold-Off Counter	16	Start Hold-Off Value
84	NCO Frequency Hold-Off Counter	16	NCO_FREQ Hold-Off Value
85	NCO Frequency Register 0	16	NCO_FREQ[15:0]
86	NCO Frequency Register 1	16	NCO_FREQ[31:16]
87	NCO Phase Offset Register	16	NCO_PHASE[15:0]
88	NCO Control Register	9	8–7: SYNC Input Select[1:0] 6: WB Input Select B/A 5–4: Input Enable Control 11: Clock On IEN Transition to Low 10: Clock On IEN Transition to High 01: Clock On IEN High 00: Mask On IEN Low 3: Clear Phase Accumulator On HOP 2: Amplitude Dither 1: Phase Dither 0: Bypass (A-Input -> I-Path, B -> Q)
89–8F	Unused		
90	rCIC2 Decimation – 1	12	$M_{rCIC2}-1$
91	rCIC2 Interpolation – 1	9	$L_{rCIC2}-1$
92	rCIC2 Scale	12	11: Exponent Invert 10: Exponent Weight 9–5: rCIC2_QUIET[4:0] 4–0: rCIC2_LOUD[4:0]
93	Reserved	8	Reserved (Must Be Written Low)
94	CIC5 Decimation –1	8	$M_{CIC5}-1$
95	CIC5 Scale	5	4–0: CIC5_SCALE[4:0]
96	Reserved	8	Reserved (Must Be Written Low)
97–9F	Unused		
A0	RCF Decimation – 1	8	$M_{RCF}-1$
A1	RCF Decimation Phase	8	P_{RCF}
A2	RCF Number of Taps –1	8	$N_{TAPS}-1$
A3	RCF Coefficient Offset	8	CO_{RCF}
A4	RCF Control Register	11	10: RCF Bypass BIST 9: RCF Input Select (Own 0, Other 1) 8: Program RAM Bank 1/0 7: Use Common Exponent 6: Force Output Scale 5–4: Output Format 1x: Floating Point 12 + 4 01: Floating Point 8 + 4 00: Fixed Point 3–0: Output Scale

Table VIII. Channel Address Memory Map (continued)

Ch Address	Register	Bit Width	Comments
A5	BIST Signature for I Path	16	BIST-I
A6	BIST Signature for Q Path	16	BIST-Q
A7	# of BIST Outputs to Accumulate	20	19-0: # of Outputs (Counter Value Read)
A8	RAM BIST Control Register	3	2: D-RAM Fail/Pass 1: C-RAM Fail/Pass 0: RAM BIST Enable
A9	Serial Port Control Register	10	9: Map RCF Data to BIST Registers 8-7: I_SDFS Control 1x: Separate I and Q SDFS Pulses 01: SDFS High for Entire Frame 00: Single SDFS Pulse 6-5: SOWL 1x: 24-Bit Words 01: 16-Bit Words 00: 12-Bit Words 4: SBM _x 3-0: SDIV _x [3:0]

Serial Output Frame Timing (Master and Slave)

The SDFS signal transitions accordingly depending on whether the part is in Master (SBM = 1, Figure 43) or Slave (SBM = 0, Figure 32) mode. The next rising edge of SCLK after this occurs will drive the first bit of the serial data on the SDO pin. The falling edge of SCLK or the subsequent rising edge can then be used by the DSP to sample the data until the required number of bits is received (determined by the serial output port word length). If the DSP has the ability to count bits, the DSP will know when the complete frame is received. If not, the DSP can monitor the SDFE pin to determine that the frame is complete.

Serial Port Timing Specifications

Whether the AD6624A serial channel is operated as a Serial Bus Master or as a Serial Slave, the serial port timing is identical. Figures 38 to 44 indicate the required timing for each of the specifications.

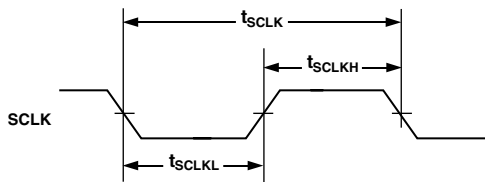

Figure 37. SCLK Timing Requirements

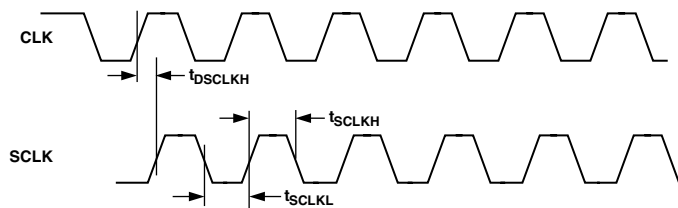

Figure 38. SCLK Switching Characteristics (Divide by 1)

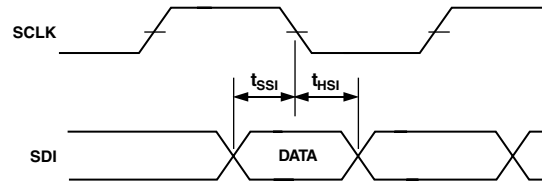

Figure 39. Serial Input Data Timing Requirements

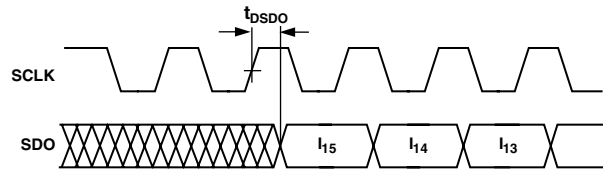

Figure 40. Serial Output Data Switching Characteristics

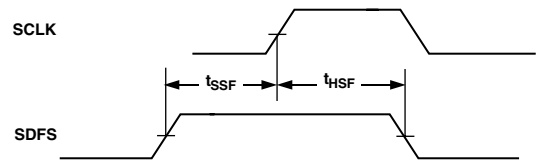

Figure 41. SDFS Timing Requirements (SBM = 0)

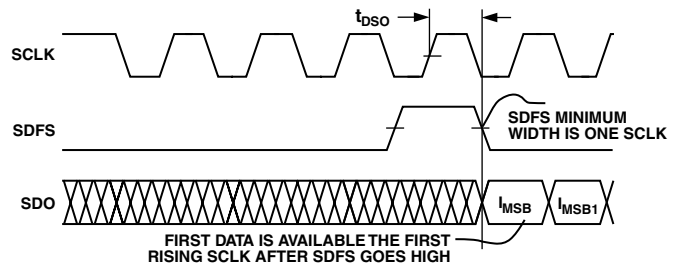

Figure 42. Timing for Serial Output Port (SBM = 1)

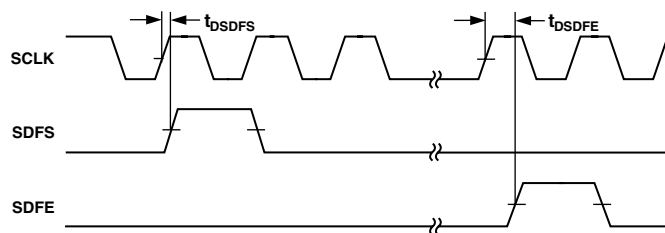

Figure 43. Serial Frame Switching Characteristics (SBM = 1)

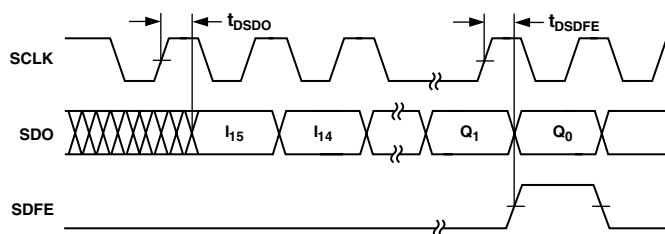

Figure 44. SDO, SDFE Switching Characteristics

SBM0

SBM0 is the Serial Bus Master pin for the Channel 0 Serial Port only. Serial Ports 1, 2, and 3 will always default to Serial Slave mode but can be programmed as masters in the internal register space. The SBM0 pin gives the user the option to boot the AD6624A through Serial Port 0 as a master. When SBM0 is high (master mode), the AD6624A generates SCLK0 and SDFS0. When SBM0 is low (slave mode), the AD6624A accepts external SCLK0 and SDFS0 signals. When configured as a bus master, the SCLK0 signal can be used to strobe data into the DSP interface. When used with another AD6624A in Serial Cascade mode, SCLK0 can be taken from the master AD6624A and used to shift data out from the cascaded device. In this situation, SDFS of the slave AD6624A channel is connected to the SDFE pin of the master AD6624A channel (or the preceding chip in the chain). When an AD6624A is in Serial Slave mode, all of the serial port activities are controlled by the external signals SCLK and SDFS.

Regardless of whether the chip is a Serial Bus Master or is in Serial Slave mode, the AD6624A Serial Port functions are identical except for the source of the SCLK and SDFS pins.

SCLK

SCLK is an output when SBM (SBM0 or register bit for Serial Ports 1, 2, and 3) is high; SCLK is an input when SBM (SBM0 or register bit for Serial Ports 1, 2, and 3) is low in serial slave mode. In either case, the SDIN input is sampled on the falling edge of SCLK and all outputs are switched on the rising edge of SCLK. The SDFS pin is sampled on the falling edge of SCLK. This allows the AD6624A to recognize the SDFS in time to initiate a frame on the very next SCLK rising edge. The maximum speed of this port is 80 MHz.

SDIN

SDIN is the Serial Data Input. Serial Data is sampled on the falling edge of SCLK. This pin is used in the serial control mode to write the internal control registers of the AD6624A. These activities are described later in the Serial Port Control section. The Serial Input Port is self-framing and bears no fixed relationship to either SDFS or SDFE.

SDO

SDO is the Serial Data Output. Serial output data is shifted on the rising edge of SCLK. On the very next SCLK rising edge after an SDFS, the MSB of the I data from the channel is shifted. On every subsequent SCLK edge, a new piece of data is shifted out on the SDO pin until the last bit of data is shifted out. The last bit of data shifted is the LSB of the Channel's Q data. SDO is three-stated when the serial port is outside its time-slot. This allows the AD6624A to share the SDIN of a DSP with other AD6624As or other devices.

SDFS

SDFS is the Serial Data Frame Sync signal. SDFS is an output when SBM (SBM0 or register bit for Serial Ports 1, 2, and 3) is high in the Master mode. SDFS is an input when SBM (SBM0 or register bit for Serial Ports 1, 2, and 3) is low in the Slave mode. SDFS is sampled on the falling edge of SCLK. When SBM is sampled low, the AD6624A serial port will function as a serial slave. In this mode, the port is silent until the DSP issues a frame sync. When the AD6624A detects an SDFS on the falling edge of a DSP-generated serial clock, on the next rising edge of the serial clock, the AD6624A enables the output driver and shifts the MSB of the I word. Data is shifted until the LSB of the Q word has been sent. On the LSB of the Q word, the AD6624A generates an SDFE, which can be cascaded to the next SDFS on a TDM serial chain or to the DSP to indicate that the last bit has been sent.

When SBM is sampled high, the chip functions as a serial bus master. In this mode, the AD6624A is responsible for generating serial control data. Three modes of that operation are set via channel address 0xA9 Bits 8–7. Each behaves a little differently, as detailed below.

In the first mode (0xA9 Bits 8–7:00), the SDFS is valid for one complete clock cycle prior to the data shift. On the next clock cycle, the AD6624A begins shifting serial data. In the second mode, (0xA9 Bits 8–7:01), the SDFS is high for the entire time that valid bits are being shifted. The SDFS bit goes high concurrent with the first bit shifted out of the AD6624A and returns low after the last bit is shifted out of the AD6624A. In the third mode (0xA9 Bits 8–7:10), the SDFS bit goes high as in the first mode, one clock cycle prior to the actual data. However, a second SDFS is inserted one clock cycle prior to the shift of the first Q bit. In this manner, each word out of the AD6624A is accompanied by an SDFS.

SDFE

SDFE is the Serial Data Frame End output. SDFE will go high during the last SCLK cycle (LSB of the Q word) of an active time-slot. The SDFE output of a master AD6624A channel can be tied to the input SDFS of an AD6624A channel in Serial Slave mode in order to provide a hard-wired time-slot scenario. When the last bit of SDO data is shifted out of the Master AD6624A, the SDFE signal will be driven high by the same SCLK rising edge on which this bit is clocked out. On the falling edge of this SCLK cycle, the slaved serial port will sample its SDFS signal, which is hard-wired to the SDFE of the master. On the very next SCLK rising edge, data of the slave will start shifting. There will be no rest between the time slots of the master and slave.

Serial Word Length

Bits 6–5 of register 0xA9 determine the length of the serial word (I or Q). If these bits are set to '00,' each word is 12 bits (12 bits

AD6624A

for I and 12 more bits for Q). If set to '01,' the serial words are 16 bits wide, and if set to '1x' (x is don't care), the word length is 24 bits.

SDFS Mode

Bits 8–7 of register 0xA9 determine how the SDFS behaves in Serial Bus Master mode. In Serial Slave mode, the frame sync must be formatted by programming Bits 8–7 to '00.'

The first mode is set by programming Bits 8–7 to '00'. In this mode, the SDFS is valid for one complete clock cycle prior to the data shift. On the next clock cycle, the AD6624A begins shifting out the digitally processed data stream. Depending on the bit precision of the serial configuration, either 12, 16, or 24 bits of I data are shifted out, followed by 12, 16, or 24 bits of Q data.

The second mode is set by programming Bits 8–7 to '01.' In this mode, the SDFS is high for the entire time that valid bits are being shifted. The SDFS bit goes high concurrent with the first bit shifted out of the AD6624A and goes low after the last bit has been shifted.

The third mode is set by programming Bits 8–7 to '1x' (x is don't care). In this mode, the SDFS bit goes high as in the first mode, one clock cycle prior to the actual data. However, a second SDFS is inserted one clock cycle prior to the shift of the first Q bit. In this manner, each word out of the AD6624A is accompanied by an SDFS.

Mapping RCF Data to the BIST Registers

If Bit 9 of 0xA9 is set, RCF data is routed to the BIST registers. This allows the filter results to be read from the microprocessor port. This can be useful when the data must be accessed via a parallel port and the decimation rate is sufficiently high that throughput does not become an issue.

0x00–0x7F: Coefficient Memory (CMEM)

This is the Coefficient Memory (CMEM) used by the RCF. It is memory mapped as 128 words by 20 bits. A second 128 words of RAM may be accessed via this same location by writing Bit 8 of the RCF control register high at channel address 0xA4. The filter calculated will always use the same coefficients for I and Q. By using memory from both of these 128 blocks, a filter up to 160 taps can be calculated. Multiple filters can be loaded and selected with a single internal access to the Coefficient Offset Register at channel address 0xA3.

0x80: Channel Sleep Register

This register contains the SLEEP bit for the channel. When this bit is high, the channel is placed in a low power state. When this bit is low, the channel processes data. Note that in serial slave mode, the $\overline{\text{RESET}}$ pin needs to be held low for several SCLK cycles to ensure that it will program this bit high. This bit can also be set by accessing the SLEEP register at external address 3. When the external SLEEP register is accessed, all four channels are accessed simultaneously and the SLEEP bits of the channels are set appropriately.

0x81: Soft_SYNC Register

This register is used to initiate SYNC events through the microport. If the Hop bit is written high, the Hop Hold-Off Counter at address 0x84 is loaded and begins to count down. When this value reaches one, the NCO Frequency register used by the NCO accumulator, is loaded with the data from channel addresses 0x85 and 0x86. When the Start bit is set high, the Start Hold-Off

Counter is loaded with the value at address 0x83 and begins to count down. When this value hits one, the Sleep bit in address 0x80 is dropped low and the channel is started.

0x82: Pin_SYNC Register

This register is used to control the functionality of the SYNC pins. Any of the four SYNC pins can be chosen and monitored by the channel. The channel can be configured to initiate either a Start or Hop SYNC event by setting the Hop or Start bit high. These bits function as enables so that when a SYNC pulse occurs either the Start or Hop Hold-Off Counters are activated in the same manner as with a Soft_SYNC.

0x83: Start Hold-Off Counter

The Start Hold-Off Counter is loaded with the value written to this address when a Start_Sync is initiated. It can be initiated by either a Soft_SYNC or Pin_SYNC. The counter begins decrementing and when it reaches a value of one, the channel is brought out of SLEEP and begins processing data. If the channel is already running, the phase of the filters is adjusted such that multiple AD6624s can be synchronized. A periodic pulse on the SYNC pin can be used in this way to adjust the timing of the filters with the resolution of the ADC sample clock. If this register is written to a one, the Start will occur immediately when the SYNC comes into the channel. If it is written to a zero, no SYNC will occur.

0x84: NCO Frequency Hold-Off Counter

The NCO Frequency Hold-Off Counter is loaded with the value written to this address when either a Soft_SYNC or Pin_SYNC comes into the channel. The counter begins counting down so that when it reaches one, the NCO Frequency word is updated with the values of addresses 0x85 and 0x86. This is known as a Hop or Hop_SYNC. If this register is written to a one, the NCO Frequency will be updated immediately when the SYNC comes into the channel. If it is written to a zero, no HOP will occur. NCO HOPs can be either phase continuous or nonphase continuous, depending upon the state of Bit 3 of the NCO control register at channel address 0x88. When this bit is low, the Phase Accumulator of the NCO is not cleared, but starts to add the new NCO Frequency word to the accumulator as soon as the SYNC occurs. If this bit is high, the Phase Accumulator of the NCO is cleared to zero and the new word is then accumulated.

0x85: NCO Frequency Register 0

This register represents the 16 LSBs of the NCO Frequency word. These bits are shadowed and are not updated to the register used for the processing until the channel is either brought out of SLEEP or a Soft_SYNC or Pin_SYNC has been issued. In the latter two cases, the register is updated when the Frequency Hold-Off Counter hits a value of one. If the Frequency Hold-Off Counter is set to one, the register will be updated as soon as the shadow is written.

0x86: NCO Frequency Register 1

This register represents the 16 MSBs of the NCO Frequency word. These bits are shadowed and are not updated to the register used for the processing until the channel is either brought out of SLEEP or a Soft_SYNC or Pin_SYNC has been issued. In the latter two cases, the register is updated only when the Frequency Hold-Off Counter hits a value of one. If the Frequency Hold-Off Counter is set to one, the register will be updated as soon as the shadow is written.

0x87: NCO Phase Offset Register

This register represents a 16-bit phase offset to the NCO. It can be interpreted as values ranging from 0 to just under 2π .

0x88: NCO Control Register

This 9-bit register controls features of the NCO and the channel. The bits are defined below. For more detail, the NCO section should be consulted.

Bits 8–7 of this register choose which of the four SYNC pins are used by the channel. The SYNC pin selected can be used to initiate a START, HOP, or timing adjustment to the channel. The Synchronization section of this data sheet provides more details on this.

Bit 6 of this register defines whether the A or B Input Port is used by the channel. If this bit is low, the A Input Port is selected and if this bit is high the B Input Port is selected. Each input port consists of a 14-bit input mantissa (INx[13:0]), a 3-bit exponent (EXPx[2:0]), and an input enable pin, IENx. The x represents either A or B.

Bits 5–4 determine how the sample clock for the channel is derived from the high-speed CLK signal. There are four possible choices. Each is defined below but for further detail, the NCO section of the data sheet should be consulted.

When these bits are 00, the input sample rate (f_{SAMP}) of the channel is equal to the rate of the high-speed CLK signal. When IEN is low, the data going into the channel is masked to 0. This is an appropriate mode for TDD systems where the receiver may wish to mask off the transmitted data yet still remain in the proper phase for the next receive burst.

When these bits are 01, the input sample rate is determined by the fraction of the rising edges of CLK on which the IEN input is high. For example, if IEN toggles on every rising edge of CLK, then the IEN signal will only be sampled high on one out of every two rising edges of CLK. This means that the input sample rate f_{SAMP} will be 1/2 the CLK rate.

When these bits are 10, the input sample rate is determined by the rate at which the IEN pin toggles. The data that is captured on the rising edge of CLK after IEN transitions from low to high is processed. When these bits are 11, the accumulator and sample CLK are determined by the rate at which the IEN pin toggles. The data that is captured on the rising edge of CLK after IEN transitions from high to low is processed. For example, Control Modes 10 and 11 can be used to allow interleaved data from either the A or B Input Ports and then assigned to the respective channel. The IEN pin selects the data such that a channel could be configured in Mode 10 and another could be configured in Mode 11.

Bit 3 determines whether or not the phase accumulator of the NCO is cleared when a Hop occurs. The Hop can originate from either the Pin_SYNC or Soft_SYNC. When this bit is set to 0, the Hop is phase continuous and the accumulator is not cleared. When this bit is set to 1, the accumulator is cleared to 0 before it begins accumulating the new frequency word. This is appropriate when multiple channels are hopping from different frequencies to a common frequency.

Bits 2–1 control whether or not the dithers of the NCO are activated. The use of these features is heavily determined by the system constraints. Consult the NCO section of the data sheet for more detailed information on the use of dither.

Bit 0 of this register allows the NCO Frequency translation stage to be bypassed. When this occurs, the data from the A Input Port is passed down the I path of the channel and the data from the B Input Port is passed down the Q path of the channel. This allows a real filter to be performed on baseband I and Q data.

0x90: rCIC2 Decimation – 1 ($M_{\text{rCIC2}}-1$)

This register is used to set the decimation in the rCIC2 filter. The value written to this register is the decimation minus one. The rCIC2 decimation can range from 1 to 4096 depending upon the interpolation of the channel. The decimation must always be greater than the interpolation. M_{rCIC2} must be chosen larger than L_{rCIC2} and both must be chosen such that a suitable rCIC2 Scalar can be chosen. For more details, consult the rCIC2 section.

0x91: rCIC2 Interpolation – 1 ($L_{\text{rCIC2}}-1$)

This register is used to set the interpolation in the rCIC2 filter. The value written to this register is the interpolation minus one. The rCIC2 interpolation can range from 1 to 512 depending upon the decimation of the rCIC2. There is no timing error associated with this interpolation. See the rCIC2 section of the data sheet for further details.

0x92: rCIC2 Scale

The rCIC2 scale register is used to provide attenuation to compensate for the gain of the rCIC2 and to adjust the linearization of the data from the floating-point input. The use of this scale register is influenced by both the rCIC2 growth and floating-point input port considerations. The rCIC2 section should be consulted for details. The rCIC2 scalar has been combined with the Exponent Offset and will need to be handled appropriately in both the Input Port and rCIC2 sections.

Bit 11 determines the polarity of the exponent. Normally, this bit will be cleared unless an ADC such as the AD6600 is used, in which case, this bit will be set.

Bit 10 determines the weight of the exponent word associated with the input port. When this bit is low, each exponent step is considered to be worth 6.02 dB. When this bit is high, each exponent step is considered to be worth 12.02 dB.

Bits 9–5 are the actual scale values used when the Level Indicator, LI pin associated with this channel is active.

Bits 4–0 are the actual scale values used when the Level Indicator, LI pin associated with this channel is inactive.

0x93:

Reserved. (Must be written low.)

0x94: CIC5 Decimation – 1 ($M_{\text{CIC5}}-1$)

This register is used to set the decimation in the CIC5 filter. The value written to this register is the decimation minus one. Although this is an 8-bit register, the decimation is usually limited to values between 1 and 32. Decimations higher than 32 would require more scaling than the CIC5's capability.

0x95: CIC5 Scale

The CIC5 scale factor is used to compensate for the growth of the CIC5 filter. Consult the CIC5 section for details.

0x96:

Reserved. (Must be written low.)

0xA0: RCF Decimation – 1 ($M_{\text{RCF}}-1$)

This register is used to set the decimation of the RCF stage. The value written is the decimation minus one. Although this is an 8-bit

AD6624A

register which allows decimation up to 256, for most filtering scenarios, the decimation should be limited to values between 1 and 32. Higher decimations are allowed, but the alias protection of the RCF may not be acceptable for some applications.

0xA1: RCF Decimation Phase (P_{RCF})

This register allows any one of the M_{RCF} phases of the filter to be used and can be adjusted dynamically. Each time a filter is started, this phase is updated. When a channel is synchronized, it will retain the phase setting chosen here. This can be used as part of a timing recovery loop with an external processor or can allow multiple RCFs to work together while using a single RCF pair. The RCF section of the data sheet should be consulted for further details.

0xA2: RCF Number of Taps Minus One ($N_{RCF}-1$)

The number of taps for the RCF filter minus one is written here.

0xA3: RCF Coefficient Offset (CO_{RCF})

This register is used to specify which section of the 256-word coefficient memory is used for a filter. It can be used to select among multiple filters that are loaded into memory and referenced by this pointer. This register is shadowed and the filter pointer is updated every time a new filter is started. This allows the Coefficient Offset to be written even while a filter is being computed with disturbing operation. The next sample that comes out of the RCF will be with the new filter.

0xA4: RCF Control Register

The RCF Control Register is an 11-bit register that controls general features of the RCF as well as output formatting. The bits of this register and their functions are described below.

Bit 10 bypasses the RCF filter and sends the CIC5 output data to the BIST-I and BIST-Q registers. The 16 MSBs of the CIC5 data can be accessed from this register if Bit 9 of the Serial Control Register at channel address 0xA9 is set.

Bit 9 of this register controls the source of the input data to the RCF. If this bit is 0, the RCF processes the output data of its own channel. If this bit is 1, it processes the data from the CIC5 of another channel. The CIC5 that the RCF is connected to when this bit is 1 is shown in the table below. This can be used to allow multiple RCFs to be used together to process wider bandwidth channels. See the Multiprocessing section of the data sheet for further details.

Table IX. RCF Input Configurations

Channel	RCF Input Source when Bit 9 is 1
0	1
1	0
2	1
3	1

Bit 8 is used as an extra address to allow a second block of 128 words of CMEM to be addressed by the channel addresses at 0x00–0x7F. If this bit is 0, the first 128 words are written and if this bit is 1, a second 128 words is written. This bit is only used to program the Coefficient Memory. It is not used in any way by the processing and filters longer than 128 taps can be performed.

Bit 7 is used to help control the output formatting of the AD6624's RCF data. This bit is only used when the 8 + 4 or 12 + 4 floating-point modes are chosen. These modes are enabled by Bits 5 and 4 of this register below. When this bit is 0, the I and Q output

exponents are determined separately based on their individual magnitudes. When this bit is 1, the I and Q data is a complex floating-point number where I and Q use a single exponent that is determined based on the maximum magnitude of I or Q.

Bit 6 is used to force the Output Scale Factor in Bits 3–0 of this register to be used to scale the data even when one of the Floating Point Output modes is used. If the number is too large to represent with the Output Scale chosen, the mantissas of the I and Q data clip and do not overflow.

Bits 5 and 4 choose the output formatting option used by the RCF data. The options are defined in Table X and are discussed further in the Output Format section of the data sheet.

Table X. Output Formats

Bit Values	Output Option
1x	12-Bit Mantissa and 4-Bit Exponent (12 + 4)
01	8-Bit Mantissa and 4-Bit Exponent (8 + 4)
00	Fixed-Point Mode

Bits 3–0 of this register represent the Output Scale Factor of the RCF. They are used to scale the data when the output format is in fixed-point mode or when the Force Exponent bit is high.

0xA5: BIST Register for I

This register serves two purposes. The first is to allow the complete functionality of the I data path in the channel to be tested in the system. The BIST section of the data sheet should be consulted for further details. The second function is to provide access to the I output data through the microport. To accomplish this, the Map RCF data to BIST bit in the Serial Port Control register, 0xA9, should be set high. Sixteen-bits of I data can then be read through the microport in either the 8 + 4, 12 + 4, 12-bit linear or 16-bit linear output modes. This data may come from either the formatted RCF output or the CIC5 output.

0xA6: BIST Register for Q

This register serves two purposes. The first is to allow the complete functionality of Q data path in the channel to be tested in the system. The BIST section of the data sheet should be consulted for further details. The second function is to provide access to the Q output data through the microport. To accomplish this, the Map RCF data to BIST bit in the Serial Port Control register, 0xA9, should be set high. Sixteen bits of Q data can then be read through the microport in either the 8 + 4, 12 + 4, 12-bit linear or 16-bit linear output modes. This data may come from either the formatted RCF output or the CIC5 output.

0xA7: BIST Control Register

This register controls the number of outputs of the RCF or CIC filter that are observed when a BIST test is performed. The BIST signature registers at addresses 0xA5 and 0xA6 will observe this number of outputs and then terminate. The loading of these registers also starts the BIST engine running. Details of how to utilize the BIST circuitry are defined in the BIST section of the data sheet.

0xA8: RAM BIST Control Register

This register is used to test the memories of the AD6624A should they ever be suspected of a failure. Bit 0 of this register is written with a one when the channel is in SLEEP and the user waits for 1600 CLKs and then polls the bits. If Bit 1 is high, the CMEM failed the test and if Bit 2 is high, the data memory used by the RCF failed the test.

0xA9: Serial Port Control Register

This register controls the serial port of the AD6624A and, along with the RCF control register, it helps to determine the output format.

Bit 9 of this register allows the RCF or CIC5 data to be mapped to the BIST registers at addresses 0xA5 and 0xA6. When this bit is 0, the BIST register is in signature mode and ready for a self-test to be run. When this bit is 1, the output data from the RCF after formatting or the CIC5 data is mapped to these registers and can be read through the microport. In addition, when this bit is high, the DR pin for the channel delivers a 1 CLK cycle wide pulse that can be used to synchronize the host processor with the AD6624A. This signal is a 1 SCLK cycle wide pulse when this bit is 0.

Bits 8 and 7 control the output format of the SDFS pulse. When these bits are 00, there is a single SCLK cycle wide pulse for the I and Q data. When these bits are 01, the SDFS signal is high for all of the bits shifted during the serial frame. When these bits are 10 or 11, there are two SDFS pulses that are each 1 SCLK cycle wide. One pulse precedes the I word of data and the second precedes the Q word of data. When a serial port is configured as a serial slave, it should be in the first mode with these bits set to 00.

Bits 6 and 5 determine the serial word length used by the serial port. If these bits are 00, the serial ports use 12-bit words and shift 12 bits of I followed by 12 bits of Q with each shifted MSB first. If these bits are 01, the serial ports use 16-bit words and shift 16 bits of I followed by 16 bits of Q with each shifted MSB first. If these bits are 1x, the serial ports use 24-bit words and shift 24 bits of I followed by 24 bits of Q with each shifted MSB first. When the fixed point output option is chosen from the RCF control register, these bits also set the rounding correctly in the output formatter of the RCF.

Bit 4 of this register controls whether the Serial Port is a master or slave. This register powers up low so that the serial port is a slave in order to avoid contention problems on the output drivers. The serial port for channel 0 does not use this bit. The master/slave status of Serial Port 0 is set by the SBM0 pin.

Bits 3–0 control the rate of the SCLK signal when the channel is master. This four-bit bus can set the SCLK as a division of the master CLK from 1 to 16 with approximately a 50% duty cycle. The SCLK can be generated and run up to a maximum of 80 MHz. The serial division bits from this register are not used for serial port 0. The external SDIV [3:0] pins are used to determine this for Serial Port 0.

MICROPORT CONTROL

The AD6624A has an 8-bit microprocessor port and four serial input ports. The use of each of these ports is described separately below. The interaction of the ports is then described. The microport interface is a multimode interface that is designed to give flexibility when dealing with the host processor. There are two modes of bus operation: Intel nonmultiplexed mode (INM), and Motorola nonmultiplexed mode (MNM). The mode is selected based on host processor and which mode is best suited to that processor. The microport has an 8-bit data bus ($D[7:0]$), 3-bit address bus ($A[2:0]$), three control pins lines (\overline{CS} , \overline{DS} or \overline{RD} , \overline{RW} or \overline{WR}), and one status pin (\overline{DTACK} or \overline{RDY}). The functionality of the control signals and status line changes slightly, depending upon the mode that is chosen. Refer to the timing diagrams and the following descriptions for details on the operation of both modes.

External Memory Map

The External Memory Map is used to gain access to the Channel Address Space described previously. The 8-bit data and address registers referenced by the external interface registers can be seen in the Table XI. (These registers are collectively referred to as the External Interface Registers since they control all accesses to the Channel Address space as well as global chip functions.) The use of each of these individual registers is described below in detail. It should be noted that the Serial Control interface to Channel 0 has the same memory map as the microport interface and can carry out *exactly* the same functions, although at a slower rate.

Table XI. External Memory Map

A[2:0]	Name	Comment
111	Access Control Register (ACR)	7: Auto Increment 6: Broadcast 5–2: Instruction[3:0] 1–0: A[9:8]
110	Channel Address Register (CAR)	7–0: A[7:0]
101	SOFT_SYNC Control Register (Write Only)	7: PN_EN 6: Test_MUX_Select 5: Hop 4: Start 3: SYNC 3 2: SYNC 2 1: SYNC 1 0: SYNC 0
100	PIN_SYNC Control Register (Write Only)	7: Toggle IEN for BIST 6: First SYNC Only 5: Hop_En 4: Start_En 3: SYNC_EN 3 2: SYNC_EN 2 1: SYNC_EN 1 0: SYNC_EN 0
011	SLEEP (Write Only)	7–6: Reserved 5: Access Input Port Control Registers 4: Serial Read 0 3: SLEEP 2: SLEEP 2 1: SLEEP 1 0: SLEEP 0
010	Data Register 2 (DR2)	7–4: Reserved 3–0: D [19:16]
001	Data Register 1 (DR1)	15–8: D [15:8]
000	Data Register 0 (DR0)	7–0: D [7:0]External

AD6624A

Access Control Register (ACR)

The Access Control Register serves to define the channel or channels that receive an access from the microport or Serial Port 0.

Bit 7 of this register is the autoincrement bit. If this bit is a 1, the CAR register described below will increment its value after every access to the channel. This allows blocks of address space such as Coefficient Memory to be initialized more efficiently.

Bit 6 of the register is the broadcast bit and determines how Bits 5–2 are interpreted. If broadcast is 0, Bits 5–2, which are referred to as instruction bits (Instruction [3:0]), are compared with the CHIP_ID [3:0] pins. The instruction that matches the CHIP_ID [3:0] pins will determine the access. This allows up to 16 chips to be connected to the same port and memory mapped without external logic. This also allows the same serial port of a host processor to configure up to 16 chips. If the broadcast bit is high, the Instruction [3:0] word allows multiple AD6624A channels and/or chips to be configured simultaneously, independent of the CHIP_ID[3:0] pins. Ten possible instructions are defined in Table XII. This is useful for smart antenna systems where multiple channels listening to a single antenna or carrier can be simultaneously configured. The x(s) in the table represent “don’t cares” in the digital decoding.

Table XII. Microport Instructions

Instruction	Comment
0000	All chips and all channels will get the access.
0001	Channel 0, 1, 2 of all chips will get the access.
0010	Channel 1, 2, 3 of all chips will get the access.
0100	All chips will get the access.*
1000	All chips with Chip_ID[3:0] = xxx0 will get the access.*
1001	All chips with Chip_ID[3:0] = xxx1 will get the access.*
1100	All chips with Chip_ID[3:0] = xx00 will get the access.*
1101	All chips with Chip_ID[3:0] = xx01 will get the access.*
1110	All chips with Chip_ID[3:0] = xx10 will get the access.*
1111	All chips with Chip_ID[3:0] = xx11 will get the access.*

*A[9:8] bits control which channel is decoded for the access.

External Memory Map

When broadcast is enabled (Bit 6 set high), readback is not valid because of the potential for internal bus contention. Therefore, if readback is subsequently desired, the broadcast bit should be set low.

Bits 1–0 of this register are address bits that decode which of the four channels are being accessed. If the Instruction bits decode an access to multiple channels, these bits are ignored. If the Instruction decodes an access to a subset of chips, the A[9:8] bits will otherwise determine the channel being accessed.

Channel Address Register (CAR)

This register represents the 8-bit internal address of each channel. If the autoincrement bit of the ACR is 1, this value will be incremented after every access to the DR0 register, which will in turn access the location pointed to by this address. The Channel Address register cannot be read back while the broadcast bit is set high.

SOFT_SYNC Control Register

External Address [5] is the SOFT_SYNC control register and is write only.

Bits 0–3 of this register are the SOFT_SYNC control bits. These pins may be written to by the controller to initiate the synchronization of a selected channel. Although there are four inputs, these do not necessarily go to the channel of the same number. This is fully configurable at the channel level as to which bit to look at. All four channels may be configured to synchronize from a single position, or they may be paired or all independent.

Bit 4 determines if the synchronization is to apply to a chip start. If this bit is set, a chip start will be initiated.

Bit 5 determines if the synchronization is to apply to a chip hop. If this bit is set, the NCO frequency will be updated when the SOFT_SYNC occurs.

Bit 6 configures how the internal data bus is configured. If this bit is set low, the internal ADC data buses are configured normally. If this bit is set, the internal test signals are selected. The internal test signals are configured in Bit 7 of this register.

Bit 7 if set clear, a negative full-scale signal is generated and made available to the internal data bus. If this bit is high, internal pseudo-random sequence generator is enabled and this data is available to the internal data bus. The combined functions of Bits 6 and 7 facilitate verification of a given filter design. Also, in conjunction with the MISR registers, allow for detailed in-system chip testing. In conjunction with the JTAG test board, very high levels of chip verification can be done during system test, in both the factory and field.

PIN_SYNC Control Register

External Address [4] is the PIN_SYNC control register and is write only.

Bits 0–3 of this register are the SYNC_EN control bits. These pins may be written to by the controller to allow pin synchronization of a selected channel. Although there are four inputs, these do not necessarily go to the channel of the same number. This is fully configurable at the channel level as to which bit to look at. All four channels may be configured to synchronize from a single position, or they may be paired or all independent.

Bit 4 determines if the synchronization is to apply to a chip start. If this bit is set, a chip start will be initiated when the PIN_SYNC occurs.

Bit 5 determines if the synchronization is to apply to a chip hop. If this bit is set, the NCO Frequency will be updated when the when the PIN_SYNC occurs.

Bit 6 is used to ignore repetitive synchronization signals. In some applications, this signal may occur periodically. If this bit is clear, each PIN_SYNC will restart/hop the channel. If this bit is set, only the first occurrence will cause the chip to take action.

Bit 7 is used with Bits 6 and 7 of external address 5. When this bit is cleared, the data supplied to the internal data bus simulates a normal ADC. When this bit is set, the data supplied is in the form of a time-multiplexed ADC such as the AD6600 (this allows the equivalent of testing in the 4-channel input mode). Internally, when set, this bit forces the IEN pin to toggle as if it were driven by the A/B signal of the AD6600.

SLEEP Control Register

External Address [3] is the sleep register.

Table XIII. Memory Map for Input Port Control Registers

Ch Address	Register	Bit Width	Comments
00	Lower Threshold A	10	9–0: Lower Threshold for Input A
01	Upper Threshold A	10	9–0: Upper Threshold for Input A
02	Dwell Time A	20	19–0: Minimum Time below Lower Threshold A
03	Gain Range A Control Register	5	4: Output Polarity LIA-A and LIA-B 3: Interleaved Channels 2–0: Linearization Hold-Off Register
04	Lower Threshold B	10	9–0: Lower Threshold for Input B
05	Upper Threshold B	10	9–0: Upper Threshold for Input B
06	Dwell Time B	20	19–0: Minimum Time below Lower Threshold B
07	Gain Range B Control Register	5	4: Output Polarity LIB-A and LIB-B 3: Interleaved Channels 2–0: Linearization Hold-Off Register

Bits 3–0 control the state of each of the channels. Each bit corresponds to one of the possible RSP channels within the device. If this bit is cleared, the channel operates normally. However, when this bit is set, the indicated channel enters a low power sleep mode.

Bit 4 causes the normal RSP data on serial channel 0 to be replaced with read access data. This allows reading the internal registers over the serial bus. It should be noted that in the mode, any RSP data will be superseded by internal access data.

Bit 5 allows access to the Input Control Port Registers at channel addresses 00-07. When this bit is set low, the normal memory map is accessed. However, when this bit is set, it allows access to the Input Port Control Registers. Access to these registers allows the lower and upper thresholds to be set along with dwell time and other features. When this bit is set, the value in external address 6 (CAR) points to the memory map for the Input Port Control Registers instead of the normal memory map. See Input Port Control Registers below.

Bits 6–7 are reserved and should be set low.

Data Address Registers

External Address [2–0] form the data registers DR2, DR1, and DR0 respectively. All internal data words have widths that are less than or equal to 20 bits. Accesses to External Address [0] DR0 trigger an internal access to the AD6624A based on the address indicated in the ACR and CAR. Thus during writes to the internal registers, External Address [0] DR0 must be written last. At this point, data is transferred to the internal memory indicated in A[9:0]. Reads are performed in the opposite direction. Once the address is set, External Address [0] DR0 must be the first data register read to initiate an internal access. DR2 is only four bits wide. Data written to the upper four bits of this register will be ignored. Likewise, reading from this register will produce only four LSBs.

Write Sequencing

Writing to an internal location is achieved by first writing the upper two bits of the address to Bits 1 through 0 of the ACR. Bits 7:2 may be set to select the channel as indicated above. The CAR is then written with the lower eight bits of the internal address (it does not matter if the CAR is written before the ACR as long as both are written before the internal access). Data Register 2, (DR2) and Data Register 1 (DR1) must be

written first because the write to Data Register DR0 triggers the internal access. Data Register DR0 must always be the last register written to initiate the internal write.

Read Sequencing

Reading from the microport is accomplished in the same manner. The internal address is set up the same way as the write. A read from Data Register DR0 activates the internal read, thus register DR0 must always be read first to initiate an internal read followed by DR1 and DR2. This provides the eight LSBs of the internal read through the microport (D[7:0]). Additional data registers can be read to read the balance of the internal memory.

Read/Write Chaining

The microport of the AD6624A allows for multiple accesses while \overline{CS} is held low (\overline{CS} can be tied permanently low if the microport is not shared with additional devices). The user can access multiple locations by pulsing the \overline{WR} or \overline{RD} line and changing the contents of the external 3-bit address bus. External access to the external registers of Table II is accomplished in one of two modes using the \overline{CS} , \overline{RD} , \overline{WR} , and MODE inputs. The access modes are Intel Nonmultiplexed Mode and Motorola Nonmultiplexed Mode. These modes are controlled by the MODE input (MODE = 0 for INM, MODE = 1 for MNM). \overline{CS} , \overline{RD} , and \overline{WR} control the access type for each mode.

Intel Nonmultiplexed Mode (INM)

MODE must be tied low to operate the AD6624A microprocessor in INM mode. The access type is controlled by the user with the \overline{CS} , \overline{RD} (\overline{DS}), and \overline{WR} (RW) inputs. The RDY (\overline{DTACK}) signal is produced by the microport to communicate to the user that an access has been completed. RDY (\overline{DTACK}) goes low at the start of the access and is released when the internal cycle is complete. See the timing diagrams for both the read and write modes in the specifications.

Motorola Nonmultiplexed Mode (MNM)

MODE must be tied high to operate the AD6624A microprocessor in MNM mode. The access type is controlled by the user with the \overline{CS} , \overline{DS} (\overline{RD}), and RW (\overline{WR}) inputs. The \overline{DTACK} (RDY) signal is produced by the microport to communicate to the user that an access has been completed. \overline{DTACK} (RDY) goes low when an internal access is complete and then will return high after \overline{DS} (\overline{RD}) is deasserted. See the timing diagrams for both the read and write modes in the specifications.

AD6624A

Input Port Control Registers

The Input Port control register enables various input-related features used primarily for input detection and level control. Depending on the mode of operation, up to four different signal paths can be monitored with these registers. These features are accessed by setting Bit 5 of external address 3 (Sleep Register) and then using the CAR (external address 6) to address the eight available locations.

Response to these settings is directed to the LIA-A, LIA-B, LIB-A and LIB-B pins.

Address 00 is the lower threshold for Input Channel A. This word is 10 bits wide and maps to the 10 most significant bits of the mantissa. If the upper 10 bits are less than or equal to this value, the lower threshold has been met. In normal chip operation, this starts the dwell time counter. If the input signal increases above this value, the counter is reloaded and awaits the input to drop back to this level.

Address 01 is the upper threshold for Input Channel A. This word is 10 bits wide and maps to the 10 most significant bits of the mantissa. If the upper 10 bits are greater than or equal to this value, the upper threshold has been met. In normal chip operation, this will cause the appropriate LI pin (LIA-A or LIA-B) to become active.

Address 02 is the dwell time for input Channel A. This sets the time that the input signal must be at or below the lower threshold before the LI pin is deactivated. For the input level detector to work, the dwell time must be set to at least one. If set to zero, the LI functions are disabled.

Address 02 has a 20-bit register. When the lower threshold is met following an excursion into the upper threshold, the dwell time counter is loaded and begins to count high-speed clock cycles as long as the input is at or below the lower threshold. If the signal increases above the lower threshold, the counter is reloaded and waits for the signal to fall below the lower threshold again.

Address 03 configures Input Channel A.

Bit 4 determines the polarity of LIA-A and LIA-B. If this bit is cleared, the LI signal is high when the upper threshold has been exceeded. However, if this bit is set, the LI pin is low when active. This allows maximum flexibility when using this function.

Bit 3 determines if the input consists of a single channel or TDM channels such as when using the AD6600. If this bit is cleared, a single ADC is assumed. In this mode, LIA-A functions as the active output indicator. LIA-B provides the complement of LIA-A. However, if this bit is set, the input is determined to be dual channel and determined by the state of the IENA pin. If

the IENA pin is low, the input detection is directed to LIA-A. If the IENA pin is high, the input is directed to LIA-B. In either case, Bit 4 determines the actual polarity of these signals.

Bits 2–0 determine the internal latency of the gain detect function. When the LIA-A, B pins are made active, they are typically used to change an attenuator or gain stage. Since this is prior to the ADC, there is a latency associated with the ADC and with the settling of the gain change. This register allows the internal delay of the LIA-A, B signal to be programmed.

Addresses 4–7 duplicate address 00–03 for Input Port B (INB[13:0]).

SERIAL PORT CONTROL

The AD6624A will have four serial ports serving as primary data output interfaces. In addition to output data, these ports will provide control paths to the internal functions of the AD6624A. Serial Port 0 (SDIN0) can access all of the internal registers for all of the channels while Ports 1, 2, and 3 (SDIN1–3) are limited to their local registers only. In this manner, a single DSP could be used to control the AD6624A over the Serial Port 0 interface. The option is present to use a DSP per channel if needed. In addition to the global access of Serial Port 0, it has preemptive access over the other serial ports and the micropport.

The Serial Output and Input functions use mainly separate hardware and can largely be considered separate ports that use a common Serial Clock (SCLK). The Serial Input Port is self-framing as described below and allows more efficient use of the Serial Input Bandwidth for Programming. Hence, the state of the SDFS signal has no direct impact on the Serial Input Port. Since the Serial Input Port is self-framing, it is not necessary to wait for an SDFS to perform a serial write. The beginning of a Serial Input Frame is signaled by a FRAME bit that appears on the SDI pin. This is the MSB of the Serial Input Frame. After the FRAME bit has been sampled high on the falling edge of SCLK a State Counter will start and enable an 11-bit Serial Shifter four serial clock cycles later. These four SCLK cycles represent the “don’t care” bits of the Serial Frame that are ignored. After all of the bits are shifted, the Serial Input Port will pass along the 8-bit data and 3-bit address to the arbitration block.

The Serial Word Structure for the SDI input is illustrated in the table below. Only 15 bits are listed so that the second bit in a standard 16-bit serial word is considered the FRAME bit. This is done for compatibility with the AD6620 Serial Input Port. The shifting order begins with FRAME and shifts the address MSB first and then the data MSB first.

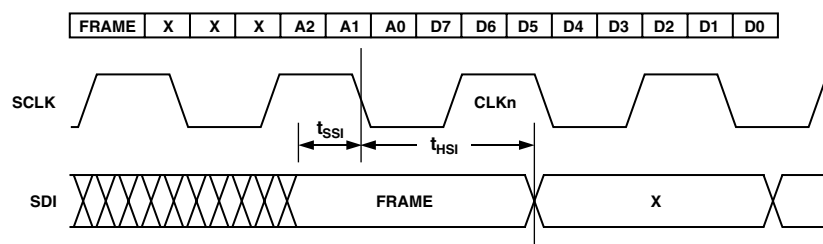

Figure 45. Serial Port Control Timing

JTAG BOUNDARY SCAN

The AD6624A supports a subset of IEEE Standard 1149.1 specifications. For additional details of the standard, please see “IEEE Standard Test Access Port and Boundary-Scan Architecture,” IEEE-1149 publication from IEEE.

The AD6624A has five pins associated with the JTAG interface. These pins are used to access the on-chip Test Access Port and are listed in the table below. All input JTAG pins are pull-up, except for TCLK which has a pull-down.

Table XIV. Boundary Scan Test Pins

Name	Pin Number	Description
TRST	67	Test Access Port Reset
TCLK	68	Test Clock
TMS	69	Test Access Port Mode Select
TDI	72	Test Data Input
TDO	70	Test Data Output

The AD6624A supports the op codes as shown below. These instructions set the mode of the JTAG interface. Address 02 is the dwell time for input channel A. This sets the

Table XV. Boundary Scan Op Codes

Instruction	Op Code
IDCODE	001
BYPASS	111
SAMPLE/PRELOAD	010
EXTEST	000
HIGHZ	011
CLAMP	100

The Vendor Identification Code can be accessed through the IDCODE instruction and has the following format.

Table XVI. Vendor ID Code

MSB Version	Part Number	Manufacturing ID #	LSB Mandatory
0000	0010 0111 1000 1100	000 1110 0101	1

A BSDL file for this device is available; please contact Analog Devices, Inc. for more information.

EXTEST (3'b000) Places the IC into an external boundary-test mode and selects the boundary-scan register to be connected between TDI and TDO. During this, the boundary-scan register is accessed to drive test data off-chip via boundary outputs and receive test data off-chip from boundary inputs.

IDCODE (3'b001) Allows the IC to remain in its functional mode and selects device ID register to be connected between TDI and TDO. Accessing the ID register does not interfere with the operation of the IC.

SAMPLE/PRELOAD (3'b010) Allows the IC to remain in normal functional mode and selects the boundary-scan register to be connected between TDI and TDO. The boundary-scan register can be accessed by a scan operation to take a sample of the functional data entering and leaving the IC. Also, test data can be preloaded into the boundary scan register before an EXTEST instruction.

HIGHZ (3'b011) Sets all outputs to high impedance state. Selects the 1-bit bypass register to be connected between TDI and TDO.

CLAMP (3'b100) Sets the outputs of the IC to logic levels determined by the boundary-scan register and selects the 1-bit bypass register to be connected between TDI and TDO. Before this instruction, boundary-scan data can be preloaded with the SAMPLE/PRELOAD instruction.

BYPASS (3'b111) Allows the IC to remain in normal functional mode and selects 1-bit bypass register between TDI and TDO. During this instruction, serial data is transferred from TDI to TDO without affecting operation of the IC.

INTERNAL WRITE ACCESS

Up to 20 bits of data (as needed) can be written by the process described below. Any high order bytes that are needed are written to the corresponding data registers defined in the external 3-bit address space. The least significant byte is then written to DR0 at address (000). When a write to DR0 is detected, the internal microprocessor port state machine then moves the data in DR2-DR0 to the internal address pointed to by the address in the LAR and AMR.

Write Pseudocode

```
void write_micro(ext_address, int data);
```

```
main();
```

```
{
```

```
/* This code shows the programming of the NCO phase offset register using the write_micro function as defined above. The variable address is the External Address A[2:0] and data is the value to be placed in the external interface register.
```

```
Internal Address = 0x087
```

```
*/
```

```
// holding registers for NCO phase byte wide access data  
int d1, d0;
```

```
// NCO frequency word (16-bits wide)  
NCO_PHASE = 0xCBEF;
```

```
// write ACR  
write_micro(7, 0x03);
```

```
// write CAR  
write_micro(6, 0x03);
```

```
// write DR1 with D[15:8]  
d1 = (NCO_PHASE & 0xFF00) >> 8;  
write_micro(1, d1);
```

```
// write DR0 with D[7:0]  
// On this write all data is transferred to the internal address  
d0 = NCO_FREQ & 0xFF;  
write_micro(0, d0);
```

```
} // end of main
```

AD6624A

INTERNAL READ ACCESS

A read is performed by first writing the CAR and AMR as with a write. The data registers (DR2–DR0) are then read in the reverse order that they were written. First, the least significant byte of the data (D[7:0]) is read from DR0. On this transaction, the high bytes of the data are moved from the internal address pointed to by the CAR and AMR into the remaining data registers (DR2–DR1). This data can then be read from the data registers using the appropriate 3-bit addresses. The number of data registers used depends solely on the amount of data to be read or written. Any unused bit in a data register should be masked out for a read.

Read Pseudocode

```
int read_micro(ext_address);
main();
{
/* This code shows the reading of the first RCF coefficient using
the read_micro function as defined above. The variable address
is the External Address A[2..0].
Internal Address = 0x000
*/
```

```
// holding registers for the coefficient
int d2, d1, d0;
// coefficient (20-bits wide)
long coefficient;
// write AMR
write_micro(7, 0x00);
// write LAR
write_micro(6, 0x00);
/* read D[7:0] from DR0, All data is moved from the Internal
Registers to the interface registers on this access */
d0 = read_micro(0) & 0xFF;
// read D[15:8] from DR1
d1 = read_micro(1) & 0xFF;
// read D[23:16] from DR2
d2 = read_micro(2) & 0x0F;
coefficient = d0 + (d1 << 8) + (d2 << 16);
} // end of main
```

OUTLINE DIMENSIONS

Dimensions shown in inches and (mm).

**196-Lead PBGA
(BC-196)**

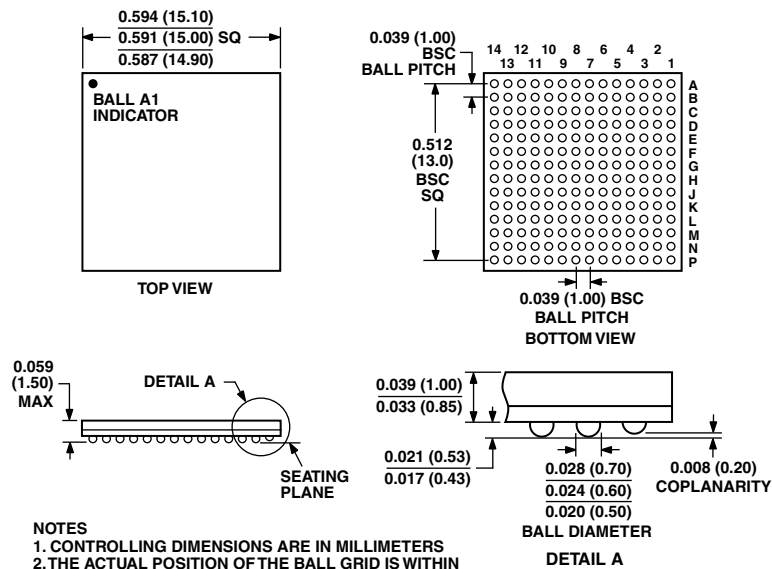

NOTES

1. CONTROLLING DIMENSIONS ARE IN MILLIMETERS
2. THE ACTUAL POSITION OF THE BALL GRID IS WITHIN 0.008 (0.20) OF ITS IDEAL POSITION RELATIVE TO THE PACKAGE EDGES.
3. THE ACTUAL POSITION OF EACH BALL IS WITHIN 0.004 (0.10) OF ITS IDEAL POSITION TO THE BALL GRID.
4. CENTER FIGURES ARE NOMINAL DIMENSIONS.

Looking for pricing, stock, or lifecycle information?

Click below to explore more details on WIN SOURCE:

- ⊖ [View AD6624AS on WIN SOURCE](#)
- ⊖ [Analog Devices Inc. Information](#)

Optimize Your Supply Chain with WIN SOURCE Solutions

- ✓ Global Sourcing Solution
- ✓ Obsolete Management
- ✓ Cost Control Management
- ✓ Shortage Management
- ✓ Alternative Solution
- ✓ Excess Inventory Management