



# THE DATASHEET OF PLC-60-48





- Features :
- Universal AC input / Full range
  - High efficiency up to 89%
  - Adjustable output voltage and current level
  - Protections: Short circuit / Over current / Over voltage / Over temperature
  - Cooling by free air convection
  - Built-in constant current limiting circuit
  - Fully isolated plastic case with terminal block style of I/O
  - Built-in active PFC function, comply with BS EN/EN61000-3-2 class C ( $\geq 75\%$  load)
  - Class 2 power unit
  - Pass LPS
  - 100% full load burn-in test
  - High reliability
  - Suitable for LED lighting and moving sign applications (Note.2)
  - Compliance to worldwide safety regulations for lighting
  - 2 years warranty



■ GTIN CODE

MW Search: <https://www.meanwell.com/serviceGTIN.aspx>



SPECIFICATION

MODEL		PLC-60-12	PLC-60-15	PLC-60-20	PLC-60-24	PLC-60-27	PLC-60-36	PLC-60-48	
OUTPUT	DC VOLTAGE	12V	15V	20V	24V	27V	36V	48V	
	CONSTANT CURRENT REGION Note.6	8.4 ~ 12V	10.5 ~ 15V	14 ~ 20V	16.8 ~ 24V	18.9 ~ 27V	25.2 ~ 36V	33.6 ~ 48V	
	RATED CURRENT	5A	4A	3A	2.5A	2.3A	1.7A	1.3A	
	CURRENT RANGE	0 ~ 5A	0 ~ 4A	0 ~ 3A	0 ~ 2.5A	0 ~ 2.3A	0 ~ 1.7A	0 ~ 1.3A	
	RATED POWER	60W	60W	60W	60W	62.1W	61.2W	62.4W	
	RIPPLE & NOISE (max.) Note.2	2Vp-p	2.4Vp-p	1.8Vp-p	2.4Vp-p	2.7Vp-p	3.6Vp-p	4.6Vp-p	
	VOLTAGE ADJ. RANGE Note.5	11.5 ~ 13V	14.5 ~ 16.2V	19.5 ~ 22V	24 ~ 26V	25 ~ 30V	32.5 ~ 39V	43.6 ~ 51.8V	
	CURRENT ADJ. RANGE Note.5	3.75 ~ 5.15A	3 ~ 4.12A	2.25 ~ 3.09A	1.875 ~ 2.575A	1.725 ~ 2.369A	1.275 ~ 1.751A	0.975 ~ 1.339A	
	VOLTAGE TOLERANCE Note.3	$\pm 10\%$							
	LINE REGULATION	$\pm 3.0\%$							
LOAD REGULATION	$\pm 5.0\%$								
SETUP TIME	500ms / 230VAC 3000ms / 115VAC at full load								
INPUT	VOLTAGE RANGE Note.4	90 ~ 264VAC		127 ~ 370VDC					
	FREQUENCY RANGE	47 ~ 63Hz							
	POWER FACTOR (Typ.)	PF>0.92/115VAC, PF>0.9/230VAC at full load (Please refer to "Power Factor Characteristic" curve)							
	TOTAL HARMONIC DISTORTION	THD< 20% when output loading $\geq 75\%$ at 115VAC/230VAC input							
	EFFICIENCY (Typ.)	86%	86%	87.5%	87%	88%	89%	89%	
	AC CURRENT (Typ.)	0.8A/115VAC		0.4A/230VAC					
	INRUSH CURRENT (Typ.)	COLD START 35A(twidth=35 $\mu$ s measured at 50% Ipeak) at 230VAC							
	MAX. No. of PSUs on 16A CIRCUIT BREAKER	32 units (circuit breaker of type B) / 32 units (circuit breaker of type C) at 230VAC							
LEAKAGE CURRENT	<0.75mA / 240VAC								
PROTECTION	OVER CURRENT	95 ~ 110% Protection type : Constant current limiting, recovers automatically after fault condition is removed							
	SHORT CIRCUIT	Hiccup mode, recovers automatically after fault condition is removed.							
	OVER VOLTAGE	13.8 ~ 16V	17.5 ~ 21V	23 ~ 26V	28 ~ 32V	31 ~ 35V	41 ~ 46V	54 ~ 60V	
	OVER TEMPERATURE	Shut down o/p voltage, recovers automatically after temperature goes down							
ENVIRONMENT	WORKING TEMP.	-30 ~ +50 $^{\circ}$ C (Refer to "Derating Curve")							
	WORKING HUMIDITY	20 ~ 95% RH non-condensing							
	STORAGE TEMP., HUMIDITY	-40 ~ +80 $^{\circ}$ C, 10 ~ 95% RH							
	TEMP. COEFFICIENT	$\pm 0.03\%/^{\circ}$ C (0 ~ 50 $^{\circ}$ C)							
	VIBRATION	10 ~ 500Hz, 2G 12min./1cycle, period for 72min. each along X, Y, Z axes							
SAFETY & EMC	SAFETY STANDARDS	UL1310, TUV BS EN/EN61347-1, BS EN/EN61347-2-13, GB19510.14, GB19510.1, CAN/CSA C22.2 No. 223-M91(except for 48V), EAC TP TC 004 approved							
	WITHSTAND VOLTAGE	I/P-O/P:3.75KVAC		I/P-FG:2KVAC		O/P-FG:0.5KVAC			
	ISOLATION RESISTANCE	I/P-O/P:100M Ohms / 500VDC / 25 $^{\circ}$ C / 70% RH							
	EMC EMISSION	Compliance to BS EN/EN55015, GB/T 17743, GB17625.1, BS EN/EN61000-3-2 Class C ( $\geq 75\%$ load) ; BS EN/EN61000-3-3, EAC TP TC 020							
	EMC IMMUNITY	Compliance to BS EN/EN61000-4-2,3,4,5,6,8,11, BS EN/EN55024,BS EN/EN61547, light industry level ,EAC TP TC 020							
OTHERS	MTBF	3445.4K hrs min. Telcordia SR-332 (Bellcore)		515.0Khrs min.		MIL-HDBK-217F (25 $^{\circ}$ C)			
	DIMENSION	181.5*62*35mm (L*W*H)							
	PACKING	0.41Kg; 30pcs/13.3Kg/0.67CUFT							
NOTE	<ol style="list-style-type: none"> <li>1. All parameters NOT specially mentioned are measured at 230VAC input, rated load and 25<math>^{\circ}</math>C of ambient temperature.</li> <li>2. Ripple &amp; noise are measured at 20MHz of bandwidth by using a 12" twisted pair-wire terminated with a 0.1uF &amp; 47uF parallel capacitor.</li> <li>3. Tolerance : includes set up tolerance, line regulation and load regulation.</li> <li>4. Derating may be needed under low input voltage. Please check the static characteristics for more details.</li> <li>5. Output voltage can be adjusted through the SVR1 on the PCB ; limit of output constant current level can be adjusted through the SVR2 on the PCB.</li> <li>6. Please refer to "DRIVING METHODS OF LED MODULE".</li> <li>7. The power supply is considered as a component that will be operated in combination with final equipment. Since EMC performance will be affected by the complete installation, the final equipment manufacturers must re-qualify EMC Directive on the complete installation again. (as available on <a href="https://www.meanwell.com/Upload/PDF/EML_statement_en.pdf">https://www.meanwell.com/Upload/PDF/EML_statement_en.pdf</a>)</li> <li>8. Direct connecting to LEDs is suggested, but is not suitable for using additional drivers.</li> <li>9. To fulfill requirements of the latest ErP regulation for lighting fixtures, this LED power supply can only be used behind a switch without permanently connected to the mains.</li> <li>10. The ambient temperature derating of 3.5<math>^{\circ}</math>C/1000m with fanless models and of 5<math>^{\circ}</math>C/1000m with fan models for operating altitude higher than 2000m(6500ft).</li> </ol> <p>※ Product Liability Disclaimer : For detailed information, please refer to <a href="https://www.meanwell.com/serviceDisclaimer.aspx">https://www.meanwell.com/serviceDisclaimer.aspx</a></p>								

■ Mechanical Specification

Case No.991A Unit:mm

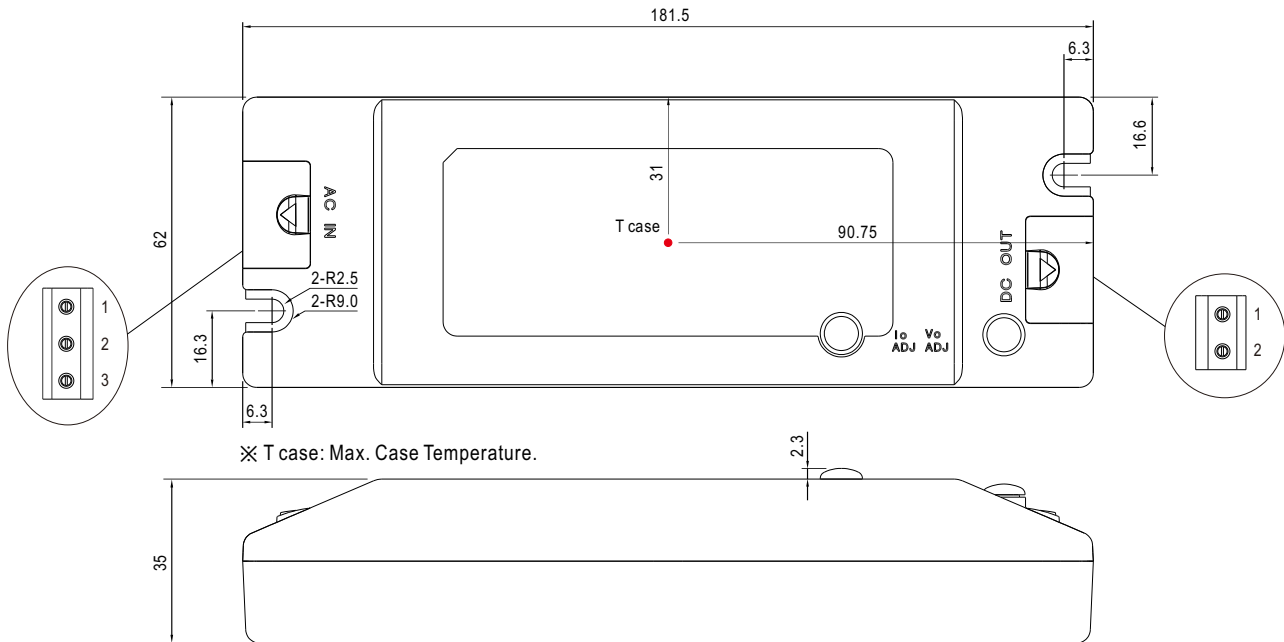

※ T case: Max. Case Temperature.

Terminal Pin No. Assignment (TB1):  
SWITCHLAB MB310-75003

Pin No.	Assignment
1	AC/L
2	AC/N
3	FG ⊕

Terminal Pin No. Assignment (TB2):  
SWITCHLAB MB310-75002

Pin No.	Assignment
1	+V
2	-V

■ Block Diagram

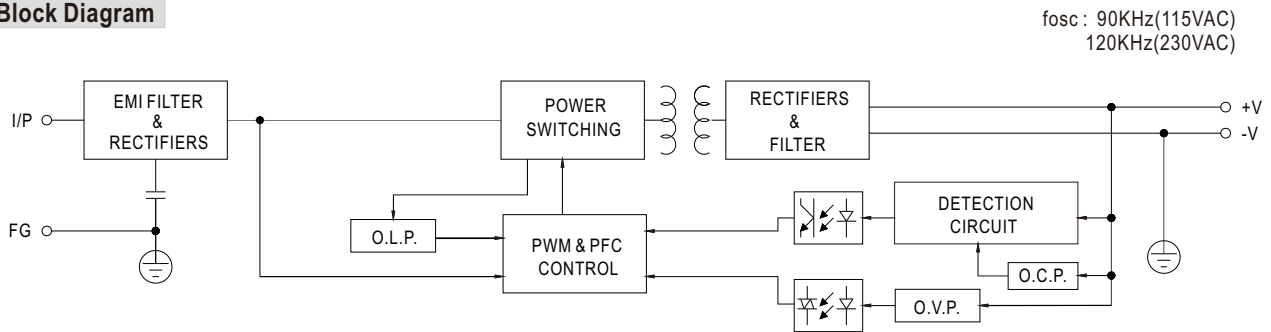

■ Derating Curve

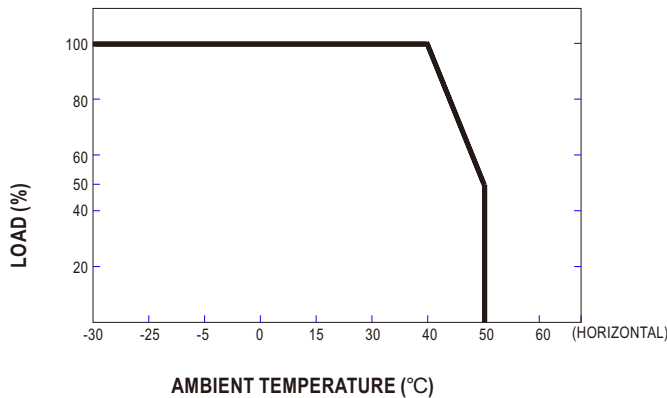

■ Static Characteristics

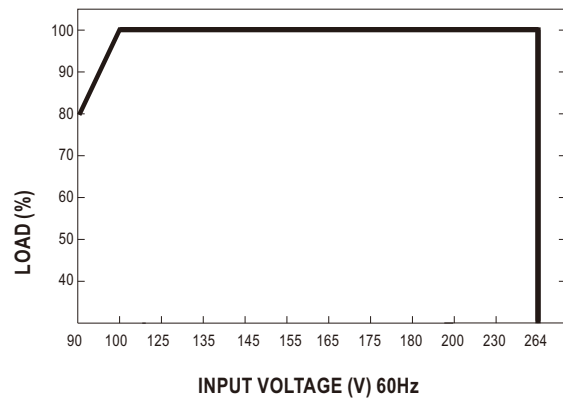

**Power Factor Characteristic**

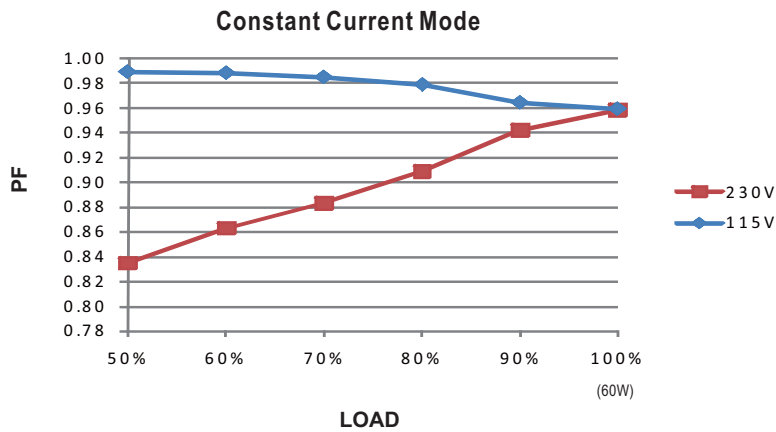

**EFFICIENCY vs LOAD (48V Model)**

PLC-60 series possess superior working efficiency that up to 89% can be reached in field applications.

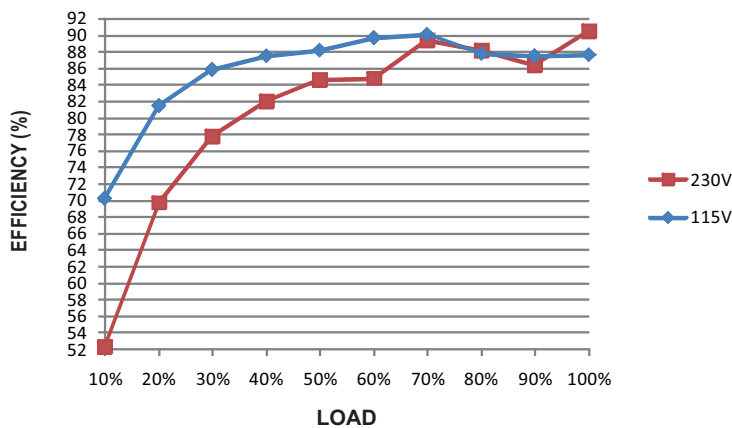

**DRIVING METHODS OF LED MODULE**

This LED power supply is suggested to work in constant current mode area (CC) to drive the LEDs.

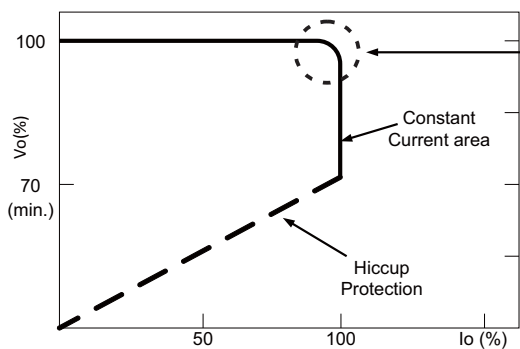

In the constant current region, the highest voltage at the output of the driver depends on the configuration of the end systems.  
Should there be any compatibility issues, please contact MEAN WELL.

## Looking for pricing, stock, or lifecycle information?

Click below to explore more details on WIN SOURCE:

- ⊖ [View PLC-60-48 on WIN SOURCE](#)
- ⊖ [Mean Well Enterprises Co., Ltd. Information](#)

## Optimize Your Supply Chain with WIN SOURCE Solutions

- ✓ Global Sourcing Solution
- ✓ Obsolete Management
- ✓ Cost Control Management
- ✓ Shortage Management
- ✓ Alternative Solution
- ✓ Excess Inventory Management