



**THE DATASHEET OF  
CY7C1620KV18-333BZXI**





**Please note that Cypress is an Infineon Technologies Company.**

The document following this cover page is marked as “Cypress” document as this is the company that originally developed the product. Please note that Infineon will continue to offer the product to new and existing customers as part of the Infineon product portfolio.

**Continuity of document content**

The fact that Infineon offers the following product as part of the Infineon product portfolio does not lead to any changes to this document. Future revisions will occur when appropriate, and any changes will be set out on the document history page.

**Continuity of ordering part numbers**

Infineon continues to support existing part numbers. Please continue to use the ordering part numbers listed in the datasheet for ordering.



# 144-Mbit DDR II SRAM Two-Word Burst Architecture

## Features

- 144-Mbit density (8M × 18, 4M × 36)
- 333 MHz clock for high bandwidth
- Two-word burst for reducing address bus frequency
- Double data rate (DDR) interfaces (data transferred at 666 MHz) at 333 MHz
- Two input clocks (K and  $\bar{K}$ ) for precise DDR timing
  - SRAM uses rising edges only
- Two input clocks for output data (C and  $\bar{C}$ ) to minimize clock skew and flight time mismatches
- Echo clocks (CQ and  $\bar{CQ}$ ) simplify data capture in high-speed systems
- Synchronous internally self-timed writes
- DDR II operates with 1.5-cycle read latency when  $\overline{DOFF}$  is asserted high
- Operates similar to DDR I device with one cycle read latency when  $\overline{DOFF}$  is asserted low
- 1.8-V core power supply with high-speed transceiver logic (HSTL) inputs and outputs
- Variable drive HSTL output buffers
- Expanded HSTL output voltage (1.4 V– $V_{DD}$ )
  - Supports both 1.5-V and 1.8-V I/O supply
- Available in 165-ball fine-pitch ball grid array (FBGA) package (15 × 17 × 1.4 mm)
- Offered in Pb-free packages
- JTAG 1149.1 compatible test access port
- Phase locked loop (PLL) for accurate data placement

## Configuration

- CY7C1618KV18 – 8M × 18
- CY7C1620KV18 – 4M × 36

## Functional Description

The CY7C1618KV18, and CY7C1620KV18 are 1.8-V synchronous pipelined SRAM equipped with DDR II architecture. The DDR II consists of an SRAM core with advanced synchronous peripheral circuitry and a 1-bit burst counter. Addresses for read and write are latched on alternate rising edges of the input (K) clock. Write data is registered on the rising edges of both K and  $\bar{K}$ . Read data is driven on the rising edges of C and  $\bar{C}$  if provided, or on the rising edge of K and  $\bar{K}$  if C/ $\bar{C}$  are not provided. On CY7C1618KV18 and CY7C1620KV18, the burst counter takes in the least significant bit of the external address and bursts two 18-bit words in the case of CY7C1618KV18 and two 36-bit words in the case of CY7C1620KV18 sequentially into or out of the device.

Asynchronous inputs include an output impedance matching input (ZQ). Synchronous data outputs (Q, sharing the same physical pins as the data inputs D) are tightly matched to the two output echo clocks CQ/ $\bar{CQ}$ , eliminating the need for separately capturing data from each individual DDR SRAM in the system design. Output data clocks (C/ $\bar{C}$ ) enable maximum system clocking and data synchronization flexibility.

All synchronous inputs pass through input registers controlled by the K or  $\bar{K}$  input clocks. All data outputs pass through output registers controlled by the C or  $\bar{C}$  (or K or  $\bar{K}$  in a single clock domain) input clocks. Writes are conducted with on-chip synchronous self-timed write circuitry.

For a complete list of related documentation, click [here](#).

## Selection Guide

Description		333 MHz	300 MHz	250 MHz	Unit
Maximum operating frequency		333	300	250	MHz
Maximum operating current	× 18	650	610	Not Offered	mA
	× 36	790	Not Offered	660	

Logic Block Diagram – CY7C1618KV18

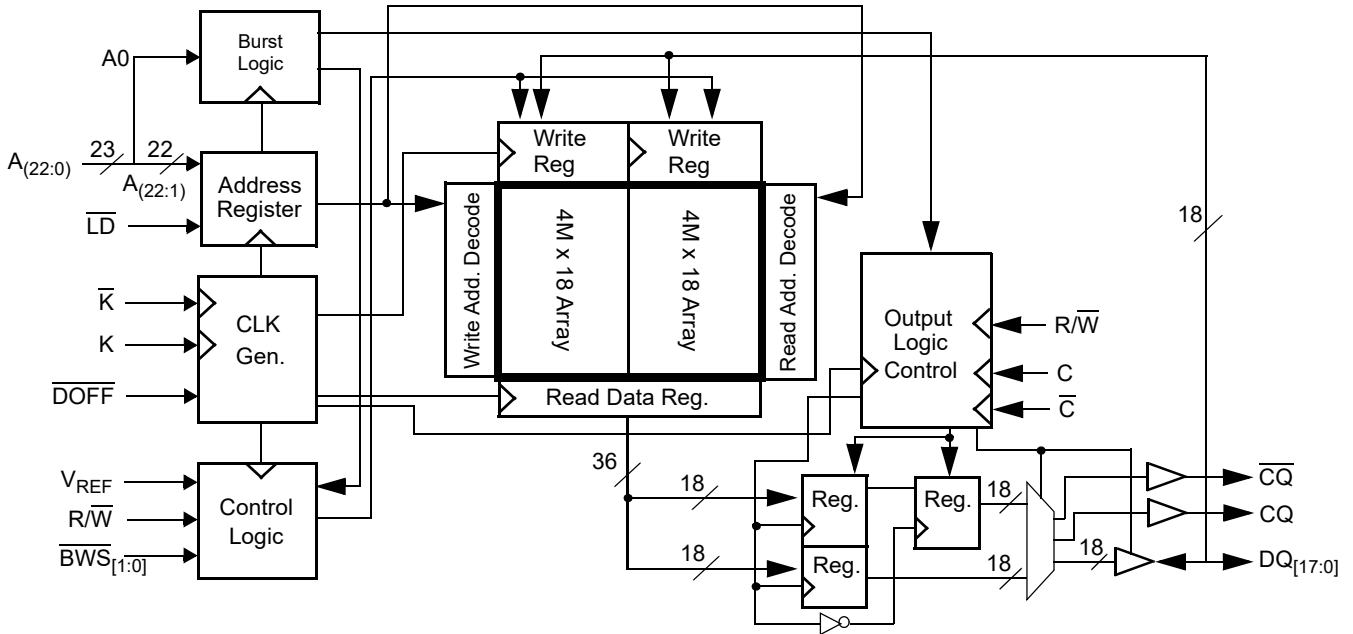

Logic Block Diagram – CY7C1620KV18

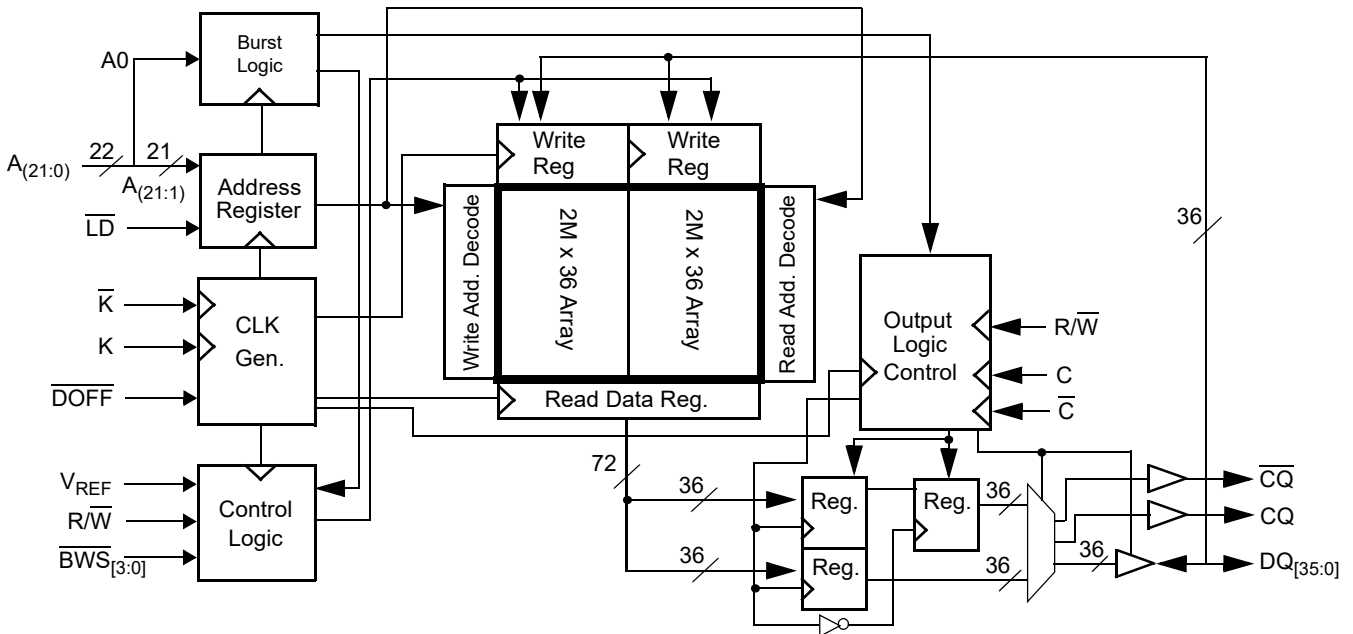

## Contents

<b>Pin Configurations</b> .....	<b>4</b>	<b>Instruction Codes</b> .....	<b>18</b>
<b>Pin Definitions</b> .....	<b>5</b>	<b>Boundary Scan Order</b> .....	<b>19</b>
<b>Functional Overview</b> .....	<b>6</b>	<b>Power Up Sequence in DDR II SRAM</b> .....	<b>20</b>
Read Operations .....	6	Power Up Sequence .....	20
Write Operations .....	6	PLL Constraints .....	20
Byte Write Operations .....	6	<b>Maximum Ratings</b> .....	<b>21</b>
Single Clock Mode .....	7	<b>Operating Range</b> .....	<b>21</b>
DDR Operation .....	7	<b>Neutron Soft Error Immunity</b> .....	<b>21</b>
Depth Expansion .....	7	<b>Electrical Characteristics</b> .....	<b>21</b>
Programmable Impedance .....	7	DC Electrical Characteristics .....	21
Echo Clocks .....	7	<b>AC Electrical Characteristics</b> .....	<b>23</b>
PLL .....	7	<b>Capacitance</b> .....	<b>23</b>
<b>Application Example</b> .....	<b>8</b>	<b>Thermal Resistance</b> .....	<b>23</b>
<b>Truth Table</b> .....	<b>9</b>	<b>AC Test Loads and Waveforms</b> .....	<b>23</b>
<b>Burst Address Table</b> .....	<b>9</b>	<b>Switching Characteristics</b> .....	<b>24</b>
<b>Write Cycle Descriptions</b> .....	<b>10</b>	<b>Switching Waveforms</b> .....	<b>26</b>
<b>Write Cycle Descriptions</b> .....	<b>11</b>	Read/Write/Deselect Sequence .....	26
<b>IEEE 1149.1 Serial Boundary Scan (JTAG)</b> .....	<b>12</b>	<b>Ordering Information</b> .....	<b>27</b>
Disabling the JTAG Feature .....	12	Ordering Code Definitions .....	27
Test Access Port .....	12	<b>Package Diagram</b> .....	<b>28</b>
Performing a TAP Reset .....	12	<b>Acronyms</b> .....	<b>29</b>
TAP Registers .....	12	<b>Document Conventions</b> .....	<b>29</b>
TAP Instruction Set .....	12	Units of Measure .....	29
<b>TAP Controller State Diagram</b> .....	<b>14</b>	<b>Document History Page</b> .....	<b>30</b>
<b>TAP Controller Block Diagram</b> .....	<b>15</b>	<b>Sales, Solutions and Legal Information</b> .....	<b>32</b>
<b>TAP Electrical Characteristics</b> .....	<b>15</b>	Worldwide Sales and Design Support .....	32
<b>TAP AC Switching Characteristics</b> .....	<b>16</b>	Products .....	32
<b>TAP Timing and Test Conditions</b> .....	<b>17</b>	PSoC® Solutions .....	32
<b>Identification Register Definitions</b> .....	<b>18</b>	Cypress Developer Community .....	32
<b>Scan Register Sizes</b> .....	<b>18</b>	Technical Support .....	32

## Pin Configurations

The pin configuration for CY7C1618KV18, and CY7C1620KV18 follow: <sup>[1]</sup>

**Figure 1. 165-ball FBGA (15 × 17 × 1.4 mm) pinout**

**CY7C1618KV18 (8M × 18)**

	1	2	3	4	5	6	7	8	9	10	11
<b>A</b>	$\overline{\text{CQ}}$	A	A	$\overline{\text{R/W}}$	$\overline{\text{BWS}}_1$	$\overline{\text{K}}$	A	$\overline{\text{LD}}$	A	A	CQ
<b>B</b>	NC	DQ9	NC	A	NC/288M	K	$\overline{\text{BWS}}_0$	A	NC	NC	DQ8
<b>C</b>	NC	NC	NC	$V_{SS}$	A	A0	A	$V_{SS}$	NC	DQ7	NC
<b>D</b>	NC	NC	DQ10	$V_{SS}$	$V_{SS}$	$V_{SS}$	$V_{SS}$	$V_{SS}$	NC	NC	NC
<b>E</b>	NC	NC	DQ11	$V_{DDQ}$	$V_{SS}$	$V_{SS}$	$V_{SS}$	$V_{DDQ}$	NC	NC	DQ6
<b>F</b>	NC	DQ12	NC	$V_{DDQ}$	$V_{DD}$	$V_{SS}$	$V_{DD}$	$V_{DDQ}$	NC	NC	DQ5
<b>G</b>	NC	NC	DQ13	$V_{DDQ}$	$V_{DD}$	$V_{SS}$	$V_{DD}$	$V_{DDQ}$	NC	NC	NC
<b>H</b>	$\overline{\text{DOFF}}$	$V_{REF}$	$V_{DDQ}$	$V_{DDQ}$	$V_{DD}$	$V_{SS}$	$V_{DD}$	$V_{DDQ}$	$V_{DDQ}$	$V_{REF}$	ZQ
<b>J</b>	NC	NC	NC	$V_{DDQ}$	$V_{DD}$	$V_{SS}$	$V_{DD}$	$V_{DDQ}$	NC	DQ4	NC
<b>K</b>	NC	NC	DQ14	$V_{DDQ}$	$V_{DD}$	$V_{SS}$	$V_{DD}$	$V_{DDQ}$	NC	NC	DQ3
<b>L</b>	NC	DQ15	NC	$V_{DDQ}$	$V_{SS}$	$V_{SS}$	$V_{SS}$	$V_{DDQ}$	NC	NC	DQ2
<b>M</b>	NC	NC	NC	$V_{SS}$	$V_{SS}$	$V_{SS}$	$V_{SS}$	$V_{SS}$	NC	DQ1	NC
<b>N</b>	NC	NC	DQ16	$V_{SS}$	A	A	A	$V_{SS}$	NC	NC	NC
<b>P</b>	NC	NC	DQ17	A	A	C	A	A	NC	NC	DQ0
<b>R</b>	TDO	TCK	A	A	A	$\overline{\text{C}}$	A	A	A	TMS	TDI

**CY7C1620KV18 (4M × 36)**

	1	2	3	4	5	6	7	8	9	10	11
<b>A</b>	$\overline{\text{CQ}}$	A	A	$\overline{\text{R/W}}$	$\overline{\text{BWS}}_2$	$\overline{\text{K}}$	$\overline{\text{BWS}}_1$	$\overline{\text{LD}}$	A	A	CQ
<b>B</b>	NC	DQ27	DQ18	A	$\overline{\text{BWS}}_3$	K	$\overline{\text{BWS}}_0$	A	NC	NC	DQ8
<b>C</b>	NC	NC	DQ28	$V_{SS}$	A	A0	A	$V_{SS}$	NC	DQ17	DQ7
<b>D</b>	NC	DQ29	DQ19	$V_{SS}$	$V_{SS}$	$V_{SS}$	$V_{SS}$	$V_{SS}$	NC	NC	DQ16
<b>E</b>	NC	NC	DQ20	$V_{DDQ}$	$V_{SS}$	$V_{SS}$	$V_{SS}$	$V_{DDQ}$	NC	DQ15	DQ6
<b>F</b>	NC	DQ30	DQ21	$V_{DDQ}$	$V_{DD}$	$V_{SS}$	$V_{DD}$	$V_{DDQ}$	NC	NC	DQ5
<b>G</b>	NC	DQ31	DQ22	$V_{DDQ}$	$V_{DD}$	$V_{SS}$	$V_{DD}$	$V_{DDQ}$	NC	NC	DQ14
<b>H</b>	$\overline{\text{DOFF}}$	$V_{REF}$	$V_{DDQ}$	$V_{DDQ}$	$V_{DD}$	$V_{SS}$	$V_{DD}$	$V_{DDQ}$	$V_{DDQ}$	$V_{REF}$	ZQ
<b>J</b>	NC	NC	DQ32	$V_{DDQ}$	$V_{DD}$	$V_{SS}$	$V_{DD}$	$V_{DDQ}$	NC	DQ13	DQ4
<b>K</b>	NC	NC	DQ23	$V_{DDQ}$	$V_{DD}$	$V_{SS}$	$V_{DD}$	$V_{DDQ}$	NC	DQ12	DQ3
<b>L</b>	NC	DQ33	DQ24	$V_{DDQ}$	$V_{SS}$	$V_{SS}$	$V_{SS}$	$V_{DDQ}$	NC	NC	DQ2
<b>M</b>	NC	NC	DQ34	$V_{SS}$	$V_{SS}$	$V_{SS}$	$V_{SS}$	$V_{SS}$	NC	DQ11	DQ1
<b>N</b>	NC	DQ35	DQ25	$V_{SS}$	A	A	A	$V_{SS}$	NC	NC	DQ10
<b>P</b>	NC	NC	DQ26	A	A	C	A	A	NC	DQ9	DQ0
<b>R</b>	TDO	TCK	A	A	A	$\overline{\text{C}}$	A	A	A	TMS	TDI

**Note**

1. NC/288M is not connected to the die and can be tied to any voltage level.

## Pin Definitions

Pin Name	I/O	Pin Description
DQ <sub>[x:0]</sub>	Input Output-Synchronous	<b>Data input output signals:</b> Inputs are sampled on the rising edge of K and $\bar{K}$ clocks during valid write operations. These pins drive out the requested data when the read operation is active. Valid data is driven out on the rising edge of both the C and $\bar{C}$ clocks during read operations or K and $\bar{K}$ when in single clock mode. When read access is deselected, Q <sub>[x:0]</sub> are automatically tristated. CY7C1618KV18 – DQ <sub>[17:0]</sub> CY7C1620KV18 – DQ <sub>[35:0]</sub>
$\bar{LD}$	Input-Synchronous	<b>Synchronous load:</b> This input is brought low when a bus cycle sequence is defined. This definition includes address and read and write direction. All transactions operate on a burst of 2 data.
$\bar{BWS}_0$ , $\bar{BWS}_1$ , $\bar{BWS}_2$ , $\bar{BWS}_3$	Input-Synchronous	<b>Byte write select (BWS) 0, 1, 2, and 3 – Active low:</b> Sampled on the rising edge of the K and $\bar{K}$ clocks during write operations. Used to select which byte is written into the device during the current portion of the write operations. Bytes not written remain unaltered. CY7C1618KV18 – $\bar{BWS}_0$ controls D <sub>[8:0]</sub> and $\bar{BWS}_1$ controls D <sub>[17:9]</sub> . CY7C1620KV18 – $\bar{BWS}_0$ controls D <sub>[8:0]</sub> , $\bar{BWS}_1$ controls D <sub>[17:9]</sub> , $\bar{BWS}_2$ controls D <sub>[26:18]</sub> and $\bar{BWS}_3$ controls D <sub>[35:27]</sub> . All the byte write selects are sampled on the same edge as the data. Deselecting a BWS ignores the corresponding byte of data and it is not written into the device.
A, A <sub>0</sub>	Input-Synchronous	<b>Address inputs:</b> These address inputs are multiplexed for both read and write operations. Internally, the device is organized as 8M × 18 (2 arrays each of 4M × 18) for CY7C1618KV18, and 4M × 36 (2 arrays each of 2M × 36) for CY7C1620KV18. CY7C1618KV18 – A <sub>0</sub> is the input to the burst counter. These are incremented in a linear fashion internally. 23 address inputs are needed to access the entire memory array. CY7C1620KV18 – A <sub>0</sub> is the input to the burst counter. These are incremented in a linear fashion internally. 22 address inputs are needed to access the entire memory array. All the address inputs are ignored when the appropriate port is deselected.
R/ $\bar{W}$	Input-Synchronous	<b>Synchronous read or write input:</b> When $\bar{LD}$ is low, this input designates the access type (read when R/ $\bar{W}$ is high, write when R/ $\bar{W}$ is low) for loaded address. R/ $\bar{W}$ must meet the setup and hold times around edge of K.
C	Input Clock	<b>Positive input clock for output data:</b> C is used in conjunction with $\bar{C}$ to clock out the read data from the device. C and $\bar{C}$ can be used together to deskew the flight times of various devices on the board back to the controller. See application example for further details.
$\bar{C}$	Input Clock	<b>Negative input clock for output data:</b> $\bar{C}$ is used in conjunction with C to clock out the read data from the device. C and $\bar{C}$ can be used together to deskew the flight times of various devices on the board back to the controller. See application example for further details.
K	Input Clock	<b>Positive input clock input:</b> The rising edge of K is used to capture synchronous inputs to the device and to drive out data through Q <sub>[x:0]</sub> when in single clock mode. All accesses are initiated on the rising edge of K.
$\bar{K}$	Input Clock	<b>Negative input clock input:</b> $\bar{K}$ is used to capture synchronous data being presented to the device and to drive out data through Q <sub>[x:0]</sub> when in single clock mode.
CQ	Output Clock	<b>CQ referenced with respect to C:</b> This is a free running clock and is synchronized to the input clock for output data (C) of the DDR II. In the single clock mode, CQ is generated with respect to K. The timing for the echo clocks is shown in the AC Timing table.
$\bar{CQ}$	Output Clock	<b><math>\bar{CQ}</math> referenced with respect to C:</b> This is a free running clock and is synchronized to the input clock for output data ( $\bar{C}$ ) of the DDR II. In the single clock mode, $\bar{CQ}$ is generated with respect to K. The timing for the echo clocks is shown in the AC Timing table.
ZQ	Input	<b>Output impedance matching input:</b> This input is used to tune the device outputs to the system data bus impedance. CQ, $\bar{CQ}$ , and Q <sub>[x:0]</sub> output impedance are set to 0.2 × RQ, where RQ is a resistor connected between ZQ and ground. Alternatively, this pin can be connected directly to V <sub>DDQ</sub> , which enables the minimum impedance mode. This pin cannot be connected directly to GND or left unconnected.

**Pin Definitions** (continued)

Pin Name	I/O	Pin Description
DOFF	Input	<b>PLL turn Off – Active low.</b> Connecting this pin to ground turns off the PLL inside the device. The timing in the PLL turned off operation differs from those listed in this data sheet. For normal operation, this pin can be connected to a pull-up through a 10 kΩ or less pull-up resistor. The device behaves in DDR I mode when the PLL is turned off. In this mode, the device can be operated at a frequency of up to 167 MHz with DDR I timing.
TDO	Output	<b>Test data-out (TDO) pin for JTAG.</b>
TCK	Input	<b>Test clock (TCK) pin for JTAG.</b>
TDI	Input	<b>Test data-in (TDI) pin for JTAG.</b>
TMS	Input	<b>Test mode select (TMS) pin for JTAG.</b>
NC	N/A	<b>Not connected to the die:</b> Can be tied to any voltage level.
NC/288M	Input	<b>Not connected to the die:</b> Can be tied to any voltage level.
V <sub>REF</sub>	Input-Reference	<b>Reference voltage input:</b> Static input used to set the reference level for HSTL inputs, outputs, and AC measurement points.
V <sub>DD</sub>	Power Supply	<b>Power supply inputs to the core of the device.</b>
V <sub>SS</sub>	Ground	<b>Ground for the device.</b>
V <sub>DDQ</sub>	Power Supply	<b>Power supply inputs for the outputs of the device.</b>

**Functional Overview**

The CY7C1618KV18, and CY7C1620KV18 are synchronous pipelined burst SRAMs equipped with a DDR interface, which operates with a read latency of one and a half cycles when DOFF pin is tied high. When DOFF pin is set low or connected to V<sub>SS</sub>, the device behaves in DDR I mode with a read latency of one clock cycle.

Accesses are initiated on the rising edge of the positive input clock (K). All synchronous input timing is referenced from the rising edge of the input clocks (K and K) and all output timing is referenced to the rising edge of the output clocks (C/C, or K/K when in single clock mode).

All synchronous data inputs (D<sub>[x:0]</sub>) pass through input registers controlled by the rising edge of the input clocks (K and K). All synchronous data outputs (Q<sub>[x:0]</sub>) pass through output registers controlled by the rising edge of the output clocks (C/C, or K/K when in single clock mode).

All synchronous control (R/W, LD, BWS<sub>[0:x]</sub>) inputs pass through input registers controlled by the rising edge of the input clock (K).

CY7C1618KV18 is described in the following sections. The same basic descriptions apply to CY7C1620KV18.

**Read Operations**

The CY7C1618KV18 is organized internally as two arrays of 2M × 18. Accesses are completed in a burst of 2 sequential 18-bit data words. Read operations are initiated by asserting R/W high and LD low at the rising edge of the positive input clock (K). The address presented to address inputs is stored in the read address register and the least significant bit of the address is presented to the burst counter. The burst counter increments the address in a linear fashion. Following the next K clock rise, the corresponding 18-bit word of data from this address location is driven onto the Q<sub>[17:0]</sub> using C as the output timing reference. On the subsequent rising edge of C, the next 18-bit data word

from the address location generated by the burst counter is driven onto the Q<sub>[17:0]</sub>. The requested data is valid 0.45 ns from the rising edge of the output clock (C or C, or K and K when in single clock mode). To maintain the internal logic, each read access must be enabled to complete. Read accesses can be initiated on every rising edge of the positive input clock (K).

When read access is deselected, the CY7C1618KV18 first completes the pending read transactions. Synchronous internal circuitry automatically tristates the output, following the next rising edge of the positive output clock (C). This enables a transition between devices without the insertion of wait states in a depth expanded memory.

**Write Operations**

Write operations are initiated by asserting R/W low and LD low at the rising edge of the positive input clock (K). The address presented to address inputs is stored in the write address register and the least significant bit of the address is presented to the burst counter. The burst counter increments the address in a linear fashion. On the following K clock rise, the data presented to D<sub>[17:0]</sub> is latched and stored into the 18-bit write data register, provided BWS<sub>[1:0]</sub> are both asserted active. On the subsequent rising edge of the Negative Input Clock (K) the information presented to D<sub>[17:0]</sub> is also stored into the write data register, provided BWS<sub>[1:0]</sub> are both asserted active. The 36 bits of data are then written into the memory array at the specified location. Write accesses can be initiated on every rising edge of the positive input clock (K). This pipelines the data flow so that 18 bits of data can be transferred into the device on every rising edge of the input clocks (K and K).

When the write access is deselected, the device ignores all inputs after the pending write operations have been completed.

**Byte Write Operations**

Byte write operations are supported by the CY7C1618KV18. A write operation is initiated as described in [Write Operations on](#)

[page 6](#). The bytes that are written are determined by  $\overline{BWS}_0$  and  $\overline{BWS}_1$ , which are sampled with each set of 18-bit data words. Asserting the appropriate Byte Write Select input during the data portion of a write latches the data being presented, and writes it into the device. Deasserting the Byte Write Select input during the data portion of a write enables the data stored in the device for that byte to remain unaltered. This feature can be used to simplify read, modify, or write operations to a byte write operation.

### Single Clock Mode

The CY7C1618KV18 can be used with a single clock that controls both the input and output registers. In this mode, the device recognizes only a single pair of input clocks ( $\overline{K}$  and  $\overline{K}$ ) that control both the input and output registers. This operation is identical to the operation if the device had zero skew between the  $\overline{K}/\overline{K}$  and  $\overline{C}/\overline{C}$  clocks. All timing parameters remain the same in this mode. To use this mode of operation, the user must tie  $\overline{C}$  and  $\overline{C}$  high at power on. This function is a strap option and not alterable during device operation.

### DDR Operation

The CY7C1618KV18 enables high performance operation through high clock frequencies (achieved through pipelining) and DDR mode of operation. The CY7C1618KV18 requires a single No Operation (NOP) cycle during transition from a read to a write cycle. At higher frequencies, some applications may require a second NOP cycle to avoid contention.

If a read occurs after a write cycle, address and data for the write are stored in registers. The write information must be stored because the SRAM cannot perform the last word write to the array, without conflicting with the read. The data stays in this register until the next write cycle occurs. On the first write cycle after the read(s), the stored data from the earlier write is written into the SRAM array. This is called a posted write.

If a read is performed on the same address on which a write is performed in the previous cycle, the SRAM reads out the most current data. The SRAM does this by bypassing the memory array and reading the data from the registers.

### Depth Expansion

Depth expansion requires replicating the  $\overline{LD}$  control signal for each bank. All other control signals can be common between banks as appropriate.

### Programmable Impedance

An external resistor, RQ, must be connected between the ZQ pin on the SRAM and  $V_{SS}$  to enable the SRAM to adjust its output driver impedance. The value of RQ must be  $5 \times$  the value of the intended line impedance driven by the SRAM. The allowable range of RQ to guarantee impedance matching with a tolerance of  $\pm 15$  percent is between  $175 \Omega$  and  $350 \Omega$ , with  $V_{DDQ} = 1.5 \text{ V}$ . The output impedance is adjusted every 1024 cycles upon power up to account for drifts in supply voltage and temperature.

### Echo Clocks

Echo clocks are provided on the DDR II to simplify data capture on high-speed systems. Two echo clocks are generated by the DDR II.  $\overline{CQ}$  is referenced with respect to  $\overline{C}$  and  $\overline{CQ}$  is referenced with respect to  $\overline{C}$ . These are free-running clocks and are synchronized to the output clock of the DDR II. In single clock mode,  $\overline{CQ}$  is generated with respect to  $\overline{K}$  and  $\overline{CQ}$  is generated with respect to  $\overline{K}$ . The timing for the echo clocks is shown in the [Switching Characteristics on page 24](#).

### PLL

These chips use a PLL that is designed to function between 120 MHz and the specified maximum clock frequency. During power up, when the  $\overline{DOFF}$  is tied high, the PLL is locked after  $20 \mu\text{s}$  of stable clock. The PLL can also be reset by slowing or stopping the input clock  $\overline{K}$  and  $\overline{K}$  for a minimum of 30 ns. However, it is not necessary to reset the PLL to lock to the desired frequency. The PLL automatically locks  $20 \mu\text{s}$  after a stable clock is presented. The PLL may be disabled by applying ground to the  $\overline{DOFF}$  pin. When the PLL is turned off, the device behaves in DDR I mode (with one cycle latency and a longer access time).

## Application Example

Figure 2 shows two DDR II used in an application.

**Figure 2. Application Example (Width Expansion)**

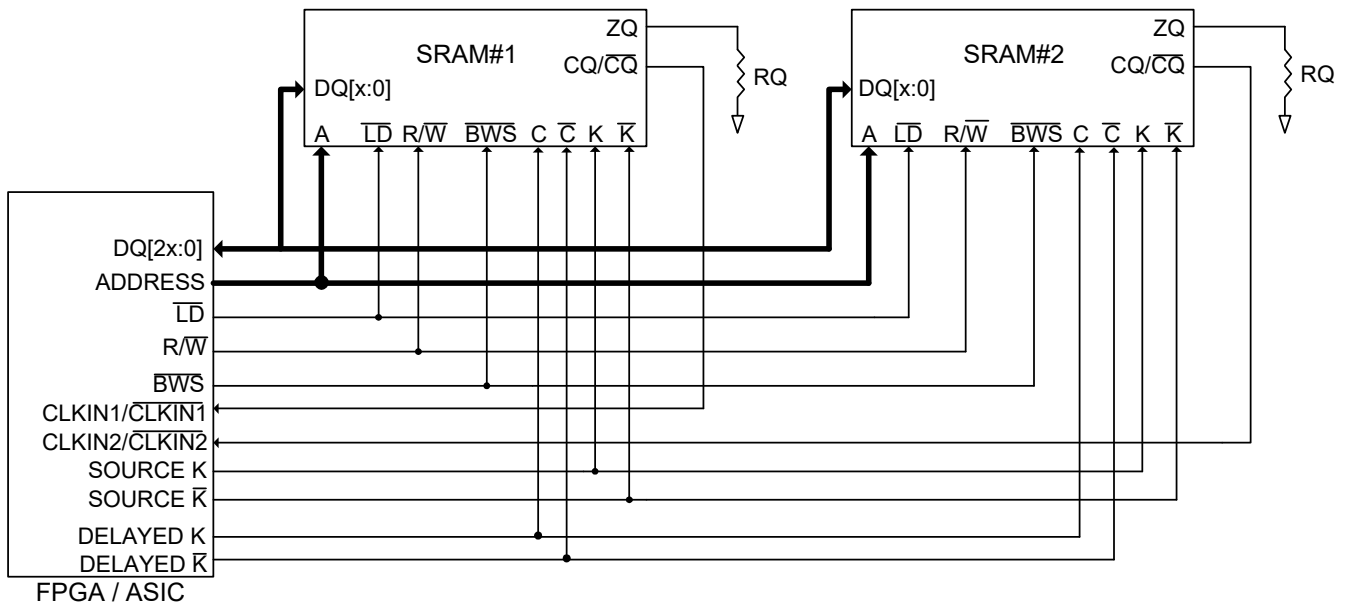

## Truth Table

The truth table for the CY7C1618KV18, and CY7C1620KV18 follow: [2, 3, 4, 5, 6, 7]

Operation	K	$\overline{\text{LD}}$	$\overline{\text{R/W}}$	DQ	DQ
Write cycle: Load address; wait one cycle; input write data on consecutive K and $\overline{\text{K}}$ rising edges.	L–H	L	L	D(A1) at K(t + 1) $\uparrow$	D(A2) at $\overline{\text{K}}$ (t + 1) $\uparrow$
Read cycle: Load address; wait one and a half cycle; read data on consecutive $\overline{\text{C}}$ and C rising edges.	L–H	L	H	Q(A1) at $\overline{\text{C}}$ (t + 1) $\uparrow$	Q(A2) at C(t + 2) $\uparrow$
NOP: No operation	L–H	H	X	High Z	High Z
Standby: Clock stopped	Stopped	X	X	Previous state	Previous state

## Burst Address Table

(CY7C1618KV18, CY7C1620KV18)

First Address (External)	Second Address (Internal)
X..X0	X..X1
X..X1	X..X0

### Notes

- X = "Don't Care," H = Logic HIGH, L = Logic LOW,  $\uparrow$  represents rising edge.
- Device powers up deselected with the outputs in a tristate condition.
- On CY7C1618KV18 and CY7C1620KV18, "A1" represents address location latched by the devices when transaction was initiated and "A2" represents the addresses sequence in the burst.
- "t" represents the cycle at which a read/write operation is started. t + 1 and t + 2 are the first and second clock cycles succeeding the "t" clock cycle.
- Data inputs are registered at K and  $\overline{\text{K}}$  rising edges. Data outputs are delivered on C and  $\overline{\text{C}}$  rising edges, except when in single clock mode.
- Ensure that when clock is stopped K = K and C = C = high. This is not essential, but permits most rapid restart by overcoming transmission line charging symmetrically.

## Write Cycle Descriptions

The write cycle description table for CY7C1618KV18 follows: [8, 9]

$\overline{BWS}_0$	$\overline{BWS}_1$	K	$\overline{K}$	Comments
L	L	L-H	-	During the data portion of a write sequence: CY7C1618KV18 – both bytes ( $D_{[17:0]}$ ) are written into the device.
L	L	-	L-H	During the data portion of a write sequence: CY7C1618KV18 – both bytes ( $D_{[17:0]}$ ) are written into the device.
L	H	L-H	-	During the data portion of a write sequence: CY7C1618KV18 – only the lower byte ( $D_{[8:0]}$ ) is written into the device, $D_{[17:9]}$ remains unaltered.
L	H	-	L-H	During the data portion of a write sequence: CY7C1618KV18 – only the lower byte ( $D_{[8:0]}$ ) is written into the device, $D_{[17:9]}$ remains unaltered.
H	L	L-H	-	During the data portion of a write sequence: CY7C1618KV18 – only the upper byte ( $D_{[17:9]}$ ) is written into the device, $D_{[8:0]}$ remains unaltered.
H	L	-	L-H	During the data portion of a write sequence: CY7C1618KV18 – only the upper byte ( $D_{[17:9]}$ ) is written into the device, $D_{[8:0]}$ remains unaltered.
H	H	L-H	-	No data is written into the devices during this portion of a write operation.
H	H	-	L-H	No data is written into the devices during this portion of a write operation.

### Notes

8. X = "Don't Care," H = Logic HIGH, L = Logic LOW,  $\uparrow$  represents rising edge.

9. Is based on a write cycle that was initiated in accordance with the [Truth Table on page 9](#).  $\overline{BWS}_0$ ,  $\overline{BWS}_1$ ,  $\overline{BWS}_2$ , and  $\overline{BWS}_3$  can be altered on different portions of a write cycle, as long as the setup and hold requirements are achieved.

## Write Cycle Descriptions

The write cycle description table for CY7C1620KV18 follows: [10, 11]

$\overline{\text{BWS}}_0$	$\overline{\text{BWS}}_1$	$\overline{\text{BWS}}_2$	$\overline{\text{BWS}}_3$	K	$\overline{\text{K}}$	Comments
L	L	L	L	L-H	-	During the data portion of a write sequence, all four bytes (D <sub>[35:0]</sub> ) are written into the device.
L	L	L	L	-	L-H	During the data portion of a write sequence, all four bytes (D <sub>[35:0]</sub> ) are written into the device.
L	H	H	H	L-H	-	During the data portion of a write sequence, only the lower byte (D <sub>[8:0]</sub> ) is written into the device. D <sub>[35:9]</sub> remains unaltered.
L	H	H	H	-	L-H	During the data portion of a write sequence, only the lower byte (D <sub>[8:0]</sub> ) is written into the device. D <sub>[35:9]</sub> remains unaltered.
H	L	H	H	L-H	-	During the data portion of a write sequence, only the byte (D <sub>[17:9]</sub> ) is written into the device. D <sub>[8:0]</sub> and D <sub>[35:18]</sub> remains unaltered.
H	L	H	H	-	L-H	During the data portion of a write sequence, only the byte (D <sub>[17:9]</sub> ) is written into the device. D <sub>[8:0]</sub> and D <sub>[35:18]</sub> remains unaltered.
H	H	L	H	L-H	-	During the data portion of a write sequence, only the byte (D <sub>[26:18]</sub> ) is written into the device. D <sub>[17:0]</sub> and D <sub>[35:27]</sub> remains unaltered.
H	H	L	H	-	L-H	During the data portion of a write sequence, only the byte (D <sub>[26:18]</sub> ) is written into the device. D <sub>[17:0]</sub> and D <sub>[35:27]</sub> remains unaltered.
H	H	H	L	L-H	-	During the data portion of a write sequence, only the byte (D <sub>[35:27]</sub> ) is written into the device. D <sub>[26:0]</sub> remains unaltered.
H	H	H	L	-	L-H	During the data portion of a write sequence, only the byte (D <sub>[35:27]</sub> ) is written into the device. D <sub>[26:0]</sub> remains unaltered.
H	H	H	H	L-H	-	No data is written into the device during this portion of a write operation.
H	H	H	H	-	L-H	No data is written into the device during this portion of a write operation.

### Notes

10. X = "Don't Care," H = Logic HIGH, L = Logic LOW, ↑ represents rising edge.

11. Is based on a write cycle that was initiated in accordance with the [Truth Table on page 9](#).  $\overline{\text{BWS}}_0$ ,  $\overline{\text{BWS}}_1$ ,  $\overline{\text{BWS}}_2$ , and  $\overline{\text{BWS}}_3$  can be altered on different portions of a write cycle, as long as the setup and hold requirements are achieved.

## IEEE 1149.1 Serial Boundary Scan (JTAG)

These SRAMs incorporate a serial boundary scan Test Access Port (TAP) in the FBGA package. This part is fully compliant with IEEE Standard 1149.1-2001. The TAP operates using JEDEC standard 1.8 V I/O logic levels.

### Disabling the JTAG Feature

It is possible to operate the SRAM without using the JTAG feature. To disable the TAP controller, TCK must be tied low ( $V_{SS}$ ) to prevent clocking of the device. TDI and TMS are internally pulled up and may be unconnected. They may alternatively be connected to  $V_{DD}$  through a pull-up resistor. TDO must be left unconnected. Upon power up, the device comes up in a reset state, which does not interfere with the operation of the device.

### Test Access Port

#### Test Clock

The test clock is used only with the TAP controller. All inputs are captured on the rising edge of TCK. All outputs are driven from the falling edge of TCK.

#### Test Mode Select (TMS)

The TMS input is used to give commands to the TAP controller and is sampled on the rising edge of TCK. This pin may be left unconnected if the TAP is not used. The pin is pulled up internally, resulting in a Logic HIGH level.

#### Test Data-In (TDI)

The TDI pin is used to serially input information into the registers and can be connected to the input of any of the registers. The instruction loaded into the TAP instruction register, chooses the register between TDI and TDO. For information about loading the instruction register, see the [TAP Controller State Diagram on page 14](#). TDI is internally pulled up and can be unconnected if the TAP is unused in an application. TDI is connected to the most significant bit (MSB) on any register.

#### Test Data-Out (TDO)

The TDO output pin is used to serially clock data out from the registers. The output is active, depending upon the current state of the TAP state machine (see [Instruction Codes on page 18](#)). The output changes on the falling edge of TCK. TDO is connected to the least significant bit (LSB) of any register.

### Performing a TAP Reset

A Reset is performed by forcing TMS high ( $V_{DD}$ ) for five rising edges of TCK. This Reset does not affect the operation of the SRAM and can be performed while the SRAM is operating. At power up, the TAP is reset internally to ensure that TDO comes up in a High Z state.

### TAP Registers

Registers are connected between the TDI and TDO pins to scan the data in and out of the SRAM test circuitry. Only one register can be selected at a time through the instruction registers. Data is serially loaded into the TDI pin on the rising edge of TCK. Data is output on the TDO pin on the falling edge of TCK.

#### Instruction Register

Three-bit instructions can be serially loaded into the instruction register. This register is loaded when it is placed between the TDI and TDO pins, as shown in [TAP Controller Block Diagram on page 15](#). Upon power up, the instruction register is loaded with the IDCODE instruction. It is also loaded with the IDCODE instruction if the controller is placed in a reset state, as described in the previous section.

When the TAP controller is in the Capture-IR state, the two least significant bits are loaded with a binary '01' pattern to enable fault isolation of the board level serial test path.

#### Bypass Register

To save time when serially shifting data through registers, you can skip certain chips. The bypass register is a single-bit register that is placed between TDI and TDO pins. This enables shifting of data through the SRAM with minimal delay. The bypass register is set low ( $V_{SS}$ ) when the BYPASS instruction is executed.

#### Boundary Scan Register

The boundary scan register is connected to all of the input and output pins on the SRAM. Several No Connect (NC) pins are also included in the scan register to reserve pins for higher density devices.

The boundary scan register is loaded with the contents of the RAM input and output ring when the TAP controller is in the Capture-DR state and is then placed between the TDI and TDO pins when the controller is moved to the Shift-DR state. The EXTEST, SAMPLE/PRELOAD, and SAMPLE Z instructions can be used to capture the contents of the input and output ring.

The [Boundary Scan Order on page 19](#) shows the order in which the bits are connected. Each bit corresponds to one of the bumps on the SRAM package. The MSB of the register is connected to TDI, and the LSB is connected to TDO.

#### Identification (ID) Register

The ID register is loaded with a vendor-specific, 32-bit code during the Capture-DR state when the IDCODE command is loaded in the instruction register. The IDCODE is hardwired into the SRAM and can be shifted out when the TAP controller is in the Shift-DR state. The ID register has a vendor code and other information described in [Identification Register Definitions on page 18](#).

### TAP Instruction Set

Eight different instructions are possible with the three-bit instruction register. All combinations are listed in [Instruction Codes on page 18](#). Three of these instructions are listed as RESERVED and cannot be used. The other five instructions are described in this section in detail.

Instructions are loaded into the TAP controller during the Shift-IR state when the instruction register is placed between TDI and TDO. During this state, instructions are shifted through the instruction register through the TDI and TDO pins. To execute the instruction after it is shifted in, the TAP controller is moved into the Update-IR state.

### *IDCODE*

The IDCODE instruction loads a vendor-specific, 32-bit code into the instruction register. It also places the instruction register between the TDI and TDO pins and shifts the IDCODE out of the device when the TAP controller enters the Shift-DR state. The IDCODE instruction is loaded into the instruction register at power up or whenever the TAP controller is supplied a Test-Logic-Reset state.

### *SAMPLE Z*

The SAMPLE Z instruction connects the boundary scan register between the TDI and TDO pins when the TAP controller is in a Shift-DR state. The SAMPLE Z command puts the output bus into a High Z state until the next command is supplied during the Update IR state.

### *SAMPLE/PRELOAD*

SAMPLE/PRELOAD is a 1149.1 mandatory instruction. When the SAMPLE/PRELOAD instructions are loaded into the instruction register and the TAP controller is in the Capture-DR state, a snapshot of data on the input and output pins is captured in the boundary scan register.

The TAP controller clock only operates at a frequency up to 20 MHz, while the SRAM clock operates more than an order of magnitude faster. Since there is a large difference in the clock frequencies, it is possible that during the Capture-DR state, an input or output undergoes a transition. The TAP may then try to capture a signal while in transition (metastable state). This does not harm the device, but there is no guarantee to the value that is captured. Repeatable results may not be possible.

To guarantee that the boundary scan register captures the correct value of a signal, the SRAM signal must be stabilized long enough to meet the TAP controller's capture setup plus hold times ( $t_{CS}$  and  $t_{CH}$ ). The SRAM clock input might not be captured correctly if the design does not stop (or slow) the clock during a SAMPLE/PRELOAD instruction. If this is an issue, it is still possible to capture all other signals and simply ignore the value of the CK and CK captured in the boundary scan register.

After the data is captured, it is possible to shift out the data by putting the TAP into the Shift-DR state. This places the boundary scan register between the TDI and TDO pins.

PRELOAD places an initial data pattern at the latched parallel outputs of the boundary scan register cells before the selection of another boundary scan test operation.

The shifting of data for the SAMPLE and PRELOAD phases occurs concurrently when required, that is, while the data captured is shifted out, the preloaded data can be shifted in.

### *BYPASS*

When the BYPASS instruction is loaded in the instruction register and the TAP is placed in a Shift-DR state, the bypass register is placed between the TDI and TDO pins. The advantage of the BYPASS instruction is that it shortens the boundary scan path when multiple devices are connected together on a board.

### *EXTEST*

The EXTEST instruction drives the preloaded data out through the system output pins. This instruction also connects the boundary scan register for serial access between the TDI and TDO in the Shift-DR controller state.

### *EXTEST OUTPUT BUS TRISTATE*

IEEE Standard 1149.1 mandates that the TAP controller be able to put the output bus into a tristate mode.

The boundary scan register has a special bit located at bit 108. When this scan cell, called the 'extest output bus tristate', is latched into the preload register during the Update-DR state in the TAP controller, it directly controls the state of the output (Q-bus) pins, when the EXTEST is entered as the current instruction. When high, it enables the output buffers to drive the output bus. When low, this bit places the output bus into a High Z condition.

This bit can be set by entering the SAMPLE/PRELOAD or EXTEST command, and then shifting the desired bit into that cell, during the Shift-DR state. During Update-DR, the value loaded into that shift-register cell latches into the preload register. When the EXTEST instruction is entered, this bit directly controls the output Q-bus pins. Note that this bit is preset high to enable the output when the device is powered up, and also when the TAP controller is in the Test-Logic-Reset state.

### *Reserved*

These instructions are not implemented but are reserved for future use. Do not use these instructions.

## TAP Controller State Diagram

The state diagram for the TAP controller follows. <sup>[12]</sup>

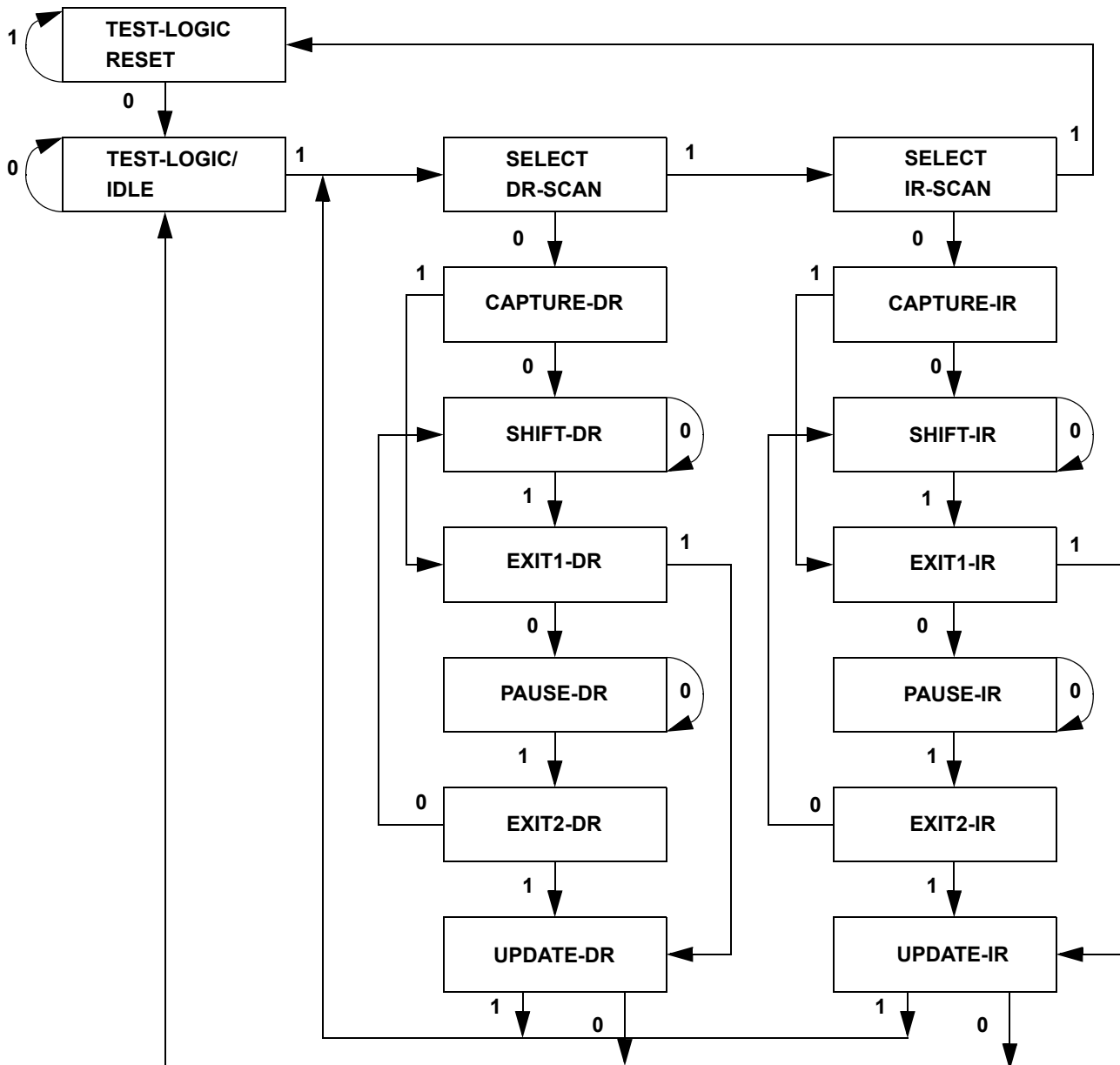

**Note**

12. The 0/1 next to each state represents the value at TMS at the rising edge of TCK.

## TAP Controller Block Diagram

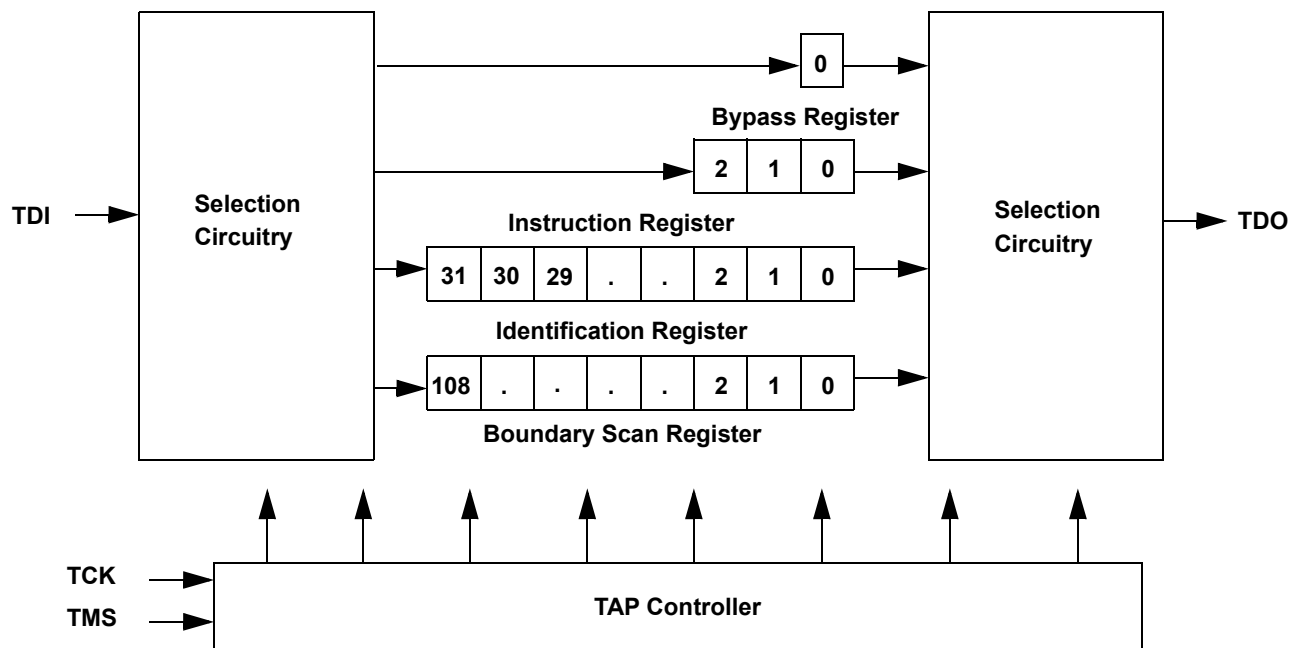

## TAP Electrical Characteristics

Over the Operating Range

Parameter [13, 14, 15]	Description	Test Conditions	Min	Max	Unit
$V_{OH1}$	Output high voltage	$I_{OH} = -2.0 \text{ mA}$	1.4	–	V
$V_{OH2}$	Output high voltage	$I_{OH} = -100 \mu\text{A}$	1.6	–	V
$V_{OL1}$	Output low voltage	$I_{OL} = 2.0 \text{ mA}$	–	0.4	V
$V_{OL2}$	Output low voltage	$I_{OL} = 100 \mu\text{A}$	–	0.2	V
$V_{IH}$	Input high voltage	–	$0.65 \times V_{DD}$	$V_{DD} + 0.3$	V
$V_{IL}$	Input low voltage	–	–0.3	$0.35 \times V_{DD}$	V
$I_X$	Input and output load current	$GND \leq V_I \leq V_{DD}$	–5	5	$\mu\text{A}$

### Notes

13. These characteristics pertain to the TAP inputs (TMS, TCK, TDI and TDO). Parallel load levels are specified in the [Electrical Characteristics on page 21](#).

14. Overshoot:  $V_{IH(AC)} < V_{DD} + 0.85 \text{ V}$  (Pulse width less than  $t_{CYC}/2$ ), Undershoot:  $V_{IL(AC)} > -1.5 \text{ V}$  (Pulse width less than  $t_{CYC}/2$ ).

15. All voltage referenced to ground.

## TAP AC Switching Characteristics

Over the Operating Range

Parameter <sup>[16, 17]</sup>	Description	Min	Max	Unit
$t_{TCYC}$	TCK clock cycle time	50	–	ns
$t_{TF}$	TCK clock frequency	–	20	MHz
$t_{TH}$	TCK clock high	20	–	ns
$t_{TL}$	TCK clock low	20	–	ns
<b>Setup Times</b>				
$t_{TMSS}$	TMS setup to TCK clock rise	5	–	ns
$t_{TDIS}$	TDI setup to TCK clock rise	5	–	ns
$t_{CS}$	Capture setup to TCK rise	5	–	ns
<b>Hold Times</b>				
$t_{TMSh}$	TMS hold after TCK clock rise	5	–	ns
$t_{TDIH}$	TDI hold after clock rise	5	–	ns
$t_{CH}$	Capture hold after clock rise	5	–	ns
<b>Output Times</b>				
$t_{TDOV}$	TCK clock low to TDO valid	–	10	ns
$t_{TDOX}$	TCK clock low to TDO invalid	0	–	ns

### Notes

16.  $t_{CS}$  and  $t_{CH}$  refer to the setup and hold time requirements of latching data from the boundary scan register.

17. Test conditions are specified using the load in TAP AC Test Conditions.  $t_P/t_F = 1$  ns.

### TAP Timing and Test Conditions

Figure 3 shows the TAP timing and test conditions. [18]

Figure 3. TAP Timing and Test Conditions

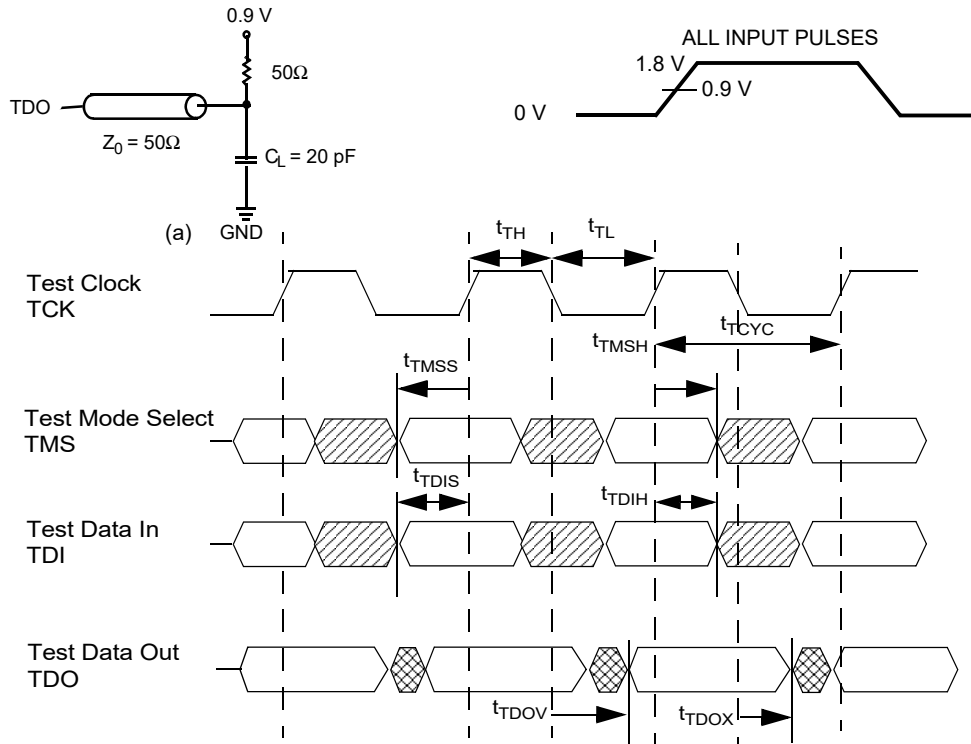

**Note**

18. Test conditions are specified using the load in TAP AC Test Conditions.  $t_R/t_F = 1 \text{ ns}$ .

## Identification Register Definitions

Instruction Field	Value		Description
	CY7C1618KV18	CY7C1620KV18	
Revision number (31:29)	000	000	Version number.
Cypress device ID (28:12)	11010100010010011	11010100010100011	Defines the type of SRAM.
Cypress JEDEC ID (11:1)	00000110100	00000110100	Allows unique identification of SRAM vendor.
ID register presence (0)	1	1	Indicates the presence of an ID register.

## Scan Register Sizes

Register Name	Bit Size
Instruction	3
Bypass	1
ID	32
Boundary Scan	109

## Instruction Codes

Instruction	Code	Description
EXTEST	000	Captures the input and output ring contents.
IDCODE	001	Loads the ID register with the vendor ID code and places the register between TDI and TDO. This operation does not affect SRAM operation.
SAMPLE Z	010	Captures the input and output contents. Places the boundary scan register between TDI and TDO. Forces all SRAM output drivers to a High Z state.
RESERVED	011	Do Not Use: This instruction is reserved for future use.
SAMPLE/PRELOAD	100	Captures the input and output ring contents. Places the boundary scan register between TDI and TDO. Does not affect the SRAM operation.
RESERVED	101	Do Not Use: This instruction is reserved for future use.
RESERVED	110	Do Not Use: This instruction is reserved for future use.
BYPASS	111	Places the bypass register between TDI and TDO. This operation does not affect SRAM operation.

**Boundary Scan Order**

Bit No.	Bump ID
0	6R
1	6P
2	6N
3	7P
4	7N
5	7R
6	8R
7	8P
8	9R
9	11P
10	10P
11	10N
12	9P
13	10M
14	11N
15	9M
16	9N
17	11L
18	11M
19	9L
20	10L
21	11K
22	10K
23	9J
24	9K
25	10J
26	11J
27	11H

Bit No.	Bump ID
28	10G
29	9G
30	11F
31	11G
32	9F
33	10F
34	11E
35	10E
36	10D
37	9E
38	10C
39	11D
40	9C
41	9D
42	11B
43	11C
44	9B
45	10B
46	11A
47	10A
48	9A
49	8B
50	7C
51	6C
52	8A
53	7A
54	7B
55	6B

Bit No.	Bump ID
56	6A
57	5B
58	5A
59	4A
60	5C
61	4B
62	3A
63	2A
64	1A
65	2B
66	3B
67	1C
68	1B
69	3D
70	3C
71	1D
72	2C
73	3E
74	2D
75	2E
76	1E
77	2F
78	3F
79	1G
80	1F
81	3G
82	2G
83	1H

Bit No.	Bump ID
84	1J
85	2J
86	3K
87	3J
88	2K
89	1K
90	2L
91	3L
92	1M
93	1L
94	3N
95	3M
96	1N
97	2M
98	3P
99	2N
100	2P
101	1P
102	3R
103	4R
104	4P
105	5P
106	5N
107	5R
108	Internal

### Power Up Sequence in DDR II SRAM

DDR II SRAMs must be powered up and initialized in a predefined manner to prevent undefined operations.

#### Power Up Sequence

- Apply power and drive  $\overline{\text{DOFF}}$  either high or low (all other inputs can be high or low).
  - Apply  $V_{\text{DD}}$  before  $V_{\text{DDQ}}$ .
  - Apply  $V_{\text{DDQ}}$  before  $V_{\text{REF}}$  or at the same time as  $V_{\text{REF}}$ .
  - Drive  $\overline{\text{DOFF}}$  high.
- Provide stable  $\overline{\text{DOFF}}$  (high), power and clock (K,  $\overline{\text{K}}$ ) for 20  $\mu\text{s}$  to lock the PLL

#### PLL Constraints

- PLL uses K clock as its synchronizing input. The input must have low phase jitter, which is specified as  $t_{\text{KC Var}}$ .
- The PLL functions at frequencies down to 120 MHz.
- If the input clock is unstable and the PLL is enabled, then the PLL may lock onto an incorrect frequency, causing unstable SRAM behavior. To avoid this, provide 20  $\mu\text{s}$  of stable clock to relock to the desired clock frequency.

Figure 4. Power Up Waveforms

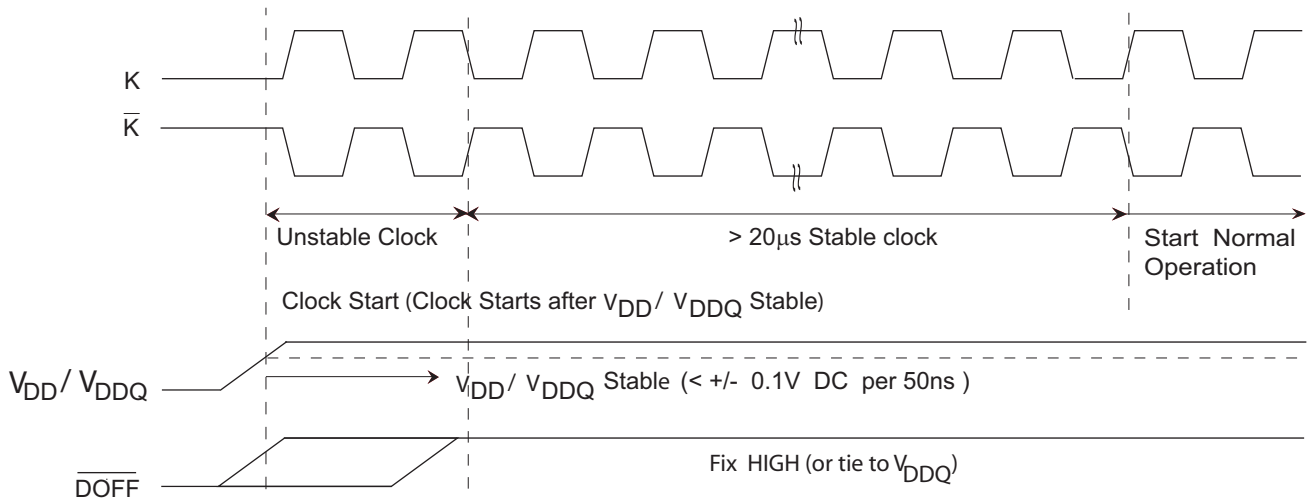

## Maximum Ratings

Exceeding maximum ratings may impair the useful life of the device. These user guidelines are not tested.

Storage temperature ..... -65 °C to +150 °C

Ambient temperature  
with power applied ..... -55 °C to +125 °C

Supply voltage on V<sub>DD</sub> relative to GND ..... -0.5 V to +2.9 V

Supply voltage on V<sub>DDQ</sub> relative to GND ..... -0.5 V to +V<sub>DD</sub>

DC applied to outputs in High Z ..... -0.5 V to V<sub>DDQ</sub> + 0.3 V

DC input voltage <sup>[19]</sup> ..... -0.5 V to V<sub>DD</sub> + 0.3 V

Current into outputs (Low) ..... 20 mA

Static discharge voltage  
(MIL-STD-883, M. 3015) ..... > 2001 V

Latch up current ..... > 200 mA

## Operating Range

Range	Ambient Temperature (T <sub>A</sub> )	V <sub>DD</sub> <sup>[20]</sup>	V <sub>DDQ</sub> <sup>[20]</sup>
Commercial	0 °C to +70 °C	1.8 ± 0.1 V	1.4 V to V <sub>DD</sub>
Industrial	-40 °C to +85 °C		

## Neutron Soft Error Immunity

Parameter	Description	Test Conditions	Typ	Max*	Unit
LSBU	Logical single-bit upsets	25 °C	197	216	FIT/Mb
LMBU	Logical multi-bit upsets	25 °C	0	0.01	FIT/Mb
SEL	Single event latch up	85 °C	0	0.1	FIT/Dev

\* No LMBU or SEL events occurred during testing; this column represents a statistical  $\chi^2$ , 95% confidence limit calculation. For more details refer to Application Note Accelerated Neutron SER Testing and Calculation of Terrestrial Failure Rates – AN54908.

## Electrical Characteristics

Over the Operating Range

### DC Electrical Characteristics

Over the Operating Range

Parameter <sup>[21]</sup>	Description	Test Conditions	Min	Typ	Max	Unit
V <sub>DD</sub>	Power supply voltage		1.7	1.8	1.9	V
V <sub>DDQ</sub>	I/O supply voltage		1.4	1.5	V <sub>DD</sub>	V
V <sub>OH</sub>	Output high voltage	Note 22	V <sub>DDQ</sub> /2 - 0.12	-	V <sub>DDQ</sub> /2 + 0.12	V
V <sub>OL</sub>	Output low voltage	Note 23	V <sub>DDQ</sub> /2 - 0.12	-	V <sub>DDQ</sub> /2 + 0.12	V
V <sub>OH(Low)</sub>	Output high voltage	I <sub>OH</sub> = -0.1 mA, Nominal impedance	V <sub>DDQ</sub> - 0.2	-	V <sub>DDQ</sub>	V
V <sub>OL(Low)</sub>	Output low voltage	I <sub>OL</sub> = 0.1 mA, Nominal impedance	V <sub>SS</sub>	-	0.2	V
V <sub>IH</sub>	Input high voltage		V <sub>REF</sub> + 0.1	-	V <sub>DDQ</sub> + 0.3	V
V <sub>IL</sub>	Input low voltage		-0.3	-	V <sub>REF</sub> - 0.1	V
I <sub>X</sub>	Input leakage current	GND ≤ V <sub>I</sub> ≤ V <sub>DDQ</sub>	-5	-	5	μA
I <sub>OZ</sub>	Output leakage current	GND ≤ V <sub>I</sub> ≤ V <sub>DDQ</sub> , Output disabled	-5	-	5	μA
V <sub>REF</sub>	Input reference voltage <sup>[24]</sup>	Typical Value = 0.75 V	0.68	0.75	0.95	V

### Notes

19. Overshoot: V<sub>IH(AC)</sub> < V<sub>DDQ</sub> + 0.85 V (Pulse width less than t<sub>CYC/2</sub>), Undershoot: V<sub>IL(AC)</sub> > -1.5 V (Pulse width less than t<sub>CYC/2</sub>).

20. Power up: assumes a linear ramp from 0 V to V<sub>DD(min)</sub> within 200 ms. During this time V<sub>IH</sub> < V<sub>DD</sub> and V<sub>DDQ</sub> ≤ V<sub>DD</sub>.

21. All voltage referenced to ground.

22. Outputs are impedance controlled. I<sub>OH</sub> = -(V<sub>DDQ</sub>/2)/(RQ/5) for values of 175 Ω ≤ RQ ≤ 350 Ω.

23. Outputs are impedance controlled. I<sub>OL</sub> = (V<sub>DDQ</sub>/2)/(RQ/5) for values of 175 Ω ≤ RQ ≤ 350 Ω.

24. V<sub>REF(min)</sub> = 0.68 V or 0.45 V<sub>DDQ</sub>, whichever is larger, V<sub>REF(max)</sub> = 0.95 V or 0.54 V<sub>DDQ</sub>, whichever is smaller.

**Electrical Characteristics** (continued)

Over the Operating Range

**DC Electrical Characteristics** (continued)

Over the Operating Range

Parameter <sup>[21]</sup>	Description	Test Conditions	Min	Typ	Max	Unit		
I <sub>DD</sub> <sup>[25]</sup>	V <sub>DD</sub> operating supply	V <sub>DD</sub> = Max, I <sub>OUT</sub> = 0 mA, f = f <sub>MAX</sub> = 1/t <sub>CYC</sub>	333 MHz	(× 18)	–	–	650	mA
				(× 36)	–	–	790	
			300 MHz	(× 18)	–	–	610	mA
			250 MHz	(× 36)	–	–	660	mA
I <sub>SB1</sub>	Automatic Power Down Current	Max V <sub>DD</sub> , Both Ports Deselected, V <sub>IN</sub> ≥ V <sub>IH</sub> or V <sub>IN</sub> ≤ V <sub>IL</sub> , f = f <sub>MAX</sub> = 1/t <sub>CYC</sub> , Inputs Static	333 MHz	(× 18)	–	–	410	mA
				(× 36)	–	–	410	
			300 MHz	(× 18)	–	–	390	mA
			250 MHz	(× 36)	–	–	370	mA

**Note**

25. The operation current is calculated with 50% read cycle and 50% write cycle.

## AC Electrical Characteristics

Over the Operating Range

Parameter <sup>[26]</sup>	Description	Test Conditions	Min	Typ	Max	Unit
V <sub>IH</sub>	Input high voltage		V <sub>REF</sub> + 0.2	–	–	V
V <sub>IL</sub>	Input low voltage		–	–	V <sub>REF</sub> – 0.2	V

## Capacitance

Parameter <sup>[27]</sup>	Description	Test Conditions	Max	Unit
C <sub>IN</sub>	Input capacitance	T <sub>A</sub> = 25 °C, f = 1 MHz, V <sub>DD</sub> = 1.8 V, V <sub>DDQ</sub> = 1.5 V	4	pF
C <sub>O</sub>	Output capacitance		4	pF

## Thermal Resistance

Parameter <sup>[27]</sup>	Description	Test Conditions	165-ball FBGA Package	Unit
Θ <sub>JA</sub> (0 m/s)	Thermal resistance (junction to ambient)	Socketed on a 170 × 220 × 2.35 mm, eight-layer printed circuit board	12.23	°C/W
Θ <sub>JA</sub> (1 m/s)			11.17	°C/W
Θ <sub>JA</sub> (3 m/s)			10.42	°C/W
Θ <sub>JB</sub>	Thermal resistance (junction to board)		9.34	°C/W
Θ <sub>JC</sub>	Thermal resistance (junction to case)		2.10	°C/W

## AC Test Loads and Waveforms

Figure 5. AC Test Loads and Waveforms

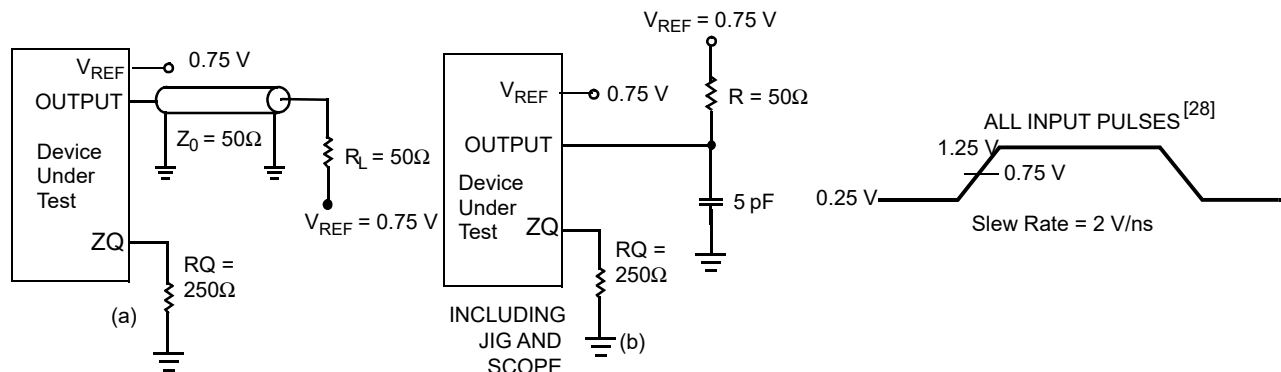

### Notes

26. Overshoot: V<sub>IH(AC)</sub> < V<sub>DDQ</sub> + 0.85 V (Pulse width less than t<sub>CYC/2</sub>), Undershoot: V<sub>IL(AC)</sub> > –1.5 V (Pulse width less than t<sub>CYC/2</sub>).

27. Tested initially and after any design or process change that may affect these parameters.

28. Unless otherwise noted, test conditions assume signal transition time of 2 V/ns, timing reference levels of 0.75 V, V<sub>REF</sub> = 0.75 V, R<sub>Q</sub> = 250 Ω, V<sub>DDQ</sub> = 1.5 V, input pulse levels of 0.25 V to 1.25 V, and output loading of the specified I<sub>OL</sub>/I<sub>OH</sub> and load capacitance shown in (a) of Figure 5.

## Switching Characteristics

Over the Operating Range

Parameters <sup>[29, 30]</sup>		Description	333 MHz		300 MHz		250 MHz		Unit
Cypress Parameter	Consortium Parameter		Min	Max	Min	Max	Min	Max	
t <sub>POWER</sub>		V <sub>DD(typical)</sub> to the first access <sup>[31]</sup>	1	–	1	–	1	–	ms
t <sub>CYC</sub>	t <sub>KHKH</sub>	K clock and C clock cycle time	3.0	8.4	3.3	8.4	4.0	8.4	ns
t <sub>KH</sub>	t <sub>KHKL</sub>	Input clock (K/ $\bar{K}$ ; C/ $\bar{C}$ ) high	1.20	–	1.32	–	1.6	–	ns
t <sub>KL</sub>	t <sub>KLKH</sub>	Input clock (K/ $\bar{K}$ ; C/ $\bar{C}$ ) low	1.20	–	1.32	–	1.6	–	ns
t <sub>KH<math>\bar{K}</math>H</sub>	t <sub>KH<math>\bar{K}</math>H</sub>	K clock rise to $\bar{K}$ clock rise and C to $\bar{C}$ rise (rising edge to rising edge)	1.35	–	1.49	–	1.8	–	ns
t <sub>KHCH</sub>	t <sub>KHCH</sub>	K/ $\bar{K}$ clock rise to C/ $\bar{C}$ clock rise (rising edge to rising edge)	0.0	1.30	0.0	1.45	0.0	1.8	ns
<b>Setup Times</b>									
t <sub>SA</sub>	t <sub>AVKH</sub>	Address setup to K clock rise	0.4	–	0.4	–	0.5	–	ns
t <sub>SC</sub>	t <sub>IVKH</sub>	Control setup to K clock rise ( $\bar{RPS}$ , $\bar{WPS}$ )	0.4	–	0.4	–	0.5	–	ns
t <sub>SCDDR</sub>	t <sub>IVKH</sub>	Double data rate control setup to clock (K/ $\bar{K}$ ) rise ( $\bar{BWS}_0$ , $\bar{BWS}_1$ , $\bar{BWS}_2$ , $\bar{BWS}_3$ )	0.3	–	0.3	–	0.35	–	ns
t <sub>SD</sub>	t <sub>DVKH</sub>	D <sub>[X:0]</sub> setup to clock (K/ $\bar{K}$ ) rise	0.3	–	0.3	–	0.35	–	ns
<b>Hold Times</b>									
t <sub>HA</sub>	t <sub>KHAX</sub>	Address hold after K clock rise	0.4	–	0.4	–	0.5	–	ns
t <sub>HC</sub>	t <sub>KHIX</sub>	Control hold after K clock rise ( $\bar{RPS}$ , $\bar{WPS}$ )	0.4	–	0.4	–	0.5	–	ns
t <sub>HCDDR</sub>	t <sub>KHIX</sub>	DDR control hold after clock (K/ $\bar{K}$ ) rise ( $\bar{BWS}_0$ , $\bar{BWS}_1$ , $\bar{BWS}_2$ , $\bar{BWS}_3$ )	0.3	–	0.3	–	0.35	–	ns
t <sub>HD</sub>	t <sub>KHDX</sub>	D <sub>[X:0]</sub> hold after Clock (K/ $\bar{K}$ ) rise	0.3	–	0.3	–	0.35	–	ns

### Notes

29. Unless otherwise noted, test conditions assume signal transition time of 2 V/ns, timing reference levels of 0.75 V, V<sub>REF</sub> = 0.75 V, R<sub>Q</sub> = 250 Ω, V<sub>DDQ</sub> = 1.5 V, input pulse levels of 0.25 V to 1.25 V, and output loading of the specified I<sub>OL</sub>/I<sub>OH</sub> and load capacitance shown in (a) of [Figure 5 on page 23](#).

30. When a part with a maximum frequency above 167 MHz is operating at a lower clock frequency, it requires the input timings of the frequency range in which it is being operated and outputs data with the output timings of that frequency range.

31. This part has an internal voltage regulator; t<sub>POWER</sub> is the time that the power is supplied above V<sub>DD</sub> min initially before a read or write operation can be initiated.

**Switching Characteristics** (continued)

Over the Operating Range

Parameters <sup>[29, 30]</sup>		Description	333 MHz		300 MHz		250 MHz		Unit
Cypress Parameter	Consortium Parameter		Min	Max	Min	Max	Min	Max	
<b>Output Times</b>									
t <sub>CO</sub>	t <sub>CHQV</sub>	C/ $\bar{C}$ clock rise (or K/ $\bar{K}$ in single clock mode) to data valid	–	0.45	–	0.45	–	0.45	ns
t <sub>DOH</sub>	t <sub>CHQX</sub>	Data output hold after output C/ $\bar{C}$ clock rise (active to active)	–0.45	–	–0.45	–	–0.45	–	ns
t <sub>CCQO</sub>	t <sub>CHCQV</sub>	C/ $\bar{C}$ clock rise to echo clock valid	–	0.45	–	0.45	–	0.45	ns
t <sub>CQOH</sub>	t <sub>CHCQX</sub>	Echo clock hold after C/ $\bar{C}$ clock rise	–0.45	–	–0.45	–	–0.45	–	ns
t <sub>CQD</sub>	t <sub>CQHQV</sub>	Echo clock high to data valid	–	0.25	–	0.27	–	0.30	ns
t <sub>CQDOH</sub>	t <sub>CQHQX</sub>	Echo clock high to data invalid	–0.25	–	–0.27	–	–0.30	–	ns
t <sub>CQH</sub>	t <sub>CQHQCQL</sub>	Output clock (CQ/ $\bar{CQ}$ ) high <sup>[32]</sup>	1.25	–	1.40	–	1.75	–	ns
t <sub>CQH<math>\bar{CQ}</math>H</sub>	t <sub>CQH<math>\bar{CQ}</math>H</sub>	CQ clock rise to $\bar{CQ}$ clock rise (rising edge to rising edge) <sup>[32]</sup>	1.25	–	1.40	–	1.75	–	ns
t <sub>CHZ</sub>	t <sub>CHQZ</sub>	Clock (C/ $\bar{C}$ ) rise to High Z (Active to High Z) <sup>[33, 34]</sup>	–	0.45	–	0.45	–	0.45	ns
t <sub>CLZ</sub>	t <sub>CHQX1</sub>	Clock (C/ $\bar{C}$ ) rise to Low Z <sup>[33, 34]</sup>	–0.45	–	–0.45	–	–0.45	–	ns
<b>PLL Timing</b>									
t <sub>KC Var</sub>	t <sub>KC Var</sub>	Clock phase jitter	–	0.20	–	0.20	–	0.20	ns
t <sub>KC lock</sub>	t <sub>KC lock</sub>	PLL lock time (K, C)	20	–	20	–	20	–	μs
t <sub>KC Reset</sub>	t <sub>KC Reset</sub>	K static to PLL reset	30	–	30	–	30	–	ns

**Notes**

32. These parameters are extrapolated from the input timing parameters (t<sub>CYC</sub>/2 – 250 ps, where 250 ps is the internal jitter). These parameters are only guaranteed by design and are not tested in production.

33. t<sub>CHZ</sub>, t<sub>CLZ</sub> are specified with a load capacitance of 5 pF as in (b) of Figure 5 on page 23. Transition is measured ±100 mV from steady-state voltage.

34. At any voltage and temperature t<sub>CHZ</sub> is less than t<sub>CLZ</sub> and t<sub>CHZ</sub> less than t<sub>CO</sub>.

## Switching Waveforms

### Read/Write/Deselect Sequence

Figure 6. Read/Write/Deselect Sequence [35, 36, 37]

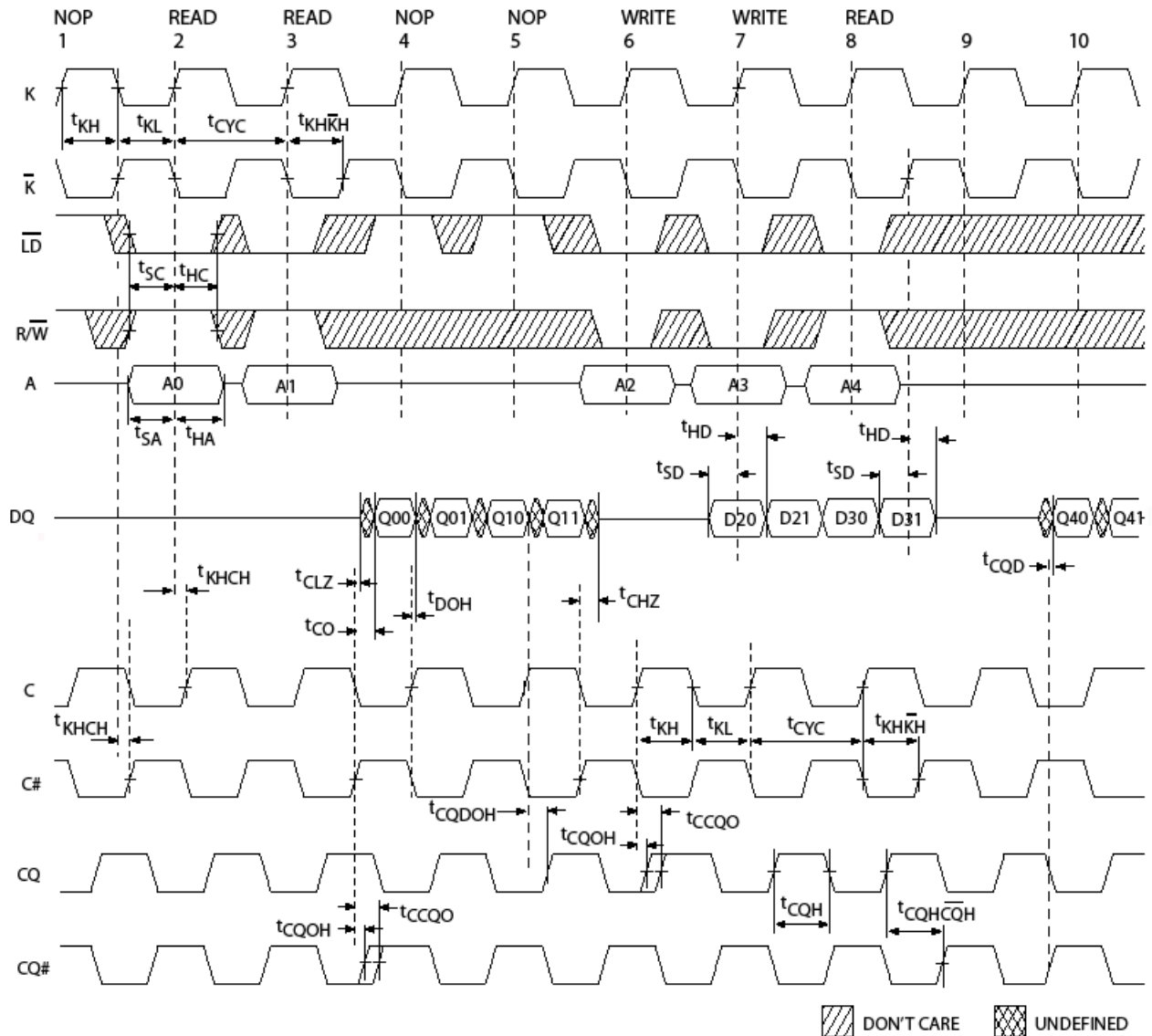

#### Notes

35. Q00 refers to output from address A0. Q01 refers to output from the next internal burst address following A0, that is, A0 + 1.

36. Outputs are disabled (High Z) one clock cycle after a NOP.

37. In this example, if address A4 = A3, then data Q40 = D30 and Q41 = D31. Write data is forwarded immediately as read results. This note applies to the whole diagram.

### Ordering Information

The following table contains only the parts that are currently available. If you do not see what you are looking for, contact your local sales representative. For more information, visit the Cypress website at [www.cypress.com](http://www.cypress.com) and refer to the product summary page at <http://www.cypress.com/products>.

Cypress maintains a worldwide network of offices, solution centers, manufacturer’s representatives and distributors. To find the office closest to you, visit us at <http://www.cypress.com/go/datasheet/offices>.

Speed (MHz)	Ordering Code	Package Diagram	Package Type	Operating Range
250	CY7C1620KV18-250BZXC	51-85195	165-ball FBGA (15 × 17 × 1.4 mm) Pb-free	Commercial
300	CY7C1618KV18-300BZXC	51-85195	165-ball FBGA (15 × 17 × 1.4 mm) Pb-free	Commercial
333	CY7C1618KV18-333BZXC	51-85195	165-ball FBGA (15 × 17 × 1.4 mm) Pb-free	Commercial
	CY7C1620KV18-333BZXI			Industrial

### Ordering Code Definitions

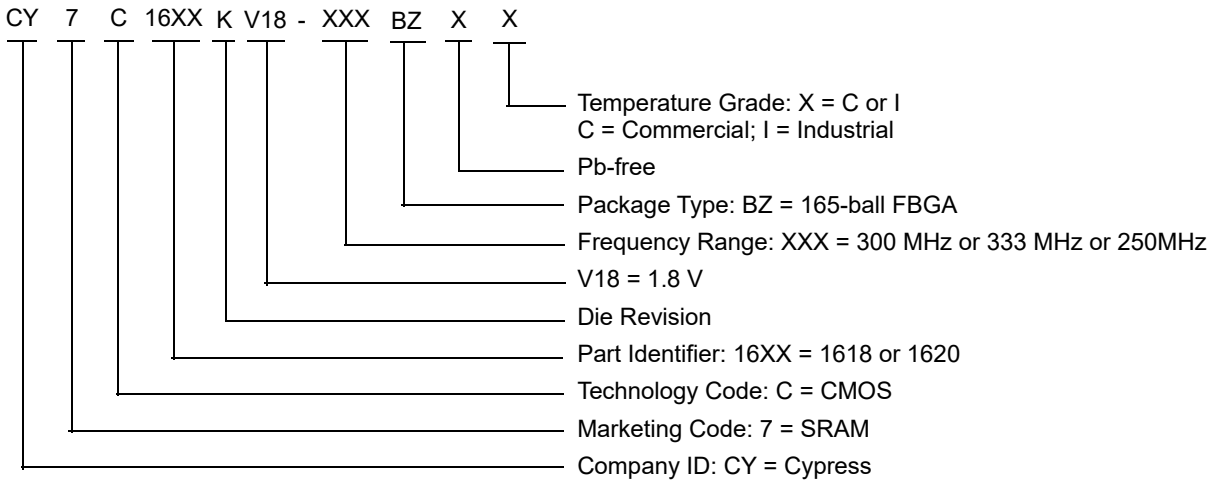

Package Diagram

Figure 7. 165-ball FBGA (15 × 17 × 1.40 mm (0.50 Ball Diameter)) Package Outline, 51-85195

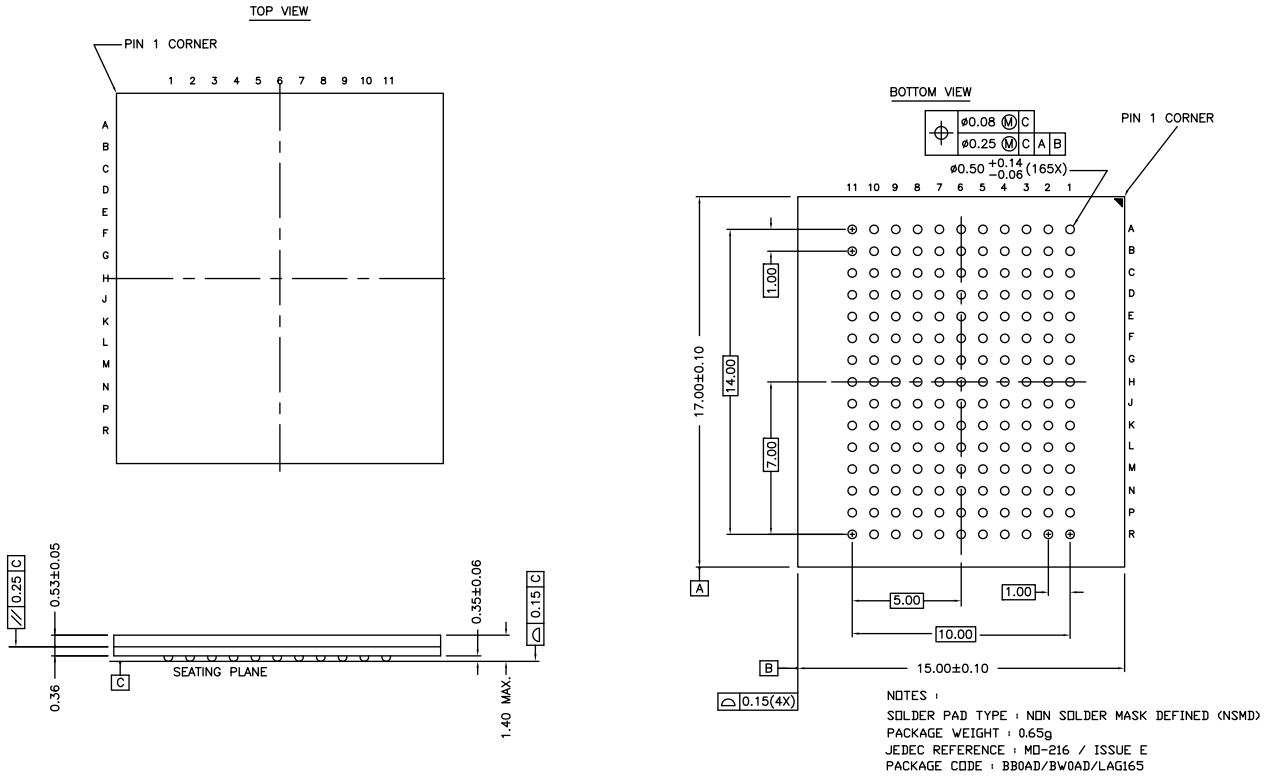

51-85195 \*E

## Acronyms

Acronym	Description
BWS	Byte Write Select
DDR	Double Data Rate
DLL	Delay Lock Loop
FBGA	Fine-Pitch Ball Grid Array
HSTL	High-Speed Transceiver Logic
I/O	Input/Output
JTAG	Joint Test Action Group
LSB	Least Significant Bit
LSBU	Logical Single-Bit Upsets
LMBU	Logical Multi-Bit Upsets
MSB	Most Significant Bit
PLL	Phase Locked Loop
QDR	Quad Data Rate
SEL	Single Event Latch-up
SRAM	Static Random Access Memory
TAP	Test Access Port
TCK	Test Clock
TDI	Test Data-In
TDO	Test Data-Out
TMS	Test Mode Select

## Document Conventions

### Units of Measure

Symbol	Unit of Measure
°C	degree Celsius
FIT/Dev	failure in time per device
FIT/Mb	failure in time per mega bit
MHz	megahertz
μA	microampere
μs	microsecond
mA	milliampere
mm	millimeter
ms	millisecond
ns	nanosecond
Ω	ohm
%	percent
pF	picofarad
V	volt
W	watt

**Document History Page**

Document Title: CY7C1618KV18/CY7C1620KV18, 144-Mbit DDR II SRAM Two-Word Burst Architecture			
Document Number: 001-44274			
Rev.	ECN No.	Submission Date	Description of Change
**	1961327	See ECN	New data sheet.
*A	2555945	08/22/08	Updated <a href="#">Identification Register Definitions</a> (Changed Revision Number (31:29) from 001 to 000). Updated <a href="#">Power Up Sequence in DDR II SRAM</a> (description and <a href="#">Figure 4</a> ). Updated <a href="#">Maximum Ratings</a> (Changed Ambient Temperature with Power Applied from “-10 °C to +85 °C” to “-55 °C to +125 °C”). Updated <a href="#">Electrical Characteristics</a> (Updated <a href="#">DC Electrical Characteristics</a> (Updated the maximum values of I <sub>DD</sub> and I <sub>SB1</sub> parameters)). Updated <a href="#">Thermal Resistance</a> (Included values for 165-ball FBGA package).
*B	2806011	11/12/09	Added <a href="#">Neutron Soft Error Immunity</a> . Updated <a href="#">Capacitance</a> (Changed maximum value of Input capacitance (C <sub>IN</sub> ) from 2 pF to 4 pF, changed maximum value of Output capacitance (C <sub>O</sub> ) from 3 pF to 4 pF). Updated <a href="#">Ordering Information</a> (By including parts that are available) and added disclaimer at the top of Ordering Information table. Updated <a href="#">Package Diagram</a> .
*C	3022441	09/03/2010	Changed status from Preliminary to Final. Updated <a href="#">Ordering Information</a> (Updated part numbers) and added <a href="#">Ordering Code Definitions</a> . Added <a href="#">Acronyms and Units of Measure</a> . Updated <a href="#">Sales, Solutions and Legal Information</a> .
*D	3243572	04/28/2011	Updated <a href="#">Ordering Information</a> (Updated part numbers). Updated to new template.
*E	3275033	06/06/2011	No technical updates.
*F	3430142	11/04/2011	Updated <a href="#">Ordering Information</a> (Updated part numbers). Updated <a href="#">Package Diagram</a> .
*G	3565554	03/29/2012	Updated <a href="#">Features</a> (Removed CY7C1616KV18, CY7C1627KV18 related information). Updated <a href="#">Configuration</a> (Removed CY7C1616KV18, CY7C1627KV18 related information). Updated <a href="#">Functional Description</a> (Removed CY7C1616KV18, CY7C1627KV18 related information). Updated <a href="#">Selection Guide</a> (Removed 250 MHz, 200 MHz, and 167 MHz frequencies related information). Removed Logic Block Diagram – CY7C1616KV18. Removed Logic Block Diagram – CY7C1627KV18. Updated <a href="#">Pin Configurations</a> (Removed CY7C1616KV18, CY7C1627KV18 related information). Updated <a href="#">Pin Definitions</a> (Removed CY7C1616KV18, CY7C1627KV18 related information). Updated <a href="#">Functional Overview</a> (Removed CY7C1616KV18, CY7C1627KV18 related information). Updated <a href="#">Write Cycle Descriptions</a> (Removed CY7C1616KV18 related information). Removed Write Cycle Descriptions (corresponding to CY7C1627KV18). Updated <a href="#">Identification Register Definitions</a> (Removed CY7C1616KV18, CY7C1627KV18 related information). Updated <a href="#">Electrical Characteristics</a> (Updated <a href="#">DC Electrical Characteristics</a> (Removed CY7C1616KV18, CY7C1627KV18 related information, removed 250 MHz, 200 MHz, and 167 MHz frequencies related information, removed 300 MHz frequency related information for only CY7C1620KV18)). Updated <a href="#">Switching Characteristics</a> (Removed 250 MHz, 200 MHz, and 167 MHz frequencies related information). Updated <a href="#">Ordering Information</a> (Updated part numbers).

**Document History Page** (continued)

Document Title: CY7C1618KV18/CY7C1620KV18, 144-Mbit DDR II SRAM Two-Word Burst Architecture			
Document Number: 001-44274			
Rev.	ECN No.	Submission Date	Description of Change
*H	3702845	08/06/2012	Updated <a href="#">Selection Guide</a> (Included 250 MHz frequency related information). Updated <a href="#">Electrical Characteristics</a> (Updated <a href="#">DC Electrical Characteristics</a> (Included 250 MHz frequency related information)). Updated <a href="#">Switching Characteristics</a> (Included 250 MHz frequency related information). Updated <a href="#">Ordering Information</a> (Updated part numbers).
*I	3800880	11/02/2012	No technical updates. Completing Sunset Review.
*J	4372963	05/07/2014	Updated <a href="#">Application Example</a> : Updated <a href="#">Figure 2</a> . Updated <a href="#">Thermal Resistance</a> : Updated values of $\Theta_{JA}$ parameter. Included $\Theta_{JB}$ parameter and its details. Updated to new template.
*K	4575228	11/20/2014	Updated <a href="#">Functional Description</a> : Added "For a complete list of related documentation, click <a href="#">here</a> ." at the end.
*L	5072740	01/05/2016	Updated <a href="#">Package Diagram</a> : spec 51-85195 – Changed revision from *C to *D. Updated to new template. Completing Sunset Review.
*M	5131023	02/09/2016	Updated <a href="#">Switching Waveforms</a> : Updated <a href="#">Read/Write/Deselect Sequence</a> : Updated <a href="#">Figure 6</a> .
*N	5980689	11/30/2017	Updated logo and copyright.
*O	6872794	04/30/2020	Updated <a href="#">Package Diagram</a> : spec 51-85195 – Changed revision from *D to *E.

## Sales, Solutions and Legal Information

### Worldwide Sales and Design Support

Cypress maintains a worldwide network of offices, solution centers, manufacturer's representatives, and distributors. To find the office closest to you, visit us at [Cypress Locations](#).

### Products

ARM <sup>®</sup> Cortex <sup>®</sup> Microcontrollers	<a href="http://cypress.com/arm">cypress.com/arm</a>
Automotive	<a href="http://cypress.com/automotive">cypress.com/automotive</a>
Clocks & Buffers	<a href="http://cypress.com/clocks">cypress.com/clocks</a>
Interface	<a href="http://cypress.com/interface">cypress.com/interface</a>
Internet of Things	<a href="http://cypress.com/iot">cypress.com/iot</a>
Memory	<a href="http://cypress.com/memory">cypress.com/memory</a>
Microcontrollers	<a href="http://cypress.com/mcu">cypress.com/mcu</a>
PSoC	<a href="http://cypress.com/psoc">cypress.com/psoc</a>
Power Management ICs	<a href="http://cypress.com/pmic">cypress.com/pmic</a>
Touch Sensing	<a href="http://cypress.com/touch">cypress.com/touch</a>
USB Controllers	<a href="http://cypress.com/usb">cypress.com/usb</a>
Wireless Connectivity	<a href="http://cypress.com/wireless">cypress.com/wireless</a>

### PSoC<sup>®</sup> Solutions

[PSoC 1](#) | [PSoC 3](#) | [PSoC 4](#) | [PSoC 5LP](#) | [PSoC 6 MCU](#)

### Cypress Developer Community

[Community](#) | [Code Examples](#) | [Projects](#) | [Video](#) | [Blogs](#) | [Training](#) | [Components](#)

### Technical Support

[cypress.com/support](http://cypress.com/support)

© Cypress Semiconductor Corporation, 2008-2020. This document is the property of Cypress Semiconductor Corporation and its subsidiaries ("Cypress"). This document, including any software or firmware included or referenced in this document ("Software"), is owned by Cypress under the intellectual property laws and treaties of the United States and other countries worldwide. Cypress reserves all rights under such laws and treaties and does not, except as specifically stated in this paragraph, grant any license under its patents, copyrights, trademarks, or other intellectual property rights. If the Software is not accompanied by a license agreement and you do not otherwise have a written agreement with Cypress governing the use of the Software, then Cypress hereby grants you a personal, non-exclusive, nontransferable license (without the right to sublicense) (1) under its copyright rights in the Software (a) for Software provided in source code form, to modify and reproduce the Software solely for use with Cypress hardware products, only internally within your organization, and (b) to distribute the Software in binary code form externally to end users (either directly or indirectly through resellers and distributors), solely for use on Cypress hardware product units, and (2) under those claims of Cypress's patents that are infringed by the Software (as provided by Cypress, unmodified) to make, use, distribute, and import the Software solely for use with Cypress hardware products. Any other use, reproduction, modification, translation, or compilation of the Software is prohibited.

TO THE EXTENT PERMITTED BY APPLICABLE LAW, CYPRESS MAKES NO WARRANTY OF ANY KIND, EXPRESS OR IMPLIED, WITH REGARD TO THIS DOCUMENT OR ANY SOFTWARE OR ACCOMPANYING HARDWARE, INCLUDING, BUT NOT LIMITED TO, THE IMPLIED WARRANTIES OF MERCHANTABILITY AND FITNESS FOR A PARTICULAR PURPOSE. No computing device can be absolutely secure. Therefore, despite security measures implemented in Cypress hardware or software products, Cypress shall have no liability arising out of any security breach, such as unauthorized access to or use of a Cypress product. CYPRESS DOES NOT REPRESENT, WARRANT, OR GUARANTEE THAT CYPRESS PRODUCTS, OR SYSTEMS CREATED USING CYPRESS PRODUCTS, WILL BE FREE FROM CORRUPTION, ATTACK, VIRUSES, INTERFERENCE, HACKING, DATA LOSS OR THEFT, OR OTHER SECURITY INTRUSION (collectively, "Security Breach"). Cypress disclaims any liability relating to any Security Breach, and you shall and hereby do release Cypress from any claim, damage, or other liability arising from any Security Breach. In addition, the products described in these materials may contain design defects or errors known as errata which may cause the product to deviate from published specifications. To the extent permitted by applicable law, Cypress reserves the right to make changes to this document without further notice. Cypress does not assume any liability arising out of the application or use of any product or circuit described in this document. Any information provided in this document, including any sample design information or programming code, is provided only for reference purposes. It is the responsibility of the user of this document to properly design, program, and test the functionality and safety of any application made of this information and any resulting product. "High-Risk Device" means any device or system whose failure could cause personal injury, death, or property damage. Examples of High-Risk Devices are weapons, nuclear installations, surgical implants, and other medical devices. "Critical Component" means any component of a High-Risk Device whose failure to perform can be reasonably expected to cause, directly or indirectly, the failure of the High-Risk Device, or to affect its safety or effectiveness. Cypress is not liable, in whole or in part, and you shall and hereby do release Cypress from any claim, damage, or other liability arising from any use of a Cypress product as a Critical Component in a High-Risk Device. You shall indemnify and hold Cypress, its directors, officers, employees, agents, affiliates, distributors, and assigns harmless from and against all claims, costs, damages, and expenses, arising out of any claim, including claims for product liability, personal injury or death, or property damage arising from any use of a Cypress product as a Critical Component in a High-Risk Device. Cypress products are not intended or authorized for use as a Critical Component in any High-Risk Device except to the limited extent that (i) Cypress's published data sheet for the product explicitly states Cypress has qualified the product for use in a specific High-Risk Device, or (ii) Cypress has given you advance written authorization to use the product as a Critical Component in the specific High-Risk Device and you have signed a separate indemnification agreement.

Cypress, the Cypress logo, Spansion, the Spansion logo, and combinations thereof, WICED, PSoC, CapSense, EZ-USB, F-RAM, and Traveo are trademarks or registered trademarks of Cypress in the United States and other countries. For a more complete list of Cypress trademarks, visit [cypress.com](http://cypress.com). Other names and brands may be claimed as property of their respective owners.

## Looking for pricing, stock, or lifecycle information?

Click below to explore more details on WIN SOURCE:

 [View CY7C1620KV18-333BZXI on WIN SOURCE](#)

 [Infineon Technologies](#) Information

## Optimize Your Supply Chain with WIN SOURCE Solutions

-  Global Sourcing Solution
-  Obsolete Management
-  Cost Control Management
-  Shortage Management
-  Alternative Solution
-  Excess Inventory Management