



THE DATASHEET OF
AOZ8231ADI-12



General Description

The AOZ8231A is a one-line bi-directional transient voltage suppressor diode designed to protect voltage sensitive electronics from high transient conditions and ESD.

This device incorporates one TVS diode in an ultra-small DFN 1006 package. It may be used to meet the ESD immunity requirements of EC 61000-4-2, Level 4 (± 15 kV air, ± 8 kV contact discharge).

The AOZ8231A comes in a RoHS compliant, Halogen-Free DFN 1.0 mm x 0.6 mm package and is rated over a -40 °C to $+85$ °C ambient temperature range.

The ultra-small 1.0 mm x 0.6 mm x 0.5 mm DFN package makes it ideal for applications where PCB space is a premium. The small size and high ESD protection makes it ideal for protecting voltage sensitive electronics from high transient conditions and ESD.

Applications

- Portable handheld devices
- Keypads, data lines, buttons
- Notebook computers
- Digital Cameras
- Portable GPS
- MP3 players

Features

- ESD protection for high-speed data lines
 - AOZ8231ADI-02:
 - Exceeds: IEC 61000-4-2 (ESD) ± 30 kV (air), ± 30 kV (contact)
 - Human Body Model (HBM) ± 30 kV
 - IEC 61000-4-5 (Lightning) 6 A (8/20 μ S)
 - IEC 61000-4-4 (EFT) 40 A
 - AOZ8231ADI-03:
 - Exceeds: IEC 61000-4-2 (ESD) ± 30 kV (air), ± 30 kV (contact)
 - Human Body Model (HBM) ± 30 kV
 - IEC 61000-4-5 (Lightning) 6 A (8/20 μ S)
 - IEC 61000-4-4 (EFT) 40 A
 - AOZ8231ADI-05:
 - Exceeds: IEC 61000-4-2 (ESD) ± 30 kV (air), ± 30 kV (contact)
 - Human Body Model (HBM) ± 30 kV
 - IEC 61000-4-5 (Lightning) 5 A (8/20 μ S)
 - IEC 61000-4-4 (EFT) 40 A
 - AOZ8231ADI-08:
 - Exceeds: IEC 61000-4-2 (ESD) ± 30 kV (air), ± 30 kV (contact)
 - Human Body Model (HBM) ± 30 kV
 - IEC 61000-4-5 (Lightning) 5 A (8/20 μ S)
 - IEC 61000-4-4 (EFT) 40 A
 - AOZ8231ADI-12:
 - Exceeds: IEC 61000-4-2 (ESD) ± 30 kV (air), ± 30 kV (contact)
 - Human Body Model (HBM) ± 30 kV
 - IEC 61000-4-5 (Lightning) 4 A (8/20 μ S)
 - IEC 61000-4-4 (EFT) 40 A
 - AOZ8231ADI-24:
 - Exceeds: IEC 61000-4-2 (ESD) ± 18 kV (air), ± 15 kV (contact)
 - Human Body Model (HBM) ± 15 kV
 - IEC 61000-4-5 (Lightning) 2.5 A (8/20 μ S)
 - IEC 61000-4-4 (EFT) 40 A
- Small package saves board space
- Low insertion loss
- Low clamping voltage
- Low operating voltage
- Pb-free device



Typical Application

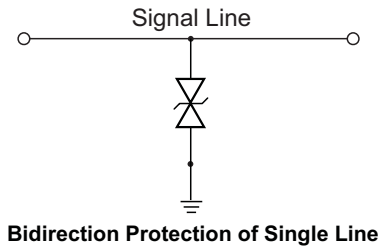

Pin Configuration



Ordering Information

Part Number	Ambient Temperature Range	Package	Environmental
AOZ8231ADI-02	-40 °C to +85 °C	DFN 1.0 x 0.6	Green Product
AOZ8231ADI-03			
AOZ8231ADI-05			
AOZ8231ADI-08			
AOZ8231ADI-12			
AOZ8231ADI-24			



AOS Green Products use reduced levels of Halogens, and are also RoHS compliant. Please visit www.aosmd.com/media/AOSGreenPolicy.pdf for additional information.

Absolute Maximum Ratings

Exceeding the Absolute Maximum ratings may damage the device.

Parameter	Rating for AOZ8231ADI					
	-02	-03	-05	-08	-12	-24
VP – VN	2.5 V	3.3 V	5 V	8 V	12 V	24 V
Peak Pulse Current, $t_p = 8/20 \mu s$	6 A	6 A	5 A	5 A	4 A	2.5 A
Storage Temperature (T_S)	-65 °C to +150 °C					
ESD Rating per IEC61000-4-2, Contact ⁽¹⁾	± 30 kV	± 30 kV	± 30 kV	± 30 kV	± 30 kV	± 15 kV
ESD Rating per IEC61000-4-2, Air ⁽¹⁾	± 30 kV	± 30 kV	± 30 kV	± 30 kV	± 30 kV	± 18 kV
ESD Rating per Human Body Model ⁽²⁾	± 30 kV	± 30 kV	± 30 kV	± 30 kV	± 30 kV	± 15 kV

Notes:

- IEC 61000-4-2 discharge with $C_{Discharge} = 150 \text{ pF}$, $R_{Discharge} = 330 \Omega$.
- Human Body Discharge per MIL-STD-883, Method 3015 $C_{Discharge} = 100 \text{ pF}$, $R_{Discharge} = 1.5 \text{ k}\Omega$.

Maximum Operating Ratings

Parameter	Rating
Junction Temperature (T_J)	-40 °C to +125 °C

Electrical Characteristics

$T_A = 25\text{ }^\circ\text{C}$ unless otherwise specified.

Symbol	Parameter	Diagram
I_{PP}	Reverse Peak Pulse Current, ($t_{\text{period}} = 100\text{ ns}$, $t_r = 1\text{ ns}$)	
V_{CL}	Clamping Voltage @ I_{PP}	
V_{RWM}	Working Peak Reverse Voltage	
I_R	Maximum Reverse Leakage Current	
V_{BR}	Breakdown Voltage	
C_J	Capacitance @ $V_R = 0$ and $f = 1\text{ MHz}$	

Device	Device Marking	V_{RWM} (V) Max.	V_{BR} (V) Min. @ 1mA	I_R (μA) Max.	V_{CL} Max. ⁽³⁾			C_J (pF) ⁽³⁾		
					$I_{PP} = 1\text{ A}$	$I_{PP} = 5\text{ A}$	$I_{PP} = 12\text{ A}$	Min.	Typ.	Max.
AOZ8231ADI-02	P	2.5	3.0	0.1	6.5	9.0	12.5	4.4	5.5	7.0
AOZ8231ADI-03	D	3.3	3.7	0.1	7.5	10.0	13.5	4.4	5.5	7.0
AOZ8231ADI-05	E	5.0	5.5	0.1	10.5	13.5	15.5	10.4	13.0	14.0
AOZ8231ADI-08	Y	8.0	9.5	0.1	15.0	18.0	22.5	19.0	23.0	27.0
AOZ8231ADI-12	F	12.0	13.0	0.1	20.0	23.0	26.0	10.4	13.0	14.0
AOZ8231ADI-24	R	24.0	27.0	0.1	35.0	38.0	39.0	9.6	12.0	15.0

Note:

3. Guaranteed by design and characterization.

Typical Performance Characteristics

Clamping Voltage vs. Peak Pulse Current

($t_{\text{period}} = 100 \text{ ns}$, $t_r = 1 \text{ ns}$)

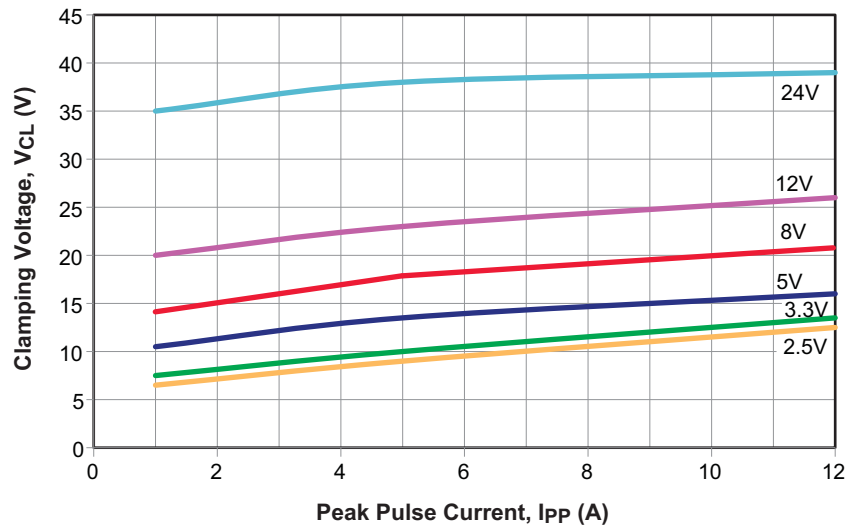

Typical Variation of C_{IN} vs. V_R

($f = 1 \text{ MHz}$, $T = 25 \text{ }^\circ\text{C}$)

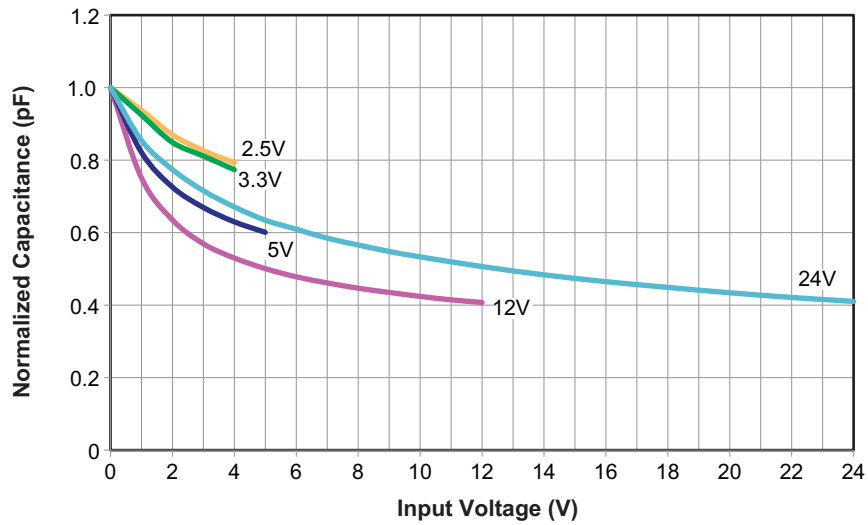

Package Dimensions, DFN 1.0 x 0.6

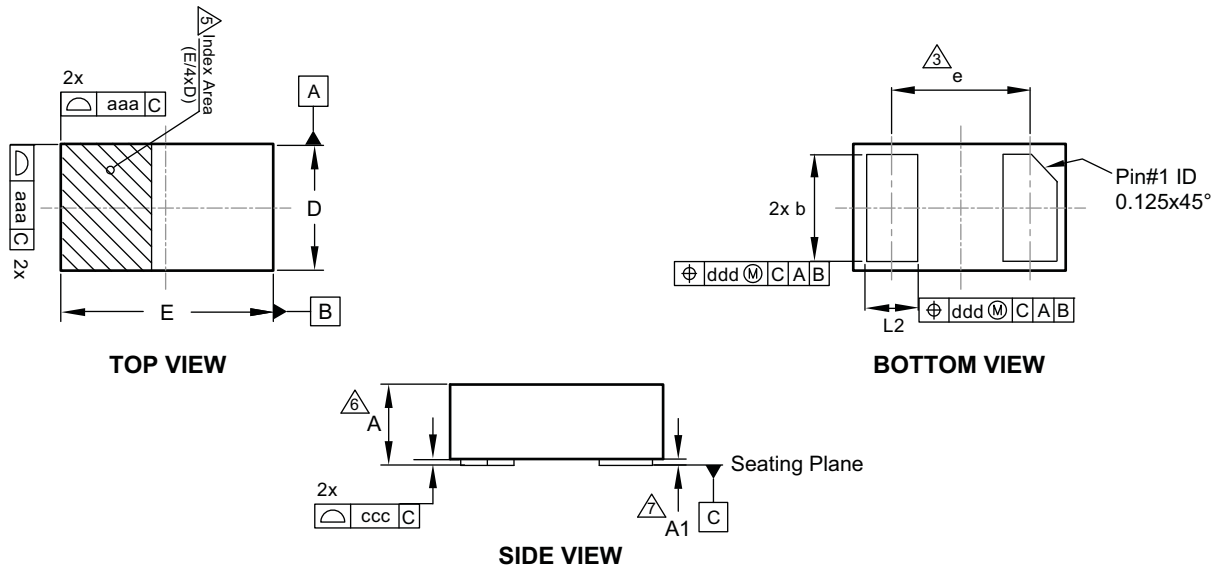

RECOMMENDED LAND PATTERN

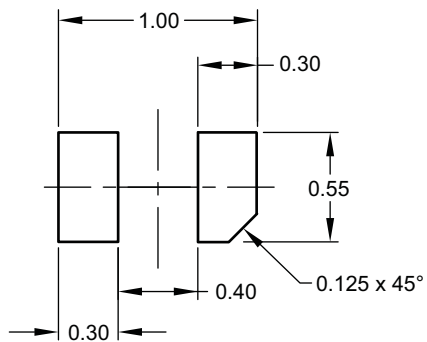

UNIT: mm

Dimensions in millimeters

Symbols	Min.	Nom.	Max.
A	0.47	0.51	0.55
A1	0.00	0.02	0.05
b	0.45	0.50	0.55
D	0.60 BSC		
E	1.00 BSC		
e	0.65 BSC		
L	0.20	0.25	0.30
aaa	0.05		
ccc	0.03		
ddd	0.10		

Dimensions in inches

Symbols	Min.	Nom.	Max.
A	0.019	0.020	0.022
A1	0.000	0.001	0.002
b	0.018	0.020	0.022
D	0.024		
E	0.039		
e	0.026		
L	0.008	0.010	0.012
aaa	0.002		
ccc	0.001		
ddd	0.004		

Notes:

1. Dimensions and tolerancing conform to ASME Y14.5-2009.
 2. All dimensions are in millimeters.
 3. "e" represents the terminal grid pitch.
 4. N is the total number of terminals.
- △ A visual index feature must be located within the hatched area. Typical index feature (chamfer) must be located on the edge of the Pin#1 feature.
 - △ This dimension includes stand-off height "A1" and packaged body thickness, but does not include attached feature e.g. external heatsink or chip capacitors, an internal heatslug is not considered as attached feature.
 - △ Dimension "A1" is primarily terminal plating, and does not include small metal protrusions.

Tape and Reel Dimensions, DFN 1.0 x 0.6

Carrier Tape

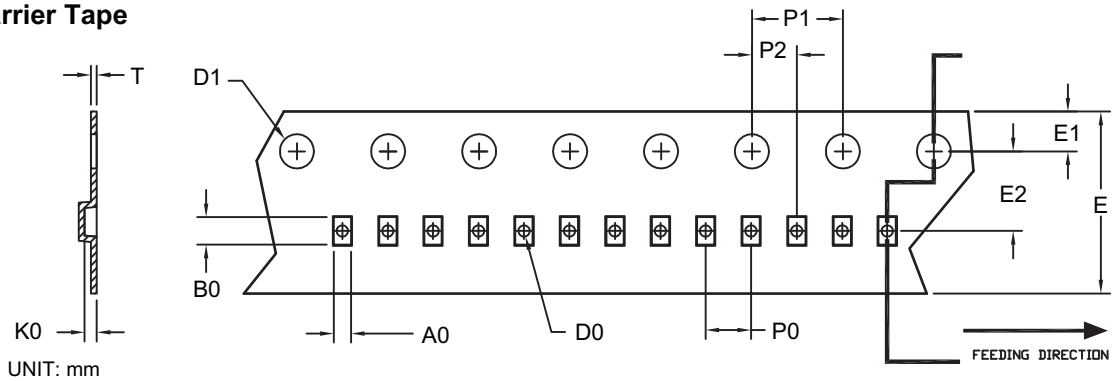

UNIT: mm

Option	Package	A0	B0	K0	D0	D1	E	E1	E2	P0	P1	P2	T
A	DFN 1.0x0.6/ DFN 1.0x0.6A (8 mm)	0.69 ±0.05	1.19 ±0.05	0.66 ±0.05	0.40 ±0.05	1.50 ±0.10	8.00 +0.3/-0.1	1.75 ±0.10	3.50 ±0.05	2.00 ±0.05	4.00 ±0.10	2.00 ±0.05	0.23 ±0.02
B	DFN 1.0x0.6/ DFN 1.0x0.6A (8 mm)	0.65 ±0.04	1.05 ±0.04	0.61 ±0.04	0.40 ±0.05	1.50 ±0.10	8.00 +0.3/-0.1	1.75 ±0.10	3.50 ±0.05	2.00 ±0.10	4.00 ±0.10	2.00 ±0.05	0.20 ±0.05

Reel

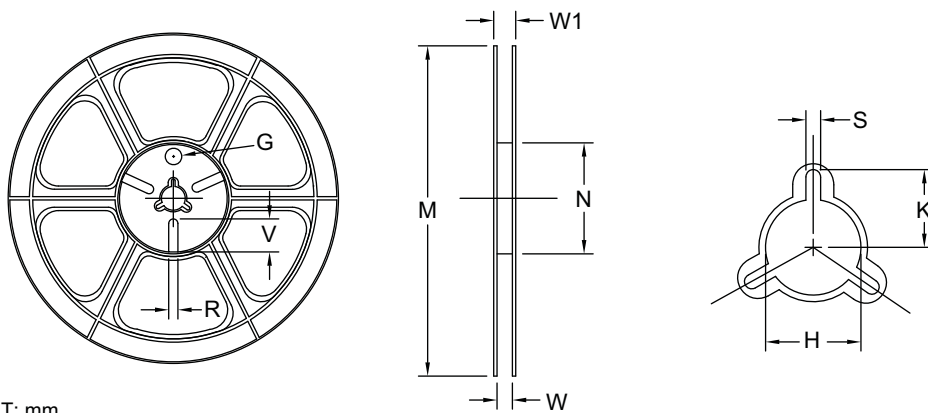

UNIT: mm

Tape Size	Reel Size	M	N	W	W1	H	K	S	G	R	V
8mm	ø178	ø178 ±0.5	ø55 ±1	8.4 +1.5/-0	Max. 14.4	ø13.0 ±0.5	Max. 10.1	2.0 ±0.5	N/A	N/A	N/A

Leader / Trailer & Orientation

TVS
Unit Per Reel:
10000pcs

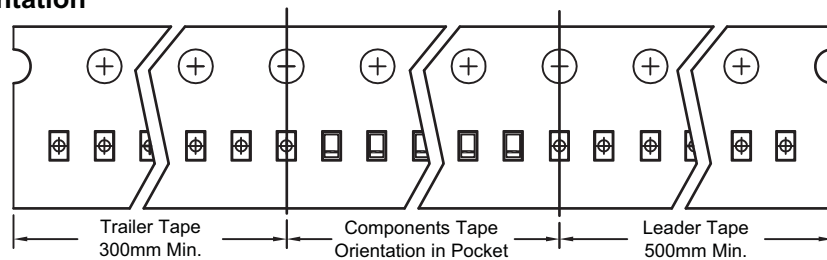

Part Marking

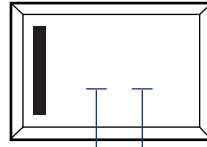

Product Number Code Date Code

AOZ8231ADI_02 = **P**

AOZ8231ADI_03 = **D**

AOZ8231ADI_05 = **E**

AOZ8231ADI_08 = **Y**

AOZ8231ADI_12 = **F**

AOZ8231ADI_24 = **R**

LEGAL DISCLAIMER

Alpha and Omega Semiconductor makes no representations or warranties with respect to the accuracy or completeness of the information provided herein and takes no liabilities for the consequences of use of such information or any product described herein. Alpha and Omega Semiconductor reserves the right to make changes to such information at any time without further notice. This document does not constitute the grant of any intellectual property rights or representation of non-infringement of any third party's intellectual property rights.

LIFE SUPPORT POLICY

ALPHA AND OMEGA SEMICONDUCTOR PRODUCTS ARE NOT AUTHORIZED FOR USE AS CRITICAL COMPONENTS IN LIFE SUPPORT DEVICES OR SYSTEMS.

As used herein:

1. Life support devices or systems are devices or systems which, (a) are intended for surgical implant into the body or (b) support or sustain life, and (c) whose failure to perform when properly used in accordance with instructions for use provided in the labeling, can be reasonably expected to result in a significant injury of the user.

2. A critical component in any component of a life support, device, or system whose failure to perform can be reasonably expected to cause the failure of the life support device or system, or to affect its safety or effectiveness.

Looking for pricing, stock, or lifecycle information?

Click below to explore more details on WIN SOURCE:

- ⊖ [View AOZ8231ADI-12 on WIN SOURCE](#)
- ⊖ [Alpha & Omega Semiconductor Inc. Information](#)

Optimize Your Supply Chain with WIN SOURCE Solutions

- ✓ Global Sourcing Solution
- ✓ Obsolete Management
- ✓ Cost Control Management
- ✓ Shortage Management
- ✓ Alternative Solution
- ✓ Excess Inventory Management