



**THE DATASHEET OF
MSP430F5438AIZQWT**



MSP430F543xA, MSP430F541xA Mixed-Signal Microcontrollers

1 Features

- Low supply voltage range: 3.6 V down to 1.8 V
- Ultra-low power consumption
 - Active mode (AM): all system clocks active
230 μ A/MHz at 8 MHz, 3.0 V, flash program execution (typical)
110 μ A/MHz at 8 MHz, 3.0 V, RAM program execution (typical)
 - Standby mode (LPM3): real-time clock (RTC) with crystal, watchdog, and supply supervisor operational, full RAM retention, fast wakeup:
1.7 μ A at 2.2 V, 2.1 μ A at 3.0 V (typical)
low-power oscillator (VLO), general-purpose counter, watchdog, and supply supervisor operational, full RAM retention, fast wakeup:
1.2 μ A at 3.0 V (typical)
 - Off mode (LPM4): full RAM retention, supply supervisor operational, fast wakeup:
1.2 μ A at 3.0 V (typical)
 - Shutdown mode (LPM4.5): 0.1 μ A at 3.0 V (typical)
- Wake up from standby mode in 3.5 μ s (typical)
- 16-bit RISC architecture
 - Extended memory
 - Up to 25-MHz system clock
- Flexible power-management system
 - Fully integrated LDO with programmable regulated core supply voltage
 - Supply voltage supervision, monitoring, and brownout
- Unified clock system
 - FLL control loop for frequency stabilization
 - Low-power low-frequency internal clock source (VLO)
 - Low-frequency trimmed internal reference source (REFO)
- 32-kHz crystals
- High-frequency crystals up to 32 MHz
- 16-bit timer TA0, Timer_A with five capture/compare registers
- 16-bit timer TA1, Timer_A with three capture/compare registers
- 16-bit timer TB0, Timer_B with seven capture/compare shadow registers
- Up to four universal serial communication interfaces (USCIs)
 - USCI_A0, USCI_A1, USCI_A2, and USCI_A3 each support:
 - Enhanced UART supports automatic baud-rate detection
 - IrDA encoder and decoder
 - Synchronous SPI
 - USCI_B0, USCI_B1, USCI_B2, and USCI_B3 each support:
 - I²C
 - Synchronous SPI
- 12-bit analog-to-digital converter (ADC)
 - Internal reference
 - Sample-and-hold
 - Autoscan feature
 - 14 external channels, 2 internal channels
- Hardware multiplier supports 32-bit operations
- Serial onboard programming, no external programming voltage needed
- 3-channel internal DMA
- Basic timer with RTC feature
- [Device Comparison](#) summarizes the available family members

2 Applications

- Analog and Digital Sensor Systems
- Digital Motor Controls
- Remote Controls
- Thermostats
- Digital Timers
- Hand-Held Meters

3 Description

The TI MSP family of ultra-low-power microcontrollers consists of several devices featuring different sets of peripherals targeted for various applications. The architecture, combined with extensive low-power modes, is optimized to achieve extended battery life in portable measurement applications. The device features a powerful 16-bit RISC CPU, 16-bit registers, and constant generators that contribute to maximum code efficiency. The digitally controlled oscillator (DCO) allows the device to wake up from low-power modes to active mode in 3.5 μ s (typical).



The MSP430F543xA and MSP430F541xA series are microcontroller configurations with three 16-bit timers, a high-performance 12-bit ADC, up to four USCIs, a hardware multiplier, DMA, an RTC module with alarm capabilities, and up to 87 I/O pins.

For complete module descriptions, see the [MSP430F5xx and MSP430F6xx Family User's Guide](#).

Device Information

PART NUMBER ⁽¹⁾	PACKAGE	BODY SIZE ⁽²⁾
MSP430F5438AIPZ	LQFP (100)	14 mm × 14 mm
MSP430F5437AIPN	LQFP (80)	12 mm × 12 mm
MSP430F5438AIZCA	nFBGA (113)	7 mm × 7 mm
MSP430F5438AIZQW ⁽³⁾	MicroStar Junior™ BGA (113)	7 mm × 7 mm

- (1) For the most current part, package, and ordering information, see the *Package Option Addendum* in [Section 11](#), or see the TI website at www.ti.com.
- (2) The sizes shown here are approximations. For the package dimensions with tolerances, see the *Mechanical Data* in [Section 11](#).
- (3) All orderable part numbers in the ZQW (MicroStar Junior BGA) package have been changed to a status of Last Time Buy. Visit the [Product life cycle](#) page for details on this status.

Table of Contents

1 Features	1	8.28 Timer_A.....	31
2 Applications	1	8.29 Timer_B.....	31
3 Description	1	8.30 USCI (UART Mode) Clock Frequency.....	31
4 Functional Block Diagrams	3	8.31 USCI (UART Mode).....	31
5 Revision History	5	8.32 USCI (SPI Master Mode) Clock Frequency.....	32
6 Device Comparison	6	8.33 USCI (SPI Master Mode).....	32
6.1 Related Products.....	6	8.34 USCI (SPI Slave Mode).....	34
7 Terminal Configuration and Functions	7	8.35 USCI (I ² C Mode).....	36
7.1 Pin Diagrams.....	7	8.36 12-Bit ADC, Power Supply and Input Range Conditions.....	37
7.2 Signal Descriptions.....	10	8.37 12-Bit ADC, Timing Parameters.....	37
8 Specifications	15	8.38 12-Bit ADC, Linearity Parameters Using an External Reference Voltage or AVCC as Reference Voltage.....	38
8.1 Absolute Maximum Ratings.....	15	8.39 12-Bit ADC, Linearity Parameters Using the Internal Reference Voltage.....	38
8.2 ESD Ratings.....	15	8.40 12-Bit ADC, Temperature Sensor and Built-In V _{MID}	39
8.3 Recommended Operating Conditions.....	15	8.41 REF, External Reference.....	40
8.4 Active Mode Supply Current Into V _{CC} Excluding External Current.....	16	8.42 REF, Built-In Reference.....	41
8.5 Low-Power Mode Supply Currents (Into V _{CC}) Excluding External Current.....	17	8.43 Flash Memory.....	42
8.6 Thermal Resistance Characteristics.....	18	8.44 JTAG and Spy-Bi-Wire Interface.....	42
8.7 Schmitt-Trigger Inputs – General-Purpose I/O.....	18	9 Detailed Description	43
8.8 Inputs – Ports P1 and P2.....	18	9.1 CPU.....	43
8.9 Leakage Current – General-Purpose I/O.....	19	9.2 Operating Modes.....	44
8.10 Outputs – General-Purpose I/O (Full Drive Strength).....	20	9.3 Interrupt Vector Addresses.....	45
8.11 Outputs – General-Purpose I/O (Reduced Drive Strength).....	20	9.4 Memory Organization.....	46
8.12 Output Frequency – General-Purpose I/O.....	20	9.5 Bootloader (BSL).....	46
8.13 Typical Characteristics – Outputs, Reduced Drive Strength (PxDS.y = 0).....	21	9.6 JTAG Operation.....	47
8.14 Typical Characteristics – Outputs, Full Drive Strength (PxDS.y = 1).....	22	9.7 Flash Memory.....	48
8.15 Crystal Oscillator, XT1, Low-Frequency Mode.....	23	9.8 RAM.....	48
8.16 Crystal Oscillator, XT1, High-Frequency Mode.....	24	9.9 Peripherals.....	48
8.17 Crystal Oscillator, XT2.....	25	9.10 Input/Output Diagrams.....	69
8.18 Internal Very-Low-Power Low-Frequency Oscillator (VLO).....	26	9.11 Device Descriptors.....	95
8.19 Internal Reference, Low-Frequency Oscillator (REFO).....	26	10 Device and Documentation Support	98
8.20 DCO Frequency.....	27	10.1 Getting Started.....	98
8.21 PMM, Brownout Reset (BOR).....	28	10.2 Device Nomenclature.....	98
8.22 PMM, Core Voltage.....	28	10.3 Tools and Software.....	100
8.23 PMM, SVS High Side.....	29	10.4 Documentation Support.....	102
8.24 PMM, SVM High Side.....	29	10.5 Support Resources.....	103
8.25 PMM, SVS Low Side.....	30	10.6 Trademarks.....	103
8.26 PMM, SVM Low Side.....	30	10.7 Electrostatic Discharge Caution.....	104
8.27 Wake-up Times From Low-Power Modes and Reset.....	30	10.8 Export Control Notice.....	104
		10.9 Glossary.....	104
		11 Mechanical, Packaging, and Orderable Information	105

5 Revision History

NOTE: Page numbers for previous revisions may differ from page numbers in the current version.

Changes from September 12, 2020 to May 10, 2021

Page

- Added nFBGA package (ZCA) thermal resistance characteristics..... **18**

6 Device Comparison

Table 6-1 summarizes the available family members.

Table 6-1. Device Characteristics

DEVICE ⁽¹⁾	FLASH (KB) ⁽²⁾	SRAM (KB)	Timer_A ⁽³⁾	Timer_B ⁽⁴⁾	USCI		ADC12_A (Ch)	I/O	PACKAGE
					CHANNEL A: UART, IrDA, SPI	CHANNEL B: SPI, I ² C			
MSP430F5438A	256	16	5, 3	7	4	4	14 ext, 2 int	87	100 PZ, 113 ZCA, 113 ZQW
MSP430F5437A	256	16	5, 3	7	2	2	14 ext, 2 int	67	80 PN
MSP430F5436A	192	16	5, 3	7	4	4	14 ext, 2 int	87	100 PZ, 113 ZCA, 113 ZQW
MSP430F5435A	192	16	5, 3	7	2	2	14 ext, 2 int	67	80 PN
MSP430F5419A	128	16	5, 3	7	4	4	14 ext, 2 int	87	100 PZ, 113 ZCA, 113 ZQW
MSP430F5418A	128	16	5, 3	7	2	2	14 ext, 2 int	67	80 PN

- (1) For the most current part, package, and ordering information, see the *Package Option Addendum* in [Section 11](#), or see the TI website at www.ti.com.
- (2) Package drawings, thermal data, and symbolization are available at www.ti.com/packaging.
- (3) Each number in the sequence represents an instantiation of Timer_A with its associated number of capture compare registers and PWM output generators available. For example, a number sequence of 3, 5 would represent two instantiations of Timer_A, the first instantiation having 3 and the second instantiation having 5 capture compare registers and PWM output generators, respectively.
- (4) Each number in the sequence represents an instantiation of Timer_B with its associated number of capture compare registers and PWM output generators available. For example, a number sequence of 3, 5 would represent two instantiations of Timer_B, the first instantiation having 3 and the second instantiation having 5 capture compare registers and PWM output generators.

6.1 Related Products

For information about other devices in this family of products or related products, see the following links.

[Products for TI Microcontrollers](#)

TI's low-power and high-performance MCUs, with wired and wireless connectivity options, are optimized for a broad range of applications.

[Products for MSP430 Ultra-Low-Power Microcontrollers](#)

One platform. One ecosystem. Endless possibilities. Enabling the connected world with innovations in ultra-low-power microcontrollers with advanced peripherals for precise sensing and measurement.

[Companion Products for MSP430F5438A](#)

Review products that are frequently purchased or used with this product.

[Reference Designs for MSP430F5438A](#)

Find reference designs that leverage the best in TI technology to solve your system-level challenges.

7 Terminal Configuration and Functions

7.1 Pin Diagrams

Figure 7-1 shows the pinout of the 100-pin PZ package for the MSP430F5438A, MSP430F5436A, and MSP430F5419A devices.

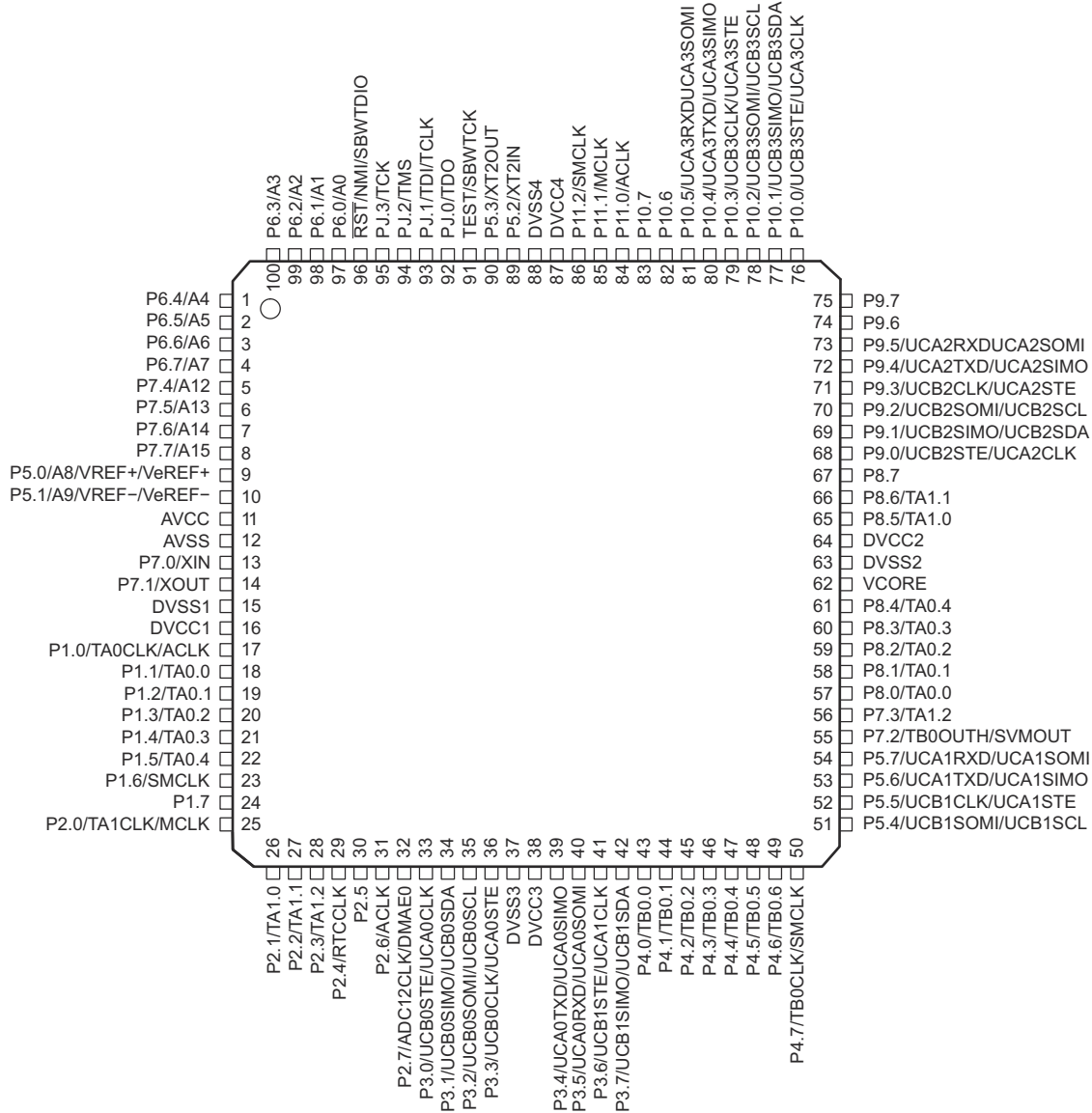

Figure 7-1. 100-Pin PZ Package (Top View) – MSP430F5438AIPZ, MSP430F5436AIPZ, MSP430F5419AIPZ

Figure 7-2 shows the pinout of the 80-pin PN package for the MSP430F5437A, MSP430F5435A, and MSP430F5418A devices.

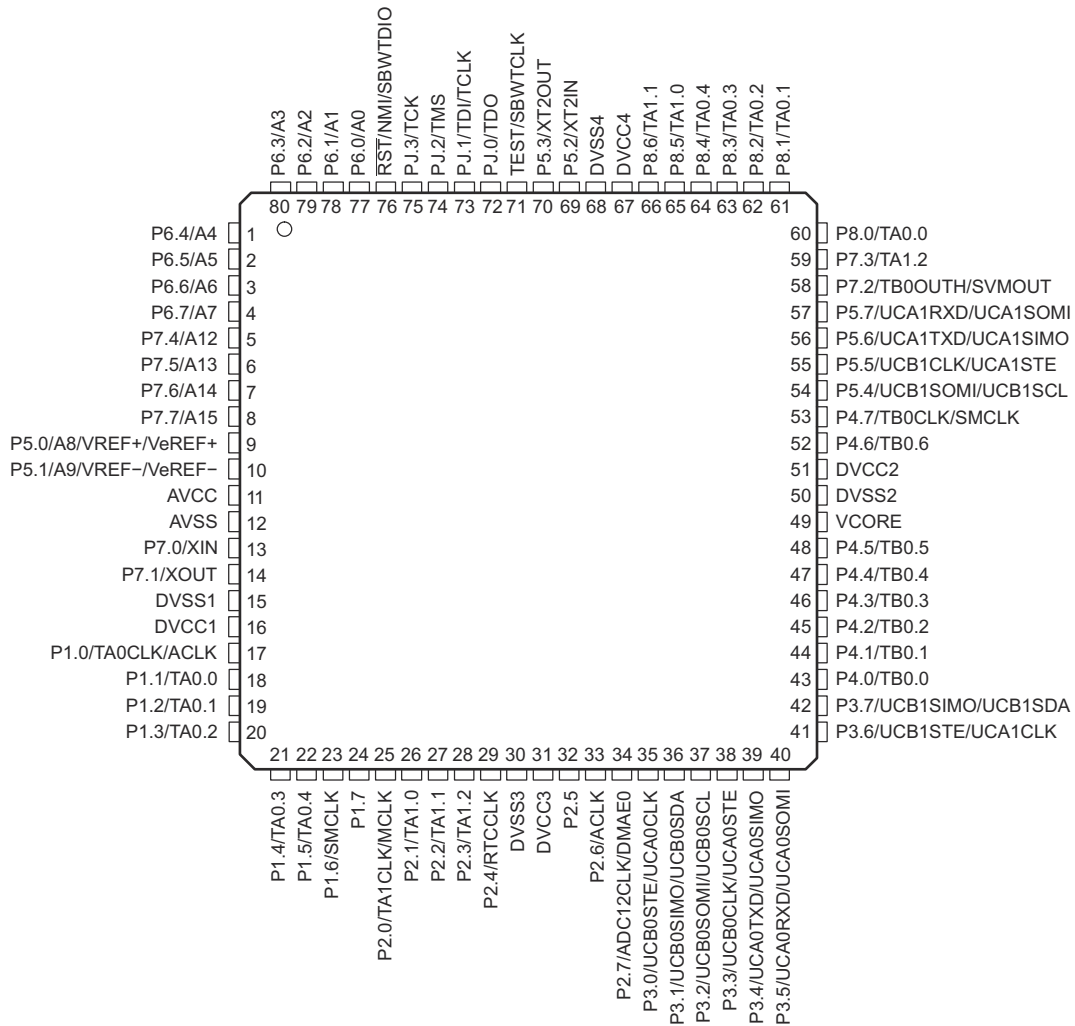

Figure 7-2. 80-Pin PN Package (Top View) – MSP430F5437AIPN, MSP430F5435AIPN, MSP430F5418AIPN

Figure 7-3 shows the pinout of the 113-pin ZCA or ZQW package for the MSP430F5438A, MSP430F5436A, and MSP430F5419A devices.

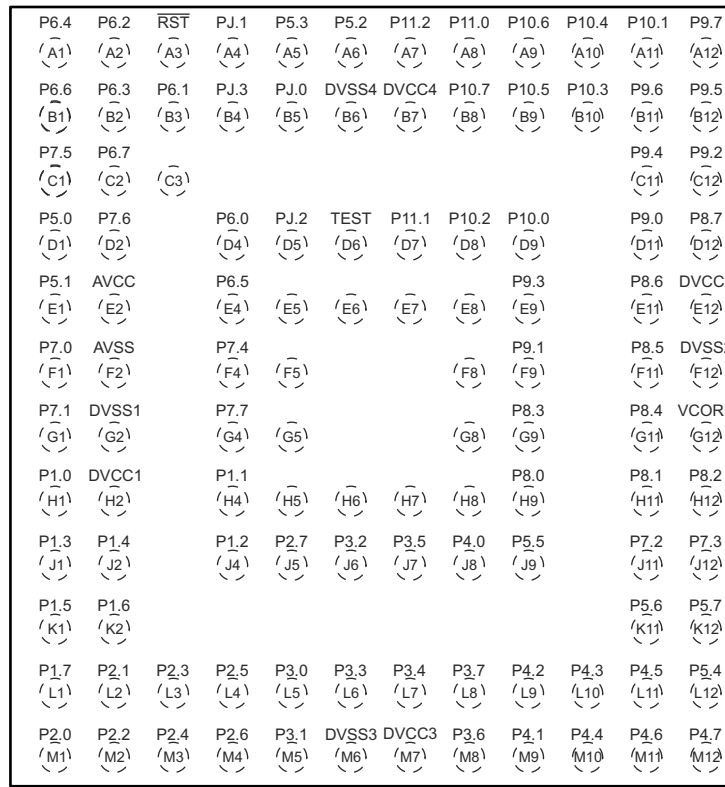

Figure 7-3. 113-Pin ZCA or ZQW Package (Top View) – MSP430F5438AIZCA, MSP430F5436AIZCA, MSP430F5419AIZCA, MSP430F5438AIZQW, MSP430F5436AIZQW, MSP430F5419AIZQW

7.2 Signal Descriptions

Section 7.2 describes the signals for all device variants and package options.

Table 7-1. Signal Descriptions

TERMINAL				I/O ⁽¹⁾	DESCRIPTION
NAME	NO.				
	PZ	PN	ZCA, ZQW		
P6.4/A4	1	1	A1	I/O	General-purpose digital I/O Analog input A4 for the ADC
P6.5/A5	2	2	E4	I/O	General-purpose digital I/O Analog input A5 for the ADC
P6.6/A6	3	3	B1	I/O	General-purpose digital I/O Analog input A6 for the ADC
P6.7/A7	4	4	C2	I/O	General-purpose digital I/O Analog input A7 for the ADC
P7.4/A12	5	5	F4	I/O	General-purpose digital I/O Analog input A12 for the ADC
P7.5/A13	6	6	C1	I/O	General-purpose digital I/O Analog input A13 for the ADC
P7.6/A14	7	7	D2	I/O	General-purpose digital I/O Analog input A14 for the ADC
P7.7/A15	8	8	G4	I/O	General-purpose digital I/O Analog input A15 for the ADC
P5.0/A8/VREF+/VeREF+	9	9	D1	I/O	General-purpose digital I/O Analog input A8 for the ADC Output of reference voltage to the ADC Input for an external reference voltage to the ADC
P5.1/A9/VREF-/VeREF-	10	10	E1	I/O	General-purpose digital I/O Analog input A9 for the ADC Negative terminal for the ADC reference voltage for both sources, the internal reference voltage, or an external applied reference voltage
AVCC	11	11	E2		Analog power supply
AVSS	12	12	F2		Analog ground supply
P7.0/XIN	13	13	F1	I/O	General-purpose digital I/O Input terminal for crystal oscillator XT1
P7.1/XOUT	14	14	G1	I/O	General-purpose digital I/O Output terminal of crystal oscillator XT1
DVSS1	15	15	G2		Digital ground supply
DVCC1	16	16	H2		Digital power supply
P1.0/TA0CLK/ACLK	17	17	H1	I/O	General-purpose digital I/O with port interrupt TA0 clock signal TACLK input ACLK output (divided by 1, 2, 4, 8, 16, or 32)
P1.1/TA0.0	18	18	H4	I/O	General-purpose digital I/O with port interrupt TA0 CCR0 capture: CCI0A input, compare: Out0 output BSL transmit output
P1.2/TA0.1	19	19	J4	I/O	General-purpose digital I/O with port interrupt TA0 CCR1 capture: CCI1A input, compare: Out1 output BSL receive input
P1.3/TA0.2	20	20	J1	I/O	General-purpose digital I/O with port interrupt TA0 CCR2 capture: CCI2A input, compare: Out2 output
P1.4/TA0.3	21	21	J2	I/O	General-purpose digital I/O with port interrupt TA0 CCR3 capture: CCI3A input compare: Out3 output
P1.5/TA0.4	22	22	K1	I/O	General-purpose digital I/O with port interrupt TA0 CCR4 capture: CCI4A input, compare: Out4 output

Table 7-1. Signal Descriptions (continued)

TERMINAL				I/O ⁽¹⁾	DESCRIPTION
NAME	NO.				
	PZ	PN	ZCA, ZQW		
P1.6/SMCLK	23	23	K2	I/O	General-purpose digital I/O with port interrupt SMCLK output
P1.7	24	24	L1	I/O	General-purpose digital I/O with port interrupt
P2.0/TA1CLK/MCLK	25	25	M1	I/O	General-purpose digital I/O with port interrupt TA1 clock signal TA1CLK input MCLK output
P2.1/TA1.0	26	26	L2	I/O	General-purpose digital I/O with port interrupt TA1 CCR0 capture: CCI0A input, compare: Out0 output
P2.2/TA1.1	27	27	M2	I/O	General-purpose digital I/O with port interrupt TA1 CCR1 capture: CCI1A input, compare: Out1 output
P2.3/TA1.2	28	28	L3	I/O	General-purpose digital I/O with port interrupt TA1 CCR2 capture: CCI2A input, compare: Out2 output
P2.4/RTCCLK	29	29	M3	I/O	General-purpose digital I/O with port interrupt RTCCLK output
P2.5	30	32	L4	I/O	General-purpose digital I/O with port interrupt
P2.6/ACLK	31	33	M4	I/O	General-purpose digital I/O with port interrupt ACLK output (divided by 1, 2, 4, 8, 16, or 32)
P2.7/ADC12CLK/DMAE0	32	34	J5	I/O	General-purpose digital I/O with port interrupt Conversion clock output for the ADC DMA external trigger input
P3.0/UCB0STE/UCA0CLK	33	35	L5	I/O	General-purpose digital I/O Slave transmit enable – USCI_B0 SPI mode Clock signal input – USCI_A0 SPI slave mode Clock signal output – USCI_A0 SPI master mode
P3.1/UCB0SIMO/UCB0SDA	34	36	M5	I/O	General-purpose digital I/O Slave in, master out – USCI_B0 SPI mode I ² C data – USCI_B0 I ² C mode
P3.2/UCB0SOMI/UCB0SCL	35	37	J6	I/O	General-purpose digital I/O Slave out, master in – USCI_B0 SPI mode I ² C clock – USCI_B0 I ² C mode
P3.3/UCB0CLK/UCA0STE	36	38	L6	I/O	General-purpose digital I/O Clock signal input – USCI_B0 SPI slave mode Clock signal output – USCI_B0 SPI master mode Slave transmit enable – USCI_A0 SPI mode
DVSS3	37	30	M6		Digital ground supply
DVCC3	38	31	M7		Digital power supply
P3.4/UCA0TXD/UCA0SIMO	39	39	L7	I/O	General-purpose digital I/O Transmit data – USCI_A0 UART mode Slave in, master out – USCI_A0 SPI mode
P3.5/UCA0RXD/UCA0SOMI	40	40	J7	I/O	General-purpose digital I/O Receive data – USCI_A0 UART mode Slave out, master in – USCI_A0 SPI mode
P3.6/UCB1STE/UCA1CLK	41	41	M8	I/O	General-purpose digital I/O Slave transmit enable – USCI_B1 SPI mode Clock signal input – USCI_A1 SPI slave mode Clock signal output – USCI_A1 SPI master mode
P3.7/UCB1SIMO/UCB1SDA	42	42	L8	I/O	General-purpose digital I/O Slave in, master out – USCI_B1 SPI mode I ² C data – USCI_B1 I ² C mode
P4.0/TB0.0	43	43	J8	I/O	General-purpose digital I/O TB0 capture CCR0: CCI0A/CCI0B input, compare: Out0 output

Table 7-1. Signal Descriptions (continued)

TERMINAL				I/O ⁽¹⁾	DESCRIPTION
NAME	NO.				
	PZ	PN	ZCA, ZQW		
P4.1/TB0.1	44	44	M9	I/O	General-purpose digital I/O TB0 capture CCR1: CCI1A/CCI1B input, compare: Out1 output
P4.2/TB0.2	45	45	L9	I/O	General-purpose digital I/O TB0 capture CCR2: CCI2A/CCI2B input, compare: Out2 output
P4.3/TB0.3	46	46	L10	I/O	General-purpose digital I/O TB0 capture CCR3: CCI3A/CCI3B input, compare: Out3 output
P4.4/TB0.4	47	47	M10	I/O	General-purpose digital I/O TB0 capture CCR4: CCI4A/CCI4B input, compare: Out4 output
P4.5/TB0.5	48	48	L11	I/O	General-purpose digital I/O TB0 capture CCR5: CCI5A/CCI5B input, compare: Out5 output
P4.6/TB0.6	49	52	M11	I/O	General-purpose digital I/O TB0 capture CCR6: CCI6A/CCI6B input, compare: Out6 output
P4.7/TB0CLK/SMCLK	50	53	M12	I/O	General-purpose digital I/O TB0 clock input SMCLK output
P5.4/UCB1SOMI/UCB1SCL	51	54	L12	I/O	General-purpose digital I/O Slave out, master in – USCI_B1 SPI mode I ² C clock – USCI_B1 I ² C mode
P5.5/UCB1CLK/UCA1STE	52	55	J9	I/O	General-purpose digital I/O Clock signal input – USCI_B1 SPI slave mode Clock signal output – USCI_B1 SPI master mode Slave transmit enable – USCI_A1 SPI mode
P5.6/UCA1TXD/UCA1SIMO	53	56	K11	I/O	General-purpose digital I/O Transmit data – USCI_A1 UART mode Slave in, master out – USCI_A1 SPI mode
P5.7/UCA1RXD/UCA1SOMI	54	57	K12	I/O	General-purpose digital I/O Receive data – USCI_A1 UART mode Slave out, master in – USCI_A1 SPI mode
P7.2/TB0OUTH/SVMOUT	55	58	J11	I/O	General-purpose digital I/O Switch all PWM outputs to high impedance – Timer TB0 SVM output
P7.3/TA1.2	56	59	J12	I/O	General-purpose digital I/O TA1 CCR2 capture: CCI2B input, compare: Out2 output
P8.0/TA0.0	57	60	H9	I/O	General-purpose digital I/O TA0 CCR0 capture: CCI0B input, compare: Out0 output
P8.1/TA0.1	58	61	H11	I/O	General-purpose digital I/O TA0 CCR1 capture: CCI1B input, compare: Out1 output
P8.2/TA0.2	59	62	H12	I/O	General-purpose digital I/O TA0 CCR2 capture: CCI2B input, compare: Out2 output
P8.3/TA0.3	60	63	G9	I/O	General-purpose digital I/O TA0 CCR3 capture: CCI3B input, compare: Out3 output
P8.4/TA0.4	61	64	G11	I/O	General-purpose digital I/O TA0 CCR4 capture: CCI4B input, compare: Out4 output
VCORE ⁽³⁾	62	49	G12		Regulated core power supply output (internal use only, no external current loading)
DVSS2	63	50	F12		Digital ground supply
DVCC2	64	51	E12		Digital power supply
P8.5/TA1.0	65	65	F11	I/O	General-purpose digital I/O TA1 CCR0 capture: CCI0B input, compare: Out0 output
P8.6/TA1.1	66	66	E11	I/O	General-purpose digital I/O TA1 CCR1 capture: CCI1B input, compare: Out1 output

Table 7-1. Signal Descriptions (continued)

TERMINAL				I/O ⁽¹⁾	DESCRIPTION
NAME	NO.				
	PZ	PN	ZCA, ZQW		
P8.7	67	N/A	D12	I/O	General-purpose digital I/O
P9.0/UCB2STE/UCA2CLK	68	N/A	D11	I/O	General-purpose digital I/O Slave transmit enable – USCI_B2 SPI mode Clock signal input – USCI_A2 SPI slave mode Clock signal output – USCI_A2 SPI master mode
P9.1/UCB2SIMO/UCB2SDA	69	N/A	F9	I/O	General-purpose digital I/O Slave in, master out – USCI_B2 SPI mode I ² C data – USCI_B2 I ² C mode
P9.2/UCB2SOMI/UCB2SCL	70	N/A	C12	I/O	General-purpose digital I/O Slave out, master in – USCI_B2 SPI mode I ² C clock – USCI_B2 I ² C mode
P9.3/UCB2CLK/UCA2STE	71	N/A	E9	I/O	General-purpose digital I/O Clock signal input – USCI_B2 SPI slave mode Clock signal output – USCI_B2 SPI master mode Slave transmit enable – USCI_A2 SPI mode
P9.4/UCA2TXD/UCA2SIMO	72	N/A	C11	I/O	General-purpose digital I/O Transmit data – USCI_A2 UART mode Slave in, master out – USCI_A2 SPI mode
P9.5/UCA2RXD/UCA2SOMI	73	N/A	B12	I/O	General-purpose digital I/O Receive data – USCI_A2 UART mode Slave out, master in – USCI_A2 SPI mode
P9.6	74	N/A	B11	I/O	General-purpose digital I/O
P9.7	75	N/A	A12	I/O	General-purpose digital I/O
P10.0/UCB3STE/UCA3CLK	76	N/A	D9	I/O	General-purpose digital I/O Slave transmit enable – USCI_B3 SPI mode Clock signal input – USCI_A3 SPI slave mode Clock signal output – USCI_A3 SPI master mode
P10.1/UCB3SIMO/UCB3SDA	77	N/A	A11	I/O	General-purpose digital I/O Slave in, master out – USCI_B3 SPI mode I ² C data – USCI_B3 I ² C mode
P10.2/UCB3SOMI/UCB3SCL	78	N/A	D8	I/O	General-purpose digital I/O Slave out, master in – USCI_B3 SPI mode I ² C clock – USCI_B3 I ² C mode
P10.3/UCB3CLK/UCA3STE	79	N/A	B10	I/O	General-purpose digital I/O Clock signal input – USCI_B3 SPI slave mode Clock signal output – USCI_B3 SPI master mode Slave transmit enable – USCI_A3 SPI mode
P10.4/UCA3TXD/UCA3SIMO	80	N/A	A10	I/O	General-purpose digital I/O Transmit data – USCI_A3 UART mode Slave in, master out – USCI_A3 SPI mode
P10.5/UCA3RXD/UCA3SOMI	81	N/A	B9	I/O	General-purpose digital I/O Receive data – USCI_A3 UART mode Slave out, master in – USCI_A3 SPI mode
P10.6	82	N/A	A9	I/O	General-purpose digital I/O
P10.7	83	N/A	B8	I/O	General-purpose digital I/O
P11.0/ACLK	84	N/A	A8	I/O	General-purpose digital I/O ACLK output (divided by 1, 2, 4, 8, 16, or 32)
P11.1/MCLK	85	N/A	D7	I/O	General-purpose digital I/O MCLK output
P11.2/SMCLK	86	N/A	A7	I/O	General-purpose digital I/O SMCLK output
DVCC4	87	67	B7		Digital power supply

Table 7-1. Signal Descriptions (continued)

TERMINAL				I/O ⁽¹⁾	DESCRIPTION
NAME	NO.				
	PZ	PN	ZCA, ZQW		
DVSS4	88	68	B6		Digital ground supply
P5.2/XT2IN	89	69	A6	I/O	General-purpose digital I/O Input terminal for crystal oscillator XT2
P5.3/XT2OUT	90	70	A5	I/O	General-purpose digital I/O Output terminal of crystal oscillator XT2
TEST/SBWTCK ⁽⁴⁾	91	71	D6	I	Test mode pin – Selects four wire JTAG operation. Spy-Bi-Wire input clock when Spy-Bi-Wire operation activated
PJ.0/TDO ⁽⁵⁾	92	72	B5	I/O	General-purpose digital I/O JTAG test data output port
PJ.1/TDI/TCLK ⁽⁵⁾	93	73	A4	I/O	General-purpose digital I/O JTAG test data input or test clock input
PJ.2/TMS ⁽⁵⁾	94	74	D5	I/O	General-purpose digital I/O JTAG test mode select
PJ.3/TCK ⁽⁵⁾	95	75	B4	I/O	General-purpose digital I/O JTAG test clock
RST/NMI/SBWDIO ⁽⁴⁾	96	76	A3	I/O	Reset input active low ⁽⁶⁾ Nonmaskable interrupt input Spy-Bi-Wire data input/output when Spy-Bi-Wire operation activated.
P6.0/A0	97	77	D4	I/O	General-purpose digital I/O Analog input A0 for the ADC
P6.1/A1	98	78	B3	I/O	General-purpose digital I/O Analog input A1 for the ADC
P6.2/A2	99	79	A2	I/O	General-purpose digital I/O Analog input A2 for the ADC
P6.3/A3	100	80	B2	I/O	General-purpose digital I/O Analog input A3 for the ADC
Reserved	N/A	N/A	(2)		

- (1) I = input, O = output, N/A = not available on this package offering
(2) C3, E5, E6, E7, E8, F5, F8, G5, G8, H5, H6, H7, H8 are reserved and should be connected to ground.
(3) V_{CORE} is for internal use only. No external current loading is possible. V_{CORE} should be connected to only the recommended capacitor value, C_{V_{CORE}}.
(4) See [Section 9.5](#) and [Section 9.6](#) for use with BSL and JTAG functions, respectively.
(5) See [Section 9.6](#) for use with JTAG function.
(6) When this pin is configured as reset, the internal pullup resistor is enabled by default.

8 Specifications

All graphs in this section are for typical conditions, unless otherwise noted.

Typical (TYP) values are specified at $V_{CC} = 3.3\text{ V}$ and $T_A = 25^\circ\text{C}$, unless otherwise noted.

8.1 Absolute Maximum Ratings

over operating free-air temperature range (unless otherwise noted)

	MIN	MAX	UNIT
Voltage applied at V_{CC} to V_{SS} ⁽¹⁾	-0.3	4.1	V
Voltage applied to any pin (excluding V _{CORE}) ⁽²⁾	-0.3	$V_{CC} + 0.3$	V
Diode current at any device pin		±2	mA
Storage temperature, T_{stg} ⁽³⁾	-55	105	°C
Maximum junction temperature, T_J		95	°C

- (1) Stresses beyond those listed under *Absolute Maximum Ratings* may cause permanent damage to the device. These are stress ratings only, and functional operation of the device at these or any other conditions beyond those indicated under *Recommended Operating Conditions* is not implied. Exposure to absolute-maximum-rated conditions for extended periods may affect device reliability.
- (2) All voltages referenced to V_{SS} . V_{CORE} is for internal device use only. No external DC loading or voltage should be applied.
- (3) Higher temperature may be applied during board soldering according to the current JEDEC J-STD-020 specification with peak reflow temperatures not higher than classified on the device label on the shipping boxes or reels.

8.2 ESD Ratings

		VALUE	UNIT
$V_{(ESD)}$ Electrostatic discharge	Human-body model (HBM), per ANSI/ESDA/JEDEC JS-001 ⁽¹⁾	±1000	V
	Charged-device model (CDM), per JEDEC specification JESD22-C101 ⁽²⁾	±250	

- (1) JEDEC document JEP155 states that 500-V HBM allows safe manufacturing with a standard ESD control process. Pins listed as ±1000 V may actually have higher performance.
- (2) JEDEC document JEP157 states that 250-V CDM allows safe manufacturing with a standard ESD control process. Pins listed as ±250 V may actually have higher performance.

8.3 Recommended Operating Conditions

		MIN	NOM	MAX	UNIT	
V_{CC}	Supply voltage during program execution and flash programming ($AV_{CC} = DV_{CC1/2/3/4} = DV_{CC}$) ^{(1) (2)}	1.8		3.6	V	
V_{SS}	Supply voltage ($AV_{SS} = DV_{SS1/2/3/4} = DV_{SS}$)		0		V	
T_A	Operating free-air temperature	-40		85	°C	
T_J	Operating junction temperature	-40		85	°C	
$C_{V_{CORE}}$	Recommended capacitor at V _{CORE} ⁽³⁾		470		nF	
$C_{DV_{CC}}/C_{V_{CORE}}$	Capacitor ratio of DV _{CC} to V _{CORE}	10				
f_{SYSTEM}	Processor frequency (maximum MCLK frequency) ^{(4) (5)} (see Figure 8-1)	PMMCOREVx = 0, $1.8\text{ V} \leq V_{CC} \leq 3.6\text{ V}$		0	8	MHz
		PMMCOREVx = 1, $2.0\text{ V} \leq V_{CC} \leq 3.6\text{ V}$		0	12	
		PMMCOREVx = 2, $2.2\text{ V} \leq V_{CC} \leq 3.6\text{ V}$		0	20	
		PMMCOREVx = 3, $2.4\text{ V} \leq V_{CC} \leq 3.6\text{ V}$		0	25	

- (1) TI recommends powering AV_{CC} and DV_{CC} from the same source. A maximum difference of 0.3 V between AV_{CC} and DV_{CC} can be tolerated during power up and operation.
- (2) The minimum supply voltage is defined by the supervisor SVS levels when it is enabled. See the [Section 8.23](#) threshold parameters for the exact values and further details.
- (3) A capacitor tolerance of ±20% or better is required.
- (4) The MSP430 CPU is clocked directly with MCLK. Both the high and low phase of MCLK must not exceed the pulse duration of the specified maximum frequency.
- (5) Modules may have a different maximum input clock specification. See the specification of the respective module in this data sheet.

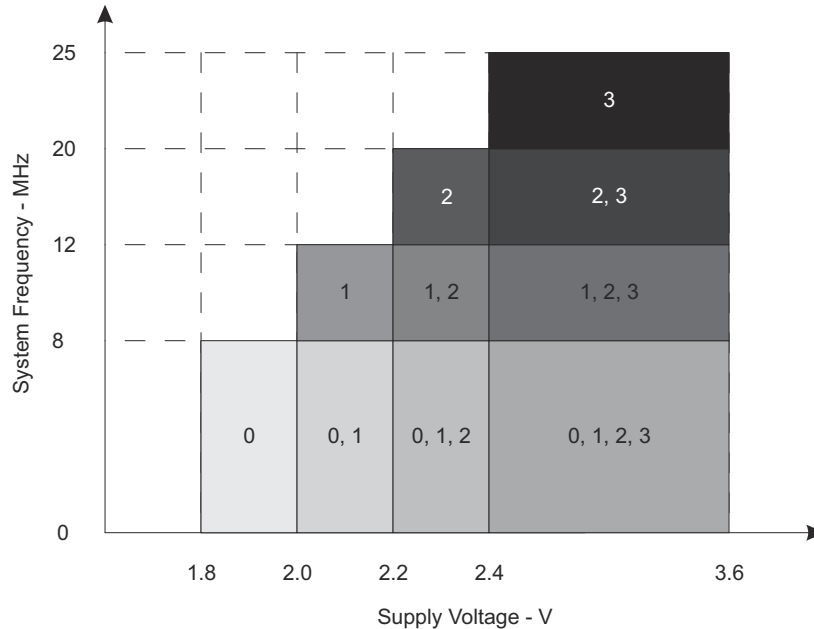

NOTE: The numbers within the fields denote the supported PMMCOREVx settings.

Figure 8-1. Frequency vs Supply Voltage

8.4 Active Mode Supply Current Into V_{CC} Excluding External Current

over recommended operating free-air temperature (unless otherwise noted)^{(1) (2) (3)}

PARAMETER	EXECUTION MEMORY	V_{CC}	PMMCOREVx	FREQUENCY ($f_{DCO} = f_{MCLK} = f_{SMCLK}$)								UNIT		
				1 MHz		8 MHz		12 MHz		20 MHz			25 MHz	
				TYP	MAX	TYP	MAX	TYP	MAX	TYP	MAX		TYP	MAX
$I_{AM, Flash}$	Flash	3.0 V	0	0.29	0.33	1.84	2.08							mA
			1	0.32		2.08		3.10						
			2	0.33		2.24		3.50	6.37					
			3	0.35		2.36		3.70	6.75	8.90	9.60			
$I_{AM, RAM}$	RAM	3.0 V	0	0.17	0.19	0.88	0.99							mA
			1	0.18		1.00		1.47						
			2	0.19		1.13		1.68	2.82					
			3	0.20		1.20		1.78	3.00	4.50	4.90			

- (1) All inputs are tied to 0 V or to V_{CC} . Outputs do not source or sink any current.
- (2) The currents are characterized with a Micro Crystal MS1V-T1K crystal with a load capacitance of 12.5 pF. The internal and external load capacitance are chosen to closely match the required 12.5 pF.
- (3) Characterized with program executing typical data processing.
 $f_{ACLK} = 32768$ Hz, $f_{DCO} = f_{MCLK} = f_{SMCLK}$ at specified frequency.
XTS = CPUOFF = SCG0 = SCG1 = OSCOFF = SMCLKOFF = 0.

8.5 Low-Power Mode Supply Currents (Into V_{CC}) Excluding External Current

over recommended ranges of supply voltage and operating free-air temperature (unless otherwise noted)^{(1) (2)}

PARAMETER	V_{CC}	PMMCOREVx	-40°C		25°C		60°C		85°C		UNIT
			TYP	MAX	TYP	MAX	TYP	MAX	TYP	MAX	
$I_{LPM0,1MHz}$ Low-power mode 0 ^{(3) (9)}	2.2 V	0	69	93	69	93	69	93	69	93	μA
	3.0 V	3	73	100	73	100	73	100	73	100	
I_{LPM2} Low-power mode 2 ^{(4) (9)}	2.2 V	0	11	15.5	11	15.5	11	15.5	11	15.5	μA
	3.0 V	3	11.7	17.5	11.7	17.5	11.7	17.5	11.7	17.5	
$I_{LPM3,XT1LF}$ Low-power mode 3, crystal mode ^{(5) (9)}	2.2 V	0	1.4		1.7		2.6		6.6		μA
		1	1.5		1.8		2.9		9.9		
		2	1.5		2.0		3.3		10.1		
	3.0 V	0	1.8		2.1	2.4	2.8		7.1	13.6	
		1	1.8		2.3		3.1		10.5		
		2	1.9		2.4		3.5		10.6		
$I_{LPM3,VLO}$ Low-power mode 3, VLO mode ^{(6) (9)}	3.0 V	3	2.0		2.3	2.6	3.9		11.8	14.8	
		0	1.0		1.2	1.42	2.0		5.8	12.9	
		1	1.0		1.3		2.3		6.0		
		2	1.1		1.4		2.8		6.2		
I_{LPM4} Low-power mode 4 ^{(7) (9)}	3.0 V	3	1.2		1.4	1.62	3.0		6.2	13.9	
		0	1.1		1.2	1.35	1.9		5.7	12.9	
		1	1.2		1.2		2.2		5.9		
		2	1.3		1.3		2.6		6.1		
$I_{LPM4.5}$ Low-power mode 4.5 ⁽⁸⁾	3.0 V	3	1.3		1.3	1.52	2.9		6.2	13.9	
		0	0.10		0.10	0.13	0.20		0.50	1.14	

- (1) All inputs are tied to 0 V or to V_{CC} . Outputs do not source or sink any current.
- (2) The currents are characterized with a Micro Crystal MS1V-T1K crystal with a load capacitance of 12.5 pF. The internal and external load capacitance are chosen to closely match the required 12.5 pF.
- (3) Current for watchdog timer clocked by SMCLK included. ACLK = low-frequency crystal operation (XTS = 0, XT1DRIVE_x = 0). CPUOFF = 1, SCG0 = 0, SCG1 = 0, OSCOFF = 0 (LPM0), f_{ACLK} = 32768 Hz, f_{MCLK} = 0 MHz, f_{SMCLK} = f_{DCO} = 1 MHz
- (4) Current for watchdog timer and RTC clocked by ACLK included. ACLK = low-frequency crystal operation (XTS = 0, XT1DRIVE_x = 0). CPUOFF = 1, SCG0 = 0, SCG1 = 1, OSCOFF = 0 (LPM2), f_{ACLK} = 32768 Hz, f_{MCLK} = 0 MHz, f_{SMCLK} = f_{DCO} = 0 MHz, DCO setting = 1 MHz operation, DCO bias generator enabled.
- (5) Current for watchdog timer and RTC clocked by ACLK included. ACLK = low-frequency crystal operation (XTS = 0, XT1DRIVE_x = 0). CPUOFF = 1, SCG0 = 1, SCG1 = 1, OSCOFF = 0 (LPM3), f_{ACLK} = 32768 Hz, f_{MCLK} = f_{SMCLK} = f_{DCO} = 0 MHz
- (6) Current for watchdog timer and RTC clocked by ACLK included. ACLK = VLO. CPUOFF = 1, SCG0 = 1, SCG1 = 1, OSCOFF = 0 (LPM3), f_{ACLK} = f_{VLO} , f_{MCLK} = f_{SMCLK} = f_{DCO} = 0 MHz
- (7) CPUOFF = 1, SCG0 = 1, SCG1 = 1, OSCOFF = 1 (LPM4), f_{DCO} = f_{ACLK} = f_{MCLK} = f_{SMCLK} = 0 MHz
- (8) Internal regulator disabled. No data retention. CPUOFF = 1, SCG0 = 1, SCG1 = 1, OSCOFF = 1, PMMREGOFF = 1 (LPM4.5), f_{DCO} = f_{ACLK} = f_{MCLK} = f_{SMCLK} = 0 MHz
- (9) Current for brownout, high side supervisor (SVSH) normal mode included. Low-side supervisor (SVSL) and low-side monitor (SVM_L) disabled. High-side monitor (SVM_H) disabled. RAM retention enabled.

8.6 Thermal Resistance Characteristics

THERMAL METRIC			VALUE	UNIT	
R θ_{JA}	Junction-to-ambient thermal resistance, still air	Low-K board (JESD51-3)	LQFP (PZ)	50.1	°C/W
			LQFP (PN)	57.9	
			BGA (ZQW)	60	
	High-K board (JESD51-7)	LQFP (PZ)	40.8		
		LQFP (PN)	37.9		
		BGA (ZQW)	42		
See (1) and (2)	nFBGA (ZCA)	36.2			
R θ_{JC}	Junction-to-case thermal resistance (1) (2)	LQFP (PZ)	8.9	°C/W	
		LQFP (PN)	10.3		
		BGA (ZQW)	8		
R θ_{JcTop}	Junction-to-case (top) thermal resistance (1) (2)		13.5	°C/W	
R θ_{JB}	Junction-to-board thermal resistance (1) (2)		14.5	°C/W	
Ψ_{JT}	Junction-to-top characterization parameter (1) (2)		0.3	°C/W	
Ψ_{JB}	Junction-to-board characterization parameter (1) (2)		14.3	°C/W	

- (1) For more information about traditional and new thermal metrics, see the [Semiconductor and IC Package Thermal Metrics application report](#).
(2) For thermal estimates of this device based on PCB copper area, see the [TI PCB Thermal Calculator](#).

8.7 Schmitt-Trigger Inputs – General-Purpose I/O

over recommended ranges of supply voltage and operating free-air temperature (unless otherwise noted)

PARAMETER ⁽¹⁾	TEST CONDITIONS	V _{CC}	MIN	TYP	MAX	UNIT
V _{IT+}	Positive-going input threshold voltage	1.8 V	0.80		1.40	V
		3 V	1.50		2.10	
V _{IT-}	Negative-going input threshold voltage	1.8 V	0.45		1.00	V
		3 V	0.75		1.65	
V _{hys}	Input voltage hysteresis (V _{IT+} – V _{IT-})	1.8 V	0.3		0.85	V
		3 V	0.4		1.0	
R _{Pull}	Pullup or pulldown resistor ⁽²⁾	For pullup: V _{IN} = V _{SS} For pulldown: V _{IN} = V _{CC}	20	35	50	k Ω
C _I	Input capacitance	V _{IN} = V _{SS} or V _{CC}		5		pF

- (1) Same parametrics apply to clock input pin when crystal bypass mode is used on XT1 (XIN) or XT2 (XT2IN).
(2) Also applies to the \overline{RST} pin when the pullup or pulldown resistor is enabled.

8.8 Inputs – Ports P1 and P2

over recommended ranges of supply voltage and operating free-air temperature (unless otherwise noted)

PARAMETER ⁽¹⁾	TEST CONDITIONS	V _{CC}	MIN	MAX	UNIT
t _(int)	External interrupt timing ⁽²⁾	Port P1, P2: P1.x to P2.x, external trigger pulse duration to set interrupt flag	2.2 V, 3 V	20	ns

- (1) Some devices may contain additional ports with interrupts. See the block diagram (see [Section 4](#)) and signal descriptions (see [Section 7.2](#)).
(2) An external signal sets the interrupt flag every time the minimum interrupt pulse duration t_(int) is met. It may be set by trigger signals shorter than t_(int).

8.9 Leakage Current – General-Purpose I/O

over recommended ranges of supply voltage and operating free-air temperature (unless otherwise noted)

PARAMETER		TEST CONDITIONS	V _{CC}	MIN	MAX	UNIT
I _{lkg(Px,y)}	High-impedance leakage current	See (1) (2)	1.8 V, 3 V		±50	nA

- (1) The leakage current is measured with V_{SS} or V_{CC} applied to the corresponding pins, unless otherwise noted.
 (2) The leakage of the digital port pins is measured individually. The port pin is selected for input and the pullup or pulldown resistor is disabled.

8.10 Outputs – General-Purpose I/O (Full Drive Strength)

over recommended ranges of supply voltage and operating free-air temperature (unless otherwise noted)

PARAMETER		TEST CONDITIONS	V _{CC}	MIN	MAX	UNIT
V _{OH}	High-level output voltage	I _(OHmax) = -3 mA ⁽¹⁾	1.8 V	V _{CC} - 0.25	V _{CC}	V
		I _(OHmax) = -10 mA ⁽²⁾		V _{CC} - 0.60	V _{CC}	
		I _(OHmax) = -5 mA ⁽¹⁾	3 V	V _{CC} - 0.25	V _{CC}	
		I _(OHmax) = -15 mA ⁽²⁾		V _{CC} - 0.60	V _{CC}	
V _{OL}	Low-level output voltage	I _(OLmax) = 3 mA ⁽¹⁾	1.8 V	V _{SS}	V _{SS} + 0.25	V
		I _(OLmax) = 10 mA ⁽²⁾		V _{SS}	V _{SS} + 0.60	
		I _(OLmax) = 5 mA ⁽¹⁾	3 V	V _{SS}	V _{SS} + 0.25	
		I _(OLmax) = 15 mA ⁽²⁾		V _{SS}	V _{SS} + 0.60	

- (1) The maximum total current, I_(OHmax) and I_(OLmax), for all outputs combined should not exceed ±48 mA to hold the maximum voltage drop specified.
- (2) The maximum total current, I_(OHmax) and I_(OLmax), for all outputs combined should not exceed ±100 mA to hold the maximum voltage drop specified.

8.11 Outputs – General-Purpose I/O (Reduced Drive Strength)

over recommended ranges of supply voltage and operating free-air temperature (unless otherwise noted)⁽³⁾

PARAMETER		TEST CONDITIONS	V _{CC}	MIN	MAX	UNIT
V _{OH}	High-level output voltage	I _(OHmax) = -1 mA ⁽¹⁾	1.8 V	V _{CC} - 0.25	V _{CC}	V
		I _(OHmax) = -3 mA ⁽²⁾		V _{CC} - 0.60	V _{CC}	
		I _(OHmax) = -2 mA ⁽¹⁾	3.0 V	V _{CC} - 0.25	V _{CC}	
		I _(OHmax) = -6 mA ⁽²⁾		V _{CC} - 0.60	V _{CC}	
V _{OL}	Low-level output voltage	I _(OLmax) = 1 mA ⁽¹⁾	1.8 V	V _{SS}	V _{SS} + 0.25	V
		I _(OLmax) = 3 mA ⁽²⁾		V _{SS}	V _{SS} + 0.60	
		I _(OLmax) = 2 mA ⁽¹⁾	3.0 V	V _{SS}	V _{SS} + 0.25	
		I _(OLmax) = 6 mA ⁽²⁾		V _{SS}	V _{SS} + 0.60	

- (1) The maximum total current, I_(OHmax) and I_(OLmax), for all outputs combined, should not exceed ±48 mA to hold the maximum voltage drop specified.
- (2) The maximum total current, I_(OHmax) and I_(OLmax), for all outputs combined, should not exceed ±100 mA to hold the maximum voltage drop specified.
- (3) Selecting reduced drive strength may reduce EMI.

8.12 Output Frequency – General-Purpose I/O

over recommended ranges of supply voltage and operating free-air temperature (unless otherwise noted)

PARAMETER		TEST CONDITIONS	MIN	MAX	UNIT
f _{Px.y}	Port output frequency (with load)	P1.6/SMCLK ⁽¹⁾ ⁽²⁾	V _{CC} = 1.8 V, PMMCOREV _x = 0	16	MHz
			V _{CC} = 3 V, PMMCOREV _x = 3	25	
f _{Port_CLK}	Clock output frequency	P1.0/TA0CLK/ACLK P1.6/SMCLK P2.0/TA1CLK/MCLK C _L = 20 pF ⁽²⁾	V _{CC} = 1.8 V, PMMCOREV _x = 0	16	MHz
			V _{CC} = 3 V, PMMCOREV _x = 3	25	

- (1) A resistive divider with 2 × R₁ between V_{CC} and V_{SS} is used as load. The output is connected to the center tap of the divider. For full drive strength, R₁ = 550 Ω. For reduced drive strength, R₁ = 1.6 kΩ. C_L = 20 pF is connected to the output to V_{SS}.
- (2) The output voltage reaches at least 10% and 90% V_{CC} at the specified toggle frequency.

8.13 Typical Characteristics – Outputs, Reduced Drive Strength (PxDS.y = 0)

over recommended ranges of supply voltage and operating free-air temperature (unless otherwise noted)

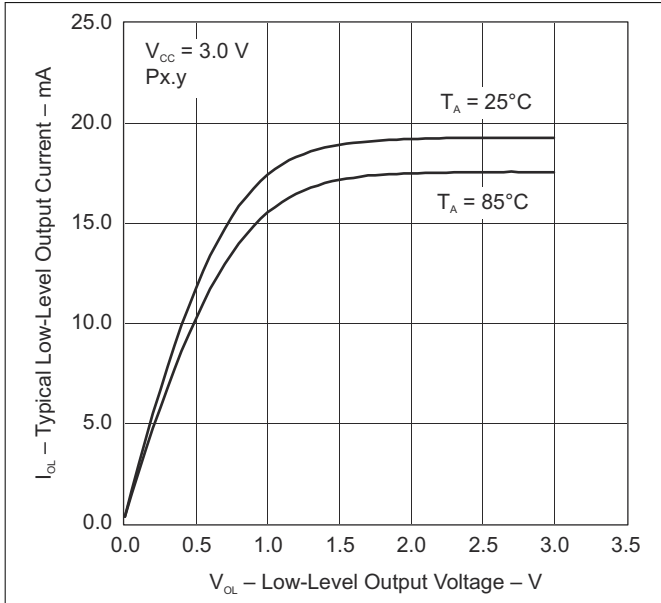

Figure 8-2. Typical Low-Level Output Current vs Low-Level Output Voltage

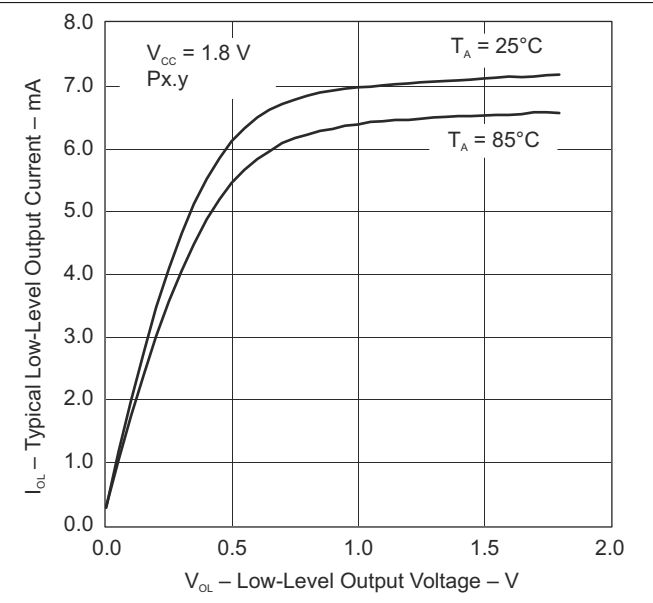

Figure 8-3. Typical Low-Level Output Current vs Low-Level Output Voltage

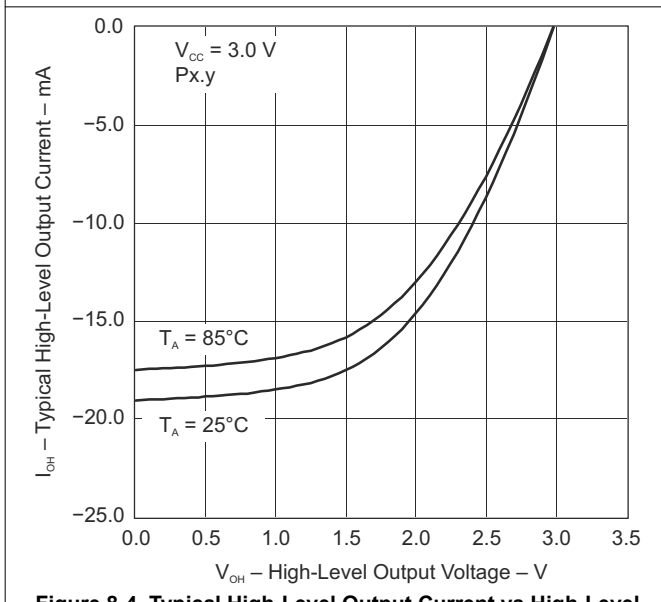

Figure 8-4. Typical High-Level Output Current vs High-Level Output Voltage

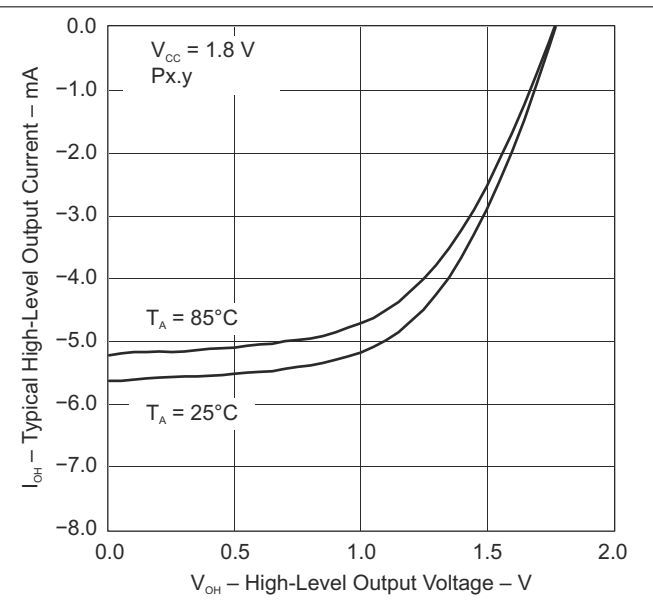

Figure 8-5. Typical High-Level Output Current vs High-Level Output Voltage

8.14 Typical Characteristics – Outputs, Full Drive Strength (PxDS.y = 1)

over recommended ranges of supply voltage and operating free-air temperature (unless otherwise noted)

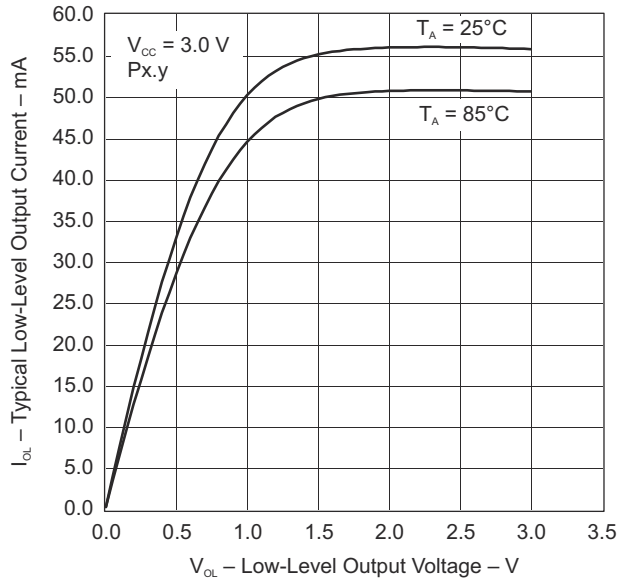

Figure 8-6. Typical Low-Level Output Current vs Low-Level Output Voltage

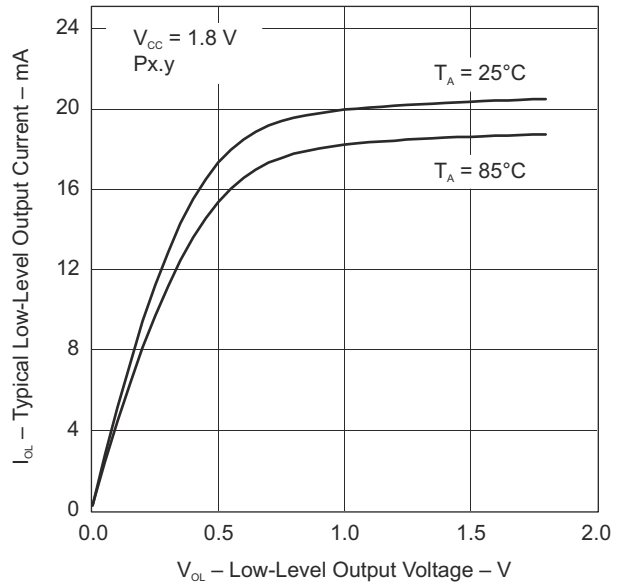

Figure 8-7. Typical Low-Level Output Current vs Low-Level Output Voltage

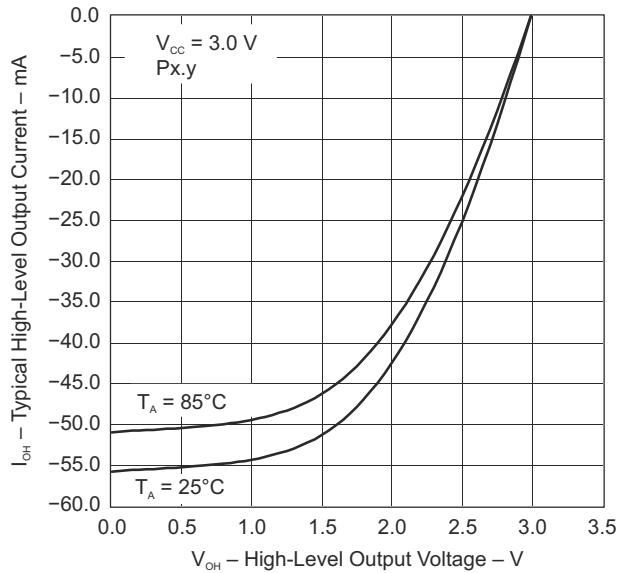

Figure 8-8. Typical High-Level Output Current vs High-Level Output Voltage

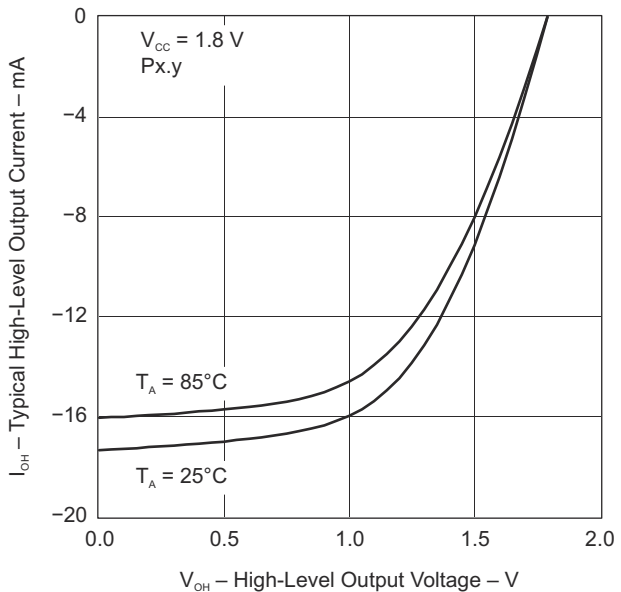

Figure 8-9. Typical High-Level Output Current vs High-Level Output Voltage

8.15 Crystal Oscillator, XT1, Low-Frequency Mode

over recommended ranges of supply voltage and operating free-air temperature (unless otherwise noted)

PARAMETER ⁽¹⁾	TEST CONDITIONS	V _{CC}	MIN	TYP	MAX	UNIT
$\Delta I_{DVCC,LF}$ Differential XT1 oscillator crystal current consumption from lowest drive setting, LF mode	$f_{OSC} = 32768$ Hz, XTS = 0, XT1BYPASS = 0, XT1DRIVE _x = 1, T _A = 25°C	3.0 V		0.075		μA
	$f_{OSC} = 32768$ Hz, XTS = 0, XT1BYPASS = 0, XT1DRIVE _x = 2, T _A = 25°C			0.170		
	$f_{OSC} = 32768$ Hz, XTS = 0, XT1BYPASS = 0, XT1DRIVE _x = 3, T _A = 25°C			0.290		
$f_{XT1,LF0}$ XT1 oscillator crystal frequency, LF mode	XTS = 0, XT1BYPASS = 0			32768		Hz
$f_{XT1,LF,SW}$ XT1 oscillator logic-level square-wave input frequency, LF mode	XTS = 0, XT1BYPASS = 1 ⁽²⁾ ⁽³⁾		10	32.768	50	kHz
OA_{LF} Oscillation allowance for LF crystals ⁽⁴⁾	XTS = 0, XT1BYPASS = 0, XT1DRIVE _x = 0, $f_{XT1,LF} = 32768$ Hz, C _{L,eff} = 6 pF			210		kΩ
	XTS = 0, XT1BYPASS = 0, XT1DRIVE _x = 1, $f_{XT1,LF} = 32768$ Hz, C _{L,eff} = 12 pF			300		
$C_{L,eff}$ Integrated effective load capacitance, LF mode ⁽⁵⁾	XTS = 0, XCAP _x = 0 ⁽⁶⁾			1		pF
	XTS = 0, XCAP _x = 1			5.5		
	XTS = 0, XCAP _x = 2			8.5		
	XTS = 0, XCAP _x = 3			12.0		
Duty cycle, LF mode	XTS = 0, Measured at ACLK, $f_{XT1,LF} = 32768$ Hz		30%		70%	
$f_{Fault,LF}$ Oscillator fault frequency, LF mode ⁽⁷⁾	XTS = 0 ⁽⁸⁾		10		10000	Hz
$t_{START,LF}$ Start-up time, LF mode	$f_{OSC} = 32768$ Hz, XTS = 0, XT1BYPASS = 0, XT1DRIVE _x = 0, T _A = 25°C, C _{L,eff} = 6 pF	3.0 V		1000		ms
	$f_{OSC} = 32768$ Hz, XTS = 0, XT1BYPASS = 0, XT1DRIVE _x = 3, T _A = 25°C, C _{L,eff} = 12 pF			500		

- (1) To improve EMI on the XT1 oscillator, the following guidelines should be observed.
- Keep the trace between the device and the crystal as short as possible.
 - Design a good ground plane around the oscillator pins.
 - Prevent crosstalk from other clock or data lines into oscillator pins XIN and XOUT.
 - Avoid running PCB traces underneath or adjacent to the XIN and XOUT pins.
 - Use assembly materials and processes that avoid any parasitic load on the oscillator XIN and XOUT pins.
 - If conformal coating is used, make sure that it does not induce capacitive or resistive leakage between the oscillator pins.
- (2) When XT1BYPASS is set, XT1 circuits are automatically powered down. Input signal is a digital square wave with parametrics defined in the Schmitt-trigger Inputs section of this data sheet.
- (3) Maximum frequency of operation of the entire device cannot be exceeded.
- (4) Oscillation allowance is based on a safety factor of 5 for recommended crystals. The oscillation allowance is a function of the XT1DRIVE_x settings and the effective load. In general, comparable oscillator allowance can be achieved based on the following guidelines, but should be evaluated based on the actual crystal selected for the application:
- For XT1DRIVE_x = 0, C_{L,eff} ≤ 6 pF.
 - For XT1DRIVE_x = 1, 6 pF ≤ C_{L,eff} ≤ 9 pF.
 - For XT1DRIVE_x = 2, 6 pF ≤ C_{L,eff} ≤ 10 pF.
 - For XT1DRIVE_x = 3, C_{L,eff} ≥ 6 pF.
- (5) Includes parasitic bond and package capacitance (approximately 2 pF per pin). Because the PCB adds additional capacitance, verify the correct load by measuring the ACLK frequency. For a correct setup, the effective load capacitance should always match the specification of the used crystal.
- (6) Requires external capacitors at both terminals. Values are specified by crystal manufacturers.
- (7) Frequencies below the MIN specification set the fault flag. Frequencies above the MAX specification do not set the fault flag. Frequencies between the MIN and MAX specifications might set the flag.
- (8) Measured with logic-level input frequency but also applies to operation with crystals.

8.16 Crystal Oscillator, XT1, High-Frequency Mode

over recommended ranges of supply voltage and operating free-air temperature (unless otherwise noted)

PARAMETER ⁽¹⁾		TEST CONDITIONS	V _{CC}	MIN	TYP	MAX	UNIT
I _{DVCC,HF}	XT1 oscillator crystal current, HF mode	f _{OSC} = 4 MHz, XTS = 1, XOSCOFF = 0, XT1BYPASS = 0, XT1DRIVE _x = 0, T _A = 25°C	3.0 V		200		μA
		f _{OSC} = 12 MHz, XTS = 1, XOSCOFF = 0, XT1BYPASS = 0, XT1DRIVE _x = 1, T _A = 25°C			260		
		f _{OSC} = 20 MHz, XTS = 1, XOSCOFF = 0, XT1BYPASS = 0, XT1DRIVE _x = 2, T _A = 25°C			325		
		f _{OSC} = 32 MHz, XTS = 1, XOSCOFF = 0, XT1BYPASS = 0, XT1DRIVE _x = 3, T _A = 25°C			450		
f _{XT1,HF0}	XT1 oscillator crystal frequency, HF mode 0	XTS = 1, XT1BYPASS = 0, XT1DRIVE _x = 0 ⁽²⁾		4		8	MHz
f _{XT1,HF1}	XT1 oscillator crystal frequency, HF mode 1	XTS = 1, XT1BYPASS = 0, XT1DRIVE _x = 1 ⁽²⁾		8		16	MHz
f _{XT1,HF2}	XT1 oscillator crystal frequency, HF mode 2	XTS = 1, XT1BYPASS = 0, XT1DRIVE _x = 2 ⁽²⁾		16		24	MHz
f _{XT1,HF3}	XT1 oscillator crystal frequency, HF mode 3	XTS = 1, XT1BYPASS = 0, XT1DRIVE _x = 3 ⁽²⁾		24		32	MHz
f _{XT1,HF,SW}	XT1 oscillator logic-level square-wave input frequency, HF mode, bypass mode	XTS = 1, XT1BYPASS = 1 ⁽³⁾ ⁽²⁾		0.7		32	MHz
O _{AHF}	Oscillation allowance for HF crystals ⁽⁴⁾	XTS = 1, XT1BYPASS = 0, XT1DRIVE _x = 0, f _{XT1,HF} = 6 MHz, C _{L,eff} = 15 pF			450		Ω
		XTS = 1, XT1BYPASS = 0, XT1DRIVE _x = 1, f _{XT1,HF} = 12 MHz, C _{L,eff} = 15 pF			320		
		XTS = 1, XT1BYPASS = 0, XT1DRIVE _x = 2, f _{XT1,HF} = 20 MHz, C _{L,eff} = 15 pF			200		
		XTS = 1, XT1BYPASS = 0, XT1DRIVE _x = 3, f _{XT1,HF} = 32 MHz, C _{L,eff} = 15 pF			200		
t _{START,HF}	Start-up time, HF mode	f _{OSC} = 6 MHz, XTS = 1, XT1BYPASS = 0, XT1DRIVE _x = 0, T _A = 25°C, C _{L,eff} = 15 pF	3.0 V		0.5		ms
		f _{OSC} = 20 MHz, XTS = 1, XT1BYPASS = 0, XT1DRIVE _x = 2, T _A = 25°C, C _{L,eff} = 15 pF			0.3		
C _{L,eff}	Integrated effective load capacitance, HF mode ⁽⁵⁾ ⁽⁶⁾	XTS = 1			1		pF
	Duty cycle, HF mode	XTS = 1, Measured at ACLK, f _{XT1,HF2} = 20 MHz		40%	50%	60%	
f _{FAULT,HF}	Oscillator fault frequency, HF mode ⁽⁷⁾	XTS = 1 ⁽⁸⁾		30		300	kHz

(1) To improve EMI on the XT1 oscillator the following guidelines should be observed.

- Keep the traces between the device and the crystal as short as possible.
- Design a good ground plane around the oscillator pins.
- Prevent crosstalk from other clock or data lines into oscillator pins XIN and XOUT.
- Avoid running PCB traces underneath or adjacent to the XIN and XOUT pins.
- Use assembly materials and processes that avoid any parasitic load on the oscillator XIN and XOUT pins.
- If conformal coating is used, make sure that it does not induce capacitive or resistive leakage between the oscillator pins.

(2) This represents the maximum frequency that can be input to the device externally. Maximum frequency achievable on the device operation is based on the frequencies present on ACLK, MCLK, and SMCLK cannot be exceeded for a given range of operation.

- (3) When XT1BYPASS is set, XT1 circuits are automatically powered down. Input signal is a digital square wave with parametrics defined in the Schmitt-trigger Inputs section of this data sheet.
- (4) Oscillation allowance is based on a safety factor of 5 for recommended crystals.
- (5) Includes parasitic bond and package capacitance (approximately 2 pF per pin). Because the PCB adds additional capacitance, verify the correct load by measuring the ACLK frequency. For a correct setup, the effective load capacitance should always match the specification of the used crystal.
- (6) Requires external capacitors at both terminals. Values are specified by crystal manufacturers. In general, an effective load capacitance of up to 18 pF can be supported.
- (7) Frequencies below the MIN specification set the fault flag. Frequencies above the MAX specification do not set the fault flag. Frequencies between the MIN and MAX specifications might set the flag.
- (8) Measured with logic-level input frequency but also applies to operation with crystals.

8.17 Crystal Oscillator, XT2

over recommended ranges of supply voltage and operating free-air temperature (unless otherwise noted)^{(1) (2)}

PARAMETER		TEST CONDITIONS	V _{CC}	MIN	TYP	MAX	UNIT
I _{DVCC,XT2}	XT2 oscillator crystal current consumption	f _{OSC} = 4 MHz, XT2OFF = 0, XT2BYPASS = 0, XT2DRIVE _x = 0, T _A = 25°C	3.0 V		200		μA
		f _{OSC} = 12 MHz, XT2OFF = 0, XT2BYPASS = 0, XT2DRIVE _x = 1, T _A = 25°C			260		
		f _{OSC} = 20 MHz, XT2OFF = 0, XT2BYPASS = 0, XT2DRIVE _x = 2, T _A = 25°C			325		
		f _{OSC} = 32 MHz, XT2OFF = 0, XT2BYPASS = 0, XT2DRIVE _x = 3, T _A = 25°C			450		
f _{XT2,HF0}	XT2 oscillator crystal frequency, mode 0	XT2DRIVE _x = 0, XT2BYPASS = 0 ⁽³⁾		4		8	MHz
f _{XT2,HF1}	XT2 oscillator crystal frequency, mode 1	XT2DRIVE _x = 1, XT2BYPASS = 0 ⁽³⁾		8		16	MHz
f _{XT2,HF2}	XT2 oscillator crystal frequency, mode 2	XT2DRIVE _x = 2, XT2BYPASS = 0 ⁽³⁾		16		24	MHz
f _{XT2,HF3}	XT2 oscillator crystal frequency, mode 3	XT2DRIVE _x = 3, XT2BYPASS = 0 ⁽³⁾		24		32	MHz
f _{XT2,HF,SW}	XT2 oscillator logic-level square-wave input frequency, bypass mode	XT2BYPASS = 1 ^{(4) (3)}		0.7		32	MHz
O _{A,HF}	Oscillation allowance for HF crystals ⁽⁵⁾	XT2DRIVE _x = 0, XT2BYPASS = 0, f _{XT2,HF0} = 6 MHz, C _{L,eff} = 15 pF			450		Ω
		XT2DRIVE _x = 1, XT2BYPASS = 0, f _{XT2,HF1} = 12 MHz, C _{L,eff} = 15 pF			320		
		XT2DRIVE _x = 2, XT2BYPASS = 0, f _{XT2,HF2} = 20 MHz, C _{L,eff} = 15 pF			200		
		XT2DRIVE _x = 3, XT2BYPASS = 0, f _{XT2,HF3} = 32 MHz, C _{L,eff} = 15 pF			200		
t _{START,HF}	Start-up time	f _{OSC} = 6 MHz, XT2BYPASS = 0, XT2DRIVE _x = 0, T _A = 25°C, C _{L,eff} = 15 pF	3.0 V		0.5		ms
		f _{OSC} = 20 MHz, XT2BYPASS = 0, XT2DRIVE _x = 2, T _A = 25°C, C _{L,eff} = 15 pF			0.3		
C _{L,eff}	Integrated effective load capacitance, HF mode ^{(6) (1)}				1		pF
	Duty cycle	Measured at ACLK, f _{XT2,HF2} = 20 MHz		40%	50%	60%	
f _{Fault,HF}	Oscillator fault frequency ⁽⁷⁾	XT2BYPASS = 1 ⁽⁸⁾		30		300	kHz

- (1) Requires external capacitors at both terminals. Values are specified by crystal manufacturers. In general, an effective load capacitance of up to 18 pF can be supported.
- (2) To improve EMI on the XT2 oscillator the following guidelines should be observed.

- Keep the traces between the device and the crystal as short as possible.
 - Design a good ground plane around the oscillator pins.
 - Prevent crosstalk from other clock or data lines into oscillator pins XT2IN and XT2OUT.
 - Avoid running PCB traces underneath or adjacent to the XT2IN and XT2OUT pins.
 - Use assembly materials and processes that avoid any parasitic load on the oscillator XT2IN and XT2OUT pins.
 - If conformal coating is used, make sure that it does not induce capacitive or resistive leakage between the oscillator pins.
- (3) This represents the maximum frequency that can be input to the device externally. Maximum frequency achievable on the device operation is based on the frequencies present on ACLK, MCLK, and SMCLK cannot be exceed for a given range of operation.
 - (4) When XT2BYPASS is set, the XT2 circuit is automatically powered down. Input signal is a digital square wave with parametrics defined in the Schmitt-trigger Inputs section of this data sheet.
 - (5) Oscillation allowance is based on a safety factor of 5 for recommended crystals.
 - (6) Includes parasitic bond and package capacitance (approximately 2 pF per pin).
Because the PCB adds additional capacitance, verify the correct load by measuring the ACLK frequency. For a correct setup, the effective load capacitance should always match the specification of the used crystal.
 - (7) Frequencies below the MIN specification set the fault flag. Frequencies above the MAX specification do not set the fault flag. Frequencies between the MIN and MAX specifications might set the flag.
 - (8) Measured with logic-level input frequency but also applies to operation with crystals.

8.18 Internal Very-Low-Power Low-Frequency Oscillator (VLO)

over recommended ranges of supply voltage and operating free-air temperature (unless otherwise noted)

PARAMETER		TEST CONDITIONS	V _{CC}	MIN	TYP	MAX	UNIT
f _{VLO}	VLO frequency	Measured at ACLK	1.8 V to 3.6 V	6	9.4	14	kHz
df _{VLO} /dT	VLO frequency temperature drift	Measured at ACLK ⁽¹⁾	1.8 V to 3.6 V		0.5		%/°C
df _{VLO} /dV _{CC}	VLO frequency supply voltage drift	Measured at ACLK ⁽²⁾	1.8 V to 3.6 V		4		%/V
	Duty cycle	Measured at ACLK	1.8 V to 3.6 V	40%	50%	60%	

(1) Calculated using the box method: (MAX(−40°C to 85°C) – MIN(−40°C to 85°C)) / MIN(−40°C to 85°C) / (85°C – (−40°C))

(2) Calculated using the box method: (MAX(1.8 V to 3.6 V) – MIN(1.8 V to 3.6 V)) / MIN(1.8 V to 3.6 V) / (3.6 V – 1.8 V)

8.19 Internal Reference, Low-Frequency Oscillator (REFO)

over recommended ranges of supply voltage and operating free-air temperature (unless otherwise noted)

PARAMETER		TEST CONDITIONS	V _{CC}	MIN	TYP	MAX	UNIT
I _{REFO}	REFO oscillator current consumption	T _A = 25°C	1.8 V to 3.6 V		3		μA
f _{REFO}	REFO frequency calibrated	Measured at ACLK	1.8 V to 3.6 V		32768		Hz
	REFO absolute tolerance calibrated	Full temperature range	1.8 V to 3.6 V			±3.5%	
		T _A = 25°C	3 V			±1.5%	
df _{REFO} /dT	REFO frequency temperature drift	Measured at ACLK ⁽¹⁾	1.8 V to 3.6 V		0.01		%/°C
df _{REFO} /dV _{CC}	REFO frequency supply voltage drift	Measured at ACLK ⁽²⁾	1.8 V to 3.6 V		1.0		%/V
	Duty cycle	Measured at ACLK	1.8 V to 3.6 V	40%	50%	60%	
t _{START}	REFO start-up time	40%/60% duty cycle	1.8 V to 3.6 V		25		μs

(1) Calculated using the box method: (MAX(−40°C to 85°C) – MIN(−40°C to 85°C)) / MIN(−40°C to 85°C) / (85°C – (−40°C))

(2) Calculated using the box method: (MAX(1.8 V to 3.6 V) – MIN(1.8 V to 3.6 V)) / MIN(1.8 V to 3.6 V) / (3.6 V – 1.8 V)

8.20 DCO Frequency

over recommended ranges of supply voltage and operating free-air temperature (unless otherwise noted)

PARAMETER	TEST CONDITIONS	MIN	TYP	MAX	UNIT
$f_{DCO(0,0)}$	DCO frequency (0, 0) ⁽¹⁾	DCORSELx = 0, DCOx = 0, MODx = 0	0.07	0.20	MHz
$f_{DCO(0,31)}$	DCO frequency (0, 31) ⁽¹⁾	DCORSELx = 0, DCOx = 31, MODx = 0	0.70	1.70	MHz
$f_{DCO(1,0)}$	DCO frequency (1, 0) ⁽¹⁾	DCORSELx = 1, DCOx = 0, MODx = 0	0.15	0.36	MHz
$f_{DCO(1,31)}$	DCO frequency (1, 31) ⁽¹⁾	DCORSELx = 1, DCOx = 31, MODx = 0	1.47	3.45	MHz
$f_{DCO(2,0)}$	DCO frequency (2, 0) ⁽¹⁾	DCORSELx = 2, DCOx = 0, MODx = 0	0.32	0.75	MHz
$f_{DCO(2,31)}$	DCO frequency (2, 31) ⁽¹⁾	DCORSELx = 2, DCOx = 31, MODx = 0	3.17	7.38	MHz
$f_{DCO(3,0)}$	DCO frequency (3, 0) ⁽¹⁾	DCORSELx = 3, DCOx = 0, MODx = 0	0.64	1.51	MHz
$f_{DCO(3,31)}$	DCO frequency (3, 31) ⁽¹⁾	DCORSELx = 3, DCOx = 31, MODx = 0	6.07	14.0	MHz
$f_{DCO(4,0)}$	DCO frequency (4, 0) ⁽¹⁾	DCORSELx = 4, DCOx = 0, MODx = 0	1.3	3.2	MHz
$f_{DCO(4,31)}$	DCO frequency (4, 31) ⁽¹⁾	DCORSELx = 4, DCOx = 31, MODx = 0	12.3	28.2	MHz
$f_{DCO(5,0)}$	DCO frequency (5, 0) ⁽¹⁾	DCORSELx = 5, DCOx = 0, MODx = 0	2.5	6.0	MHz
$f_{DCO(5,31)}$	DCO frequency (5, 31) ⁽¹⁾	DCORSELx = 5, DCOx = 31, MODx = 0	23.7	54.1	MHz
$f_{DCO(6,0)}$	DCO frequency (6, 0) ⁽¹⁾	DCORSELx = 6, DCOx = 0, MODx = 0	4.6	10.7	MHz
$f_{DCO(6,31)}$	DCO frequency (6, 31) ⁽¹⁾	DCORSELx = 6, DCOx = 31, MODx = 0	39.0	88.0	MHz
$f_{DCO(7,0)}$	DCO frequency (7, 0) ⁽¹⁾	DCORSELx = 7, DCOx = 0, MODx = 0	8.5	19.6	MHz
$f_{DCO(7,31)}$	DCO frequency (7, 31) ⁽¹⁾	DCORSELx = 7, DCOx = 31, MODx = 0	60	135	MHz
$S_{DCORSEL}$	Frequency step between range DCORSEL and DCORSEL + 1	$S_{RSEL} = f_{DCO(DCORSEL+1,DCO)} / f_{DCO(DCORSEL,DCO)}$	1.2	2.3	ratio
S_{DCO}	Frequency step between tap DCO and DCO + 1	$S_{DCO} = f_{DCO(DCORSEL,DCO+1)} / f_{DCO(DCORSEL,DCO)}$	1.02	1.12	ratio
	Duty cycle	Measured at SMCLK	40%	50%	60%
df_{DCO}/dT	DCO frequency temperature drift ⁽²⁾	$f_{DCO} = 1$ MHz		0.1	%/°C
df_{DCO}/dV_{CC}	DCO frequency voltage drift ⁽³⁾	$f_{DCO} = 1$ MHz		1.9	%/V

- (1) When selecting the proper DCO frequency range (DCORSELx), the target DCO frequency, f_{DCO} , should be set to reside within the range of $f_{DCO(n,0),MAX} \leq f_{DCO} \leq f_{DCO(n,31),MIN}$, where $f_{DCO(n,0),MAX}$ represents the maximum frequency specified for the DCO frequency, range n, tap 0 (DCOx = 0) and $f_{DCO(n,31),MIN}$ represents the minimum frequency specified for the DCO frequency, range n, tap 31 (DCOx = 31). This ensures that the target DCO frequency resides within the range selected. It should also be noted that if the actual f_{DCO} frequency for the selected range causes the FLL or the application to select tap 0 or 31, the DCO fault flag is set to report that the selected range is at its minimum or maximum tap setting.
- (2) Calculated using the box method: $(MAX(-40^{\circ}C \text{ to } 85^{\circ}C) - MIN(-40^{\circ}C \text{ to } 85^{\circ}C)) / MIN(-40^{\circ}C \text{ to } 85^{\circ}C) / (85^{\circ}C - (-40^{\circ}C))$
- (3) Calculated using the box method: $(MAX(1.8 \text{ V to } 3.6 \text{ V}) - MIN(1.8 \text{ V to } 3.6 \text{ V})) / MIN(1.8 \text{ V to } 3.6 \text{ V}) / (3.6 \text{ V} - 1.8 \text{ V})$

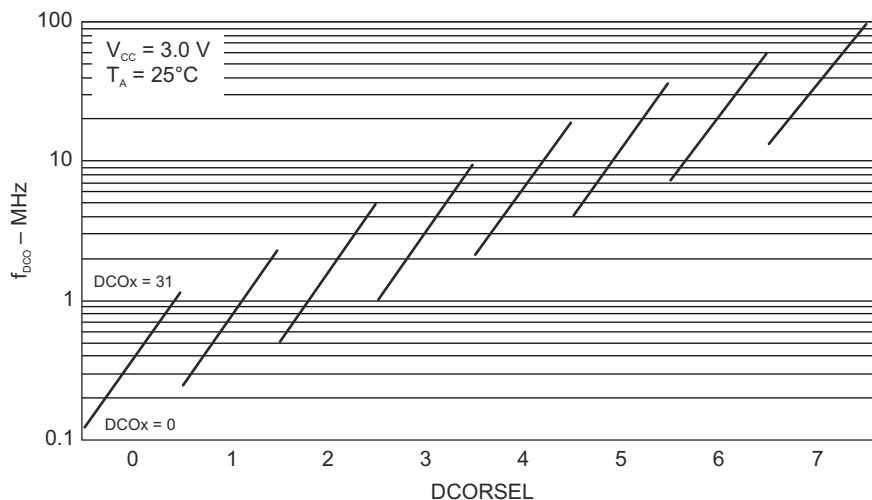

Figure 8-10. Typical DCO Frequency

8.21 PMM, Brownout Reset (BOR)

over recommended ranges of supply voltage and operating free-air temperature (unless otherwise noted)

PARAMETER		TEST CONDITIONS	MIN	TYP	MAX	UNIT
$V_{(DVCC_BOR_IT-)}$	BOR _H on voltage, DV _{CC} falling level	$ dDV_{CC}/dt < 3 \text{ V/s}$			1.45	V
$V_{(DVCC_BOR_IT+)}$	BOR _H off voltage, DV _{CC} rising level	$ dDV_{CC}/dt < 3 \text{ V/s}$	0.80	1.30	1.50	V
$V_{(DVCC_BOR_hys)}$	BOR _H hysteresis		50		250	mV
t_{RESET}	Pulse duration required at RST/NMI pin to accept a reset		2			μs

8.22 PMM, Core Voltage

over recommended ranges of supply voltage and operating free-air temperature (unless otherwise noted)

PARAMETER		TEST CONDITIONS	MIN	TYP	MAX	UNIT
$V_{\text{CORE3(AM)}}$	Core voltage, active mode, PMMCOREV = 3	$2.4 \text{ V} \leq DV_{CC} \leq 3.6 \text{ V}$		1.90		V
$V_{\text{CORE2(AM)}}$	Core voltage, active mode, PMMCOREV = 2	$2.2 \text{ V} \leq DV_{CC} \leq 3.6 \text{ V}$		1.80		V
$V_{\text{CORE1(AM)}}$	Core voltage, active mode, PMMCOREV = 1	$2.0 \text{ V} \leq DV_{CC} \leq 3.6 \text{ V}$		1.60		V
$V_{\text{CORE0(AM)}}$	Core voltage, active mode, PMMCOREV = 0	$1.8 \text{ V} \leq DV_{CC} \leq 3.6 \text{ V}$		1.40		V
$V_{\text{CORE3(LPM)}}$	Core voltage, low-current mode, PMMCOREV = 3	$2.4 \text{ V} \leq DV_{CC} \leq 3.6 \text{ V}$		1.94		V
$V_{\text{CORE2(LPM)}}$	Core voltage, low-current mode, PMMCOREV = 2	$2.2 \text{ V} \leq DV_{CC} \leq 3.6 \text{ V}$		1.84		V
$V_{\text{CORE1(LPM)}}$	Core voltage, low-current mode, PMMCOREV = 1	$2.0 \text{ V} \leq DV_{CC} \leq 3.6 \text{ V}$		1.64		V
$V_{\text{CORE0(LPM)}}$	Core voltage, low-current mode, PMMCOREV = 0	$1.8 \text{ V} \leq DV_{CC} \leq 3.6 \text{ V}$		1.44		V

8.23 PMM, SVS High Side

over recommended ranges of supply voltage and operating free-air temperature (unless otherwise noted)

PARAMETER	TEST CONDITIONS	MIN	TYP	MAX	UNIT
$I_{(SVSH)}$ SVS current consumption	SVSHE = 0, $DV_{CC} = 3.6\text{ V}$		0		nA
	SVSHE = 1, $DV_{CC} = 3.6\text{ V}$, SVSHFP = 0		200		
	SVSHE = 1, $DV_{CC} = 3.6\text{ V}$, SVSHFP = 1		1.5		μA
$V_{(SVSH_IT-)}$ SVS _H on voltage level ⁽¹⁾	SVSHE = 1, SVSHRVL = 0	1.57	1.68	1.78	V
	SVSHE = 1, SVSHRVL = 1	1.79	1.88	1.98	
	SVSHE = 1, SVSHRVL = 2	1.98	2.08	2.21	
	SVSHE = 1, SVSHRVL = 3	2.10	2.18	2.31	
$V_{(SVSH_IT+)}$ SVS _H off voltage level ⁽¹⁾	SVSHE = 1, SVSMHRRL = 0	1.62	1.74	1.85	V
	SVSHE = 1, SVSMHRRL = 1	1.88	1.94	2.07	
	SVSHE = 1, SVSMHRRL = 2	2.07	2.14	2.28	
	SVSHE = 1, SVSMHRRL = 3	2.20	2.30	2.42	
	SVSHE = 1, SVSMHRRL = 4	2.32	2.40	2.55	
	SVSHE = 1, SVSMHRRL = 5	2.52	2.70	2.88	
	SVSHE = 1, SVSMHRRL = 6	2.90	3.10	3.23	
	SVSHE = 1, SVSMHRRL = 7	2.90	3.10	3.23	
$t_{pd(SVSH)}$ SVS _H propagation delay	SVSHE = 1, $dV_{DVCc}/dt = 10\text{ mV}/\mu\text{s}$, SVSHFP = 1		2.5		μs
	SVSHE = 1, $dV_{DVCc}/dt = 1\text{ mV}/\mu\text{s}$, SVSHFP = 0		20		
$t_{(SVSH)}$ SVS _H on or off delay time	SVSHE = 0 → 1, SVSHFP = 1		12.5		μs
	SVSHE = 0 → 1, SVSHFP = 0		100		
dV_{DVCc}/dt DV_{CC} rise time		0		1000	V/s

(1) The SVS_H settings available depend on the VCore (PMMCOREVx) setting. See the *Power Management Module and Supply Voltage Supervisor* chapter in the *MSP430x5xx and MSP430x6xx Family User's Guide* on recommended settings and use.

8.24 PMM, SVM High Side

over recommended ranges of supply voltage and operating free-air temperature (unless otherwise noted)

PARAMETER	TEST CONDITIONS	MIN	TYP	MAX	UNIT
$I_{(SVMH)}$ SVM _H current consumption	SVMHE = 0, $DV_{CC} = 3.6\text{ V}$		0		nA
	SVMHE = 1, $DV_{CC} = 3.6\text{ V}$, SVMHFP = 0		200		
	SVMHE = 1, $DV_{CC} = 3.6\text{ V}$, SVMHFP = 1		1.5		μA
$V_{(SVMH)}$ SVM _H on or off voltage level ⁽¹⁾	SVMHE = 1, SVSMHRRL = 0	1.62	1.74	1.85	V
	SVMHE = 1, SVSMHRRL = 1	1.88	1.94	2.07	
	SVMHE = 1, SVSMHRRL = 2	2.07	2.14	2.28	
	SVMHE = 1, SVSMHRRL = 3	2.20	2.30	2.42	
	SVMHE = 1, SVSMHRRL = 4	2.32	2.40	2.55	
	SVMHE = 1, SVSMHRRL = 5	2.52	2.70	2.88	
	SVMHE = 1, SVSMHRRL = 6	2.90	3.10	3.23	
	SVMHE = 1, SVSMHRRL = 7	2.90	3.10	3.23	
	SVMHE = 1, SVMHOVPE = 1		3.75		
	$t_{pd(SVMH)}$ SVM _H propagation delay	SVMHE = 1, $dV_{DVCc}/dt = 10\text{ mV}/\mu\text{s}$, SVMHFP = 1		2.5	
SVMHE = 1, $dV_{DVCc}/dt = 1\text{ mV}/\mu\text{s}$, SVMHFP = 0			20		
$t_{(SVMH)}$ SVM _H on or off delay time	SVMHE = 0 → 1, SVMHFP = 1		12.5		μs
	SVMHE = 0 → 1, SVMHFP = 0		100		

(1) The SVM_H settings available depend on the VCore (PMMCOREVx) setting. See the *Power Management Module and Supply Voltage Supervisor* chapter in the *MSP430x5xx and MSP430x6xx Family User's Guide* on recommended settings and use.

8.25 PMM, SVS Low Side

over recommended ranges of supply voltage and operating free-air temperature (unless otherwise noted)

PARAMETER		TEST CONDITIONS	MIN	TYP	MAX	UNIT
$I_{(SVSL)}$	SVS _L current consumption	SVSLE = 0, PMMCOREV = 2		0		nA
		SVSLE = 1, PMMCOREV = 2, SVSLFP = 0		200		
		SVSLE = 1, PMMCOREV = 2, SVSLFP = 1		1.5		μA
$t_{pd(SVSL)}$	SVS _L propagation delay	SVSLE = 1, $dV_{CORE}/dt = 10 \text{ mV}/\mu\text{s}$, SVSLFP = 1		2.5		μs
		SVSLE = 1, $dV_{CORE}/dt = 1 \text{ mV}/\mu\text{s}$, SVSLFP = 0		20		
$t_{(SVSL)}$	SVS _L on or off delay time	SVSLE = 0 → 1, $dV_{CORE}/dt = 10 \text{ mV}/\mu\text{s}$, SVSLFP = 1		12.5		μs
		SVSLE = 0 → 1, $dV_{CORE}/dt = 1 \text{ mV}/\mu\text{s}$, SVSLFP = 0		100		

8.26 PMM, SVM Low Side

over recommended ranges of supply voltage and operating free-air temperature (unless otherwise noted)

PARAMETER		TEST CONDITIONS	MIN	TYP	MAX	UNIT
$I_{(SVM_L)}$	SVM _L current consumption	SVMLE = 0, PMMCOREV = 2		0		nA
		SVMLE = 1, PMMCOREV = 2, SVM_LFP = 0		200		
		SVMLE = 1, PMMCOREV = 2, SVM_LFP = 1		1.5		μA
$t_{pd(SVM_L)}$	SVM _L propagation delay	SVMLE = 1, $dV_{CORE}/dt = 10 \text{ mV}/\mu\text{s}$, SVM_LFP = 1		2.5		μs
		SVMLE = 1, $dV_{CORE}/dt = 1 \text{ mV}/\mu\text{s}$, SVM_LFP = 0		20		
$t_{(SVM_L)}$	SVM _L on or off delay time	SVMLE = 0 → 1, $dV_{CORE}/dt = 10 \text{ mV}/\mu\text{s}$, SVM_LFP = 1		12.5		μs
		SVMLE = 0 → 1, $dV_{CORE}/dt = 1 \text{ mV}/\mu\text{s}$, SVM_LFP = 0		100		

8.27 Wake-up Times From Low-Power Modes and Reset

over recommended ranges of supply voltage and operating free-air temperature (unless otherwise noted)

PARAMETER		TEST CONDITIONS	MIN	TYP	MAX	UNIT
$t_{\text{WAKE-UP-FAST}}$	Wake-up time from LPM2, LPM3, or LPM4 to active mode ⁽¹⁾	PMMCOREV = SVSMLRRL = n, $f_{\text{MCLK}} \geq 4.0 \text{ MHz}$ (where n = 0, 1, 2, or 3), SVSLFP = 1		3.5	7.5	μs
		$1.0 \text{ MHz} < f_{\text{MCLK}} < 4.0 \text{ MHz}$		4.5	9	
$t_{\text{WAKE-UP-SLOW}}$	Wake-up time from LPM2, LPM3 or LPM4 to active mode ^{(2) (3)}	PMMCOREV = SVSMLRRL = n (where n = 0, 1, 2, or 3), SVSLFP = 0		150	165	μs
$t_{\text{WAKE-UP-LPM5}}$	Wake-up time from LPM4.5 to active mode ⁽⁴⁾			2	3	ms
$t_{\text{WAKE-UP-RESET}}$	Wake-up time from RST or BOR event to active mode ⁽⁴⁾			2	3	ms

- (1) This value represents the time from the wake-up event to the first active edge of MCLK. The wake-up time depends on the performance mode of the low-side supervisor (SVS_L) and low-side monitor (SVM_L). $t_{\text{WAKE-UP-FAST}}$ is possible with SVS_L and SVM_L in full performance mode or disabled. For specific register settings, see the *Low-Side SVS and SVM Control and Performance Mode Selection* section in the *Power Management Module and Supply Voltage Supervisor* chapter of the [MSP430x5xx and MSP430x6xx Family User's Guide](#).
- (2) This value represents the time from the wake-up event to the first active edge of MCLK. The wake-up time depends on the performance mode of the low-side supervisor (SVS_L) and low-side monitor (SVM_L). $t_{\text{WAKE-UP-SLOW}}$ is set with SVS_L and SVM_L in normal mode (low current mode). For specific register settings, see the *Low-Side SVS and SVM Control and Performance Mode Selection* section in the *Power Management Module and Supply Voltage Supervisor* chapter of the [MSP430x5xx and MSP430x6xx Family User's Guide](#).
- (3) The wake-up times from LPM0 and LPM1 to AM are not specified. They are proportional to MCLK cycle time but are not affected by the performance mode settings as for LPM2, LPM3, and LPM4.
- (4) This value represents the time from the wake-up event to the reset vector execution.

8.28 Timer_A

over recommended ranges of supply voltage and operating free-air temperature (unless otherwise noted)

PARAMETER		TEST CONDITIONS	V _{CC}	MIN	MAX	UNIT
f _{TA}	Timer_A input clock frequency	Internal: SMCLK or ACLK, External: TACLK, Duty cycle = 50% ±10%	1.8 V, 3.0 V		25	MHz
t _{TA,cap}	Timer_A capture timing	All capture inputs, Minimum pulse duration required for capture	1.8 V, 3.0 V	20		ns

8.29 Timer_B

over recommended ranges of supply voltage and operating free-air temperature (unless otherwise noted)

PARAMETER		TEST CONDITIONS	V _{CC}	MIN	MAX	UNIT
f _{TB}	Timer_B input clock frequency	Internal: SMCLK or ACLK, External: TBCLK, Duty cycle = 50% ±10%	1.8 V, 3.0 V		25	MHz
t _{TB,cap}	Timer_B capture timing	All capture inputs, minimum pulse duration required for capture	1.8 V, 3.0 V	20		ns

8.30 USCI (UART Mode) Clock Frequency

PARAMETER		TEST CONDITIONS	MIN	MAX	UNIT
f _{USCI}	USCI input clock frequency	Internal: SMCLK or ACLK, External: UCLK, Duty cycle = 50% ±10%		f _{SYSTEM}	MHz
f _{BITCLK}	BITCLK clock frequency (equals baud rate in MBaud)			1	MHz

8.31 USCI (UART Mode)

over recommended ranges of supply voltage and operating free-air temperature (unless otherwise noted)

PARAMETER		V _{CC}	MIN	MAX	UNIT
t _r	UART receive deglitch time ⁽¹⁾	2.2 V	50	600	ns
		3 V	50	600	

- (1) Pulses on the UART receive input (UCxRX) that are shorter than the UART receive deglitch time are suppressed. To make sure that pulses are correctly recognized, their duration should exceed the maximum specification of the deglitch time.

8.32 USCI (SPI Master Mode) Clock Frequency

PARAMETER		TEST CONDITIONS	MIN	MAX	UNIT
f _{USCI}	USCI input clock frequency	Internal: SMCLK or ACLK, Duty cycle = 50% ±10%		f _{SYSTEM}	MHz

8.33 USCI (SPI Master Mode)

over recommended ranges of supply voltage and operating free-air temperature (unless otherwise noted)⁽¹⁾
(see [Figure 8-11](#) and [Figure 8-12](#))

PARAMETER		TEST CONDITIONS	V _{CC}	MIN	MAX	UNIT
f _{USCI}	USCI input clock frequency	SMCLK or ACLK, Duty cycle = 50% ±10%			f _{SYSTEM}	MHz
t _{SU,MI}	SOMI input data setup time	PMMCOREV = 0	1.8 V	55	ns	
			3.0 V	38		
		PMMCOREV = 3	2.4 V	30		
			3.0 V	25		
t _{HD,MI}	SOMI input data hold time	PMMCOREV = 0	1.8 V	0	ns	
			3.0 V	0		
		PMMCOREV = 3	2.4 V	0		
			3.0 V	0		
t _{VALID,MO}	SIMO output data valid time ⁽²⁾	UCLK edge to SIMO valid, C _L = 20 pF, PMMCOREV = 0	1.8 V	20	ns	
			3.0 V	18		
		UCLK edge to SIMO valid, C _L = 20 pF, PMMCOREV = 3	2.4 V	16		
			3.0 V	15		
t _{HD,MO}	SIMO output data hold time ⁽³⁾	C _L = 20 pF, PMMCOREV = 0	1.8 V	-10	ns	
			3.0 V	-8		
		C _L = 20 pF, PMMCOREV = 3	2.4 V	-10		
			3.0 V	-8		

- (1) $f_{UCxCLK} = 1/2t_{LO/HI}$ with $t_{LO/HI} \geq \max(t_{VALID,MO}(USCI) + t_{SU,SI}(Slave), t_{SU,MI}(USCI) + t_{VALID,SO}(Slave))$
For the slave parameters $t_{SU,SI}(Slave)$ and $t_{VALID,SO}(Slave)$, see the SPI parameters of the attached slave.
- (2) Specifies the time to drive the next valid data to the SIMO output after the output changing UCLK clock edge. See the timing diagrams in [Figure 8-11](#) and [Figure 8-12](#).
- (3) Specifies how long data on the SIMO output is valid after the output changing UCLK clock edge. Negative values indicate that the data on the SIMO output can become invalid before the output changing clock edge observed on UCLK. See the timing diagrams in [Figure 8-11](#) and [Figure 8-12](#).

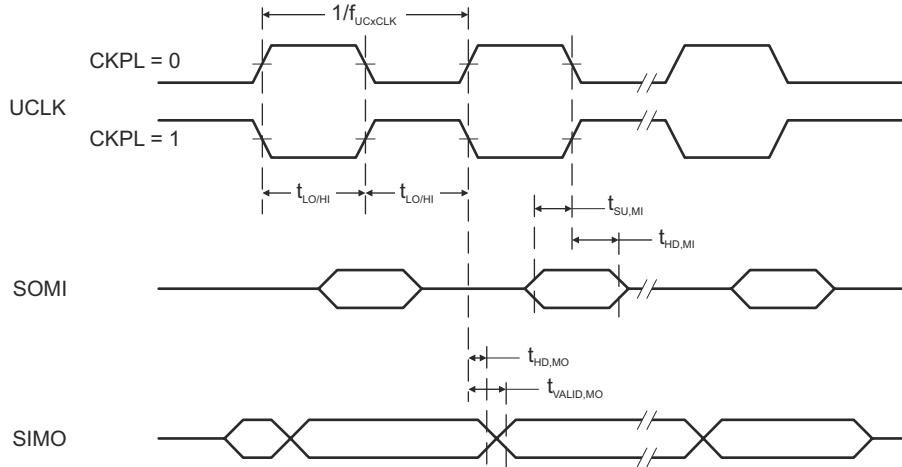

Figure 8-11. SPI Master Mode, CKPH = 0

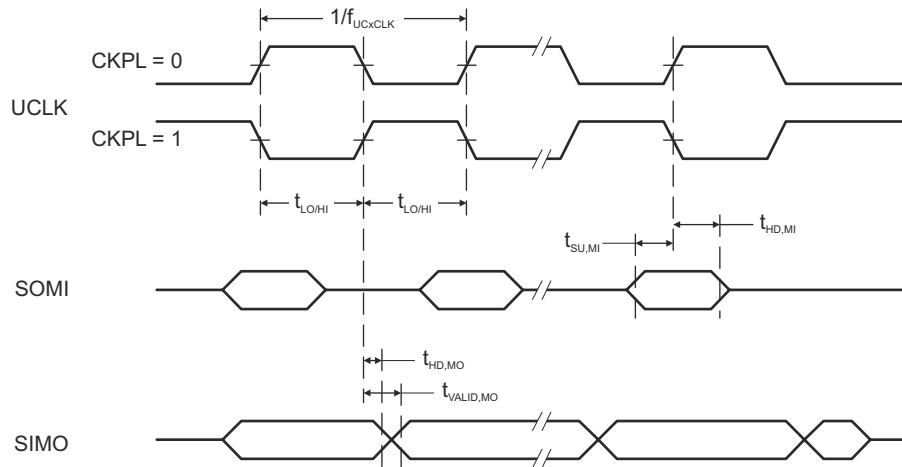

Figure 8-12. SPI Master Mode, CKPH = 1

8.34 USCI (SPI Slave Mode)

over recommended ranges of supply voltage and operating free-air temperature (unless otherwise noted)⁽¹⁾
(see [Figure 8-13](#) and [Figure 8-14](#))

PARAMETER		TEST CONDITIONS	V _{CC}	MIN	MAX	UNIT
t _{STE,LEAD}	STE lead time, STE low to clock	PMMCOREV = 0	1.8 V	11	ns	
			3.0 V	8		
		PMMCOREV = 3	2.4 V	7		
			3.0 V	6		
t _{STE,LAG}	STE lag time, Last clock to STE high	PMMCOREV = 0	1.8 V	3	ns	
			3.0 V	3		
		PMMCOREV = 3	2.4 V	3		
			3.0 V	3		
t _{STE,ACC}	STE access time, STE low to SOMI data out	PMMCOREV = 0	1.8 V	66	ns	
			3.0 V	50		
		PMMCOREV = 3	2.4 V	36		
			3.0 V	30		
t _{STE,DIS}	STE disable time, STE high to SOMI high impedance	PMMCOREV = 0	1.8 V	30	ns	
			3.0 V	23		
		PMMCOREV = 3	2.4 V	16		
			3.0 V	13		
t _{SU,SI}	SIMO input data setup time	PMMCOREV = 0	1.8 V	5	ns	
			3.0 V	5		
		PMMCOREV = 3	2.4 V	2		
			3.0 V	2		
t _{HD,SI}	SIMO input data hold time	PMMCOREV = 0	1.8 V	5	ns	
			3.0 V	5		
		PMMCOREV = 3	2.4 V	5		
			3.0 V	5		
t _{VALID,SO}	SOMI output data valid time ⁽²⁾	UCLK edge to SOMI valid, C _L = 20 pF, PMMCOREV = 0	1.8 V	76	ns	
			3.0 V	60		
		UCLK edge to SOMI valid, C _L = 20 pF, PMMCOREV = 3	2.4 V	44		
			3.0 V	40		
t _{HD,SO}	SOMI output data hold time ⁽³⁾	C _L = 20 pF, PMMCOREV = 0	1.8 V	18	ns	
			3.0 V	12		
		C _L = 20 pF, PMMCOREV = 3	2.4 V	10		
			3.0 V	8		

- (1) $f_{UCxCLK} = 1/2t_{LO/HI}$ with $t_{LO/HI} \geq \max(t_{VALID,MO(Master)} + t_{SU,SI(USCI)}, t_{SU,MI(Master)} + t_{VALID,SO(USCI)})$
For the master parameters $t_{SU,MI(Master)}$ and $t_{VALID,MO(Master)}$, see the SPI parameters of the attached master.
- (2) Specifies the time to drive the next valid data to the SOMI output after the output changing UCLK clock edge. See the timing diagrams in [Figure 8-13](#) and [Figure 8-14](#).
- (3) Specifies how long data on the SOMI output is valid after the output changing UCLK clock edge. See the timing diagrams in [Figure 8-13](#) and [Figure 8-14](#).

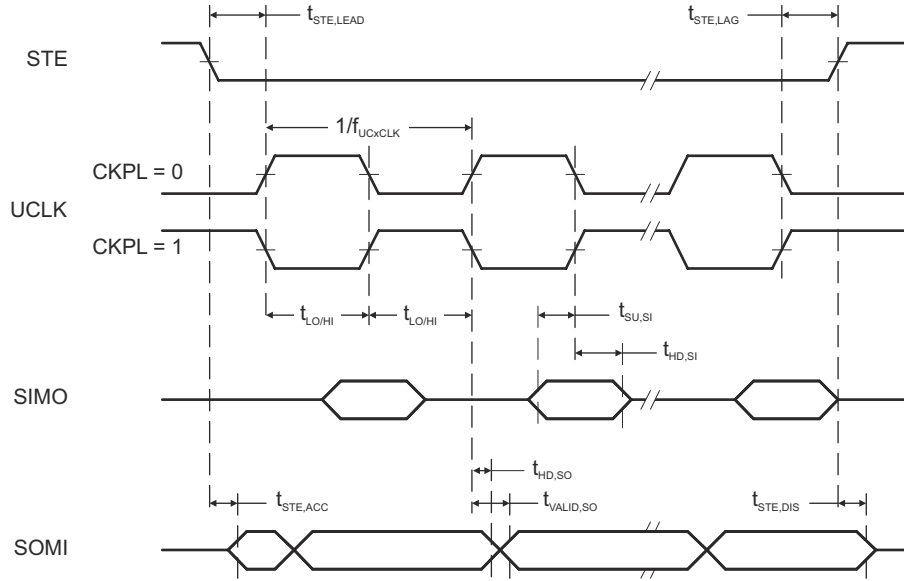

Figure 8-13. SPI Slave Mode, CKPH = 0

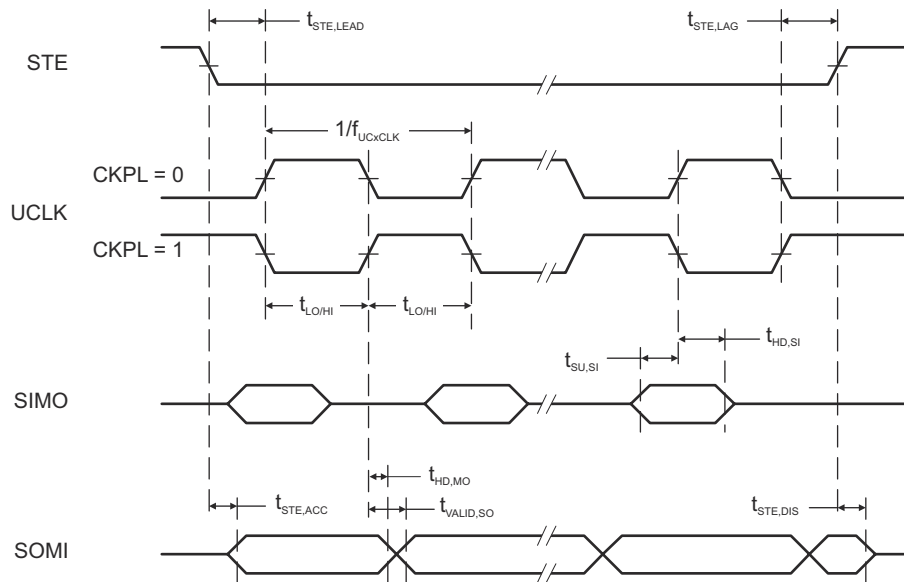

Figure 8-14. SPI Slave Mode, CKPH = 1

8.35 USCI (I²C Mode)

over recommended ranges of supply voltage and operating free-air temperature (unless otherwise noted) (see [Figure 8-15](#))

PARAMETER		TEST CONDITIONS	V _{CC}	MIN	MAX	UNIT
f _{USCI}	USCI input clock frequency	Internal: SMCLK or ACLK, External: UCLK, Duty cycle = 50% ±10%		f _{SYSTEM}		MHz
f _{SCL}	SCL clock frequency		2.2 V, 3 V	0	400	kHz
t _{HD,STA}	Hold time (repeated) START	f _{SCL} ≤ 100 kHz	2.2 V, 3 V	4.0		μs
		f _{SCL} > 100 kHz		0.6		
t _{SU,STA}	Setup time for a repeated START	f _{SCL} ≤ 100 kHz	2.2 V, 3 V	4.7		μs
		f _{SCL} > 100 kHz		0.6		
t _{HD,DAT}	Data hold time		2.2 V, 3 V	0		ns
t _{SU,DAT}	Data setup time		2.2 V, 3 V	250		ns
t _{SU,STO}	Setup time for STOP	f _{SCL} ≤ 100 kHz	2.2 V, 3 V	4.0		μs
		f _{SCL} > 100 kHz		0.6		
t _{SP}	Pulse duration of spikes suppressed by input filter		2.2 V	50	600	ns
			3 V	50	600	

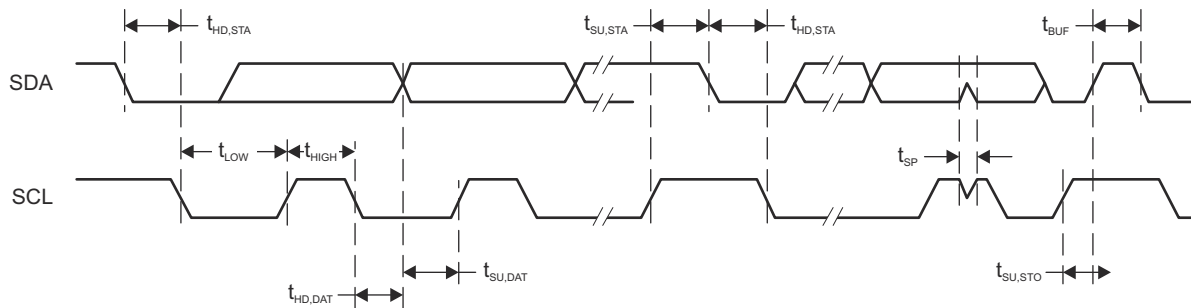

Figure 8-15. I²C Mode Timing

8.36 12-Bit ADC, Power Supply and Input Range Conditions

over recommended ranges of supply voltage and operating free-air temperature (unless otherwise noted)⁽¹⁾

PARAMETER		TEST CONDITIONS	V _{CC}	MIN	TYP	MAX	UNIT
AV _{CC}	Analog supply voltage	AV _{CC} and DV _{CC} are connected together, AV _{SS} and DV _{SS} are connected together, V _(AVSS) = V _(DVSS) = 0 V		2.2		3.6	V
V _(Ax)	Analog input voltage range ⁽²⁾	All ADC12 analog input pins Ax		0		AV _{CC}	V
I _{ADC12_A}	Operating supply current into AV _{CC} terminal ⁽³⁾	f _{ADC12CLK} = 5.0 MHz ⁽⁴⁾	2.2 V		125	155	μA
			3 V		150	220	
C _I	Input capacitance	Only one terminal Ax can be selected at one time	2.2 V		20	25	pF
R _I	Input MUX ON-resistance	0 V ≤ V _{Ax} ≤ AV _{CC}		10	200	1900	Ω

- (1) The leakage current is specified by the digital I/O input leakage.
- (2) The analog input voltage range must be within the selected reference voltage range V_{R+} to V_{R-} for valid conversion results. If the reference voltage is supplied by an external source or if the internal reference voltage is used and REFOUT = 1, then decoupling capacitors are required. See [Section 8.41](#) and [Section 8.42](#).
- (3) The internal reference supply current is not included in current consumption parameter I_{ADC12_A}.
- (4) ADC12ON = 1, REFON = 0, SHT0 = 0, SHT1 = 0, ADC12DIV = 0.

8.37 12-Bit ADC, Timing Parameters

over recommended ranges of supply voltage and operating free-air temperature (unless otherwise noted)

PARAMETER		TEST CONDITIONS	V _{CC}	MIN	TYP	MAX	UNIT
f _{ADC12CLK}	ADC conversion clock	For specified performance of ADC12 linearity parameters using an external reference voltage or AV _{CC} as reference ⁽¹⁾	2.2 V, 3 V	0.45	4.8	5.0	MHz
		For specified performance of ADC12 linearity parameters using the internal reference ⁽²⁾		0.45	2.4	4.0	
		For specified performance of ADC12 linearity parameters using the internal reference ⁽³⁾		0.45	2.4	2.7	
f _{ADC12OSC}	Internal ADC12 oscillator ⁽⁴⁾	ADC12DIV = 0, f _{ADC12CLK} = f _{ADC12OSC}	2.2 V, 3 V	4.2	4.8	5.4	MHz
t _{CONVERT}	Conversion time	REFON = 0, Internal oscillator, ADC12OSC used for ADC conversion clock	2.2 V, 3 V	2.4		3.1	μs
		External f _{ADC12CLK} from ACLK, MCLK, or SMCLK, ADC12SSEL ≠ 0			13 × 1 / f _{ADC12CLK}		
t _{Sample}	Sampling time	R _S = 400 Ω, R _I = 1000 Ω, C _I = 20 pF, τ = (R _S + R _I) × C _I ⁽⁵⁾	2.2 V, 3 V	1000			ns

- (1) REFOUT = 0, external reference voltage: SREF2 = 0, SREF1 = 1, SREF0 = 0. AV_{CC} as reference voltage: SREF2 = 0, SREF1 = 0, SREF0 = 0. The specified performance of the ADC12 linearity is ensured when using the ADC12OSC. For other clock sources, the specified performance of the ADC12 linearity is ensured with f_{ADC12CLK} maximum of 5.0 MHz.
- (2) SREF2 = 0, SREF1 = 1, SREF0 = 0, ADC12SR = 0, REFOUT = 1
- (3) SREF2 = 0, SREF1 = 1, SREF0 = 0, ADC12SR = 0, REFOUT = 0. The specified performance of the ADC12 linearity is ensured when using the ADC12OSC divided by 2.
- (4) The ADC12OSC is sourced directly from MODOSC inside the UCS.
- (5) Approximately 10 Tau (τ) are needed to get an error of less than ±0.5 LSB:
t_{Sample} = ln(2ⁿ⁺¹) × (R_S + R_I) × C_I + 800 ns, where n = ADC resolution = 12, R_S = external source resistance

8.38 12-Bit ADC, Linearity Parameters Using an External Reference Voltage or AVCC as Reference Voltage

over recommended ranges of supply voltage and operating free-air temperature (unless otherwise noted)

PARAMETER		TEST CONDITIONS	V _{CC}	MIN	TYP	MAX	UNIT
E _I	Integral linearity error ⁽¹⁾	1.4 V ≤ dVREF ≤ 1.6 V ⁽²⁾	2.2 V, 3 V			±2.0	LSB
		1.6 V < dVREF ⁽²⁾				±1.7	
E _D	Differential linearity error ⁽¹⁾	⁽²⁾	2.2 V, 3 V			±1.0	LSB
E _O	Offset error ⁽³⁾	dVREF ≤ 2.2 V ⁽²⁾	2.2 V, 3 V		±1.0	±2.0	LSB
		dVREF > 2.2 V ⁽²⁾	2.2 V, 3 V		±1.0	±2.0	
E _G	Gain error ⁽³⁾	⁽²⁾	2.2 V, 3 V		±1.0	±2.0	LSB
E _T	Total unadjusted error	dVREF ≤ 2.2 V ⁽²⁾	2.2 V, 3 V		±1.4	±3.5	LSB
		dVREF > 2.2 V ⁽²⁾	2.2 V, 3 V		±1.4	±3.5	

- (1) Parameters are derived using the histogram method.
- (2) The external reference voltage is selected by: SREF2 = 0 or 1, SREF1 = 1, SREF0 = 0. dVREF = V_{R+} – V_{R-}, V_{R+} < AVCC, V_{R-} > AVSS. Unless otherwise mentioned, dVREF > 1.5 V. Impedance of the external reference voltage R < 100 Ω, and two decoupling capacitors, 10 μF and 100 nF, should be connected to VREF to decouple the dynamic current. See also the [MSP430x6xx Family User's Guide](#).
- (3) Parameters are derived using a best fit curve.

8.39 12-Bit ADC, Linearity Parameters Using the Internal Reference Voltage

over recommended ranges of supply voltage and operating free-air temperature (unless otherwise noted)

PARAMETER		TEST CONDITIONS ⁽¹⁾		V _{CC}	MIN	TYP	MAX	UNIT
E _I	Integral linearity error ⁽²⁾	ADC12SR = 0, REFOUT = 1	f _{ADC12CLK} ≤ 4.0 MHz	2.2 V, 3 V			±1.7	LSB
		ADC12SR = 0, REFOUT = 0	f _{ADC12CLK} ≤ 2.7 MHz				±2.5	
E _D	Differential linearity error ⁽²⁾	ADC12SR = 0, REFOUT = 1	f _{ADC12CLK} ≤ 4.0 MHz	2.2 V, 3 V		-1.0	+1.5	LSB
		ADC12SR = 0, REFOUT = 1	f _{ADC12CLK} ≤ 2.7 MHz			-1.0	+1.0	
		ADC12SR = 0, REFOUT = 0	f _{ADC12CLK} ≤ 2.7 MHz			-1.0	+2.5	
E _O	Offset error ⁽³⁾	ADC12SR = 0, REFOUT = 1	f _{ADC12CLK} ≤ 4.0 MHz	2.2 V, 3 V		±2.0	±4.0	LSB
		ADC12SR = 0, REFOUT = 0	f _{ADC12CLK} ≤ 2.7 MHz			±2.0	±4.0	
E _G	Gain error ⁽³⁾	ADC12SR = 0, REFOUT = 1	f _{ADC12CLK} ≤ 4.0 MHz	2.2 V, 3 V		±1.0	±2.5	LSB
		ADC12SR = 0, REFOUT = 0	f _{ADC12CLK} ≤ 2.7 MHz				±1.5% ⁽⁴⁾	VREF
E _T	Total unadjusted error	ADC12SR = 0, REFOUT = 1	f _{ADC12CLK} ≤ 4.0 MHz	2.2 V, 3 V		±2	±5	LSB
		ADC12SR = 0, REFOUT = 0	f _{ADC12CLK} ≤ 2.7 MHz				±1.5% ⁽⁴⁾	VREF

- (1) The internal reference voltage is selected by: SREF2 = 0 or 1, SREF1 = 1, SREF0 = 1. dVREF = V_{R+} – V_{R-}.
- (2) Parameters are derived using the histogram method.
- (3) Parameters are derived using a best fit curve.
- (4) The gain error and total unadjusted error are dominated by the accuracy of the integrated reference module absolute accuracy. In this mode the reference voltage used by the ADC12_A is not available on a pin.

8.40 12-Bit ADC, Temperature Sensor and Built-In V_{MID}

over recommended ranges of supply voltage and operating free-air temperature (unless otherwise noted)

PARAMETER ⁽¹⁾		TEST CONDITIONS	V_{CC}	MIN	TYP	MAX	UNIT
V_{SENSOR}	See (2)	ADC12ON = 1, INCH = 0Ah, $T_A = 0^\circ\text{C}$	2.2 V	680			mV
			3 V	680			
TC_{SENSOR}		ADC12ON = 1, INCH = 0Ah	2.2 V	2.25			mV/ $^\circ\text{C}$
			3 V	2.25			
$t_{SENSOR(sample)}$	Sample time required if channel 10 is selected ⁽³⁾	ADC12ON = 1, INCH = 0Ah, Error of conversion result ≤ 1 LSB	2.2 V	100			μs
			3 V	100			
V_{MID}	AV _{CC} divider at channel 11, V _{AVCC} factor	ADC12ON = 1, INCH = 0Bh		0.48	0.5	0.52	V _{AVCC}
			2.2 V	1.06	1.1	1.14	V
			3 V	1.44	1.5	1.56	
$t_{VMID(sample)}$	Sample time required if channel 11 is selected ⁽⁴⁾	ADC12ON = 1, INCH = 0Bh, Error of conversion result ≤ 1 LSB	2.2 V, 3 V	1000			ns

- (1) The temperature sensor is provided by the REF module. See the REF module parametric I_{REF+} regarding the current consumption of the temperature sensor.
- (2) The temperature sensor offset can be significant. TI recommends a single-point calibration to minimize the offset error of the built-in temperature sensor. The TLV structure contains calibration values for $30^\circ\text{C} \pm 3^\circ\text{C}$ and $85^\circ\text{C} \pm 3^\circ\text{C}$ for each of the available reference voltage levels. The sensor voltage can be computed as $V_{SENSE} = TC_{SENSOR} \times (\text{Temperature, } ^\circ\text{C}) + V_{SENSOR}$, where TC_{SENSOR} and V_{SENSOR} can be computed from the calibration values for higher accuracy. See also the [MSP430x5xx and MSP430x6xx Family User's Guide](#).
- (3) The typical equivalent impedance of the sensor is 51 k Ω . The sample time required includes the sensor on time, $t_{SENSOR(on)}$.
- (4) The on time ($t_{VMID(on)}$) is included in the sampling time ($t_{VMID(sample)}$); no additional on time is needed.

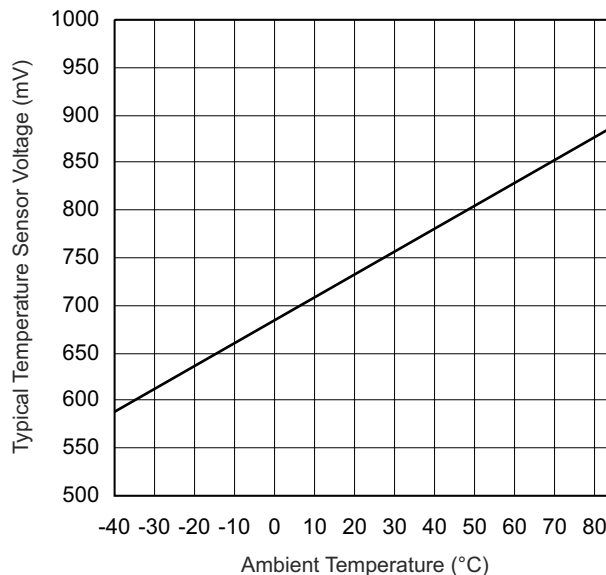

Figure 8-16. Typical Temperature Sensor Voltage

8.41 REF, External Reference

over recommended ranges of supply voltage and operating free-air temperature (unless otherwise noted)⁽¹⁾

PARAMETER		TEST CONDITIONS	V _{CC}	MIN	TYP	MAX	UNIT
V _{eREF+}	Positive external reference voltage input	V _{eREF+} > V _{REF-} /V _{eREF-} ⁽²⁾		1.4		AV _{CC}	V
V _{REF-} /V _{eREF-}	Negative external reference voltage input	V _{eREF+} > V _{REF-} /V _{eREF-} ⁽³⁾		0		1.2	V
(V _{eREF+} – V _{REF-} /V _{eREF-})	Differential external reference voltage input	V _{eREF+} > V _{REF-} /V _{eREF-} ⁽⁴⁾		1.4		AV _{CC}	V
I _{VeREF+} , I _{VREF-/VeREF-}	Static input current	1.4 V ≤ V _{eREF+} ≤ V _{AVCC} , V _{eREF-} = 0 V, f _{ADC12CLK} = 5 MHz, ADC12SHTx = 1h, Conversion rate 200 ksp/s	2.2 V, 3 V	-26		26	μA
		1.4 V ≤ V _{eREF+} ≤ V _{AVCC} , V _{eREF-} = 0 V, f _{ADC12CLK} = 5 MHz, ADC12SHTx = 8h, Conversion rate 20 ksp/s	2.2 V, 3 V	-1		1	
C _{VREF+/-}	Capacitance at VREF+ or VREF- terminals	See ⁽⁵⁾		10			μF

- (1) The external reference is used during ADC conversion to charge and discharge the capacitance array. The input capacitance, C_i, is also the dynamic load for an external reference during conversion. The dynamic impedance of the reference supply should follow the recommendations on analog-source impedance to allow the charge to settle for 12-bit accuracy.
- (2) The accuracy limits the minimum positive external reference voltage. Lower reference voltage levels may be applied with reduced accuracy requirements.
- (3) The accuracy limits the maximum negative external reference voltage. Higher reference voltage levels may be applied with reduced accuracy requirements.
- (4) The accuracy limits minimum external differential reference voltage. Lower differential reference voltage levels may be applied with reduced accuracy requirements.
- (5) Two decoupling capacitors, 10 μF and 100 nF, should be connected to VREF to decouple the dynamic current required for an external reference source if it is used for the ADC12_A. See also the [MSP430x5xx and MSP430x6xx Family User's Guide](#).

8.42 REF, Built-In Reference

over recommended ranges of supply voltage and operating free-air temperature (unless otherwise noted)⁽¹⁾

PARAMETER	TEST CONDITIONS	V _{CC}	MIN	TYP	MAX	UNIT
V _{REF+}	REFVSEL = {2} for 2.5 V, REFON = REFOUT = 1, I _{VREF+} = 0 A	3 V		2.50	±1.5%	V
	REFVSEL = {1} for 2.0 V, REFON = REFOUT = 1, I _{VREF+} = 0 A	3 V		1.98	±1.5%	
	REFVSEL = {0} for 1.5 V, REFON = REFOUT = 1, I _{VREF+} = 0 A	2.2 V, 3 V		1.49	±1.5%	
AV _{CC(min)}	REFVSEL = {0} for 1.5 V			2.2		V
	REFVSEL = {1} for 2.0 V			2.3		
	REFVSEL = {2} for 2.5 V			2.8		
I _{REF+}	ADC12SR = 1, REFON = 1, REFOUT = 0, REFBURST = 0	3 V		70	100	μA
	ADC12SR = 1, REFON = 1, REFOUT = 1, REFBURST = 0	3 V		0.45	0.75	mA
	ADC12SR = 0, REFON = 1, REFOUT = 0, REFBURST = 0	3 V		210	310	μA
	ADC12SR = 0, REFON = 1, REFOUT = 1, REFBURST = 0	3 V		0.95	1.7	mA
I _{L(VREF+)}	REFVSEL = {0, 1, 2} I _{VREF+} = +10 μA or –1000 μA AV _{CC} = AV _{CC(min)} for each reference level, REFVSEL = {0, 1, 2}, REFON = REFOUT = 1				2500	μV/mA
C _{VREF+}	REFON = REFOUT = 1			20	100	pF
TC _{REF+}	I _{VREF+} = 0 A, REFVSEL = {0, 1, 2}, REFON = 1, REFOUT = 0 or 1			30	50	ppm/ °C
PSRR _{DC}	AV _{CC} = AV _{CC(min)} to AV _{CC(max)} , T _A = 25°C, REFVSEL = {0, 1, 2}, REFON = 1, REFOUT = 0 or 1			120	300	μV/V
PSRR _{AC}	AV _{CC} = AV _{CC(min)} to AV _{CC(max)} , T _A = 25°C, f = 1 kHz, ΔV _{pp} = 100 mV, REFVSEL = {0, 1, 2}, REFON = 1, REFOUT = 0 or 1			6.4		mV/V
t _{SETTLE}	AV _{CC} = AV _{CC(min)} to AV _{CC(max)} , REFVSEL = {0, 1, 2}, REFOUT = 0, REFON = 0 → 1			75		μs
	AV _{CC} = AV _{CC(min)} to AV _{CC(max)} , C _{VREF} = C _{VREF(max)} , REFVSEL = {0, 1, 2}, REFOUT = 1, REFON = 0 → 1			75		

- The reference is supplied to the ADC by the REF module and is buffered locally inside the ADC. The ADC uses two internal buffers, one smaller and one larger for driving the VREF+ terminal. When REFOUT = 1, the reference is available at the VREF+ terminal and is used as the reference for the conversion and uses the larger buffer. When REFOUT = 0, the reference is only used as the reference for the conversion and uses the smaller buffer.
- The internal reference current is supplied from the AVCC terminal. Consumption is independent of the ADC12ON control bit, unless a conversion is active. REFOUT = 0 represents the current contribution of the smaller buffer. REFOUT = 1 represents the current contribution of the larger buffer without external load.
- The temperature sensor is provided by the REF module. Its current is supplied from the AVCC terminal and is equivalent to I_{REF+} with REFON = 1 and REFOUT = 0.
- Contribution only due to the reference and buffer including package. This does not include resistance due to the PCB traces or other application factors.
- Calculated using the box method: (MAX(–40°C to 85°C) – MIN(–40°C to 85°C)) / MIN(–40°C to 85°C)/(85°C – (–40°C)).
- The condition is that the error in a conversion started after t_{REFON} is less than ±0.5 LSB. The settling time depends on the external capacitive load when REFOUT = 1.

8.43 Flash Memory

over recommended ranges of supply voltage and operating free-air temperature (unless otherwise noted)

PARAMETER		T _J	MIN	TYP	MAX	UNIT
DV _{CC(PGM/ERASE)}	Program and erase supply voltage		1.8		3.6	V
I _{PGM}	Average supply current from DVCC during program			3	5	mA
I _{ERASE}	Average supply current from DVCC during erase			6	15	mA
I _{MERASE, IBANK}	Average supply current from DVCC during mass erase or bank erase			6	15	mA
t _{CPT}	Cumulative program time ⁽¹⁾				16	ms
	Program and erase endurance		10 ⁴	10 ⁵		cycles
t _{Retention}	Data retention duration	25°C	100			years
t _{Word}	Word or byte program time ⁽²⁾		64		85	µs
t _{Block, 0}	Block program time for first byte or word ⁽²⁾		49		65	µs
t _{Block, 1–(N–1)}	Block program time for each additional byte or word, except for last byte or word ⁽²⁾		37		49	µs
t _{Block, N}	Block program time for last byte or word ⁽²⁾		55		73	µs
t _{Erase}	Erase time for segment, mass erase, and bank erase when available ⁽²⁾		23		32	ms
f _{MCLK,MGR}	MCLK frequency in marginal read mode (FCTL4.MGR0 = 1 or FCTL4.MGR1 = 1)		0		1	MHz

- (1) The cumulative program time must not be exceeded when writing to a 128-byte flash block. This parameter applies to all programming methods: individual word or byte write and block write modes.
- (2) These values are hardwired into the state machine of the flash controller.

8.44 JTAG and Spy-Bi-Wire Interface

over recommended ranges of supply voltage and operating free-air temperature (unless otherwise noted)

PARAMETER		V _{CC}	MIN	TYP	MAX	UNIT
f _{SBW}	Spy-Bi-Wire input frequency	2.2 V, 3 V	0		20	MHz
t _{SBW,Low}	Spy-Bi-Wire low clock pulse duration	2.2 V, 3 V	0.025		15	µs
t _{SBW,En}	Spy-Bi-Wire enable time (TEST high to acceptance of first clock edge) ⁽¹⁾	2.2 V, 3 V			1	µs
t _{SBW,Rst}	Spy-Bi-Wire return to normal operation time		15		100	µs
f _{TCK}	TCK input frequency, 4-wire JTAG ⁽²⁾	2.2 V	0		5	MHz
		3 V	0		10	MHz
R _{internal}	Internal pulldown resistance on TEST	2.2 V, 3 V	45	60	80	kΩ

- (1) Tools that access the Spy-Bi-Wire interface must wait for the t_{SBW,En} time after pulling the TEST/SBWTCK pin high before applying the first SBWTCK clock edge.
- (2) f_{TCK} may be restricted to meet the timing requirements of the module selected.

9 Detailed Description

9.1 CPU

The MSP430 CPU has a 16-bit RISC architecture that is highly transparent to the application. All operations, other than program-flow instructions, are performed as register operations in conjunction with seven addressing modes for source operand and four addressing modes for destination operand.

The CPU is integrated with 16 registers that provide reduced instruction execution time. The register-to-register operation execution time is one cycle of the CPU clock. Four of the registers, R0 to R3, are dedicated as program counter, stack pointer, status register, and constant generator, respectively. The remaining registers are general-purpose registers (see [Figure 9-1](#)).

Peripherals are connected to the CPU using data, address, and control buses. Peripherals can be managed with all instructions.

The instruction set consists of the original 51 instructions with three formats and seven address modes and additional instructions for the expanded address range. Each instruction can operate on word and byte data.

Program Counter	PC/R0
Stack Pointer	SP/R1
Status Register	SR/CG1/R2
Constant Generator	CG2/R3
General-Purpose Register	R4
General-Purpose Register	R5
General-Purpose Register	R6
General-Purpose Register	R7
General-Purpose Register	R8
General-Purpose Register	R9
General-Purpose Register	R10
General-Purpose Register	R11
General-Purpose Register	R12
General-Purpose Register	R13
General-Purpose Register	R14
General-Purpose Register	R15

Figure 9-1. Integrated CPU Registers

9.2 Operating Modes

These microcontrollers have one active mode and six software-selectable low-power modes of operation. An interrupt event can wake up the device from any of the low-power modes, service the request, and restore back to the low-power mode on return from the interrupt program.

Software can configure the following operating modes:

- Active mode (AM)
 - All clocks are active
- Low-power mode 0 (LPM0)
 - CPU is disabled
 - ACLK and SMCLK remain active
 - MCLK is disabled
 - FLL loop control remains active
- Low-power mode 1 (LPM1)
 - CPU is disabled
 - FLL loop control is disabled
 - ACLK and SMCLK remain active
 - MCLK is disabled
- Low-power mode 2 (LPM2)
 - CPU is disabled
 - MCLK, FLL loop control, and DCOCLK are disabled
 - DC generator of the DCO remains enabled
 - ACLK remains active
- Low-power mode 3 (LPM3)
 - CPU is disabled
 - MCLK, FLL loop control, and DCOCLK are disabled
 - DC generator of the DCO is disabled
 - ACLK remains active
- Low-power mode 4 (LPM4)
 - CPU is disabled
 - ACLK is disabled
 - MCLK, FLL loop control, and DCOCLK are disabled
 - DC generator of the DCO is disabled
 - Crystal oscillator is stopped
 - Complete data retention
- Low-power mode 4.5 (LPM4.5)
 - Internal regulator disabled
 - No data retention
 - Wake-up input from $\overline{\text{RST}}$ or digital I/O

9.3 Interrupt Vector Addresses

The interrupt vectors and the power-up start address are in the address range 0FFFFh to 0FF80h (see [Table 9-1](#)). The vector contains the 16-bit address of the appropriate interrupt-handler instruction sequence.

Table 9-1. Interrupt Sources, Flags, and Vectors

INTERRUPT SOURCE	INTERRUPT FLAG	SYSTEM INTERRUPT	WORD ADDRESS	PRIORITY
System Reset Power up External reset Watchdog time-out, password violation Flash memory password violation PMM password violation	WDTIFG, KEYV (SYSRSTIV) ^{(1) (3)}	Reset	0FFFEh	63, highest
System NMI PMM Vacant memory access JTAG mailbox	SVMLIFG, SVMHIFG, DLYLIFG, DLYHIFG, VRLIFG, VLRHIFG, VMAIFG, JMBNIFG, JMBOUTIFG (SYSSNIV) ⁽¹⁾	(Non)maskable	0FFFCh	62
User NMI NMI Oscillator fault Flash memory access violation	NMIIFG, OFIFG, ACCVIFG (SYSUNIV) ^{(1) (3)}	(Non)maskable	0FFFAh	61
TB0	TBCCR0 CCIFG0 ⁽²⁾	Maskable	0FFF8h	60
TB0	TBCCR1 CCIFG1 to TBCCR6 CCIFG6, TBIFG (TBIV) ^{(1) (2)}	Maskable	0FFF6h	59
Watchdog timer interval timer mode	WDTIFG	Maskable	0FFF4h	58
USCI_A0 receive and transmit	UCA0RXIFG, UCA0TXIFG (UCA0IV) ^{(1) (2)}	Maskable	0FFF2h	57
USCI_B0 receive and transmit	UCB0RXIFG, UCB0TXIFG (UCB0IV) ^{(1) (2)}	Maskable	0FFF0h	56
ADC12_A	ADC12IFG0 to ADC12IFG15 (ADC12IV) ^{(1) (2)}	Maskable	0FFEEh	55
TA0	TA0CCR0 CCIFG0 ⁽²⁾	Maskable	0FFECCh	54
TA0	TA0CCR1 CCIFG1 to TA0CCR4 CCIFG4, TA0IFG (TA0IV) ^{(1) (2)}	Maskable	0FFEAh	53
USCI_A2 receive and transmit	UCA2RXIFG, UCA2TXIFG (UCA2IV) ^{(1) (2)}	Maskable	0FFE8h	52
USCI_B2 receive and transmit	UCB2RXIFG, UCB2TXIFG (UCB2IV) ^{(1) (2)}	Maskable	0FFE6h	51
DMA	DMA0IFG, DMA1IFG, DMA2IFG (DMAIV) ^{(1) (2)}	Maskable	0FFE4h	50
TA1	TA1CCR0 CCIFG0 ⁽²⁾	Maskable	0FFE2h	49
TA1	TA1CCR1 CCIFG1 to TA1CCR2 CCIFG2, TA1IFG (TA1IV) ^{(1) (2)}	Maskable	0FFE0h	48
I/O Port P1	P1IFG.0 to P1IFG.7 (P1IV) ^{(1) (2)}	Maskable	0FFDEh	47
USCI_A1 receive and transmit	UCA1RXIFG, UCA1TXIFG (UCA1IV) ^{(1) (2)}	Maskable	0FFDCh	46
USCI_B1 receive and transmit	UCB1RXIFG, UCB1TXIFG (UCB1IV) ^{(1) (2)}	Maskable	0FFDAh	45
USCI_A3 receive and transmit	UCA3RXIFG, UCA3TXIFG (UCA3IV) ^{(1) (2)}	Maskable	0FFD8h	44
USCI_B3 receive and transmit	UCB3RXIFG, UCB3TXIFG (UCB3IV) ^{(1) (2)}	Maskable	0FFD6h	43
I/O Port P2	P2IFG.0 to P2IFG.7 (P2IV) ^{(1) (2)}	Maskable	0FFD4h	42
RTC_A	RTC RDYIFG, RTC TEVIFG, RTC AIFG, RTC PSIFG, RTC 1PSIFG (RTCIV) ^{(1) (2)}	Maskable	0FFD2h	41
Reserved	Reserved ⁽⁴⁾		0FFD0h	40
			⋮	⋮
			0FF80h	0, lowest

- (1) Multiple source flags
- (2) Interrupt flags are in the module.
- (3) A reset is generated if the CPU tries to fetch instructions from within peripheral space or vacant memory space. (Non)maskable: the individual interrupt enable bit can disable an interrupt event, but the general interrupt enable cannot disable it.
- (4) Reserved interrupt vectors at addresses are not used in this device and can be used for regular program code if necessary. To maintain compatibility with other devices, TI recommends reserving these locations.

9.4 Memory Organization

Table 9-2 summarizes the memory map for all devices.

Table 9-2. Memory Organization

		MSP430F5419A MSP430F5418A	MSP430F5436A MSP430F5435A	MSP430F5438A MSP430F5437A
Memory (flash) Main: interrupt vector Main: code memory	Total Size Flash Flash	128KB 00FFFFh to 00FF80h 025BFFh to 005C00h	192KB 00FFFFh to 00FF80h 035BFFh to 005C00h	256KB 00FFFFh to 00FF80h 045BFFh to 005C00h
Main: code memory	Bank D	N/A	23KB 035BFFh to 030000h	64KB 03FFFFh to 030000h
	Bank C	23KB 025BFFh to 020000h	64KB 02FFFFh to 020000h	64KB 02FFFFh to 020000h
	Bank B	64KB 01FFFFh to 010000h	64KB 01FFFFh to 010000h	64KB 01FFFFh to 010000h
	Bank A	41KB 00FFFFh to 005C00h	41KB 00FFFFh to 005C00h	64KB 045BFFh to 040000h 00FFFFh to 005C00h
RAM	Size	16 KB	16KB	16KB
	Sector 3	4KB 005BFFh to 004C00h	4KB 005BFFh to 004C00h	4KB 005BFFh to 004C00h
	Sector 2	4KB 004BFFh to 003C00h	4KB 004BFFh to 003C00h	4KB 004BFFh to 003C00h
	Sector 1	4KB 003BFFh to 002C00h	4KB 003BFFh to 002C00h	4KB 003BFFh to 002C00h
	Sector 0	4KB 002BFFh to 001C00h	4KB 002BFFh to 001C00h	4KB 002BFFh to 001C00h
Information memory (flash)	Info A	128 B 0019FFh to 001980h	128 B 0019FFh to 001980h	128 B 0019FFh to 001980h
	Info B	128 B 00197Fh to 001900h	128 B 00197Fh to 001900h	128 B 00197Fh to 001900h
	Info C	128 B 0018FFh to 001880h	128 B 0018FFh to 001880h	128 B 0018FFh to 001880h
	Info D	128 B 00187Fh to 001800h	128 B 00187Fh to 001800h	128 B 00187Fh to 001800h
Bootloader (BSL) memory (flash)	BSL 3	512 B 0017FFh to 001600h	512 B 0017FFh to 001600h	512 B 0017FFh to 001600h
	BSL 2	512 B 0015FFh to 001400h	512 B 0015FFh to 001400h	512 B 0015FFh to 001400h
	BSL 1	512 B 0013FFh to 001200h	512 B 0013FFh to 001200h	512 B 0013FFh to 001200h
	BSL 0	512 B 0011FFh to 001000h	512 B 0011FFh to 001000h	512 B 0011FFh to 001000h
Peripherals	Size	4KB 000FFFh to 000000h	4KB 000FFFh to 000000h	4KB 000FFFh to 000000h

9.5 Bootloader (BSL)

The BSL enables users to program the flash memory or RAM using a UART serial interface. Access to the device memory through the BSL is protected by a user-defined password. Table 9-3 lists the BSL pin requirements. BSL entry requires a specific entry sequence on the $\overline{\text{RST}}/\text{NMI}/\text{SBWTDIO}$ and $\text{TEST}/\text{SBWTCK}$ pins. For complete description of the features of the BSL and its implementation, see [MSP430 Memory Programming With the Bootloader \(BSL\)](#).

Table 9-3. BSL Pin Requirements and Functions

DEVICE SIGNAL	BSL FUNCTION
RST/NMI/SBWDIO	Entry sequence signal
TEST/SBWTCK	Entry sequence signal
P1.1	Data transmit
P1.2	Data receive
VCC	Power supply
VSS	Ground supply

9.6 JTAG Operation

9.6.1 JTAG Standard Interface

The MSP430 family supports the standard JTAG interface which requires four signals for sending and receiving data. The JTAG signals are shared with general-purpose I/O. The TEST/SBWTCK pin is used to enable the JTAG signals. In addition to these signals, the RST/NMI/SBWDIO is required to interface with MSP430 development tools and device programmers. [Table 9-4](#) lists the JTAG pin requirements. For further details on interfacing to development tools and device programmers, see the [MSP430 Hardware Tools User's Guide](#). For complete description of the features of the JTAG interface and its implementation, see [MSP430 Memory Programming With the JTAG Interface](#).

Table 9-4. JTAG Pin Requirements and Functions

DEVICE SIGNAL	DIRECTION	FUNCTION
PJ.3/TCK	IN	JTAG clock input
PJ.2/TMS	IN	JTAG state control
PJ.1/TDI/TCLK	IN	JTAG data input, TCLK input
PJ.0/TDO	OUT	JTAG data output
TEST/SBWTCK	IN	Enable JTAG pins
RST/NMI/SBWDIO	IN	External reset
VCC		Power supply
VSS		Ground supply

9.6.2 Spy-Bi-Wire Interface

In addition to the standard JTAG interface, the MSP430 microcontrollers support the 2-wire Spy-Bi-Wire interface. Spy-Bi-Wire can be used to interface with MSP430 development tools and device programmers. [Table 9-5](#) lists the Spy-Bi-Wire interface pin requirements. For further details on interfacing to development tools and device programmers, see the [MSP430 Hardware Tools User's Guide](#). For the description of the Spy-Bi-Wire interface and its implementation, see the [MSP430 Memory Programming With the JTAG Interface](#).

Table 9-5. Spy-Bi-Wire Pin Requirements and Functions

DEVICE SIGNAL	DIRECTION	FUNCTION
TEST/SBWTCK	IN	Spy-Bi-Wire clock input
RST/NMI/SBWDIO	IN, OUT	Spy-Bi-Wire data input and output
VCC		Power supply
VSS		Ground supply

9.7 Flash Memory

The flash memory can be programmed through the JTAG port, Spy-Bi-Wire (SBW), the BSL, or in-system by the CPU. The CPU can perform single-byte, single-word, and long-word writes to the flash memory. Features of the flash memory include:

- Flash memory has n segments of main memory and four segments of information memory (A to D) of 128 bytes each. Each segment in main memory is 512 bytes in size.
- Segments 0 to n may be erased in one step, or each segment may be individually erased.
- Segments A to D can be erased individually. Segments A to D are also called *information memory*.
- Segment A can be locked separately.

9.8 RAM

The RAM is made up of n sectors. Each sector can be completely powered down to save leakage; however, all data are lost. Features of the RAM include:

- RAM has n sectors. The size of a sector can be found in [Section 9.4](#).
- Each sector 0 to n can be completely disabled; however, data retention is lost.
- Each sector 0 to n automatically enters low-power retention mode when possible.
- For devices that contain USB memory, the USB memory can be used as normal RAM if USB is not required.

9.9 Peripherals

Peripherals are connected to the CPU through data, address, and control buses. Peripherals can be handled using all instructions. For complete module descriptions, see the [MSP430x5xx and MSP430x6xx Family User's Guide](#).

9.9.1 Digital I/O

Up to ten 8-bit I/O ports are implemented: For 100- and 113-pin options, P1 through P10 are complete, and P11 contains three individual I/O ports. For 80-pin options, P1 through P7 are complete, P8 contains seven individual I/O ports, and P9 through P11 do not exist. Port PJ contains four individual I/O ports, common to all devices.

- All individual I/O bits are independently programmable.
- Any combination of input, output, and interrupt conditions is possible.
- Pullup or pulldown on all ports is programmable.
- Drive strength on all ports is programmable.
- Edge-selectable interrupt and LPM4.5 wake-up input capability is available for all bits of ports P1 and P2.
- Read and write access to port-control registers is supported by all instructions.
- Ports can be accessed byte-wise (P1 through P11) or word-wise in pairs (PA through PF).

9.9.2 Oscillator and System Clock

The clock system is supported by the Unified Clock System (UCS) module that includes support for a 32-kHz watch crystal oscillator (XT1 LF mode), an internal very-low-power low-frequency oscillator (VLO), an internal trimmed low-frequency oscillator (REFO), an integrated internal digitally controlled oscillator (DCO), and a high-frequency crystal oscillator (XT1 HF mode or XT2). The UCS module is designed to meet the requirements of both low system cost and low power consumption. The UCS module features digital frequency locked loop (FLL) hardware that, in conjunction with a digital modulator, stabilizes the DCO frequency to a programmable multiple of the selected FLL reference frequency. The internal DCO provides a fast turnon clock source and stabilizes in less than 5 μ s. The UCS module provides the following clock signals:

- Auxiliary clock (ACLK), sourced from a 32-kHz watch crystal, a high-frequency crystal, the internal low-frequency oscillator (VLO), the trimmed low-frequency oscillator (REFO), or the internal digitally controlled oscillator (DCO).
- Main clock (MCLK), the system clock used by the CPU. MCLK can be sourced by same sources made available to ACLK.
- Sub-Main clock (SMCLK), the subsystem clock used by the peripheral modules. SMCLK can be sourced by same sources made available to ACLK.
- ACLK/n, the buffered output of ACLK, ACLK/2, ACLK/4, ACLK/8, ACLK/16, ACLK/32.

9.9.3 Power-Management Module (PMM)

The PMM includes an integrated voltage regulator that supplies the core voltage to the device and contains programmable output levels to provide for power optimization. The PMM also includes supply voltage supervisor (SVS) and supply voltage monitoring (SVM) circuitry, as well as brownout protection. The brownout circuit is implemented to provide the proper internal reset signal to the device during power on and power off. The SVS and SVM circuitry detects if the supply voltage drops below a user-selectable level and supports both supply voltage supervision (the device is automatically reset) and supply voltage monitoring (the device is not automatically reset). SVS and SVM circuitry is available on the primary supply and core supply.

9.9.4 Hardware Multiplier (MPY)

The multiplication operation is supported by a dedicated peripheral module. The module performs operations with 32-, 24-, 16-, and 8-bit operands. The module supports signed and unsigned multiplication as well as signed and unsigned multiply-and-accumulate operations.

9.9.5 Real-Time Clock (RTC_A)

The RTC_A module can be used as a general-purpose 32-bit counter (counter mode) or as an integrated real-time clock (calendar mode). In counter mode, the RTC_A also includes two independent 8-bit timers that can be cascaded to form a 16-bit timer/counter. Both timers can be read and written by software. Calendar mode integrates an internal calendar which compensates for months with less than 31 days and includes leap year correction. The RTC_A also supports flexible alarm functions and offset-calibration hardware.

9.9.6 Watchdog Timer (WDT_A)

The primary function of the WDT_A module is to perform a controlled system restart after a software problem occurs. If the selected time interval expires, a system reset is generated. If the watchdog function is not needed in an application, the module can be configured as an interval timer and can generate interrupts at selected time intervals.

9.9.7 System Module (SYS)

The SYS module handles many of the system functions within the device. These functions include power on reset and power up clear handling, NMI source selection and management, reset interrupt vector generators, bootloader entry mechanisms, and configuration management (device descriptors). SYS also includes a data exchange mechanism through JTAG called a JTAG mailbox that can be used in the application. [Table 9-6](#) summarizes the SYS module interrupt vector registers.

Table 9-6. System Module Interrupt Vector Registers

INTERRUPT VECTOR REGISTER	ADDRESS	INTERRUPT EVENT	VALUE	PRIORITY
SYSRSTIV, System Reset	019Eh	No interrupt pending	00h	
		Brownout (BOR)	02h	Highest
		RST/NMI (POR)	04h	
		PMMSWBOR (BOR)	06h	
		Wake up from LPMx.5	08h	
		Security violation (BOR)	0Ah	
		SVSL (POR)	0Ch	
		SVSH (POR)	0Eh	
		SVML_OVP (POR)	10h	
		SVMH_OVP (POR)	12h	
		PMMSWPOR (POR)	14h	
		WDT time-out (PUC)	16h	
		WDT password violation (PUC)	18h	
		KEYV flash password violation (PUC)	1Ah	
		Reserved	1Ch	
		Peripheral area fetch (PUC)	1Eh	
		PMM password violation (PUC)	20h	
Reserved	22h to 3Eh	Lowest		
SYSSNIV, System NMI	019Ch	No interrupt pending	00h	
		SVMLIFG	02h	Highest
		SVMHIFG	04h	
		SVSMLDLYIFG	06h	
		SVSMHDLYIFG	08h	
		VMAIFG	0Ah	
		JMBINIFG	0Ch	
		JMBOUTIFG	0Eh	
		SVMLVLRIFG	10h	
		SVMHVLRFIFG	12h	
		Reserved	14h to 1Eh	Lowest
		SYSUNIV, User NMI	019Ah	No interrupt pending
NMIIFG	02h			Highest
OFIFG	04h			
ACCVIFG	06h			
Reserved	08h			
Reserved	0Ah to 1Eh			Lowest

9.9.8 DMA Controller

The DMA controller allows movement of data from one memory address to another without CPU intervention. For example, the DMA controller can be used to move data from the ADC12_A conversion memory to RAM. Using the DMA controller can increase the throughput of peripheral modules. The DMA controller reduces system power consumption by allowing the CPU to remain in sleep mode, without having to awaken to move data to or from a peripheral. [Table 9-7](#) lists the available DMA triggers.

Table 9-7. DMA Trigger Assignments

TRIGGER ⁽¹⁾	CHANNEL		
	0	1	2
0	DMAREQ	DMAREQ	DMAREQ
1	TA0CCR0 CCIFG	TA0CCR0 CCIFG	TA0CCR0 CCIFG
2	TA0CCR2 CCIFG	TA0CCR2 CCIFG	TA0CCR2 CCIFG
3	TA1CCR0 CCIFG	TA1CCR0 CCIFG	TA1CCR0 CCIFG
4	TA1CCR2 CCIFG	TA1CCR2 CCIFG	TA1CCR2 CCIFG
5	TB0CCR0 CCIFG	TB0CCR0 CCIFG	TB0CCR0 CCIFG
6	TB0CCR2 CCIFG	TB0CCR2 CCIFG	TB0CCR2 CCIFG
7	Reserved	Reserved	Reserved
8	Reserved	Reserved	Reserved
9	Reserved	Reserved	Reserved
10	Reserved	Reserved	Reserved
11	Reserved	Reserved	Reserved
12	Reserved	Reserved	Reserved
13	Reserved	Reserved	Reserved
14	Reserved	Reserved	Reserved
15	Reserved	Reserved	Reserved
16	UCA0RXIFG	UCA0RXIFG	UCA0RXIFG
17	UCA0TXIFG	UCA0TXIFG	UCA0TXIFG
18	UCB0RXIFG	UCB0RXIFG	UCB0RXIFG
19	UCB0TXIFG	UCB0TXIFG	UCB0TXIFG
20	UCA1RXIFG	UCA1RXIFG	UCA1RXIFG
21	UCA1TXIFG	UCA1TXIFG	UCA1TXIFG
22	UCB1RXIFG	UCB1RXIFG	UCB1RXIFG
23	UCB1TXIFG	UCB1TXIFG	UCB1TXIFG
24	ADC12IFGx	ADC12IFGx	ADC12IFGx
25	Reserved	Reserved	Reserved
26	Reserved	Reserved	Reserved
27	Reserved	Reserved	Reserved
28	Reserved	Reserved	Reserved
29	MPY ready	MPY ready	MPY ready
30	DMA2IFG	DMA0IFG	DMA1IFG
31	DMAE0	DMAE0	DMAE0

(1) Reserved DMA triggers may be used by other devices in the family. Reserved DMA triggers do not cause any DMA trigger event when selected.

9.9.9 Universal Serial Communication Interface (USCI)

The USCI modules are used for serial data communication. The USCI module supports synchronous communication protocols such as SPI (3-pin or 4-pin) and I²C, and asynchronous communication protocols such as UART, enhanced UART with automatic baud-rate detection, and IrDA. Each USCI module contains two portions, A and B.

The USCI_An module provides support for SPI (3-pin or 4-pin), UART, enhanced UART, or IrDA.

The USCI_Bn module provides support for SPI (3-pin or 4-pin) or I²C.

The MSP430F5438A, MSP430F5436A, and MSP430F5419A include four complete USCI modules (n = 0 to 3). The MSP430F5437A, MSP430F5435A, and MSP430F5418A include two complete USCI modules (n = 0 or 1).

9.9.10 TAO

TA0 is a 16-bit timer/counter (Timer_A type) with five capture/compare registers. TA0 can support multiple capture/compares, PWM outputs, and interval timing (see Table 9-8). TA0 also has extensive interrupt capabilities. Interrupts may be generated from the counter on overflow conditions and from each of the capture/compare registers. Table 9-8 lists the available signal connections.

Table 9-8. TAO Signal Connections

INPUT PIN NUMBER		DEVICE INPUT SIGNAL	MODULE INPUT SIGNAL	MODULE BLOCK	MODULE OUTPUT SIGNAL	DEVICE OUTPUT SIGNAL	OUTPUT PIN NUMBER	
PZ, ZCA, ZQW	PN						PZ, ZCA, ZQW	PN
17, H1-P1.0	17-P1.0	TA0CLK	TACLK	Timer	N/A	N/A		
		ACLK	ACLK					
		SMCLK	SMCLK					
17, H1-P1.0	17-P1.0	TA0CLK	\overline{TACLK}					
18, H4-P1.1	18-P1.1	TA0.0	CCI0A	CCR0	TA0	TA0.0	18, H4-P1.1	18-P1.1
57, H9-P8.0	60-P8.0	TA0.0	CCI0B				57, H9-P8.0	60-P8.0
		DV _{SS}	GND				ADC12 (internal) ADC12SHSx = {1}	ADC12 (internal) ADC12SHSx = {1}
		DV _{CC}	V _{CC}					
19, J4-P1.2	19-P1.2	TA0.1	CCI1A	CCR1	TA1	TA0.1	19, J4-P1.2	19-P1.2
58, H11-P8.1	61-P8.1	TA0.1	CCI1B				58, H11-P8.1	61-P8.1
		DV _{SS}	GND					
		DV _{CC}	V _{CC}					
20, J1-P1.3	20-P1.3	TA0.2	CCI2A	CCR2	TA2	TA0.2	20, J1-P1.3	20-P1.3
59, H12-P8.2	62-P8.2	TA0.2	CCI2B				59, H12-P8.2	62-P8.2
		DV _{SS}	GND					
		DV _{CC}	V _{CC}					
21, J2-P1.4	21-P1.4	TA0.3	CCI3A	CCR3	TA3	TA0.3	21, J2-P1.4	21-P1.4
60, G9-P8.3	63-P8.3	TA0.3	CCI3B				60, G9-P8.3	63-P8.3
		DV _{SS}	GND					
		DV _{CC}	V _{CC}					
22, K1-P1.5	22-P1.5	TA0.4	CCI4A	CCR4	TA4	TA0.4	22, K1-P1.5	22-P1.5
61, G11-P8.4	64-P8.4	TA0.4	CCI4B				61, G11-P8.4	64-P8.4
		DV _{SS}	GND					
		DV _{CC}	V _{CC}					

9.9.11 TA1

TA1 is a 16-bit timer/counter (Timer_A type) with three capture/compare registers. TA1 can support multiple capture/comparers, PWM outputs, and interval timing (see [Table 9-9](#)). TA1 also has extensive interrupt capabilities. Interrupts may be generated from the counter on overflow conditions and from each of the capture/compare registers. [Table 9-9](#) lists the available signal connections.

Table 9-9. TA1 Signal Connections

INPUT PIN NUMBER		DEVICE INPUT SIGNAL	MODULE INPUT SIGNAL	MODULE BLOCK	MODULE OUTPUT SIGNAL	DEVICE OUTPUT SIGNAL	OUTPUT PIN NUMBER	
PZ, ZCA, ZQW	PN						PZ, ZCA, ZQW	PN
25, M1-P2.0	25-P2.0	TA1CLK	TACLK	Timer	N/A	N/A		
		ACLK	ACLK					
		SMCLK	SMCLK					
25, M1-P2.0	25-P2.0	TA1CLK	$\overline{\text{TACLK}}$					
26, L2-P2.1	26-P2.1	TA1.0	CCI0A	CCR0	TA0	TA1.0	26, L2-P2.1	26-P2.1
65, F11-P8.5	65-P8.5	TA1.0	CCI0B				65, F11-P8.5	65-P8.5
		DV _{SS}	GND					
		DV _{CC}	V _{CC}					
27, M2-P2.2	27-P2.2	TA1.1	CCI1A	CCR1	TA1	TA1.1	27, M2-P2.2	27-P2.2
66, E11-P8.6	66-P8.6	TA1.1	CCI1B				66, E11-P8.6	66-P8.6
		DV _{SS}	GND					
		DV _{CC}	V _{CC}					
28, L3-P2.3	28-P2.3	TA1.2	CCI2A	CCR2	TA2	TA1.2	28, L3-P2.3	28-P2.3
56, J12-P7.3	59-P7.3	TA1.2	CCI2B				56, J12-P7.3	59-P7.3
		DV _{SS}	GND					
		DV _{CC}	V _{CC}					

9.9.12 TB0

TB0 is a 16-bit timer/counter (Timer_B type) with seven capture/compare registers. TB0 can support multiple capture/compares, PWM outputs, and interval timing (see [Table 9-10](#)). TB0 also has extensive interrupt capabilities. Interrupts may be generated from the counter on overflow conditions and from each of the capture/compare registers. [Table 9-10](#) lists the available signal connections.

Table 9-10. TB0 Signal Connections

INPUT PIN NUMBER		DEVICE INPUT SIGNAL	MODULE INPUT SIGNAL	MODULE BLOCK	MODULE OUTPUT SIGNAL	DEVICE OUTPUT SIGNAL	OUTPUT PIN NUMBER	
PZ, ZCA, ZQW	PN						PZ, ZCA, ZQW	PN
50, M12-P4.7	53-P4.7	TB0CLK	TBCLK	Timer	N/A	N/A		
		ACLK	ACLK					
		SMCLK	SMCLK					
50, M12-P4.7	53-P4.7	TB0CLK	TBCLK					
43, J8-P4.0	43-P4.0	TB0.0	CCI0A	CCR0	TB0	TB0.0	43, J8-P4.0	43-P4.0
43, J8-P4.0	43-P4.0	TB0.0	CCI0B				ADC12 (internal) ADC12SHSx = {2}	ADC12 (internal) ADC12SHSx = {2}
		DV _{SS}	GND					
		DV _{CC}	V _{CC}					
44, M9-P4.1	44-P4.1	TB0.1	CCI1A	CCR1	TB1	TB0.1	44, M9-P4.1	44-P4.1
44, M9-P4.1	44-P4.1	TB0.1	CCI1B				ADC12 (internal) ADC12SHSx = {3}	ADC12 (internal) ADC12SHSx = {3}
		DV _{SS}	GND					
		DV _{CC}	V _{CC}					
45, L9-P4.2	45-P4.2	TB0.2	CCI2A	CCR2	TB2	TB0.2	45, L9-P4.2	45-P4.2
45, L9-P4.2	45-P4.2	TB0.2	CCI2B					
		DV _{SS}	GND					
		DV _{CC}	V _{CC}					
46, L10-P4.3	46-P4.3	TB0.3	CCI3A	CCR3	TB3	TB0.3	46, L10-P4.3	46-P4.3
46, L10-P4.3	46-P4.3	TB0.3	CCI3B					
		DV _{SS}	GND					
		DV _{CC}	V _{CC}					
47, M10-P4.4	47-P4.4	TB0.4	CCI4A	CCR4	TB4	TB0.4	47, M10-P4.4	47-P4.4
47, M10-P4.4	47-P4.4	TB0.4	CCI4B					
		DV _{SS}	GND					
		DV _{CC}	V _{CC}					
48, L11-P4.5	48-P4.5	TB0.5	CCI5A	CCR5	TB5	TB0.5	48, L11-P4.5	48-P4.5
48, L11-P4.5	48-P4.5	TB0.5	CCI5B					
		DV _{SS}	GND					
		DV _{CC}	V _{CC}					
49, M11-P4.6	52-P4.6	TB0.6	CCI6A	CCR6	TB6	TB0.6	49, M11-P4.6	52-P4.6
		ACLK (internal)	CCI6B					
		DV _{SS}	GND					
		DV _{CC}	V _{CC}					

9.9.13 ADC12_A

The ADC12_A module supports fast 12-bit analog-to-digital conversions. The module implements a 12-bit SAR core, sample select control, reference generator, and a 16-word conversion-and-control buffer. The conversion-and-control buffer allows up to 16 independent ADC samples to be converted and stored without any CPU intervention.

9.9.14 CRC16

The CRC16 module produces a signature based on a sequence of entered data values and can be used for data checking purposes. The CRC16 module signature is based on the CRC-CCITT standard.

9.9.15 Reference (REF) Module Voltage Reference

The REF is responsible for generation of all critical reference voltages that can be used by the various analog peripherals in the device.

9.9.16 Embedded Emulation Module (EEM) (L Version)

The EEM supports real-time in-system debugging. The L version of the EEM has the following features:

- Eight hardware triggers or breakpoints on memory access
- Two hardware trigger or breakpoint on CPU register write access
- Up to 10 hardware triggers that can be combined to form complex triggers or breakpoints
- Two cycle counters
- Sequencer
- State storage
- Clock control on module level

9.9.17 Peripheral File Map

Table 9-11 lists the base address of the registers for each peripheral.

Table 9-11. Peripherals

MODULE NAME	BASE ADDRESS	OFFSET ADDRESS RANGE
Special Functions (see Table 9-12)	0100h	000h to 01Fh
PMM (see Table 9-13)	0120h	000h to 010h
Flash Control (see Table 9-14)	0140h	000h to 00Fh
CRC16 (see Table 9-15)	0150h	000h to 007h
RAM Control (see Table 9-16)	0158h	000h to 001h
Watchdog (see Table 9-17)	015Ch	000h to 001h
UCS (see Table 9-18)	0160h	000h to 01Fh
SYS (see Table 9-19)	0180h	000h to 01Fh
Shared Reference (see Table 9-20)	01B0h	000h to 001h
Port P1, P2 (see Table 9-21)	0200h	000h to 01Fh
Port P3, P4 (see Table 9-22)	0220h	000h to 00Bh
Port P5, P6 (see Table 9-23)	0240h	000h to 00Bh
Port P7, P8 (see Table 9-24)	0260h	000h to 00Bh
Port P9, P10 (see Table 9-25)	0280h	000h to 00Bh
Port P11 (see Table 9-26)	02A0h	000h to 00Ah
Port PJ (see Table 9-27)	0320h	000h to 01Fh
TA0 (see Table 9-28)	0340h	000h to 02Eh
TA1 (see Table 9-29)	0380h	000h to 02Eh
TB0 (see Table 9-30)	03C0h	000h to 02Eh
Real Timer Clock (RTC_A) (see Table 9-31)	04A0h	000h to 01Bh
32-Bit Hardware Multiplier (see Table 9-32)	04C0h	000h to 02Fh
DMA General Control (see Table 9-33)	0500h	000h to 00Fh
DMA Channel 0 (see Table 9-33)	0510h	000h to 00Ah
DMA Channel 1 (see Table 9-33)	0520h	000h to 00Ah
DMA Channel 2 (see Table 9-33)	0530h	000h to 00Ah
USCI_A0 (see Table 9-34)	05C0h	000h to 01Fh
USCI_B0 (see Table 9-35)	05E0h	000h to 01Fh
USCI_A1 (see Table 9-36)	0600h	000h to 01Fh
USCI_B1 (see Table 9-37)	0620h	000h to 01Fh
USCI_A2 (see Table 9-38)	0640h	000h to 01Fh
USCI_B2 (see Table 9-39)	0660h	000h to 01Fh
USCI_A3 (see Table 9-40)	0680h	000h to 01Fh
USCI_B3 (see Table 9-41)	06A0h	000h to 01Fh
ADC12_A (see Table 9-42)	0700h	000h to 03Eh

Table 9-12. Special Function Registers (Base Address: 0100h)

REGISTER DESCRIPTION	REGISTER	OFFSET
SFR interrupt enable	SFRIE1	00h
SFR interrupt flag	SFRIFG1	02h
SFR reset pin control	SFRRPCR	04h

Table 9-13. PMM Registers (Base Address: 0120h)

REGISTER DESCRIPTION	REGISTER	OFFSET
PMM control 0	PMMCTL0	00h
PMM control 1	PMMCTL1	02h
SVS high-side control	SVSMHCTL	04h
SVS low-side control	SVSMLCTL	06h
PMM interrupt flags	PMMIFG	0Ch
PMM interrupt enable	PMMIE	0Eh
PMM power mode 5 control	PM5CTL0	10h

Table 9-14. Flash Control Registers (Base Address: 0140h)

REGISTER DESCRIPTION	REGISTER	OFFSET
Flash control 1	FCTL1	00h
Flash control 3	FCTL3	04h
Flash control 4	FCTL4	06h

Table 9-15. CRC16 Registers (Base Address: 0150h)

REGISTER DESCRIPTION	REGISTER	OFFSET
CRC data input	CRC16DI	00h
CRC data input reverse byte	CRCDIRB	02h
CRC initialization and result	CRCINIRES	04h
CRC result reverse byte	CRCRESR	06h

Table 9-16. RAM Control Registers (Base Address: 0158h)

REGISTER DESCRIPTION	REGISTER	OFFSET
RAM control 0	RCCTL0	00h

Table 9-17. Watchdog Registers (Base Address: 015Ch)

REGISTER DESCRIPTION	REGISTER	OFFSET
Watchdog timer control	WDTCTL	00h

Table 9-18. UCS Registers (Base Address: 0160h)

REGISTER DESCRIPTION	REGISTER	OFFSET
UCS control 0	UCSCTL0	00h
UCS control 1	UCSCTL1	02h
UCS control 2	UCSCTL2	04h
UCS control 3	UCSCTL3	06h
UCS control 4	UCSCTL4	08h
UCS control 5	UCSCTL5	0Ah
UCS control 6	UCSCTL6	0Ch
UCS control 7	UCSCTL7	0Eh
UCS control 8	UCSCTL8	10h

Table 9-19. SYS Registers (Base Address: 0180h)

REGISTER DESCRIPTION	REGISTER	OFFSET
System control	SYSCTL	00h
Bootloader configuration area	SYSBSLC	02h
JTAG mailbox control	SYSJMBC	06h
JTAG mailbox input 0	SYSJMBI0	08h
JTAG mailbox input 1	SYSJMBI1	0Ah
JTAG mailbox output 0	SYSJMBO0	0Ch
JTAG mailbox output 1	SYSJMBO1	0Eh
Bus Error vector generator	SYSBERRIV	18h
User NMI vector generator	SYSUNIV	1Ah
System NMI vector generator	SYSSNIV	1Ch
Reset vector generator	SYSRSTIV	1Eh

Table 9-20. Shared Reference Registers (Base Address: 01B0h)

REGISTER DESCRIPTION	REGISTER	OFFSET
Shared reference control	REFCTL	00h

Table 9-21. Port P1, P2 Registers (Base Address: 0200h)

REGISTER DESCRIPTION	REGISTER	OFFSET
Port P1 input	P1IN	00h
Port P1 output	P1OUT	02h
Port P1 direction	P1DIR	04h
Port P1 resistor enable	P1REN	06h
Port P1 drive strength	P1DS	08h
Port P1 selection	P1SEL	0Ah
Port P1 interrupt vector word	P1IV	0Eh
Port P1 interrupt edge select	P1IES	18h
Port P1 interrupt enable	P1IE	1Ah
Port P1 interrupt flag	P1IFG	1Ch
Port P2 input	P2IN	01h
Port P2 output	P2OUT	03h
Port P2 direction	P2DIR	05h
Port P2 resistor enable	P2REN	07h
Port P2 drive strength	P2DS	09h
Port P2 selection	P2SEL	0Bh
Port P2 interrupt vector word	P2IV	1Eh
Port P2 interrupt edge select	P2IES	19h
Port P2 interrupt enable	P2IE	1Bh
Port P2 interrupt flag	P2IFG	1Dh

Table 9-22. Port P3, P4 Registers (Base Address: 0220h)

REGISTER DESCRIPTION	REGISTER	OFFSET
Port P3 input	P3IN	00h
Port P3 output	P3OUT	02h
Port P3 direction	P3DIR	04h
Port P3 resistor enable	P3REN	06h
Port P3 drive strength	P3DS	08h
Port P3 selection	P3SEL	0Ah
Port P4 input	P4IN	01h
Port P4 output	P4OUT	03h
Port P4 direction	P4DIR	05h
Port P4 resistor enable	P4REN	07h
Port P4 drive strength	P4DS	09h
Port P4 selection	P4SEL	0Bh

Table 9-23. Port P5, P6 Registers (Base Address: 0240h)

REGISTER DESCRIPTION	REGISTER	OFFSET
Port P5 input	P5IN	00h
Port P5 output	P5OUT	02h
Port P5 direction	P5DIR	04h
Port P5 resistor enable	P5REN	06h
Port P5 drive strength	P5DS	08h
Port P5 selection	P5SEL	0Ah
Port P6 input	P6IN	01h
Port P6 output	P6OUT	03h
Port P6 direction	P6DIR	05h
Port P6 resistor enable	P6REN	07h
Port P6 drive strength	P6DS	09h
Port P6 selection	P6SEL	0Bh

Table 9-24. Port P7, P8 Registers (Base Address: 0260h)

REGISTER DESCRIPTION	REGISTER	OFFSET
Port P7 input	P7IN	00h
Port P7 output	P7OUT	02h
Port P7 direction	P7DIR	04h
Port P7 resistor enable	P7REN	06h
Port P7 drive strength	P7DS	08h
Port P7 selection	P7SEL	0Ah
Port P8 input	P8IN	01h
Port P8 output	P8OUT	03h
Port P8 direction	P8DIR	05h
Port P8 resistor enable	P8REN	07h
Port P8 drive strength	P8DS	09h
Port P8 selection	P8SEL	0Bh

Table 9-25. Port P9, P10 Registers (Base Address: 0280h)

REGISTER DESCRIPTION	REGISTER	OFFSET
Port P9 input	P9IN	00h
Port P9 output	P9OUT	02h
Port P9 direction	P9DIR	04h
Port P9 resistor enable	P9REN	06h
Port P9 drive strength	P9DS	08h
Port P9 selection	P9SEL	0Ah
Port P10 input	P10IN	01h
Port P10 output	P10OUT	03h
Port P10 direction	P10DIR	05h
Port P10 resistor enable	P10REN	07h
Port P10 drive strength	P10DS	09h
Port P10 selection	P10SEL	0Bh

Table 9-26. Port P11 Registers (Base Address: 02A0h)

REGISTER DESCRIPTION	REGISTER	OFFSET
Port P11 input	P11IN	00h
Port P11 output	P11OUT	02h
Port P11 direction	P11DIR	04h
Port P11 resistor enable	P11REN	06h
Port P11 drive strength	P11DS	08h
Port P11 selection	P11SEL	0Ah

Table 9-27. Port J Registers (Base Address: 0320h)

REGISTER DESCRIPTION	REGISTER	OFFSET
Port PJ input	PJIN	00h
Port PJ output	PJOUT	02h
Port PJ direction	PJDIR	04h
Port PJ resistor enable	PJREN	06h
Port PJ drive strength	PJDS	08h

Table 9-28. TA0 Registers (Base Address: 0340h)

REGISTER DESCRIPTION	REGISTER	OFFSET
TA0 control	TA0CTL	00h
Capture/compare control 0	TA0CCTL0	02h
Capture/compare control 1	TA0CCTL1	04h
Capture/compare control 2	TA0CCTL2	06h
Capture/compare control 3	TA0CCTL3	08h
Capture/compare control 4	TA0CCTL4	0Ah
TA0 counter	TA0R	10h
Capture/compare 0	TA0CCR0	12h
Capture/compare 1	TA0CCR1	14h
Capture/compare 2	TA0CCR2	16h
Capture/compare 3	TA0CCR3	18h
Capture/compare 4	TA0CCR4	1Ah
TA0 expansion 0	TA0EX0	20h
TA0 interrupt vector	TA0IV	2Eh

Table 9-29. TA1 Registers (Base Address: 0380h)

REGISTER DESCRIPTION	REGISTER	OFFSET
TA1 control	TA1CTL	00h
Capture/compare control 0	TA1CCTL0	02h
Capture/compare control 1	TA1CCTL1	04h
Capture/compare control 2	TA1CCTL2	06h
TA1 counter	TA1R	10h
Capture/compare 0	TA1CCR0	12h
Capture/compare 1	TA1CCR1	14h
Capture/compare 2	TA1CCR2	16h
TA1 expansion 0	TA1EX0	20h
TA1 interrupt vector	TA1IV	2Eh

Table 9-30. TB0 Registers (Base Address: 03C0h)

REGISTER DESCRIPTION	REGISTER	OFFSET
TB0 control	TB0CTL	00h
Capture/compare control 0	TB0CCTL0	02h
Capture/compare control 1	TB0CCTL1	04h
Capture/compare control 2	TB0CCTL2	06h
Capture/compare control 3	TB0CCTL3	08h
Capture/compare control 4	TB0CCTL4	0Ah
Capture/compare control 5	TB0CCTL5	0Ch
Capture/compare control 6	TB0CCTL6	0Eh
TB0 counter	TB0R	10h
Capture/compare 0	TB0CCR0	12h
Capture/compare 1	TB0CCR1	14h
Capture/compare 2	TB0CCR2	16h
Capture/compare 3	TB0CCR3	18h
Capture/compare 4	TB0CCR4	1Ah
Capture/compare 5	TB0CCR5	1Ch
Capture/compare 6	TB0CCR6	1Eh
TB0 expansion 0	TB0EX0	20h
TB0 interrupt vector	TB0IV	2Eh

Table 9-31. Real Time Clock Registers (Base Address: 04A0h)

REGISTER DESCRIPTION	REGISTER	OFFSET
RTC control 0	RTCCTL0	00h
RTC control 1	RTCCTL1	01h
RTC control 2	RTCCTL2	02h
RTC control 3	RTCCTL3	03h
RTC prescaler 0 control	RTCPS0CTL	08h
RTC prescaler 1 control	RTCPS1CTL	0Ah
RTC prescaler 0	RTCPS0	0Ch
RTC prescaler 1	RTCPS1	0Dh
RTC interrupt vector word	RTCIV	0Eh
RTC seconds/counter 1	RTCSEC/RTCNT1	10h
RTC minutes/counter 2	RTCMIN/RTCNT2	11h
RTC hours/counter 3	RTCHOUR/RTCNT3	12h
RTC day of week/counter 4	RTCADOW/RTCNT4	13h
RTC days	RTCDAY	14h
RTC month	RTCMON	15h
RTC year low	RTCYEARL	16h
RTC year high	RTCYEARH	17h
RTC alarm minutes	RTCAMIN	18h
RTC alarm hours	RTCAHOUR	19h
RTC alarm day of week	RTCADOW	1Ah
RTC alarm days	RTCADAY	1Bh

Table 9-32. 32-Bit Hardware Multiplier Registers (Base Address: 04C0h)

REGISTER DESCRIPTION	REGISTER	OFFSET
16-bit operand 1 – multiply	MPY	00h
16-bit operand 1 – signed multiply	MPYS	02h
16-bit operand 1 – multiply accumulate	MAC	04h
16-bit operand 1 – signed multiply accumulate	MACS	06h
16-bit operand 2	OP2	08h
16 × 16 result low word	RESLO	0Ah
16 × 16 result high word	RESHI	0Ch
16 × 16 sum extension	SUMEXT	0Eh
32-bit operand 1 – multiply low word	MPY32L	10h
32-bit operand 1 – multiply high word	MPY32H	12h
32-bit operand 1 – signed multiply low word	MPYS32L	14h
32-bit operand 1 – signed multiply high word	MPYS32H	16h
32-bit operand 1 – multiply accumulate low word	MAC32L	18h
32-bit operand 1 – multiply accumulate high word	MAC32H	1Ah
32-bit operand 1 – signed multiply accumulate low word	MACS32L	1Ch
32-bit operand 1 – signed multiply accumulate high word	MACS32H	1Eh
32-bit operand 2 – low word	OP2L	20h
32-bit operand 2 – high word	OP2H	22h
32 × 32 result 0 – least significant word	RES0	24h
32 × 32 result 1	RES1	26h
32 × 32 result 2	RES2	28h
32 × 32 result 3 – most significant word	RES3	2Ah
MPY32 control 0	MPY32CTL0	2Ch

**Table 9-33. DMA Registers (Base Address DMA General Control: 0500h,
DMA Channel 0: 0510h, DMA Channel 1: 0520h, DMA Channel 2: 0530h)**

REGISTER DESCRIPTION	REGISTER	OFFSET
DMA channel 0 control	DMA0CTL	00h
DMA channel 0 source address low	DMA0SAL	02h
DMA channel 0 source address high	DMA0SAH	04h
DMA channel 0 destination address low	DMA0DAL	06h
DMA channel 0 destination address high	DMA0DAH	08h
DMA channel 0 transfer size	DMA0SZ	0Ah
DMA channel 1 control	DMA1CTL	00h
DMA channel 1 source address low	DMA1SAL	02h
DMA channel 1 source address high	DMA1SAH	04h
DMA channel 1 destination address low	DMA1DAL	06h
DMA channel 1 destination address high	DMA1DAH	08h
DMA channel 1 transfer size	DMA1SZ	0Ah
DMA channel 2 control	DMA2CTL	00h
DMA channel 2 source address low	DMA2SAL	02h
DMA channel 2 source address high	DMA2SAH	04h
DMA channel 2 destination address low	DMA2DAL	06h
DMA channel 2 destination address high	DMA2DAH	08h
DMA channel 2 transfer size	DMA2SZ	0Ah
DMA module control 0	DMACTL0	00h
DMA module control 1	DMACTL1	02h
DMA module control 2	DMACTL2	04h
DMA module control 3	DMACTL3	06h
DMA module control 4	DMACTL4	08h
DMA interrupt vector	DMAIV	0Eh

Table 9-34. USCI_A0 Registers (Base Address: 05C0h)

REGISTER DESCRIPTION	REGISTER	OFFSET
USCI control 1	UCA0CTL1	00h
USCI control 0	UCA0CTL0	01h
USCI baud rate 0	UCA0BR0	06h
USCI baud rate 1	UCA0BR1	07h
USCI modulation control	UCA0MCTL	08h
USCI status	UCA0STAT	0Ah
USCI receive buffer	UCA0RXBUF	0Ch
USCI transmit buffer	UCA0TXBUF	0Eh
USCI LIN control	UCA0ABCTL	10h
USCI IrDA transmit control	UCA0IRTCTL	12h
USCI IrDA receive control	UCA0IRRCTL	13h
USCI interrupt enable	UCA0IE	1Ch
USCI interrupt flags	UCA0IFG	1Dh
USCI interrupt vector word	UCA0IV	1Eh

Table 9-35. USCI_B0 Registers (Base Address: 05E0h)

REGISTER DESCRIPTION	REGISTER	OFFSET
USCI synchronous control 1	UCB0CTL1	00h
USCI synchronous control 0	UCB0CTL0	01h
USCI synchronous bit rate 0	UCB0BR0	06h
USCI synchronous bit rate 1	UCB0BR1	07h
USCI synchronous status	UCB0STAT	0Ah
USCI synchronous receive buffer	UCB0RXBUF	0Ch
USCI synchronous transmit buffer	UCB0TXBUF	0Eh
USCI I2C own address	UCB0I2COA	10h
USCI I2C slave address	UCB0I2CSA	12h
USCI interrupt enable	UCB0IE	1Ch
USCI interrupt flags	UCB0IFG	1Dh
USCI interrupt vector word	UCB0IV	1Eh

Table 9-36. USCI_A1 Registers (Base Address: 0600h)

REGISTER DESCRIPTION	REGISTER	OFFSET
USCI control 1	UCA1CTL1	00h
USCI control 0	UCA1CTL0	01h
USCI baud rate 0	UCA1BR0	06h
USCI baud rate 1	UCA1BR1	07h
USCI modulation control	UCA1MCTL	08h
USCI status	UCA1STAT	0Ah
USCI receive buffer	UCA1RXBUF	0Ch
USCI transmit buffer	UCA1TXBUF	0Eh
USCI LIN control	UCA1ABCTL	10h
USCI IrDA transmit control	UCA1IRTCTL	12h
USCI IrDA receive control	UCA1IRRCTL	13h
USCI interrupt enable	UCA1IE	1Ch
USCI interrupt flags	UCA1IFG	1Dh
USCI interrupt vector word	UCA1IV	1Eh

Table 9-37. USCI_B1 Registers (Base Address: 0620h)

REGISTER DESCRIPTION	REGISTER	OFFSET
USCI synchronous control 1	UCB1CTL1	00h
USCI synchronous control 0	UCB1CTL0	01h
USCI synchronous bit rate 0	UCB1BR0	06h
USCI synchronous bit rate 1	UCB1BR1	07h
USCI synchronous status	UCB1STAT	0Ah
USCI synchronous receive buffer	UCB1RXBUF	0Ch
USCI synchronous transmit buffer	UCB1TXBUF	0Eh
USCI I2C own address	UCB1I2COA	10h
USCI I2C slave address	UCB1I2CSA	12h
USCI interrupt enable	UCB1IE	1Ch
USCI interrupt flags	UCB1IFG	1Dh
USCI interrupt vector word	UCB1IV	1Eh

Table 9-38. USCI_A2 Registers (Base Address: 0640h)

REGISTER DESCRIPTION	REGISTER	OFFSET
USCI control 1	UCA2CTL1	00h
USCI control 0	UCA2CTL0	01h
USCI baud rate 0	UCA2BR0	06h
USCI baud rate 1	UCA2BR1	07h
USCI modulation control	UCA2MCTL	08h
USCI status	UCA2STAT	0Ah
USCI receive buffer	UCA2RXBUF	0Ch
USCI transmit buffer	UCA2TXBUF	0Eh
USCI LIN control	UCA2ABCTL	10h
USCI IrDA transmit control	UCA2IRTCTL	12h
USCI IrDA receive control	UCA2IRRCTL	13h
USCI interrupt enable	UCA2IE	1Ch
USCI interrupt flags	UCA2IFG	1Dh
USCI interrupt vector word	UCA2IV	1Eh

Table 9-39. USCI_B2 Registers (Base Address: 0660h)

REGISTER DESCRIPTION	REGISTER	OFFSET
USCI synchronous control 1	UCB2CTL1	00h
USCI synchronous control 0	UCB2CTL0	01h
USCI synchronous bit rate 0	UCB2BR0	06h
USCI synchronous bit rate 1	UCB2BR1	07h
USCI synchronous status	UCB2STAT	0Ah
USCI synchronous receive buffer	UCB2RXBUF	0Ch
USCI synchronous transmit buffer	UCB2TXBUF	0Eh
USCI I2C own address	UCB2I2COA	10h
USCI I2C slave address	UCB2I2CSA	12h
USCI interrupt enable	UCB2IE	1Ch
USCI interrupt flags	UCB2IFG	1Dh
USCI interrupt vector word	UCB2IV	1Eh

Table 9-40. USCI_A3 Registers (Base Address: 0680h)

REGISTER DESCRIPTION	REGISTER	OFFSET
USCI control 1	UCA3CTL1	00h
USCI control 0	UCA3CTL0	01h
USCI baud rate 0	UCA3BR0	06h
USCI baud rate 1	UCA3BR1	07h
USCI modulation control	UCA3MCTL	08h
USCI status	UCA3STAT	0Ah
USCI receive buffer	UCA3RXBUF	0Ch
USCI transmit buffer	UCA3TXBUF	0Eh
USCI LIN control	UCA3ABCTL	10h
USCI IrDA transmit control	UCA3IRTCTL	12h
USCI IrDA receive control	UCA3IRRCTL	13h
USCI interrupt enable	UCA3IE	1Ch
USCI interrupt flags	UCA3IFG	1Dh
USCI interrupt vector word	UCA3IV	1Eh

Table 9-41. USCI_B3 Registers (Base Address: 06A0h)

REGISTER DESCRIPTION	REGISTER	OFFSET
USCI synchronous control 1	UCB3CTL1	00h
USCI synchronous control 0	UCB3CTL0	01h
USCI synchronous bit rate 0	UCB3BR0	06h
USCI synchronous bit rate 1	UCB3BR1	07h
USCI synchronous status	UCB3STAT	0Ah
USCI synchronous receive buffer	UCB3RXBUF	0Ch
USCI synchronous transmit buffer	UCB3TXBUF	0Eh
USCI I2C own address	UCB3I2COA	10h
USCI I2C slave address	UCB3I2CSA	12h
USCI interrupt enable	UCB3IE	1Ch
USCI interrupt flags	UCB3IFG	1Dh
USCI interrupt vector word	UCB3IV	1Eh

Table 9-42. ADC12_A Registers (Base Address: 0700h)

REGISTER DESCRIPTION	REGISTER	OFFSET
Control 0	ADC12CTL0	00h
Control 1	ADC12CTL1	02h
Control 2	ADC12CTL2	04h
Interrupt flag	ADC12IFG	0Ah
Interrupt enable	ADC12IE	0Ch
Interrupt vector word	ADC12IV	0Eh
ADC memory control 0	ADC12MCTL0	10h
ADC memory control 1	ADC12MCTL1	11h
ADC memory control 2	ADC12MCTL2	12h
ADC memory control 3	ADC12MCTL3	13h
ADC memory control 4	ADC12MCTL4	14h
ADC memory control 5	ADC12MCTL5	15h
ADC memory control 6	ADC12MCTL6	16h
ADC memory control 7	ADC12MCTL7	17h
ADC memory control 8	ADC12MCTL8	18h
ADC memory control 9	ADC12MCTL9	19h
ADC memory control 10	ADC12MCTL10	1Ah
ADC memory control 11	ADC12MCTL11	1Bh
ADC memory control 12	ADC12MCTL12	1Ch
ADC memory control 13	ADC12MCTL13	1Dh
ADC memory control 14	ADC12MCTL14	1Eh
ADC memory control 15	ADC12MCTL15	1Fh
Conversion memory 0	ADC12MEM0	20h
Conversion memory 1	ADC12MEM1	22h
Conversion memory 2	ADC12MEM2	24h
Conversion memory 3	ADC12MEM3	26h
Conversion memory 4	ADC12MEM4	28h
Conversion memory 5	ADC12MEM5	2Ah
Conversion memory 6	ADC12MEM6	2Ch
Conversion memory 7	ADC12MEM7	2Eh
Conversion memory 8	ADC12MEM8	30h
Conversion memory 9	ADC12MEM9	32h
Conversion memory 10	ADC12MEM10	34h
Conversion memory 11	ADC12MEM11	36h
Conversion memory 12	ADC12MEM12	38h
Conversion memory 13	ADC12MEM13	3Ah
Conversion memory 14	ADC12MEM14	3Ch
Conversion memory 15	ADC12MEM15	3Eh

9.10 Input/Output Diagrams

9.10.1 Port P1 (P1.0 to P1.7) Input/Output With Schmitt Trigger

Figure 9-2 shows the port diagram. Table 9-43 summarizes the selection of the pin functions.

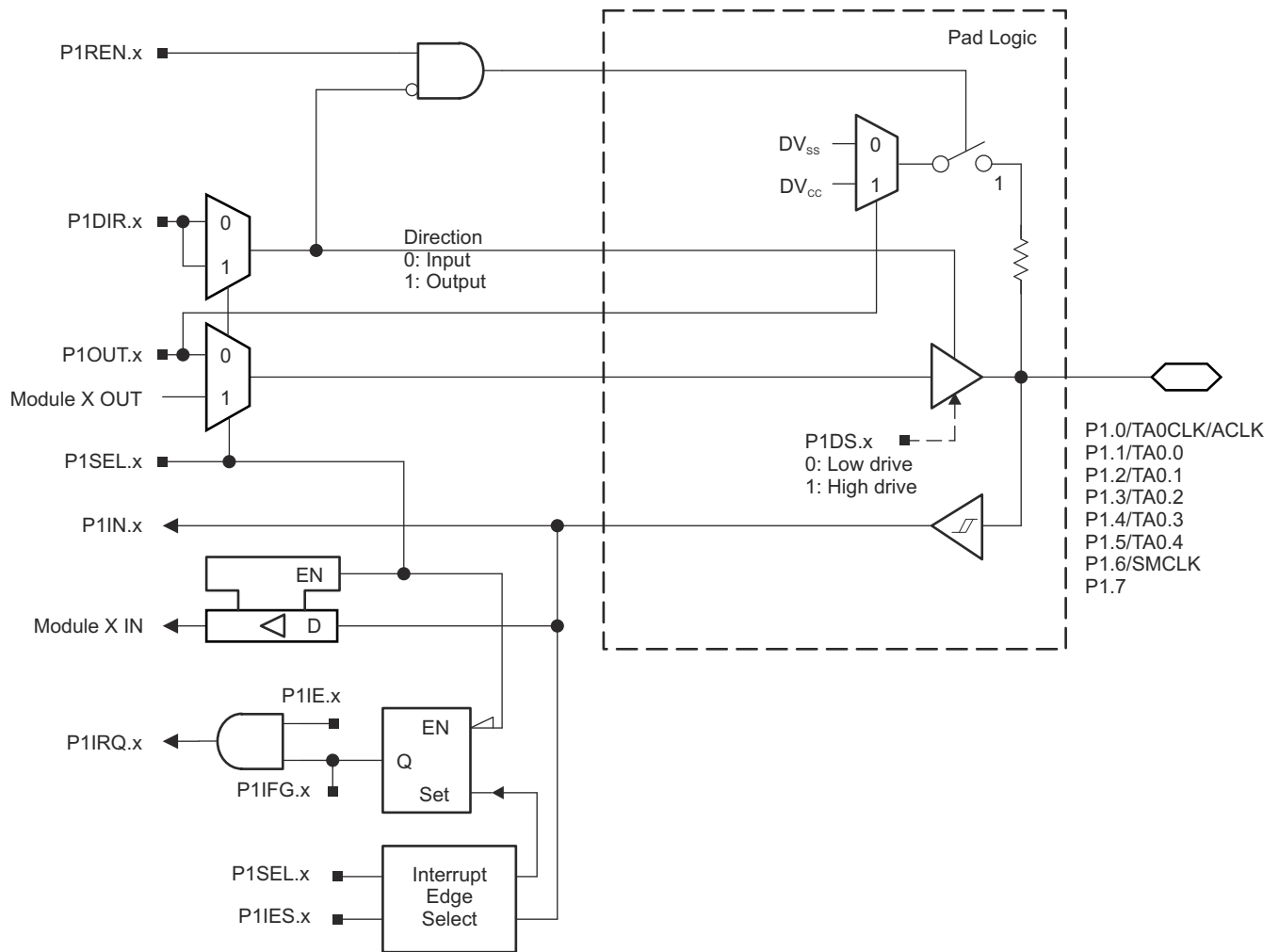

Figure 9-2. Port P1 (P1.0 to P1.7) Diagram

Table 9-43. Port P1 (P1.0 to P1.7) Pin Functions

PIN NAME (P1.x)	x	FUNCTION	CONTROL BITS OR SIGNALS	
			P1DIR.x	P1SEL.x
P1.0/TA0CLK/ACLK	0	P1.0 (I/O)	I: 0; O: 1	0
		TA0.TA0CLK	0	1
		ACLK	1	1
P1.1/TA0.0	1	P1.1 (I/O)	I: 0; O: 1	0
		TA0.CCI0A	0	1
		TA0.0	1	1
P1.2/TA0.1	2	P1.2 (I/O)	I: 0; O: 1	0
		TA0.CCI1A	0	1
		TA0.1	1	1
P1.3/TA0.2	3	P1.3 (I/O)	I: 0; O: 1	0
		TA0.CCI2A	0	1
		TA0.2	1	1
P1.4/TA0.3	4	P1.4 (I/O)	I: 0; O: 1	0
		TA0.CCI3A	0	1
		TA0.3	1	1
P1.5/TA0.4	5	P1.5 (I/O)	I: 0; O: 1	0
		TA0.CCI4A	0	1
		TA0.4	1	1
P1.6/SMCLK	6	P1.6 (I/O)	I: 0; O: 1	0
		SMCLK	1	1
P1.7	7	P1.7 (I/O)	I: 0; O: 1	0

9.10.2 Port P2 (P2.0 to P2.7) Input/Output With Schmitt Trigger

Figure 9-3 shows the port diagram. Table 9-44 summarizes the selection of the pin functions.

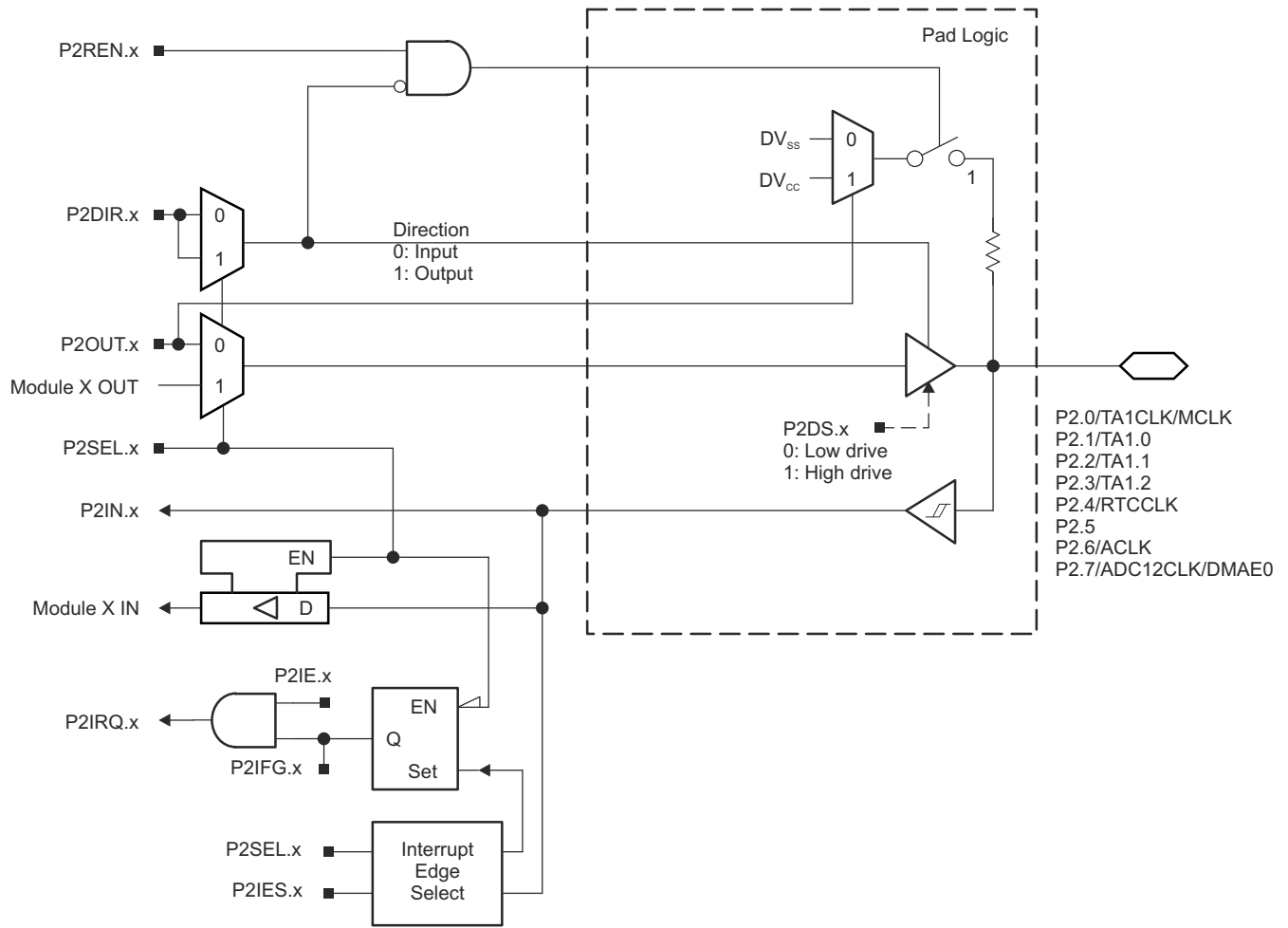

Figure 9-3. Port P2 (P2.0 to P2.7) Diagram

Table 9-44. Port P2 (P2.0 to P2.7) Pin Functions

PIN NAME (P2.x)	x	FUNCTION	CONTROL BITS OR SIGNALS	
			P2DIR.x	P2SEL.x
P2.0/TA1CLK/MCLK	0	P2.0 (I/O)	I: 0; O: 1	0
		TA1CLK	0	1
		MCLK	1	1
P2.1/TA1.0	1	P2.1 (I/O)	I: 0; O: 1	0
		TA1.CCI0A	0	1
		TA1.0	1	1
P2.2/TA1.1	2	P2.2 (I/O)	I: 0; O: 1	0
		TA1.CCI1A	0	1
		TA1.1	1	1
P2.3/TA1.2	3	P2.3 (I/O)	I: 0; O: 1	0
		TA1.CCI2A	0	1
		TA1.2	1	1
P2.4/RTCCLK	4	P2.4 (I/O)	I: 0; O: 1	0
		RTCCLK	1	1
P2.5	5	P2.5 (I/O)	I: 0; O: 1	0
P2.6/ACLK	6	P2.6 (I/O)	I: 0; O: 1	0
		ACLK	1	1
P2.7/ADC12CLK/DMAE0	7	P2.7 (I/O)	I: 0; O: 1	0
		DMAE0	0	1
		ADC12CLK	1	1

9.10.3 Port P3 (P3.0 to P3.7) Input/Output With Schmitt Trigger

Figure 9-4 shows the port diagram. Table 9-45 summarizes the selection of the pin functions.

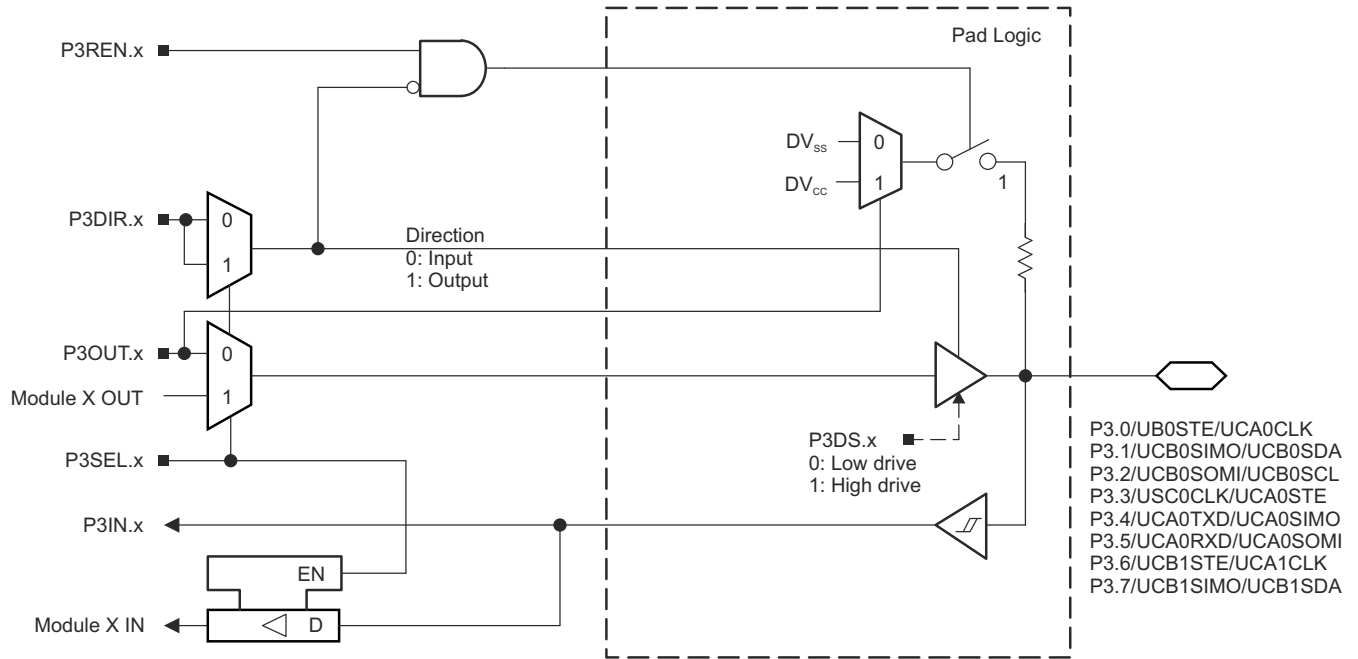

Figure 9-4. Port P3 (P3.0 to P3.7) Diagram

Table 9-45. Port P3 (P3.0 to P3.7) Pin Functions

PIN NAME (P3.x)	x	FUNCTION	CONTROL BITS OR SIGNALS ⁽¹⁾	
			P3DIR.x	P3SEL.x
P3.0/UCB0STE/UCA0CLK	0	P3.0 (I/O)	I: 0; O: 1	0
		UCB0STE/UCA0CLK ^{(2) (4)}	X	1
P3.1/UCB0SIMO/UCB0SDA	1	P3.1 (I/O)	I: 0; O: 1	0
		UCB0SIMO/UCB0SDA ^{(2) (3)}	X	1
P3.2/UCB0SOMI/UCB0SCL	2	P3.2 (I/O)	I: 0; O: 1	0
		UCB0SOMI/UCB0SCL ^{(2) (3)}	X	1
P3.3/UCB0CLK/UCA0STE	3	P3.3 (I/O)	I: 0; O: 1	0
		UCB0CLK/UCA0STE ^{(2) (5)}	X	1
P3.4/UCA0TXD/UCA0SIMO	4	P3.4 (I/O)	I: 0; O: 1	0
		UCA0TXD/UCA0SIMO ⁽²⁾	X	1
P3.5/UCA0RXD/UCA0SOMI	5	P3.5 (I/O)	I: 0; O: 1	0
		UCA0RXD/UCA0SOMI ⁽²⁾	X	1
P3.6/UCB1STE/UCA1CLK	6	P3.6 (I/O)	I: 0; O: 1	0
		UCB1STE/UCA1CLK ^{(2) (6)}	X	1
P3.7/UCB1SIMO/UCB1SDA	7	P3.7 (I/O)	I: 0; O: 1	0
		UCB1SIMO/UCB1SDA ^{(2) (3)}	X	1

(1) X = Don't care

(2) The pin direction is controlled by the USCI module.

(3) If the I²C functionality is selected, the output drives only the logical 0 to V_{SS} level.

(4) UCA0CLK function takes precedence over UCB0STE function. If the pin is required as UCA0CLK input or output, USCI_B0 is forced to 3-wire SPI mode if 4-wire SPI mode is selected.

(5) UCB0CLK function takes precedence over UCA0STE function. If the pin is required as UCB0CLK input or output, USCI_A0 is forced to 3-wire SPI mode if 4-wire SPI mode is selected.

(6) UCA1CLK function takes precedence over UCB1STE function. If the pin is required as UCA1CLK input or output, USCI_B1 is forced to 3-wire SPI mode if 4-wire SPI mode is selected.

9.10.4 Port P4 (P4.0 to P4.7) Input/Output With Schmitt Trigger

Figure 9-5 shows the port diagram. Table 9-46 summarizes the selection of the pin functions.

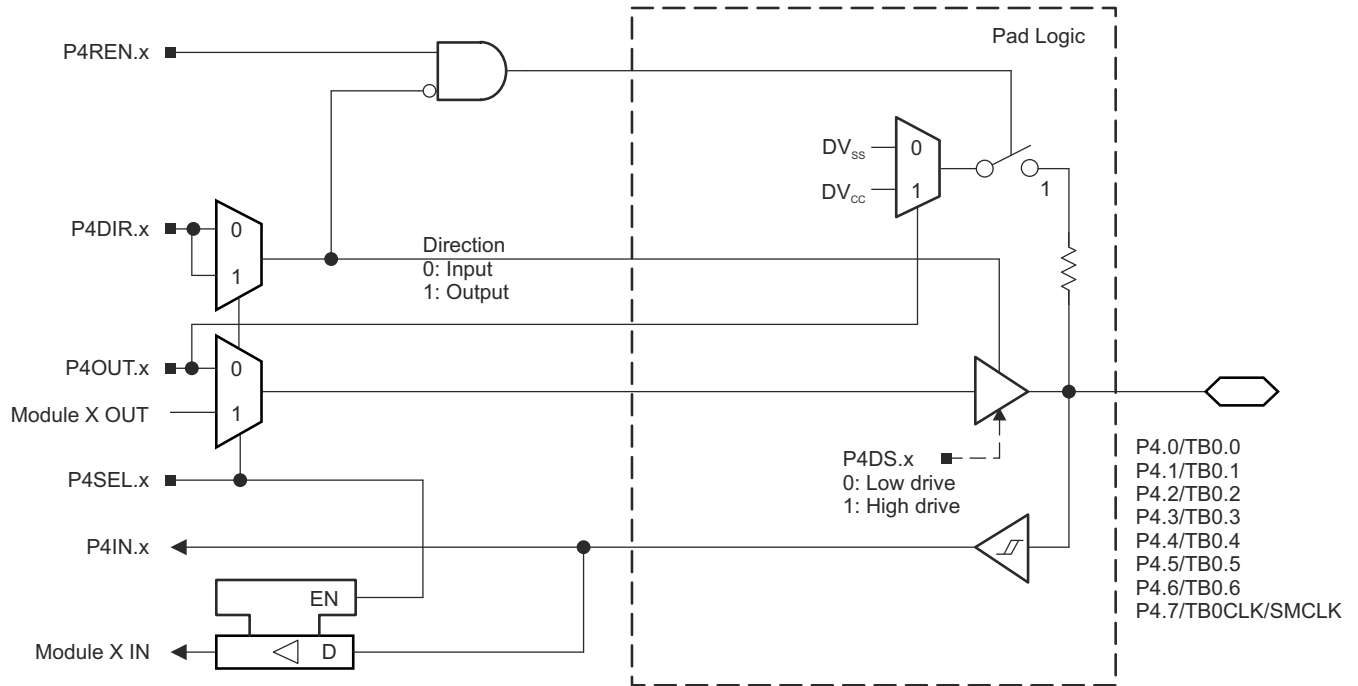

Figure 9-5. Port P4 (P4.0 to P4.7) Diagram

Table 9-46. Port P4 (P4.0 to P4.7) Pin Functions

PIN NAME (P4.x)	x	FUNCTION	CONTROL BITS OR SIGNALS	
			P4DIR.x	P4SEL.x
P4.0/TB0.0	0	4.0 (I/O)	I: 0; O: 1	0
		TB0.CCI0A and TB0.CCI0B	0	1
		TB0.0 ⁽¹⁾	1	1
P4.1/TB0.1	1	4.1 (I/O)	I: 0; O: 1	0
		TB0.CCI1A and TB0.CCI1B	0	1
		TB0.1 ⁽¹⁾	1	1
P4.2/TB0.2	2	4.2 (I/O)	I: 0; O: 1	0
		TB0.CCI2A and TB0.CCI2B	0	1
		TB0.2 ⁽¹⁾	1	1
P4.3/TB0.3	3	4.3 (I/O)	I: 0; O: 1	0
		TB0.CCI3A and TB0.CCI3B	0	1
		TB0.3 ⁽¹⁾	1	1
P4.4/TB0.5	4	4.4 (I/O)	I: 0; O: 1	0
		TB0.CCI4A and TB0.CCI4B	0	1
		TB0.4 ⁽¹⁾	1	1
P4.5/TB0.5	5	4.5 (I/O)	I: 0; O: 1	0
		TB0.CCI5A and TB0.CCI5B	0	1
		TB0.5 ⁽¹⁾	1	1
P4.6/TB0.6	6	4.6 (I/O)	I: 0; O: 1	0
		TB0.CCI6A and TB0.CCI6B	0	1
		TB0.6 ⁽¹⁾	1	1
P4.7/TB0CLK/SMCLK	7	4.7 (I/O)	I: 0; O: 1	0
		TB0CLK	0	1
		SMCLK	1	1

(1) Setting TBOUTH causes all Timer_B configured outputs to be set to high impedance.

9.10.5 Port P5 (P5.0 and P5.1) Input/Output With Schmitt Trigger

Figure 9-6 shows the port diagram. Table 9-47 summarizes the selection of the pin functions.

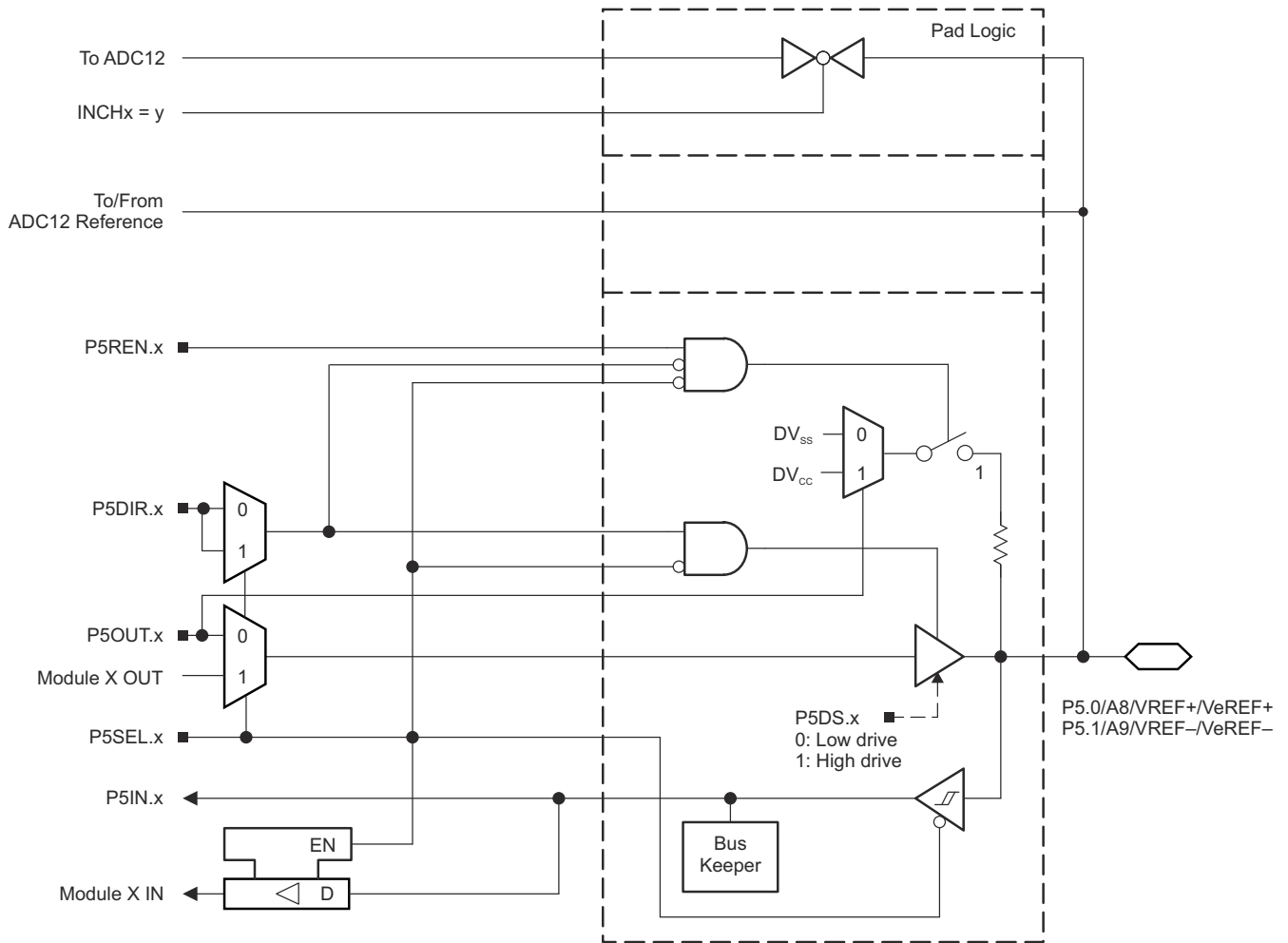

Figure 9-6. Port P5 (P5.0 and P5.1) Diagram

Table 9-47. Port P5 (P5.0 and P5.1) Pin Functions

PIN NAME (P5.x)	x	FUNCTION	CONTROL BITS OR SIGNALS ⁽¹⁾		
			P5DIR.x	P5SEL.x	REFOUT
P5.0/A8/VREF+/VeREF+	0	P5.0 (I/O) ⁽²⁾	I: 0; O: 1	0	X
		A8/VeREF+ ⁽³⁾	X	1	0
		A8/VREF+ ⁽⁴⁾	X	1	1
P5.1/A9/VREF-/VeREF-	1	P5.1 (I/O) ⁽²⁾	I: 0; O: 1	0	X
		A9/VeREF- ⁽⁵⁾	X	1	0
		A9/VREF- ⁽⁶⁾	X	1	1

- (1) X = Don't care
- (2) Default condition
- (3) Setting the P5SEL.0 bit disables the output driver and the input Schmitt trigger to prevent parasitic cross currents when applying analog signals. An external voltage can be applied to VeREF+ and used as the reference for the ADC12_A. Channel A8, when selected with the INCHx bits, is connected to the VREF+/VeREF+ pin.
- (4) Setting the P5SEL.0 bit disables the output driver and the input Schmitt trigger to prevent parasitic cross currents when applying analog signals. The ADC12_A, VREF+ reference is available at the pin. Channel A8, when selected with the INCHx bits, is connected to the VREF+/VeREF+ pin.
- (5) Setting the P5SEL.1 bit disables the output driver and the input Schmitt trigger to prevent parasitic cross currents when applying analog signals. An external voltage can be applied to VeREF- and used as the reference for the ADC12_A. Channel A9, when selected with the INCHx bits, is connected to the VREF-/VeREF- pin.
- (6) Setting the P5SEL.1 bit disables the output driver and the input Schmitt trigger to prevent parasitic cross currents when applying analog signals. The ADC12_A, VREF- reference is available at the pin. Channel A9, when selected with the INCHx bits, is connected to the VREF-/VeREF- pin.

9.10.6 Port P5 (P5.2 and P5.3) Input/Output With Schmitt Trigger

Figure 9-7 and Figure 9-8 show the port diagrams. Table 9-48 summarizes the selection of the pin functions.

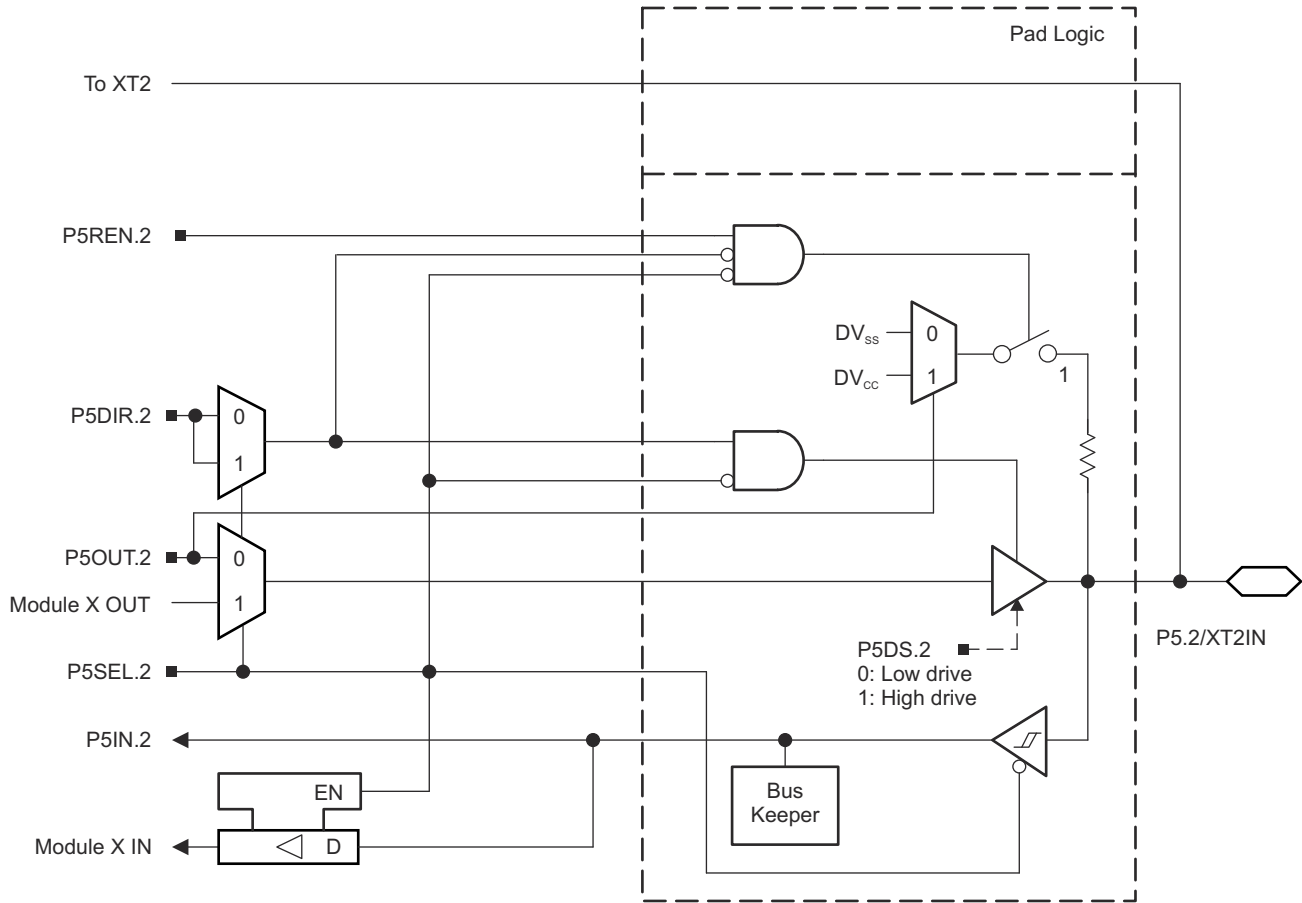

Figure 9-7. Port P5 (P5.2) Diagram

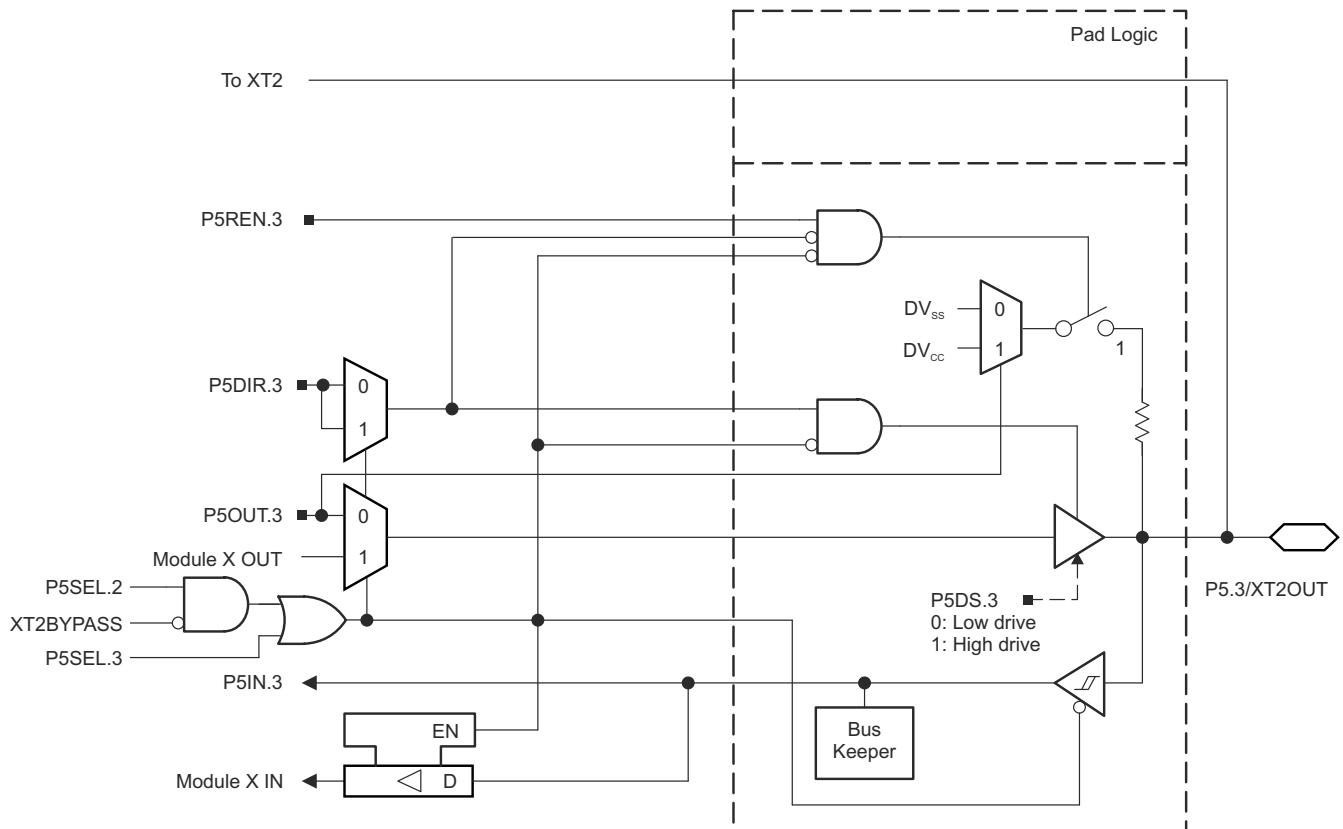

Figure 9-8. Port P5 (P5.3) Diagram

Table 9-48. Port P5 (P5.2 and P5.3) Pin Functions

PIN NAME (P5.x)	x	FUNCTION	CONTROL BITS OR SIGNALS ⁽¹⁾			
			P5DIR.x	P5SEL.2	P5SEL.3	XT2BYPASS
P5.2/XT2IN	2	P5.2 (I/O)	I: 0; O: 1	0	X	X
		XT2IN crystal mode ⁽²⁾	X	1	X	0
		XT2IN bypass mode ⁽²⁾	X	1	X	1
P5.3/XT2OUT	3	P5.3 (I/O)	I: 0; O: 1	0	0	X
		XT2OUT crystal mode ⁽³⁾	X	1	X	0
		P5.3 (I/O) ⁽³⁾	X	1	0	1

- (1) X = Don't care
- (2) Setting P5SEL.2 causes the general-purpose I/O to be disabled. Pending the setting of XT2BYPASS, P5.2 is configured for crystal mode or bypass mode.
- (3) Setting P5SEL.2 causes the general-purpose I/O to be disabled in crystal mode. When using bypass mode, P5.3 can be used as general-purpose I/O.

9.10.7 Port P5 (P5.4 to P5.7) Input/Output With Schmitt Trigger

Figure 9-9 shows the port diagram. Table 9-49 summarizes the selection of the pin functions.

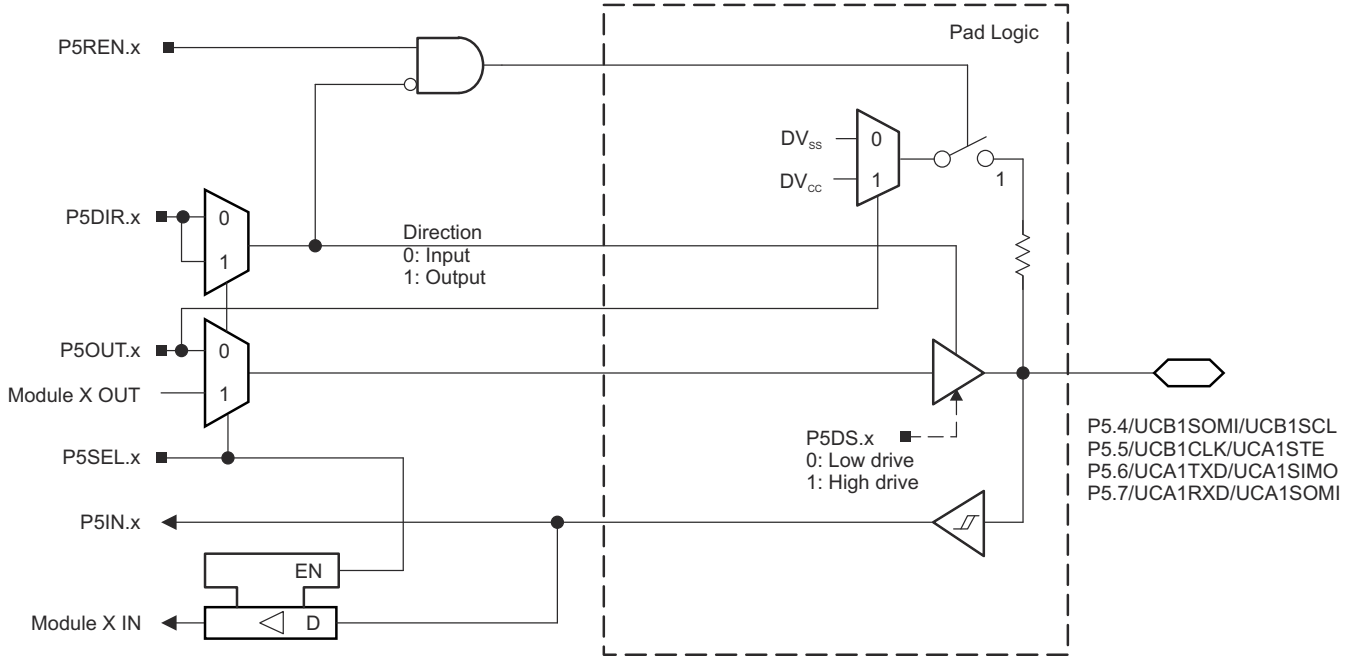

Figure 9-9. Port P5 (P5.4 to P5.7) Diagram

Table 9-49. Port P5 (P5.4 to P5.7) Pin Functions

PIN NAME (P5.x)	x	FUNCTION	CONTROL BITS OR SIGNALS ⁽¹⁾	
			P5DIR.x	P5SEL.x
P5.4/UCB1SOMI/UCB1SCL	4	P5.4 (I/O)	I: 0; O: 1	0
		UCB1SOMI/UCB1SCL ^{(2) (3)}	X	1
P5.5/UCB1CLK/UCA1STE	5	P5.5 (I/O)	I: 0; O: 1	0
		UCB1CLK/UCA1STE ^{(2) (4)}	X	1
P5.6/UCA1TXD/UCA1SIMO	6	P5.6 (I/O)	I: 0; O: 1	0
		UCA1TXD/UCA1SIMO ⁽²⁾	X	1
P5.7/UCA1RXD/UCA1SOMI	7	P5.7 (I/O)	I: 0; O: 1	0
		UCA1RXD/UCA1SOMI ⁽²⁾	X	1

- (1) X = Don't care
- (2) The pin direction is controlled by the USCI module.
- (3) If the I²C functionality is selected, the output drives only the logical 0 to V_{SS} level.
- (4) UCB1CLK function takes precedence over UCA1STE function. If the pin is required as UCB1CLK input or output, USCI_A1 is forced to 3-wire SPI mode if 4-wire SPI mode is selected.

9.10.8 Port P6 (P6.0 to P6.7) Input/Output With Schmitt Trigger

Figure 9-10 shows the port diagram. Table 9-50 summarizes the selection of the pin functions.

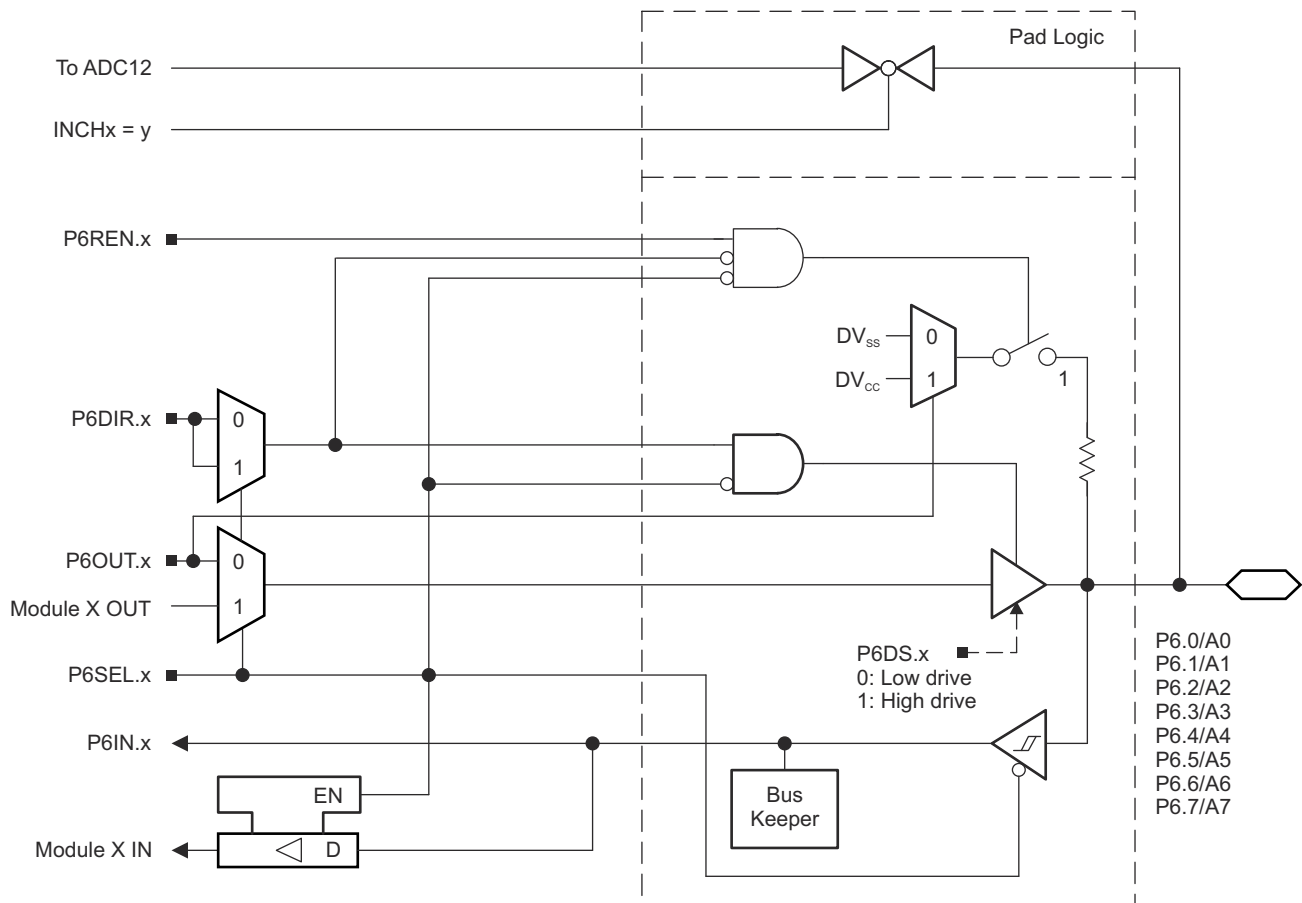

Figure 9-10. Port P6 (P6.0 to P6.7) Diagram

Table 9-50. Port P6 (P6.0 to P6.7) Pin Functions

PIN NAME (P6.x)	x	FUNCTION	CONTROL BITS OR SIGNALS ⁽¹⁾		
			P6DIR.x	P6SEL.x	INCHx
P6.0/A0	0	P6.0 (I/O)	I: 0; O: 1	0	X
		A0 ^{(2) (3)}	X	X	0
P6.1/A1	1	P6.1 (I/O)	I: 0; O: 1	0	X
		A1 ^{(2) (3)}	X	X	1
P6.2/A2	2	P6.2 (I/O)	I: 0; O: 1	0	X
		A2 ^{(2) (3)}	X	X	2
P6.3/A3	3	P6.3 (I/O)	I: 0; O: 1	0	X
		A3 ^{(2) (3)}	X	X	3
P6.4/A4	4	P6.4 (I/O)	I: 0; O: 1	0	X
		A4 ^{(2) (3)}	X	X	4
P6.5/A5	5	P6.5 (I/O)	I: 0; O: 1	0	X
		A5 ^{(1) (2) (3)}	X	X	5
P6.6/A6	6	P6.6 (I/O)	I: 0; O: 1	0	X
		A6 ^{(2) (3)}	X	X	6
P6.7/A7	7	P6.7 (I/O)	I: 0; O: 1	0	X
		A7 ^{(2) (3)}	X	X	7

(1) X = Don't care

(2) Setting the P6SEL.x bit disables the output driver and the input Schmitt trigger to prevent parasitic cross currents when applying analog signals.

(3) The ADC12_A channel Ax is connected internally to AV_{SS} if not selected by the respective INCHx bits.

9.10.9 Port P7 (P7.0 and P7.1) Input/Output With Schmitt Trigger

Figure 9-11 and Figure 9-12 show the port diagrams. Table 9-51 summarizes the selection of the pin functions.

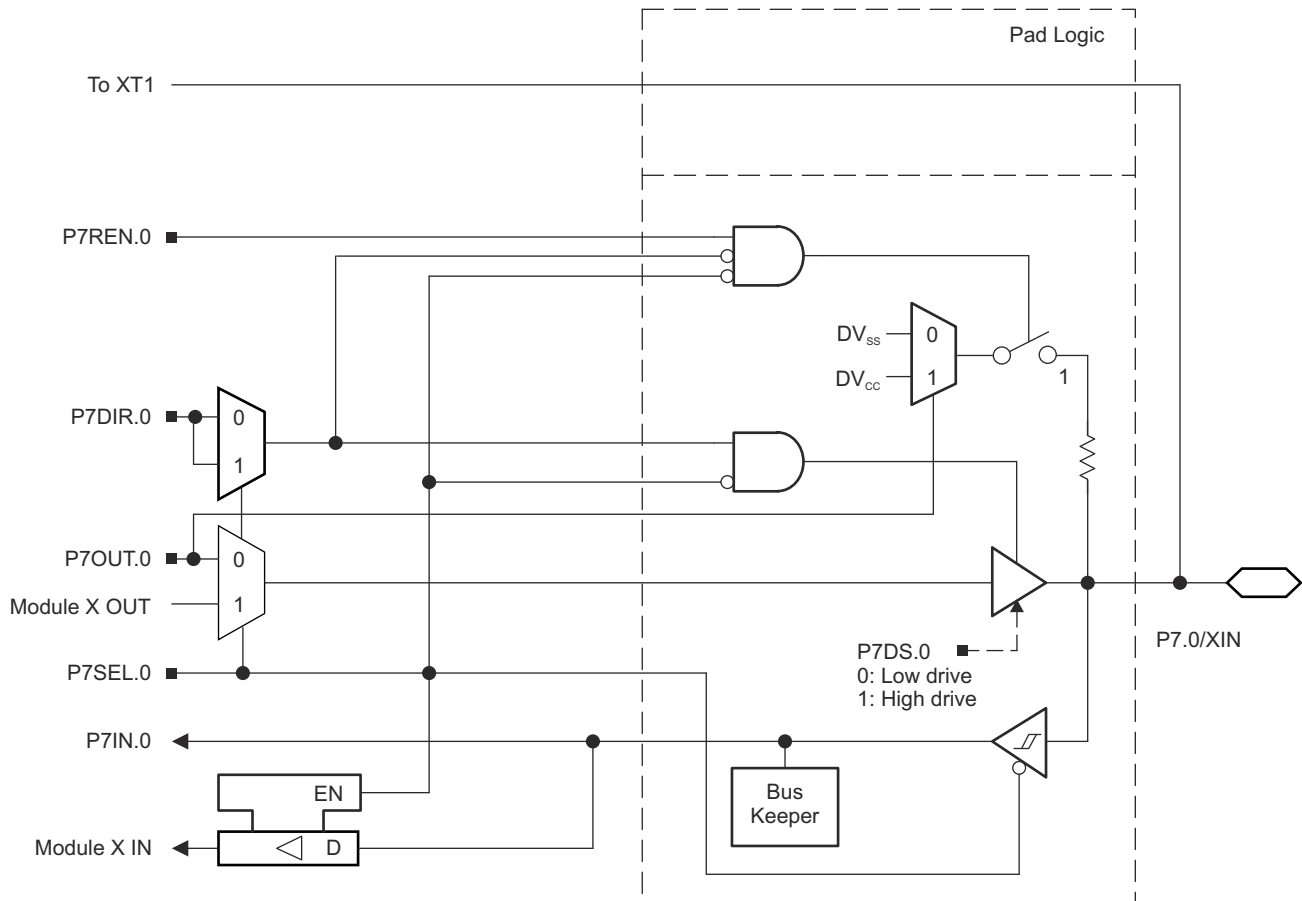

Figure 9-11. Port P7 (P7.0) Diagram

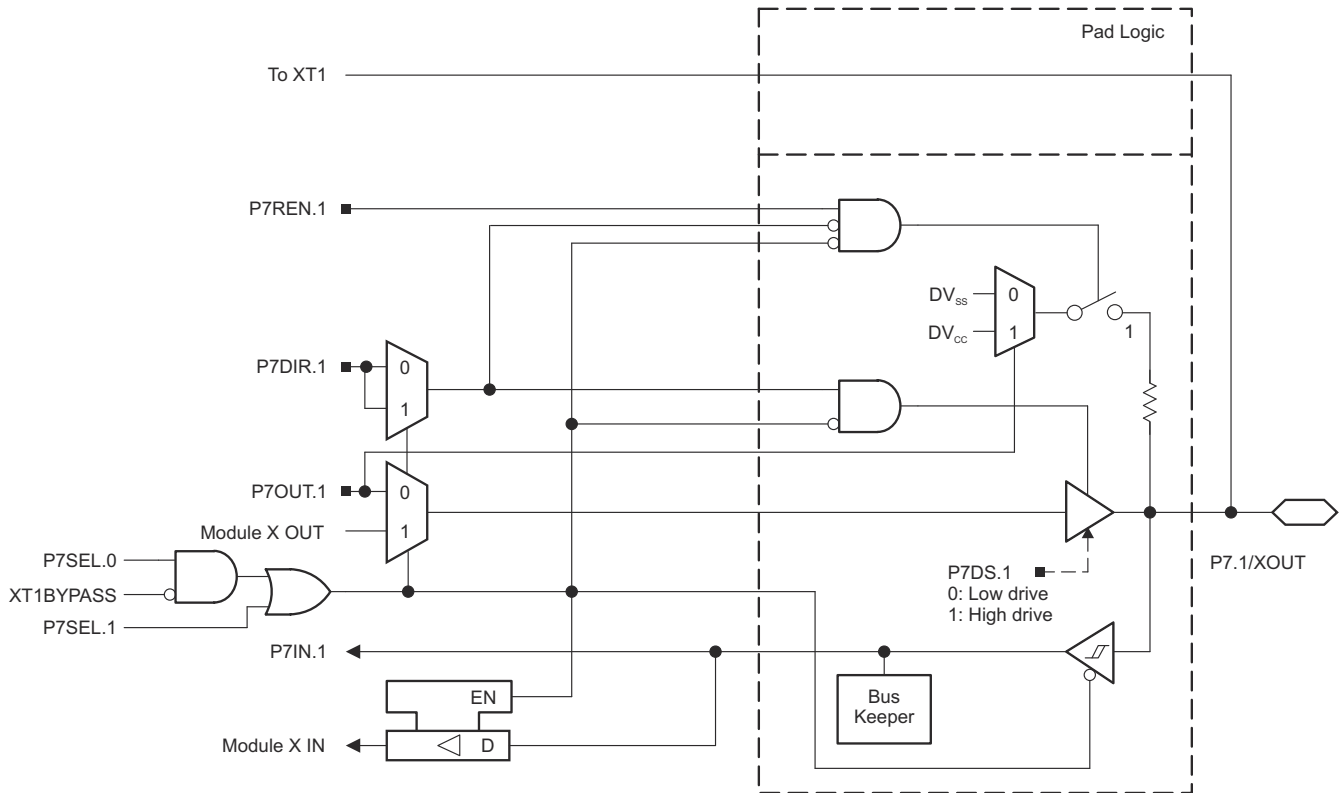

Figure 9-12. Port P7 (P7.1) Diagram

Table 9-51. Port P7 (P7.0 and P7.1) Pin Functions

PIN NAME (P7.x)	x	FUNCTION	CONTROL BITS OR SIGNALS ⁽¹⁾			
			P7DIR.x	P7SEL.0	P7SEL.1	XT1BYPASS
P7.0/XIN	0	P7.0 (I/O)	I: 0; O: 1	0	X	X
		XIN crystal mode ⁽²⁾	X	1	X	0
		XIN bypass mode ⁽²⁾	X	1	X	1
P7.1/XOUT	1	P7.1 (I/O)	I: 0; O: 1	0	0	X
		XOUT crystal mode ⁽³⁾	X	1	X	0
		P7.1 (I/O) ⁽³⁾	X	1	0	1

- (1) X = Don't care
(2) Setting P7SEL.0 causes the general-purpose I/O to be disabled. Pending the setting of XT1BYPASS, P7.0 is configured for crystal mode or bypass mode.
(3) Setting P7SEL.0 causes the general-purpose I/O to be disabled in crystal mode. When using bypass mode, P7.1 can be used as general-purpose I/O.

9.10.10 Port P7 (P7.2 and P7.3) Input/Output With Schmitt Trigger

Figure 9-13 shows the port diagram. Table 9-52 summarizes the selection of the pin functions.

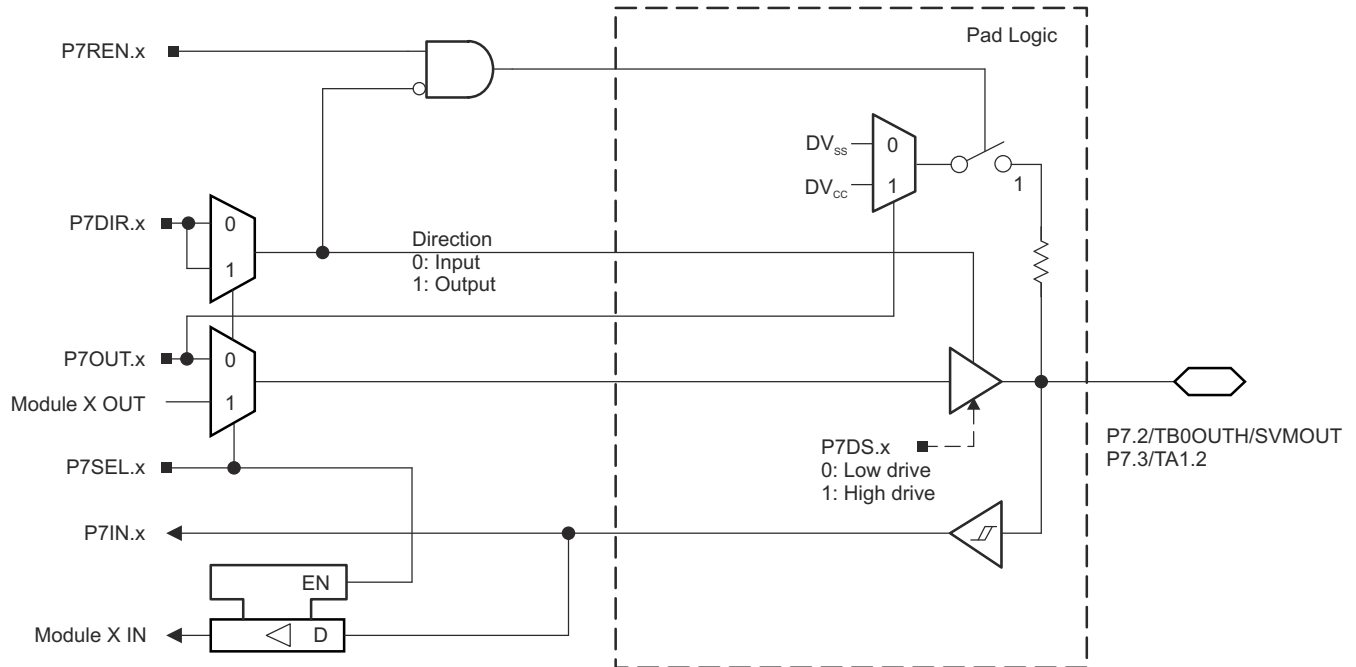

Figure 9-13. Port P7 (P7.2 and P7.3) Diagram

Table 9-52. Port P7 (P7.2 and P7.3) Pin Functions

PIN NAME (P7.x)	x	FUNCTION	CONTROL BITS OR SIGNALS	
			P7DIR.x	P7SEL.x
P7.2/TB0OUTH/SVMOUT	2	P7.2 (I/O)	I: 0; O: 1	0
		TB0OUTH	0	1
		SVMOUT	1	1
P7.3/TA1.2	3	P7.3 (I/O)	I: 0; O: 1	0
		TA1.CCI2B	0	1
		TA1.2	1	1

9.10.11 Port P7 (P7.4 to P7.7) Input/Output With Schmitt Trigger

Figure 9-14 shows the port diagram. Table 9-53 summarizes the selection of the pin functions.

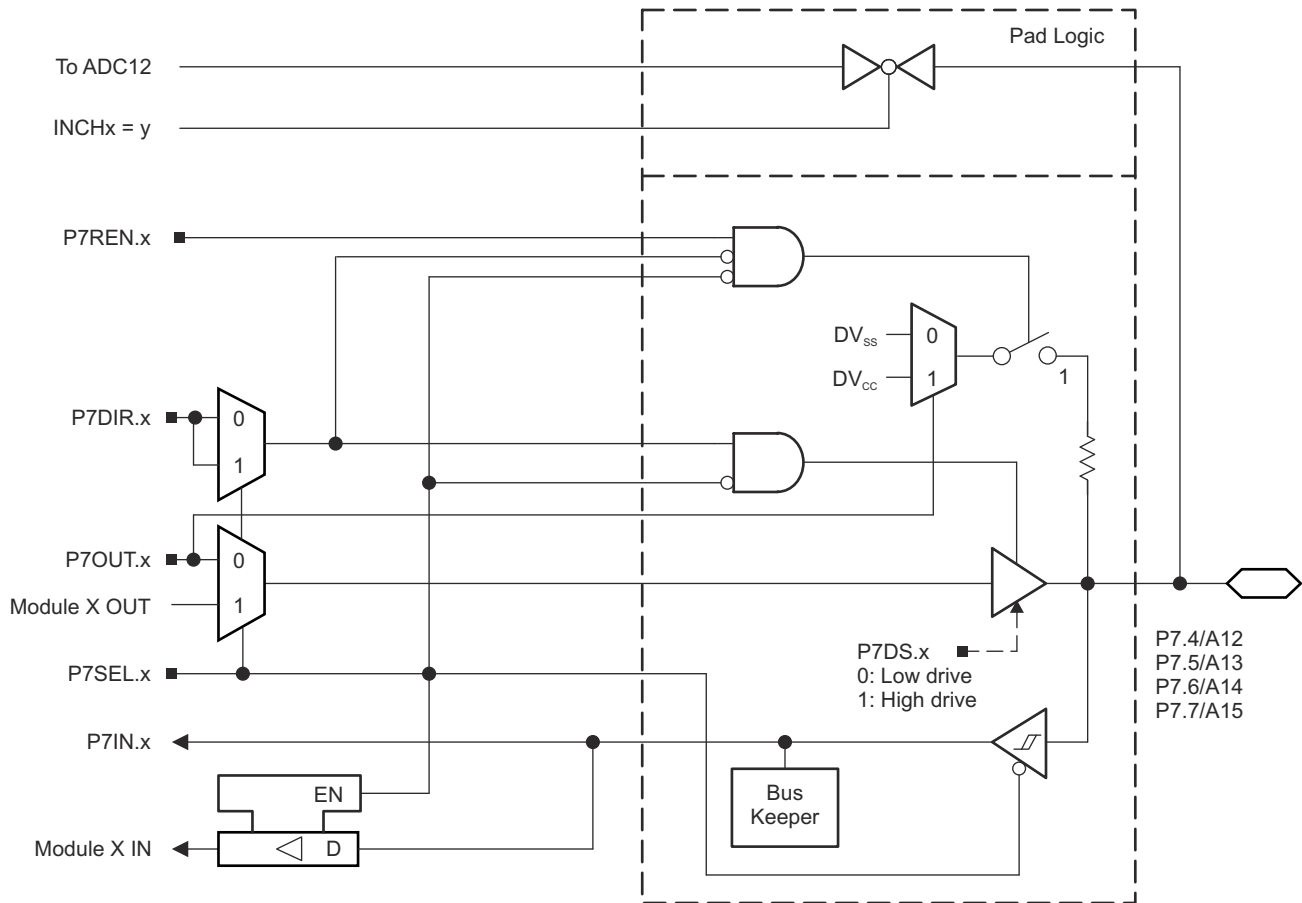

Figure 9-14. Port P7 (P7.4 to P7.7) Diagram

Table 9-53. Port P7 (P7.4 to P7.7) Pin Functions

PIN NAME (P7.x)	x	FUNCTION	CONTROL BITS OR SIGNALS ⁽¹⁾		
			P7DIR.x	P7SEL.x	INCHx
P7.4/A12	4	P7.4 (I/O)	I: 0; O: 1	0	X
		A12 ^{(2) (3)}	X	X	12
P7.5/A13	5	P7.5 (I/O)	I: 0; O: 1	0	X
		A13 ^{(2) (3)}	X	X	13
P7.6/A14	6	P7.6 (I/O)	I: 0; O: 1	0	X
		A14 ^{(2) (3)}	X	X	14
P7.7/A15	7	P7.7 (I/O)	I: 0; O: 1	0	X
		A15 ^{(2) (3)}	X	X	15

- (1) X = Don't care
- (2) Setting the P7SEL.x bit disables the output driver and the input Schmitt trigger to prevent parasitic cross currents when applying analog signals.
- (3) The ADC12_A channel Ax is connected internally to AV_{SS} if not selected by the respective INCHx bits.

9.10.12 Port P8 (P8.0 to P8.7) Input/Output With Schmitt Trigger

Figure 9-15 shows the port diagram. Table 9-54 summarizes the selection of the pin functions.

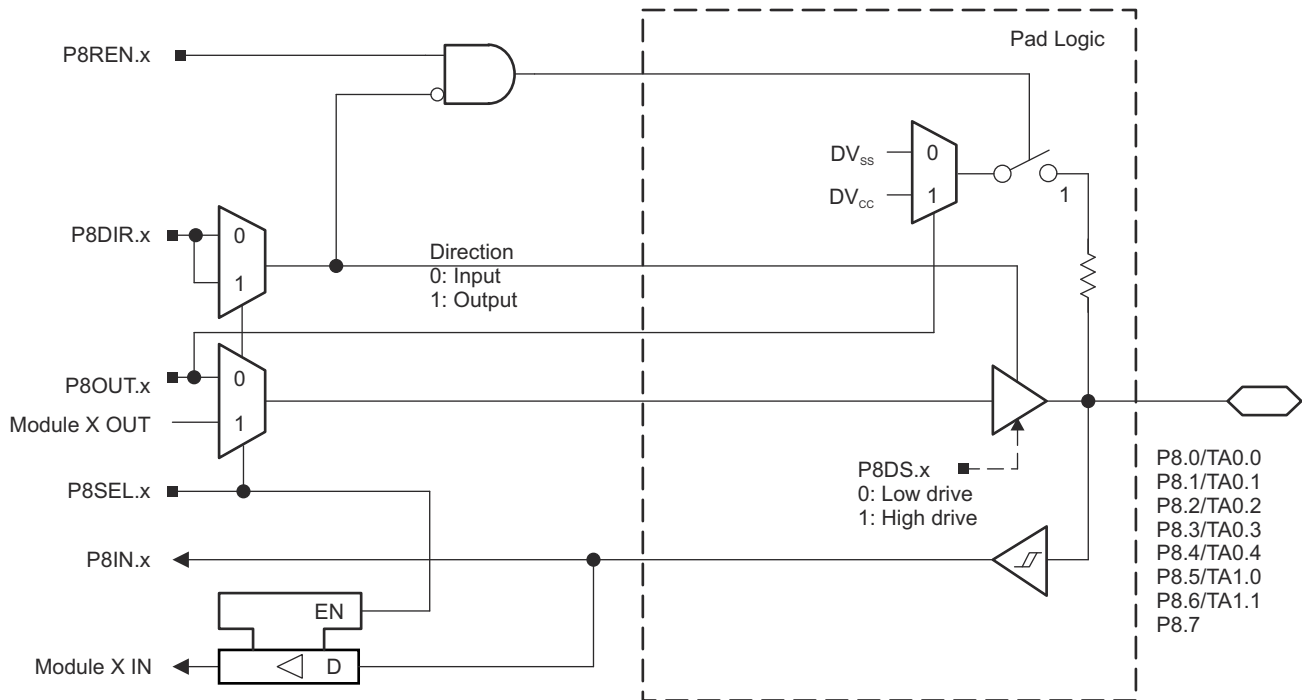

Figure 9-15. Port P8 (P8.0 to P8.7) Diagram

Table 9-54. Port P8 (P8.0 to P8.7) Pin Functions

PIN NAME (P8.x)	x	FUNCTION	CONTROL BITS OR SIGNALS	
			P8DIR.x	P8SEL.x
P8.0/TA0.0	0	P8.0 (I/O)	I: 0; O: 1	0
		TA0.CCI0B	0	1
		TA0.0	1	1
P8.1/TA0.1	1	P8.1 (I/O)	I: 0; O: 1	0
		TA0.CCI1B	0	1
		TA0.1	1	1
P8.2/TA0.2	2	P8.2 (I/O)	I: 0; O: 1	0
		TA0.CCI2B	0	1
		TA0.2	1	1
P8.3/TA0.3	3	P8.3 (I/O)	I: 0; O: 1	0
		TA0.CCI3B	0	1
		TA0.3	1	1
P8.4/TA0.4	4	P8.4 (I/O)	I: 0; O: 1	0
		TA0.CCI4B	0	1
		TA0.4	1	1
P8.5/TA1.0	5	P8.5 (I/O)	I: 0; O: 1	0
		TA1.CCI0B	0	1
		TA1.0	1	1
P8.6/TA1.1	6	P8.6 (I/O)	I: 0; O: 1	0
		TA1.CCI1B	0	1
		TA1.1	1	1
P8.7	7	P8.7 (I/O)	I: 0; O: 1	0

9.10.15 Port P11 (P11.0 to P11.2) Input/Output With Schmitt Trigger

Figure 9-18 shows the port diagram. Table 9-57 summarizes the selection of the pin functions.

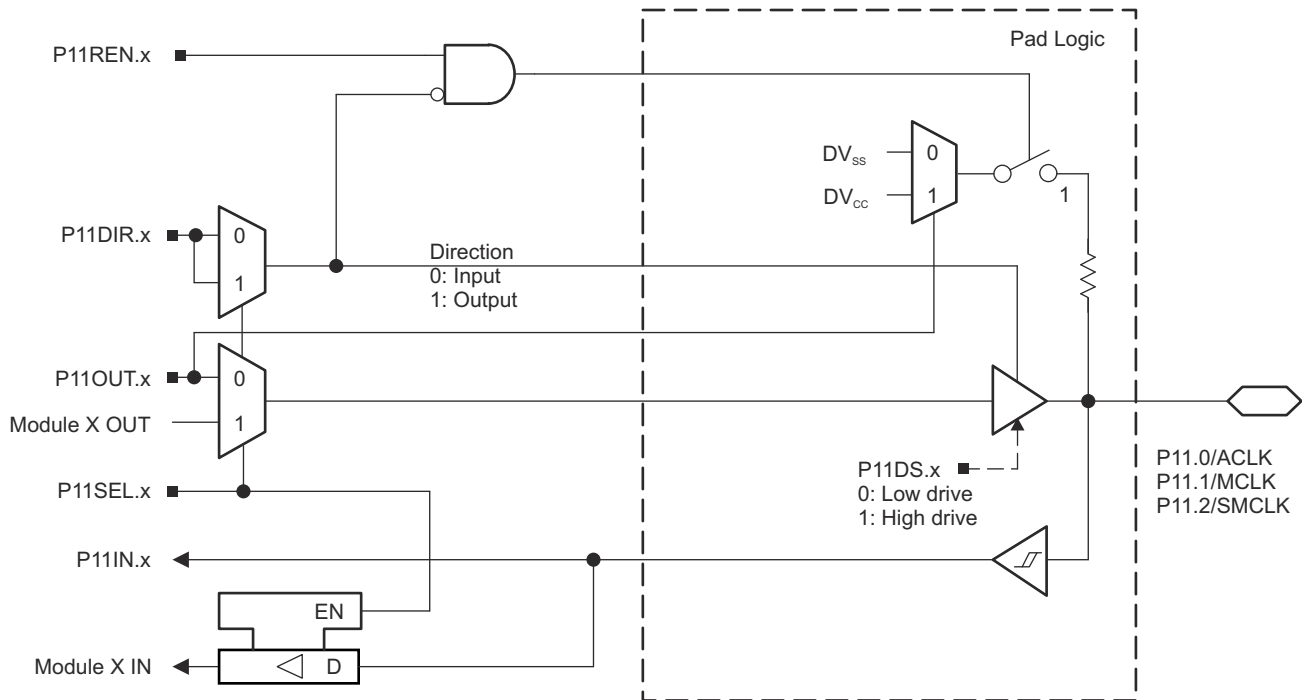

Figure 9-18. Port P11 (P11.0 to P11.2) Diagram

Table 9-57. Port P11 (P11.0 to P11.2) Pin Functions

PIN NAME (P11.x)	x	FUNCTION	CONTROL BITS OR SIGNALS	
			P11DIR.x	P11SEL.x
P11.0/ACLK	0	P11.0 (I/O)	I: 0; O: 1	0
		ACLK	1	1
P11.1/MCLK	1	P11.1 (I/O)	I: 0; O: 1	0
		MCLK	1	1
P11.2/SMCLK	2	P11.2 (I/O)	I: 0; O: 1	0
		SMCLK	1	1

9.10.16 Port PJ (PJ.0) JTAG Pin TDO, Input/Output With Schmitt Trigger or Output

Figure 9-19 shows the port diagram. Table 9-58 summarizes the selection of the pin functions.

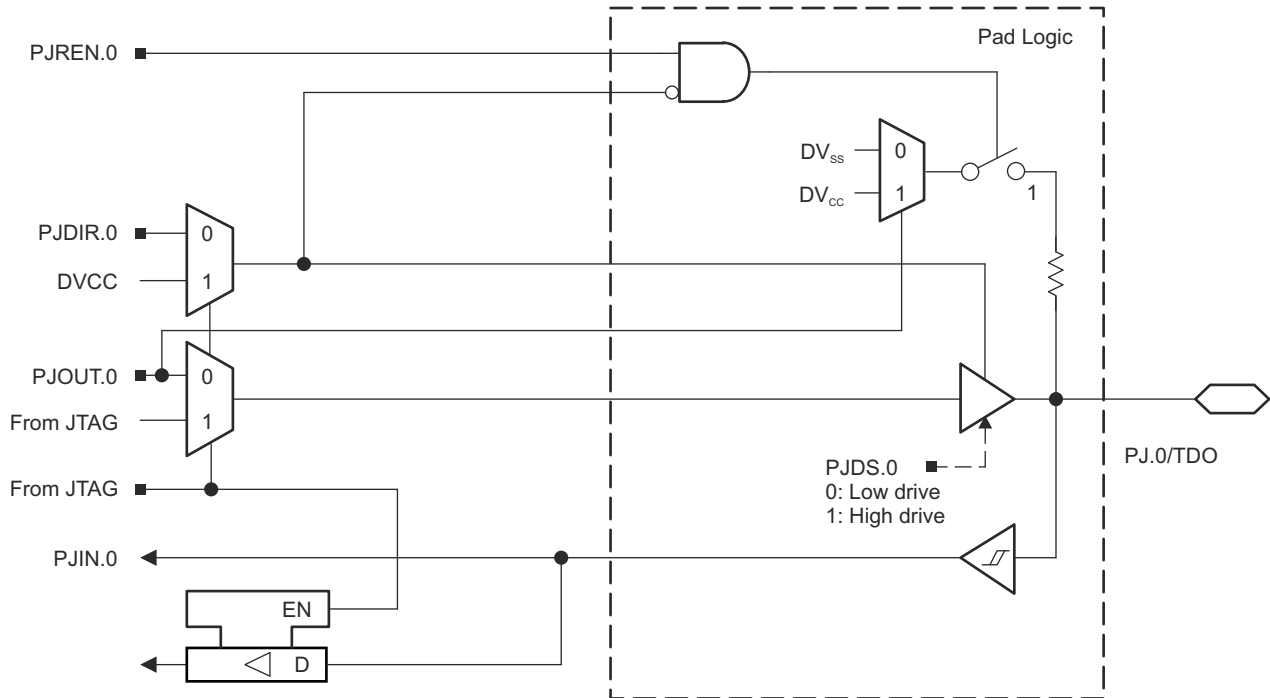

Figure 9-19. Port PJ (PJ.0) Diagram

9.10.17 Port PJ (PJ.1 to PJ.3) JTAG Pins TMS, TCK, TDI/TCLK, Input/Output With Schmitt Trigger or Output

Figure 9-20 shows the port diagram. Table 9-58 summarizes the selection of the pin functions.

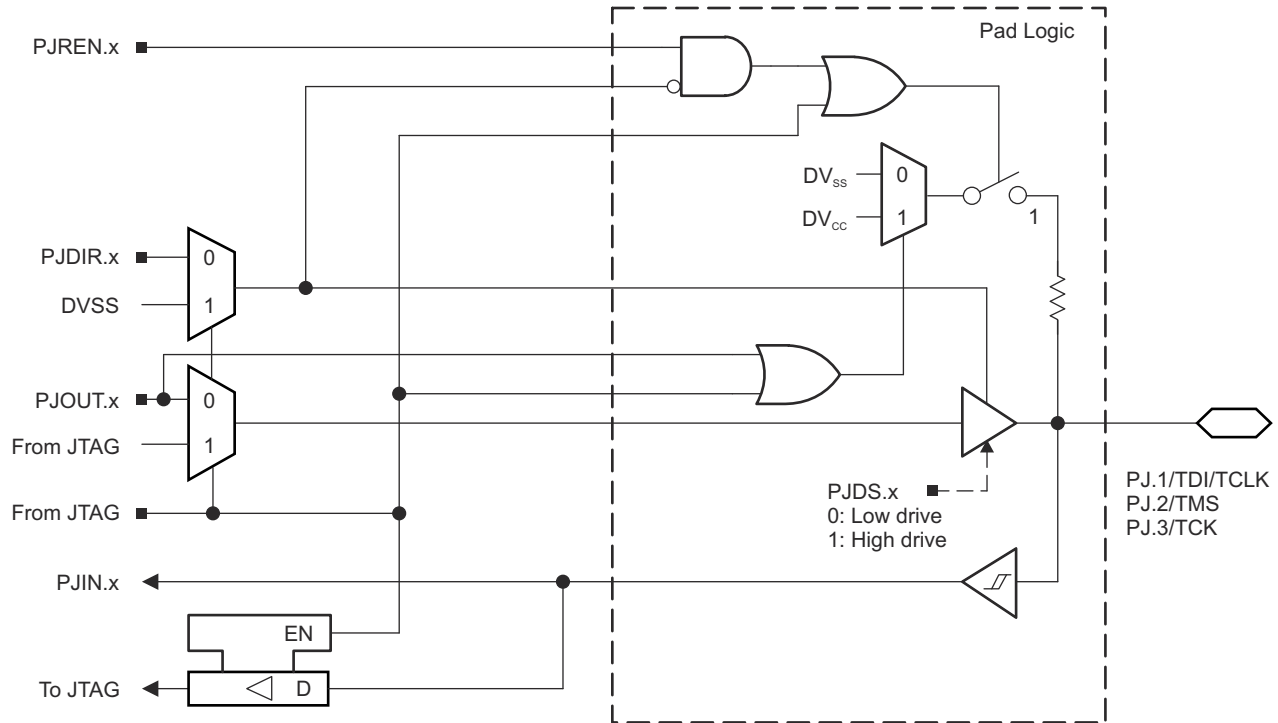

Figure 9-20. Port PJ (PJ.1 to PJ.3) Diagram

Table 9-58. Port PJ (PJ.0 to PJ.3) Pin Functions

PIN NAME (PJ.x)	x	FUNCTION	CONTROL BITS OR SIGNALS ⁽¹⁾
			PJDIR.x
PJ.0/TDO	0	PJ.0 (I/O) ⁽²⁾	I: 0; O: 1
		TDO ⁽³⁾	X
PJ.1/TDI/TCLK	1	PJ.1 (I/O) ⁽²⁾	I: 0; O: 1
		TDI/TCLK ^{(3) (4)}	X
PJ.2/TMS	2	PJ.2 (I/O) ⁽²⁾	I: 0; O: 1
		TMS ^{(3) (4)}	X
PJ.3/TCK	3	PJ.3 (I/O) ⁽²⁾	I: 0; O: 1
		TCK ^{(3) (4)}	X

- (1) X = Don't care
- (2) Default condition
- (3) The pin direction is controlled by the JTAG module.
- (4) In JTAG mode, pullups are activated automatically on TMS, TCK, and TDI/TCLK. PJREN.x are do not care.

9.11 Device Descriptors

Table 9-59 shows the contents of the device descriptor tag-length-value (TLV) structure for each device type.

Table 9-59. Device Descriptors

DESCRIPTION ⁽¹⁾	ADDRESS	SIZE (bytes)	VALUE						
			F5438A	F5437A	F5436A	F5435A	F5419A	F5418A	
Info Block	Info length	01A00h	1	06h	06h	06h	06h	06h	06h
	CRC length	01A01h	1	06h	06h	06h	06h	06h	06h
	CRC value	01A02h	2	Per unit	Per unit	Per unit	Per unit	Per unit	Per unit
	Device ID	01A04h	1	05h	04h	03h	02h	01h	00h
	Device ID	01A05h	1	80h	80h	80h	80h	80h	80h
	Hardware revision	01A06h	1	Per unit	Per unit	Per unit	Per unit	Per unit	Per unit
	Firmware revision	01A07h	1	Per unit	Per unit	Per unit	Per unit	Per unit	Per unit
Die Record	Die record tag	01A08h	1	08h	08h	08h	08h	08h	08h
	Die record length	01A09h	1	0Ah	0Ah	0Ah	0Ah	0Ah	0Ah
	Lot/wafer ID	01A0Ah	4	Per unit	Per unit	Per unit	Per unit	Per unit	Per unit
	Die X position	01A0Eh	2	Per unit	Per unit	Per unit	Per unit	Per unit	Per unit
	Die Y position	01A10h	2	Per unit	Per unit	Per unit	Per unit	Per unit	Per unit
	Test results	01A12h	2	Per unit	Per unit	Per unit	Per unit	Per unit	Per unit
ADC12 Calibration	ADC12 calibration tag	01A14h	1	11h	11h	11h	11h	11h	11h
	ADC12 calibration length	01A15h	1	10h	10h	10h	10h	10h	10h
	ADC gain factor	01A16h	2	Per unit	Per unit	Per unit	Per unit	Per unit	Per unit
	ADC offset	01A18h	2	Per unit	Per unit	Per unit	Per unit	Per unit	Per unit
	ADC 1.5-V reference Temperature sensor 30°C	01A1Ah	2	Per unit	Per unit	Per unit	Per unit	Per unit	Per unit
	ADC 1.5-V reference Temperature sensor 85°C	01A1Ch	2	Per unit	Per unit	Per unit	Per unit	Per unit	Per unit
	ADC 2.0-V reference Temperature sensor 30°C	01A1Eh	2	Per unit	Per unit	Per unit	Per unit	Per unit	Per unit
	ADC 2.0-V reference Temperature sensor 85°C	01A20h	2	Per unit	Per unit	Per unit	Per unit	Per unit	Per unit
	ADC 2.5-V reference Temperature sensor 30°C	01A22h	2	Per unit	Per unit	Per unit	Per unit	Per unit	Per unit
	ADC 2.5-V reference Temperature sensor 85°C	01A24h	2	Per unit	Per unit	Per unit	Per unit	Per unit	Per unit
REF Calibration	REF calibration tag	01A26h	1	12h	12h	12h	12h	12h	12h
	REF calibration length	01A27h	1	06h	06h	06h	06h	06h	06h
	REF 1.5-V reference	01A28h	2	Per unit	Per unit	Per unit	Per unit	Per unit	Per unit
	REF 2.0-V reference	01A2Ah	2	Per unit	Per unit	Per unit	Per unit	Per unit	Per unit
	REF 2.5-V reference	01A2Ch	2	Per unit	Per unit	Per unit	Per unit	Per unit	Per unit

Table 9-59. Device Descriptors (continued)

DESCRIPTION ⁽¹⁾	ADDRESS	SIZE (bytes)	VALUE						
			F5438A	F5437A	F5436A	F5435A	F5419A	F5418A	
Peripheral descriptor tag	01A2Eh	1	02h	02h	02h	02h	02h	02h	02h
Peripheral descriptor length	01A2Fh	1	61h	059h	62h	5Ah	61h	59h	59h
Memory 1		2	08h 8Ah	08h 8Ah	08h 8Ah	08h 8Ah	08h 8Ah	08h 8Ah	08h 8Ah
Memory 2		2	0Ch 86h	0Ch 86h	0Ch 86h	0Ch 86h	0Ch 86h	0Ch 86h	0Ch 86h
Memory 3		2	0Eh 30h	0Eh 30h	0Eh 30h	0Eh 30h	0Eh 30h	0Eh 30h	0Eh 30h
Memory 4		2	2Eh 98h	2Eh 98h	2Eh 97h	2Eh 97h	2Eh 96h	2Eh 96h	2Eh 96h
Memory 5		0/1	N/A	N/A	94h	94h	N/A	N/A	N/A
Delimiter		1	00h	00h	00h	00h	00h	00h	00h
Peripheral count		1	21h	1Dh	21h	1Dh	21h	1Dh	1Dh
MSP430CPUXV2		2	00h 23h	00h 23h	00h 23h	00h 23h	00h 23h	00h 23h	00h 23h
SBW		2	00h 0Fh	00h 0Fh	00h 0Fh	00h 0Fh	00h 0Fh	00h 0Fh	00h 0Fh
EEM-8		2	00h 05h	00h 05h	00h 05h	00h 05h	00h 05h	00h 05h	00h 05h
TI BSL		2	00h FCh	00h FCh	00h FCh	00h FCh	00h FCh	00h FCh	00h FCh
Package		2	00h 1Fh	00h 1Fh	00h 1Fh	00h 1Fh	00h 1Fh	00h 1Fh	00h 1Fh
SFR		2	10h 41h	10h 41h	10h 41h	10h 41h	10h 41h	10h 41h	10h 41h
PMM		2	02h 30h	02h 30h	02h 30h	02h 30h	02h 30h	02h 30h	02h 30h
FCTL		2	02h 38h	02h 38h	02h 38h	02h 38h	02h 38h	02h 38h	02h 38h
CRC16 straight		2	01h 3Ch	01h 3Ch	01h 3Ch	01h 3Ch	01h 3Ch	01h 3Ch	01h 3Ch
CRC16 bit reversed		2	00h 3Dh	00h 3Dh	00h 3Dh	00h 3Dh	00h 3Dh	00h 3Dh	00h 3Dh
RAMCTL		2	00h 44h	00h 44h	00h 44h	00h 44h	00h 44h	00h 44h	00h 44h
WDT_A		2	00h 40h	00h 40h	00h 40h	00h 40h	00h 40h	00h 40h	00h 40h
UCS		2	01h 48h	01h 48h	01h 48h	01h 48h	01h 48h	01h 48h	01h 48h
SYS		2	02h 42h	02h 42h	02h 42h	02h 42h	02h 42h	02h 42h	02h 42h
REF		2	03h A0h	03h A0h	03h A0h	03h A0h	03h A0h	03h A0h	03h A0h
Port 1 and 2		2	05h 51h	05h 51h	05h 51h	05h 51h	05h 51h	05h 51h	05h 51h
Port 3 and 4		2	02h 52h	02h 52h	02h 52h	02h 52h	02h 52h	02h 52h	02h 52h
Port 5 and 6		2	02h 53h	02h 53h	02h 53h	02h 53h	02h 53h	02h 53h	02h 53h
Port 7 and 8		2	02h 54h	02h 54h	02h 54h	02h 54h	02h 54h	02h 54h	02h 54h
Port 9 and 10		2	02h 55h	N/A	02h 55h	N/A	02h 55h	N/A	N/A
Port 11 and 12		2	02h 56h	N/A	02h 56h	N/A	02h 56h	N/A	N/A

Peripheral
Descriptor

Table 9-59. Device Descriptors (continued)

DESCRIPTION ⁽¹⁾	ADDRESS	SIZE (bytes)	VALUE						
			F5438A	F5437A	F5436A	F5435A	F5419A	F5418A	
Peripheral Descriptor (continued)	JTAG		2	08h 5Fh	0Ch 5Fh	08h 5Fh	0Ch 5Fh	08h 5Fh	0Ch 5Fh
	TA0		2	02h 62h	02h 62h	02h 62h	02h 62h	02h 62h	02h 62h
	TA1		2	04h 61h	04h 61h	04h 61h	04h 61h	04h 61h	04h 61h
	TB0		2	04h 67h	04h 67h	04h 67h	04h 67h	04h 67h	04h 67h
	RTC		2	0Eh 68h	0Eh 68h	0Eh 68h	0Eh 68h	0Eh 68h	0Eh 68h
	MPY32		2	02h 85h	02h 85h	02h 85h	02h 85h	02h 85h	02h 85h
	DMA-3		2	04h 47h	04h 47h	04h 47h	04h 47h	04h 47h	04h 47h
	USCI_A and USCI_B		2	0Ch 90h	0Ch 90h	0Ch 90h	0Ch 90h	0Ch 90h	0Ch 90h
	USCI_A and USCI_B		2	04h 90h	04h 90h	04h 90h	04h 90h	04h 90h	04h 90h
	USCI_A and USCI_B		2	04h 90h	N/A	04h 90h	N/A	04h 90h	N/A
	USCI_A and USCI_B		2	04h 90h	N/A	04h 90h	N/A	04h 90h	N/A
	ADC12_A		2	08h D1h	10h D1h	08h D1h	10h D1h	08h D1h	10h D1h
Interrupts	TB0.CCIFG0		1	64h	64h	64h	64h	64h	64h
	TB0.CCIFG1..6		1	65h	65h	65h	65h	65h	65h
	WDTIFG		1	40h	40h	40h	40h	40h	40h
	USCI_A0		1	90h	90h	90h	90h	90h	90h
	USCI_B0		1	91h	91h	91h	91h	91h	91h
	ADC12_A		1	D0h	D0h	D0h	D0h	D0h	D0h
	TA0.CCIFG0		1	60h	60h	60h	60h	60h	60h
	TA0.CCIFG1..4		1	61h	61h	61h	61h	61h	61h
	USCI_A2		1	94h	01h	94h	01h	94h	01h
	USCI_B2		1	95h	01h	95h	01h	95h	01h
	DMA		1	46h	46h	46h	46h	46h	46h
	TA1.CCIFG0		1	62h	62h	62h	62h	62h	62h
	TA1.CCIFG1..2		1	63h	63h	63h	63h	63h	63h
	P1		1	50h	50h	50h	50h	50h	50h
	USCI_A1		1	92h	92h	92h	92h	92h	92h
	USCI_B1		1	93h	93h	93h	93h	93h	93h
	USCI_A3		1	96h	01h	96h	01h	96h	01h
	USCI_B3		1	97h	01h	97h	01h	97h	01h
	P2		1	51h	51h	51h	51h	51h	51h
	RTC_A		1	68h	68h	68h	68h	68h	68h
Delimiter		1	00h	00h	00h	00h	00h	00h	

(1) N/A = Not applicable

10 Device and Documentation Support

10.1 Getting Started

For an introduction to the MSP430™ family of devices and the tools and libraries that are available to help with your development, visit the [MSP430 ultra-low-power sensing & measurement MCUs overview](#).

10.2 Device Nomenclature

To designate the stages in the product development cycle, TI assigns prefixes to the part numbers of all MSP MCU devices. Each MSP MCU commercial family member has one of two prefixes: MSP or XMS. These prefixes represent evolutionary stages of product development from engineering prototypes (XMS) through fully qualified production devices (MSP).

XMS – Experimental device that is not necessarily representative of the final device's electrical specifications

MSP – Fully qualified production device

XMS devices are shipped against the following disclaimer:

"Developmental product is intended for internal evaluation purposes."

MSP devices have been characterized fully, and the quality and reliability of the device have been demonstrated fully. TI's standard warranty applies.

Predictions show that prototype devices (XMS) have a greater failure rate than the standard production devices. TI recommends that these devices not be used in any production system because their expected end-use failure rate still is undefined. Only qualified production devices are to be used.

TI device nomenclature also includes a suffix with the device family name. This suffix indicates the temperature range, package type, and distribution format. [Figure 10-1](#) provides a legend for reading the complete device name.

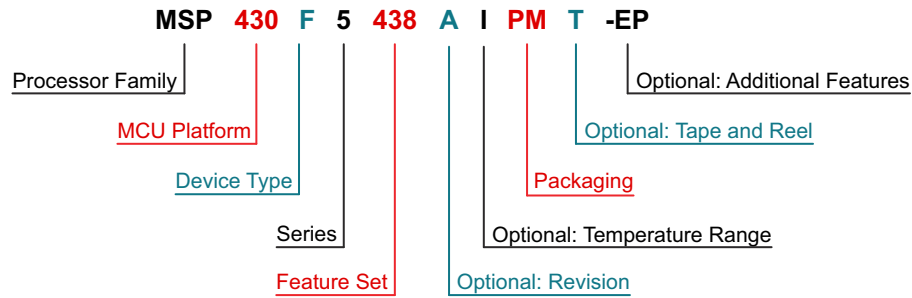

Processor Family	CC = Embedded RF Radio MSP = Mixed-Signal Processor XMS = Experimental Silicon PMS = Prototype Device		
MCU Platform	430 = MSP430 low-power microcontroller platform		
Device Type	<table border="0" style="width: 100%;"> <tr> <td style="vertical-align: top;">Memory Type C = ROM F = Flash FR = FRAM G = Flash L = No nonvolatile memory</td> <td style="vertical-align: top;">Specialized Application AFE = Analog front end BQ = Contactless power CG = ROM medical FE = Flash energy meter FG = Flash medical FW = Flash electronic flow meter</td> </tr> </table>	Memory Type C = ROM F = Flash FR = FRAM G = Flash L = No nonvolatile memory	Specialized Application AFE = Analog front end BQ = Contactless power CG = ROM medical FE = Flash energy meter FG = Flash medical FW = Flash electronic flow meter
Memory Type C = ROM F = Flash FR = FRAM G = Flash L = No nonvolatile memory	Specialized Application AFE = Analog front end BQ = Contactless power CG = ROM medical FE = Flash energy meter FG = Flash medical FW = Flash electronic flow meter		
Series	<table border="0" style="width: 100%;"> <tr> <td style="vertical-align: top;">1 = Up to 8 MHz 2 = Up to 16 MHz 3 = Legacy 4 = Up to 16 MHz with LCD driver</td> <td style="vertical-align: top;">5 = Up to 25 MHz 6 = Up to 25 MHz with LCD driver 0 = Low-voltage series</td> </tr> </table>	1 = Up to 8 MHz 2 = Up to 16 MHz 3 = Legacy 4 = Up to 16 MHz with LCD driver	5 = Up to 25 MHz 6 = Up to 25 MHz with LCD driver 0 = Low-voltage series
1 = Up to 8 MHz 2 = Up to 16 MHz 3 = Legacy 4 = Up to 16 MHz with LCD driver	5 = Up to 25 MHz 6 = Up to 25 MHz with LCD driver 0 = Low-voltage series		
Feature Set	Various levels of integration within a series		
Optional: Revision	Updated version of the base part number		
Optional: Temperature Range	S = 0°C to 50°C C = 0°C to 70°C I = -40°C to 85°C T = -40°C to 105°C		
Packaging	http://www.ti.com/packaging		
Optional: Tape and Reel	T = Small reel R = Large reel No markings = Tube or tray		
Optional: Additional Features	-EP = Enhanced product (-40°C to 105°C) -HT = Extreme temperature parts (-55°C to 150°C) -Q1 = Automotive Q100 qualified		

Figure 10-1. Device Nomenclature

10.3 Tools and Software

All MSP microcontrollers are supported by a wide variety of software and hardware development tools. Tools are available from TI and various third parties. See them all at [MSP430 Ultra-Low-Power MCUs – Tools & software](#).

Table 10-1 lists the debug features of the MSP430F543xA and MSP430F541xA MCUs. See the [Code Composer Studio IDE for MSP430 User's Guide](#) for details on the available features.

Table 10-1. Hardware Debug Features

MSP430 ARCHITECTURE	4-WIRE JTAG	2-WIRE JTAG	BREAK-POINTS (N)	RANGE BREAK-POINTS	CLOCK CONTROL	STATE SEQUENCER	TRACE BUFFER	LPMx.5 DEBUGGING SUPPORT
MSP430Xv2	Yes	Yes	8	Yes	Yes	Yes	Yes	No

Design Kits and Evaluation Modules

[MSP-TS430PZ5x100 - 100-pin Target Development Board for MSP430F5x MCUs](#)

The MSP-TS430PZ5X100 is a stand-alone ZIF socket target board used to program and debug the MSP430 MCU in-system through the JTAG interface or the Spy Bi-Wire (2-wire JTAG) protocol.

[100-pin Target Development Board and MSP-FET Programmer Bundle for MSP430F5x MCUs](#)

The MSP-FET430U5x100 is a powerful flash emulation tool (FET) that includes the hardware and software required to quickly begin application development on the MSP430 MCU. It includes a ZIF socket target board (MSP-TS430PZ5x100) and a USB debugging interface (MSP-FET) used to program and debug the MSP430 in-system through the JTAG interface or the Spy Bi-Wire (2-wire JTAG) protocol. The flash memory can be erased and programmed in seconds with only a few keystrokes, and since the MSP430 flash is ultra-low power, no external power supply is required.

[MSP430F5438 Experimenter Board](#)

The MSP430F5438 Experimenter Board (MSP-EXP430F5438) is a microcontroller development for highly integrated, high performance MSP430F5438 MCUs. It features a 100-pin socket which supports the MSP430F5438A and other devices with similar pinout. The socket allows for quick upgrades to newer devices or quick applications changes. It is compatible with many TI low-power RF wireless development kits such as the CC2520EMK. The Experimenter Board helps designers quickly learn and develop using the F5xx MCUs, which provide low power, more memory and leading integration for applications such as energy harvesting, wireless sensing and automatic metering infrastructure (AMI).

Software

[MSP430Ware™ Software](#)

MSP430Ware software is a collection of code examples, data sheets, and other design resources for all MSP430 devices delivered in a convenient package. In addition to providing a complete collection of existing MSP430 design resources, MSP430Ware software also includes a high-level API called MSP Driver Library. This library makes it easy to program MSP430 hardware. MSP430Ware software is available as a component of Code Composer Studio™ IDE or as a stand-alone package.

[MSP430F543xA, MSP430F541xA Code Examples](#)

C Code examples are available for every MSP device that configures each of the integrated peripherals for various application needs.

[MSP Driver Library](#)

Driver Library's abstracted API keeps you above the bits and bytes of the MSP430 hardware by providing easy-to-use function calls. Thorough documentation is delivered through a helpful API Guide, which includes details on each function call and the recognized parameters. Developers can use Driver Library functions to write complete projects with minimal overhead.

[MSP EnergyTrace™ Technology](#)

EnergyTrace technology for MSP430 microcontrollers is an energy-based code analysis tool that measures and displays the application's energy profile and helps to optimize it for ultra-low-power consumption.

[ULP \(Ultra-Low Power\) Advisor](#)

ULP Advisor™ software is a tool for guiding developers to write more efficient code to fully utilize the unique ultra-low power features of MSP and MSP432 microcontrollers. Aimed at both experienced and new microcontroller developers, ULP Advisor checks your code against a thorough ULP checklist to squeeze every last nano amp out of your application. At build time, ULP Advisor will provide notifications and remarks to highlight areas of your code that can be further optimized for lower power.

[IEC60730 Software Package](#)

The IEC60730 MSP430 software package was developed to be useful in assisting customers in complying with IEC 60730-1:2010 (Automatic Electrical Controls for Household and Similar Use – Part 1: General Requirements) for up to Class B products, which includes home appliances, arc detectors, power converters, power tools, e-bikes, and many others. The IEC60730 MSP430 software package can be embedded in customer applications running on MSP430s to help simplify the customer's certification efforts of functional safety-compliant consumer devices to IEC 60730-1:2010 Class B.

[Fixed Point Math Library for MSP](#)

The MSP IQmath and Qmath Libraries are a collection of highly optimized and high-precision mathematical functions for C programmers to seamlessly port a floating-point algorithm into fixed-point code on MSP430 and MSP432 devices. These routines are typically used in computationally intensive real-time applications where optimal execution speed, high accuracy, and ultra-low energy are critical. By using the IQmath and Qmath libraries, it is possible to achieve execution speeds considerably faster and energy consumption considerably lower than equivalent code written using floating-point math.

[Floating Point Math Library for MSP430](#)

Continuing to innovate in the low power and low cost microcontroller space, TI brings you MSPMATHLIB. Leveraging the intelligent peripherals of our devices, this floating point math library of scalar functions brings you up to 26x better performance. Mathlib is easy to integrate into your designs. This library is free and is integrated in both Code Composer Studio and IAR IDEs. Read the user's guide for an in depth look at the math library and relevant benchmarks.

Development Tools

[Code Composer Studio™ Integrated Development Environment for MSP Microcontrollers](#)

Code Composer Studio is an integrated development environment (IDE) that supports all MSP microcontroller devices. Code Composer Studio comprises a suite of embedded software utilities used to develop and debug embedded applications. It includes an optimizing C/C++ compiler, source code editor, project build environment, debugger, profiler, and many other features. The intuitive IDE provides a single user interface taking you through each step of the application development flow. Familiar utilities and interfaces allow users to get started faster than ever before. Code Composer Studio combines the advantages of the Eclipse software framework with advanced embedded debug capabilities from TI resulting in a compelling feature-rich development environment for embedded developers. When using CCS with an MSP MCU, a unique and powerful set of plugins and embedded software utilities are made available to fully leverage the MSP microcontroller.

[Command-Line Programmer](#)

MSP Flasher is an open-source shell-based interface for programming MSP microcontrollers through a FET programmer or eZ430 using JTAG or Spy-Bi-Wire (SBW) communication. MSP Flasher can download binary files (.txt or .hex) files directly to the MSP microcontroller without an IDE.

MSP MCU Programmer and Debugger

The MSP-FET is a powerful emulation development tool – often called a debug probe – which allows users to quickly begin application development on MSP low-power microcontrollers (MCU). Creating MCU software usually requires downloading the resulting binary program to the MSP device for validation and debugging. The MSP-FET provides a debug communication pathway between a host computer and the target MSP. Furthermore, the MSP-FET also provides a Backchannel UART connection between the computer's USB interface and the MSP UART. This affords the MSP programmer a convenient method for communicating serially between the MSP and a terminal running on the computer. It also supports loading programs (often called firmware) to the MSP target using the BSL (bootloader) through the UART and I²C communication protocols.

MSP-GANG Production Programmer

The MSP Gang Programmer is an MSP430 or MSP432 device programmer that can program up to eight identical MSP430 or MSP432 Flash or FRAM devices at the same time. The MSP Gang Programmer connects to a host PC using a standard RS-232 or USB connection and provides flexible programming options that allow the user to fully customize the process. The MSP Gang Programmer is provided with an expansion board, called the Gang Splitter, that implements the interconnections between the MSP Gang Programmer and multiple target devices. Eight cables are provided that connect the expansion board to eight target devices (through JTAG or Spy-Bi-Wire connectors). The programming can be done with a PC or as a stand-alone device. A PC-side graphical user interface is also available and is DLL-based.

10.4 Documentation Support

The following documents describe the MSP430F543xA and MSP430F541xA MCUs. Copies of these documents are available on the Internet at www.ti.com.

Receiving Notification of Document Updates

To receive notification of documentation updates—including silicon errata—go to the product folder for your device on ti.com (for example, [MSP430F5438A](http://ti.com)). In the upper right corner, click the "Alert me" button. This registers you to receive a weekly digest of product information that has changed (if any). For change details, check the revision history of any revised document.

Errata

[MSP430F5438A Device Erratasheet](#)

Describes the known exceptions to the functional specifications for all silicon revisions of this device.

[MSP430F5437A Device Erratasheet](#)

Describes the known exceptions to the functional specifications for all silicon revisions of this device.

[MSP430F5436A Device Erratasheet](#)

Describes the known exceptions to the functional specifications for all silicon revisions of this device.

[MSP430F5435A Device Erratasheet](#)

Describes the known exceptions to the functional specifications for all silicon revisions of this device.

[MSP430F5419A Device Erratasheet](#)

Describes the known exceptions to the functional specifications for all silicon revisions of this device.

[MSP430F5418A Device Erratasheet](#)

Describes the known exceptions to the functional specifications for all silicon revisions of this device.

User's Guides

[MSP430F5xx and MSP430F6xx Family User's Guide](#)

Detailed information on the modules and peripherals available in this device family.

[MSP430 Flash Device Bootloader \(BSL\) User's Guide](#)

The MSP430 bootloader (BSL) lets users communicate with embedded memory in the MSP430 microcontroller during the prototyping phase, final production, and in service. Both the programmable memory (flash memory) and the data memory (RAM) can be modified as required. Do not confuse the bootloader with the bootstrap loader programs found in some digital signal processors (DSPs) that automatically load program code (and data) from external memory to the internal memory of the DSP.

[MSP430 Programming With the JTAG Interface](#)

This document describes the functions that are required to erase, program, and verify the memory module of the MSP430 flash-based and FRAM-based microcontroller families using the JTAG communication port. In addition, it describes how to program the JTAG access security fuse that is available on all MSP430 devices. This document describes device access using both the standard 4-wire JTAG interface and the 2-wire JTAG interface, which is also referred to as Spy-Bi-Wire (SBW).

[MSP430 Hardware Tools User's Guide](#)

This manual describes the hardware of the TI MSP-FET430 Flash Emulation Tool (FET). The FET is the program development tool for the MSP430 ultra-low-power microcontroller. Both available interface types, the parallel port interface and the USB interface, are described.

Application Reports

[MSP430 32-kHz Crystal Oscillators](#)

Selection of the right crystal, correct load circuit, and proper board layout are important for a stable crystal oscillator. This application report summarizes crystal oscillator function and explains the parameters to select the correct crystal for MSP430 ultra-low-power operation. In addition, hints and examples for correct board layout are given. The document also contains detailed information on the possible oscillator tests to ensure stable oscillator operation in mass production.

[MSP430 System-Level ESD Considerations](#)

System-level ESD has become increasingly demanding with silicon technology scaling towards lower voltages and the need for designing cost-effective and ultra-low-power components. This application report addresses three different ESD topics to help board designers and OEMs understand and design robust system-level designs.

10.5 Support Resources

[TI E2E™ support forums](#) are an engineer's go-to source for fast, verified answers and design help — straight from the experts. Search existing answers or ask your own question to get the quick design help you need.

Linked content is provided "AS IS" by the respective contributors. They do not constitute TI specifications and do not necessarily reflect TI's views; see TI's [Terms of Use](#).

10.6 Trademarks

MicroStar Junior™, MSP430™, MSP430Ware™, Code Composer Studio™, EnergyTrace™, ULP Advisor™, TI E2E™ are trademarks of Texas Instruments.

All trademarks are the property of their respective owners.

10.7 Electrostatic Discharge Caution



This integrated circuit can be damaged by ESD. Texas Instruments recommends that all integrated circuits be handled with appropriate precautions. Failure to observe proper handling and installation procedures can cause damage.

ESD damage can range from subtle performance degradation to complete device failure. Precision integrated circuits may be more susceptible to damage because very small parametric changes could cause the device not to meet its published specifications.

10.8 Export Control Notice

Recipient agrees to not knowingly export or re-export, directly or indirectly, any product or technical data (as defined by the U.S., EU, and other Export Administration Regulations) including software, or any controlled product restricted by other applicable national regulations, received from disclosing party under nondisclosure obligations (if any), or any direct product of such technology, to any destination to which such export or re-export is restricted or prohibited by U.S. or other applicable laws, without obtaining prior authorization from U.S. Department of Commerce and other competent Government authorities to the extent required by those laws.

10.9 Glossary

[TI Glossary](#) This glossary lists and explains terms, acronyms, and definitions.

11 Mechanical, Packaging, and Orderable Information

The following pages include mechanical, packaging, and orderable information. This information is the most current data available for the designated devices. This data is subject to change without notice and revision of this document. For browser-based versions of this data sheet, refer to the left-hand navigation.

PACKAGING INFORMATION

Orderable Device	Status (1)	Package Type	Package Drawing	Pins	Package Qty	Eco Plan (2)	Lead finish/ Ball material (6)	MSL Peak Temp (3)	Op Temp (°C)	Device Marking (4/5)	Samples
MSP430F5418AIPN	ACTIVE	LQFP	PN	80	119	RoHS & Green	NIPDAU	Level-3-260C-168 HR	-40 to 85	M430F5418A	Samples
MSP430F5418AIPNR	ACTIVE	LQFP	PN	80	1000	RoHS & Green	NIPDAU	Level-3-260C-168 HR	-40 to 85	M430F5418A	Samples
MSP430F5419AIPZ	ACTIVE	LQFP	PZ	100	90	RoHS & Green	NIPDAU	Level-3-260C-168 HR	-40 to 85	M430F5419A	Samples
MSP430F5419AIPZR	ACTIVE	LQFP	PZ	100	1000	RoHS & Green	NIPDAU	Level-3-260C-168 HR	-40 to 85	M430F5419A	Samples
MSP430F5419AIZCAR	ACTIVE	NFBGA	ZCA	113	2500	RoHS & Green	SNAGCU	Level-3-260C-168 HR	-40 to 85	F5419A	Samples
MSP430F5419AIZCAT	ACTIVE	NFBGA	ZCA	113	250	RoHS & Green	SNAGCU	Level-3-260C-168 HR	-40 to 85	F5419A	Samples
MSP430F5435AIPN	ACTIVE	LQFP	PN	80	119	RoHS & Green	NIPDAU	Level-3-260C-168 HR	-40 to 85	M430F5435A	Samples
MSP430F5435AIPNR	ACTIVE	LQFP	PN	80	1000	RoHS & Green	NIPDAU	Level-3-260C-168 HR	-40 to 85	M430F5435A	Samples
MSP430F5436AIPZ	ACTIVE	LQFP	PZ	100	90	RoHS & Green	NIPDAU	Level-3-260C-168 HR	-40 to 85	M430F5436A	Samples
MSP430F5436AIPZR	ACTIVE	LQFP	PZ	100	1000	RoHS & Green	NIPDAU	Level-3-260C-168 HR	-40 to 85	M430F5436A	Samples
MSP430F5436AIZCAR	ACTIVE	NFBGA	ZCA	113	2500	RoHS & Green	SNAGCU	Level-3-260C-168 HR	-40 to 85	F5436A	Samples
MSP430F5436AIZCAT	ACTIVE	NFBGA	ZCA	113	250	RoHS & Green	SNAGCU	Level-3-260C-168 HR	-40 to 85	F5436A	Samples
MSP430F5437AIPN	ACTIVE	LQFP	PN	80	119	RoHS & Green	NIPDAU	Level-3-260C-168 HR	-40 to 85	M430F5437A	Samples
MSP430F5437AIPNR	ACTIVE	LQFP	PN	80	1000	RoHS & Green	NIPDAU	Level-3-260C-168 HR	-40 to 85	M430F5437A	Samples
MSP430F5438AIPZ	ACTIVE	LQFP	PZ	100	90	RoHS & Green	NIPDAU	Level-3-260C-168 HR	-40 to 85	M430F5438A	Samples
MSP430F5438AIPZR	ACTIVE	LQFP	PZ	100	1000	RoHS & Green	NIPDAU	Level-3-260C-168 HR	-40 to 85	M430F5438A	Samples
MSP430F5438AIZCAR	ACTIVE	NFBGA	ZCA	113	2500	RoHS & Green	SNAGCU	Level-3-260C-168 HR	-40 to 85	F5438A	Samples
MSP430F5438AIZCAT	ACTIVE	NFBGA	ZCA	113	250	RoHS & Green	SNAGCU	Level-3-260C-168 HR	-40 to 85	F5438A	Samples

⁽¹⁾ The marketing status values are defined as follows:

ACTIVE: Product device recommended for new designs.

LIFEBUY: TI has announced that the device will be discontinued, and a lifetime-buy period is in effect.

NRND: Not recommended for new designs. Device is in production to support existing customers, but TI does not recommend using this part in a new design.

PREVIEW: Device has been announced but is not in production. Samples may or may not be available.

OBSOLETE: TI has discontinued the production of the device.

⁽²⁾ **RoHS:** TI defines "RoHS" to mean semiconductor products that are compliant with the current EU RoHS requirements for all 10 RoHS substances, including the requirement that RoHS substance do not exceed 0.1% by weight in homogeneous materials. Where designed to be soldered at high temperatures, "RoHS" products are suitable for use in specified lead-free processes. TI may reference these types of products as "Pb-Free".

RoHS Exempt: TI defines "RoHS Exempt" to mean products that contain lead but are compliant with EU RoHS pursuant to a specific EU RoHS exemption.

Green: TI defines "Green" to mean the content of Chlorine (Cl) and Bromine (Br) based flame retardants meet JS709B low halogen requirements of <=1000ppm threshold. Antimony trioxide based flame retardants must also meet the <=1000ppm threshold requirement.

⁽³⁾ **MSL, Peak Temp.** - The Moisture Sensitivity Level rating according to the JEDEC industry standard classifications, and peak solder temperature.

⁽⁴⁾ There may be additional marking, which relates to the logo, the lot trace code information, or the environmental category on the device.

⁽⁵⁾ Multiple Device Markings will be inside parentheses. Only one Device Marking contained in parentheses and separated by a "~" will appear on a device. If a line is indented then it is a continuation of the previous line and the two combined represent the entire Device Marking for that device.

⁽⁶⁾ **Lead finish/Ball material** - Orderable Devices may have multiple material finish options. Finish options are separated by a vertical ruled line. Lead finish/Ball material values may wrap to two lines if the finish value exceeds the maximum column width.

Important Information and Disclaimer:The information provided on this page represents TI's knowledge and belief as of the date that it is provided. TI bases its knowledge and belief on information provided by third parties, and makes no representation or warranty as to the accuracy of such information. Efforts are underway to better integrate information from third parties. TI has taken and continues to take reasonable steps to provide representative and accurate information but may not have conducted destructive testing or chemical analysis on incoming materials and chemicals. TI and TI suppliers consider certain information to be proprietary, and thus CAS numbers and other limited information may not be available for release.

In no event shall TI's liability arising out of such information exceed the total purchase price of the TI part(s) at issue in this document sold by TI to Customer on an annual basis.

OTHER QUALIFIED VERSIONS OF MSP430F5438A :

- Enhanced Product : [MSP430F5438A-EP](#)

NOTE: Qualified Version Definitions:

- Enhanced Product - Supports Defense, Aerospace and Medical Applications

TAPE AND REEL INFORMATION

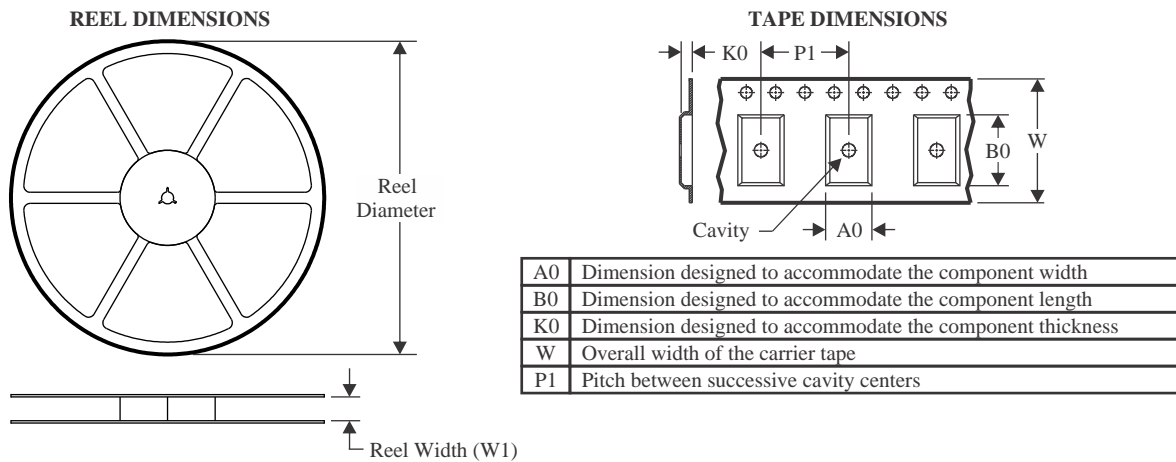

QUADRANT ASSIGNMENTS FOR PIN 1 ORIENTATION IN TAPE

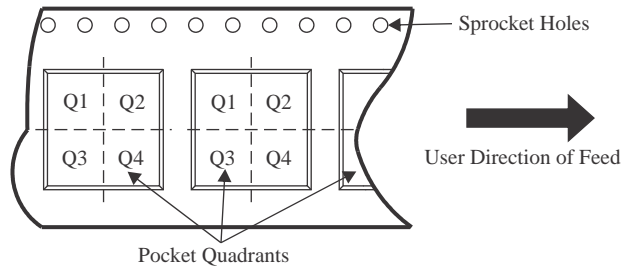

*All dimensions are nominal

Device	Package Type	Package Drawing	Pins	SPQ	Reel Diameter (mm)	Reel Width W1 (mm)	A0 (mm)	B0 (mm)	K0 (mm)	P1 (mm)	W (mm)	Pin1 Quadrant
MSP430F5418AIPNR	LQFP	PN	80	1000	330.0	24.4	15.0	15.0	2.1	20.0	24.0	Q2
MSP430F5419AIPZR	LQFP	PZ	100	1000	330.0	24.4	17.0	17.0	2.1	20.0	24.0	Q2
MSP430F5435AIPNR	LQFP	PN	80	1000	330.0	24.4	15.0	15.0	2.1	20.0	24.0	Q2
MSP430F5436AIPZR	LQFP	PZ	100	1000	330.0	24.4	17.0	17.0	2.1	20.0	24.0	Q2
MSP430F5437AIPNR	LQFP	PN	80	1000	330.0	24.4	15.0	15.0	2.1	20.0	24.0	Q2
MSP430F5438AIPZR	LQFP	PZ	100	1000	330.0	24.4	17.0	17.0	2.1	20.0	24.0	Q2

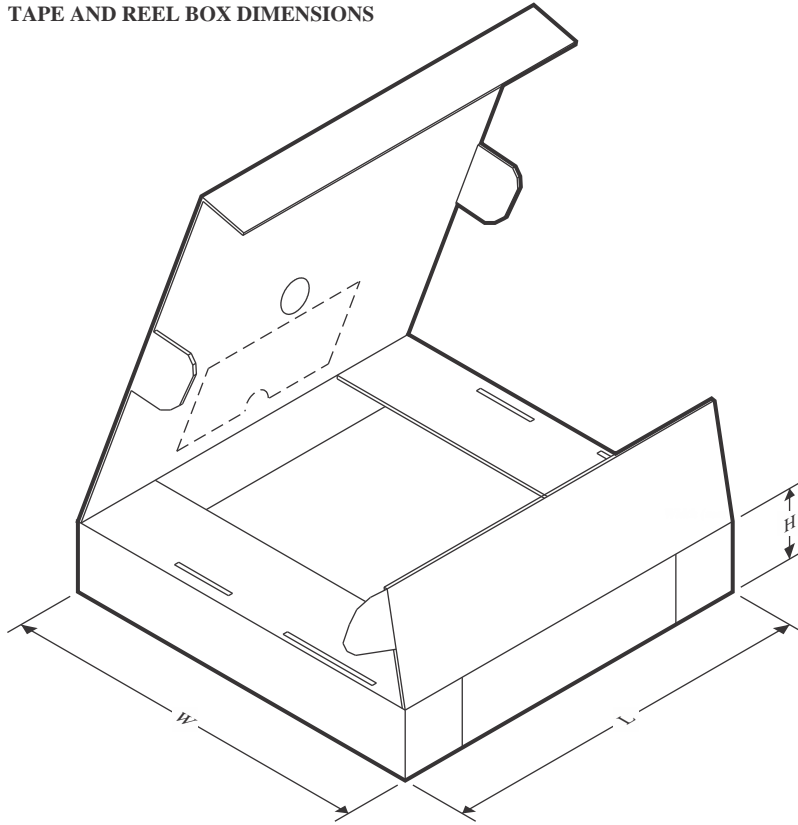
TAPE AND REEL BOX DIMENSIONS

*All dimensions are nominal

Device	Package Type	Package Drawing	Pins	SPQ	Length (mm)	Width (mm)	Height (mm)
MSP430F5418AIPNR	LQFP	PN	80	1000	350.0	350.0	43.0
MSP430F5419AIPZR	LQFP	PZ	100	1000	350.0	350.0	43.0
MSP430F5435AIPNR	LQFP	PN	80	1000	350.0	350.0	43.0
MSP430F5436AIPZR	LQFP	PZ	100	1000	350.0	350.0	43.0
MSP430F5437AIPNR	LQFP	PN	80	1000	350.0	350.0	43.0
MSP430F5438AIPZR	LQFP	PZ	100	1000	350.0	350.0	43.0

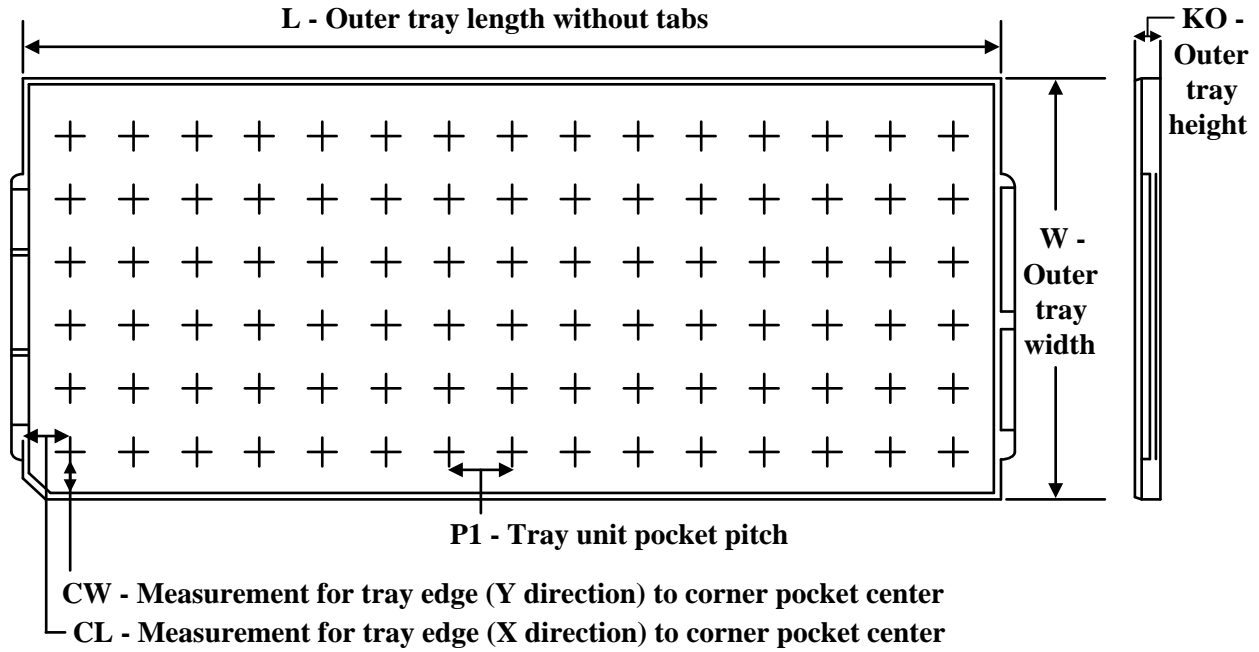
TRAY

Chamfer on Tray corner indicates Pin 1 orientation of packed units.

*All dimensions are nominal

Device	Package Name	Package Type	Pins	SPQ	Unit array matrix	Max temperature (°C)	L (mm)	W (mm)	K0 (µm)	P1 (mm)	CL (mm)	CW (mm)
MSP430F5418AIPN	PN	LQFP	80	119	7 x 17	150	315	135.9	7620	17.9	14.3	13.95
MSP430F5419AIPZ	PZ	LQFP	100	90	6 x 15	150	315	135.9	7620	20.3	15.4	15.45
MSP430F5419AIZCAT	ZCA	NFBGA	113	250	10 x 26	150	315	135.9	7620	11.8	10	10.35
MSP430F5435AIPN	PN	LQFP	80	119	7 x 17	150	315	135.9	7620	17.9	14.3	13.95
MSP430F5436AIPZ	PZ	LQFP	100	90	6 x 15	150	315	135.9	7620	20.3	15.4	15.45
MSP430F5436AIZCAT	ZCA	NFBGA	113	250	10 x 26	150	315	135.9	7620	11.8	10	10.35
MSP430F5437AIPN	PN	LQFP	80	119	7 x 17	150	315	135.9	7620	17.9	14.3	13.95
MSP430F5438AIPZ	PZ	LQFP	100	90	6 x 15	150	315	135.9	7620	20.3	15.4	15.45
MSP430F5438AIZCAT	ZCA	NFBGA	113	250	10 x 26	150	315	135.9	7620	11.8	10	10.35

PZ (S-PQFP-G100)

PLASTIC QUAD FLATPACK

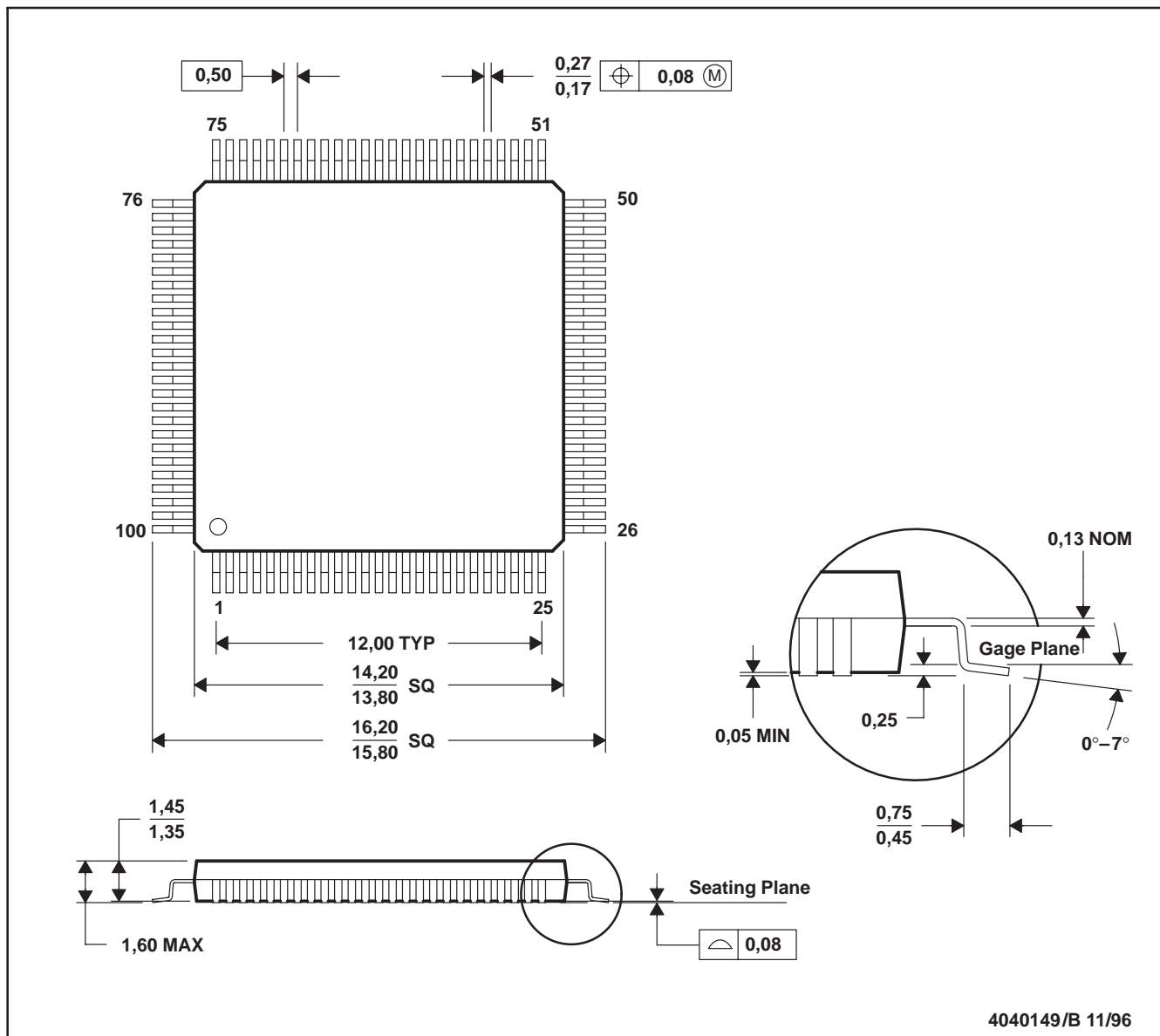

4040149/B 11/96

- NOTES: A. All linear dimensions are in millimeters.
 B. This drawing is subject to change without notice.
 C. Falls within JEDEC MS-026

PZ (S-PQFP-G100)

PLASTIC QUAD FLAT PACK

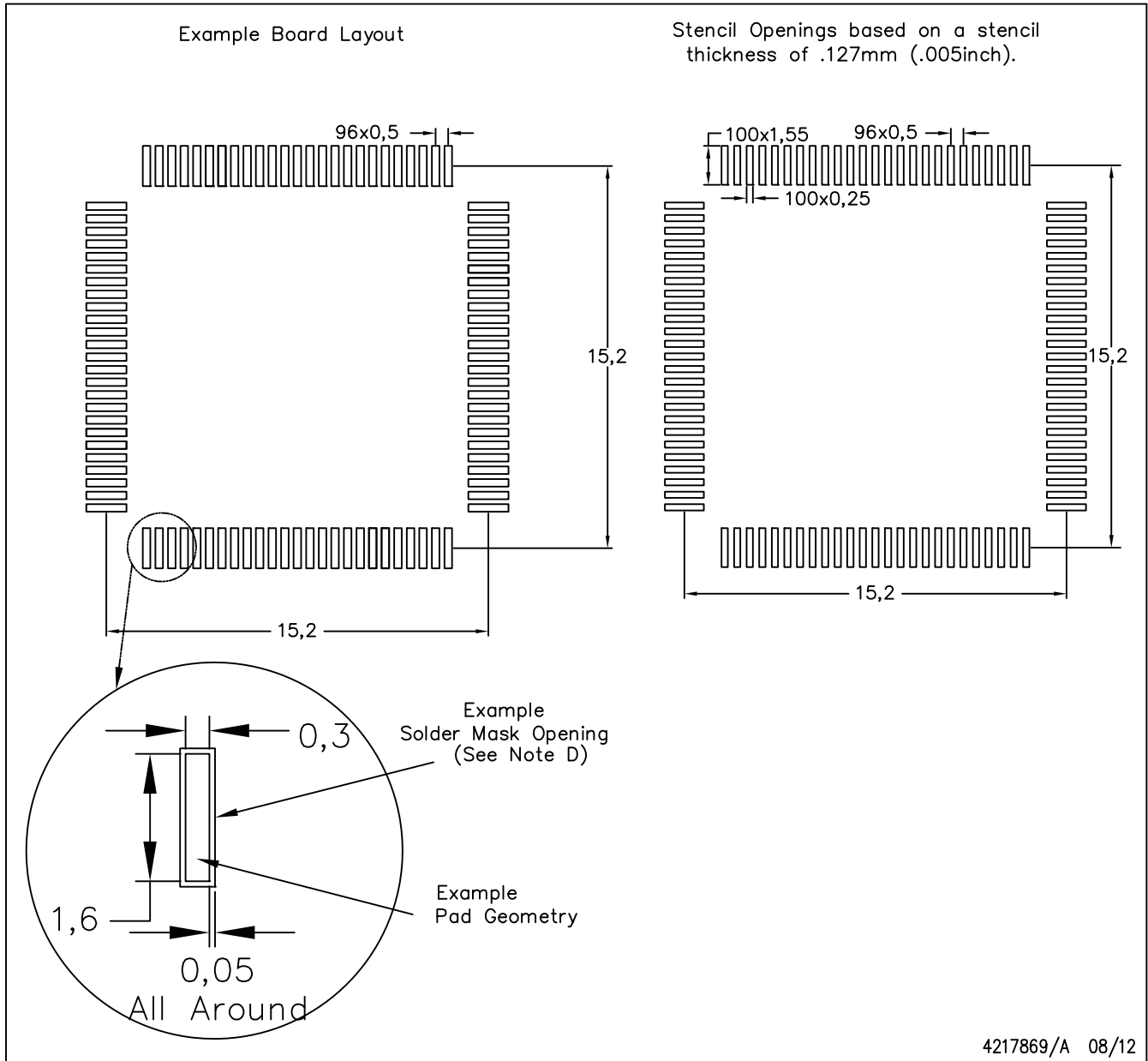

NOTES:

- All linear dimensions are in millimeters.
- This drawing is subject to change without notice.
- Laser cutting apertures with trapezoidal walls and also rounding corners will offer better paste release. Customers should contact their board assembly site for stencil design recommendations. Example stencil design based on a 50% volumetric metal load solder paste. Refer to IPC-7525 for other stencil recommendations.
- Customers should contact their board fabrication site for solder mask tolerances between and around signal pads.

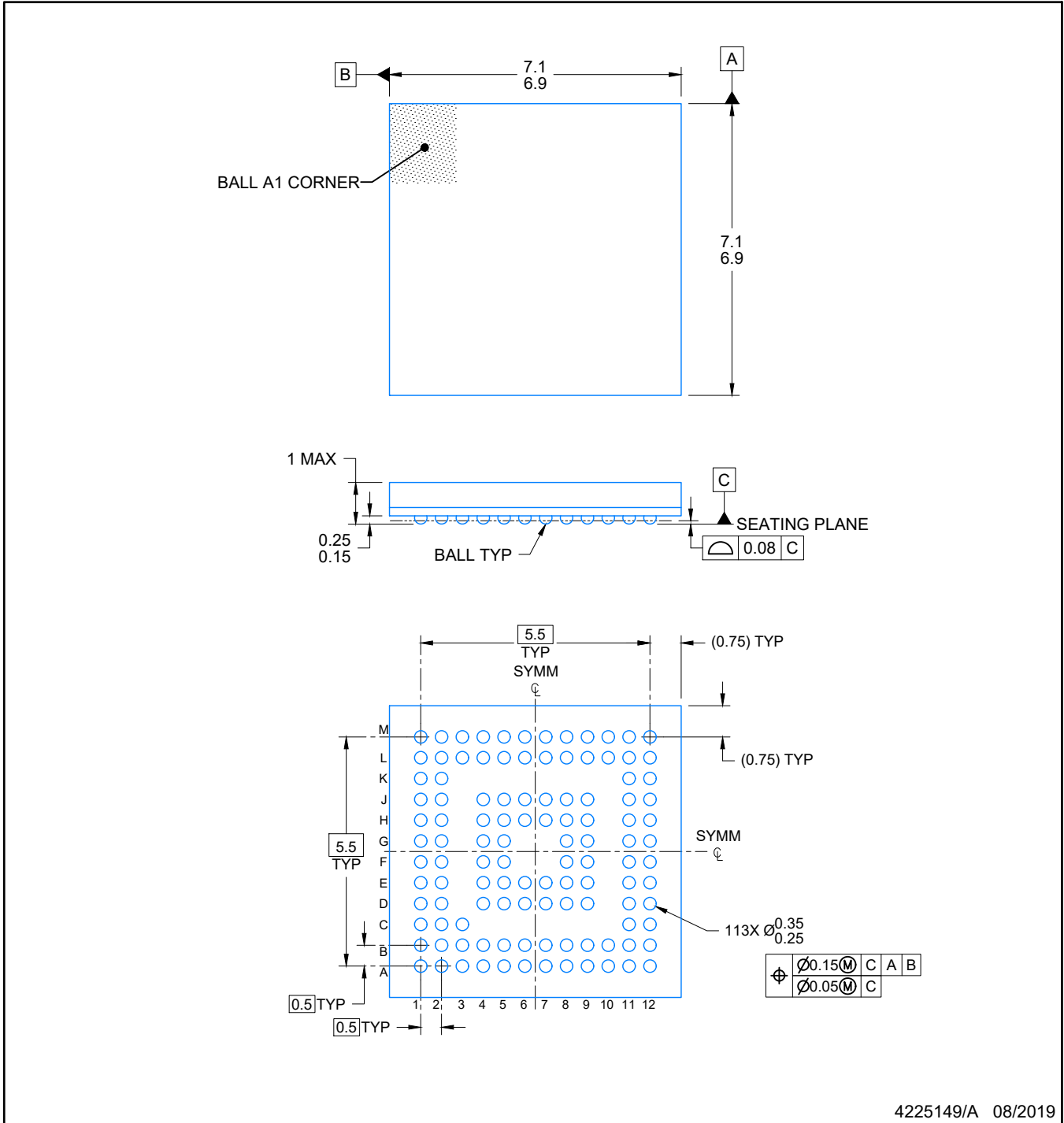

NOTES:

NanoFree is a trademark of Texas Instruments.

1. All linear dimensions are in millimeters. Any dimensions in parenthesis are for reference only. Dimensioning and tolerancing per ASME Y14.5M.
2. This drawing is subject to change without notice.

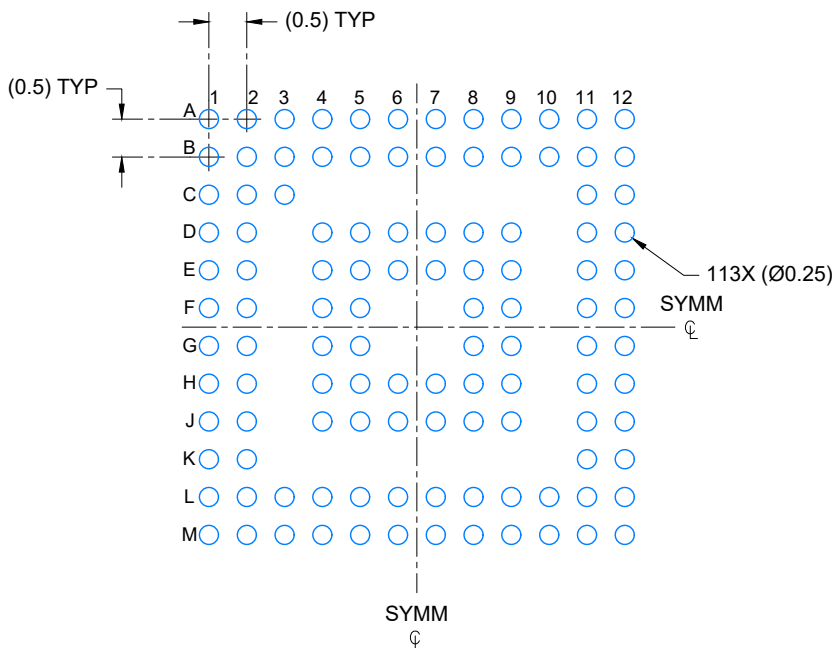

LAND PATTERN EXAMPLE
SCALE: 10X

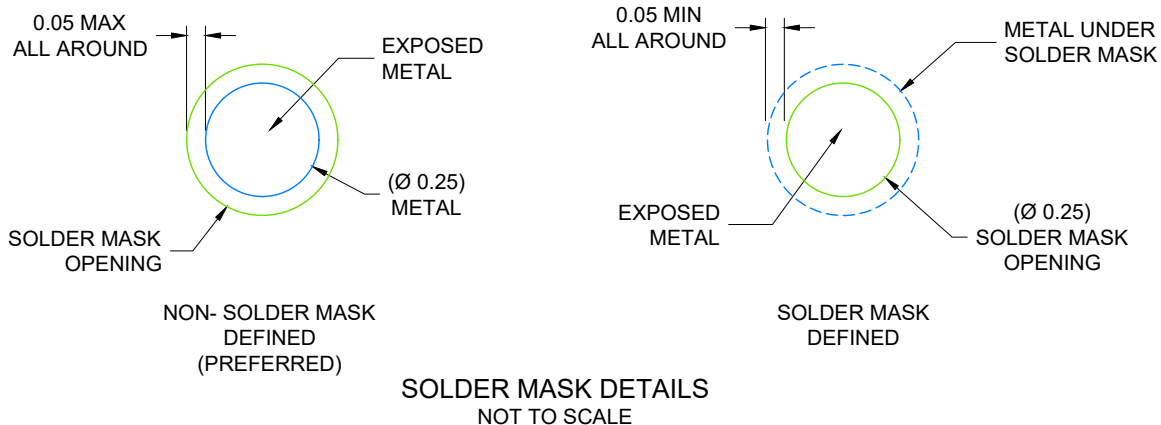

4225149/A 08/2019

NOTES: (continued)

- Final dimensions may vary due to manufacturing tolerance considerations and also routing constraints. Refer to Texas Instruments Literature number SNVA009 (www.ti.com/lit/snva009).

EXAMPLE STENCIL DESIGN

ZCA0113A

NFBGA - 1 mm max height

PLASTIC BALL GRID ARRAY

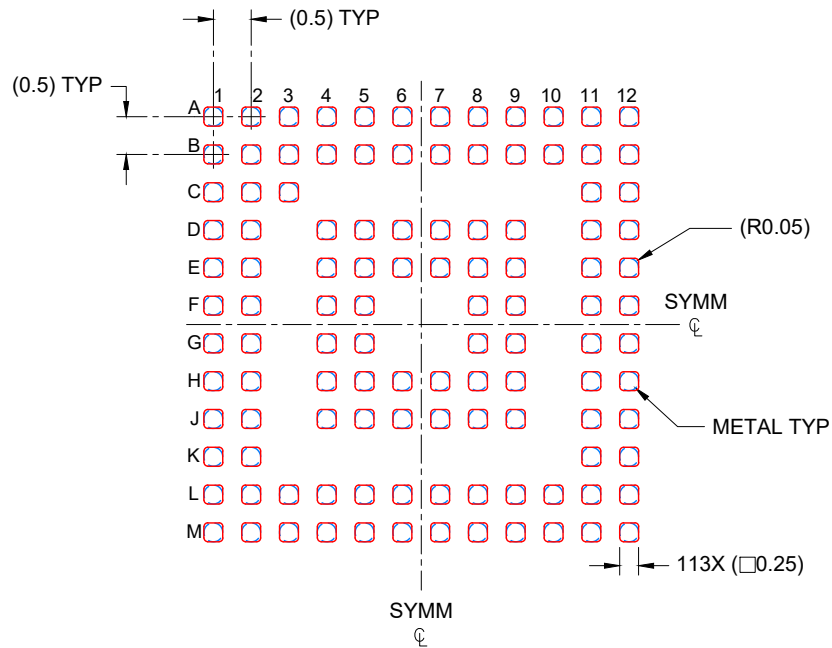

SOLDER PASTE EXAMPLE
BASED ON 0.100 mm THICK STENCIL
SCALE: 10X

4225149/A 08/2019

NOTES: (continued)

4. Laser cutting apertures with trapezoidal walls and rounded corners may offer better paste release.

PN0080A

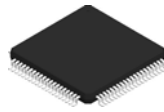

PACKAGE OUTLINE

LQFP - 1.6 mm max height

PLASTIC QUAD FLATPACK

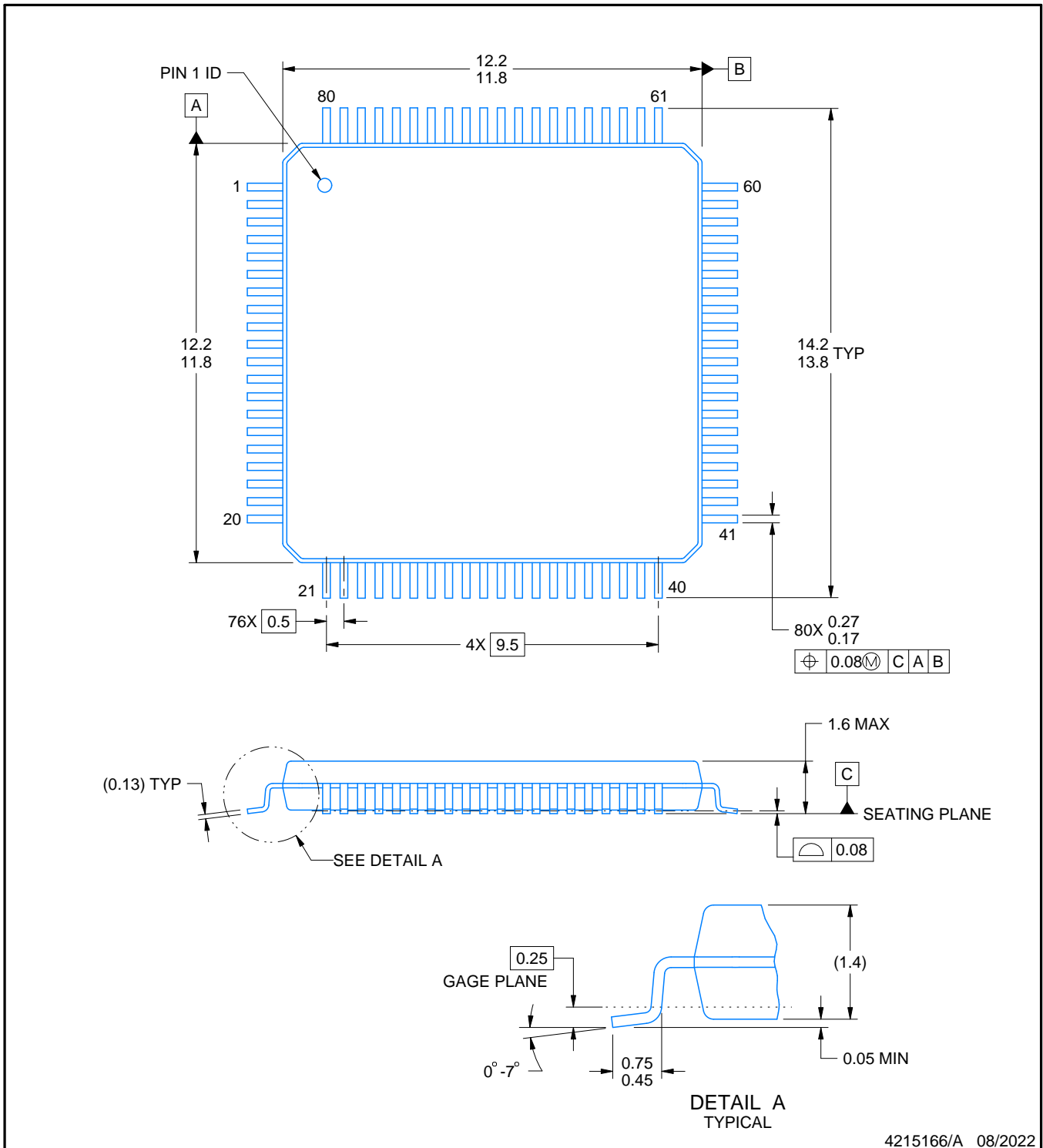

4215166/A 08/2022

NOTES:

1. All linear dimensions are in millimeters. Any dimensions in parenthesis are for reference only. Dimensioning and tolerancing per ASME Y14.5M.
2. This drawing is subject to change without notice.
3. Reference JEDEC registration MS-026.

EXAMPLE BOARD LAYOUT

PN0080A

LQFP - 1.6 mm max height

PLASTIC QUAD FLATPACK

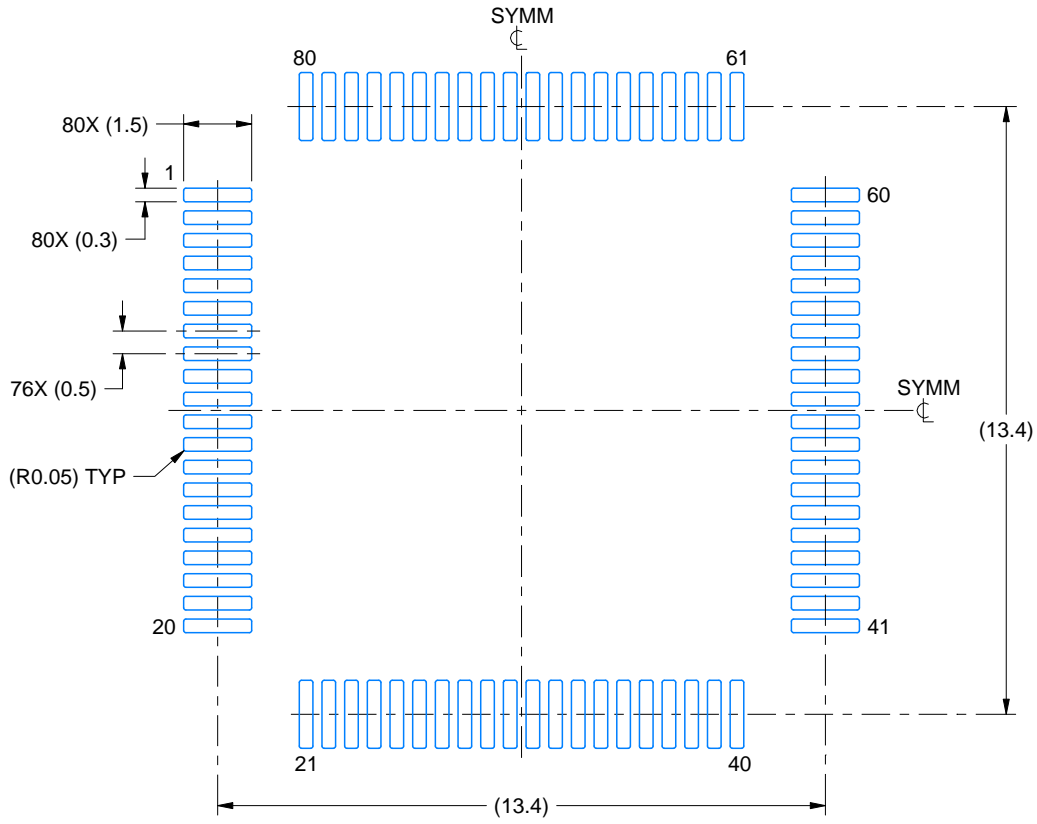

LAND PATTERN EXAMPLE
EXPOSED METAL SHOWN
SCALE:6X

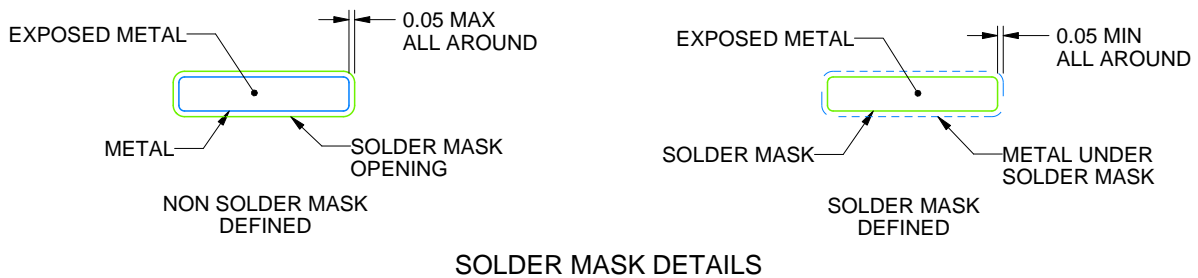

SOLDER MASK DETAILS

4215166/A 08/2022

NOTES: (continued)

4. Publication IPC-7351 may have alternate designs.
5. Solder mask tolerances between and around signal pads can vary based on board fabrication site.
6. For more information, see Texas Instruments literature number SLMA004 (www.ti.com/lit/slma004).

EXAMPLE STENCIL DESIGN

PN0080A

LQFP - 1.6 mm max height

PLASTIC QUAD FLATPACK

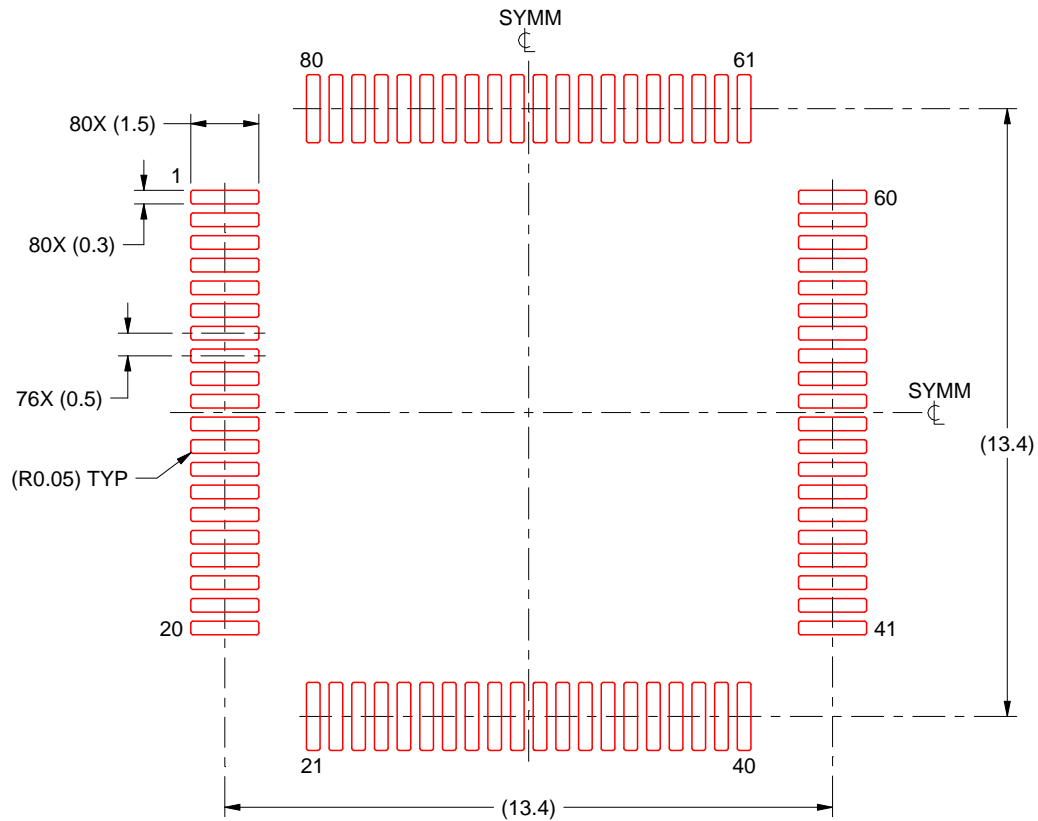

4215166/A 08/2022

NOTES: (continued)

7. Laser cutting apertures with trapezoidal walls and rounded corners may offer better paste release. IPC-7525 may have alternate design recommendations.
8. Board assembly site may have different recommendations for stencil design.

IMPORTANT NOTICE AND DISCLAIMER

TI PROVIDES TECHNICAL AND RELIABILITY DATA (INCLUDING DATA SHEETS), DESIGN RESOURCES (INCLUDING REFERENCE DESIGNS), APPLICATION OR OTHER DESIGN ADVICE, WEB TOOLS, SAFETY INFORMATION, AND OTHER RESOURCES "AS IS" AND WITH ALL FAULTS, AND DISCLAIMS ALL WARRANTIES, EXPRESS AND IMPLIED, INCLUDING WITHOUT LIMITATION ANY IMPLIED WARRANTIES OF MERCHANTABILITY, FITNESS FOR A PARTICULAR PURPOSE OR NON-INFRINGEMENT OF THIRD PARTY INTELLECTUAL PROPERTY RIGHTS.

These resources are intended for skilled developers designing with TI products. You are solely responsible for (1) selecting the appropriate TI products for your application, (2) designing, validating and testing your application, and (3) ensuring your application meets applicable standards, and any other safety, security, regulatory or other requirements.

These resources are subject to change without notice. TI grants you permission to use these resources only for development of an application that uses the TI products described in the resource. Other reproduction and display of these resources is prohibited. No license is granted to any other TI intellectual property right or to any third party intellectual property right. TI disclaims responsibility for, and you will fully indemnify TI and its representatives against, any claims, damages, costs, losses, and liabilities arising out of your use of these resources.

TI's products are provided subject to [TI's Terms of Sale](#) or other applicable terms available either on [ti.com](https://www.ti.com) or provided in conjunction with such TI products. TI's provision of these resources does not expand or otherwise alter TI's applicable warranties or warranty disclaimers for TI products.

TI objects to and rejects any additional or different terms you may have proposed.

Mailing Address: Texas Instruments, Post Office Box 655303, Dallas, Texas 75265
Copyright © 2024, Texas Instruments Incorporated

Looking for pricing, stock, or lifecycle information?

Click below to explore more details on WIN SOURCE:

 [View MSP430F5438AIZQWT on WIN SOURCE](#)

 [Texas Instruments](#) Information

Optimize Your Supply Chain with WIN SOURCE Solutions

-  Global Sourcing Solution
-  Obsolete Management
-  Cost Control Management
-  Shortage Management
-  Alternative Solution
-  Excess Inventory Management