



**THE DATASHEET OF**  
**2N3902**



## NPN HIGH POWER SILICON TRANSISTOR

Qualified per MIL-PRF-19500/371

### Devices

2N3902

2N5157

### Qualified Level

JAN  
JANTX

### MAXIMUM RATINGS

Ratings	Symbol	2N3902	2N5157	Unit
Collector-Emitter Voltage	$V_{CEO}$	400	500	Vdc
Emitter-Base Voltage	$V_{EBO}$	5.0	6.0	Vdc
Collector-Base Voltage	$V_{CBO}$	700		Vdc
Base Current	$I_B$	2.0		Adc
Collector Current	$I_C$	3.5		Adc
Total Power Dissipation	$P_T$	@ $T_A = +25^{\circ}C$ <sup>(1)</sup>	5.0	W
		@ $T_C = +75^{\circ}C$ <sup>(2)</sup>	100	W
Operating & Storage Temperature Range	$T_j, T_{stg}$	-65 to +200		$^{\circ}C$

### THERMAL CHARACTERISTICS

Characteristics	Symbol	Max.	Unit
Thermal Resistance, Junction-to-Case	$R_{\theta JC}$	1.25	$^{\circ}C/W$

1) Derate linearly 29 mW/ $^{\circ}C$  for  $T_A > +25^{\circ}C$

2) Derate linearly 0.8 W/ $^{\circ}C$  for  $T_C > +75^{\circ}C$

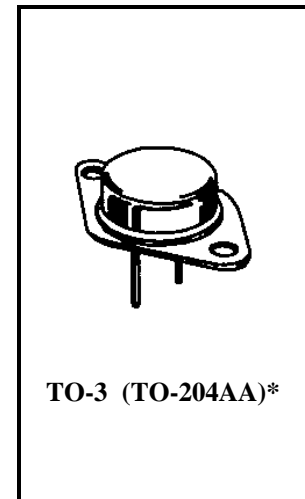

\*See Appendix A for Package Outline

### ELECTRICAL CHARACTERISTICS

Characteristics	Symbol	Min.	Max.	Unit
-----------------	--------	------	------	------

### OFF CHARACTERISTICS

Collector-Emitter Cutoff Current $V_{CE} = 325$ Vdc $V_{CE} = 400$ Vdc	2N3902 2N5157	$I_{CEO}$	250 250	$\mu$ Adc
Collector-Emitter Cutoff Current $V_{BE} = 1.5$ Vdc; $V_{CE} = 700$ Vdc		$I_{CEX}$	500	$\mu$ Adc
Emitter-Base Cutoff Current $V_{EB} = 5.0$ Vdc $V_{EB} = 6.0$ Vdc	2N3902 2N5157	$I_{EBO}$	200 200	$\mu$ Adc

### ON CHARACTERISTICS<sup>(3)</sup>

Base-Emitter Saturation Voltage $I_C = 1.0$ Adc; $I_B = 0.1$ Adc $I_C = 3.5$ Adc; $I_B = 0.7$ Adc		$V_{BE(sat)}$	1.5 2.0	Vdc
Collector-Emitter Saturation Voltage $I_C = 1.0$ Adc; $I_B = 0.1$ Adc $I_C = 3.5$ Adc; $I_B = 0.7$ Adc		$V_{CE(sat)}$	0.8 2.5	Vdc

**2N3902, 2N5157 JAN SERIES**

**ELECTRICAL CHARACTERISTICS (con't)**

Characteristics	Symbol	Min.	Max.	Unit
<b>ON CHARACTERISTICS<sup>(3)</sup> (con't)</b>				
Forward-Current Transfer Ratio I <sub>C</sub> = 0.5 Adc; V <sub>CE</sub> = 5.0 Vdc I <sub>C</sub> = 1.0 Adc; V <sub>CE</sub> = 5.0 Vdc I <sub>C</sub> = 2.5 Adc; V <sub>CE</sub> = 5.0 Vdc I <sub>C</sub> = 3.5 Adc; V <sub>CE</sub> = 5.0 Vdc	h <sub>FE</sub>	25 30 10 5	90	
Collector-Emitter Sustaining Voltage I <sub>C</sub> = 100 mAdc 2N3902 2N5157	V <sub>CEO(sus)</sub>	325 400		Vdc

**DYNAMIC CHARACTERISTICS**

Small-Signal Short-Circuit Forward Current Transfer Ratio I <sub>C</sub> = 0.2 Adc; V <sub>CE</sub> = 10 Vdc, f = 1 MHz	h <sub>fe</sub>	2.5	25	
Output Capacitance V <sub>CB</sub> = 10 Vdc; I <sub>E</sub> = 0, 100 kHz ≤ f ≤ 1.0 MHz	C <sub>obo</sub>		250	pF

**SWITCHING CHARACTERISTICS**

Turn-On Time V <sub>CC</sub> = 125 Vdc; I <sub>C</sub> = 1.0 Adc; I <sub>B1</sub> = 0.1 Adc	t <sub>on</sub>		0.8	μs
Turn-Off Time V <sub>CC</sub> = 125 Vdc; I <sub>C</sub> = 1.0 Adc; I <sub>B1</sub> = 0.1 Adc; -I <sub>B2</sub> = 0.50 Adc	t <sub>off</sub>		1.7	μs

**SAFE OPERATING AREA**

<b>DC Tests (continuous)</b>				
T <sub>C</sub> = +25°C; t ≥ 1.0 s (See Figure 3 of MIL-PRF-19500/371)				
<b>Test 1</b>				
V <sub>CE</sub> = 28.6 Vdc, I <sub>C</sub> = 3.5 Adc				
<b>Test 2</b>				
V <sub>CE</sub> = 70 Vdc, I <sub>C</sub> = 1.43 Adc				
<b>Test 3</b>				
V <sub>CE</sub> = 325 Vdc, I <sub>C</sub> = 55 mAdc	2N3902			
V <sub>CE</sub> = 400 Vdc, I <sub>C</sub> = 35 mAdc	2N5157			
<b>Switching Tests</b>				
<b>Load condition C (unclamped inductive load)</b>				
T <sub>C</sub> = 25°C; duty cycle ≤ 10%; R <sub>S</sub> = 0.1 Ω (See Figure 4 of MIL-PRF-19500/371)				
<b>Test 1</b>				
t <sub>p</sub> = approximately 3 ms (vary to obtain I <sub>C</sub> ); R <sub>BB1</sub> = 20 Ω; V <sub>BB1</sub> = 10 Vdc; R <sub>BB2</sub> = 3 kΩ; V <sub>BB2</sub> = 1.5 Vdc; V <sub>CC</sub> = 50 Vdc; I <sub>C</sub> = 3.5 Adc; L = 60 mH; R = 3 Ω; R <sub>L</sub> ≤ 14Ω.				
<b>Test 2</b>				
t <sub>p</sub> = approximately 3 ms (vary to obtain I <sub>C</sub> ); R <sub>BB1</sub> = 100 Ω; V <sub>BB1</sub> = 10 Vdc; R <sub>BB2</sub> = 3 kΩ; V <sub>BB2</sub> = 1.5 Vdc; I <sub>C</sub> = 0.6 Adc V <sub>CC</sub> = 50 Vdc; L = 200 mH; R = 8 Ω; R <sub>L</sub> ≤ 83Ω.				
<b>Switching Tests</b>				
<b>Load condition (clamped inductive load)</b>				
T <sub>C</sub> = +25°C; duty cycle ≤ 10%. (See Figure 5 of MIL-PRF-19500/371)				
<b>Test 1</b>				
t <sub>p</sub> = approximately 30 ms (vary to obtain I <sub>C</sub> ); R <sub>S</sub> = 0.1 Ω; R <sub>BB1</sub> = 20 Ω; V <sub>BB1</sub> = 10 Vdc; R <sub>BB2</sub> = 100 Ω; V <sub>BB2</sub> = 1.5 Vdc; V <sub>CC</sub> = 50 Vdc; I <sub>C</sub> = 3.5 Adc; L = 60 mH; R = 3 Ω; R <sub>L</sub> ≥ 0Ω. (A suitable clamping circuit or diode can be used.)				
Clamp Voltage = 400 +0, -5 Vdc	2N3902			
Clamp Voltage = 500 +0, -5 Vdc	2N5157			
(Clamped voltage must be reached)				

3.) Pulse Test: Pulse Width = 300μs, Duty Cycle ≤ 2.0%.

## Looking for pricing, stock, or lifecycle information?

Click below to explore more details on WIN SOURCE:

- ⊖ [View 2N3902 on WIN SOURCE](#)
- ⊖ [Microchip Technology](#) Information

## Optimize Your Supply Chain with WIN SOURCE Solutions

- ✓ Global Sourcing Solution
- ✓ Obsolete Management
- ✓ Cost Control Management
- ✓ Shortage Management
- ✓ Alternative Solution
- ✓ Excess Inventory Management