



**THE DATASHEET OF  
SN74ABTH18502APMR**





# SN54ABTH18502A, SN54ABTH182502A, SN74ABTH18502A, SN74ABTH182502A SCAN TEST DEVICES

## WITH 18-BIT UNIVERSAL BUS TRANSCEIVERS

SCBS164E – AUGUST 1993 – REVISED DECEMBER 1996

SN74ABTH18502A, SN74ABTH182502A . . . PM PACKAGE  
(TOP VIEW)

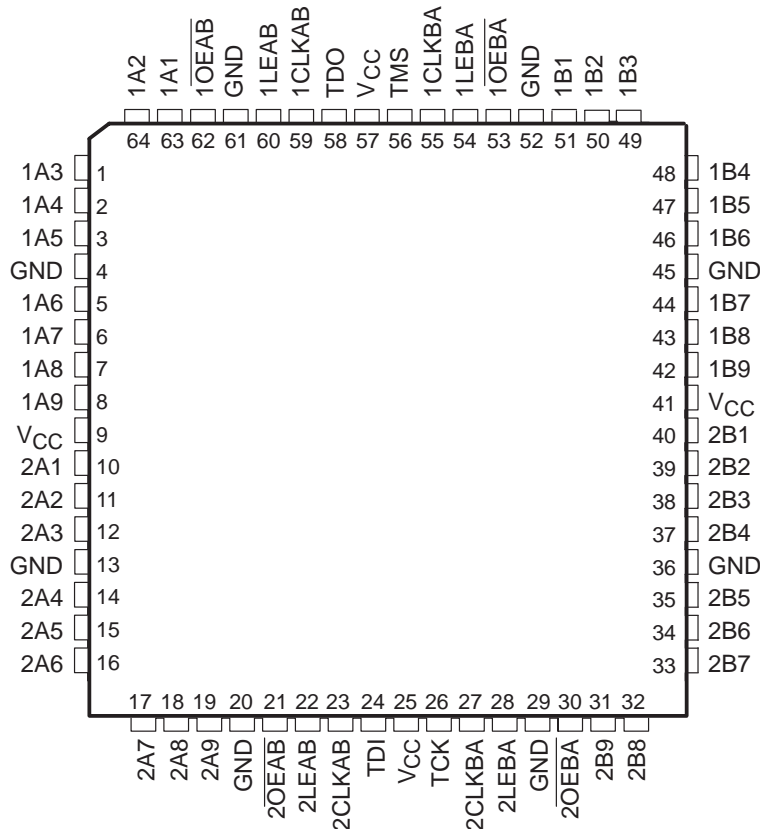

### description

The 'ABTH18502A and 'ABTH182502A scan test devices with 18-bit universal bus transceivers are members of the Texas Instruments SCOPE testability integrated-circuit family. This family of devices supports IEEE Standard 1149.1-1990 boundary scan to facilitate testing of complex circuit-board assemblies. Scan access to the test circuitry is accomplished via the 4-wire test access port (TAP) interface.

In the normal mode, these devices are 18-bit universal bus transceivers that combine D-type latches and D-type flip-flops to allow data flow in transparent, latched, or clocked modes. They can be used either as two 9-bit transceivers or one 18-bit transceiver. The test circuitry can be activated by the TAP to take snapshot samples of the data appearing at the device pins or to perform a self test on the boundary-test cells. Activating the TAP in the normal mode does not affect the functional operation of the SCOPE universal bus transceivers.

Data flow in each direction is controlled by output-enable ( $\overline{OEAB}$  and  $\overline{OEBA}$ ), latch-enable (LEAB and LEBA), and clock (CLKAB and CLKBA) inputs. For A-to-B data flow, the device operates in the transparent mode when LEAB is high. When LEAB is low, the A-bus data is latched while CLKAB is held at a static low or high logic level. Otherwise, if LEAB is low, A-bus data is stored on a low-to-high transition of CLKAB. When  $\overline{OEAB}$  is low, the B outputs are active. When  $\overline{OEAB}$  is high, the B outputs are in the high-impedance state. B-to-A data flow is similar to A-to-B data flow but uses the  $\overline{OEBA}$ , LEBA, and CLKBA inputs.

In the test mode, the normal operation of the SCOPE universal bus transceivers is inhibited and the test circuitry is enabled to observe and control the I/O boundary of the device. When enabled, the test circuitry performs boundary-scan test operations according to the protocol described in IEEE Standard 1149.1-1990.



POST OFFICE BOX 655303 • DALLAS, TEXAS 75265

**SN54ABTH18502A, SN54ABTH182502A, SN74ABTH18502A, SN74ABTH182502A**  
**SCAN TEST DEVICES**  
**WITH 18-BIT UNIVERSAL BUS TRANSCEIVERS**  
SCBS164E – AUGUST 1993 – REVISED DECEMBER 1996

**description (continued)**

Four dedicated test pins observe and control the operation of the test circuitry: test data input (TDI), test data output (TDO), test mode select (TMS), and test clock (TCK). Additionally, the test circuitry performs other testing functions such as parallel-signature analysis (PSA) on data inputs and pseudo-random pattern generation (PRPG) from data outputs. All testing and scan operations are synchronized to the TAP interface.

Improved scan efficiency is accomplished through the adoption of a one boundary-scan cell (BSC) per I/O pin architecture. This architecture is implemented in such a way as to capture the most pertinent test data. A PSA/COUNT instruction also is included to ease the testing of memories and other circuits where a binary count addressing scheme is useful.

Active bus-hold circuitry holds unused or floating data inputs at a valid logic level.

The B-port outputs of 'ABTH182502A, which are designed to source or sink up to 12 mA, include 25-Ω series resistors to reduce overshoot and undershoot.

The SN54ABTH18502A and SN54ABTH182502A are characterized for operation over the full military temperature range of –55°C to 125°C. The SN74ABTH18502A and SN74ABTH182502A are characterized for operation from –40°C to 85°C.

**FUNCTION TABLE†**  
(normal mode, each register)

INPUTS				OUTPUT
OEAB	LEAB	CLKAB	A	B
L	L	L	X	B <sub>0</sub> ‡
L	L	↑	L	L
L	L	↑	H	H
L	H	X	L	L
L	H	X	H	H
H	X	X	X	Z

† A-to-B data flow is shown. B-to-A data flow is similar but uses OEBA, LEBA, and CLKBA.

‡ Output level before the indicated steady-state input conditions were established

**SN54ABTH18502A, SN54ABTH182502A, SN74ABTH18502A, SN74ABTH182502A**  
**SCAN TEST DEVICES**  
**WITH 18-BIT UNIVERSAL BUS TRANSCEIVERS**  
 SCBS164E – AUGUST 1993 – REVISED DECEMBER 1996

**functional block diagram**

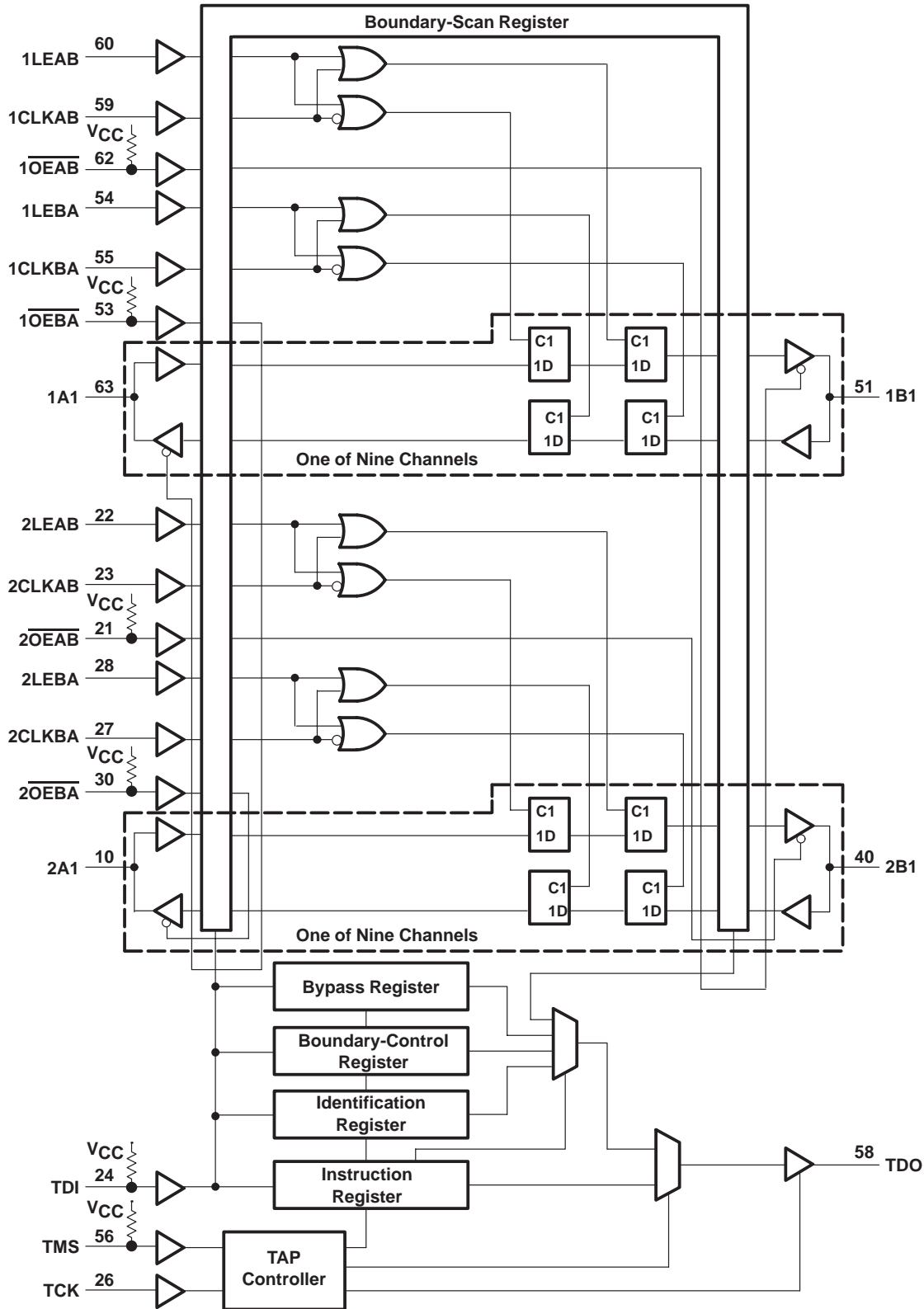

Pin numbers shown are for the PM package.



POST OFFICE BOX 655303 • DALLAS, TEXAS 75265

SN54ABTH18502A, SN54ABTH182502A, SN74ABTH18502A, SN74ABTH182502A  
**SCAN TEST DEVICES**  
**WITH 18-BIT UNIVERSAL BUS TRANSCEIVERS**  
SCBS164E – AUGUST 1993 – REVISED DECEMBER 1996

**Terminal Functions**

TERMINAL NAME	DESCRIPTION
1A1–1A9, 2A1–2A9	Normal-function A-bus I/O ports. See function table for normal-mode logic.
1B1–1B9, 2B1–2B9	Normal-function B-bus I/O ports. See function table for normal-mode logic.
1CLKAB, 1CLKBA, 2CLKAB, 2CLKBA	Normal-function clock inputs. See function table for normal-mode logic.
GND	Ground
1LEAB, 1LEBA, 2LEAB, 2LEBA	Normal-function latch enables. See function table for normal-mode logic.
$\overline{1OEAB}$ , $\overline{1OEBA}$ , $\overline{2OEAB}$ , $\overline{2OEBA}$	Normal-function output enables. See function table for normal-mode logic. An internal pullup at each terminal forces the terminal to a high level if left unconnected.
TCK	Test clock. One of four terminals required by IEEE Standard 1149.1-1990. Test operations of the device are synchronous to TCK. Data is captured on the rising edge of TCK and outputs change on the falling edge of TCK.
TDI	Test data input. One of four terminals required by IEEE Standard 1149.1-1990. TDI is the serial input for shifting data through the instruction register or selected data register. An internal pullup forces TDI to a high level if left unconnected.
TDO	Test data output. One of four terminals required by IEEE Standard 1149.1-1990. TDO is the serial output for shifting data through the instruction register or selected data register.
TMS	Test mode select. One of four terminals required by IEEE Standard 1149.1-1990. TMS directs the device through its TAP controller states. An internal pullup forces TMS to a high level if left unconnected.
VCC	Supply voltage

test architecture

Serial-test information is conveyed by means of a 4-wire test bus or TAP that conforms to IEEE Standard 1149.1-1990. Test instructions, test data, and test control signals all are passed along this serial-test bus. The TAP controller monitors two signals from the test bus, TCK and TMS. The TAP controller extracts the synchronization (TCK) and state control (TMS) signals from the test bus and generates the appropriate on-chip control signals for the test structures in the device. Figure 1 shows the TAP-controller state diagram.

The TAP controller is fully synchronous to the TCK signal. Input data is captured on the rising edge of TCK and output data changes on the falling edge of TCK. This scheme ensures that data to be captured is valid for fully one-half of the TCK cycle.

The functional block diagram illustrates the IEEE Standard 1149.1-1990 4-wire test bus and boundary-scan architecture and the relationship among the test bus, the TAP controller, and the test registers. As illustrated, the device contains an 8-bit instruction register and four test-data registers: a 48-bit boundary-scan register, a 3-bit boundary-control register, a 1-bit bypass register, and a 32-bit device-identification register.

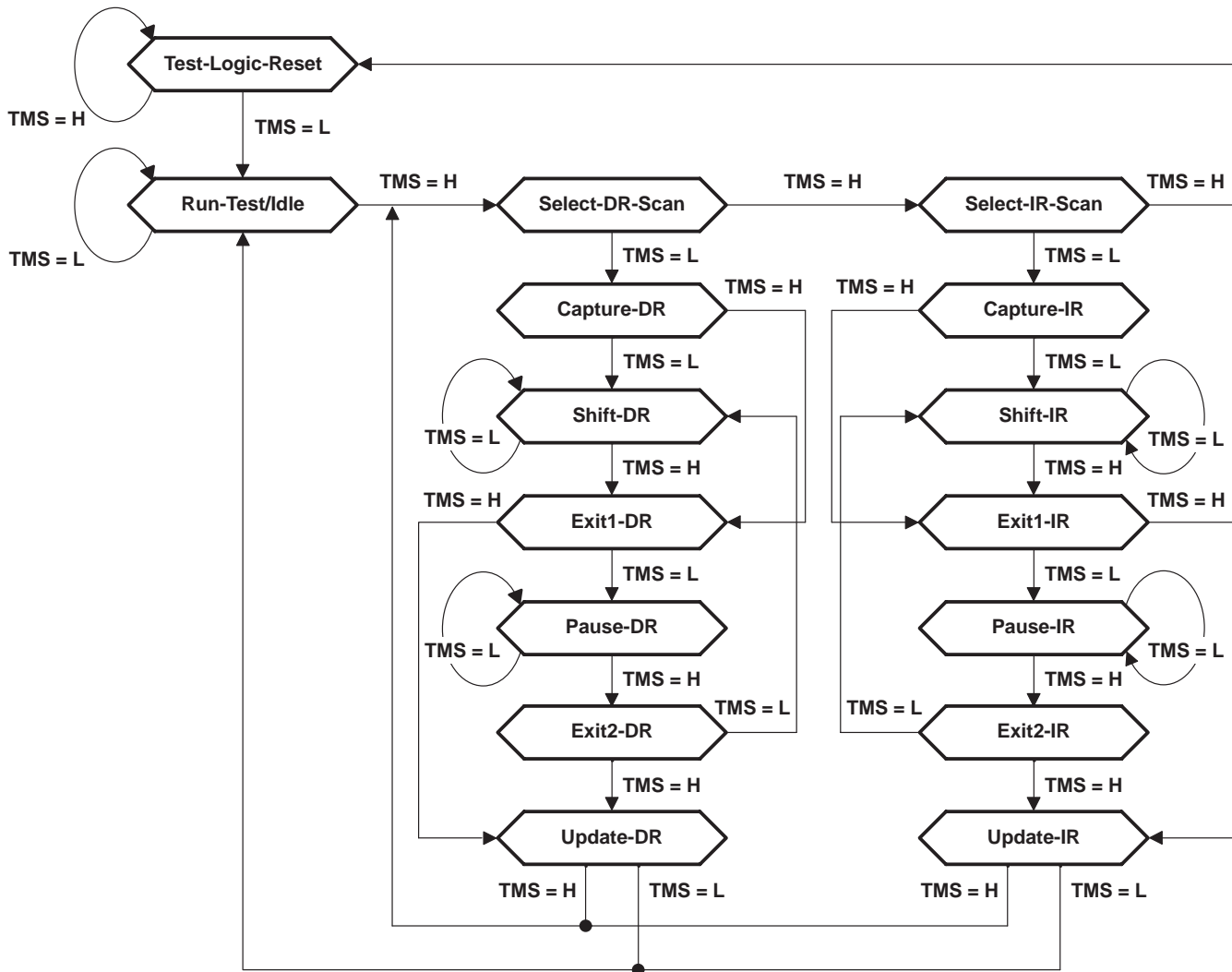

Figure 1. TAP-Controller State Diagram

## state diagram description

The TAP controller is a synchronous finite state machine that provides test control signals throughout the device. The state diagram shown in Figure 1 is in accordance with IEEE Standard 1149.1-1990. The TAP controller proceeds through its states based on the level of TMS at the rising edge of TCK.

As shown, the TAP controller consists of 16 states. There are six stable states (indicated by a looping arrow in the state diagram) and ten unstable states. A stable state is a state the TAP controller can retain for consecutive TCK cycles. Any state that does not meet this criterion is an unstable state.

There are two main paths through the state diagram: one to access and control the selected data register and one to access and control the instruction register. Only one register can be accessed at a time.

## Test-Logic-Reset

The device powers up in the Test-Logic-Reset state. In the stable Test-Logic-Reset state, the test logic is reset and is disabled so that the normal logic function of the device is performed. The instruction register is reset to an opcode that selects the optional IDCODE instruction, if supported, or the BYPASS instruction. Certain data registers also can be reset to their power-up values.

The state machine is constructed such that the TAP controller returns to the Test-Logic-Reset state in no more than five TCK cycles if TMS is left high. TMS has an internal pullup resistor that forces it high if left unconnected or if a board defect causes it to be open circuited.

For the 'ABTH18502A and 'ABTH182502A, the instruction register is reset to the binary value 10000001, which selects the IDCODE instruction. Bits 47–44 in the boundary-scan register are reset to logic 1, ensuring that these cells, which control A-port and B-port outputs, are set to benign values (i.e., if test mode were invoked, the outputs would be at high-impedance state). Reset values of other bits in the boundary-scan register should be considered indeterminate. The boundary-control register is reset to the binary value 010, which selects the PSA test operation.

## Run-Test/Idle

The TAP controller must pass through the Run-Test/Idle state (from Test-Logic-Reset) before executing any test operations. The Run-Test/Idle state also can be entered following data-register or instruction-register scans. Run-Test/Idle is a stable state in which the test logic can be actively running a test or can be idle. The test operations selected by the boundary-control register are performed while the TAP controller is in the Run-Test/Idle state.

## Select-DR-Scan, Select-IR-Scan

No specific function is performed in the Select-DR-Scan and Select-IR-Scan states, and the TAP controller exits either of these states on the next TCK cycle. These states allow the selection of either data-register scan or instruction-register scan.

## Capture-DR

When a data-register scan is selected, the TAP controller must pass through the Capture-DR state. In the Capture-DR state, the selected data register can capture a data value as specified by the current instruction. Such capture operations occur on the rising edge of TCK, upon which the TAP controller exits the Capture-DR state.

## Shift-DR

Upon entry to the Shift-DR state, the data register is placed in the scan path between TDI and TDO, and on the first falling edge of TCK, TDO goes from the high-impedance state to an active state. TDO enables to the logic level present in the least-significant bit of the selected data register.

### **Shift-DR (continued)**

While in the stable Shift-DR state, data is serially shifted through the selected data register on each TCK cycle. The first shift occurs on the first rising edge of TCK after entry to the Shift-DR state (i.e., no shifting occurs during the TCK cycle in which the TAP controller changes from Capture-DR to Shift-DR or from Exit2-DR to Shift-DR). The last shift occurs on the rising edge of TCK, upon which the TAP controller exits the Shift-DR state.

### **Exit1-DR, Exit2-DR**

The Exit1-DR and Exit2-DR states are temporary states that end a data-register scan. It is possible to return to the Shift-DR state from either Exit1-DR or Exit2-DR without recapturing the data register. On the first falling edge of TCK after entry to Exit1-DR, TDO goes from the active state to the high-impedance state.

### **Pause-DR**

No specific function is performed in the stable Pause-DR state, in which the TAP controller can remain indefinitely. The Pause-DR state can suspend and resume data-register scan operations without loss of data.

### **Update-DR**

If the current instruction calls for the selected data register to be updated with current data, such update occurs on the falling edge of TCK, following entry to the Update-DR state.

### **Capture-IR**

When an instruction-register scan is selected, the TAP controller must pass through the Capture-IR state. In the Capture-IR state, the instruction register captures its current status value. This capture operation occurs on the rising edge of TCK, upon which the TAP controller exits the Capture-IR state. For the 'ABTH18502A and 'ABTH182502A, the status value loaded in the Capture-IR state is the fixed binary value 10000001.

### **Shift-IR**

Upon entry to the Shift-IR state, the instruction register is placed in the scan path between TDI and TDO, and on the first falling edge of TCK, TDO goes from the high-impedance state to an active state. TDO enables to the logic level present in the least-significant bit of the instruction register.

While in the stable Shift-IR state, instruction data is serially shifted through the instruction register on each TCK cycle. The first shift occurs on the first rising edge of TCK after entry to the Shift-IR state (i.e., no shifting occurs during the TCK cycle in which the TAP controller changes from Capture-IR to Shift-IR or from Exit2-IR to Shift-IR). The last shift occurs on the rising edge of TCK, upon which the TAP controller exits the Shift-IR state.

### **Exit1-IR, Exit2-IR**

The Exit1-IR and Exit2-IR states are temporary states that end an instruction-register scan. It is possible to return to the Shift-IR state from either Exit1-IR or Exit2-IR without recapturing the instruction register. On the first falling edge of TCK after entry to Exit1-IR, TDO goes from the active state to the high-impedance state.

### **Pause-IR**

No specific function is performed in the stable Pause-IR state, in which the TAP controller can remain indefinitely. The Pause-IR state can suspend and resume instruction-register scan operations without loss of data.

### **Update-IR**

The current instruction is updated and takes effect on the falling edge of TCK, following entry to the Update-IR state.

## register overview

With the exception of the bypass and device-identification registers, any test register can be thought of as a serial-shift register with a shadow latch on each bit. The bypass and device-identification registers differ in that they contain only a shift register. During the appropriate capture state (Capture-IR for instruction register, Capture-DR for data registers), the shift register can be parallel loaded from a source specified by the current instruction. During the appropriate shift state (Shift-IR or Shift-DR), the contents of the shift register are shifted out from TDO while new contents are shifted in at TDI. During the appropriate update state (Update-IR or Update-DR), the shadow latches are updated from the shift register.

## instruction register description

The instruction register (IR) is eight bits long and tells the device what instruction is to be executed. Information contained in the instruction includes the mode of operation (either normal mode, in which the device performs its normal logic function, or test mode, in which the normal logic function is inhibited or altered), the test operation to be performed, which of the four data registers is to be selected for inclusion in the scan path during data-register scans, and the source of data to be captured into the selected data register during Capture-DR.

Table 3 lists the instructions supported by the 'ABTH18502A and 'ABTH182502A. The even-parity feature specified for SCOPE devices is supported in this device. Bit 7 of the instruction opcode is the parity bit. Any instructions that are defined for SCOPE devices but are not supported by this device default to BYPASS.

During Capture-IR, the IR captures the binary value 10000001. As an instruction is shifted in, this value is shifted out via TDO and can be inspected as verification that the IR is in the scan path. During Update-IR, the value that has been shifted into the IR is loaded into shadow latches. At this time, the current instruction is updated and any specified mode change takes effect. At power up or in the Test-Logic-Reset state, the IR is reset to the binary value 10000001, which selects the IDCODE instruction. The IR order of scan is shown in Figure 2.

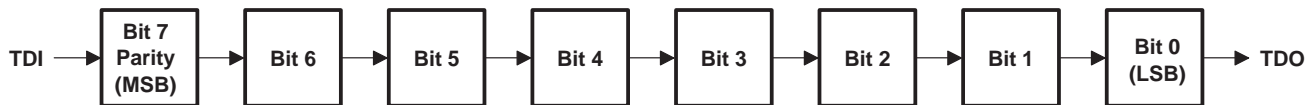

Figure 2. Instruction Register Order of Scan

**SN54ABTH18502A, SN54ABTH182502A, SN74ABTH18502A, SN74ABTH182502A**  
**SCAN TEST DEVICES**  
**WITH 18-BIT UNIVERSAL BUS TRANSCEIVERS**

SCBS164E – AUGUST 1993 – REVISED DECEMBER 1996

**data register description**

**boundary-scan register**

The boundary-scan register (BSR) is 48 bits long. It contains one boundary-scan cell (BSC) for each normal-function input pin and one BSC for each normal-function I/O pin (one single cell for both input data and output data). The BSR is used to store test data that is to be applied externally to the device output pins, and/or to capture data that appears internally at the outputs of the normal on-chip logic and/or externally at the device input pins.

The source of data to be captured into the BSR during Capture-DR is determined by the current instruction. The contents of the BSR can change during Run-Test/Idle as determined by the current instruction. At power up or in Test-Logic-Reset, BSCs 47–44 are reset to logic 1, ensuring that these cells, which control A-port and B-port outputs, are set to benign values (i.e., if test mode were invoked, the outputs would be at high-impedance state). Reset values of other BSCs should be considered indeterminate.

The BSR order of scan is from TDI through bits 47–0 to TDO. Table 1 shows the BSR bits and their associated device pin signals.

**Table 1. Boundary-Scan Register Configuration**

BSR BIT NUMBER	DEVICE SIGNAL	BSR BIT NUMBER	DEVICE SIGNAL	BSR BIT NUMBER	DEVICE SIGNAL
47	2OEAB	35	2A9-I/O	17	2B9-I/O
46	1OEAB	34	2A8-I/O	16	2B8-I/O
45	2OEBA	33	2A7-I/O	15	2B7-I/O
44	1OEBA	32	2A6-I/O	14	2B6-I/O
43	2CLKAB	31	2A5-I/O	13	2B5-I/O
42	1CLKAB	30	2A4-I/O	12	2B4-I/O
41	2CLKBA	29	2A3-I/O	11	2B3-I/O
40	1CLKBA	28	2A2-I/O	10	2B2-I/O
39	2LEAB	27	2A1-I/O	9	2B1-I/O
38	1LEAB	26	1A9-I/O	8	1B9-I/O
37	2LEBA	25	1A8-I/O	7	1B8-I/O
36	1LEBA	24	1A7-I/O	6	1B7-I/O
—	—	23	1A6-I/O	5	1B6-I/O
—	—	22	1A5-I/O	4	1B5-I/O
—	—	21	1A4-I/O	3	1B4-I/O
—	—	20	1A3-I/O	2	1B3-I/O
—	—	19	1A2-I/O	1	1B2-I/O
—	—	18	1A1-I/O	0	1B1-I/O



**boundary-control register**

The boundary-control register (BCR) is three bits long. The BCR is used in the context of the boundary-run test (RUNT) instruction to implement additional test operations not included in the basic SCOPE instruction set. Such operations include PRPG, PSA, and binary count up (COUNT). Table 4 shows the test operations that are decoded by the BCR.

During Capture-DR, the contents of the BCR are not changed. At power up or in Test-Logic-Reset, the BCR is reset to the binary value 010, which selects the PSA test operation. The BCR order of scan is shown in Figure 3.

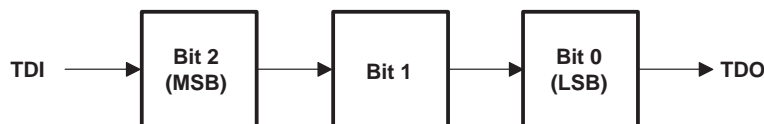

**Figure 3. Boundary-Control Register Order of Scan**

**bypass register**

The bypass register is a 1-bit scan path that can be selected to shorten the length of the system scan path, reducing the number of bits per test pattern that must be applied to complete a test operation. During Capture-DR, the bypass register captures a logic 0. The bypass register order of scan is shown in Figure 4.

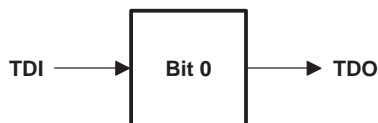

**Figure 4. Bypass Register Order of Scan**

# SN54ABTH18502A, SN54ABTH182502A, SN74ABTH18502A, SN74ABTH182502A SCAN TEST DEVICES WITH 18-BIT UNIVERSAL BUS TRANSCEIVERS

SCBS164E – AUGUST 1993 – REVISED DECEMBER 1996

## device-identification register

The device-identification register (IDR) is 32 bits long. It can be selected and read to identify the manufacturer, part number, and version of this device.

For the 'ABTH18502A , the binary value 0000000000000100111000000101111 (0002702F, hex) is captured (during Capture-DR state) in the IDR to identify this device as Texas Instruments SN54/74ABTH18502A.

For the 'ABTH182502A , the binary value 0000000000000101011000000101111 (0002B02F, hex) is captured (during Capture-DR state) in the IDR to identify this device as Texas Instruments SN54/74ABTH182502A.

The IDR order of scan is from TDI through bits 31–0 to TDO. Table 2 shows the IDR bits and their significance.

**Table 2. Device-Identification Register Configuration**

IDR BIT NUMBER	IDENTIFICATION SIGNIFICANCE	IDR BIT NUMBER	IDENTIFICATION SIGNIFICANCE	IDR BIT NUMBER	IDENTIFICATION SIGNIFICANCE
31	VERSION3	27	PARTNUMBER15	11	MANUFACTURER10†
30	VERSION2	26	PARTNUMBER14	10	MANUFACTURER09†
29	VERSION1	25	PARTNUMBER13	9	MANUFACTURER08†
28	VERSION0	24	PARTNUMBER12	8	MANUFACTURER07†
—	—	23	PARTNUMBER11	7	MANUFACTURER06†
—	—	22	PARTNUMBER10	6	MANUFACTURER05†
—	—	21	PARTNUMBER09	5	MANUFACTURER04†
—	—	20	PARTNUMBER08	4	MANUFACTURER03†
—	—	19	PARTNUMBER07	3	MANUFACTURER02†
—	—	18	PARTNUMBER06	2	MANUFACTURER01†
—	—	17	PARTNUMBER05	1	MANUFACTURER00†
—	—	16	PARTNUMBER04	0	LOGIC1†
—	—	15	PARTNUMBER03	—	—
—	—	14	PARTNUMBER02	—	—
—	—	13	PARTNUMBER01	—	—
—	—	12	PARTNUMBER00	—	—

† Note that for TI products, bits 11–0 of the device-identification register always contain the binary value 000000101111 (02F, hex).



## instruction-register opcode description

The instruction-register opcodes are shown in Table 3. The following descriptions detail the operation of each instruction.

**Table 3. Instruction-Register Opcodes**

BINARY CODE† BIT 7 → BIT 0 MSB → LSB	SCOPE OPCODE	DESCRIPTION	SELECTED DATA REGISTER	MODE
00000000	EXTEST	Boundary scan	Boundary scan	Test
10000001	IDCODE	Identification read	Device identification	Normal
10000010	SAMPLE/PRELOAD	Sample boundary	Boundary scan	Normal
00000011	BYPASS‡	Bypass scan	Bypass	Normal
10000100	BYPASS‡	Bypass scan	Bypass	Normal
00000101	BYPASS‡	Bypass scan	Bypass	Normal
00000110	HIGHZ	Control boundary to high impedance	Bypass	Modified test
10000111	CLAMP	Control boundary to 1/0	Bypass	Test
10001000	BYPASS‡	Bypass scan	Bypass	Normal
00001001	RUNT	Boundary-run test	Bypass	Test
00001010	READBN	Boundary read	Boundary scan	Normal
10001011	READBT	Boundary read	Boundary scan	Test
00001100	CELLTST	Boundary self test	Boundary scan	Normal
10001101	TOPHIP	Boundary toggle outputs	Bypass	Test
10001110	SCANCN	Boundary-control register scan	Boundary control	Normal
00001111	SCANCT	Boundary-control register scan	Boundary control	Test
All others	BYPASS	Bypass scan	Bypass	Normal

† Bit 7 is used to maintain even parity in the 8-bit instruction.

‡ The BYPASS instruction is executed in lieu of a SCOPE instruction that is not supported in the 'ABTH18502A or 'ABTH182502A.

### boundary scan

This instruction conforms to the IEEE Standard 1149.1-1990 EXTEST instruction. The BSR is selected in the scan path. Data appearing at the device input and I/O pins is captured in the associated BSCs. Data that has been scanned into the I/O BSCs for pins in the output mode is applied to the device I/O pins. Data present at the device pins, except for output-enables, is passed through the BSCs to the normal on-chip logic. For I/O pins, the operation of a pin as input or output is determined by the contents of the output-enable BSCs (bits 47–44 of the BSR). When a given output enable is active (logic 0), the associated I/O pins operate in the output mode. Otherwise, the I/O pins operate in the input mode. The device operates in the test mode.

### identification read

This instruction conforms to the IEEE Standard 1149.1-1990 IDCODE instruction. The IDR is selected in the scan path. The device operates in the normal mode.

### sample boundary

This instruction conforms to the IEEE Standard 1149.1-1990 SAMPLE/PRELOAD instruction. The BSR is selected in the scan path. Data appearing at the device input pins and I/O pins in the input mode is captured in the associated BSCs, while data appearing at the outputs of the normal on-chip logic is captured in the BSCs associated with I/O pins in the output mode. The device operates in the normal mode.

# SN54ABTH18502A, SN54ABTH182502A, SN74ABTH18502A, SN74ABTH182502A

## SCAN TEST DEVICES

### WITH 18-BIT UNIVERSAL BUS TRANSCEIVERS

SCBS164E – AUGUST 1993 – REVISED DECEMBER 1996

---

#### **bypass scan**

This instruction conforms to the IEEE Standard 1149.1-1990 BYPASS instruction. The bypass register is selected in the scan path. A logic 0 value is captured in the bypass register during Capture-DR. The device operates in the normal mode.

#### **control boundary to high impedance**

This instruction conforms to the IEEE Standard 1149.1a-1993 HIGHZ instruction. The bypass register is selected in the scan path. A logic 0 value is captured in the bypass register during Capture-DR. The device operates in a modified test mode in which all device I/O pins are placed in the high-impedance state, the device input pins remain operational, and the normal on-chip logic function is performed.

#### **control boundary to 1/0**

This instruction conforms to the IEEE Standard 1149.1a-1993 CLAMP instruction. The bypass register is selected in the scan path. A logic 0 value is captured in the bypass register during Capture-DR. Data in the I/O BSCs for pins in the output mode is applied to the device I/O pins. The device operates in the test mode.

#### **boundary-run test**

The bypass register is selected in the scan path. A logic 0 value is captured in the bypass register during Capture-DR. The device operates in the test mode. The test operation specified in the BCR is executed during Run-Test/Idle. The five test operations decoded by the BCR are: sample inputs/toggle outputs (TOPSIP), PRPG, PSA, simultaneous PSA and PRPG (PSA/PRPG), and simultaneous PSA and binary count up (PSA/COUNT).

#### **boundary read**

The BSR is selected in the scan path. The value in the BSR remains unchanged during Capture-DR. This instruction is useful for inspecting data after a PSA operation.

#### **boundary self test**

The BSR is selected in the scan path. All BSCs capture the inverse of their current values during Capture-DR. In this way, the contents of the shadow latches can be read out to verify the integrity of both shift-register and shadow-latch elements of the BSR. The device operates in the normal mode.

#### **boundary toggle outputs**

The bypass register is selected in the scan path. A logic 0 value is captured in the bypass register during Capture-DR. Data in the shift-register elements of the selected output-mode BSCs is toggled on each rising edge of TCK in Run-Test/Idle, updated in the shadow latches, and applied to the associated device I/O pins on each falling edge of TCK in Run-Test/Idle. Data in the input-mode BSCs remains constant. Data appearing at the device input or I/O pins is not captured in the input-mode BSCs. The device operates in the test mode.

#### **boundary-control-register scan**

The BCR is selected in the scan path. The value in the BCR remains unchanged during Capture-DR. This operation must be performed before a RUNT operation to specify which test operation is to be executed.



**boundary-control-register opcode description**

The BCR opcodes are decoded from BCR bits 2–0 as shown in Table 4. The selected test operation is performed while the RUNT instruction is executed in the Run-Test/Idle state. The following descriptions detail the operation of each BCR instruction and illustrate the associated PSA and PRPG algorithms.

**Table 4. Boundary-Control Register Opcodes**

BINARY CODE BIT 2 → BIT 0 MSB → LSB	DESCRIPTION
X00	Sample inputs/toggle outputs (TOPSIP)
X01	Pseudo-random pattern generation/36-bit mode (PRPG)
X10	Parallel-signature analysis/36-bit mode (PSA)
011	Simultaneous PSA and PRPG/18-bit mode (PSA/PRPG)
111	Simultaneous PSA and binary count up/18-bit mode (PSA/COUNT)

While the control input BSCs (bits 47–36) are not included in the toggle, PSA, PRPG, or COUNT algorithms, the output-enable BSCs (bits 47–44 of the BSR) control the drive state (active or high impedance) of the selected device output pins. These BCR instructions are valid only when both bytes of the device are operating in one direction of data flow (that is,  $1\overline{OEAB} \neq 1\overline{OEBA}$  and  $2\overline{OEAB} \neq 2\overline{OEBA}$ ) and in the same direction of data flow (that is,  $1\overline{OEAB} = 2\overline{OEAB}$  and  $1\overline{OEBA} = 2\overline{OEBA}$ ). Otherwise, the bypass instruction is operated.

**sample inputs/toggle outputs (TOPSIP)**

Data appearing at the selected device input-mode I/O pins is captured in the shift-register elements of the associated BSCs on each rising edge of TCK. Data in the shift-register elements of the selected output-mode BSCs is toggled on each rising edge of TCK, updated in the shadow latches, and applied to the associated device I/O pins on each falling edge of TCK.

**SN54ABTH18502A, SN54ABTH182502A, SN74ABTH18502A, SN74ABTH182502A**  
**SCAN TEST DEVICES**  
**WITH 18-BIT UNIVERSAL BUS TRANSCEIVERS**  
 SCBS164E – AUGUST 1993 – REVISED DECEMBER 1996

**pseudo-random pattern generation (PRPG)**

A pseudo-random pattern is generated in the shift-register elements of the selected BSCs on each rising edge of TCK, updated in the shadow latches, and applied to the associated device output-mode I/O pins on each falling edge of TCK. Figures 5 and 6 illustrate the 36-bit linear-feedback shift-register algorithms through which the patterns are generated. An initial seed value should be scanned into the BSR before performing this operation. A seed value of all zeroes does not produce additional patterns.

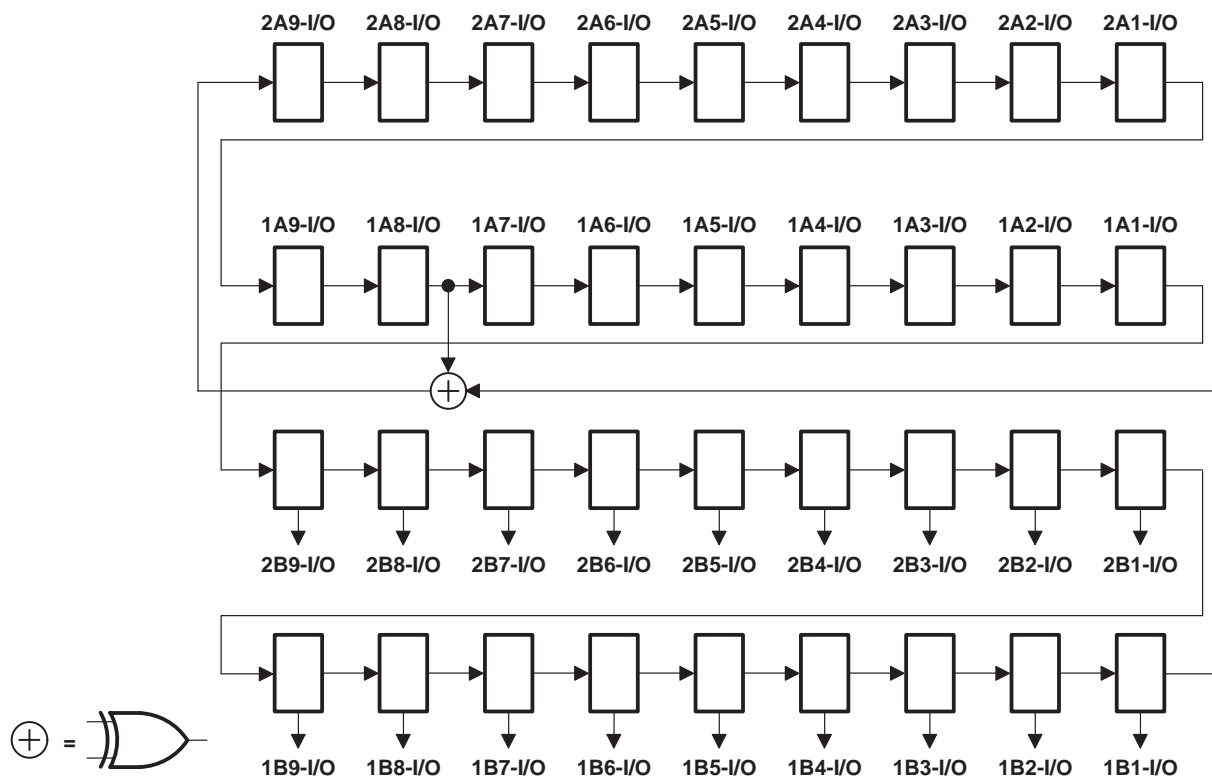

**Figure 5. 36-Bit PRPG Configuration ( $1\overline{OEAB} = 2\overline{OEAB} = 0$ ,  $1\overline{OEBA} = 2\overline{OEBA} = 1$ )**

pseudo-random pattern generation (PRPG) (continued)

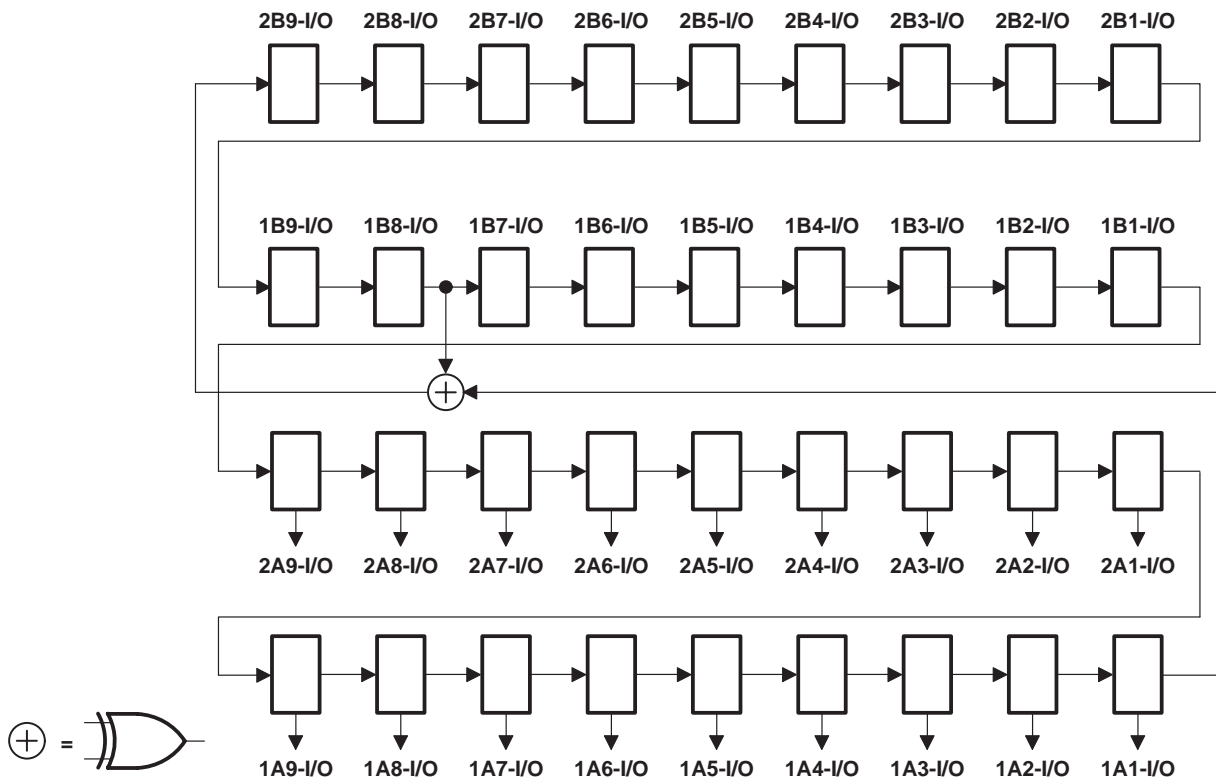
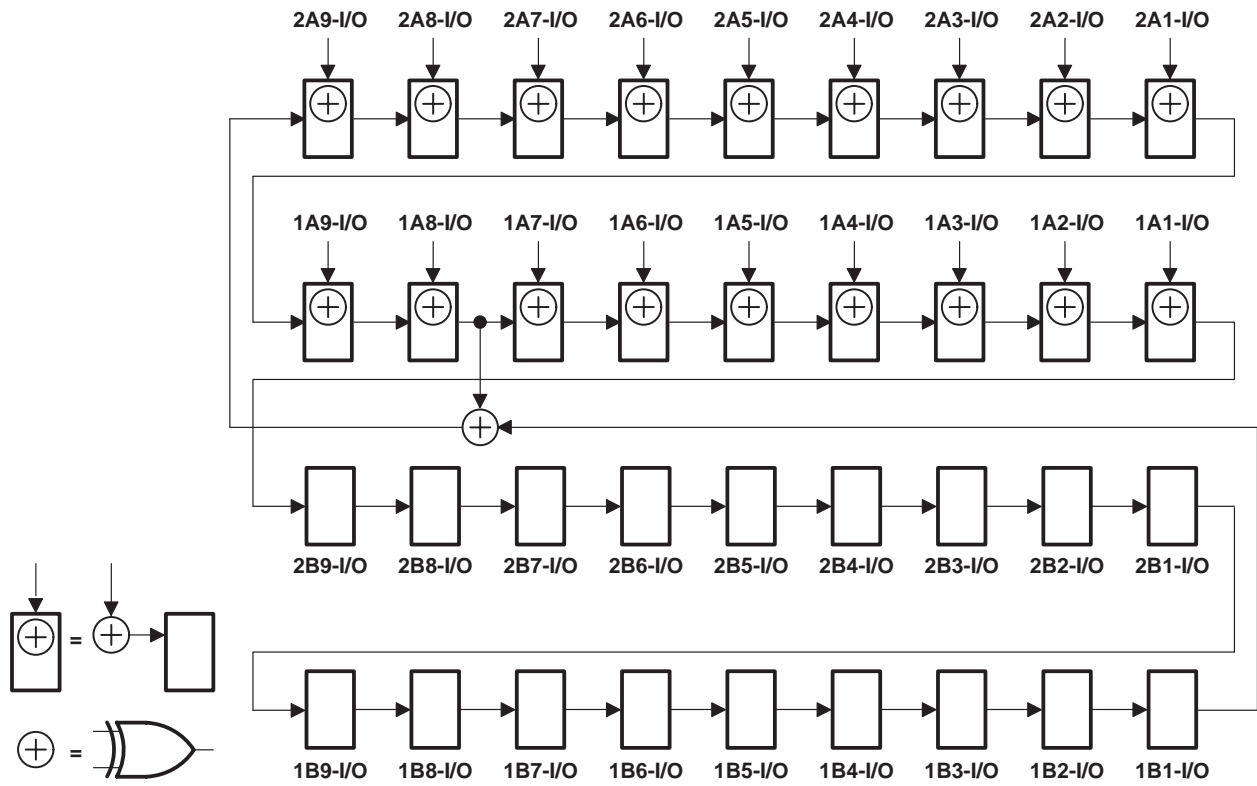

Figure 6. 36-Bit PRPG Configuration ( $1\overline{OEAB} = 2\overline{OEAB} = 1$ ,  $1\overline{OEBA} = 2\overline{OEBA} = 0$ )

**SN54ABTH18502A, SN54ABTH182502A, SN74ABTH18502A, SN74ABTH182502A**  
**SCAN TEST DEVICES**  
**WITH 18-BIT UNIVERSAL BUS TRANSCEIVERS**  
 SCBS164E – AUGUST 1993 – REVISED DECEMBER 1996

**parallel-signature analysis (PSA)**

Data appearing at the selected device input-mode I/O pins is compressed into a 36-bit parallel signature in the shift-register elements of the selected BSCs on each rising edge of TCK. Data in the shadow latches of the selected output-mode BSCs remains constant and is applied to the associated device I/O pins. Figures 7 and 8 illustrate the 36-bit linear-feedback shift-register algorithms through which the signature is generated. An initial seed value should be scanned into the BSR before performing this operation.



**Figure 7. 36-Bit PSA Configuration ( $\overline{1OEAB} = \overline{2OEAB} = 0, \overline{1OEBA} = \overline{2OEBA} = 1$ )**

parallel-signature analysis (PSA) (continued)

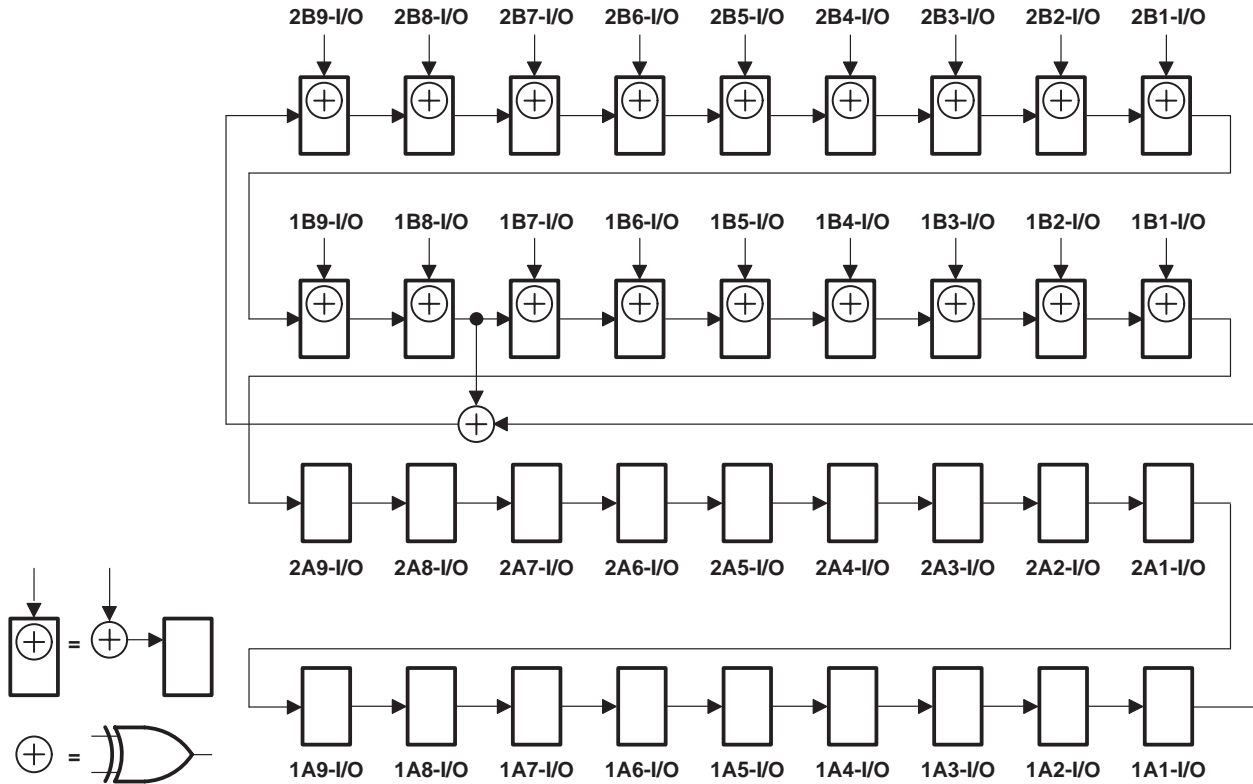

Figure 8. 36-Bit PSA Configuration ( $1\overline{OEAB} = 2\overline{OEAB} = 1$ ,  $1\overline{OEBA} = 2\overline{OEBA} = 0$ )

# SN54ABTH18502A, SN54ABTH182502A, SN74ABTH18502A, SN74ABTH182502A SCAN TEST DEVICES

## WITH 18-BIT UNIVERSAL BUS TRANSCEIVERS

SCBS164E – AUGUST 1993 – REVISED DECEMBER 1996

### simultaneous PSA and PRPG (PSA/PRPG)

Data appearing at the selected device input-mode I/O pins is compressed into an 18-bit parallel signature in the shift-register elements of the selected input-mode BSCs on each rising edge of TCK. At the same time, an 18-bit pseudo-random pattern is generated in the shift-register elements of the selected output-mode BSCs on each rising edge of TCK, updated in the shadow latches, and applied to the associated device I/O pins on each falling edge of TCK. Figures 9 and 10 illustrate the 18-bit linear-feedback shift-register algorithms through which the signature and patterns are generated. An initial seed value should be scanned into the BSR before performing this operation. A seed value of all zeroes does not produce additional patterns.

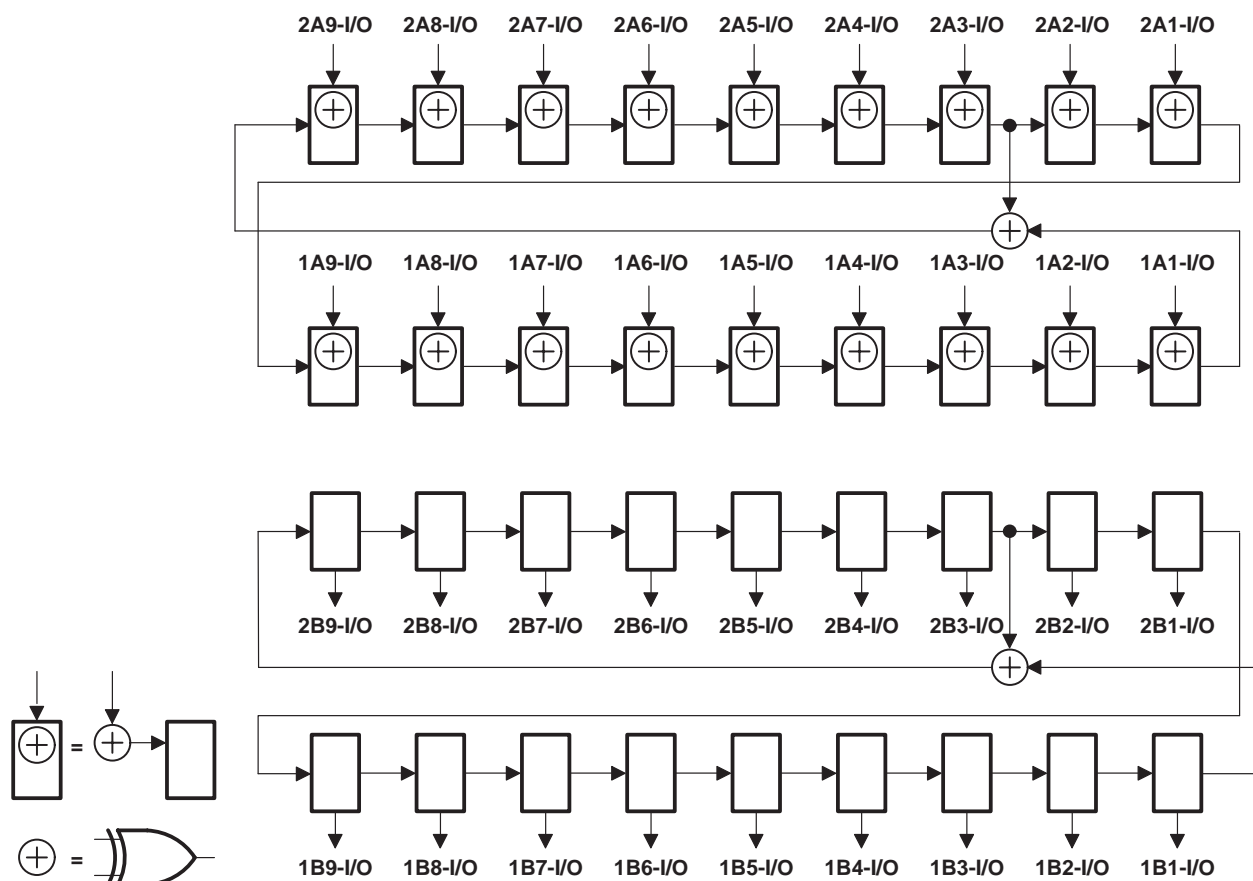

Figure 9. 18-Bit PSA/PRPG Configuration ( $\overline{1OEAB} = \overline{2OEAB} = 0$ ,  $\overline{1OEBA} = \overline{2OEBA} = 1$ )

simultaneous PSA and PRPG (PSA/PRPG) (continued)

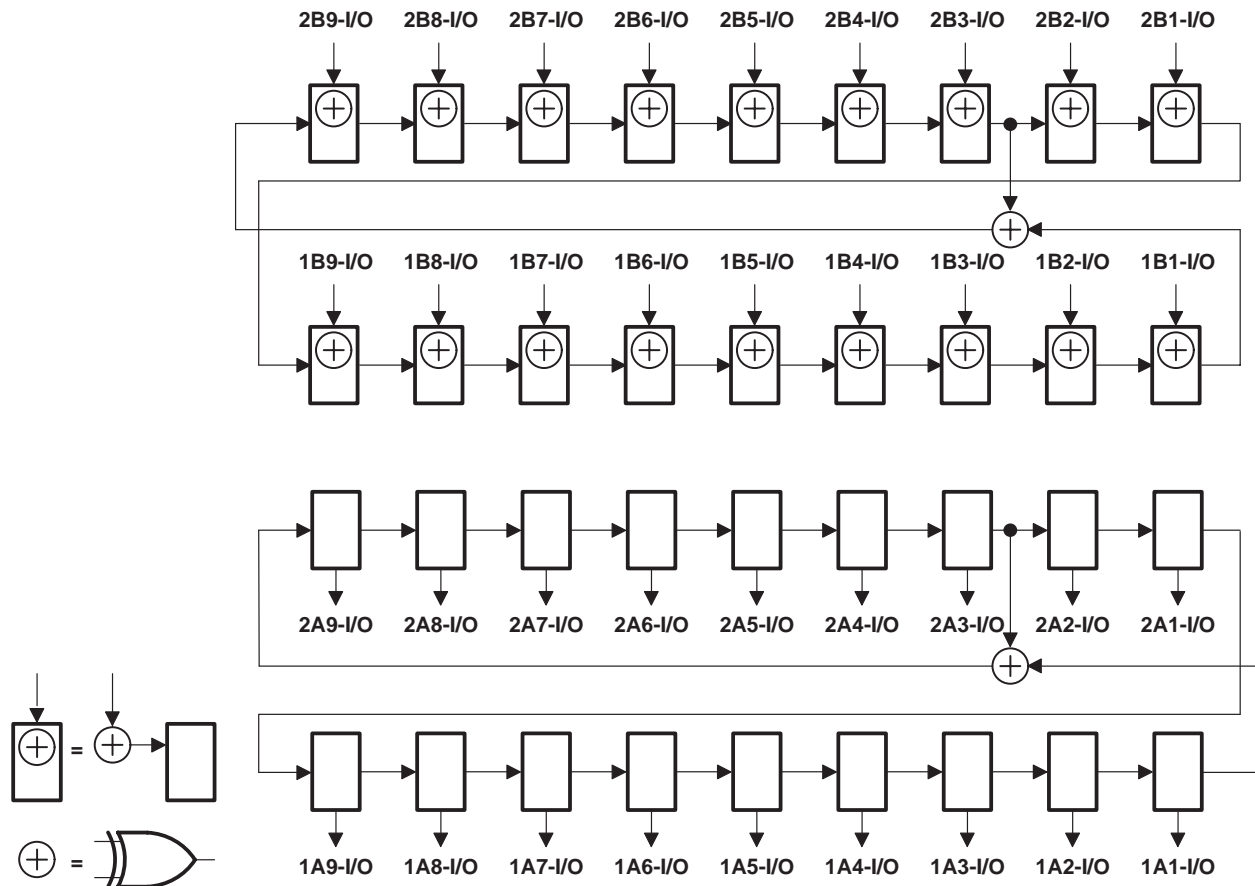

Figure 10. 18-Bit PSA/PRPG Configuration ( $1\overline{OEAB} = 2\overline{OEAB} = 1$ ,  $1\overline{OEBA} = 2\overline{OEBA} = 0$ )

**SN54ABTH18502A, SN54ABTH182502A, SN74ABTH18502A, SN74ABTH182502A**  
**SCAN TEST DEVICES**  
**WITH 18-BIT UNIVERSAL BUS TRANSCEIVERS**  
 SCBS164E – AUGUST 1993 – REVISED DECEMBER 1996

**simultaneous PSA and binary count up (PSA/COUNT)**

Data appearing at the selected device input-mode I/O pins is compressed into an 18-bit parallel signature in the shift-register elements of the selected input-mode BSCs on each rising edge of TCK. At the same time, an 18-bit binary count-up pattern is generated in the shift-register elements of the selected output-mode BSCs on each rising edge of TCK, updated in the shadow latches, and applied to the associated device I/O pins on each falling edge of TCK. Figures 11 and 12 illustrate the 18-bit linear-feedback shift-register algorithms through which the signature is generated. An initial seed value should be scanned into the BSR before performing this operation.

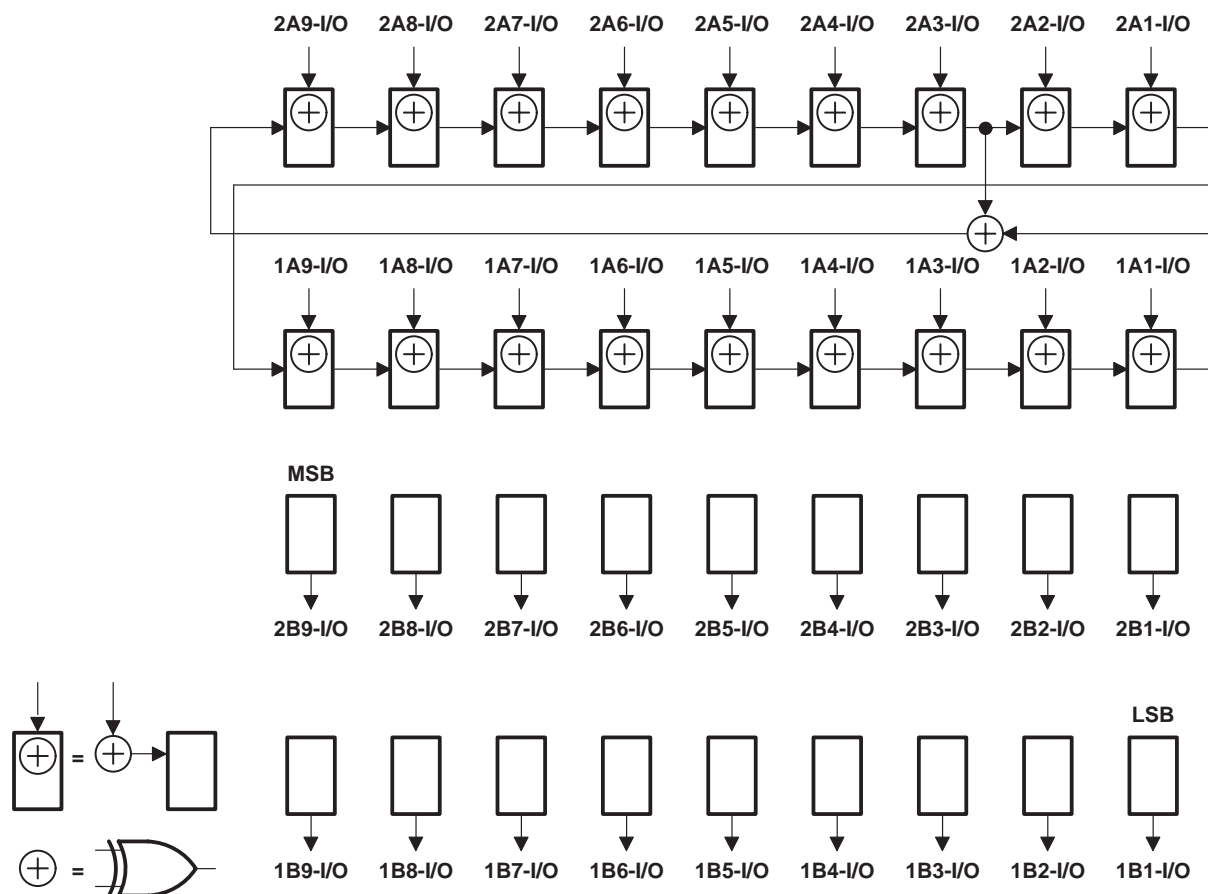

Figure 11. 18-Bit PSA/COUNT Configuration ( $\overline{1OEAB} = \overline{2OEAB} = 0$ ,  $\overline{1OEBA} = \overline{2OEBA} = 1$ )



# SN54ABTH18502A, SN54ABTH182502A, SN74ABTH18502A, SN74ABTH182502A SCAN TEST DEVICES

## WITH 18-BIT UNIVERSAL BUS TRANSCEIVERS

SCBS164E – AUGUST 1993 – REVISED DECEMBER 1996

### timing description

All test operations of the 'ABTH18502A and 'ABTH182502A are synchronous to TCK. Data on the TDI, TMS, and normal-function inputs is captured on the rising edge of TCK. Data appears on the TDO and normal-function output pins on the falling edge of TCK. The TAP controller is advanced through its states (as shown in Figure 1) by changing the value of TMS on the falling edge of TCK and then applying a rising edge to TCK.

A simple timing example is shown in Figure 13. In this example, the TAP controller begins in the Test-Logic-Reset state and is advanced through its states, to perform one instruction-register scan and one data-register scan. While in the Shift-IR and Shift-DR states, TDI is used to input serial data, and TDO is used to output serial data. The TAP controller is then returned to the Test-Logic-Reset state. Table 5 details the operation of the test circuitry during each TCK cycle.

**Table 5. Explanation of Timing Example**

TCK CYCLE(S)	TAP STATE AFTER TCK	DESCRIPTION
1	Test-Logic-Reset	TMS is changed to a logic 0 value on the falling edge of TCK to begin advancing the TAP controller toward the desired state.
2	Run-Test/Idle	
3	Select-DR-Scan	
4	Select-IR-Scan	
5	Capture-IR	The IR captures the 8-bit binary value 10000001 on the rising edge of TCK as the TAP controller exits the Capture-IR state.
6	Shift-IR	TDO becomes active and TDI is made valid on the falling edge of TCK. The first bit is shifted into the TAP on the rising edge of TCK as the TAP controller advances to the next state.
7–13	Shift-IR	One bit is shifted into the IR on each TCK rising edge. With TDI held at a logic 1 value, the 8-bit binary value 11111111 is serially scanned into the IR. At the same time, the 8-bit binary value 10000001 is serially scanned out of the IR via TDO. In TCK cycle 13, TMS is changed to a logic 1 value to end the IR scan on the next TCK cycle. The last bit of the instruction is shifted as the TAP controller advances from Shift-IR to Exit1-IR.
14	Exit1-IR	TDO becomes inactive (goes to the high-impedance state) on the falling edge of TCK.
15	Update-IR	The IR is updated with the new instruction (BYPASS) on the falling edge of TCK.
16	Select-DR-Scan	
17	Capture-DR	The bypass register captures a logic 0 value on the rising edge of TCK as the TAP controller exits the Capture-DR state.
18	Shift-DR	TDO becomes active and TDI is made valid on the falling edge of TCK. The first bit is shifted into the TAP on the rising edge of TCK as the TAP controller advances to the next state.
19–20	Shift-DR	The binary value 101 is shifted in via TDI, while the binary value 010 is shifted out via TDO.
21	Exit1-DR	TDO becomes inactive (goes to the high-impedance state) on the falling edge of TCK.
22	Update-DR	In general, the selected data register is updated with the new data on the falling edge of TCK.
23	Select-DR-Scan	
24	Select-IR-Scan	
25	Test-Logic-Reset	Test operation completed



**SN54ABTH18502A, SN54ABTH182502A, SN74ABTH18502A, SN74ABTH182502A**  
**SCAN TEST DEVICES**  
**WITH 18-BIT UNIVERSAL BUS TRANSCEIVERS**  
 SCBS164E – AUGUST 1993 – REVISED DECEMBER 1996

**recommended operating conditions**

	SN54ABTH18502A		SN74ABTH18502A		UNIT
	MIN	MAX	MIN	MAX	
V <sub>CC</sub> Supply voltage	4.5	5.5	4.5	5.5	V
V <sub>IH</sub> High-level input voltage	2		2		V
V <sub>IL</sub> Low-level input voltage		0.8		0.8	V
V <sub>I</sub> Input voltage	0	V <sub>CC</sub>	0	V <sub>CC</sub>	V
I <sub>OH</sub> High-level output current		-24		-32	mA
I <sub>OL</sub> Low-level output current		48		64	mA
Δt/Δv Input transition rise or fall rate		10		10	ns/V
T <sub>A</sub> Operating free-air temperature	-55	125	-40	85	°C



electrical characteristics over recommended operating free-air temperature range (unless otherwise noted)

PARAMETER		TEST CONDITIONS		SN54ABTH18502A					UNIT	
				T <sub>A</sub> = 25°C			T <sub>A</sub> = -55°C to 125°C			
				MIN	TYP†	MAX	MIN	MAX		
V <sub>IK</sub>		V <sub>CC</sub> = 4.5 V, I <sub>I</sub> = -18 mA		-1.2			-1.2		V	
V <sub>OH</sub>		V <sub>CC</sub> = 4.5 V, I <sub>OH</sub> = -3 mA		2.5			2.5		V	
		V <sub>CC</sub> = 5 V, I <sub>OH</sub> = -3 mA		3			3			
		V <sub>CC</sub> = 4.5 V, I <sub>OH</sub> = -24 mA		2			2			
V <sub>OL</sub>		V <sub>CC</sub> = 4.5 V, I <sub>OL</sub> = 48 mA		0.55			0.55		V	
I <sub>I</sub>	CLK, LE, TCK V <sub>CC</sub> = 0 to 5.5 V, A or B ports	V <sub>CC</sub> = 0 to 5.5 V, V <sub>I</sub> = V <sub>CC</sub> or GND		±1			±1		μA	
	V <sub>CC</sub> = 5.5 V, V <sub>I</sub> = V <sub>CC</sub> or GND		±20			±20				
I <sub>IH</sub>	OE, TDI, TMS	V <sub>CC</sub> = 5.5 V, V <sub>I</sub> = V <sub>CC</sub>		10			10		μA	
I <sub>IL</sub>	OE, TDI, TMS	V <sub>CC</sub> = 5.5 V, V <sub>I</sub> = GND		-40 -150			-40 -150		μA	
I <sub>I(hold)</sub> ‡	A or B ports	V <sub>CC</sub> = 4.5 V		V <sub>I</sub> = 0.8 V		75 220 500		75 500		μA
				V <sub>I</sub> = 2 V		-75 -180 -500		-75 -500		
I <sub>OZH</sub>	TDO	V <sub>CC</sub> = 2.1 V to 5.5 V, V <sub>O</sub> = 2.7 V, $\overline{OE}$ = 2 V		10			10		μA	
I <sub>OZL</sub>	TDO	V <sub>CC</sub> = 2.1 V to 5.5 V, V <sub>O</sub> = 0.5 V, $\overline{OE}$ = 2 V		-10			-10		μA	
I <sub>OZPU</sub>	TDO	V <sub>CC</sub> = 0 to 2.1 V, V <sub>O</sub> = 2.7 V or 0.5 V, $\overline{OE}$ = 0.8 V		±50			±50		μA	
I <sub>OZPD</sub>	TDO	V <sub>CC</sub> = 2.1 V to 0, V <sub>O</sub> = 2.7 V or 0.5 V, $\overline{OE}$ = 0.8 V		±50			±50		μA	
I <sub>off</sub>		V <sub>CC</sub> = 0, V <sub>I</sub> or V <sub>O</sub> ≤ 4.5 V		±100					μA	
I <sub>CEX</sub>	Outputs high	V <sub>CC</sub> = 5.5 V, V <sub>O</sub> = 5.5 V		50			50		μA	
I <sub>O</sub> §		V <sub>CC</sub> = 5.5 V, V <sub>O</sub> = 2.5 V		-50 -110 -200			-50 -200		mA	
I <sub>CC</sub>	Outputs high	V <sub>CC</sub> = 5.5 V, I <sub>O</sub> = 0, V <sub>I</sub> = V <sub>CC</sub> or GND		A or B ports		1.6 5.5		5.5		mA
	Outputs low					19 24		24		
	Outputs disabled					0.9 3.6		3.6		
ΔI <sub>CC</sub> ¶		V <sub>CC</sub> = 5.5 V, One input at 3.4 V, Other inputs at V <sub>CC</sub> or GND		1.5			1.5		mA	
C <sub>i</sub>	Control inputs	V <sub>I</sub> = 2.5 V or 0.5 V		7					pF	
C <sub>io</sub>	A or B ports	V <sub>O</sub> = 2.5 V or 0.5 V		10					pF	
C <sub>o</sub>	TDO	V <sub>O</sub> = 2.5 V or 0.5 V		7					pF	

† All typical values are at V<sub>CC</sub> = 5 V.

‡ The parameter I<sub>I(hold)</sub> includes the off-state output leakage current.

§ Not more than one output should be tested at a time, and the duration of the test should not exceed one second.

¶ This is the increase in supply current for each input that is at the specified TTL voltage level rather than V<sub>CC</sub> or GND.

**SN54ABTH18502A, SN54ABTH182502A, SN74ABTH18502A, SN74ABTH182502A**  
**SCAN TEST DEVICES**

**WITH 18-BIT UNIVERSAL BUS TRANSCEIVERS**

SCBS164E – AUGUST 1993 – REVISED DECEMBER 1996

**electrical characteristics over recommended operating free-air temperature range (unless otherwise noted)**

PARAMETER		TEST CONDITIONS		SN74ABTH18502A					UNIT		
				T <sub>A</sub> = 25°C			T <sub>A</sub> = -40°C to 85°C				
				MIN	TYP†	MAX	MIN	MAX			
V <sub>IK</sub>		V <sub>CC</sub> = 4.5 V, I <sub>I</sub> = -18 mA		-1.2			-1.2		V		
V <sub>OH</sub>		V <sub>CC</sub> = 4.5 V, I <sub>OH</sub> = -3 mA		2.5			2.5		V		
		V <sub>CC</sub> = 5 V, I <sub>OH</sub> = -3 mA		3			3				
		V <sub>CC</sub> = 4.5 V		I <sub>OH</sub> = -24 mA		2					
				I <sub>OH</sub> = -32 mA		2					
V <sub>OL</sub>		V <sub>CC</sub> = 4.5 V		I <sub>OL</sub> = 48 mA		0.55			V		
				I <sub>OL</sub> = 64 mA		0.55				0.55	
I <sub>I</sub>	CLK, LE, TCK	V <sub>CC</sub> = 0 to 5.5 V, V <sub>I</sub> = V <sub>CC</sub> or GND		±1			±1		μA		
	A or B ports	V <sub>CC</sub> = 5.5 V, V <sub>I</sub> = V <sub>CC</sub> or GND		±20			±20				
I <sub>IH</sub>	$\overline{OE}$ , TDI, TMS	V <sub>CC</sub> = 5.5 V, V <sub>I</sub> = V <sub>CC</sub>		10			10		μA		
I <sub>IL</sub>	$\overline{OE}$ , TDI, TMS	V <sub>CC</sub> = 5.5 V, V <sub>I</sub> = GND		-40	-150		-40	-150		μA	
I <sub>I(hold)</sub> ‡	A or B ports	V <sub>CC</sub> = 4.5 V		V <sub>I</sub> = 0.8 V		75	220	500	75	500	μA
				V <sub>I</sub> = 2 V		-75	-180	-500	-75	-500	
I <sub>OZH</sub>	TDO	V <sub>CC</sub> = 2.1 V to 5.5 V, V <sub>O</sub> = 2.7 V, $\overline{OE}$ = 2 V		10			10		μA		
I <sub>OZL</sub>	TDO	V <sub>CC</sub> = 2.1 V to 5.5 V, V <sub>O</sub> = 0.5 V, $\overline{OE}$ = 2 V		-10			-10		μA		
I <sub>OZPU</sub>	TDO	V <sub>CC</sub> = 0 to 2.1 V, V <sub>O</sub> = 2.7 V or 0.5 V, $\overline{OE}$ = 0.8 V		±50			±50		μA		
I <sub>OZPD</sub>	TDO	V <sub>CC</sub> = 2.1 V to 0, V <sub>O</sub> = 2.7 V or 0.5 V, $\overline{OE}$ = 0.8 V		±50			±50		μA		
I <sub>off</sub>		V <sub>CC</sub> = 0, V <sub>I</sub> or V <sub>O</sub> ≤ 4.5 V		±100			±100		μA		
I <sub>CEX</sub>	Outputs high	V <sub>CC</sub> = 5.5 V, V <sub>O</sub> = 5.5 V		50			50		μA		
I <sub>O</sub> §		V <sub>CC</sub> = 5.5 V, V <sub>O</sub> = 2.5 V		-50	-110	-200	-50	-200	mA		
I <sub>CC</sub>	Outputs high	V <sub>CC</sub> = 5.5 V, I <sub>O</sub> = 0, V <sub>I</sub> = V <sub>CC</sub> or GND		A or B ports		1.6	2.2		2.2	mA	
	Outputs low					19	24		24		
	Outputs disabled					0.9	2		2		
ΔI <sub>CC</sub> ¶		V <sub>CC</sub> = 5.5 V, One input at 3.4 V, Other inputs at V <sub>CC</sub> or GND		1.5			1.5		mA		
C <sub>i</sub>	Control inputs	V <sub>I</sub> = 2.5 V or 0.5 V		5					pF		
C <sub>io</sub>	A or B ports	V <sub>O</sub> = 2.5 V or 0.5 V		10					pF		
C <sub>o</sub>	TDO	V <sub>O</sub> = 2.5 V or 0.5 V		8					pF		

† All typical values are at V<sub>CC</sub> = 5 V.

‡ The parameter I<sub>I(hold)</sub> includes the off-state output leakage current.

§ Not more than one output should be tested at a time, and the duration of the test should not exceed one second.

¶ This is the increase in supply current for each input that is at the specified TTL voltage level rather than V<sub>CC</sub> or GND.



timing requirements over recommended ranges of supply voltage and operating free-air temperature (unless otherwise noted) (normal mode) (see Figure 14)

			SN54ABTH18502A		SN74ABTH18502A		UNIT	
			MIN	MAX	MIN	MAX		
$f_{\text{clock}}$	Clock frequency	CLKAB or CLKBA	0	100	0	100	MHz	
$t_w$	Pulse duration	CLKAB or CLKBA high or low	3.8		3.5		ns	
		LEAB or LEBA high	3.5		3.5			
$t_{\text{su}}$	Setup time	A before CLKAB $\uparrow$ or B before CLKBA $\uparrow$	3.5		3.5		ns	
		A before LEAB $\downarrow$ or B before LEBA $\downarrow$	CLK high	4.0		3.5		
			CLK low	2		2		
$t_h$	Hold time	A after CLKAB $\uparrow$ or B after CLKBA $\uparrow$	2.9		0.5		ns	
		A after LEAB $\downarrow$ or B after LEBA $\downarrow$	4.0		3			

timing requirements over recommended ranges of supply voltage and operating free-air temperature (unless otherwise noted) (test mode) (see Figure 14)

			SN54ABTH18502A		SN74ABTH18502A		UNIT
			MIN	MAX	MIN	MAX	
$f_{\text{clock}}$	Clock frequency	TCK	0	50	0	50	MHz
$t_w$	Pulse duration	TCK high or low	8		8		ns
$t_{\text{su}}$	Setup time	A, B, CLK, LE, or $\overline{\text{OE}}$ before TCK $\uparrow$	6		6		ns
		TDI before TCK $\uparrow$	4.5		4.5		
		TMS before TCK $\uparrow$	3		3		
$t_h$	Hold time	A, B, CLK, LE, or $\overline{\text{OE}}$ after TCK $\uparrow$	2.9		1.5		ns
		TDI after TCK $\uparrow$	1		1		
		TMS after TCK $\uparrow$	1.5		1.5		
$t_d$	Delay time	Power up to TCK $\uparrow$	50*		50		ns
$t_r$	Rise time	$V_{\text{CC}}$ power up	1*		1		$\mu\text{s}$

\* On products compliant to MIL-PRF-38535, this parameter is not production tested.

**SN54ABTH18502A, SN54ABTH182502A, SN74ABTH18502A, SN74ABTH182502A**  
**SCAN TEST DEVICES**

**WITH 18-BIT UNIVERSAL BUS TRANSCEIVERS**

SCBS164E – AUGUST 1993 – REVISED DECEMBER 1996

**switching characteristics over recommended ranges of supply voltage and operating free-air temperature (unless otherwise noted) (normal mode) (see Figure 14)**

PARAMETER	FROM (INPUT)	TO (OUTPUT)	SN54ABTH18502A					UNIT
			V <sub>CC</sub> = 5 V, T <sub>A</sub> = 25°C			V <sub>CC</sub> = 4.5 V to 5.5 V, T <sub>A</sub> = -55°C to 125°C		
			MIN	TYP	MAX	MIN	MAX	
f <sub>max</sub>	CLKAB or CLKBA		100	130		100		MHz
t <sub>PLH</sub>	A or B	B or A	1.5	3.1	5	1.5	6	ns
t <sub>PHL</sub>			1.5	3.6	5	1.5	6	
t <sub>PLH</sub>	CLKAB or CLKBA	B or A	1.5	3.7	5.2	1.5	6.4	ns
t <sub>PHL</sub>			1.5	3.8	5.2	1.5	6.4	
t <sub>PLH</sub>	LEAB or LEBA	B or A	1.5	3.9	5.5	1.5	6.5	ns
t <sub>PHL</sub>			1.5	3.6	5.5	1.5	6.5	
t <sub>PZH</sub>	$\overline{OEAB}$ or $\overline{OEBA}$	B or A	1.5	4	5.8	1.5	7.5	ns
t <sub>PZL</sub>			1.5	4.2	5.8	1.5	7.5	
t <sub>PHZ</sub>	$\overline{OEAB}$ or $\overline{OEBA}$	B or A	2.8	5.9	7.2	2.8	8.9	ns
t <sub>PLZ</sub>			2	4.5	6	2	7.5	

**switching characteristics over recommended ranges of supply voltage and operating free-air temperature (unless otherwise noted) (normal mode) (see Figure 14)**

PARAMETER	FROM (INPUT)	TO (OUTPUT)	SN74ABTH18502A					UNIT
			V <sub>CC</sub> = 5 V, T <sub>A</sub> = 25°C			V <sub>CC</sub> = 4.5 V to 5.5 V, T <sub>A</sub> = -40°C to 85°C		
			MIN	TYP	MAX	MIN	MAX	
f <sub>max</sub>	CLKAB or CLKBA		100	130		100		MHz
t <sub>PLH</sub>	A or B	B or A	1.5	3.1	5	1.5	5.5	ns
t <sub>PHL</sub>			1.5	3.6	5	1.5	5.5	
t <sub>PLH</sub>	CLKAB or CLKBA	B or A	1.5	3.7	5	1.5	5.5	ns
t <sub>PHL</sub>			1.5	3.8	5	1.5	5.5	
t <sub>PLH</sub>	LEAB or LEBA	B or A	1.5	3.9	5.5	1.5	6	ns
t <sub>PHL</sub>			1.5	3.6	5.5	1.5	6	
t <sub>PZH</sub>	$\overline{OEAB}$ or $\overline{OEBA}$	B or A	1.5	4	5.8	1.5	7	ns
t <sub>PZL</sub>			1.5	4.2	5.8	1.5	7	
t <sub>PHZ</sub>	$\overline{OEAB}$ or $\overline{OEBA}$	B or A	3	5.9	7	3	8	ns
t <sub>PLZ</sub>			2	4.5	6	2	7	



SN54ABTH18502A, SN54ABTH182502A, SN74ABTH18502A, SN74ABTH182502A  
**SCAN TEST DEVICES**  
**WITH 18-BIT UNIVERSAL BUS TRANSCEIVERS**  
SCBS164E – AUGUST 1993 – REVISED DECEMBER 1996

switching characteristics over recommended ranges of supply voltage and operating free-air temperature (unless otherwise noted) (test mode) (see Figure 14)

PARAMETER	FROM (INPUT)	TO (OUTPUT)	V <sub>CC</sub> = 5 V, T <sub>A</sub> = 25°C			SN54ABTH18502A		SN74ABTH18502A		UNIT
			MIN	TYP	MAX	MIN	MAX	MIN	MAX	
f <sub>max</sub>	TCK		50	90		50		50		MHz
t <sub>PLH</sub>	TCK↓	A or B	2.5	7.4	11	2.5	14.5	2.5	13.1	ns
t <sub>PHL</sub>			2.5	7.6	10.8	2.5	14	2.5	12.4	
t <sub>PLH</sub>	TCK↓	TDO	2	3.8	5.1	2	7	2	5.6	ns
t <sub>PHL</sub>			2	4	5.1	2	7	2	5.6	
t <sub>PZH</sub>	TCK↓	A or B	4	8	11.5	4	14.5	4	13.4	ns
t <sub>PZL</sub>			4	8	11.8	4	15	4	13.6	
t <sub>PZH</sub>	TCK↓	TDO	2	3.9	5.7	2	7.5	2	6.6	ns
t <sub>PZL</sub>			2	4.2	6.2	2	8	2	6.9	
t <sub>PHZ</sub>	TCK↓	A or B	4	10.8	13	4	18	4	15	ns
t <sub>PLZ</sub>			3	9.1	13.3	3	17.5	3	15	
t <sub>PHZ</sub>	TCK↓	TDO	3	5.3	6.8	3	8	3	7.2	ns
t <sub>PLZ</sub>			2.5	4.2	5.5	2.5	8	2.5	6.3	

**SN54ABTH18502A, SN54ABTH182502A, SN74ABTH18502A, SN74ABTH182502A**  
**SCAN TEST DEVICES**  
**WITH 18-BIT UNIVERSAL BUS TRANSCEIVERS**

SCBS164E – AUGUST 1993 – REVISED DECEMBER 1996

**recommended operating conditions**

		SN54ABTH182502A		SN74ABTH182502A		UNIT
		MIN	MAX	MIN	MAX	
V <sub>CC</sub>	Supply voltage	4.5	5.5	4.5	5.5	V
V <sub>IH</sub>	High-level input voltage	2		2		V
V <sub>IL</sub>	Low-level input voltage		0.8		0.8	V
V <sub>I</sub>	Input voltage	0	V <sub>CC</sub>	0	V <sub>CC</sub>	V
I <sub>OH</sub>	High-level output current	A port, TDO		-24	-32	mA
		B port		-12	-12	
I <sub>OL</sub>	Low-level output current	A port, TDO		48	64	mA
		B port		12	12	
Δt/Δv	Input transition rise or fall rate		10		10	ns/V
T <sub>A</sub>	Operating free-air temperature	-55	125	-40	85	°C

PRODUCT PREVIEW

PRODUCT PREVIEW information concerns products in the formative or design phase of development. Characteristic data and other specifications are design goals. Texas Instruments reserves the right to change or discontinue these products without notice.



POST OFFICE BOX 655303 • DALLAS, TEXAS 75265

electrical characteristics over recommended operating free-air temperature range (unless otherwise noted)

PARAMETER	TEST CONDITIONS	T <sub>A</sub> = 25°C			SN54ABTH182502A		SN74ABTH182502A		UNIT	
		MIN	TYP†	MAX	MIN	MAX	MIN	MAX		
V <sub>IK</sub>	V <sub>CC</sub> = 4.5 V, I <sub>I</sub> = -18 mA			-1.2		-1.2		-1.2	V	
V <sub>OH</sub>	A port, TDO	V <sub>CC</sub> = 4.5 V, I <sub>OH</sub> = -3 mA		2.5		2.5		2.5	V	
		V <sub>CC</sub> = 5 V, I <sub>OH</sub> = -3 mA		3		3		3		
		V <sub>CC</sub> = 4.5 V	I <sub>OH</sub> = -24 mA	2		2				
	I <sub>OH</sub> = -32 mA		2*				2			
	B port	V <sub>CC</sub> = 4.5 V, I <sub>OH</sub> = -1 mA		3.35		3.3		3.35		
		V <sub>CC</sub> = 5 V, I <sub>OH</sub> = -1 mA		3.85		3.8		3.85		
V <sub>CC</sub> = 4.5 V		I <sub>OH</sub> = -3 mA	3.1		3		3.1			
	I <sub>OH</sub> = -12 mA	2.6*				2.6				
V <sub>OL</sub>	A port, TDO	V <sub>CC</sub> = 4.5 V	I <sub>OL</sub> = 48 mA		0.55		0.55	V		
			I <sub>OL</sub> = 64 mA		0.55*		0.55			
	B port	V <sub>CC</sub> = 4.5 V	I <sub>OL</sub> = 8 mA		0.8		0.65			
			I <sub>OL</sub> = 12 mA		0.8*		0.8			
I <sub>I</sub>	CLK, LE, TCK	V <sub>CC</sub> = 0 to 5.5 V, V <sub>I</sub> = V <sub>CC</sub> or GND			±1		±1	µA		
	A or B ports	V <sub>CC</sub> = 5.5 V, V <sub>I</sub> = V <sub>CC</sub> or GND			±20		±20			
I <sub>IH</sub>	$\overline{OE}$ , TDI, TMS	V <sub>CC</sub> = 5.5 V, V <sub>I</sub> = V <sub>CC</sub>			10		10	µA		
I <sub>IL</sub>	$\overline{OE}$ , TDI, TMS	V <sub>CC</sub> = 5.5 V, V <sub>I</sub> = GND		-40	-150	-40	-150	µA		
I <sub>I(hold)</sub> ‡	A or B ports	V <sub>CC</sub> = 4.5 V	V <sub>I</sub> = 0.8 V	75	220	500		75	500	µA
			V <sub>I</sub> = 2 V	-75	-180	-500		-75	-500	
I <sub>OZH</sub>	TDO	V <sub>CC</sub> = 2.1 V to 5.5 V, V <sub>O</sub> = 2.7 V, $\overline{OE}$ = 2 V			10		10	µA		
I <sub>OZL</sub>	TDO	V <sub>CC</sub> = 2.1 V to 5.5 V, V <sub>O</sub> = 0.5 V, $\overline{OE}$ = 2 V			-10		-10	µA		
I <sub>OZPU</sub>	TDO	V <sub>CC</sub> = 0 to 2.1 V, V <sub>O</sub> = 2.7 V or 0.5 V, $\overline{OE}$ = 0.8 V			±50		±50	µA		
I <sub>OZPD</sub>	TDO	V <sub>CC</sub> = 2.1 V to 0, V <sub>O</sub> = 2.7 V or 0.5 V, $\overline{OE}$ = 0.8 V			±50		±50	µA		
I <sub>off</sub>		V <sub>CC</sub> = 0, V <sub>I</sub> or V <sub>O</sub> ≤ 4.5 V			±100		±100	µA		
I <sub>CEX</sub>	Outputs high	V <sub>CC</sub> = 5.5 V, V <sub>O</sub> = 5.5 V			50		50	µA		
I <sub>O</sub> §	A port, TDO	V <sub>CC</sub> = 5.5 V, V <sub>O</sub> = 2.5 V		-50	-110	-200	-50	-200	mA	
	B port	V <sub>CC</sub> = 5.5 V, V <sub>O</sub> = 2.5 V		-25	-55	-100	-25	-100		
I <sub>CC</sub>	Outputs high	V <sub>CC</sub> = 5.5 V, I <sub>O</sub> = 0, V <sub>I</sub> = V <sub>CC</sub> or GND	A or B ports		1.6	2.2		2.2	mA	
	Outputs low				21	27		27		
	Outputs disabled				0.9	2		2		
ΔI <sub>CC</sub> ¶		V <sub>CC</sub> = 5.5 V, One input at 3.4 V, Other inputs at V <sub>CC</sub> or GND			1.5		1.5	mA		

\* On products compliant to MIL-PRF-38535, this parameter does not apply.

† All typical values are at V<sub>CC</sub> = 5 V.

‡ The parameter I<sub>I(hold)</sub> includes the off-state output leakage current.

§ Not more than one output should be tested at a time, and the duration of the test should not exceed one second.

¶ This is the increase in supply current for each input that is at the specified TTL voltage level rather than V<sub>CC</sub> or GND.

**SN54ABTH18502A, SN54ABTH182502A, SN74ABTH18502A, SN74ABTH182502A**  
**SCAN TEST DEVICES**  
**WITH 18-BIT UNIVERSAL BUS TRANSCEIVERS**

SCBS164E – AUGUST 1993 – REVISED DECEMBER 1996

**electrical characteristics over recommended operating free-air temperature range (unless otherwise noted) (continued)**

PARAMETER		TEST CONDITIONS	T <sub>A</sub> = 25°C			SN54ABTH182502A		SN74ABTH182502A		UNIT
			MIN	TYP†	MAX	MIN	MAX	MIN	MAX	
C <sub>i</sub>	Control inputs	V <sub>I</sub> = 2.5 V or 0.5 V	5							pF
C <sub>io</sub>	A or B ports	V <sub>O</sub> = 2.5 V or 0.5 V	10							pF
C <sub>O</sub>	TDO	V <sub>O</sub> = 2.5 V or 0.5 V	8							pF

† All typical values are at V<sub>CC</sub> = 5 V.

**timing requirements over recommended ranges of supply voltage and operating free-air temperature (unless otherwise noted) (normal mode) (see Figure 14)**

			SN54ABTH182502A		SN74ABTH182502A		UNIT	
			MIN	MAX	MIN	MAX		
f <sub>clock</sub>	Clock frequency	CLKAB or CLKBA	0	100	0	100	MHz	
t <sub>w</sub>	Pulse duration	CLKAB or CLKBA high or low	3.5		3.5		ns	
		LEAB or LEBA high	3.5		3.5			
t <sub>su</sub>	Setup time	A before CLKAB↑ or B before CLKBA↑	3.5		3.5		ns	
		A before LEAB↓ or B before LEBA↓	CLK high	3.5		3.5		
			CLK low	2		2		
t <sub>h</sub>	Hold time	A after CLKAB↑ or B after CLKBA↑	0.5		0.5		ns	
		A after LEAB↓ or B after LEBA↓	3		3			

**timing requirements over recommended ranges of supply voltage and operating free-air temperature (unless otherwise noted) (test mode) (see Figure 14)**

			SN54ABTH182502A		SN74ABTH182502A		UNIT
			MIN	MAX	MIN	MAX	
f <sub>clock</sub>	Clock frequency	TCK	0	50	0	50	MHz
t <sub>w</sub>	Pulse duration	TCK high or low	8		8		ns
t <sub>su</sub>	Setup time	A, B, CLK, LE, or $\overline{OE}$ before TCK↑	6		6		ns
		TDI before TCK↑	4.5		4.5		
		TMS before TCK↑	3		3		
t <sub>h</sub>	Hold time	A, B, CLK, LE, or $\overline{OE}$ after TCK↑	1.5		1.5		ns
		TDI after TCK↑	1		1		
		TMS after TCK↑	1.5		1.5		
t <sub>d</sub>	Delay time	Power up to TCK↑	50		50		ns
t <sub>r</sub>	Rise time	V <sub>CC</sub> power up	1		1		μs

PRODUCT PREVIEW information concerns products in the formative or design phase of development. Characteristic data and other specifications are design goals. Texas Instruments reserves the right to change or discontinue these products without notice.



POST OFFICE BOX 655303 • DALLAS, TEXAS 75265

switching characteristics over recommended ranges of supply voltage and operating free-air temperature (unless otherwise noted) (normal mode) (see Figure 14)

PARAMETER	FROM (INPUT)	TO (OUTPUT)	V <sub>CC</sub> = 5 V, T <sub>A</sub> = 25°C			SN54ABTH182502A		SN74ABTH182502A		UNIT
			MIN	TYP	MAX	MIN	MAX	MIN	MAX	
f <sub>max</sub>	CLKAB or CLKBA		100	130		100		100		MHz
t <sub>PLH</sub>	A	B	1.5	3.1	5	1.5	6	1.5	5.5	ns
t <sub>PHL</sub>			1.5	3.6	5.6	1.5	6.4	1.5	6.2	
t <sub>PLH</sub>	B	A	1.5	3.1	5	1.5	6	1.5	5.5	ns
t <sub>PHL</sub>			1.5	3.6	5	1.5	6	1.5	5.5	
t <sub>PLH</sub>	CLKAB	B	1.5	3.7	5.4	1.5	6.2	1.5	6.1	ns
t <sub>PHL</sub>			1.5	4	5.8	1.5	6.4	1.5	6.2	
t <sub>PLH</sub>	CLKBA	A	1.5	3.7	5	1.5	6	1.5	5.5	ns
t <sub>PHL</sub>			1.5	3.8	5	1.5	6	1.5	5.5	
t <sub>PLH</sub>	LEAB	B	1.5	3.9	5.6	1.5	6.5	1.5	6.3	ns
t <sub>PHL</sub>			1.5	3.6	5.6	1.5	6.5	1.5	6.2	
t <sub>PLH</sub>	LEBA	A	1.5	3.9	5.5	1.5	6.5	1.5	6	ns
t <sub>PHL</sub>			1.5	3.6	5.5	1.5	6.5	1.5	6	
t <sub>PZH</sub>	OEAB or OEBA	B or A	1.5	4	5.8	1.5	7.5	1.5	7	ns
t <sub>PZL</sub>			1.5	4.2	5.8	1.5	7.5	1.5	7	
t <sub>PHZ</sub>	$\overline{OEAB}$ or $\overline{OEBA}$	B or A	3	5.9	7	3	8.5	3	8	ns
t <sub>PLZ</sub>			2	4.5	6	2	7.5	2	7	

switching characteristics over recommended ranges of supply voltage and operating free-air temperature (unless otherwise noted) (test mode) (see Figure 14)

PARAMETER	FROM (INPUT)	TO (OUTPUT)	V <sub>CC</sub> = 5 V, T <sub>A</sub> = 25°C			SN54ABTH182502A		SN74ABTH182502A		UNIT
			MIN	TYP	MAX	MIN	MAX	MIN	MAX	
f <sub>max</sub>	TCK		50	90		50		50		MHz
t <sub>PLH</sub>	TCK↓	A or B	2.5	7.4	11	2.5	14.5	2.5	13.1	ns
t <sub>PHL</sub>			2.5	7.6	10.8	2.5	14	2.5	12.4	
t <sub>PLH</sub>	TCK↓	TDO	2	3.8	5.1	2	7	2	5.6	ns
t <sub>PHL</sub>			2	4	5.1	2	7	2	5.6	
t <sub>PZH</sub>	TCK↓	A or B	4	8	11.5	4	14.5	4	13.4	ns
t <sub>PZL</sub>			4	8	11.8	4	15	4	13.6	
t <sub>PZH</sub>	TCK↓	TDO	2	3.9	5.7	2	7.5	2	6.6	ns
t <sub>PZL</sub>			2	4.2	6.2	2	8	2	6.9	
t <sub>PHZ</sub>	TCK↓	A or B	4	10.8	13	4	18	4	15	ns
t <sub>PLZ</sub>			3	9.1	13.3	3	17.5	3	15	
t <sub>PHZ</sub>	TCK↓	TDO	3	5.3	6.8	3	8	3	7.2	ns
t <sub>PLZ</sub>			2.5	4.2	5.5	2.5	8	2.5	6.3	

PARAMETER MEASUREMENT INFORMATION

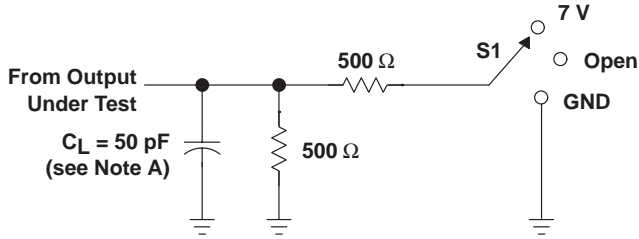

LOAD CIRCUIT

TEST	S1
$t_{PLH}/t_{PHL}$	Open
$t_{PLZ}/t_{PZL}$	7 V
$t_{PHZ}/t_{PZH}$	Open

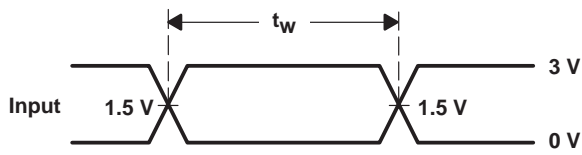

VOLTAGE WAVEFORMS  
PULSE DURATION

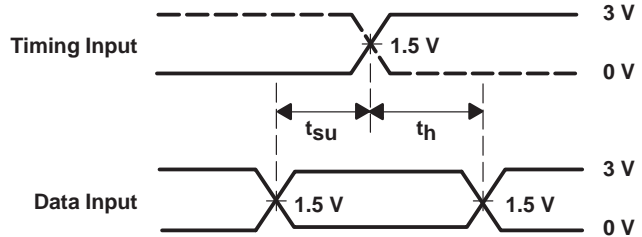

VOLTAGE WAVEFORMS  
SETUP AND HOLD TIMES

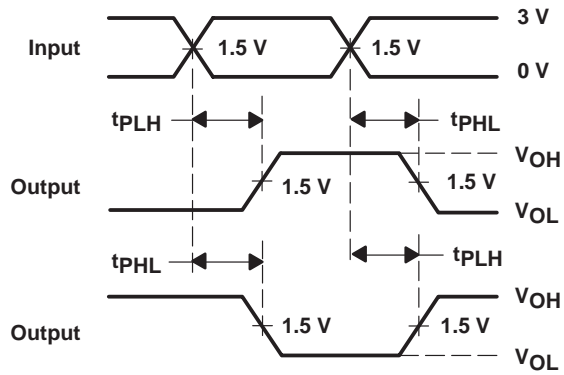

VOLTAGE WAVEFORMS  
PROPAGATION DELAY TIMES  
INVERTING AND NONINVERTING OUTPUTS

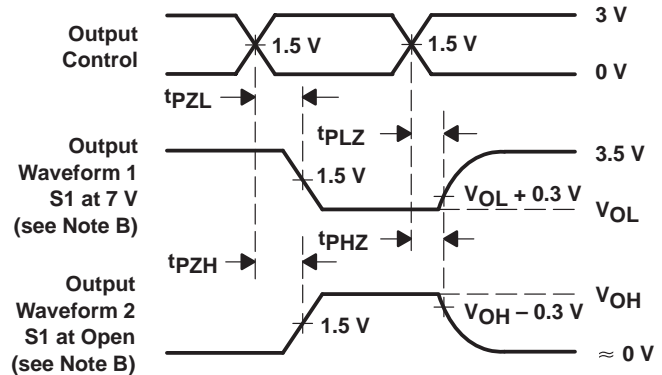

VOLTAGE WAVEFORMS  
ENABLE AND DISABLE TIMES  
LOW- AND HIGH-LEVEL ENABLING

- NOTES: A.  $C_L$  includes probe and jig capacitance.  
 B. Waveform 1 is for an output with internal conditions such that the output is low except when disabled by the output control. Waveform 2 is for an output with internal conditions such that the output is high except when disabled by the output control.  
 C. All input pulses are supplied by generators having the following characteristics:  $PRR \leq 10 \text{ MHz}$ ,  $Z_O = 50 \Omega$ ,  $t_r \leq 2.5 \text{ ns}$ ,  $t_f \leq 2.5 \text{ ns}$ .  
 D. The outputs are measured one at a time with one transition per measurement.

Figure 14. Load Circuit and Voltage Waveforms

**PACKAGING INFORMATION**

Orderable Device	Status (1)	Package Type	Package Drawing	Pins	Package Qty	Eco Plan (2)	Lead/Ball Finish (6)	MSL Peak Temp (3)	Op Temp (°C)	Device Marking (4/5)	Samples
5962-9561401QXA	ACTIVE	CFP	HV	68	1	TBD	Call TI	N / A for Pkg Type	-55 to 125	5962-9561401QX A SNJ54ABTH18502 AHV	<a href="#">Samples</a>
SN74ABTH182502APM	ACTIVE	LQFP	PM	64	160	Green (RoHS & no Sb/Br)	CU NIPDAU	Level-3-260C-168 HR	-40 to 85	ABTH182502A	<a href="#">Samples</a>
SN74ABTH18502APM	ACTIVE	LQFP	PM	64	160	Green (RoHS & no Sb/Br)	CU NIPDAU	Level-3-260C-168 HR	-40 to 85	ABTH18502A	<a href="#">Samples</a>
SN74ABTH18502APMR	ACTIVE	LQFP	PM	64	1000	Green (RoHS & no Sb/Br)	CU NIPDAU	Level-3-260C-168 HR	-40 to 85	ABTH18502A	<a href="#">Samples</a>
SNJ54ABTH18502AHV	ACTIVE	CFP	HV	68	1	TBD	Call TI	N / A for Pkg Type	-55 to 125	5962-9561401QX A SNJ54ABTH18502 AHV	<a href="#">Samples</a>

(1) The marketing status values are defined as follows:

**ACTIVE:** Product device recommended for new designs.

**LIFEBUY:** TI has announced that the device will be discontinued, and a lifetime-buy period is in effect.

**NRND:** Not recommended for new designs. Device is in production to support existing customers, but TI does not recommend using this part in a new design.

**PREVIEW:** Device has been announced but is not in production. Samples may or may not be available.

**OBSOLETE:** TI has discontinued the production of the device.

(2) Eco Plan - The planned eco-friendly classification: Pb-Free (RoHS), Pb-Free (RoHS Exempt), or Green (RoHS & no Sb/Br) - please check <http://www.ti.com/productcontent> for the latest availability information and additional product content details.

**TBD:** The Pb-Free/Green conversion plan has not been defined.

**Pb-Free (RoHS):** TI's terms "Lead-Free" or "Pb-Free" mean semiconductor products that are compatible with the current RoHS requirements for all 6 substances, including the requirement that lead not exceed 0.1% by weight in homogeneous materials. Where designed to be soldered at high temperatures, TI Pb-Free products are suitable for use in specified lead-free processes.

**Pb-Free (RoHS Exempt):** This component has a RoHS exemption for either 1) lead-based flip-chip solder bumps used between the die and package, or 2) lead-based die adhesive used between the die and leadframe. The component is otherwise considered Pb-Free (RoHS compatible) as defined above.

**Green (RoHS & no Sb/Br):** TI defines "Green" to mean Pb-Free (RoHS compatible), and free of Bromine (Br) and Antimony (Sb) based flame retardants (Br or Sb do not exceed 0.1% by weight in homogeneous material)

(3) MSL, Peak Temp. - The Moisture Sensitivity Level rating according to the JEDEC industry standard classifications, and peak solder temperature.

(4) There may be additional marking, which relates to the logo, the lot trace code information, or the environmental category on the device.

(5) Multiple Device Markings will be inside parentheses. Only one Device Marking contained in parentheses and separated by a "-" will appear on a device. If a line is indented then it is a continuation of the previous line and the two combined represent the entire Device Marking for that device.

(6) Lead/Ball Finish - Orderable Devices may have multiple material finish options. Finish options are separated by a vertical ruled line. Lead/Ball Finish values may wrap to two lines if the finish value exceeds the maximum column width.

**Important Information and Disclaimer:**The information provided on this page represents TI's knowledge and belief as of the date that it is provided. TI bases its knowledge and belief on information provided by third parties, and makes no representation or warranty as to the accuracy of such information. Efforts are underway to better integrate information from third parties. TI has taken and continues to take reasonable steps to provide representative and accurate information but may not have conducted destructive testing or chemical analysis on incoming materials and chemicals. TI and TI suppliers consider certain information to be proprietary, and thus CAS numbers and other limited information may not be available for release.

In no event shall TI's liability arising out of such information exceed the total purchase price of the TI part(s) at issue in this document sold by TI to Customer on an annual basis.

**OTHER QUALIFIED VERSIONS OF SN54ABTH18502A, SN74ABTH18502A :**

● Catalog: [SN74ABTH18502A](#)

● Military: [SN54ABTH18502A](#)

NOTE: Qualified Version Definitions:

- Catalog - TI's standard catalog product
- Military - QML certified for Military and Defense Applications

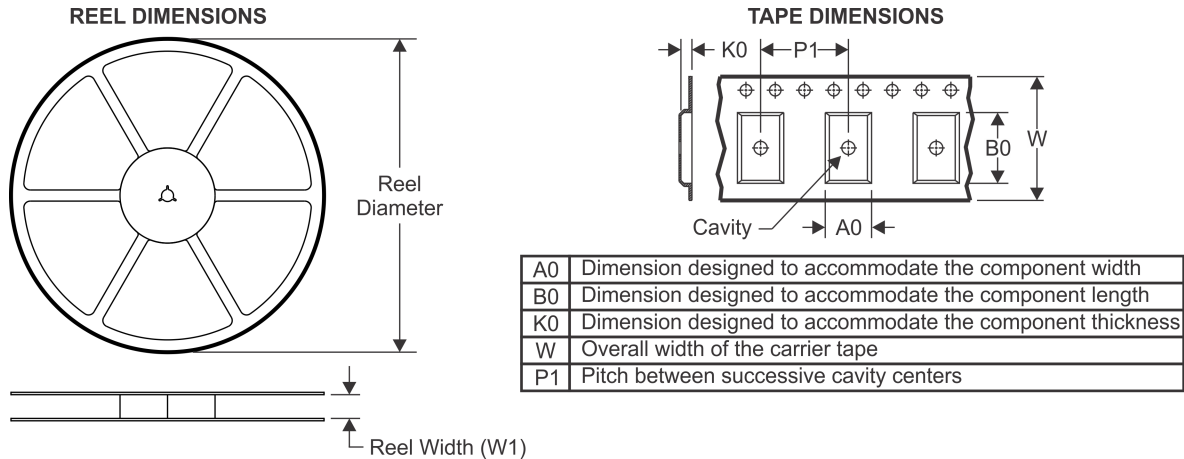
**TAPE AND REEL INFORMATION**

**QUADRANT ASSIGNMENTS FOR PIN 1 ORIENTATION IN TAPE**

\*All dimensions are nominal

Device	Package Type	Package Drawing	Pins	SPQ	Reel Diameter (mm)	Reel Width W1 (mm)	A0 (mm)	B0 (mm)	K0 (mm)	P1 (mm)	W (mm)	Pin1 Quadrant
SN74ABTH18502APMR	LQFP	PM	64	1000	330.0	24.4	13.0	13.0	2.1	16.0	24.0	Q2

TAPE AND REEL BOX DIMENSIONS



\*All dimensions are nominal

Device	Package Type	Package Drawing	Pins	SPQ	Length (mm)	Width (mm)	Height (mm)
SN74ABTH18502APMR	LQFP	PM	64	1000	350.0	350.0	43.0



PM (S-PQFP-G64)

PLASTIC QUAD FLATPACK

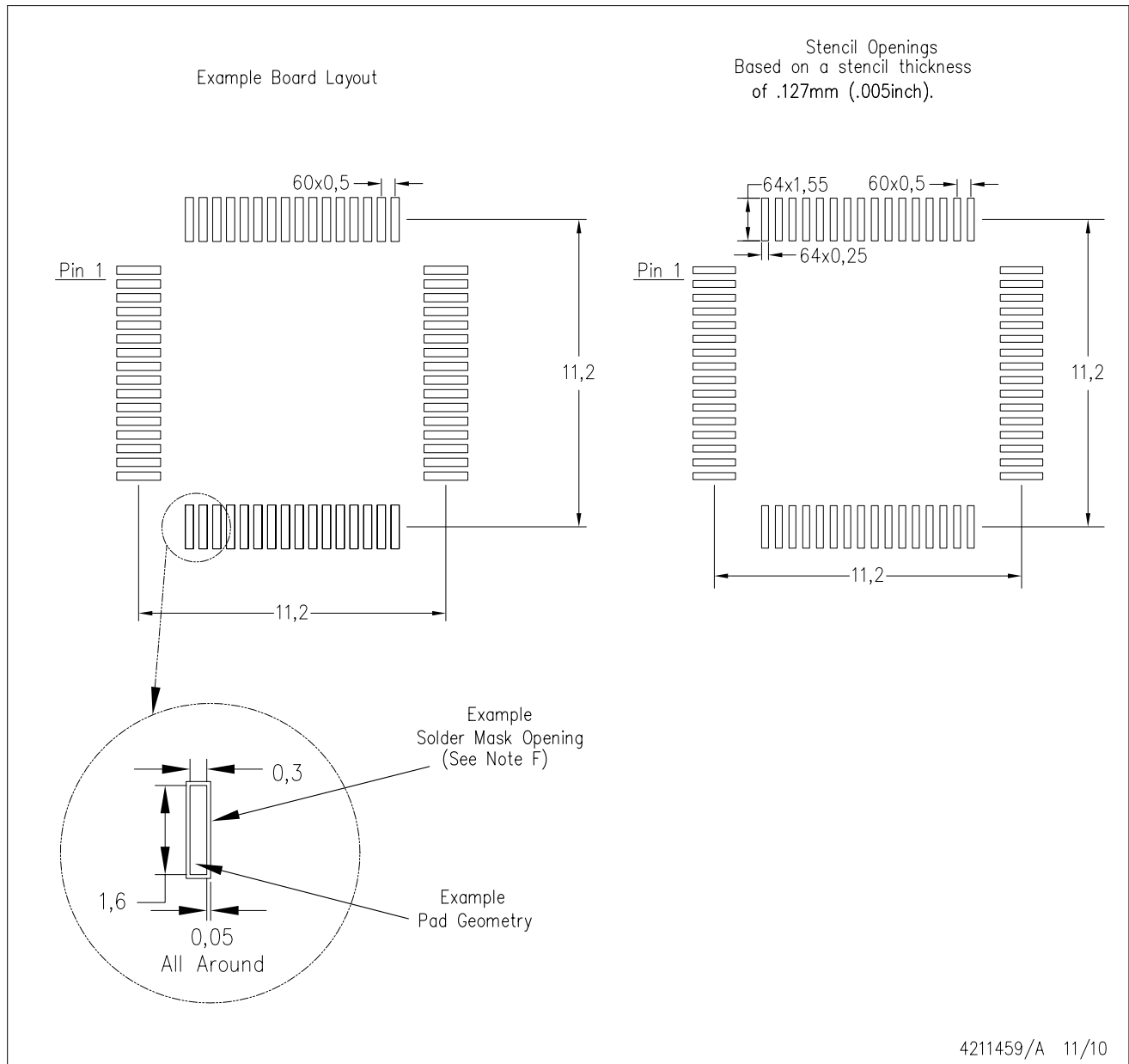

- NOTES:
- A. All linear dimensions are in millimeters.
  - B. This drawing is subject to change without notice.
  - C. Laser cutting apertures with trapezoidal walls and also rounding corners will offer better paste release. Customers should contact their board assembly site for stencil design recommendations. Example stencil design based on a 50% volumetric metal load solder paste. Refer to IPC-7525 for other stencil recommendations.
  - D. Customers should contact their board fabrication site for solder mask tolerances between and around signal pads.

HV (S-QQFP-F68)

CERAMIC QUAD FLATPACK

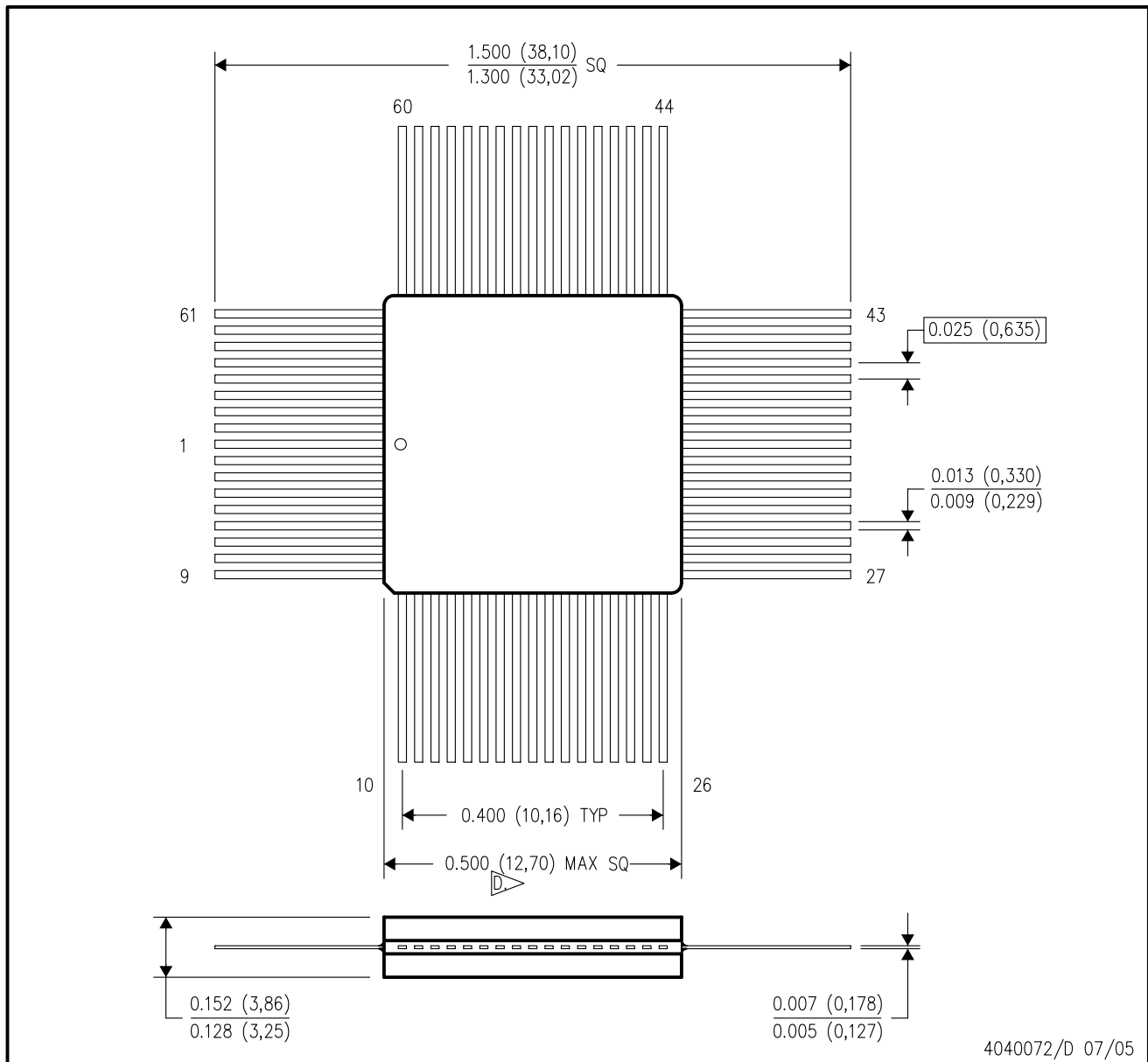

- NOTES:
- A. All linear dimensions are in inches (millimeters).
  - B. This drawing is subject to change without notice.
  - C. This package can be hermetically sealed with a ceramic lid using glass frit.
  - D. This dimension allows for package edge anomalies caused by material protrusion, such as rough ceramic, misaligned ceramic layers and lids, meniscus, and glass overrun.

## IMPORTANT NOTICE AND DISCLAIMER

TI PROVIDES TECHNICAL AND RELIABILITY DATA (INCLUDING DATASHEETS), DESIGN RESOURCES (INCLUDING REFERENCE DESIGNS), APPLICATION OR OTHER DESIGN ADVICE, WEB TOOLS, SAFETY INFORMATION, AND OTHER RESOURCES "AS IS" AND WITH ALL FAULTS, AND DISCLAIMS ALL WARRANTIES, EXPRESS AND IMPLIED, INCLUDING WITHOUT LIMITATION ANY IMPLIED WARRANTIES OF MERCHANTABILITY, FITNESS FOR A PARTICULAR PURPOSE OR NON-INFRINGEMENT OF THIRD PARTY INTELLECTUAL PROPERTY RIGHTS.

These resources are intended for skilled developers designing with TI products. You are solely responsible for (1) selecting the appropriate TI products for your application, (2) designing, validating and testing your application, and (3) ensuring your application meets applicable standards, and any other safety, security, or other requirements. These resources are subject to change without notice. TI grants you permission to use these resources only for development of an application that uses the TI products described in the resource. Other reproduction and display of these resources is prohibited. No license is granted to any other TI intellectual property right or to any third party intellectual property right. TI disclaims responsibility for, and you will fully indemnify TI and its representatives against, any claims, damages, costs, losses, and liabilities arising out of your use of these resources.

TI's products are provided subject to TI's Terms of Sale ([www.ti.com/legal/termsofsale.html](http://www.ti.com/legal/termsofsale.html)) or other applicable terms available either on [ti.com](http://ti.com) or provided in conjunction with such TI products. TI's provision of these resources does not expand or otherwise alter TI's applicable warranties or warranty disclaimers for TI products.

Mailing Address: Texas Instruments, Post Office Box 655303, Dallas, Texas 75265  
Copyright © 2019, Texas Instruments Incorporated

## Looking for pricing, stock, or lifecycle information?

Click below to explore more details on WIN SOURCE:

 [View SN74ABTH18502APMR on WIN SOURCE](#)

 [Texas Instruments](#) Information

## Optimize Your Supply Chain with WIN SOURCE Solutions

-  Global Sourcing Solution
-  Obsolete Management
-  Cost Control Management
-  Shortage Management
-  Alternative Solution
-  Excess Inventory Management