



THE DATASHEET OF SN65HVD51DR



SN65HVD5x High Output Full-Duplex RS-485 Drivers and Receivers

1 Features

- 1/8 Unit-load option available (up to 256 nodes on the bus)
- Bus-pin ESD protection exceeds 15 kV HBM
- Optional driver output transition times for signaling rates⁽¹⁾ of 1 Mbps, 5 Mbps and 25 Mbps
- Low-current standby mode < 1 μ A
- Glitch-free power-up and power-down bus I/Os
- Bus idle, open, and short circuit failsafe
- Designed for RS-422 and RS485 networks
- 3.3-V Devices available, SN65HVD30-35 ¹

2 Applications

- Utility meters
- Chassis-to-chassis interconnects
- DTE/DCE Interfaces
- Industrial, process, and building automation
- Point-of-sale (POS) terminals and networks

3 Description

The SN65HVD5X devices are 3-state differential line drivers and differential-input line receivers that operate with a 5-V power supply. Each driver and receiver has separate input and output pins for full-duplex bus communication designs. They are designed for balanced transmission lines and interoperation with ANSI TIA/EIA-485A, TIA/EIA-422-B, ITU-T v.11 and ISO 8482:1993 standard-compliant devices.

The SN65HVD50, SN65HVD51, and SN65HVD52 are fully enabled with no external enabling pins.

The SN65HVD53, SN65HVD54, and SN65HVD55 have active-high driver enables and active-low receiver enables. A low, less than 1 μ A, standby current is achieved by disabling both the driver and receiver.

All devices are characterized for operation from -40°C to 85°C .

The high output feature of the SN65HVD5x provides more noise margin than the typical RS-485 drivers. The extra noise margin makes applications in long cable and harsh noise environments possible.

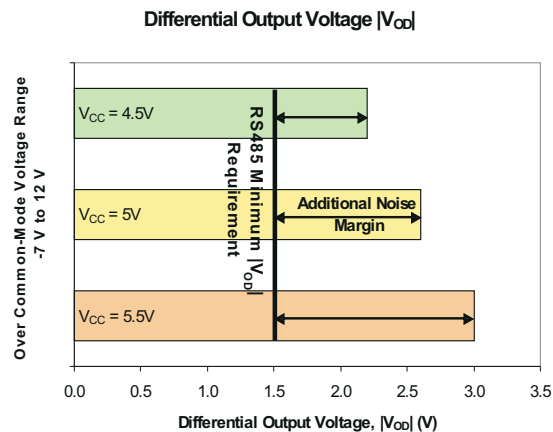

¹ The signaling rate of a line is the number of voltage transitions that are made per second expressed in the units bps (bits per second).



Table of Contents

1 Features	1	8 Parameter Measurement Information	16
2 Applications	1	9 Device Information	19
3 Description	1	9.1 LI-Power Standby Mode.....	19
4 Revision History	2	9.2 Function Tables.....	20
5 Available Options	4	9.3 Equivalent Input and Output Schematic Diagrams...	21
6 Pin Configurations	5	10 Application and Implementation	22
7 Specifications	6	10.1 Thermal Characteristics of IC Packages.....	22
7.1 Absolute Maximum Ratings.....	6	11 Device and Documentation Support	24
7.2 Recommended Operating Conditions.....	6	11.1 Receiving Notification of Documentation Updates..	24
7.3 Electrostatic Discharge Protection.....	6	11.2 Support Resources.....	24
7.4 Driver Electrical Characteristics.....	7	11.3 Trademarks.....	24
7.5 Driver Switching Characteristics.....	8	11.4 Electrostatic Discharge Caution.....	24
7.6 Receiver Electrical Characteristics.....	9	11.5 Glossary.....	24
7.7 Receiver Switching Characteristics.....	10	12 Mechanical, Packaging, and Orderable	
7.8 Thermal Characteristics.....	11	Information	24
7.9 Typical Characteristics.....	12		

4 Revision History

NOTE: Page numbers for previous revisions may differ from page numbers in the current version.

Changes from Revision E (October 2009) to Revision F (March 2023)	Page
• Changed the <i>Thermal Characteristics</i> table.....	11
• Changed the <i>Typical Characteristics</i>	12

Changes from Revision D (June 2008) to Revision E (October 2009)	Page
• Changed text of feature bullet From: 3.3-V Devices Available, SN65HVD30-39 To: 3.3-V Devices Available, SN65HVD30-35.....	1
• Deleted all references to SN65HVD56, SN65HVD57, SN65HVD58, SN65HVD59 throughout the data sheet.	1
• Deleted RECEIVER EQUALIZATION CHARACTERISTICS from the data sheet.....	4
• Changed scale of Figure 7-6	12
• Changed scale of Figure 7-7	12
• Added Figure 7-11	12
• Changed Figure 10-1	22

Changes from Revision C (July 2006) to Revision D (June 2008)	Page
• Changed text of feature bullet From: Meets or Exceeds the Requirements of ANSI TIA/EIA-485-A and RS-422 Compatible To: Designed for RS-422 and RS485 Networks.....	1

Changes from Revision B (May 2006) to Revision C (July 2006)	Page
• Added Figure 7-10	12
• Added Figure 7-12	12

Changes from Revision A (February 2006) to Revision B (May 2006)	Page
• Added $t_{sk(p)}$ TYP Values.....	8
• Deleted $t_{sk(p)}$ MAX Values.....	8

Changes from Revision * (September 2005) to Revision A (February 2006)

Page

• Changed the Description and illustration.....	1
• Changed device SN65HVD50, 51, and 52 SOIC Markings From Preview To 65HVD50, 65HVD51, and 65HVD52	4
• Changed $V_{OD(RING)}$ Max value From $0.05 V_{OD(SS)} $ To: 10% with the associated note.....	7
• Changed t_r MIN value From: 25 ns To: 20 ns.....	8
• Changed t_f MIN value From: 25 ns To: 20 ns.....	8
• Changed Supply Current - HVD50 MAX value From 8 mA To: 2.7 mA.....	9
• Changed section LOW-POWER SHUTDOWN MODE To: LOW-POWER STANDBY MODE.....	19

5 Available Options

SIGNALING RATE	UNIT LOADS	ENABLES	BASE PART NUMBER	SOIC MARKING
25 Mbps	1/2	No	SN65HVD50	65HVD50
5 Mbps	1/8	No	SN65HVD51	65HVD51
1 Mbps	1/8	No	SN65HVD52	65HVD52
25 Mbps	1/2	Yes	SN65HVD53	65HVD53
5 Mbps	1/8	Yes	SN65HVD54	65HVD54
1 Mbps	1/8	Yes	SN65HVD55	65HVD55

6 Pin Configurations

D PACKAGE (TOP VIEW)

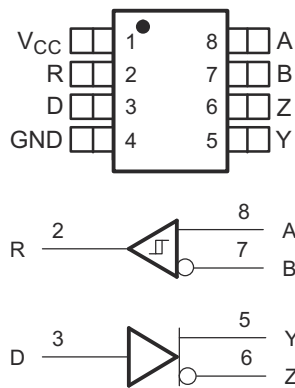

Figure 6-1. SN65HVD50, SN65HVD51, SN65HVD52

D PACKAGE (TOP VIEW)

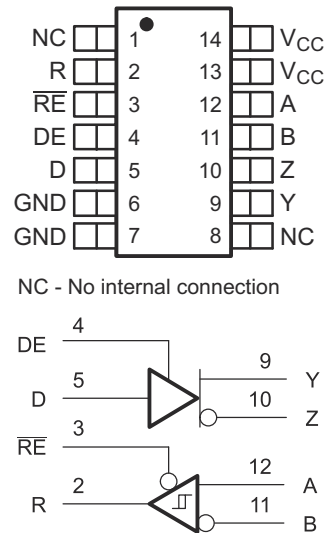

Figure 6-2. SN65HVD53, SN65HVD54, SN65HVD55

7 Specifications

7.1 Absolute Maximum Ratings

over operating free-air temperature range (unless otherwise noted)^{(1) (2)}

		UNIT
V_{CC}	Supply voltage range	-0.3 V to 6 V
$V_{(A)}, V_{(B)}, V_{(Y)}, V_{(Z)}$	Voltage range at any bus terminal (A, B, Y, Z)	-9 V to 14 V
$V_{(TRANS)}$	Voltage input, transient pulse through 100 Ω . See Figure 8-12 (A, B, Y, Z) ⁽³⁾	-50 to 50 V
V_I	Voltage input range (D, DE, \overline{RE})	-0.5 V to 7 V
$P_{D(cont)}$	Continuous total power dissipation	Internally limited ⁽⁴⁾
I_O	Output current (receiver output only, R)	11 mA

- (1) Stresses beyond those listed under absolute maximum ratings may cause permanent damage to the device. These are stress ratings only, and functional operation of the device at these or any other conditions beyond those indicated under recommended operating conditions is not implied. Exposure to absolute-maximum-rated conditions for extended periods may affect device reliability.
- (2) All voltage values, except differential I/O bus voltages, are with respect to network ground terminal.
- (3) This tests survivability only and the output state of the receiver is not specified.
- (4) The thermal shutdown typically occurs when the junction temperature reaches 165°C.

7.2 Recommended Operating Conditions

over operating free-air temperature range (unless otherwise noted)

			MIN	NOM	MAX	UNIT
V_{CC}	Supply voltage		4.5		5.5	V
V_I or V_{IC}	Voltage at any bus terminal (separately or common mode)		-7 ⁽¹⁾		12	
$1/t_{UI}$	Signaling rate	SN65HVD50, SN65HVD53			25	Mbps
		SN65HVD51, SN65HVD54			5	
		SN65HVD52, SN65HVD55			1	
R_L	Differential load resistance		54	60		Ω
V_{IH}	High-level input voltage	D, DE, \overline{RE}	2		V_{CC}	V
V_{IL}	Low-level input voltage	D, DE, \overline{RE}	0		0.8	
V_{ID}	Differential input voltage		-12		12	
I_{OH}	High-level output current	Driver	-60			
		Receiver	-8			
I_{OL}	Low-level output current	Driver			60	mA
		Receiver			8	
T_J ⁽²⁾	Junction temperature		-40		150	°C

- (1) The algebraic convention, in which the least positive (most negative) limit is designated as minimum is used in this data sheet.
- (2) See thermal characteristics table for information regarding this specification.

7.3 Electrostatic Discharge Protection

PARAMETER	TEST CONDITIONS	MIN	TYP ⁽¹⁾	MAX	UNIT
Human body model	Bus terminals and GND		± 16		kV
Human body model ⁽²⁾	All pins		± 4		
Charged-device-model ⁽³⁾	All pins		± 1		

- (1) All typical values at 25°C and with a 5-V supply.
- (2) Tested in accordance with JEDEC Standard 22, Test Method A114-A.
- (3) Tested in accordance with JEDEC Standard 22, Test Method C101.

7.4 Driver Electrical Characteristics

over recommended operating conditions unless otherwise noted

PARAMETER		TEST CONDITIONS		MIN	TYP ⁽¹⁾	MAX	UNIT		
$V_{I(K)}$	Input clamp voltage	$I_I = -18$ mA		-1.5					
$ V_{OD(SS)} $	Steady-state differential output voltage	$I_O = 0$		4		V_{CC}	V		
		$R_L = 54 \Omega$, See Figure 8-1 (RS-485)		1.7	2.6				
		$R_L = 100 \Omega$, See Figure 8-1 (RS-422)		2.4	3.2				
		$V_{test} = -7$ V to 12 V, See Figure 8-2		1.6					
$\Delta V_{OD(SS)} $	Change in magnitude of steady-state differential output voltage between states	$R_L = 54 \Omega$, See Figure 8-1 and Figure 8-2		-0.2		0.2			
$V_{OD(RING)}$	Differential Output Voltage overshoot and undershoot	$R_L = 54 \Omega$, $C_L = 50$ pF, See Figure 8-5 See Figure 8-3 for definition				10% ⁽²⁾			
$V_{OC(PP)}$	Peak-to-peak common-mode output voltage	HVD50, HVD53			0.5				
		HVD51, HVD54		See Figure 8-4		0.4			
		HVD52, HVD55			0.4				
$V_{OC(SS)}$	Steady-state common-mode output voltage	See Figure 8-4		2.2		3.3			
$\Delta V_{OC(SS)}$	Change in steady-state common-mode output voltage			-0.1		0.1			
$I_{Z(Z)}$ or $I_{Y(Z)}$	High-impedance state output current	HVD50, HVD51, HVD52	$V_{CC} = 0$ V, V_Z or $V_Y = 12$ V, Other input at 0 V				90	μ A	
			$V_{CC} = 0$ V, V_Z or $V_Y = -7$ V, Other input at 0 V		-10				
		HVD53, HVD54, HVD55	$V_{CC} = 5$ V or 0 V, DE = 0 V, V_Z or $V_Y = 12$ V		Other input at 0 V				90
			$V_{CC} = 5$ V or 0 V, DE = 0 V, V_Z or $V_Y = -7$ V			-10			
$I_{Z(S)}$ or $I_{Y(S)}$	Short-circuit output current ⁽³⁾	V_Z or $V_Y = -7$ V		Other input at 0 V	-250	250	mA		
		V_Z or $V_Y = 12$ V			-250	250			
I_I	Input current	D, DE		0		100	μ A		
$C_{(OD)}$	Differential output capacitance	$V_{OD} = 0.4 \sin(4E6\pi t) + 0.5$ V, DE at 0 V			16		pF		

(1) All typical values are at 25°C and with a 5-V supply.

(2) 10% of the peak-to-peak differential output voltage swing, per TIA/EIA-485

(3) Under some conditions of short-circuit to negative voltages, output currents exceeding the ANSI TIA/EIA-485-A maximum current of 250 mA may occur. Continuous exposure may affect device reliability.

7.5 Driver Switching Characteristics

over recommended operating conditions unless otherwise noted

PARAMETER		TEST CONDITIONS	MIN	TYP ⁽¹⁾	MAX	UNIT
t _{PLH}	Propagation delay time, low-to-high-level output	HVD50, HVD53	4	8	12	ns
		HVD51, HVD54	20	29	46	
		HVD52, HVD55	90	143	230	
t _{PHL}	Propagation delay time, high-to-low-level output	HVD50, HVD53	4	8	12	ns
		HVD51, HVD54	20	30	46	
		HVD52, HVD55	90	143	230	
t _r	Differential output signal rise time	HVD50, HVD53	3	6	12	ns
		HVD51, HVD54	20	34	60	
		HVD52, HVD55	120	197	300	
t _f	Differential output signal fall time	HVD50, HVD53	3	6	11	ns
		HVD51, HVD54	20	33	60	
		HVD52, HVD55	120	192	300	
t _{sk(p)}	Pulse skew (t _{PHL} – t _{PLH})	HVD50, HVD53		1.4		ns
		HVD51, HVD54		1.6		
		HVD52, HVD55		7.4		
t _{sk(pp)} ⁽²⁾	Part-to-part skew	HVD50, HVD53		1		ns
		HVD51, HVD54		4		
		HVD52, HVD55		22		
t _{PZH1}	Propagation delay time, high-impedance-to-high-level output	HVD53			30	ns
		HVD54			180	
		HVD55			380	
t _{PHZ}	Propagation delay time, high-level-to-high-impedance output	HVD53			16	ns
		HVD54			40	
		HVD55			110	
t _{PZL1}	Propagation delay time, high-impedance-to-low-level output	HVD53			23	ns
		HVD54			200	
		HVD55			420	
t _{PLZ}	Propagation delay time, low-level-to-high-impedance output	HVD53			19	ns
		HVD54			70	
		HVD55			160	
t _{PZH2}	Propagation delay time, standby-to-high-level output	R _L = 110 Ω, \overline{RE} at 3 V, See Figure 8-6 D = 3 V and S1 = Y, D = 0 V and S1 = Z			3300	ns
t _{PZL2}	Propagation delay time, standby-to-low-level output	R _L = 110 Ω, \overline{RE} at 3 V, See Figure 8-7 D = 3 V and S1 = Z, D = 0 V and S1 = Y			3300	ns

(1) All typical values are at 25°C and with a 5-V supply.

(2) t_{sk(pp)} is the magnitude of the difference in propagation delay times between any specified terminals of two devices when both devices operate with the same supply voltages, at the same temperature, and have identical packages and test circuits.

7.6 Receiver Electrical Characteristics

over recommended operating conditions unless otherwise noted

PARAMETER		TEST CONDITIONS		MIN	TYP ⁽¹⁾	MAX	UNIT	
V_{IT+}	Positive-going differential input threshold voltage	$I_O = -8$ mA				-0.02	V	
V_{IT-}	Negative-going differential input threshold voltage	$I_O = 8$ mA		-0.2				
V_{hys}	Hysteresis voltage ($V_{IT+} - V_{IT-}$)				50		mV	
V_{IK}	Enable-input clamp voltage	$I_I = -18$ mA		-1.5			V	
V_O	Output voltage	$V_{ID} = 200$ mV, $I_O = -8$ mA, See Figure 8-8		4			V	
		$V_{ID} = -200$ mV, $I_O = 8$ mA, See Figure 8-8				0.3		
$I_{O(Z)}$	High-impedance-state output current	$V_O = 0$ or V_{CC} RE at V_{CC}		-1		1	μ A	
I_A or I_B	Bus input current	HVD50, HVD53,	V_A or $V_B = 12$ V	Other input at 0 V		0.19	0.3	mA
			V_A or $V_B = 12$ V, $V_{CC} = 0$ V			0.24	0.4	
			V_A or $V_B = -7$ V			-0.35	-0.19	
			V_A or $V_B = -7$ V, $V_{CC} = 0$ V			-0.25	-0.14	
		HVD51, HVD52, HVD54, HVD55	V_A or $V_B = 12$ V	Other input at 0 V		0.05	0.1	mA
			V_A or $V_B = 12$ V, $V_{CC} = 0$ V			0.06	0.1	
			V_A or $V_B = -7$ V			-0.1	-0.05	
			V_A or $V_B = -7$ V, $V_{CC} = 0$ V			-0.1	-0.03	
I_{IH}	Input current, RE	$V_{IH} = 2$ V		-60			μ A	
		$V_{IL} = 0.8$ V		-60			μ A	
C_{ID}	Differential input capacitance	$V_{ID} = 0.4 \sin(4E6\pi t) + 0.5$ V, DE at 0 V			16		pF	
Supply Current								
I_{CC}	Supply current	HVD50	D at 0 V or V_{CC} and No Load			2.7	mA	
		HVD51, HVD52				8		
		HVD53		RE at 0 V, D at 0 V or V_{CC} , DE at 0 V, No load (Receiver enabled and driver disabled)				2.3
		HVD54, HVD55						2.9
		HVD53, HVD54, HVD55	RE at V_{CC} , D at V_{CC} , DE at 0 V, No load (Receiver disabled and driver disabled)			0.08	1	μ A
		HVD53	RE at 0 V, D at 0 V or V_{CC} , DE at V_{CC} , No load (Receiver enabled and driver enabled)				2.7	mA
		HVD54, HVD55					8	
		HVD53		RE at V_{CC} , D at 0 V or V_{CC} , DE at V_{CC} , No load (Receiver disabled and driver enabled)				
HVD54, HVD55						7.7		

(1) All typical values are at 25°C and with a 5-V supply.

7.7 Receiver Switching Characteristics

over recommended operating conditions unless otherwise noted

PARAMETER		TEST CONDITIONS	MIN	TYP ⁽¹⁾	MAX	UNIT		
t _{PLH}	Propagation delay time, low-to-high-level output	HVD50, HVD53		24	40	ns		
		HVD51, HVD52, HVD54, HVD55		43	55			
t _{PHL}	Propagation delay time, high-to-low-level output	HVD50, HVD53		26	35			
		HVD51, HVD52, HVD54, HVD55		47	60			
t _{sk(p)}	Pulse skew (t _{PHL} - t _{PLH})	HVD50, HVD53	V _{ID} = -1.5 V to 1.5 V, C _L = 15 pF, See Figure 8-9				5	
		HVD51, HVD54					7	
t _{sk(pp)} ⁽²⁾	Part-to-part skew	HVD50, HVD53			5			
		HVD51, HVD54			6			
		HVD52, HVD55			6			
t _r	Output signal rise time				2.3		4	
t _f	Output signal fall time				2.4		4	
t _{PHZ}	Output disable time from high level	DE at 3 V, C _L = 15 pF						17
t _{PZH1}	Output enable time to high level	See Figure 8-10						10
t _{PZH2}	Propagation delay time, standby-to-high-level output	DE at 0 V, C _L = 15 pF See Figure 8-10						3300
t _{PLZ}	Output disable time from low level	DE at 3 V, C _L = 15 pF						13
t _{PZL1}	Output enable time to low level	See Figure 8-11						10
t _{PZL2}	Propagation delay time, standby-to-low-level output	DE at 0 V, C _L = 15 pF See Figure 8-11					3300	

(1) All typical values are at 25°C and with a 5-V supply

(2) t_{sk(pp)} is the magnitude of the difference in propagation delay times between any specified terminals of two devices when both devices operate with the same supply voltages, at the same temperature, and have identical packages and test circuits.

7.8 Thermal Characteristics

over operating free-air temperature range unless otherwise noted⁽¹⁾

PARAMETER		TEST CONDITIONS		MIN	TYP	MAX	UNIT
θ_{JA}	Junction-to-ambient thermal resistance	Low-K board	HVD51		230.8		°C/W
			HVD53, HVD54, HVD55, HVD52, HVD50		-		
	Junction-to-ambient thermal resistance	High-K board	HVD51		135.1		
			HVD50, HVD52		116.7		
θ_{JB}	Junction-to-board thermal resistance	High-K board	HVD53, HVD54, HVD55		93.2		
			HVD51		44.4		
			HVD50, HVD52		63.4		
θ_{JC}	Junction-to-case thermal resistance	No board	HVD53, HVD54, HVD55		49.4		
			HVD51		43.5		
			HVD50, HVD52		56.3		
P_D	Device power dissipation	$R_L = 60\Omega$, $C_L = 50$ pF, Input to D a 50% duty cycle square wave at indicated signaling rate	HVD51, HVD52		47.5		mW
			HVD50 (25Mbps)		420		
			HVD51 (10Mbps)		404		
		$R_L = 60\Omega$, $C_L = 50$ pF, DE at V_{CC} \overline{RE} at 0 V, Input to D a 50% duty cycle square wave at indicated signaling rate	HVD52 (1Mbps)		383		
			HVD53 (25Mbps)		420		
			HVD54 (10Mbps)		404		
T_A	Ambient air temperature	Low-K board, No airflow	HVD55 (1Mbps)		383		
			HVD50	-40	55		
			HVD51, HVD52	-40	84		
		High-K board, No airflow	HVD53, HVD54, HVD55	-40	85		
			HVD50, HVD51, HVD52	-40	85		
T_{JSD}	Thermal shutdown junction temperature	HVD53, HVD54, HVD55	-40	85			
				165			

(1) See *Application Information* section for an explanation of these parameters.

7.9 Typical Characteristics

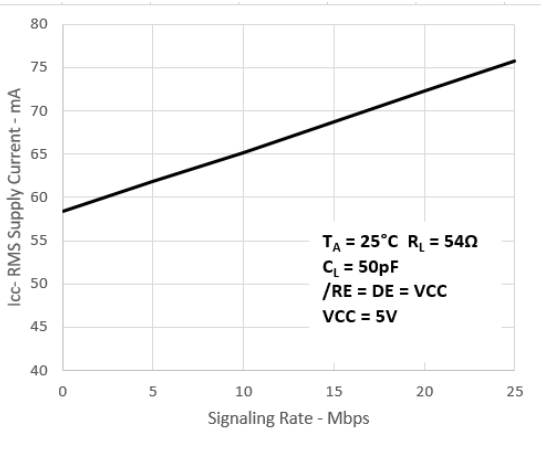

Figure 7-1. HVD50, HVD53 RMS Supply Current vs Signaling Rate

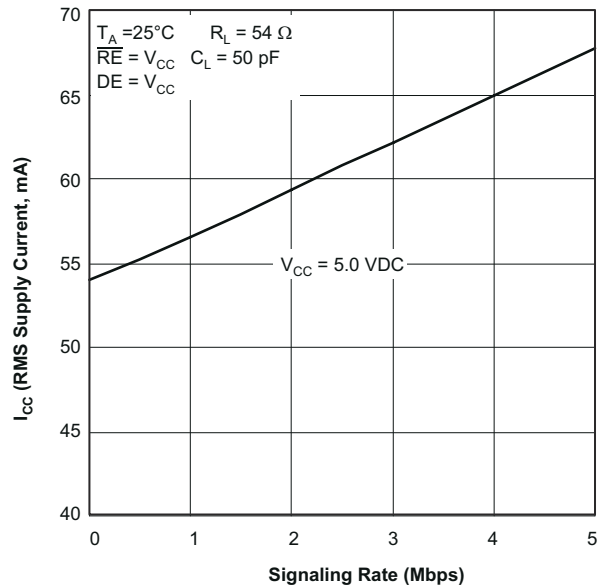

Figure 7-2. HVD51, HVD54 RMS Supply Current vs Signaling Rate

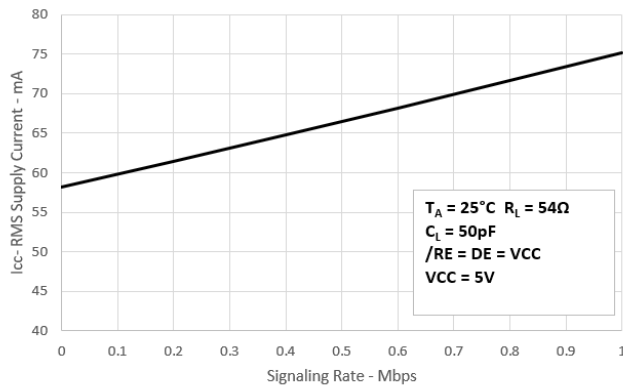

Figure 7-3. HVD52, HVD55 RMS Supply Current vs Signaling Rate

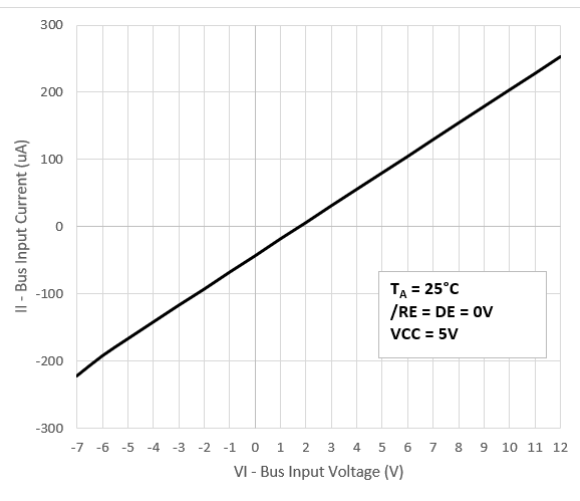

Figure 7-4. HVD50, HVD53 BUS Input Current vs Input Voltage

7.9 Typical Characteristics (continued)

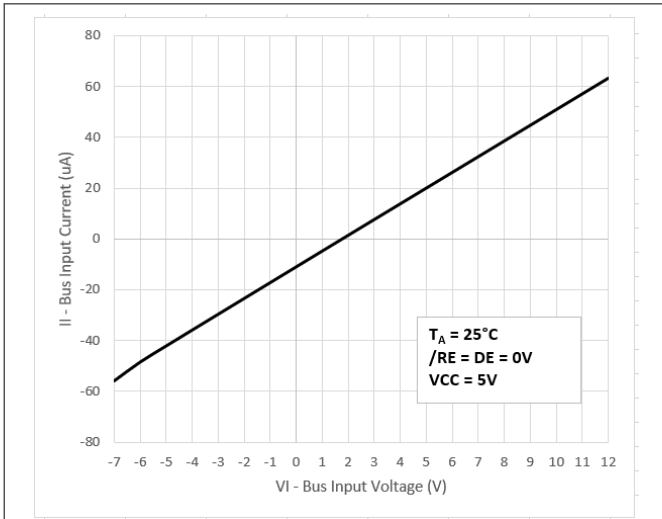

Figure 7-5. HVD51, HVD52, HVD54, HVD55 BUS Input Current vs Input Voltage

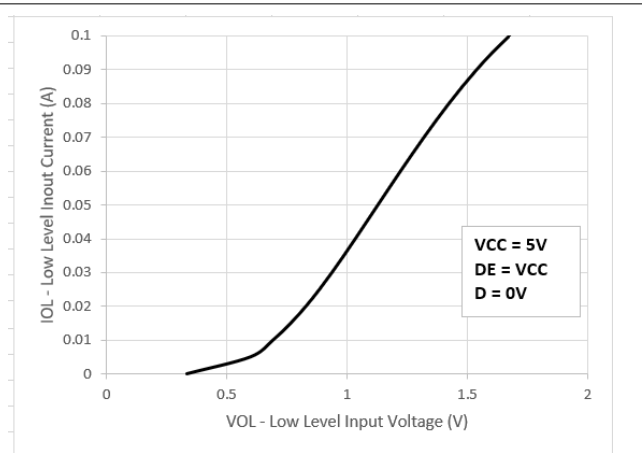

Figure 7-6. Driver LOW-Level Output Current vs Low-Level Output Voltage

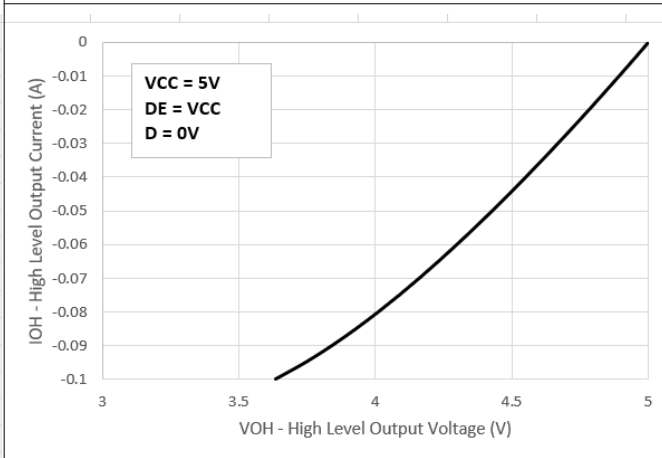

Figure 7-7. Driver High-Level Output Current vs High-Level Output Voltage

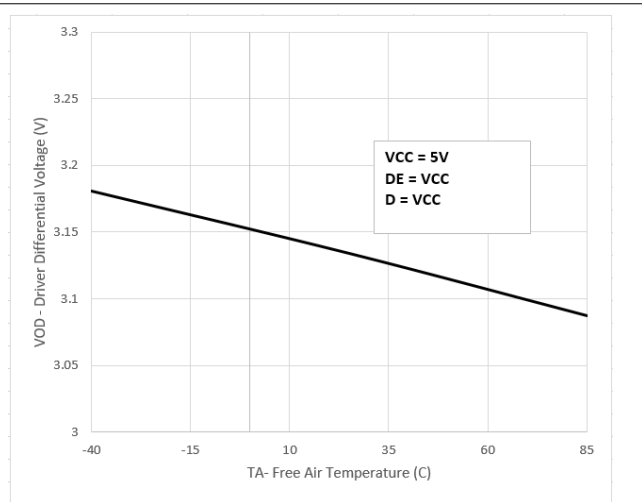

Figure 7-8. Driver Differential Output Voltage vs Free-Air Temperature

7.9 Typical Characteristics (continued)

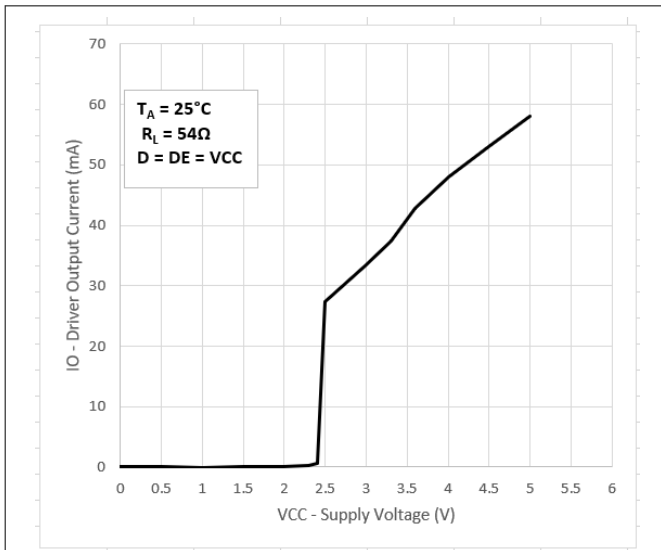

Figure 7-9. Driver Output Current vs Supply Voltage

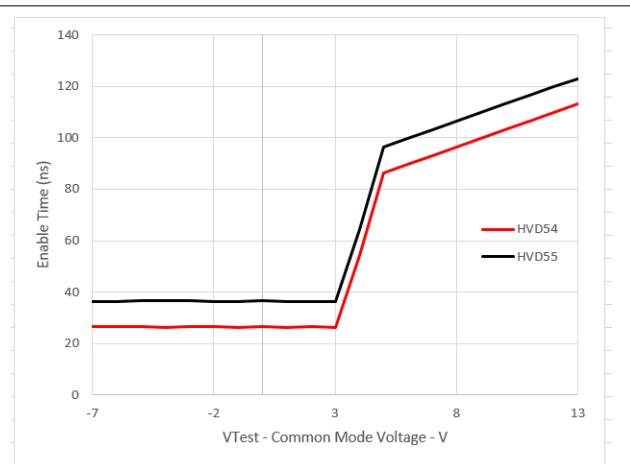

Figure 7-10. Enable Time vs Common-Mode Voltage
 (See Figure 7-12)

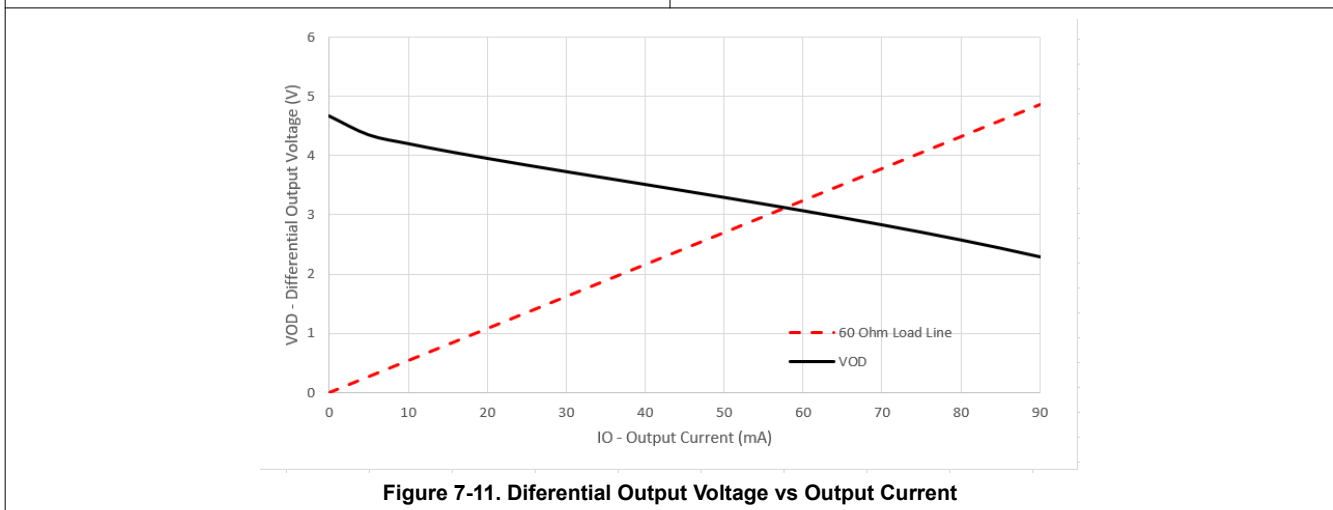
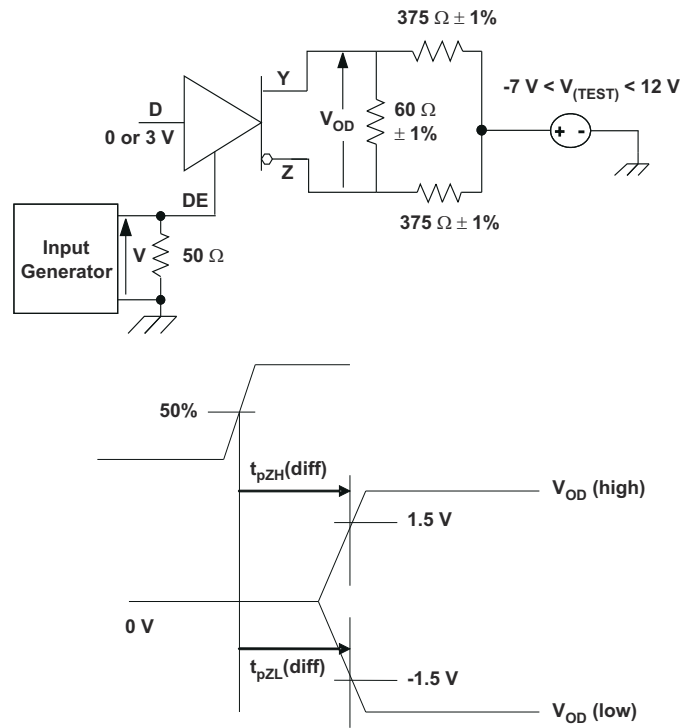

Figure 7-11. Differential Output Voltage vs Output Current

7.9 Typical Characteristics (continued)



1. The time $t_{pZL(x)}$ is the measure from DE to $V_{OD}(x)$. V_{OD} is valid when it is greater than 1.5 V.

Figure 7-12. Driver Enable Time From DE to V_{OD}

8 Parameter Measurement Information

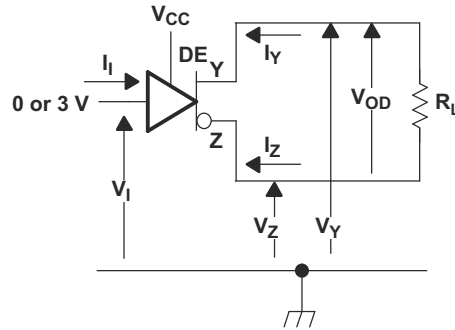

Figure 8-1. Driver V_{OD} Test Circuit: Voltage and Current Definitions

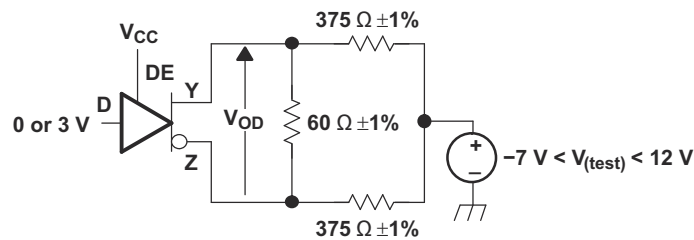

Figure 8-2. Driver V_{OD} With Common-Mode Loading Test Circuit

$V_{OD(RING)}$ is measured at four points on the output waveform, corresponding to overshoot and undershoot from the $V_{OD(H)}$ and $V_{OD(L)}$ steady state values.

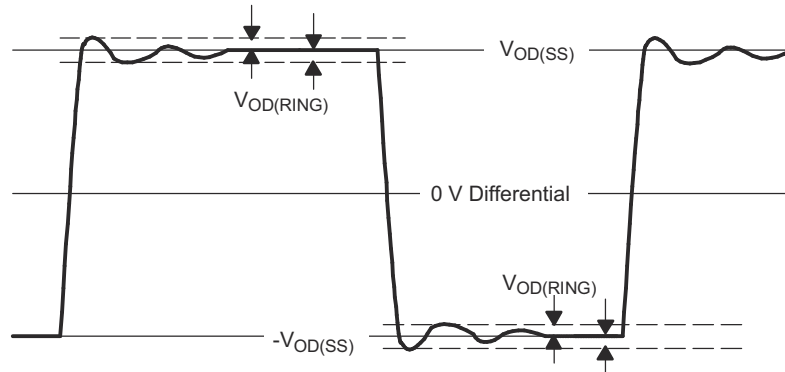
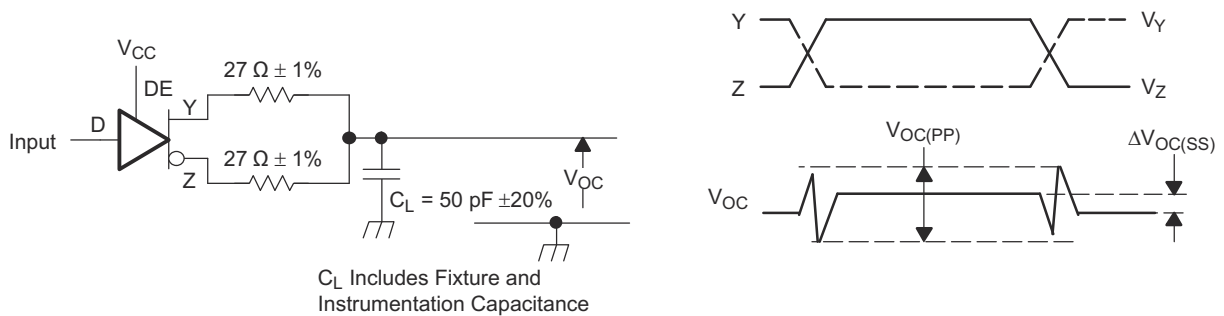

Figure 8-3. $V_{OD(RING)}$ Waveform and Definitions



C_L Includes Fixture and Instrumentation Capacitance
 Input: PRR = 500 kHz, 50% Duty Cycle, $t_r < 6ns$, $t_f < 6ns$, $Z_0 = 50 \Omega$

Figure 8-4. Test Circuit and Definitions for the Driver Common-Mode Output Voltage

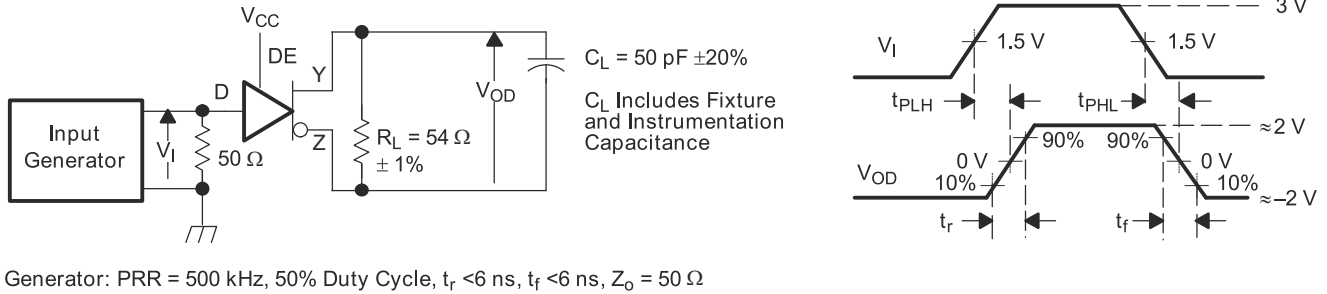

Figure 8-5. Driver Switching Test Circuit and Voltage Waveforms

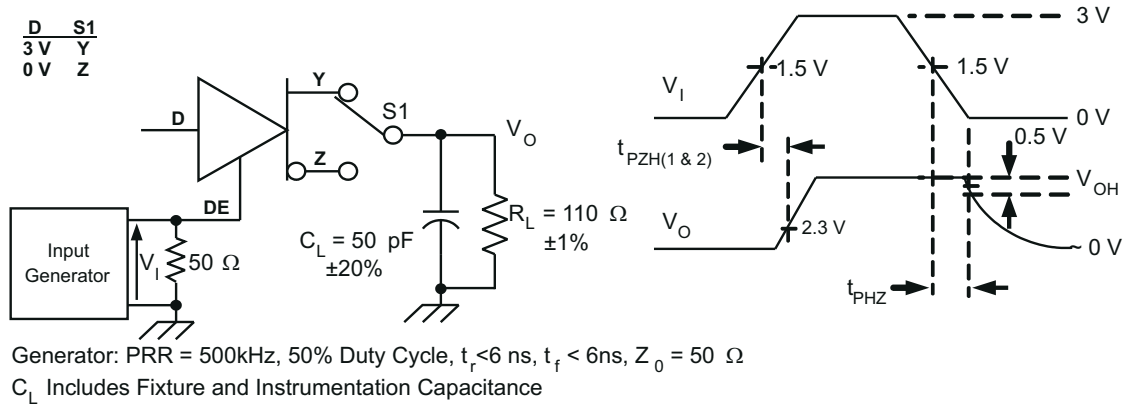

Figure 8-6. Driver High-Level Output Enable and Disable Time Test Circuit and Voltage Waveforms

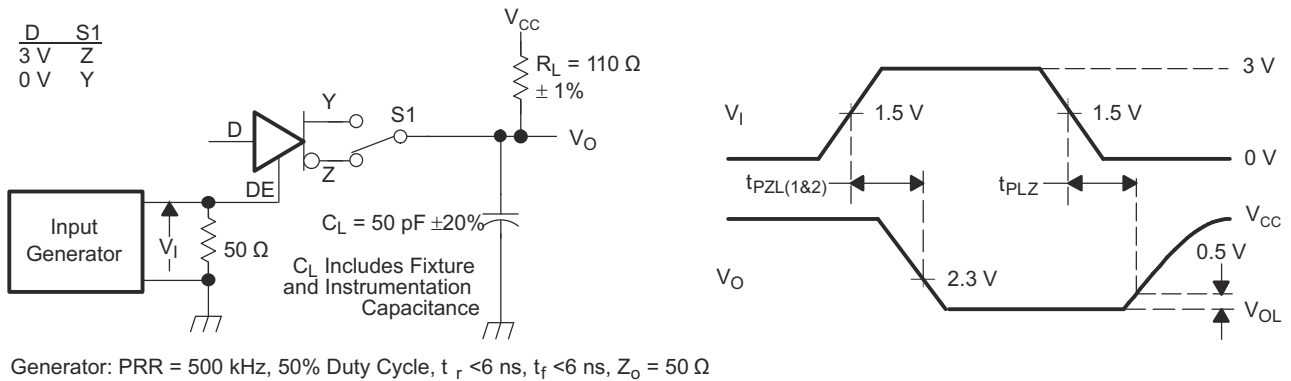

Figure 8-7. Driver Low-Level Output Enable and Disable Time Test Circuit and Voltage Waveforms

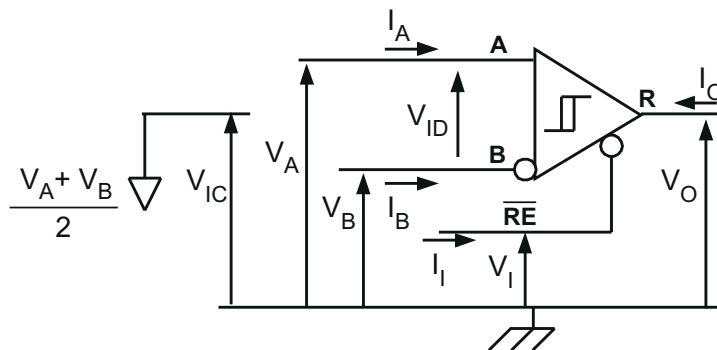

Figure 8-8. Receiver Voltage and Current Definitions

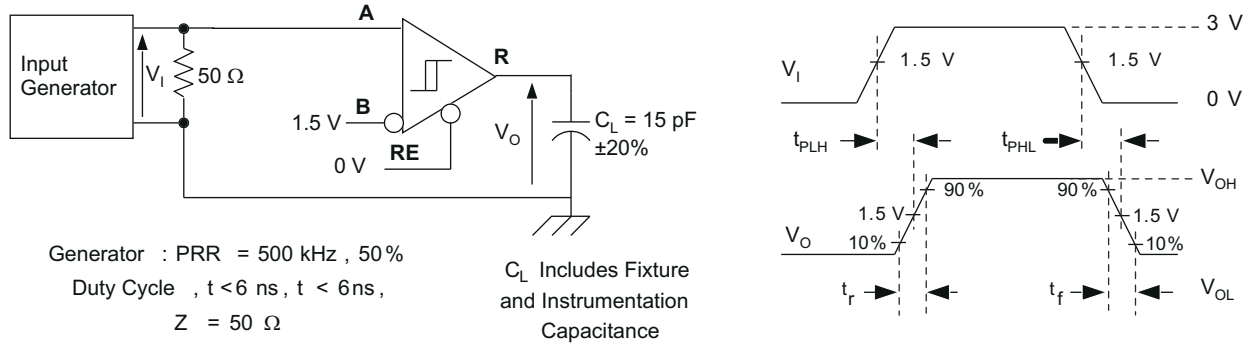

Figure 8-9. Receiver Switching Test Circuit and Voltage Waveforms

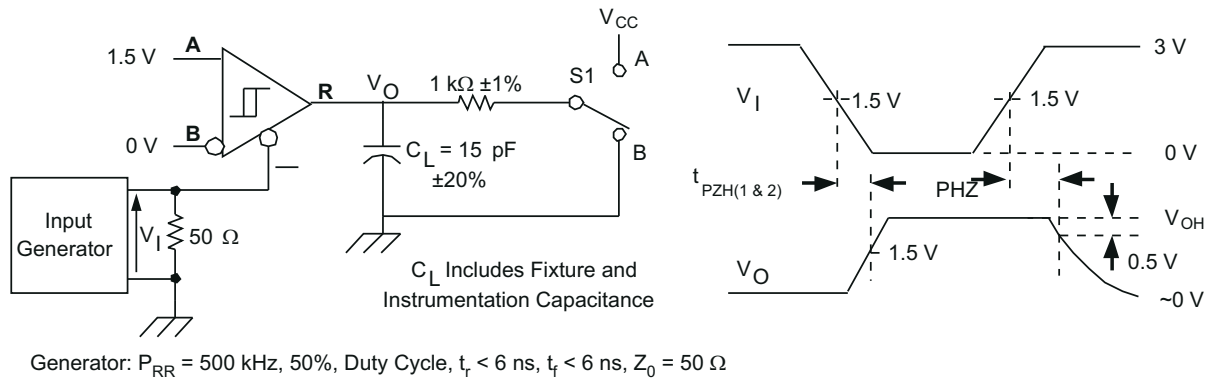

Figure 8-10. Receiver High-Level Enable and Disable Time Test Circuit and Voltage Waveforms

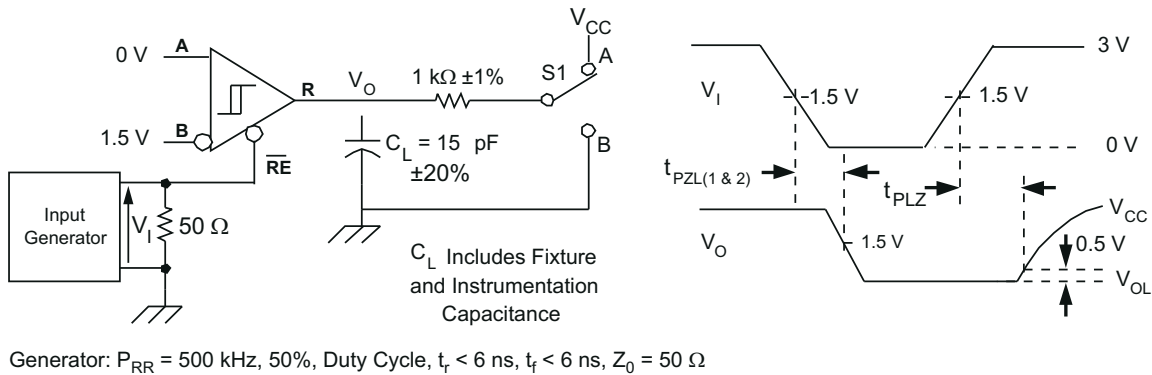

Figure 8-11. Receiver Low-Level Enable and Disable Time Test Circuit and Voltage Waveforms

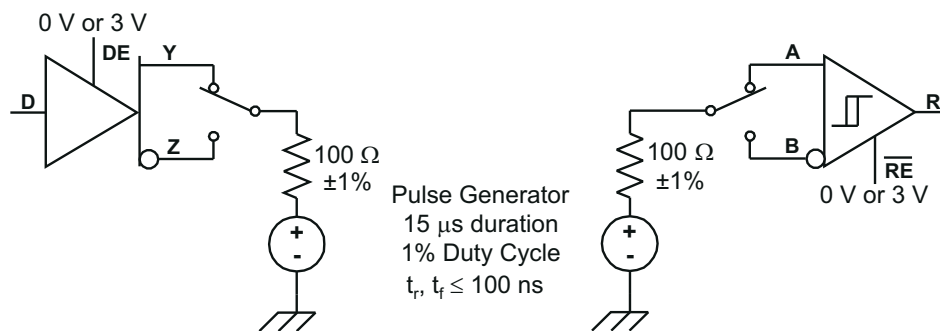

Figure 8-12. Test Circuit, Transient Overvoltage Test

9 Device Information

9.1 LI-Power Standby Mode

When both the driver and receiver are disabled (\overline{RE} low and \overline{DE} high) the device is in standby mode. If the enable inputs are in this state for less than 60 ns, the device does not enter standby mode. This guards against inadvertently entering standby mode during driver/receiver enabling. Only when the enable inputs are held in this state for 300 ns or more, the device is assured to be in standby mode. In this low-power standby mode, most internal circuitry is powered down, and the supply current is typically less than 1 nA. When either the driver or the receiver is re-enabled, the internal circuitry becomes active.

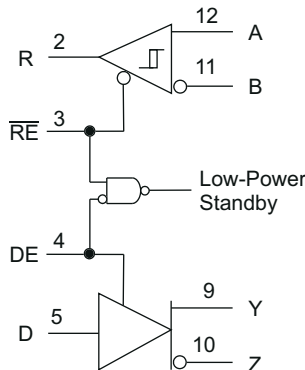

Figure 9-1. Low-Power Standby Logic Diagram

If only the driver is re-enabled (\overline{DE} transitions to high) the driver outputs are driven according to the D input after the enable times given by t_{PZH2} and t_{PZL2} in the driver switching characteristics. If the D input is open when the driver is enabled, the driver outputs default to A high and B low, in accordance with the driver failsafe feature.

If only the receiver is re-enabled (\overline{RE} transitions to low) the receiver output is driven according to the state of the bus inputs (A and B) after the enable times given by t_{PZH2} and t_{PZL2} in the receiver switching characteristics. If there is no valid state on the bus the receiver responds as described in the failsafe operation section.

If both the receiver and driver are re-enabled simultaneously, the receiver output is driven according to the state of the bus inputs (A and B) and the driver output is driven according to the D input. Note that the state of the active driver affects the inputs to the receiver. Therefore, the receiver outputs are valid as soon as the driver outputs are valid.

9.2 Function Tables

**Table 9-1. SN65HVD53, SN65HVD54, SN65HVD55
DRIVER**

INPUTS		OUTPUTS	
D	DE	Y	Z
H	H	H	L
L	H	L	H
X	L or open	Z	Z
Open	H	L	H

**Table 9-2. SN65HVD53, SN65HVD54, SN65HVD55
RECEIVER**

DIFFERENTIAL INPUTS $V_{ID} = V_{(A)} - V_{(B)}$	ENABLE RE	OUTPUT R
$V_{ID} \leq -0.2 \text{ V}$	L	L
$-0.2 \text{ V} < V_{ID} < -0.02 \text{ V}$	L	?
$-0.02 \text{ V} \leq V_{ID}$	L	H
X	H or open	Z
Open Circuit	L	H
Idle circuit	L	H
Short Circuit, $V_{(A)} = V_{(B)}$	L	H

**Table 9-3. SN65HVD50, SN65HVD51, SN65HVD52
DRIVER**

INPUT D	OUTPUTS	
	Y	Z
H	H	L
L	L	H
Open	L	H

**Table 9-4. SN65HVD50, SN65HVD51, SN65HVD52
RECEIVER**

DIFFERENTIAL INPUTS $V_{ID} = V_{(A)} - V_{(B)}$	OUTPUT R
$V_{ID} \leq -0.2 \text{ V}$	L
$-0.2 \text{ V} < V_{ID} < -0.02 \text{ V}$?
$-0.02 \text{ V} \leq V_{ID}$	H
Open Circuit	H
Idle circuit	H
Short Circuit, $V_{(A)} = V_{(B)}$	H

9.3 Equivalent Input and Output Schematic Diagrams

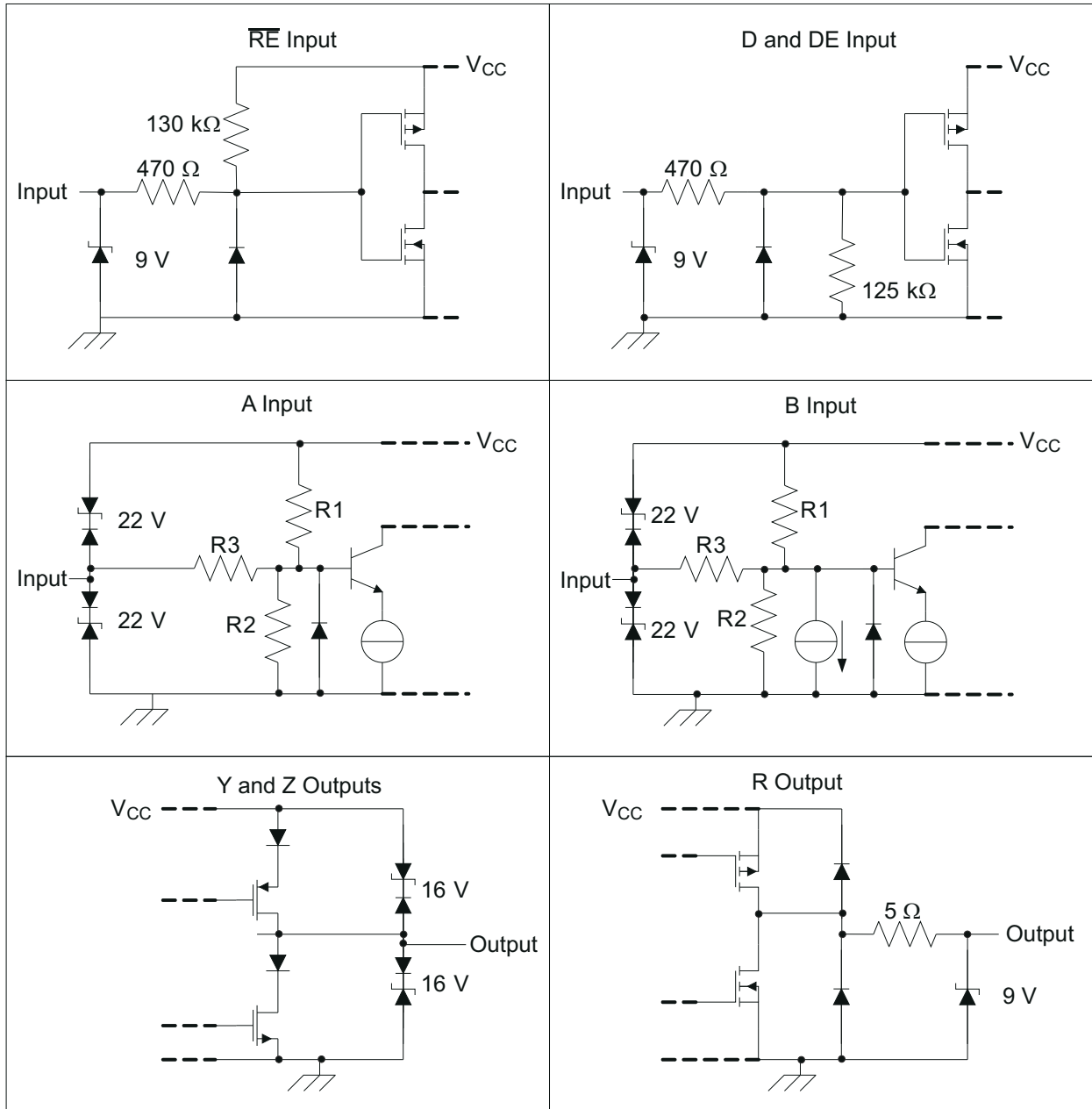

	R1/R2	R3
SN65HVD50, SN65HVD53	9 kΩ	45 kΩ
SN65HVD51, SN65HVD52, SN65HVD54, SN65HVD55	36 kΩ	180 kΩ

10 Application and Implementation

Note

Information in the following applications sections is not part of the TI component specification, and TI does not warrant its accuracy or completeness. TI's customers are responsible for determining suitability of components for their purposes, as well as validating and testing their design implementation to confirm system functionality.

10.1 Thermal Characteristics of IC Packages

θ_{JA} (Junction-to-Ambient Thermal Resistance) is defined as the difference in junction temperature to ambient temperature divided by the operating power.

θ_{JA} is not a constant and is a strong function of:

- the PCB design (50% variation)
- altitude (20% variation)
- device power (5% variation)

θ_{JA} can be used to compare the thermal performance of packages if the specific test conditions are defined and used. Standardized testing includes specification of PCB construction, test chamber volume, sensor locations, and the thermal characteristics of holding fixtures. θ_{JA} is often misused when it is used to calculate junction temperatures for other installations.

TI uses two test PCBs as defined by JEDEC specifications. The low-k board gives *average* in-use condition thermal performance, and it consists of a single copper trace layer 25 mm long and 2-oz thick. The high-k board gives best *case* in-use condition, and it consists of two 1-oz buried power planes with a single copper trace layer 25 mm long and 2-oz thick. A 4% to 50% difference in θ_{JA} can be measured between these two test cards

θ_{JC} (Junction-to-Case Thermal Resistance) is defined as difference in junction temperature to case divided by the operating power. It is measured by putting the mounted package up against a copper block cold plate to force heat to flow from die, through the mold compound into the copper block.

θ_{JC} is a useful thermal characteristic when a heatsink applied to package. It is *not* a useful characteristic to predict junction temperature because it provides pessimistic numbers if the case temperature is measured in a nonstandard system and junction temperatures are backed out. It can be used with θ_{JB} in 1-dimensional thermal simulation of a package system.

θ_{JB} (Junction-to-Board Thermal Resistance) is defined as the difference in the junction temperature and the PCB temperature at the center of the package (closest to the die) when the PCB is clamped in a cold-plate structure. θ_{JB} is only defined for the high-k test card.

θ_{JB} provides an overall thermal resistance between the die and the PCB. It includes a bit of the PCB thermal resistance (especially for BGA's with thermal balls) and can be used for simple 1-dimensional network analysis of package system, see [Figure 10-1](#).

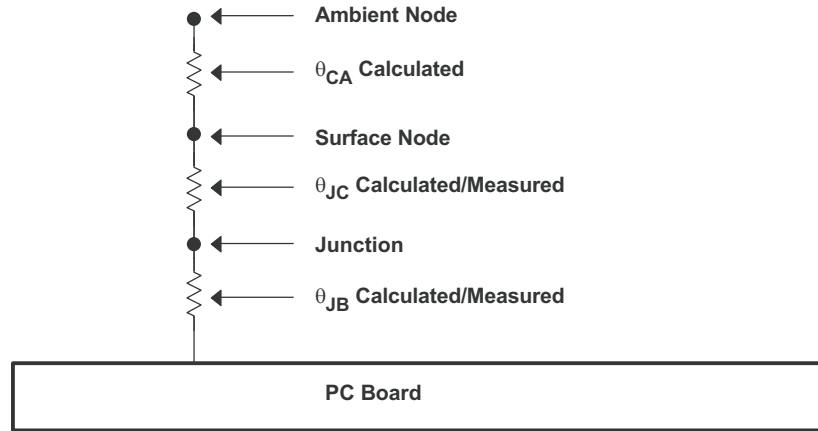

Figure 10-1. Thermal Resistance

11 Device and Documentation Support

11.1 Receiving Notification of Documentation Updates

To receive notification of documentation updates, navigate to the device product folder on ti.com. Click on *Subscribe to updates* to register and receive a weekly digest of any product information that has changed. For change details, review the revision history included in any revised document.

11.2 Support Resources

TI E2E™ [support forums](#) are an engineer's go-to source for fast, verified answers and design help — straight from the experts. Search existing answers or ask your own question to get the quick design help you need.

Linked content is provided "AS IS" by the respective contributors. They do not constitute TI specifications and do not necessarily reflect TI's views; see TI's [Terms of Use](#).

11.3 Trademarks

TI E2E™ is a trademark of Texas Instruments.
All trademarks are the property of their respective owners.

11.4 Electrostatic Discharge Caution



This integrated circuit can be damaged by ESD. Texas Instruments recommends that all integrated circuits be handled with appropriate precautions. Failure to observe proper handling and installation procedures can cause damage.

ESD damage can range from subtle performance degradation to complete device failure. Precision integrated circuits may be more susceptible to damage because very small parametric changes could cause the device not to meet its published specifications.

11.5 Glossary

[TI Glossary](#) This glossary lists and explains terms, acronyms, and definitions.

12 Mechanical, Packaging, and Orderable Information

The following pages include mechanical, packaging, and orderable information. This information is the most current data available for the designated devices. This data is subject to change without notice and revision of this document. For browser-based versions of this data sheet, refer to the left-hand navigation.

PACKAGING INFORMATION

Orderable Device	Status (1)	Package Type	Package Drawing	Pins	Package Qty	Eco Plan (2)	Lead finish/ Ball material (6)	MSL Peak Temp (3)	Op Temp (°C)	Device Marking (4/5)	Samples
SN65HVD50DR	ACTIVE	SOIC	D	8	2500	RoHS & Green	NIPDAU	Level-1-260C-UNLIM	-40 to 85	VP50	Samples
SN65HVD52DR	ACTIVE	SOIC	D	8	2500	RoHS & Green	NIPDAU	Level-1-260C-UNLIM	-40 to 85	VP52	Samples
SN65HVD53DR	ACTIVE	SOIC	D	14	2500	RoHS & Green	NIPDAU	Level-1-260C-UNLIM	-40 to 85	65HVD53	Samples
SN65HVD54DR	ACTIVE	SOIC	D	14	2500	RoHS & Green	NIPDAU	Level-1-260C-UNLIM	-40 to 85	65HVD54	Samples
SN65HVD55DR	ACTIVE	SOIC	D	14	2500	RoHS & Green	NIPDAU	Level-1-260C-UNLIM	-40 to 85	65HVD55	Samples

(1) The marketing status values are defined as follows:

ACTIVE: Product device recommended for new designs.

LIFEBUY: TI has announced that the device will be discontinued, and a lifetime-buy period is in effect.

NRND: Not recommended for new designs. Device is in production to support existing customers, but TI does not recommend using this part in a new design.

PREVIEW: Device has been announced but is not in production. Samples may or may not be available.

OBSOLETE: TI has discontinued the production of the device.

(2) **RoHS:** TI defines "RoHS" to mean semiconductor products that are compliant with the current EU RoHS requirements for all 10 RoHS substances, including the requirement that RoHS substance do not exceed 0.1% by weight in homogeneous materials. Where designed to be soldered at high temperatures, "RoHS" products are suitable for use in specified lead-free processes. TI may reference these types of products as "Pb-Free".

RoHS Exempt: TI defines "RoHS Exempt" to mean products that contain lead but are compliant with EU RoHS pursuant to a specific EU RoHS exemption.

Green: TI defines "Green" to mean the content of Chlorine (Cl) and Bromine (Br) based flame retardants meet JS709B low halogen requirements of <=1000ppm threshold. Antimony trioxide based flame retardants must also meet the <=1000ppm threshold requirement.

(3) MSL, Peak Temp. - The Moisture Sensitivity Level rating according to the JEDEC industry standard classifications, and peak solder temperature.

(4) There may be additional marking, which relates to the logo, the lot trace code information, or the environmental category on the device.

(5) Multiple Device Markings will be inside parentheses. Only one Device Marking contained in parentheses and separated by a "~" will appear on a device. If a line is indented then it is a continuation of the previous line and the two combined represent the entire Device Marking for that device.

(6) Lead finish/Ball material - Orderable Devices may have multiple material finish options. Finish options are separated by a vertical ruled line. Lead finish/Ball material values may wrap to two lines if the finish value exceeds the maximum column width.

Important Information and Disclaimer: The information provided on this page represents TI's knowledge and belief as of the date that it is provided. TI bases its knowledge and belief on information provided by third parties, and makes no representation or warranty as to the accuracy of such information. Efforts are underway to better integrate information from third parties. TI has taken and continues to take reasonable steps to provide representative and accurate information but may not have conducted destructive testing or chemical analysis on incoming materials and chemicals. TI and TI suppliers consider certain information to be proprietary, and thus CAS numbers and other limited information may not be available for release.

In no event shall TI's liability arising out of such information exceed the total purchase price of the TI part(s) at issue in this document sold by TI to Customer on an annual basis.

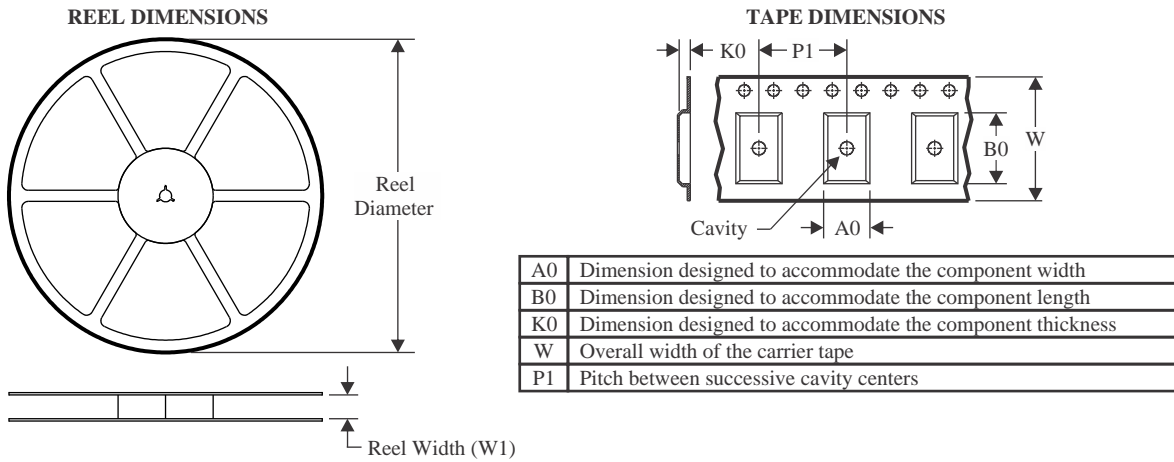
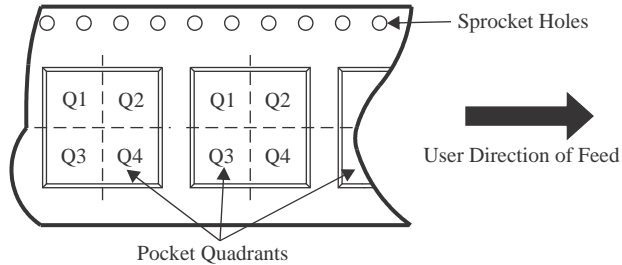
TAPE AND REEL INFORMATION

QUADRANT ASSIGNMENTS FOR PIN 1 ORIENTATION IN TAPE

*All dimensions are nominal

Device	Package Type	Package Drawing	Pins	SPQ	Reel Diameter (mm)	Reel Width W1 (mm)	A0 (mm)	B0 (mm)	K0 (mm)	P1 (mm)	W (mm)	Pin1 Quadrant
SN65HVD50DR	SOIC	D	8	2500	330.0	12.4	6.4	5.2	2.1	8.0	12.0	Q1
SN65HVD50DR	SOIC	D	8	2500	330.0	12.4	6.4	5.2	2.1	8.0	12.0	Q1
SN65HVD52DR	SOIC	D	8	2500	330.0	12.4	6.4	5.2	2.1	8.0	12.0	Q1
SN65HVD52DR	SOIC	D	8	2500	330.0	12.4	6.4	5.2	2.1	8.0	12.0	Q1
SN65HVD53DR	SOIC	D	14	2500	330.0	16.4	6.5	9.0	2.1	8.0	16.0	Q1
SN65HVD54DR	SOIC	D	14	2500	330.0	16.4	6.5	9.0	2.1	8.0	16.0	Q1
SN65HVD55DR	SOIC	D	14	2500	330.0	16.4	6.5	9.0	2.1	8.0	16.0	Q1

TAPE AND REEL BOX DIMENSIONS

*All dimensions are nominal

Device	Package Type	Package Drawing	Pins	SPQ	Length (mm)	Width (mm)	Height (mm)
SN65HVD50DR	SOIC	D	8	2500	356.0	356.0	35.0
SN65HVD50DR	SOIC	D	8	2500	356.0	356.0	35.0
SN65HVD52DR	SOIC	D	8	2500	356.0	356.0	35.0
SN65HVD52DR	SOIC	D	8	2500	356.0	356.0	35.0
SN65HVD53DR	SOIC	D	14	2500	356.0	356.0	35.0
SN65HVD54DR	SOIC	D	14	2500	350.0	350.0	43.0
SN65HVD55DR	SOIC	D	14	2500	356.0	356.0	35.0

D (R-PDSO-G14)

PLASTIC SMALL OUTLINE

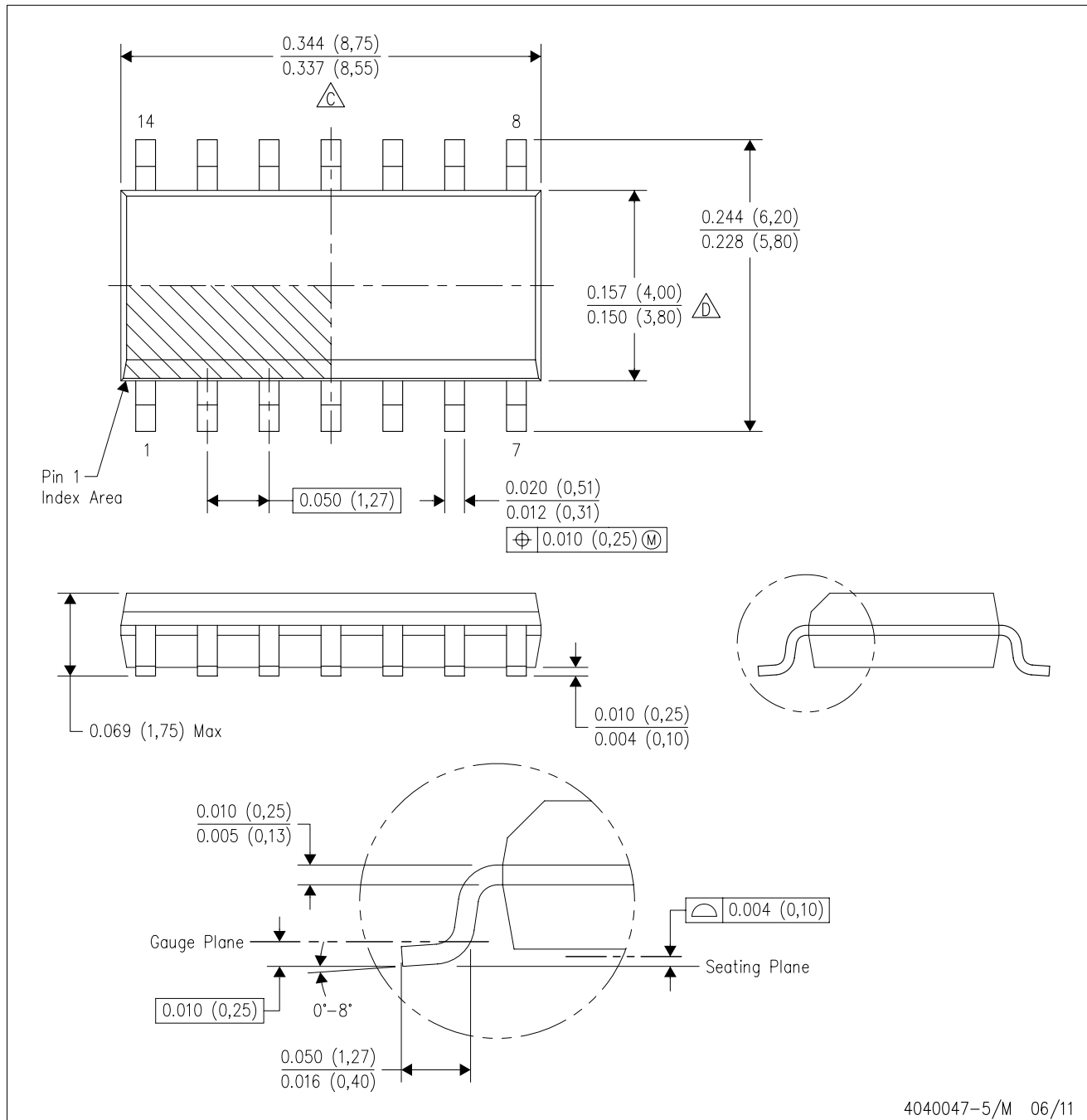

- NOTES:
- A. All linear dimensions are in inches (millimeters).
 - B. This drawing is subject to change without notice.
 - Body length does not include mold flash, protrusions, or gate burrs. Mold flash, protrusions, or gate burrs shall not exceed 0.006 (0,15) each side.
 - Body width does not include interlead flash. Interlead flash shall not exceed 0.017 (0,43) each side.
 - E. Reference JEDEC MS-012 variation AB.

D (R-PDSO-G14)

PLASTIC SMALL OUTLINE



- NOTES:
- All linear dimensions are in millimeters.
 - This drawing is subject to change without notice.
 - Publication IPC-7351 is recommended for alternate designs.
 - Laser cutting apertures with trapezoidal walls and also rounding corners will offer better paste release. Customers should contact their board assembly site for stencil design recommendations. Refer to IPC-7525 for other stencil recommendations.
 - Customers should contact their board fabrication site for solder mask tolerances between and around signal pads.



D0008A

PACKAGE OUTLINE

SOIC - 1.75 mm max height

SMALL OUTLINE INTEGRATED CIRCUIT



4214825/C 02/2019

NOTES:

1. Linear dimensions are in inches [millimeters]. Dimensions in parenthesis are for reference only. Controlling dimensions are in inches. Dimensioning and tolerancing per ASME Y14.5M.
2. This drawing is subject to change without notice.
3. This dimension does not include mold flash, protrusions, or gate burrs. Mold flash, protrusions, or gate burrs shall not exceed $.006$ [0.15] per side.
4. This dimension does not include interlead flash.
5. Reference JEDEC registration MS-012, variation AA.

EXAMPLE BOARD LAYOUT

D0008A

SOIC - 1.75 mm max height

SMALL OUTLINE INTEGRATED CIRCUIT



LAND PATTERN EXAMPLE
 EXPOSED METAL SHOWN
 SCALE:8X



SOLDER MASK DETAILS

4214825/C 02/2019

NOTES: (continued)

- 6. Publication IPC-7351 may have alternate designs.
- 7. Solder mask tolerances between and around signal pads can vary based on board fabrication site.

EXAMPLE STENCIL DESIGN

D0008A

SOIC - 1.75 mm max height

SMALL OUTLINE INTEGRATED CIRCUIT



SOLDER PASTE EXAMPLE
BASED ON .005 INCH [0.125 MM] THICK STENCIL
SCALE:8X

4214825/C 02/2019

NOTES: (continued)

8. Laser cutting apertures with trapezoidal walls and rounded corners may offer better paste release. IPC-7525 may have alternate design recommendations.
9. Board assembly site may have different recommendations for stencil design.

IMPORTANT NOTICE AND DISCLAIMER

TI PROVIDES TECHNICAL AND RELIABILITY DATA (INCLUDING DATA SHEETS), DESIGN RESOURCES (INCLUDING REFERENCE DESIGNS), APPLICATION OR OTHER DESIGN ADVICE, WEB TOOLS, SAFETY INFORMATION, AND OTHER RESOURCES "AS IS" AND WITH ALL FAULTS, AND DISCLAIMS ALL WARRANTIES, EXPRESS AND IMPLIED, INCLUDING WITHOUT LIMITATION ANY IMPLIED WARRANTIES OF MERCHANTABILITY, FITNESS FOR A PARTICULAR PURPOSE OR NON-INFRINGEMENT OF THIRD PARTY INTELLECTUAL PROPERTY RIGHTS.

These resources are intended for skilled developers designing with TI products. You are solely responsible for (1) selecting the appropriate TI products for your application, (2) designing, validating and testing your application, and (3) ensuring your application meets applicable standards, and any other safety, security, regulatory or other requirements.

These resources are subject to change without notice. TI grants you permission to use these resources only for development of an application that uses the TI products described in the resource. Other reproduction and display of these resources is prohibited. No license is granted to any other TI intellectual property right or to any third party intellectual property right. TI disclaims responsibility for, and you will fully indemnify TI and its representatives against, any claims, damages, costs, losses, and liabilities arising out of your use of these resources.

TI's products are provided subject to [TI's Terms of Sale](#) or other applicable terms available either on [ti.com](https://www.ti.com) or provided in conjunction with such TI products. TI's provision of these resources does not expand or otherwise alter TI's applicable warranties or warranty disclaimers for TI products.

TI objects to and rejects any additional or different terms you may have proposed.

Mailing Address: Texas Instruments, Post Office Box 655303, Dallas, Texas 75265
Copyright © 2024, Texas Instruments Incorporated

Looking for pricing, stock, or lifecycle information?

Click below to explore more details on WIN SOURCE:

 [View SN65HVD51DR on WIN SOURCE](#)

 [Texas Instruments](#) Information

Optimize Your Supply Chain with WIN SOURCE Solutions

-  Global Sourcing Solution
-  Obsolete Management
-  Cost Control Management
-  Shortage Management
-  Alternative Solution
-  Excess Inventory Management